

PS2 - PLAYSTATION - DREAMCAST - PC - N64 - X-BOX - GAME BOY

PLUS ONLINE GAMES AND NET NEWS!

# HYPER



## OVER 250 GAMES PREVIEWED!

Our huge 2000-2001 rundown... All the games - all the systems!

METAL GEAR SOLID 2 • WIPEOUT FUSION  
RETURN TO CASTLE WOLFENSTEIN • ONI  
TRIBES 2 • POD 2 • SONIC ADVENTURE 2  
DINOSAUR PLANET • FINAL FANTASY IX  
TONY HAWK 2 • LEGEND OF DRAGON  
BLACK AND WHITE • POWERSTONE 2  
TUROK 3 • MSR • ZELDA: MAJORA'S MASK  
MUNCH'S ODDYSEE • AND LOTS MORE!



PLUS!

SHOGUN

TOMBI 2

DARK REIGN 2

COLIN McRAE RALLY 2

MOTOCROSS MADNESS 2

RESIDENT EVIL: CODE VERONICA

REVIEWED



## REVIEWED! PERFECT DARK

Perfect game!

## THE FUTURE OF GAMING

See what the top games developers think of the superconsoles!

next gaming

82



9 771320 745001

AUGUST 2000

Hyper 82 up until the 30/6/2000 \$6.50  
After and inc 1/7/2000 \$7.15  
NZ \$9.50 (inc GST)

VISIT US ONLINE AT WWW.HYPERACTIVE.COM.AU



Realistic 3-D environments, day and night missions and true line-of-sight bring the battlefield to life.

Dominate the Internet with intense 16-player action, including Capture the Flag and cooperative play.



ASSAULT THE HILL BY COMMANDEERING A TANK BRIGADE.

GROUND VIEW

Battle as the elite IDA or as the ragtag revolutionary Sprawlers in 20 challenging single-player missions.

Utilize powerful, strategic controls, including a squad and building manager, smart targeting and formations.

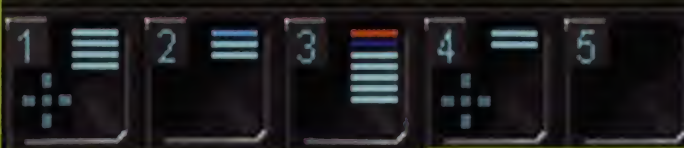

Activision is a registered trademark and All rights reserved. All other trademarks



# REIGN FROM ABOVE. REIGN IN THE TRENCHES.



TAKE DEFENSIVE  
ACTION TO RESCUE  
YOUR TROOPS.



GROUND VIEW

For the first time ever in a Real-Time Strategy game, run your war from the traditional RTS view or zoom into the heat of battle using multiple camera perspectives. You're down in the trenches seeing the direct effect of your decisions. If a platoon eats it, you'll be there to count the bodies. This is war, up close and personal. Welcome to the battlefield of the future. Welcome to *Dark Reign™2*.

"*Dark Reign™2* looks set to take a commanding lead among the next wave of real-time strategy titles."

GAMESPOT

# DARK REIGN 2

THE BATTLEFIELD OF THE FUTURE



# contents

06..... NEWS

12..... **FEATURE - E3 BLOWOUT!**  
THE GAMES OF 2000-2001.  
WE SPEW OUT MORE  
SCREENSHOTS OF UPCOMING  
GAMES THAN YOU CAN FIT IN  
YOUR BRAIN.

32..... **SUBSCRIPTIONS**  
SUBSCRIBE TO HYPER AND  
WE'LL GIVE YOU FREE STUFF!

34..... **WAREZ**  
WE CHECK OUT SOME  
UPCOMING ADD-ONS FOR THE  
DREAMCAST. THEY ROCK!

36..... **FEATURE - THE FUTURE OF  
GAMING**  
WE SPEAK ONE-ON-ONE WITH  
SOME OF THE WORLD'S MOST  
IMPORTANT GAMES  
DEVELOPERS IN PART 1 OF  
OUR PEEK INTO THE FUTURE  
OF GAMING.

44..... **NET TRAWLIN'**  
COME AND VENTURE FORTH  
INTO THE RUINS OF KUNARK,  
THE LATEST FOR EVERQUEST.  
PLUS THE LATEST NET NEWS  
AND TASTY URLS.

48..... **COMPS**  
WIN GAMES!!

## reviews

NINTENDO 64

58..... PERFECT DARK  
70..... EXCITEBIKE 64

PLAYSTATION

62..... COLIN MCRAE RALLY 2  
74..... TOMBI! 2  
77..... N-GEN RACING  
78..... DISCWORLD NOIR

78..... GEKIDO: URBAN FIGHTERS  
78..... STAR OCEAN: SECOND STORY

## DREAMCAST

66..... RESIDENT EVIL: CODE  
VERONICA  
75..... SWORD OF THE BERSERK  
76..... TIMESTALKERS

## PC

64..... DARK REIGN 2  
68..... MOTOCROSS MADNESS 2  
72..... SHOGUN: TOTAL WAR

## GAME BOY

80..... DRIVER  
80..... LE MANS 24 HOURS  
80..... SPEEDY GONZALES: AZTEC  
ADVENTURE  
80..... 1942

82..... **REVERSE ENGINEERING**  
THE GLORY DAYS OF THE NES,  
AND THE WONDERFUL METAL  
GEAR!

84..... **VERSUS MODE**  
VIRTUAL REALITY VERSUS  
ACTUAL REALITY. WHICH IS  
BETTER?

86..... ANIME

87..... ARCADE MODE

88..... CHEAT MODE

92..... **INCOMING MAIL**  
TAKE A TRIP THROUGH ELIOT'S E3  
DIARY AND READ UP ON WHAT OTHER  
READERS THINK OF THE STATE OF  
GAMING. PLUS OTHER WEIRD STUFF.

97..... HYPERMART

98..... COMING NEXT ISSUE!

## 12..... SNEAK A PEEK AT OVER 200 GAMES!

SINCE E3, THE HYPER OFFICE HAS BEEN  
OVERFLOWING WITH NEW GAMES. WE'VE PUT  
TOGETHER A GALLERY OF ALL THE GAMES TO  
LOOK FORWARD TO OVER THE NEXT YEAR!





## 36.... FEATURE – THE FUTURE OF GAMING

HYPHER CHATS TO THE BIG NAMES IN THE GAMES INDUSTRY TO FIND OUT THEIR OPINIONS ON THE SUPER CONSOLES, THE STATE OF PC GAMING AND WHAT THE FUTURE HOLDS!



## 58.... GAME OF THE MONTH – PERFECT DARK ON NINTENDO 64

RARE PUSH THE NINTENDO 64 TO BREAKING POINT WITH THE BEST GAME ON THE SYSTEM EVER.



## editorial

Perfect. It describes the gameplay, the options, the visuals - oh, and Joanna. Perfect Dark on the Nintendo 64 was just what we needed this month to kick back and enjoy after an exhausting trip to Los Angeles. Check out our 20 pages of upcoming games! Besides the arrival of Perfect Dark, some other long-awaited games arrived at the office this month... Colin McRae Rally 2 (the actual finished game, not some dodgy preview code which another magazine reviewed), Dark Reign 2 for the PC strategy freaks and Code Veronica for Dreamcast lovers (which includes me). In fact, the Dreamcast stole the show at E3 in Los Angeles. Lots of great GAMEPLAY to look forward to... now if I could only stop Cam playing Ecco...

## issue

# 82

AUGUST 2000

Editor: Eliot Fish

Art Director: David Harvey

Deputy Editor: Cam Shea

Publisher: Jim Flynn

### ADVERTISING

Advertising Manager: Gill Oliver

National Sales Director: Victoria Meades

Advertising Production Co-ordinator: Dylan Fryer

Ph: 02 9699 0333

Fax: 02 9310 2012

Production Manager: Melissa Doyle

Circulation Director: Karen Day

Finance Director: Theo Fatseas

Managing Director: Phillip Keir

### Subscriptions Enquiries

ph: 1300 3611 46

Fax: 02 9699 0334

email: subs@next.com.au

### CONTRIBUTORS:

Dan Toose, DMC, Tim Levy, Kevin Cheung, James Ellis, Adam Duncan, Arthur Adam, Martin English, Frank Dry, Brett Robb, Roland Flanagan, Qantas, Bill Gates, UNATCO and XTC.

Printed CTP by: Offset Alpine

Distribution by: Gordon & Gotch

Customer Service Ph: 1300 65 0666

Fax: 1300 65 0777

All copyrights reserved by

Next Publishing Pty Ltd

ACN 002 647 645

ISSN 1320-7458

### WRITE TO HYPER!

78 Renwick St,

Redfern, NSW 2016

Fax: (02) 9281 6188

E-mail: freakscene@next.com.au

Hypermart: hypermart@next.com.au



ELIOT FISH >> EDITOR





## AUSTRALIAN PLAYSTATION 2 LAUNCH DATE CONFIRMED

Sony sent out a press release confirming that the Australian launch date of the PlayStation 2 would be the same as it is for Europe – October 26th. One million units will be shipped to service both Europe and Australia, so we're hoping that we don't get short-changed locally by the demand overseas. Also confirmed was that the Australian PS2 will ship with the same backside expansion unit that has been added for the American PS2. The expansion bay will be used for an upcoming hard disk and an ethernet network adapter. Unfortunately a price point was not officially confirmed. Hyper still believes we can expect to pay around \$599 for the unit, though some are saying as high as \$699!

## SONY HANDHELD RUMOURS PERSIST

The industry rumours are still flying that Sony are secretly developing a handheld to challenge Nintendo with their Game Boy monopoly. The word is that Sony are approaching game developers who have developed for Game Boy, in the hope of wooing them to their project. Some of the more outlandish rumours describe the Sony handheld as being similar to a discman, with full PlayStation compatibility. We don't think that would really be the case though, considering that the PS2 will already have backwards compatibility with the original PlayStation. We expect the real facts to stay fairly top secret for a while yet, but it makes sense that Sony would want to enter the handheld market, as opposed to just relying on PocketStation.



## RIDGE RACER V ON NINTENDO DOLPHIN!

Namco have agreed to develop Ridge Racer V for the Nintendo Dolphin. The sexy PlayStation 2 racer will be given some visual improvements and hopefully some new additions to the gameplay options for it's Dolphin incarnation. At this point in time though, the only solid information is that it's definitely happening. Maybe the Nintendo Dolphin will have the definitive Ridge Racer title... we shall see. Namco are also working on a racing title for the Sega Dreamcast, but as to what exactly that is, we can only currently guess...



AFTER RIDGE RACER R4, WE CAN RELAX KNOWING NAMCO WILL GET IT RIGHT

## PLAY PLAYSTATION GAMES ON YOUR DREAMCAST!

BLEEM! have indeed been working on a PlayStation emulator for Dreamcast, and they had it on display on the floor at E3. More important for Dreamcast owners is that not only does Bleem for Dreamcast allow you to play PlayStation games on your Dreamcast console, but it actually enhances these games MORE than the PlayStation 2 does! Bleem for Dreamcast emulates PlayStation games on the Dreamcast console, as well as adding effects to them, such as four times the resolution, anti-aliasing and special graphical effects that are not seen when running PlayStation software through the PlayStation 2! Each Bleem Pak will cost US\$20 and will enable users to play 100 different PlayStation 1 games on the Dreamcast. Users may have to purchase different packs of Bleem to get all your games to work on the Dreamcast, but the increase in visuals and performance combined with the low price make it more than worthwhile. Naturally, this is Sony's worst nightmare, and they have in fact filed a new lawsuit against Bleem! which will soon make it to court. Who's going to win this round?





**CAPTION THIS! PART 9**

Number 9. Number 9. Number 9. Ahh, well, Beatles fans will get it. You know what to do – write a screen caption for this pic and send it to [freakscene@next.com.au](mailto:freakscene@next.com.au) or post it to Caption This! Part 9, Hyper, 78 Renwick St, Redfern, NSW 2016. Good luck!



**POKEMON – GOTTA EAT 'EM ALL!**

Those curly little buggers have finally become an edible product! Pokémon the breakfast cereal is the latest thing in the USA! Kelloggs themselves have finalised a deal with Nintendo that will see Pokémon pop tarts and sprinkles making their way to our tables. Each box of cereal will come with a Pokémon giveaway of some kind, which you can bet your booty will be part of a collectable series. Gotta eat 'em all!



**OVERFLOW**

The head of Sega Japan, Shoichiro Irimajiri, recently resigned as president. New Sega boss, Isao Ohkawa, will head some major internal restructuring to ensure that business keeps keeping on. The Dreamcast is in its strongest phase currently, so the last thing Sega needs is to lose momentum.

Hideo Kojima, the creator of Metal Gear Solid 2 on the PS2, was recently quoted as saying he was a little disappointed with the PlayStation 2 hardware. "I was actually expecting something much better". Ouch, those are some serious words. Even so, he will continue to improve Metal Gear Solid 2 for its 2001 release. The game is looking incredible already.

Dave Perry, creator of Earthworm Jim and Messiah, has spoken out about the Nintendo Dolphin. "Nintendo needs to be a whole lot more aggressive this time, if they're going to dominate Sony, Sega and Microsoft." He also had some stinging comments about the upcoming Game Boy Advance – "I personally think Game Boy Advance sounds terrible". Thanks for that Dave!

Sony have secured the PlayStation 3 trademark in Japan with the Japanese Patent Office. The gaming giant is obviously planning a very rosy future.

Nintendo-loving Star Wars fans hoping that LucasArts haven't switched all their powers to the PS2, can sleep well at night knowing that they recently advertised for a lead Nintendo Dolphin programmer. Looks like Episode 2 games on the Dolphin are a done deal.

Because of bad reviews so far, there is actually a pretty funny petition on line to prevent Daikatana coming to the Mac. <http://www.utterer.com/> will show you what to do...

Oh God. Michael Jackson has been included as a playable boxer in the upcoming Ready 2 Rumble sequel being developed by Midway Games. Ready 2 Rumble Boxing: Round 2 will give fans, or maybe non-fans to punch out the "king of pop". Cool!

Remember our review of Winback on the N64? We loved that game, but it still hasn't seen a local release for some odd reason. Well, we've now heard that Koei are bringing a version of Winback to the PlayStation 2, so let's hope we get to play that one! Mmm...

**X-BOX GETS FASTER**

At E3 in Los Angeles, Microsoft turned a few heads by revealing that the specs for the Xbox had in fact increased a notch. Running at the show in the Xbox dev kits were a 733Mhz CPU as opposed to the earlier announced 600Mhz. There was also quite a bit more RAM, but that's because these were dev kits, and the extra RAM is needed for development purposes.



**SNEAK PEEK!**

Here's a first look at the Blair Witch Project survival horror PC title from Terminal Reality – due later this year!





## GETTING YOUR PS2 ONLINE

Many people have been wondering how long we're going to have to wait before we can play games online with the PlayStation 2. Well, Sony seemed to be happy to just say "wait for broadband", but when will that become available to everyone exactly? Why not pack in a modem? Thankfully, a british company, SN Systems, have developed a toolset called TCP/IP Stack which will allow game developers to provide support for USB modems in their games titles. This means that you could theoretically purchase a game that comes packed with a cheap USB modem and start playing online before we even see christmas. Of course, it requires the developer to make it an actual feature in the game, but at least it means the possibility of playing multiplayer PS2 games online with just a modem is a reality. Maybe we won't all have to wait for broadband after all...

## WINNERS

### STARLANCER

- A. Ficara, NSW
- R. Brownlow, VIC
- S. Bell, NSW
- C. Bowden, QLD
- D. Moloney, NSW

### JEDI POWER BATTLES

- Game AND video:
- D. Douglas, TAS
  - D. Leech, VIC

- J. Austin, SA
  - R. De Carvalho, NSW
  - A. Lawson, QLD
- Just game:
- J. Hubbard, SA
  - A. Hill, NSW
  - H. Curley, NSW
  - M. Turton, NSW
  - D. Maloney, NSW

### MEDIEVIL 2

- S.L. Wainwright, QLD
- C. Allen, SA
- K. McEwan, NSW
- J. Hobbs, QLD
- C. Kershaw, NSW

### SYPHON FILTER 2

- M. Stock, VIC
- S. Van Reede, NSW
- D. Ferguson, NSW
- J. New, NSW
- J. Baxter, QLD



## E.T. GO HOME

Amblin Pictures and Universal Studios have signed a contract with NewKid Co to develop new games on all platforms based upon the big 80's Spielberg hit film, E.T. The Extra-Terrestrial. Despite the fact that the only previous E.T. game, E.T. on the Atari 2600 was one of the worst videogames ever made in the history of the industry, the deal is going ahead. E.T. on the Xbox? Yeah, it seems so... Eliot will have to review that one!



## HOW MUCH IS THAT POOCHI IN THE WINDOW?

Sega Toys in Japan are releasing their new electronic dog, Super Poo-chi, in the wake of Sony's Aibo. Sega, however, plan on an electronic cat and bird also! Super Poo-chi can do everything you'd expect from a cyborg dog (what is that exactly? - Ed) as well as lie-down and sit from vocals commands. Cute, Super Poo-chi will also develop its own personality as it grows depending on how you treat it. Super Poo-chi sells for about 5980 Yen.



## CLASSIC GAMES IN YOUR BROWSER

Midway have cleverly coded some of their all-time classic games in Shockwave so you can play them for free in your browser! Ten games have so far been finished - Defender, Spy Hunter, Rampage, Joust, Defender 2, Robotron 2084, Sinistar, Bubbles, Satan's Hollow and Tapper. If you'd like to waste a few hours with these retro babies, then head over to www.shockwave.com and absorb the classic gameplay goodness.



# Racing is in your blood



Along with small pieces of  
**rock and bone.**



Satisfy your craving for dirt-bike action, head-numbing crashes and outrageous stunts on over 40 tracks in 6 events including Stunt Quarry, Nationals, Baja, Enduro, Supercross and Multi-player Tag, and get that blood of yours pumping. Download the free trial version of Motocross Madness 2 at [www.microsoft.com/games/motocross2](http://www.microsoft.com/games/motocross2)

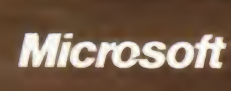



**MONEY GOOD.  
NAPSTER BAD.**



\$200 ticket  
+ \$20 compact disc  
+ \$50 t-shirt (good!)  
+ \$100 cock ring  

---

Rich-ass Metallica



## METALLICA AND THE NAPSTER DEBACLE

No doubt most of our internet roaming readers have heard of, or used a program called Napster. This doozy of an app allows users to trade mp3s with anyone else who's connected to the Napster servers, effectively creating a massive, searchable free music network. Napster has enjoyed phenomenal success, racking up 10 million registered users in its first nine months in operation alone. It's so popular that the University of Southern California recently found that Napster was responsible for 40% of all their internet traffic. Log on at any time, and you'll be able to download from a database of several hundred thousand songs. Unsurprisingly, the big boys of the record industry aren't happy about it.

The Recording Industry Association of America (RIAA) is already in the process of suing Napster over copyright infringement, as are rock demi-gods Metallica. Metallica have taken it a step further though, taking matters into their own hands and hiring a private internet detective to investigate "Metallica pirates". The result? A list of 343,000 users compiled over a single weekend (and another list a couple of weeks later). Metallica demanded that these users be banned from using the service. The backlash from fans was instantaneous and huge, especially when Napster succumbed to Metallica's demands, and banned the majority of users on the list.

Metallica have failed to understand just how influential the internet now is in shaping popular opinion. They already filed a lawsuit against the company, yet still pursued a course of action that can only be described as a stop gap measure at best. If Napster gets shut down, rest assured countless other programs will spring up that do a similar thing. Not only that, but working instructions on how to get back on Napster are freely available online. All Metallica have succeeded in doing for now is to generate a huge amount of negative press.

Other more open minded artists like Public Enemy recognise that digital distribution is not only a great promotional tool, but an innovative way to decentralise the current mode of music distribution, and get their music heard by more people than has ever been possible before. Chuck D has been an mp3 advocate for some time now, and has thrown his weight behind Napster. However, on the flip-side, another 230,000 users have been banned after Dr.Dre pressured the Napster creators. Sell out!

To add further interest to the story, in spite of numerous lawsuits and possible damage payments to the RIAA of over \$100 million US, venture capital firm Hummer Winblad recently secured a \$15 million US funding deal with Napster. What this means for Napster remains to be seen, but it's doubtful that it can continue in its current form, especially if the US congress is swayed by the recent report by the Progressive Policy Institute entitled "Napster and Online Piracy: The Need to Revisit the Digital Millennium Copyright Act". The report's recommended steps included requiring users to provide personal information before using a file sharing program like Napster and allowing judges greater freedom in granting injunctions against similar emerging technologies.

One delicious piece of irony that has arisen from all this is a quote from James Hetfield in the liner notes of Garage Inc, talking about the early days with Lars Ulrich, when he would "stay over at his house for days making tapes of his records and sleeping on the carpet". The word hypocrite springs to mind.

Our advice is to watch the Napster debate unfold as closely as possible, as this is an excellent example of the issues that the music industry will face in the future, and one of the most important cases in establishing the new rules for digital copyright in the new millennium.

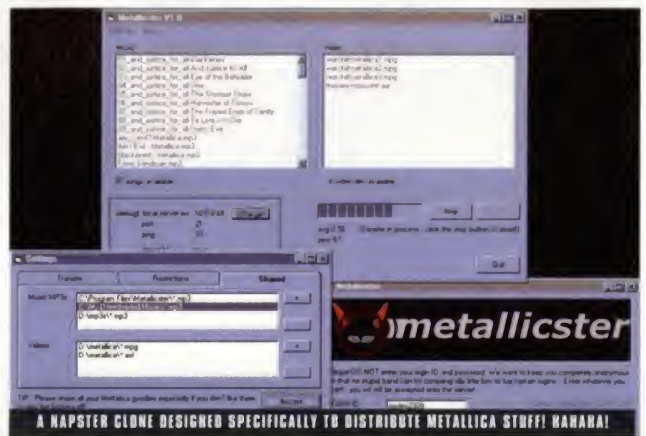

## INSANE IN THE GAME

After many years of pretending to be an OC, rapper/actor Ice T will be getting busy on a DC near you soon. Believe it or not, but Ice T is providing the voice for the lead character of a new third person sci fi action game from Monolith called... Insane in the Membrane! Pity they didn't get B Real isn't it? In any case, Ice T's character will be using psionic powers to beat off the forces of evil. Well waddaya know? His lethal weapon really is his mind!

## ANOTHER NEW CRAZE?

To add to Pokémon and Digimon, comes Fonzimon from US company, Hero Food Inc. Fonzimon are a collection of 1950's inspired gangs, which you can naturally train and fight. Discover the Bodgies, the Greaseballs, the Dodgers, the Blazers and a series of other hot-rod loving gangs who all have their own unique powers, such as Hairspray attack, Burger grease, switchblade and even plain old knuckledusters. The Fonzimon, in contrast to Pokémon, have been pitched at the 40-50 year-old age group, and can be played on mobile phones and pagers. Maybe mum and dad will get into games after all!







# POKÉMON

Gotta catch 'em all!



\$ **18<sup>95</sup>** EACH

**DURING JULY**  
**POKEMON FOSSIL**  
**THEME DECKS.**

### CAN YOU DIG UP ALL THE FOSSIL CARDS?

Two million years ago, the first known Pokemon walked the earth. Only fossils remained, and scientists thought they were extinct — until now. A remote island has been discovered in the south seas, an island where the Pokemon fossils have come to life.

Dig into the new Fossil expansion for the Pokemon trading card game. Trade with your friends, show off your favourites, build your own personalised decks and, most of all, do battle with your friends.

\$ **5<sup>95</sup>** EACH



**DURING JULY**

### POKEMON FOSSIL BOOSTER.

11 randomly inserted Pokemon cards. Features cards from Pokemon releases as well as 42 new Pokemon cards and five new trainer cards.



# Harvey Norman

THE GAMES SPECIALIST

[www.harveynorman.com.au](http://www.harveynorman.com.au)

**SHOP ON THE WEB** **Harvey Norman ONLINE**



SYDNEY METRO • AUBURN SUPERSTORE • BALGOWLAH SUPERSTORE • BLACKTOWN • CAMPBELLTOWN • CARINGBAH SUPACENTA • CHATSWOOD CHASE • GORDON CENTRE • LIVERPOOL MEGACENTA • MOORE PARK SUPACENTA • PENRITH SUPERSTORE NOW OPEN • WILEY PARK NSW COUNTRY • ARMIDALE • BATHURST • COFFS HARBOUR • DENILQUIN • DUBBO • ERINA • GRAFTON • INVERELL • LISMORE • MAITLAND • MOREE • MUDGEE • MOSS VALE • NEWCASTLE SUPERSTORE • NOWRA • ORANGE • PARKES • PORT MACQUARIE • TAMWORTH • TAREE • WAGGA WAGGA • WARRAWONG • YOUNG ACT • Fyshwick • WODEN PLAZA  
BRISBANE METRO • ASPLEY OPEN 7 DAYS • BROADWAY ON THE MALL OPENS JULY • CARINDALE • EVERTON PARK OPEN 7 DAYS • INDOOROOPIILLY NOW OPEN • MT GRAVATT • OXLEY • GOLD COAST OPEN 7 DAYS • TWEED HEADS SOUTH OPEN 7 DAYS QUEENSLAND COUNTRY • NOOSAVILLE OPEN 7 DAYS • SUNSHINE COAST OPEN 7 DAYS • BUNDABERG • CAIRNS OPEN 7 DAYS • GLADSTONE OPEN 7 DAYS • MACKAY OPEN 7 DAYS • ROCKHAMPTON NORTH • TOOWOOMBA • TOWNSVILLE MELBOURNE SUPERSTORES • OPEN 7 DAYS • DANDENONG • GREENSBOROUGH PLAZA • MARIBYRNONG • MOORABBIN • NUNAWADING • PRESTON VICTORIA COUNTRY • OPEN 7 DAYS • ALBURY • BALLARAT • BENDIGO • GEELONG • MILDURA • SHEPPARTON • TRARALGON • WARRNAMBOOL ADELAIDE • SOUTH AUSTRALIA • ENFIELD NOW OPEN • MARION OPEN MON-SAT  
PERTH METRO • CANNINGTON • JOONDALUP • O'CONNOR NOW OPEN • OSBORNE PARK • PORT KENNEDY WESTERN AUSTRALIA COUNTRY • ALBANY • BUNBURY • BUSSELTON • GERALDTON • KALGOORLIE • KARRATHA • PORT HEDLAND NORTHERN TERRITORY • DARWIN OPEN 7 DAYS HOBART METRO • OPEN 7 DAYS • HOBART CITY • GLENORCHY • ROSNY TASMANIA COUNTRY • OPEN 7 DAYS • LAUNCESTON • BURNIE • DEVONPORT • ULVERSTONE [www.harveynorman.com.au](http://www.harveynorman.com.au) The prices for goods shown in this advertisement are in Australian dollars and are GST inclusive.





# E3

Bursting through the walls of the Los Angeles Convention Centre in mid-May was this year's Electronic Entertainment Expo. If you wanted to have your head pummelled by polygons, then this was the place to be. Hyper Ed, Eliot Fish, hopped on a jet and spent three days wiping the drool off his jacket to bring you the biggest bunch of previews you'll find anywhere!

## THE GAMES OF 2000-2001

### THE GOOD THE BAD AND THE UGLY

Los Angeles is one big town. My hotel was one big hotel. The first burger slapped in front of me, was one big burger. Hold on, there's a recurring theme here. If you wanted to generalise, you could say that in America it's quantity over quality, or that bigger is better than better. After spending three days pushing my way through the

hordes at E3 2000, the same can be said about the games. There were 2,400 new titles here this year, but in actual fact there were only a handful of games that truly excelled in graphics and gameplay.

All the big players were here — Sony, Sega, Nintendo and Microsoft — plus a huge array of third party developers, everyone waving their flags and blow-

ing their whistles to try and prove to the media that they were "where it was at". As you can see from the snapshots, the booths were enormous structures worthy of a Spinal Tap concert stage dressing. Aliens hung suspended in strange liquid-filled tubes, girls wandered around in very little clothes, huge TV screens bleated and blared. Certainly, three days of E3 is too much

for any malnourished gamer to handle, yet somehow I managed to see just about everything that was worth seeing. From chatting to Lorne Lanning about Munch's Oddysee on the PS2 to stroking the silver casing of the "X-Box" and gawking at Ulala on the Dreamcast stage, there were many thrilling moments which I can now reveal to you, our dear reader...



## SONY PLAYSTATION 2

Everyone who walked through the front doors of the LA Convention Centre headed straight to the Sony booth to see the "power" of the PlayStation 2. At the end of the three days, the general consensus was that ultimately, the PS2 lineup was strangely disappointing. Graphically, the quality of the titles seemed a little inconsistent, with some titles looking a little too undercooked to be on display for all to see. However, on the flipside, if you searched the convention centre well enough, there were many very exciting titles tucked away with the third-party developers. Big games like Metal Gear Solid 2 were enough to have any gamer wetting their pants at the future of PlayStation. So what were the picks of the show for the PS2?



## ODDWORLD: MUNCH'S ODDYSEE

PS2

ODDWORLD INHABITANTS

AVAILABLE: Q2, 2001

In a private viewing, we got to see the superb animation, the intuitive 3D engine and the astounding character dynamics that we thought were only achievable from the master of game design, Shigeru Miyamoto (creator of

the Mario and Zelda games). Lorne Lanning and his Oddworld Inhabitants have the makings here of yet another brilliant action/adventure/puzzler that shows true visionary strength. Both the characters, Abe and Munch, have the ability to move about the environment with the ease and flexibility of Warner Brothers cartoon characters, despite the fact that they're bound to the potential glitchiness of a complex 3D world. The camera moves intuitively with your character so that you are never confused, lost or stuck and unlike most 3D third-person games, you'll never find a part of the environment that you can't experiment with.

## WIPEOUT FUSION

PS2

PSYGNOSIS

AVAILABLE: Q1, 2001

The fourth in the Wipeout series was presented behind closed doors, and then later brought down to the floor in the form of demo footage. Everything is pointing to this being a fantastic release. Visually, the game is stunning, with extremely solid and realistic tracks that curl away into the horizon. Everything from complete 360 degree loops and corkscrews to huge leaps of faith through cloud cover makes Wipeout Fusion look like the futuristic racer dreams are made of. Psygnosis promise 400 tracks in total for you to "finish" the game, which is quite simply mind-boggling.



## THE BOUNCER

PS2

SQUARESOFT

AVAILABLE: Q4, 2000

Just say the words "SquareSoft" and people turn their heads. Their booth was packed the entire three days as gamers craned their neck to get a glimpse at the gorgeous-looking Final Fantasy film, as well as the very promising action title, The Bouncer.



## METAL GEAR SOLID 2

PS2

KONAMI

AVAILABLE: Q3 2001

Though there was no playable version at the show, the footage that we saw was amazing enough to have people calling it the "game of the show". Most notable was the stunning realism, cinematic style and superb animation!







» **RUN LIKE HELL** Interplay rock.



» **UNREAL TOURNAMENT** Can the DualShock 2 cut it?



» **STAR WARS: STARFIGHTER** An adult Rogue Squadron.



» **DARK CLOUD** Pretty, but not as interactive as we thought.

## DRAKAN 2

PS2

PSYGNOSIS

AVAILABLE: Q1, 2001

It was surprising to hear that Drakan on PS2 was a sequel, not a port. Look forward to a whole new adventure, with the 3D engine now allowing for true seamless transitions between environments! Otherwise, this looks like what you would expect on a high-end PC.



» **DRAKAN 2** More fantasy-based romps with dragons.



» **DNI** Matrix eat your heart out.



» **DROPSHIP** A very ambitious Real Time Strategy game.



» **GT 2000** It doesn't look too far from the PSX version.



» **FORMULA X** Formula One racing just won't die.



» **THUNDERBIRDS** These guys are "go"!

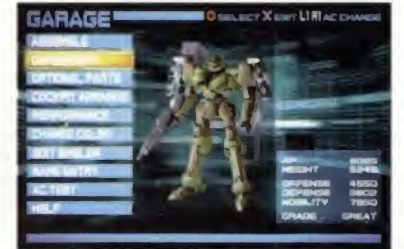

» **ARMURED CORE 2** Gorgeous.



» **MIDNIGHT CLUB STREET RACING**



» **SUMMONER** Great design in this Action/RPG!



» **THE GETAWAY** When we see gameplay...





» **SPIN** Coming from Aussie developer, Ratbag!



» **WARRIORS OF MIGHT AND MAGIC** RPG-Fest.



» **OMNIMUSHA** Some of the best FMV at the show.



» **SMUGGLERS RUN** Crazy action.



» **Z.O.E** Stunning visuals.



» **EXTERMINATION** A Sony gem.



» **FIFA 2001** Life-like animation.



» **TEKKEN TAG TOURNAMENT** Classic gameplay.



» **RIDGE RACER V** Oddly disappointing. But pretty!



» **TITANIUM ANGELS** Also coming to the PC.



» **BIS SSK** Better looking than 1080.



» **MADDEN NFL 2000** Hardcore!



» **RAYMAN 2: REVOLUTION**



» **BE ON EDGE** Seriously weird!



» **WORLD DESTRUCTION LEAGUE** Battletanx deja vu.



» **GUNSLINGERS** Activision sprung this shooter.



» **EVERGRACE** Not revolutionary, but looks pretty.





» **ETERNAL RING** First person RPG.



» **STREET LETHAL** Motoring madness.



» **LEGION: LEGEND OF EXCALIBUR**



» **DRIVING EMOTION: TYPE-S**

## PLAYSTATION

Amongst all the PlayStation 2 hype, it was easy to miss the old PlayStation. Luckily, there was still a very strong array of titles for the ageing system, which gave us faith that the PS2 will have a great back-catalogue at the very least! There were RPGs everywhere you looked amongst the old grey machines, but games like Tony Hawk's Skateboarding 2 and Colin McRae Rally 2 proved that the machine can still cut some great action! There was no doubt though, that the PlayStation was having a hard time holding it's head up amongst all the Super Consoles and great-looking PC titles. Still, check out these exciting games to look forward to!



» **LEGEND OF MANA** A sure classic.



» **TONY HAWK 2** The man is coming back. Yes!

## FINAL FANTASY IX

PLAYSTATION  
SQUARESOFT

AVAILABLE: LATE 2000

Who ISN'T looking forward to this game? Final Fantasy IX seems like it's a real return to form for the Final Fantasy series, and a sad yet wonderful way for Square to bow out of PlayStation 1 development. The classic, big-head style characters look excellent, and the gameplay looks like it'll be keeping us all up for weeks, maybe months!

Naturally, people wanted to know about Final Fantasy X and XI, but you'll need a PlayStation 2 for those babies. In the meantime, you'll be more than happy with this fantastic looking Action/RPG from the masters of console role-playing adventures.



## DINO CRISIS 2

PLAYSTATION  
CAPCOM

AVAILABLE: LATE 2000

Capcom surprised everyone by showing a sequel which actual departs from the original in style and gameplay. Of course, Dino Crisis 2 looks infinitely better!

Basically, this time around, you can expect loads more action, with Regina still in control naturally. She can carry different weapons in each hand, making for some very cool combo attacks which is a surprising change, but a welcome one! This game was scary as Hell!



» **TENCHU 2** Those Ninja assassins are back!



» **VAGRANT STORY** Could be the best RPG on PSX.



» **BREATH OF FIRE 4** Good old-school RPGing.





» **GRIND SESSION** Skate or die.



» **JUNGLE BOOK** The kids'll love it.



» **LOONEY TUNES RACING** Karting.



» **MILLE MIGLIA** Race classic cars.



» **INCREDIBLE CRISIS** Bizarre and totally brilliant.



» **CHRONO CROSS** Add another great RPG...



» **LEGEND OF DRAGOON** ...And yet another...



» **KOUDELKA** Mix one serious storyline with strategy.



» **MIKE TYSON BOXING** Mash those buttons.



» **MEDAL OF HONOUR: UNDERGROUND** Sequel!



» **MATT HOFFMAN PRO BMX** Tony Hawk-ish.



» **BLADE** Did you see the movie? Action-packed.



» **F1 2000** See, I told you it wouldn't die.



» **101 DALMATIANS** Cute.



» **ALADDIN: NASIRA'S REVENGE**



» **ANIMORPHS** Yep, the cartoon.



» **ARMY MEN: AIR ATTACK 2**





»» **DESTRUCTION DERBY RAW** Out very soon!



»» **DRAGON VALOUR** Disappointing RPG from Namco.



## CRASH BASH

PLAYSTATION  
SONY

AVAILABLE: LATE 2000

What do you mean you thought Crash Bandicoot had hit his peak with Crash Team Racing? Expanding into new game genres, Crash Bash is the Mario Party of the PlayStation.

Take all your favourite characters from the Crash Bandicoot games and throw them into this button-bashing party game for some seriously whacky fun. You'll need some brains and good reactions times though, as Crash Bash attempts to offer some more skill-based games over just plain button-mashing.



»» **HOGS OF WAR** Third-person piggy action!



»» **DUKE NUKEM & THE PLANET OF THE BABES**



»» **IN COLD BLOOD** A very ambitious adventure title.



»» **STAR WARS: DEMOLITION** Twisted Metal...



## CHASE THE EXPRESS (A.K.A COVERT OPS)

PLAYSTATION  
SONY

AVAILABLE: LAST 2000

Chase the Express is an incredibly nice surprise. At first, it seems like a poor third-person action game, but after only a few minutes playing, you'll find there's a whole lot more going on here. If you blending Resident Evil with Metal Gear Solid and put in on a fast-moving train, then you'd have Chase The Express.

Hide from patrolling guards, peer through the windows of doors, use a variety of interesting gadgets, and of course, keep that trigger finger limbered up for some frantic action also.

It's nice to see that this game is also coming to the PlayStation 2, so there will be a bigger, better version coming our way after this one...



»» **SPIDERMAN** Looking awesome!



»» **WORLD TOURING CARS: WRC**



»» **X-MEN MUTANT WARS**



»» **BUGS & TAZ TIMEBUSTERS**



»» **ARMY MEN: SARGE'S HEROES 2**



»» **MOTO RACER: WORLD TOUR**



»» **SHEEP DOG AND WOLF**





▶ **POWERSPIKE VOLLEYBALL** Extreme beach fun!



▶ **SOUL REAVER 2** Yes, another great sequel!!



▶ **STAR TREK INVASION** Surprise Activision title.



▶ **WORLD DESTRUCTION LEAGUE**



▶ **SPYRO 3: YEAR OF THE DRAGON**



▶ **X-MEN MUTANT ACADEMY**



▶ **STRIDER 2** Old-school but great.



▶ **TEAM BUDDIES** Cutesy, but full of gameplay.



▶ **RONALDO V SOCCER** Soccer fans rejoice!



▶ **TERRACON** One of many E3 games featuring Greys.



▶ **THIS IS FOOTBALL 2** The original was good enough to spawn a sequel.



## VIB RIBBON

PLAYSTATION

SONY

AVAILABLE: LATE 2000

This came out in Japan late last year, but it's only now making it to a western audience. Looks weird, eh? Well, it's a refreshingly freaky music-related title. As the music plays, it distorts the thin white line with loops, bumps, jags and drops and it's up to you to keep the character from falling or tripping up. I think we can safely assume this one is going to become a cult-hit alongside Parrappa the Rapper and Um Jammer Lammy.



▶ **THE ITALIAN JOB** Think Driver.





## NINTENDO 64

Nintendo had a very strange E3. Whilst it seemed that Sony, Microsoft and Sega were all trying to bite each other's heads off, Nintendo quietly dominated a corner of the convention centre with a sexy line-up that was true to their motto of "quality over quantity". Whether it was the cool Mario Tennis or the hilarious Conker's Bad Fur Day, to the plethora of Pokémon product and Game Boy games, Nintendo was quietly confident, you could say. The reality though, is that everyone was disappointed that there was no mention of the Dolphin or the Game Boy Advance! Ah well, it seems we'll have to wait for the Spaceworld show in Japan for that news later in the year. Meanwhile, we can enjoy some truly great Nintendo 64 games...



### DINOSAUR PLANET

NINTENDO 64  
RARE  
AVAILABLE: Q1 2001

Only announced recently, this action/adventure from Rare could give Zelda a run for it's money! This was second to only Perfect Dark in the graphics department, and the characters and story look classy!



### PERFECT DARK

NINTENDO 64  
RARE  
AVAILABLE: NOW!

Um... maybe you should just turn to our review on page 58 to see why this is the best Nintendo 64 game ever made!



### THE LEGEND OF ZELDA: MAJORA'S MASK

NINTENDO 64  
NINTENDO  
AVAILABLE: Q4 2000

Shigeru Miyamoto has kept a keen eye on the development of Majora's Mask — once known as Gaiden. Whilst it's no huge visual departure from Zelda: Ocarina Of Time, it looks like Majora's Mask has some much meatier puzzle-filled gameplay. The whole concept of morphing Link into other creatures with masks to solve his adventure is an exciting prospect.



### CONKER'S BAD FUR DAY

NINTENDO 64  
RARE  
AVAILABLE: Q1 2001

Conker kicks arse. This is one funny game, and shows Rare are still at their creative best.



**BANJO TOODIE** The sequel cometh.



**ETERNAL DARKNESS** Action/RPG.



**HEY YOU, PIKACHU** Voice controlled.



**OGRE BATTLE 64** RPG/Strategy.



**MARIO TENNIS** Classic Nintendo.



**AIDYN CHRONICLES** Ambitious.



**PAPER MARIO** Super Mario RPG 2.



**KIRBY 64** The pink freak is here!



**BLUES BROTHERS 2000** Ugh.





ARMY MEN: AIR COMBAT



MICKEY'S SPEEDWAY Karts...



SAN FRANCISCO RUSH 2049



DUCK DODGERS Looney, baby.



INDIANA JONES AND THE INFERNAL MACHINE



POKEMON PUZZLE LEAGUE Get out your wallet.



RESIDENT EVIL 0 This looked really good!



STAR WARS: EPISODE 1: BATTLE FOR NABOO



TUROK 3 Third time around for this shooter...



MEGAMAN 64 The classic MegaMan returns!



INDY RACING 2000 Fast cars.



HERCULES Beat 'em up.



## THE WORLD IS NOT ENOUGH

NINTENDO  
ELECTRONIC ARTS  
AVAILABLE: Q1 2001

Although this is actually coming to just about every gaming platform you care to mention, the fact that it will be on the Nintendo 64 and not the PlayStation is quite an interesting fact. Is it the promise of the GoldenEye cash-in, or is it because there's something in the Nintendo 64 hardware that made it worth it?



SCOOBY DOO Just like the show!



WWF: WRESTLEMANIA 2000



## SEGA DREAMCAST

Sega had a great show. Their booth was always brimming with grinning gamers, hustling to get a go at the huge array of excellent titles. Some people may think the Dreamcast can't cut it against the PS2, but they're dead wrong. Just look at these awesome games!



» **POD 2** Sequel to the PC hit!



» **WORLD SERIES BASEBALL 2K1**



» **MARVEL VS CAPCOM 2** Sexy.



» **4 WHEEL THUNDER** Monster.



» **AERO WINGS 2** For the Top Guns.



### 18 WHEELER

DREAMCAST

SEGA

AVAILABLE: LATE 2000

This rocks in the arcade, and it rocks hard on the Dreamcast. Basically, it's Crazy Taxi with a mother-flippin' 18 wheeler! What more do you want?!



### ECCO THE DOLPHIN

DREAMCAST

SEGA

AVAILABLE: JULY

The animation and environments are stunning, plus they've stuck to the good old Ecco gameplay. The atmosphere is brilliant, thanks to lovely sound and top graphics. Hopefully we'll review it next issue!



» **BOARDERZONE** Yes, THAT genre.



» **ARMAA 2**



» **DENIS THE KANGAROO**



» **DEMOLITION RACER: NO EXIT**

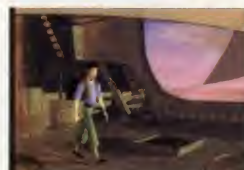

» **EL DORADO**



» **MAG FORCE** WipeOut clone...



» **JET GRIND RADIO** Truly original.



» **FUR FIGHTERS**



» **BLACK & WHITE** Wow! Stunning news that this is coming to DC!



» **BUZZ LIGHTYEAR** More cash-in.



» **CANNON SPIKE** Very arcade like.



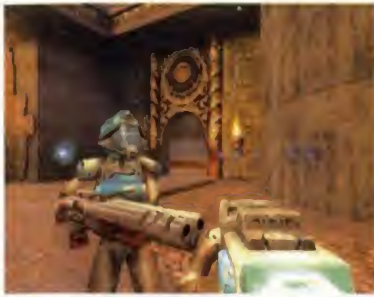

QUAKE 3 ARENA Can you wait?



BUST A MOVE 4 A classic.



D2 A long-awaited sequel...



DARK ANGEL Demonic fighting.

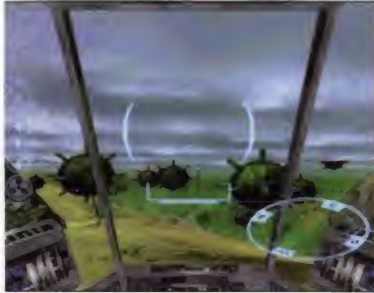

DEEP FIGHTER Underwater action.



DRAGONUS Medievil adventure.



DRAGON RIDERS OF PERN



ETERNAL ARCADIA Cool RPG.



EVIL DEAD Bruce was at the show!



EVOLUTION 2 A hearty followup.



SANITY Top Secret?



HALF LIFE Single-player only.



NBA 2K1 Even better than the first!



SEAMAN Odd.



SILVER RPG.



HEADHUNTER Survival Horror.

# OUT TRIGGER

DREAMCAST

SEGA

AVAILABLE: LATE 2000/EARLY 2001

Kind of like a third-person Quake 3 Arena, but much more extreme and arcade-like. Should be an absolute killer on the Dreamcast. Great multiplayer fun.



PROJECT EDEN They couldn't wait for PS2.



STUNT GP RACE



ILL BLEED Third person action.



SYDNEY 2000



WACKY RACES



MTV SKATEBOARDING



GAUNTLET LEGENDS



STUPID INVADERS



SEGA EXTREME SPORTS





» **GUNBIRD 2** Yet another sequel.



» **NFL 2K1** Can it beat Madden on PS2?



» **PEACEMAKERS** Strategy!



» **NFL BLITZ 2001** Total fun!!



» **SEGA GT** Sega's Gran Turismo.



» **SFR 2049** Showing promise.



» **SHENMUE** Out in time for Xmas.



» **SND CROSS** Chew through snow.



» **SPACE CHANNEL 5** ULALA!



» **SPACE RACE** More Looneyness.



» **SPAWN** Visually incredible.



» **STARLANCER** Fantastic port!

## METROPOLIS STREET RACER

DREAMCAST

SEGA

AVAILABLE: AUGUST

We've had a taste of this in the office, and we cannot wait to drive away in the final game. Take bits of Gran Turismo, but give yourself far prettier environments, and a bit more style. The car models are gorgeous and there's a lovely replay mode, of course. This is another game we hope to be reviewing for you next issue, if the developers stay on target and get the job done.



## SONIC ADVENTURE 2

DREAMCAST

SEGA

AVAILABLE: MID 2001

Yes, you read that correctly! Sonic is coming back in an all-new adventure! You can bet this game is going to be better, bigger and more beautiful than the last.

The Sonic Team have been hard at work on this since finishing the first Sonic Adventure game, so you can expect something pretty darn solid from this talented team.

We'll bring you more news as we discover more about the gameplay, but expect it to be bigger and beefier, with a few surprises.



» **STREET FIGHTER 3RD IMPACT**



» **SUPER MAGNETIC NEO**



» **TEST DRIVE: LE MANS**



» **WALT DISNEY MAGICAL RACING**



» **TONK HAWK'S SKATEBOARDING**



» **SEGA WORLDWIDE SOCCER 2000**





» TOKYO HIGHWAY CHALLENGE 2



» UFC Rules? Nah. Just win.



» V-RALLY 2 Reviewed next issue.



» VIRTUA TENNIS Arcade perfect.



» VIRTUAL ON 2 Will we get it here?



## PHANTASY STAR ONLINE

DREAMCAST  
SEGA  
AVAILABLE: LATE 2000

Massively Multiplayer Online Gaming seems to be the new trend out there. The Dreamcast will have such a game, made by Sonic Team, which will allow Action/RPGing for users all over the world. Language barriers will be broken down with the availability of symbols to communicate with as well as standard typing. The game will play in real time!



## POWERSTONE 2

DREAMCAST  
CAPCOM  
AVAILABLE: LATE 2000

You can't go past a sequel which not only pleases fans of the original, but does it with a brand new concept. Powerstone 2 is nothing like the first game, but it's fantastic in new ways. Now you can play co-operatively with a friend, rather than just concentrating on beating them senseless. The variety in Powerstone 2 is immense, and you should mark this one down on your shopping list. Capcom keep proving why they're well known for their fighting games. Are you surprised?



## SONIC SHUFFLE

DREAMCAST  
SEGA  
AVAILABLE: EARLY 2001

Another new Sonic game! This is in the tradition of Mario Party, and uses that new visual style which you may have noticed in titles like Jet Grind Radio. If you want mini-games, you got 'em, as Sonic Shuffle is literally bursting with them. This title is being developed by Sega of America for a change, so it may possibly be luke-warm on the Freak-o-meter.

Whilst we're certainly excited about this one, you can't beat the news of Sonic Adventure 2.



## STAR WARS: SUPER BOMBAD RACING

DREAMCAST  
LUCASARTS  
AVAILABLE: LATE 2000

LucasArts plan on bringing this one to the PC also, but it looks more like a console experience to us. Mix Diddy Kong Racing with Star Wars, and there you have it. Each character gets around in their trademark vehicle (Darth Maul on his Sith Speeder, Sebulba in his pod etc) and battles it out for the finish line. Powerups will help you get there, but you'll also have your own character's special individual attacks, strengths and weaknesses.



## SAMBA DE AMIGO

DREAMCAST  
SEGA  
AVAILABLE: EARLY 2001

What a classic! Sega have come up with a pair of maraca peripherals and decided that the world needs a new twist on the Dance Dance Revolution craze. Yep, shake those babies and score big points in this groovy, and yes, freaky concept for a game. We had a great time at the show watching poor punters get up on stage and humiliate themselves.



## PC

E3 never fails to reveal some stunning PC games which hadn't previously been on the release schedule. Hitman, Fallout Tactics, Empire Earth... there are some great looking titles on the way. We also finally got to play Warcraft 3, Daikatana, Black & White, Return To Castle Wolfenstein and Diablo 2, plus have a good chat with Warren Spector, Chris Roberts, Will Wright and some other PC game design gurus. Now take a look at what we saw...



### BLACK & WHITE

PC  
EA  
AVAILABLE: LATE 2000

Peter Molyneux was there to guide us through this remarkable looking game. The Artificial Intelligence in Black & White is stunning, with each individual villager having a personality. In fact, personality plays a huge part, as your giant creature will adapt depending on YOU...

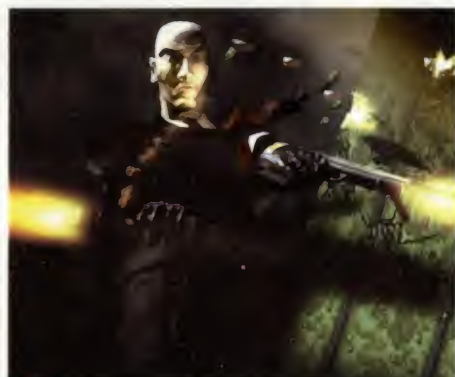

»» **HITMAN** Ambidextrous assassin action.



»» **DEUS EX** An undeniable classic! Huge.



»» **CLEOPATRA**

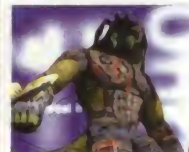

»» **UNREAL 2**



»» **X-COM: ALLIANCE** Looks good!



»» **EMPIRE EARTH** Stunning title.



»» **ESCAPE FROM MONKEY ISLAND**



»» **WARCRAFT 3** More of the same.



»» **FREELANCER** Epic space adventure.



»» **ZEUS** Bearded guy with lots of power.



### SACRIFICE

PC  
INTERPLAY  
AVAILABLE: Q1 2001

"Sacrifice has been in development for two and a half years. It's Shiny's first multiplayer PC game. It's a 3D real-time action strategy game with RPG elements. Basically, a game that you can play as you want to play it. Whether you're a strong RPG player or you prefer action, you can adapt the control system and the way that you use the creatures and the characters in the game to suit your style of play." — Shiny Entertainment.

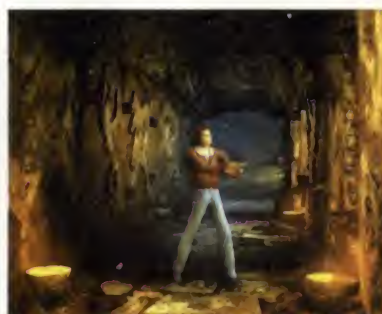

»» **ALONE IN THE DARK** Cinematic!



»» **ANACHRONOX** More from Ion Storm.



»» **ARCANUM** Industrial fantasy RPG.



»» **BALDURS GATE 2** It's coming.



»» **STAR TREK BRIDGE COMMANDER**



»» **CARMAGEDDON TOR 2000**





» **COLIN MCRAE RALLY 2** Brrrrrm!



» **COMMANDOS 2** Pop those Nazis.



» **CONQUEST** Yet more space strategy.



» **CRIMSON SKIES** Dogfighting is fun!



» **GANGSTERS 2** Cement shoes ahoy.



» **DUNGEON SEIGE** Huge gameworld.



» **EVOLVA** Worthy of Dave Perry.



» **F1 WORLD GP 2000** Ahhhhhhhhhh!



» **FALLOUT TACTICS**



» **DIABLO 2** Can you say "review next issue"?



» **GIANTS** Another game with true style!



» **GRAND PRIX 3** Is it the best ever?



» **GROUND CONTROL 3D** RTS action.



» **HALO** Multiplayer FPS heaven!



» **HEROES CHRONICLES** More M&M.



» **HOMEWORLD CATAclysm** Epic.



» **I'M GOING IN** GoldenEye meets Soldier of Fortune.



» **LOOSE CANNON** Interstate '82 meets Driver.



» **ICEWIND DALE** RPG from the masters of PC RPGs.





»» **CALL TO POWER 2** Space strategy.



»» **MEGAMAN LEGENDS**



»» **METAL GEAR SOLID**



»» **PGA CHAMPIONSHIP GOLF 2000**



»» **PROFESSIONAL BULL RIDER**

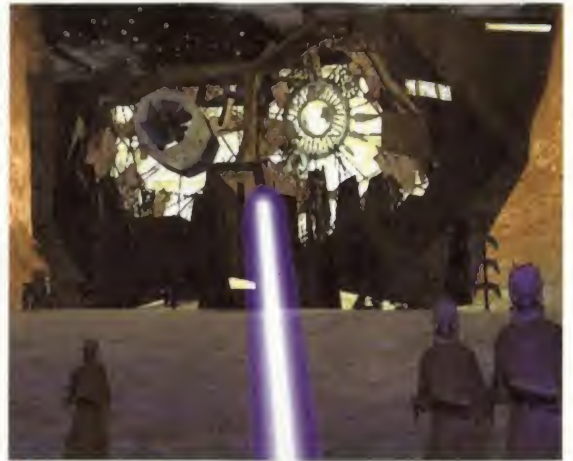

»» **OBI-WAN** Designed for third-person play it seems...

## I-WAR 2

PC  
INFOGRAMES

AVAILABLE: LATE 2000

People couldn't keep their hands off this game at the show, as it was stunningly beautiful and had all the meaty interactivity of the original. It was also displayed on a gorgeous widescreen digital monitor! Sure to please the space combat buffs, Independence War 2 has nothing to do with Will Smith and aliens blowing up America. Just remember that. I-War 2 is far more intellectual...



»» **MECHCOMMANDER 2** If you liked the first, you'll love it.



»» **INSANE** Codemasters know fun.



»» **LINKS 2000** Golf your night away.



»» **MIDTOWN MADNESS** Scary stuff.



»» **NASCAR RACING 4** Burn rubber.

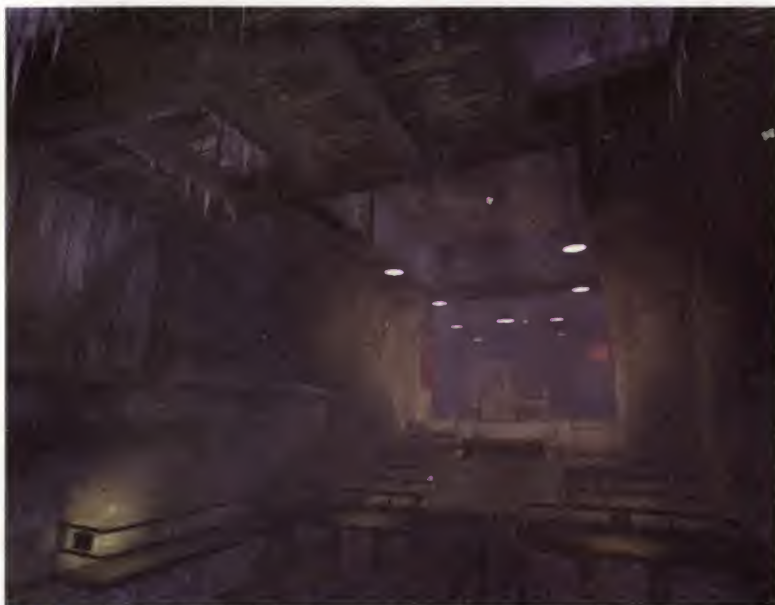

»» **RETURN TO CASTLE WOLFENSTEIN** Kill the guard get the key. Is it still fun?



»» **STAR TREK: AWAY TEAM** Engage!



»» **QUAKE 3: TEAM ARENA** Drool!



»» **ULTIMA WORLDS ONLINE: ORIGIN**



»» **STAR TREK: NEW WORLDS**





# TRIBES 2

PC  
DYNAMIX  
AVAILABLE: Q1 2001

Tribes made a bigger dent in Quake 2's multiplayer dominance than anyone thought it would. That's simply because it was a squad-based game which did everything Quake 2 couldn't. Tribes 2 is set to come along and wipe the floor with both Quake 3 and Unreal Tournament, with its immersive teamplay action. If you plan on playing Tribes 2 (and you should), go out and buy yourself a headset so you can do the whole serious team thing at your next LAN. It's the way this game was designed to be enjoyed. The environments look massive, and whilst the visuals certainly are a big improvement over the original, the meat of the changes have been made to improving performance online and adding more options than you can point a gun at.



» **VAMPIRE THE MASQUERADE REDEMPTION** Review next issue of this gothic RPG.



» **STARTOPIA** Freaky.

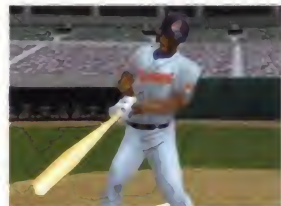

» **MICROSOFT BASEBALL 2001**



» **VIRTUAL POOL 3**



» **MUSIC 2000**



» **C & C: RENEGADE** No longer top-down.



» **NEVERWINTER NIGHTS**



» **LEGENDS OF MIGHT & MAGIC**



» **SPRINT CAR RACING** From RatBag.



» **STARFLEET COMMAND 2**



» **ANARCHY ONLINE** Go nuts!



» **RED ALERT 2** Command & Conquer.



» **WIZARDS AND WARRIORS**



» **HEAVY METAL F.A.K.K. 2**



» **THRONE OF DARKNESS**



» **BATTLEREALMS** A Fantasy romp.



» **STAR TREK VOYAGER ELITE FORCE**



## GAMEBOY

Tucked away amongst the mountains of Pikachu toys, Nintendo had their money-making Game Boy games on display for all to evaluate and even purchase if you so desired. Of course, the exciting new titles like *Zelda: The Mystical Seed* were only for looking, maybe touching, but definitely not for taking to play on the long flight home... Goddamnit. They even had Game Boy "babes" to help you find that magical gauntlet. We asked very nicely, but none of them would tell us anything about the Game Boy Advance. Maybe it was because they had no idea what it was, or possibly they were cleverly avoiding my deviously worded probings.

Almost all the games publishers at the show had some Game Boy up their sleeve, which just goes to show you how successful this little device has been. Nintendo could probably exist on the Game Boy alone.



▶▶ **XTREME SPORTS** Woah dude!



▶▶ **ALONE IN THE DARK** Spooky.



▶▶ **ARMY MEN 2** Play with soliders.



▶▶ **ARMY MEN AIR COMBAT**

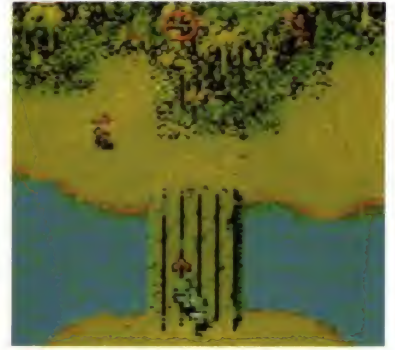

▶▶ **CANNON FODDER** The PC classic.



▶▶ **CRYSTALIS** Another RPG cometh.



▶▶ **DRIVER 2** Mini mafia motoring.



▶▶ **HARVEST MOON 2** Famboy Link.

## DONKY KONG COUNTRY

GAME BOY COLOR  
NINTENDO

AVAILABLE: LATE 2000

Wow, we played it on the Super Nintendo, and now we'll be revisiting banana land on the Game Boy. Who would have thought? The Kremlings are still causing trouble, and if you have a Game Boy Color, you'll be able to help Donkey and Diddy put a stop to their evil schemes. This is a great platformer, and you'll be hard pressed to find any better on the Game Boy. Rare know how to make something fun, playable and challenging, so we applaud them for bringing this to the hand-held. And to think this was once a state of the art console game...



▶▶ **HERCULES** Beefcake! Beeefcake!



▶▶ **INSPECTOR GADGET** Go Gadget.

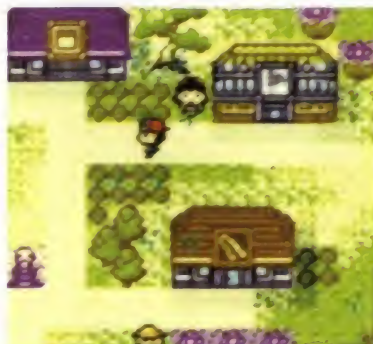

▶▶ **LEGEND OF THE RIVER KING**



▶▶ **LITTLE MERMAID 2** Er... yeah.



▶▶ **LOONEY TUNES COLLECTOR ALERT**





## THE LEGEND OF ZELDA: THE MYSTICAL SEED

GAMEBOY COLOR

NINTENDO

AVAILABLE: LATE 2000

Any gamer with half a brain would consider going to buy a Game Boy Color just to be able to play these mini-Zelda classics. *Mystical Seed* is the first in a new trilogy of Zelda games on the Game Boy and we cannot wait to get our hands on a final (and English translated) version. It was great fun to play around with at the show, but the booth babes were useless when I started crying about the Triforce. Shortly after I was escorted from the convention centre. Ah well.



## POKEMON GOLD/ SILVER

GAME BOY

NINTENDO

AVAILABLE: LATE 2000

Don't think for a second that this year would pass without new Pokémon Game Boy titles! Pokémon Gold and Pokémon Silver will be the two new companions to Pokémon Blue and Pokémon Red.



## PERFECT DARK

GAMEBOY

RARE

AVAILABLE: LATE 2000

Well, we didn't think they could do *Metal Gear Solid* on Game Boy but we were wrong! *Perfect Dark* actually looks like it will be packed with interesting gameplay, regardless of the hand-held format.

Just think — your own pocket Joanna to play with any time you please!



» RUNELORDS More adventuring.

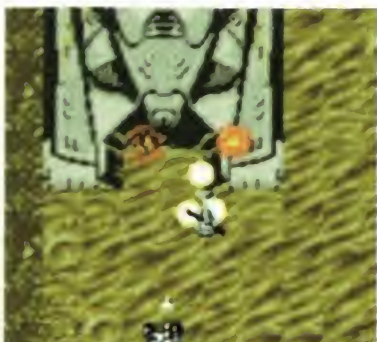

» SWIV Another old classic returns.



» POCKET SOCCER Small balls!



» PRO POOL Become a shark.



» WACKY RACES Remember this?



» WARLOCKED RTS on the Game Boy.



» TEST DRIVE LE MANS Fast cars.

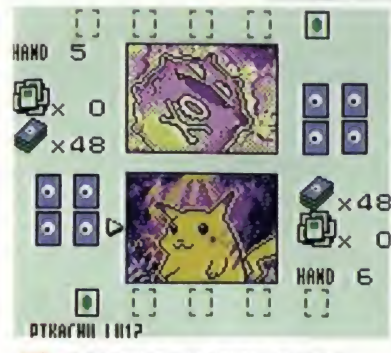

» POKEMON TRADING CARDS



SHEARER

» UEFA 2000 More ball kicking.



» WARIO LAND 3 W is M upside down.



» KENA WARRIOR PRINCESS



» TITUS THE FOX A platformer! Shock!



# EVERY SUBSCRIBER GETS A PRIZE!

**Subscribe to Hyper and receive 2 Star Wars PC Games Discs!**

*If you subscribe to Hyper magazine this month, you'll be getting Australia's best games mag way before it hits the shops and much cheaper too! Subscribing is like getting a handful of free issues every year, so you're nuts to not consider getting your Hyper sooner and cheaper! As a bonus this month, we're giving away 2 copies of PC Games, the best of Star Wars, to EVERY subscriber! That's right, two discs packed to the brim with Star Wars action for FREE!*

**Just subscribe!**

**WINNER FROM HYPER #80**  
**Prize: SEGA DREAMCAST with Dead or Alive 2**  
**ANTHONY VERTIGAN, VIC**

HYPER #82 Terms and Conditions  
 Terms and Conditions: 1. Each person subscribing from Hyper issue 82 only will receive a one year subscription to Hyper, plus one copy of PC Games issue 8 plus one copy of PC Games issue 19 which will be sent 4-6 weeks after the first Hyper magazine has arrived. The offer is open only to those subscribing from issue 82 on sale 21st June. Offer begins 21st June and ends 31st July. The promoter is Next Publishing Pty Ltd. ABN 88 002 647 645 of 78 Renwick Street, Redfern, NSW, 2016



**HOW TO SUBSCRIBE**

Call us tollfree on

**1 1300 36 1146**

Monday to Friday  
 9am-6pm EST

Fax a copy of the completed form, with credit card details, to:  
**02 9699 0334**

Cut or copy the form and post it with a cheque or money order, or your credit card details, to:  
**Hyper Subscriptions**  
**Reply Paid 634,**  
**78 Renwick St.**  
**Redfern, NSW 2016**

check out our website at  
<http://publishing.next.com.au/subs>

**Please tick**

I'd like to subscribe for myself   
 I'd like to send a gift subscription   
 12 issues @ \$50.00   
 (\$55 inc. GST - after and inc. 1st July, 2000)

Enclosed is a cheque/money order made payable to Next Publishing for \$.....

Or charge my credit card for \$.....

Visa  Mastercard  Bankcard

Card Number.....

Expire Date.....

Signature.....

Offer only available to Australian Residents. Expires 31.7.00

**Please print**

**»HY0082**

My Full Name.....

My Address.....

Suburb..... Postcode.....

My Telephone Number.....

My Email Address.....

Please send a **HYPER»** magazine subscription to

Full Name.....

Address.....

Suburb..... Postcode.....

Telephone.....

TAX INVOICE Next Publishing Pty Ltd.

78 Renwick St, Redfern, NSW 2016 ABN 88 002 647 645





# READY, AIM, FIRE!

**PERFECT DARK™**

NINTENDO 64  
Only For

EXPANSION PAK REQUIRED  
FOR MAXIMUM GAMEPLAY!  
(SEE BACK FOR INFO)

Compatible with  
N64 Controller Pak™  
N64 Rumble Pak™

1-4 Player/Simultaneous\*

MA 15+  
MEDIUM LEVEL  
ANIMATED VIOLENCE

PUBLISHED BY  
RAREWARE

DO COEBY  
SOUND



Bring in a copy of  
this ad and pay  
only

## Perfect Dark (MA15+).

# \$78<sup>95</sup>

Perfect Dark offers a traditional 2-4 player deathmatch mode. Choose from over 40 unique weapons, take aim and fire. An intriguing storyline, an enticing leading lady and awesome gameplay combine to form an irresistible package.

Offer valid from 1st July  
to 31st July 2000.

# Harvey Norman

THE GAMING SPECIALISTS

SOFTWARE  
PRICE  
GUARANTEE\*

[www.harveynorman.com.au](http://www.harveynorman.com.au)

SHOP ON THE WEB Harvey Norman ONLINE

SYDNEY METRO • AUBURN SUPERSTORE • BALGOWLAH SUPERSTORE • BLACKTOWN • CAMPBELLTOWN • CARINGBAH SUPACENTA • CHATSWOOD CHASE • GORDON CENTRE • LIVERPOOL MEGACENTA • MOORE PARK SUPACENTA • PENRITH SUPERSTORE NOW OPEN • WILEY PARK NSW COUNTRY • ARMIDALE • BATHURST • COFFS HARBOUR • DENILQUIN • DUBBO • ERINA • GRAFTON • INVERELL • LISMORE • MAITLAND • MOREE • MUDGEE • MOSS VALE • NEWCASTLE SUPERSTORE • NOWRA • ORANGE • PARKES • PORT MACQUARIE • TAMWORTH • TAREE • WAGGA WAGGA • WARRAWONG • YOUNG ACT • FYSHWICK • WODEN PLAZA  
BRISBANE METRO • ASPLEY OPEN 7 DAYS • BROADWAY ON THE MALL OPENS JULY • CARINDALE • EVERTON PARK OPEN 7 DAYS • INDOOROOPIILLY NOW OPEN • MT GRAVATT • OXLEY • GOLD COAST OPEN 7 DAYS • TWEED HEADS SOUTH OPEN 7 DAYS QUEENSLAND COUNTRY • NOOSAVILLE OPEN 7 DAYS • SUNSHINE COAST OPEN 7 DAYS • BUNDABERG • CAIRNS OPEN 7 DAYS • GLADSTONE OPEN 7 DAYS • MACKAY OPEN 7 DAYS • ROCKHAMPTON NORTH • TOOWOOMBA • TOWNSVILLE MELBOURNE SUPERSTORES • OPEN 7 DAYS • DANDENONG • GREENSBOROUGH PLAZA • MARIBYRNONG • MOORABBIN • NUNAWADING • PRESTON VICTORIA COUNTRY • OPEN 7 DAYS • ALBURY • BALLARAT • BENDIGO • GEELONG • MILDURA • SHEPPARTON • TRARALGON • WARRNAMBOOL ADELAIDE • SOUTH AUSTRALIA • ENFIELD NOW OPEN • MARION OPEN MON-SAT  
PERTH METRO • CANNINGTON • JOONDALUP • O'CONNOR NOW OPEN • OSBORNE PARK • PORT KENNEDY WESTERN AUSTRALIA COUNTRY • ALBANY • BUNBURY • BUSSELTON • GERALDTON • KALGOORLIE • KARRATHA • PORT HEDLAND NORTHERN TERRITORY • DARWIN OPEN 7 DAYS HOBART METRO • OPEN 7 DAYS • HOBART CITY • GLENORCHY • ROSNY TASMANIA COUNTRY • OPEN 7 DAYS • LAUNCESTON • BURNIE • DEVONPORT • ULVERSTONE [www.harveynorman.com.au](http://www.harveynorman.com.au) The prices for goods shown in this advertisement are in Australian dollars and are GST inclusive. \*We will match any retailer's price on a like software item. The software item must be in stock. An original copy of an advertisement for the software item must be presented, including price. The advertisement must be current. This does not include mail-order catalogues or Internet sites. Pricing presented must be in Australian dollars.



## DREAMCAST GOES PERIPHERAL CRAZY!

Sega revealed new peripherals for Dreamcast at E3 in Los Angeles including an MP3 Player, LAN adaptor, Video Conferencing unit, Mouse and DVD Player!

Whilst many have pondered how the Dreamcast is going to fare against the DVD equipped PS2 and X-Box, Sega have been working on solutions. One of those is a DVD player add-on! If you've also had an issue with the measly 33k modem, then look forward to the LAN adaptor! The goodness doesn't stop there. Also on the way is an MP3 player and the DreamEye video conferencing unit.

Sega's LAN adaptor will allow users to connect to cable modems for high-speed transfer of data. This will allow music and video to be streamed in real time as well as enabling graphic-intensive web pages to load in seconds. Not only will this improve your surfing and open up the possibility for cool new downloads to your VMU or upcoming Dreamcast harddisk, but it will change the way we play games online with our Dreamcasts.



The MP3 player is Sega's peripheral that allows users to download MP3 files off the Internet and store them in a portable player. The device comes with a set of headphones and can also use the Dreamcast GD ROM drive to place songs into the MP3 player's memory!

The Dreameye, Sega's Video Conferencing unit, allows Dreamcast users to connect to other Dreamcast owners over the Internet or via direct dialling and send full motion video and sound through the Dreameye's digital camera and microphone. The Digital camera is also detachable and can be used to take up to 31 images, which can then be transferred online via the Dreamkey's email software.

The Mouse will allow Dreamcast users to re-create their PC control environment in games like Quake 3, Half Life and the upcoming Soldier of Fortune conversion for Dreamcast. On display with the Quake 3 game units at E3, the mouse afforded users the smooth control that PC users have been accustomed to with 1st person shooting games like Quake. We sat down for a blast session at E3 and found that it made quaking on the Dreamcast virtually identical to the PC experience which is a first for console based shooters! Finally, we can forget about having to struggle with the control pad in first person.



Most importantly, the DVD player will allow Dreamcast users to play DVDs through their Dreamcast console. The exact technical details of how this will work haven't been officially confirmed by Sega, but it seems to be a DVD drive which sits under the Dreamcast and plugs into the modem port. The Dreamcast modem port operates at 50MB/s which is fifty times that which is needed for DVD playback, so it should work marvellously. Now we just have to cross our fingers that all these add-ons will be available in Australia before too long...



THE MP3 PLAYER



extreme  
rally  
racing



PlayStation

PAL



colin|mcræe|rally|2.0

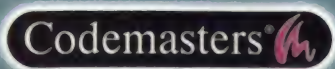

PlayStation

PlayStation®

\$77.95†



When you present an original copy of this advertisement at any Harvey Norman computer department from July 1 to July 31 2000.

Conditions apply. See store for details.

**Colin McRae Rally 2 PSX (G).**  
Experience jaw-dropping visuals, even more detailed cars and incredible scenery as you race on over 80 new international rally tracks. Drive hard, contend with the constantly changing weather and take the cars to the edge of control; but go over the edge and you'll soon discover the out-of-control damage effects. PCOL11PSX

**Harvey Norman**

THE GAMES SPECIALIST

[www.harveynorman.com.au](http://www.harveynorman.com.au)

**SHOP ON THE WEB** **Harvey Norman ONLINE**

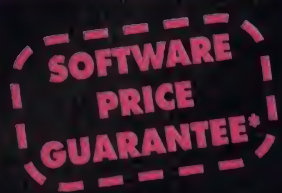

SYDNEY METRO • AUBURN SUPERSTORE • BALGOWLAH SUPERSTORE • BLACKTOWN • CAMPBELLTOWN • CARINGBAH SUPACENTA • CHATSWOOD CHASE • GORDON CENTRE • LIVERPOOL MEGACENTA • MOORE PARK SUPACENTA • PENRITH SUPERSTORE NOW OPEN • WILEY PARK NSW COUNTRY • ARMIDALE • BATHURST • COFFS HARBOUR • DENILIQUIN • DUBBO • ERINA • GRAFTON • INVERELL • LISMORE • MAITLAND • MOREE • MUDGE • NEWCASTLE SUPERSTORE • NOWRA • ORANGE • PARKES • PORT MACQUARIE • TAMWORTH • TAREE • WAGGA WAGGA • WARRAWONG • YOUNG ACT • FYSHWICK • WODEN PLAZA BRISBANE METRO • ASPLEY OPEN 7 DAYS • CARINDALE • EVERTON PARK OPEN 7 DAYS • INDOOROOPILLY OPENS APRIL • MT GRAVATT • OXLEY • GOLD COAST OPEN 7 DAYS • TWEED HEADS SOUTH OPEN 7 DAYS QUEENSLAND COUNTRY • NOOSAVILLE OPEN 7 DAYS • SUNSHINE COAST OPEN 7 DAYS • BUNDABERG • CAIRNS OPEN 7 DAYS • GLADSTONE OPEN 7 DAYS • MACKAY • ROCKHAMPTON NORTH • TOOWOOMBA • TOWNSVILLE MELBOURNE SUPERSTORES • OPEN 7 DAYS • DANDENONG • GREENSBOROUGH PLAZA • MARIBYRNONG • MOORABBIN • NUNAWADING • PRESTON VICTORIA COUNTRY • OPEN 7 DAYS • ALBURY • BALLARAT • BENDIGO • GEELONG • MILDURA • SHEPPARTON • TRARALGON • WARRNAMBOOL ADELAIDE • SOUTH AUSTRALIA • ENFIELD NOW OPEN • MARION OPEN MON-SAT PERTH METRO • CANNINGTON • JOONDALUP • O'CONNOR NOW OPEN • OSBORNE PARK • PORT KENNEDY WESTERN AUSTRALIA COUNTRY • ALBANY • BUNBURY • BUSSELTON • GERALDTON • KALGOORLIE • KARRATHA • PORT HEDLAND NORTHERN TERRITORY • DARWIN OPEN 7 DAYS HOBART METRO • OPEN 7 DAYS • HOBART CITY • GLENORCHY • ROSNY TASMANIA COUNTRY • OPEN 7 DAYS • LAUNCESTON • BURNIE • DEVONPORT • ULVERSTONE The prices for goods shown in this advertisement are in Australian dollars and are GST inclusive.

†We will match any retailer's price on a like software item. The software item must be in stock. An original copy of an advertisement for the software item must be presented, including price. The advertisement must be current. This does not include mail-order catalogues or Internet sites. Pricing presented must be in Australian dollars.



# ↳ The Future



**Eliot Fish** and Hyper's UK correspondent **Derek dela Fuente** got on the blower and tracked down consoles, the future of the PC and the future of gaming in general... some of their responses will surprise, games developers think of the consoles? Have you always wanted to know what kind of ambitions they have for





of gaming  
part one



the biggest names in the games industry (from 3DFX to Electronic Arts) and then grilled them over the super some will delight and some will downright knock your socks off! Have you always wanted to know what the the future of gameplay? Then read on and discover some true opinions in one of our biggest features yet...



## HERE'S WHAT WE ASKED THEM!

1. What are your impressions of the Dreamcast, PlayStation 2 and (from what you know) the X-Box and the Nintendo Dolphin?
2. Where does the PC fit into this new oncoming console era?
3. When and what do you think will be the next revolution in game design?
4. Will all this new hardware result in only a visual improvement to games or will we see gameplay evolve too?
5. Tell us about a game (or a game concept) you're working on now for one of the new systems.
6. In a nutshell, what do you think the future of Gaming looks like? (VR headsets? Neural implants?) Discuss!

**LORNE LANNING**  
Oddworld  
Inhabitants  
(the genius  
team behind  
Abe and the  
Oddworld  
games!)

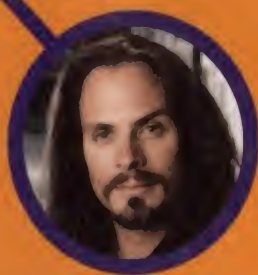

1. Dreamcast is the most powerful system on the shelf today. However, when the PS2 gets here, it's a whole different ball game. The PlayStation 2 is a very serious machine that we are very excited about. However, it is very difficult to program for and has some funky limitations that make it clear it was designed by engineers who don't understand how to make great looking computer graphics. It's causing a lot of extra work to get around some basic technical oversights. But in the end, it's still one hell of a machine, and I'm sure it will live a fabulous life. The X-Box is an even more serious machine with even more potential. Let's hope Microsoft delivers what they promise. If they do, then gaming has even more potential. All that the world needs now is more designers that are creative and take advantage of these new and powerful machines (PS2 & X-Box) to create truly new experiences

- unlike the most recent stuff that was shown at the Tokyo Game Show. As for the Dolphin, it seems as though Nintendo has made it clear that they are a toy company only and have no interest in being a true media entertainment company. They want to keep making machines with limited potential so that they can keep control over game developers and publishers while enforcing those insanely high manufacturing costs. The Dolphin is not on our radar screens.

2. Good question. It's not clear at all how the PC is going to be able to compete with consoles like the X-Box. PC game sales are dropping while consoles keep increasing. We don't think that PC games are going to go away, but more and more PC game developers are setting their sights on machines like the PS2 and X-Box. If you go to a Sony PS2 technical conference, more than half of the audience are PC developers who are changing gears. They know they can sell more games on console, and now that they're able to build more of the games they want on these new consoles... it's going to be a very interesting next couple of years. We will keep converting our games to PC as long as the power is there to properly deliver the vision of the game.

3. I believe it will happen this year with the release of Munch's Oddysee. I also think Black & White will open new doors. Fully simulated self aware worlds are the future.

4. Most people are not evolving gameplay. There are a couple of solid reasons for this. As game costs rise publishers are more adverse to taking risks with creative concepts that haven't been proven. Also, if you see what's going on out there, the game design community just doesn't appear to be injecting much new creativity. So, most games will look better, but will be the same old game. Just like what we saw from Tokyo last week. However, a few games will break the mold and will be such rich and entertaining experiences that the bar will be raised and a new generation of game design will follow.

5. Oddworld: Munch's Oddysee will be more focused on world simulation and the behaviours of characters and eco-systems to achieve much more "living" impressions. We are simulating entire life cycles for all the characters in the world, all the communities, and even the landscape. We are truly going for a "world" simulation approach rather than gauntlet types of puzzles that you saw in our previous games. We are also spending a ton of effort in advanced behavioural, simulation, and social chemistry models. GameSpeak(tm) will also now allow you to move around and manipulate a large number of characters in order to have them do your bidding and re-shape your landscape. GameSpeak has become more highly

evolved and smarter, but simpler to understand and make use of. Munch's Oddysee is a gene splicing of Action, Adventure, RPG, Strategy, and emulation, with Hollywood storytelling and production value sprinkled all over it. It is quite difficult to describe this when nothing quite like it has been done before - to see and play will be to believe. As for familiarity of this universe to previous fans, the good news is that this has been planned from the beginning. Meaning, we introduced Abe(tm) and Oddworld in 2D while always planning to evolve them into 3D when the technology was there. So it's not like we're developing an after-thought. The creativity and the conceptual qualities are completely in sync with the universe we've developed thus far. In the final analysis, we believe that existing fans will be much happier about the oddness of Oddworld in 3D than they ever could have been in 2D. I can't imagine that anyone will say, "But ya know, I really liked the old 2D games from Oddworld better." I guess we feel that the PlayStation2 3D world of Oddworld is far more "Oddworld."

6. How far into the future? Near term is controllers. Mid term is eyeglasses. Long term is a multitude of options including Neural Implants for those crazy enough to do it. But this is purely hardware, it's the software side of things that will become really interesting. Like all those digital sexual peripherals that will inevitably arrive.

**TOM SARRIS**  
LUCASARTS

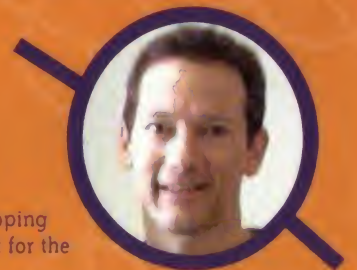

1. Based on early reports, these systems, like Dreamcast, appear to be very viable. As such, LucasArts will consider developing titles for them, while continuing development for the PC platform.

2. One of LucasArts' core legacies is development for the PC and we foresee a very comfortable coexistence between that platform and next generation consoles moving forward. The bottom line is that LucasArts will support all viable platforms as it has in the past.

3. That's no easier to predict than the next hot Internet stock! Do you have any good tips? In seriousness, one of the next phases of gaming we foresee as taking interactive entertainment to another level is the Internet. Verant Interactive has proven with EverQuest that there is





a strong market for massively multiplayer online games. That's why we think the time is right to develop a Star Wars Online title, something which we just announced in partnership with Verant and Sony Online Entertainment. We expect that title to be ready in late 2001.

4. Both, considering the sheer power and technical capabilities that are expected with each of the next generation systems. It's been seen in the past that with an improvement in technology come breakthroughs in gameplay. The expected Internet components of the upcoming next generation systems should have a profound effect on gameplay and the way people play games.

5. LucasArts have announced many exciting new games at the E3 tradeshow in Los Angeles. Starfighter, Battle For Naboo, Escape From Monkey Island... the list goes on!

**RORY DUNCAN**  
Developer/Relations Manager for 3DFX  
(The people who are making the 3D graphics cards that we all want!)



1. I think they're very good examples of the evolution of gaming taking place in the console market right now. By using sub-sets of today's PC technology, players in this market can produce products that appeal to a mass audience. This is generally a good idea, as the more people adopt gaming technologies, the bigger the market becomes and the more pervasive this technology is, etc. etc. There's certainly no beating them for 'pick up and play' appeal.

2. As ever, the PC continues to push the boundaries of technical innovation which the consoles then distil and fit into a dedicated box. The problem is, though, that no matter how advanced a console is, six months later it will have been overtaken in terms of power, performance, and ultimately the total playing experience, by the open design of the PC. What many people don't realise is that ALL games titles, whether destined for platform or not, are designed, created and programmed on PCs.

3. I don't really have an answer to that one, I'm afraid.

4. The visual improvement is brought about by increases in speed and power of chip, and associated, technologies. But this is a general improvement also - CPU core speed, peripheral enhancements, networks, storage etc. etc. will all contribute to the evolution of gameplay. Faster access to more information, players, interaction, feedback etc. will multiply the opportunities for fresh gaming experiences. Imagine, for example, playing a RTS game where armies are made up of thousands of individual players controlling one soldier or orc or whatever each. Suddenly, gameplay issues such as effective use of communications or distribution of equipment or the effect of morale on the success of a battle will become more important - perhaps a more realistic, immersive experience of war?

5. Not applicable.

6. In the short-term, nothing dramatic will happen, but in the medium-term, we will see more use of WAP devices and set-top boxes as the main means by which the average consumer, especially new users, will access interactive entertainment. In general, wires and cabling will become redundant as wireless and/or infrared communications becomes more practical.

Hardcore gaming will continue to push the boundaries of the immersive experience, using the latest technologies. However, while controllers/joysticks will become more sophisticated and sensitive, it's difficult to see the QWERTY keyboard being usurped by any other device as the primary means for inputting complex information - look how long it's been around, and what some of the other options have been.

It's realistic to say that viewing screens will become larger and have higher resolutions - maybe 3D glasses will also catch on in a big way.

I think it's fairly safe to say that any type of intrusive technology (implants etc.) are very far off, if they even get adopted at all. There is a psychological barrier to this kind of thing - we need to feel secure in the ability to turn even the most realistic simulation 'off' e.g. the Star Trek Holodeck has 'safety protocols' and 'exit commands'!

**PETER MOLYNEUX**  
(Mr Visionary only had time to answer a few questions. He was trying to finish his upcoming game, Black & White.)



1. Well the PS2 is a coders dream with all that power but I feel it will be many years before we see people push the machine to it's limits. I'm sure there will be some incredible games on it whereas the X-Box is more familiar to me but I am excited by all the new systems. The early release of Dreamcast is an advantage for Sega as the developers are only now getting to used to the system and all it can do - there will be some great games for it while on the new consoles it will take some time and some games release before we can see what the other machines are capable of. The hard disk on the X-Box is great for paging in and out of graphics and game levels which also means that the game world on an X-box will have higher-res textures. It's a great scratch storage service.

As for the DVD drives on the X box and PS2 the main thing it will offer the gaming world is an increased potential audience as the DVD player will encourage people who wouldn't normally buy a console to buy these new machines and then once they have them they may start to play games on it too.

4. Initially the temptation to put games out very quickly for the new systems will result in games that look fantastic but perhaps do not play as well as they should. But as developers learn more about the new systems then we'll see some great gameplay - particularly as people realise that it is games with great graphic, sound and gameplay which go on to be the most profitable.





**ASAM AHMAD**  
THQ  
(European PR division)



1. Both Dreamcast and PlayStation 2 are incredible machines. Visually, new consoles are reaching a level of detail and polygon complexity that allow for richer, more diverse games environments. As games become more realistic in this respect, the interactive experience is more immersive and rewarding.

Where these consoles, and newer machines such as X-Box and Dolphin, are taking gaming even further is multiplayer capability. Consoles have always been traditionally 'lounged-based' entertainment machines, and multiplayer used to mean a crowd on your sofa with split-screen. With Internet capabilities through modems, and soon broadband, the gaming arena is about to explode with multiplayer games. The potential to battle hundreds of players simultaneously will be a great leap in the way games are designed as players demand more varied and diverse games to exploit this new community.

2. The PC will always have its place. The beauty of consoles is that the machine has a specific capability and hence when a game is produced, it will play the same way on all machines. This plug 'n' play facet means that consoles are great for the mass market that just want to play the game with as little hassle as possible. Even with newer console features such as email ability, the capability is streamlined for a mass-market audience.

PCs will remain the toys for the big boys, always after the latest hardware and innovation. Aside from the obvious aspect that a PC can be used for just about everything from accounting to word processing, graphics and of course games, the PC will always remain a constant technology leader where consoles are only released every so often when technology has leapt far enough to justify a whole new machine.

3. The biggest area, which is holding back the next generation of games is the archaic technology, used to 'see' games. Consoles and TVs are still 2-D devices. Games these days are held back by simple flat displays, and whilst worlds are created in true 3-D space within a game, they are only ever perceived through the 2-D viewport of a CRT. The next stage must newer visual display technology - holographic TV or 3-D specs. Obviously it will take some time, but it's a real area where games are held back. Once the technology exists, the word 'immersive' will take on a whole new meaning.

4. Gameplay will evolve to redefine how we perceive the 'playing field'. With the growth in multiplayer, games are likely to develop more and more innovative ways to challenge of fellow friend. From puzzle games to outright first-person shooters, multiplayer capacity will be exploited. It will no longer be the case that you are playing your console, more that you use your console to play against another person; the console just becomes nothing more than an instrument to fight your duel, the game being the rule-set.

5. One of our key products for the new generation is to be Summoner, an RPG from Volition. Appearing on PS2, it will be a multiplayer fantasy game. The PS2 allows for stunning visuals which help realise this fantasy world, and allow for larger, more complex worlds. More information can be seen at [www.summoner.com](http://www.summoner.com). For Dreamcast, we have in development Evil Dead: Hail to the King. Being produced in conjunct with our Heavy Iron development team, Evil Dead will feature the star of the films Bruce Campbell and is being worked on in conjunction with the original director of the Evil Dead films, Sam Raimi. Consoles such as DC and PS2 allow for developers to create such highly detailed worlds, and help converge entertainment forms like film to create new, but recognisable, immersive experiences.

6. As I mentioned before, in order to make games more immersive, a technology leap is required to bring true 3-D space to the gamer. Often there is talk about things like neural implants, but the reality of such like is way too far away and potentially controversial to be a reality. I can just see a vision of mentally affected kids overdosed on neural implants to such a degree that they can't think for themselves any more!

VR headset are more likely, and will address the issue of true 3-D, however by their very nature they remove a person from their social surroundings. From an observers point of view, all you would probably see is a mad person with a helmet on, twitching and ducking - something that only the hardcore would really indulge in. I think the reality is going to be more down to Earth. There are so many opportu-

nities to create new games based on community and internet gaming, that this is really where new concepts will be focused - certainly in the short term. These communities allow for gamers to play alter egos in massive online soap operas; from role-playing games to action games, the online world will allow for more diverse experiences. THQ's recent acquisition of Genetic Anomalies, an online gaming technology company, was strategic to ensure that as a company we are there to exploit the brave new internet gaming world.



**DAVE PERRY**  
Shiny Games  
(Perhaps the most respected and famous of all developers. Creator of Earthworm Jim, Messiah and MDK).



1. Dreamcast is kicking butt right now... However it's looking like PlayStation 2 will get the advertising and games they need to pull ahead. That said, the X-BOX demos looked amazing and I am now seeing Microsoft worry Sony and not having to ship a machine for 18 months or so. Dolphin will have Nintendo's great library of designers behind it and RARE. 2001 - 2002 is gonna be a really crazy-ass blood battle of a year.

2. The PC is getting way to expensive to match the new consoles... Try building an X-BOX for a few hundred dollars without Microsoft helping you!

3. Speech control/recognition/communication. (It's getting better day by day).

4. It will generate new kinds of games. It's a completely new tool to play with as a designer.

5. We are working on an action fighting game... It's in pre-pre-pre design... So right now, it's just a bunch of ideas. Our other new game is called Sacrifice, check it out at [www.sacrifice.net](http://www.sacrifice.net).

6. It will radically change over time, real-time photorealism, real anatomical simulations, speech recognition, thought recognition etc. Wherever it goes, you can bet I will be there in my wheelchair.





# of gaming

**DAVID BRABEN**  
Mr. Elite himself.

*Just one piece of news, yes, another Elite is being planned!*



**1.** Dreamcast - It is great to have a new console after so many years. Sadly, there are no really good titles yet (i.e. ones I would personally buy a machine for); at least not that I've seen. Crazy Taxi is quite fun, and Shenmue looks good (but I haven't played it yet as my Japanese is not up to it). It is disappointing that the network support for games has not yet appeared - I think this has disappointed a lot of people, me included. For these reasons I think it may now be overshadowed by PlayStation 2.

PlayStation 2 - I think the jury will be out on this for some time, but I think this is a very impressive machine, despite the fact the launch titles in Japan are a little disappointing (they are still better than those on the Dreamcast, I think). Some of the things I have seen previewed were very good, and the specs are exciting.

X-Box - This is still a way off, and will have a fight to compete with PlayStation 2 which is likely to have been around for a year by the time X-box is released. Nevertheless the announced specs are pretty good. My concern here is whether Microsoft can keep the amount of 'state' in the machine to a minimum. By this I mean issues of different display drivers, OS version etc, and whether the concept of installing a game is going to be used. The reason this is a worry is (as I understand it) the machine has an 8G HD and that is plenty of room to have installed drivers, viruses and other software that might cause a game not to work, and lose much of the advantage of it being a console. Most of the advantages of an HD can be mimicked with a large memory card as on the PlayStation 2, but at least the mem card can be removed easily, and you are back to the 'virgin' machine. Having said that, the X-box is a very exciting machine and will doubtless give Sony a good deal of solid competition.

Dolphin - This is the 'dark horse' of the race. As I understand it, the Dolphin is going to be hard on the heels of the PlayStation 2, outside Japan, at least, but with a higher spec. Historically, Nintendo have had the best games (I think), despite the fact there are far fewer available. Games like Mario 64, Zelda, Goldeneye, and Banjo-Kazooie made the N64 very desirable, so for this reason I think the Dolphin is a serious contender.

**2.** People have been saying the PC is under threat since the early days of the NES. Arguably the consoles have already taken over for certain styles of games, certainly in terms of sales. Different people understand different things when you say 'PC' - some take it to mean the architecture - hence Linux PC, Windows PC etc. Some mean the very idea of having a unit with keyboard & monitor that does not go through the TV (e.g. Macintosh, Amiga), which is what it used to mean. Arguably the X-box is already a spin-off PC designed to sit under the TV, which confuses the issue further.

If the only defining factor of the 'PC' is the presence of a keyboard, then 'PCs' will grow hugely as more and more people want email and web access, and want the ability to type URLs and emails, and ultimately PlayStation 2 etc may be considered as PCs. Fundamentally the PC will carry on changing as it has over the years, and this question will keep being asked.

**3.** Appealing to a wider audience. Games that don't include killing. The current fashion to blame computer games for tragic acts of violence in the US particularly, and the willingness for people to believe this is causing publishers to get very worried. 'Games' like the Sims hint at this already.

**4.** Gameplay will move forwards a good deal. Particularly the increased memory, and on-line possibilities will change what can be done a good deal.

**5.** Another Elite...

**6.** VR headsets are still a way off. Those we have had already were awful to use, and made many people feel sick. Also seeing a kid even further disconnected from the real world may alarm parents. I think the TV screen will be the norm for at least the next few years, but with a move towards more social games and away from single player games.

**RUSSELL RITCHIE**  
Head of Promethians

*Having recently finished Renegade Racers on PC/PSX and Dreamcast - five titles are in development on the aforementioned formats and PS2, including PICASSIO.*



**1.** The Dreamcast is very easy to read and the programmers know its limits. The rest are still being explored. We are expecting a lot from these new consoles and certainly have a lot planned.

**2.** Where it's always been, the expensive but powerful machine, good for real-time, strategy, Role Play Games and for people who want to be cutting edge. The PC is constantly evolving. It may not be up to a new console's standard on the release date but I believe it will always catch up and then overtake as it always has done. The PC will also remain the main tool to go online for sometime.

**3.** We are already working on one of the items that we believe to be the next revolution in game design. This is quite simply co-operative gameplay, one person drives the boat whilst the other skis. This can be seen in our soon to be announced game 'WakeBoarders'.

**4.** Better visuals give a high sense of realism, this in itself will enhance gameplay. However other developing factors will certainly contribute to the evolution of gameplay. For example, more ram, faster processors, a higher level of AI, better testing and advanced physics.

**5.** We are now working on a game designed for the next generation consoles. It's called Picasso. It's a non-violent game opening up a whole new genre. You are a cat-burglar who must infiltrate the biggest art museums from around the world with the most advanced security systems. Use your shadow hologram generator to give the guards the wrong idea of your position clearing the way for you to escape. Consult your digital sound detector to find out exactly what direction those footsteps are coming from. Place micro cameras and whilst in one room, watch what's going on in another. Be stealthy or be caught.

**6.** There's so much going on making predictions is really only useful for generating ideas. Computers already inform every part of our lives. Things like quantum computers, biochips and all that stuff mean that computing power, and miniaturisation, is advancing at a phenomenal rate. Computers are blurring the meaning of reality, the visions of the cyberpunk writers look less fanciful every day. Games developers are always looking forwards, and we are no exception, trying to make tomorrow into today, borrowing, bending and inventing. It's an extraordinary time.

## HERE'S WHAT WE ASKED THEM!

**1.** What are your impressions of the Dreamcast, PlayStation 2 and (from what you know) the X-Box and the Nintendo Dolphin?

**2.** Where does the PC fit into this new oncoming console era?

**3.** When and what do you think will be the next revolution in game design?

**4.** Will all this new hardware result in only a visual improvement to games or will we see gameplay evolve too?

**5.** Tell us about a game (or a game concept) you're working on now for one of the new systems.

**6.** In a nutshell, what do you think the future of Gaming looks like? (VR headsets? Neural implants?) Discuss!

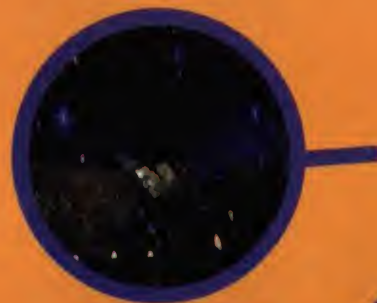



## STEVE DAUTERMAN

Electronic Arts

(Head of the new EA Studios OZ in Queensland, ex-LucasArts honcho)

1. Any new platform is exciting for a developer and both the Dreamcast and PS2 fit that bill. Both are extremely powerful and let us continue to push graphics and gameplay at least in terms of sheer horsepower. At EA we have not been currently doing any Dreamcast development and have been focusing exclusively on the PS2 for the moment. We have a close eye on both the X-Box and the Dolphin. The specs for the X-Box are fantastic (particularly the hard drive) and we are now waiting to see if Microsoft can pull it off from a marketing and distribution side and make it a real competitor.

2. The PC continues to move along. While the game market size is still stagnant on the PC, there are plenty of opportunities for companies to make profitable games for the platform. It is still the only platform that can truly do internet-based gaming. It will be interesting to see how the X-Box will affect the PC market if it becomes a reality since it is basically a stripped down PC anyway. I don't believe the PC will go away by any means, but it will still remain a somewhat niche and hobbyist market. I liken it to people who love to tinker with old cars and love to have the hottest engine in town. That's what the PC market seems to be for the highest end games. Where it will become difficult for PC developers in the future is to try and justify multimillion dollar budgets to produce the quality of productions that we will see on PS2 when the market size for the PC is still much smaller. We are already starting to find that today.

3. When studios and publishers are willing to take some more chances or there is a revolution in the industry like the indie film business in Hollywood. The biggest problem with trying to have anything revolutionary right now is that the risks are way too high financially for publishers and developers to try anything new. It will come from some small game out of nowhere and possibly even through the Internet where someone independently takes a risk. I think the next revolution has to be around the multi-player and internet aspects of gaming when there is real mass market broadband capability.

4. In the first generation of games, I think you will see primarily visual improvement. It won't be until 2-3 years from now that we see any improvements in real gameplay. I have yet to see anything innovative yet out of the current releases. I do think the gameplay can be improved through increased immersion into the worlds in terms of better graphics and AI. I think gameplay is fairly evolved these days and hasn't changed much in the 10 years I've been in the business. It's a matter of improving the environments and the quality of the experience. Frankly, I would like to see games be built tighter and shorter where the average person has the chance to complete a game. I think we have got into the habit of really overbuilding games these days where it is very rare where anyone completes it and sees all the hard work that has gone into making it. It's like making a movie and having everyone walk out in the first 15 minutes.

5. Unfortunately, our studio is just starting up and we are in the early design phases so I can't say anything for now.

6. You probably will wake up searching for this guy named Morpheus while falling into something called the Matrix... nah. Seriously, I think the future of gaming will be the same as it ever has been. It is an activity that can be enjoyed individually against an imaginary opponent that is in the mind of some programmer/designer. Or it is a community/social activity that brings people together for a good time in a competitive or cooperative mode. The hardware will get better, the peripherals more interesting, but the best games will be relatively simple in nature in their ability to immerse people in an environment where they can do things they could have rarely thought of doing in the physical world.



## SIMON JOBLING

Projects Manager at Take2 Games Europe, gives the company's views on the next gen machines and what to get excited about... or not!

1. After a blistering first weekend I believe the outlook for Dreamcast looks tough. Stock problems, software line-up (the old problems) certainly hit the Christmas sales but even if these are put right, the consumer now seems to be focusing on Sony and beyond, so they will need to pull something rather exceptional out of the hat to breathe long-term life back into the proposition. As for Sony, its consumer franchise, its development relationships plus its product quality do suggest it is set to build still further on its success. They need to sort out their teething problems but history suggests they will. Whether they will achieve their 1 in every 2 households goal for PlayStation 2, I don't know, but, as things currently stand they should at least replicate PlayStation's success. Microsoft does represent a new, and potentially the biggest challenge Sony has faced in the Games market. Machine specs look fine, and they have already started their usual spoiling tactics. But you can't ignore a company with all the credentials (and stacks of cash) that Microsoft has. The key weakness is giving Sony at least a year's head start - but if they get all the key stuff sorted, they have got to be a contender.

Nintendo - who knows? I don't think there is room for three major hardware formats, and they seem to be being pushed more and more into the toy category. Still, the success of Pokémon shows they can do some things well and maybe the future for them lies in concentrating on some niches within the overall market.

2. Some would say it is redundant but I think that exaggerates the position. And I think this needs looking at in the context of the position that PC fills in the minds of consumers. The scramble for Internet access means that, as far as the mass market is concerned, PC still has some years left in it. However, WAP and developments in mobile technology plus Broadband development are obvious threats to the role of the PC in consumer's lives but if anyone can accurately forecast all of these I would like to meet them.

3. Pass!

4. Not only the new hardware but the aforementioned mobile technology developments could certainly lead to a different type of game i.e. quiz; fantasy league etc taking hold. But Broadband offers the biggest opportunities, as finally multi player gaming could become a mass-market proposition all around the world.

5. Next!

6. Who knows? But people were demeaning VR headsets six years ago at trade shows and look how many millions of units they have sold! No, what I would say is one of the real changes PlayStation has facilitated is to make gaming a more social past time. I see this continuing and I am not convinced that the mass market, which is where the key battle now is, really want to lock themselves in a virtual world for hours to get their gaming experience. There will always be a hardcore looking for the ultimate experience, but I believe the social interactivity of gaming will continue to increase in importance, and technologies, which enable that, such as Broadband, will be the winners in the mass market.

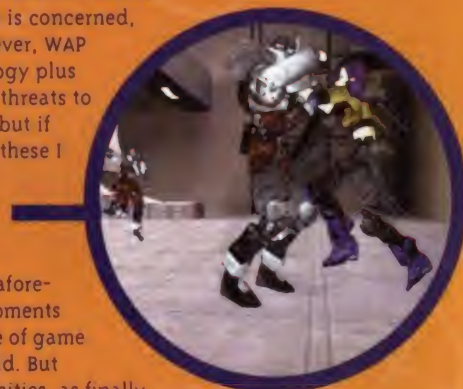



# GET A LIFE!



# GAMESPOT

AU

gaming news • reviews • game guides • competitions  
• gamer forums • hints & tips • game polls  
• free downloads

[www.gamespot.com.au](http://www.gamespot.com.au)

Lara Croft & Tomb Raider 1,2,3, & Tomb Raider - the Last Revelation (c) Core Design.  
Published by Eidos Interactive. All Rights Reserved.



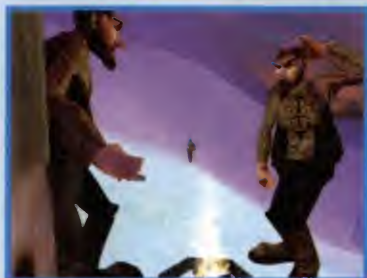

# everquest: ruins of kunark

It's just over a year since EQ made it's name as the greatest online RPG to grace our PCs, and it's perhaps only now that gamers who bought it are finally beginning to pull themselves away from it's evil, social life destroying grip. Unfortunately for those who were on the path to rehabilitation, Verant may have put the final nail in the coffin with their new expansion pack, Ruins of Kunark. Recently the people of Norrath have walked with more zest in their step. Everyone seems more alive and excited with knowledge of the rediscovery of the

ancient land to the south. For with this news is the promise of new adventure and treasures to be had. In fact, Kunark offers around 20 new zones, a new lizardman race to play as (the Iskar), and the ability to reach level 60 as opposed to the maximum of level 50 previously.

### LET ME EXPAND ON THAT...

First off, it must be said that the worst thing about the expansion pack is actually purchasing it! If you choose to order it through Verant, the shipping costs are enormous. It

### Quake Stuff

#### Q3Team Arena

With Quake3: Arena, id were mainly focused toward refining the art of deathmatch. With their new mission pack, Team Arena, the tables have turned because as the title suggests, the emphasis is now all about teamplay.

Currently there are at least 3 game-types planned. From the screenshots it's safe to assume that there's a hybrid CTF game in the works. However we know a little more about the other two game-types. One is called Harvester and involves collecting the heads of your enemies once you frag them. Fans of headhunters will be looking forward to that one. Another game-type is called Overload and it involves destroying a powerful artifact in your enemy's base whilst at the same time defending your own artifact.

To add spice to the matches some pretty cool sounding items and powerups will be available:

**Invulnerability:** When used an impenetrable shield surrounds the player for a short while. You won't be able to run around with it on but you're free to let loose on the



WWW

### Penny Arcade Comics

These guys have come up with some classic gaming related comic strips. Always good for a laugh.

<http://www.penny-arcade.com/>





## net.news

enemy without getting a scratch.

**Kamikaze:** A nuke that will not only obliterate you but anyone within the blast radius. Good to use when you're overwhelmed by the enemy.

**Portable Portals:** Possibly a variation of the Translocator in UT.

**Doubler:** Doubles the damage you can dish out.

**Scout:** Doubles your running speed. Excellent for flag runs.

The mission pack will also introduce three extra weapons. The Chaingun from Q2 and Nailgun from Q1 make a return, and to top it off you'll be able to make a nice little mess with the new Proximity Mine Launcher. Also of note are the new teamplay models and highly customizable HUD in the works. With 12 new maps for gamers to relentlessly frag each other on it looks as if we're in for a gib soaked treat with Team Arena.



worked out to be over 120 dollars AUS to buy the pack in time for Kunark going online on the EQ servers. And even then, most Aussies who ordered it this way got their copies late. Verant did however remove the shipping charges to anyone who didn't get their order on time, but for an expansion pack to cost more than a full game is just ludicrous! Our third world currency is also to blame in this case, but that's another story. Now that RoK is actually in stores here, we are treated to yet another terrible marketing ploy. You cannot buy the expansion pack by itself; instead you must purchase a box that contains both the expansion and the full game together. So basically, if you want to play the expansion you have to buy the full game again too... Laughable stuff.

Ok, so money is no object and you're still interested in what Verant have put together? Well, read on. Thankfully the company's game creating skills far outweigh their marketing ability for RoK is an impressive piece of work. Catching the new ship from the demi-human land of Faydwer to the new continent is the first surefire sign of what Kunark has to offer. The thing is simply so gigantic that it makes the old ships look like rowboats. It's enormous sails fan out like dragon wings to propel the ship at speeds relative to that of a jet, zooming you off into the sunset with great anticipation of what is to come.

### IN THE ZONE

The zones in Kunark are markedly larger and more detailed than what was commonplace in Antonica (the old continent). The most noticeable of the enhancements would have to be the trees. The new land is fortunate enough to actually have wind to blow the tree branches around! It looks lovely too. Apart from that you'll see all manner of statues, old ruins and other landmarks littered throughout the zones making the new environments very pleasant to explore. The price you pay for the cosmetic upgrade is a noticeable increase in system requirements. You may need to turn the resolution down a notch or lower the clipping plane distance or else suffer playing in a slideshow when you come across thick forest. Populating the beautiful new zones are dozens of stunning-looking creatures. Like everything else in the expansion, the new monsters have had greater detail put into them, more polygons and better texturing results in some awe inspiring foes to smite. One great bonus with having the new larger zones is that they really help to disperse the player popula-



tion. It's so nice to not have to bicker with 20 other people over who gets killing rights to creatures in a particular area. Overpopulation was the bane of Everquest and it's lovely to feel like your party is the only one around. Verant have also played their cards right when dealing with camping, another of EQ's major failings. Special boss NPCs who held important items always spawned in the same spots on the old continents. In Kunark, these named NPCs wander around the place and spawn randomly so people can't camp them. In fact there's even a chance that normal 'unnamed' creatures will drop something very nice, so there is always a good prospect of getting some great loot no matter where you go. These factors simply add more excitement to your hunting trips. This is how Everquest should have been like from the start!

### FEELING OLD?

For players who had reached level 50 ages ago and got bored of EQ, the most enticing addition to come with the expansion would have to be the ability to progress to level 60. Upon reaching

**www**  
World Population Counter

This site isn't much to look at, but it's interesting to occasionally check out just how overpopulated the planet is.

<http://www.census.gov/cgi-bin/ipc/popclockw>

Country	Population
China	1,210,000,000
India	850,000,000
USA	270,000,000
Japan	125,000,000
Germany	82,000,000
France	61,000,000
UK	58,000,000
Italy	57,000,000
Spain	41,000,000
Canada	31,000,000
Australia	20,000,000
South Africa	18,000,000
Sweden	8,000,000
Norway	4,000,000
Denmark	4,000,000
Netherlands	16,000,000
Belgium	10,000,000
Switzerland	7,000,000
Austria	8,000,000
Poland	38,000,000
Czech Republic	10,000,000
Slovakia	5,000,000
Hungary	10,000,000
Slovenia	2,000,000
Croatia	4,000,000
Serbia	7,000,000
Bosnia and Herzegovina	4,000,000
Montenegro	1,000,000
Albania	4,000,000
Greece	11,000,000
Turkey	65,000,000
Russia	145,000,000
Ukraine	48,000,000
Belarus	10,000,000
Latvia	2,000,000
Lithuania	3,000,000
Estonia	1,000,000
Finland	5,000,000
Iceland	0,300,000
Portugal	10,000,000
Spain	41,000,000
France	61,000,000
Germany	82,000,000
Italy	57,000,000
UK	58,000,000
USA	270,000,000
Canada	31,000,000
Australia	20,000,000
South Africa	18,000,000
Sweden	8,000,000
Norway	4,000,000
Denmark	4,000,000
Netherlands	16,000,000
Belgium	10,000,000
Switzerland	7,000,000
Austria	8,000,000
Poland	38,000,000
Czech Republic	10,000,000
Slovakia	5,000,000
Hungary	10,000,000
Slovenia	2,000,000
Croatia	4,000,000
Serbia	7,000,000
Bosnia and Herzegovina	4,000,000
Montenegro	1,000,000
Albania	4,000,000
Greece	11,000,000
Turkey	65,000,000
Russia	145,000,000
Ukraine	48,000,000
Belarus	10,000,000
Latvia	2,000,000
Lithuania	3,000,000
Estonia	1,000,000
Finland	5,000,000
Iceland	0,300,000
Portugal	10,000,000





level 51, characters are treated to a new title i.e. Warriors become Champions. Additionally each level after 50 gives you a new set of devastating skills or spells to pick from. These new accessories are quite impressive for most characters. Rogues and Monks get especially cool new moves like 'Assassinate' which obviously kills creatures with a single blow. Sweet! Keep in mind that while there are a few places for new Iskar characters to play, a majority of the lost continent is meant for high level characters so they can get through the last ten levels. Heck, a lot of it actually needs hefty numbers of cooperating high level players to survive... People who are playing EQ for the first time have a very long road ahead of them before they can see a lot of what Kunark has to offer.

Simply put, the new add-on is very nice. We still can't get over how insane it is to make people buy the whole game again to play it... but looking past that, gamers who loved EQ will love Ruins of Kunark. The one thing that certainly hasn't changed however, is the amount of time you'll have to spend playing the game to get anywhere. Be prepared to lose friends, jobs, fail exams and of course never sleep again!

**Plus:** Looks great and adds a lot more to an already excellent game.

**Minus:** Requires a huge amount of spare time to play. Expensive to upgrade.



## net.news

### Unreal Tournament News

#### Anzac Gaming League

The AGL runs competitive online leagues for Unreal Tournament and variety of other games. UT is proving very popular online as is evident when you look at how many clans are vying for top position on the AGL ladder.



<http://www.anzacleague.com/>

#### Innox map pack

Innox, respected mapper for Epic has released a new map pack for UT. These are levels that weren't quite finished in time for the final release of UT, so expect some good quality stuff. There's even a sequel to the popular 'Facing Worlds' CTF map!

<http://www.planetunreal.com/>





## net.news

### MODs

#### Strangelove MOD

This cool mod allows you to ride your redeemer rocket when you fire it! Fortunately you can hop off at any time to avoid being nuked. <http://ofus.com/mods/>

#### Ultima Online

##### Stuff

Ultima Online 2 news and screenshots are starting to find their way onto the net. The biggest news at the moment is the new name for the title... Ultima Worlds Online: Origin. Quite a mouthful eh? Well since the game is being produced by Electronic Arts this time around, calling it 'Origin' will apparently help gamers remember Ultima's roots. To keep up to date with the game's progress, head here.

<http://www.uo2.com/>



# everquest links

The links below will make you an EQ expert in no time...

#### EQ resource sites

These sites cover the everyday goings on in Norrath.  
EQ Vault <http://www.eqvault.com/>  
EQ Stratics <http://eq.stratics.com/>

#### For all your quest and item information as well as anything else EQ...

AllaKhazam's Magical Realm <http://everquest.allakhazam.com/>  
EQlizer <http://gameznet.com/eq>  
Everlore <http://www.everlore.com/>

#### EQ Atlas houses all the zone maps of Norrath you'll need.

EQ Atlas  
<http://www.eqatlas.com/>

#### Aussie/NZ Everquest Guilds

To get anywhere in Everquest you really need to be part of a guild. Australian/NZ guilds exist and are probably your best bet since their players are generally online at similar hours of the day.

#### Southern Legion

The largest Aussie/NZ guild. It is primarily based on the Tribunal server and has around 100 members.

<http://legion.qql.org>

#### War Brigade

<http://brigade.aus-1.au.nu/>

#### Raptors

[http://members.dingoblue.net.au/steve\\_bond/Evermainpage.htm](http://members.dingoblue.net.au/steve_bond/Evermainpage.htm)



#### L33t Sp34k Generator

This site owz joo! Oh God, I can't believe I typed that. Heheh. Well l33t speak, annoying as it is, is very prominent in the gaming scene. This clever little site translates anything you say into 'l33t speak' for you. Hours of fun.

[http://www.geocities.com/mnstr\\_2000/](http://www.geocities.com/mnstr_2000/)

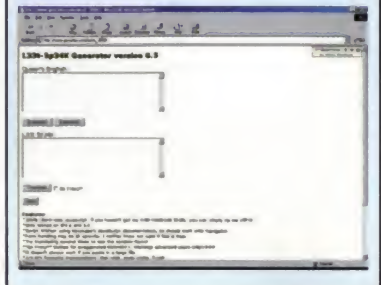



# WINWINWIN COLIN McRAE RALLY 2 for PlayStation!



Entries close July 14th

That crazy scot is back! Ripping through the mud, fishtailing his way through paddocks, grinding apart the gravel, is Colin McRae in his second rally title on PlayStation. We all know how influential the first CMR was, and now number two has found its way into our PlayStations with as much addictive power as the original. If you'd like to win one of five copies we have to give away, then answer the following question:

**Who is Colin McRae's co-driver?**

*Put your response on the back of an envelope with your name and address and post it off to: Rally Cool, Hyper, 78 Renwick St, Redfern, NSW 2016. Vroom and stuff.*



# MOTORCROSS MADNESS 2 for PC and a MICROSOFT FREESTYLE PRO!

Nothing warms the heart more than a well made sequel. Actually, we just made that up, but Motocross Madness 2 is seriously good fun — just read our review on page 68! Launching yourself virtually into space on the back of a Honda just became a possibility. Not only have Microsoft agreed to give away three copies of the game, but we have a Freestyle Pro controller to give away to the first correct entry drawn! Yeah, baby! The Freestyle Pro is an awesome PC gamepad that is motion sensitive for that full immersive experience. It works a treat with Motocross Madness 2.

To win a copy of the game, and be in with a chance to win the Freestyle Pro controller, answer the following question:

**If 95 was before 98, what was before 95?**

*Get it? It's not that hard! Put your answer, along with your name and address on the back of an envelope and post it off to: Microsoft Madness, Hyper, 78 Renwick St, Redfern, NSW 2016. Vroom again and stuff.*



Entries close July 14th





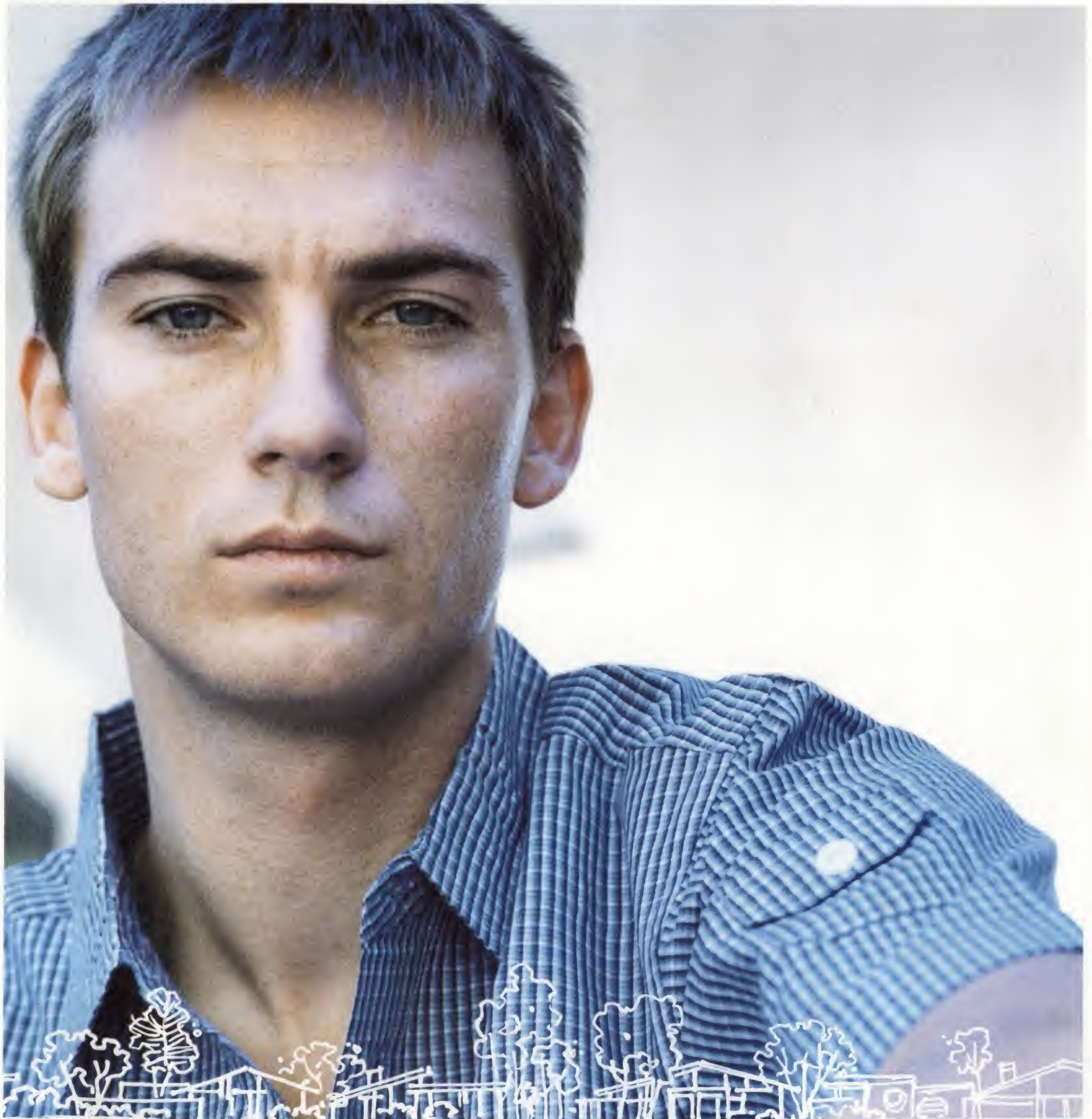

# SUBURBAN®

neighborhood technology clothing brand

400B Smith St  
COLLINGWOOD Victoria  
126 South La Brea Ave  
LOS ANGELES California

DJ Ben Rubin  
Immigrant Records









Noriyoshi Fujiwara. Futsal Player. Nike Holland Game Jersey.  
NIKE0139



# PERFECT DARK



56 »HYPER

Rare keep the Nintendo 64 alive... and how! Read our review of the best Nintendo 64 game ever seen!





## REVIEWS

.....NINTENDO 64.....	
58.....	PERFECT DARK
70.....	EXCITEBIKE 64
.....PC.....	
64.....	DARK REIGN 2
68.....	MOTOCROSS MADNESS 2
72.....	SHOGUN: TOTAL WAR
.....PLAYSTATION.....	
62.....	COLIN MCRAE RALLY 2.0
74.....	TOMBI 2
77.....	N-GEN RACING
78.....	DISCWORLD NOIR
78.....	GEKIDO: URBAN FIGHTERS
78.....	STAR OCEAN: SECOND STORY
.....DREAMCAST.....	
66.....	RESIDENT EVIL: CODE VERONICA
75.....	SWORD OF THE BESERKER
76.....	TIMESTALKERS
.....GAMEBOY.....	
78.....	DRIVER
78.....	LE MANS 24 HOURS
78.....	SPEEDY GONZALES: AZTEC ADVENTURE
78.....	1942



GREEN FOR DREAMCAST  
 YELLOW FOR PC  
 RED FOR NINTENDO 64  
 BLUE FOR PLAYSTATION

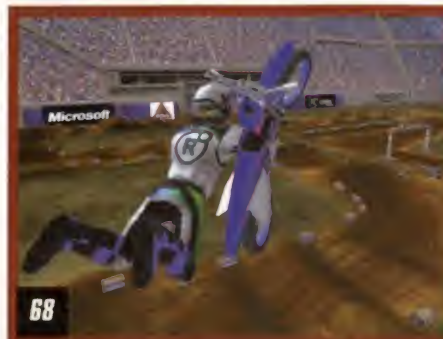

## THE HYPER CREW'S TOP 5

Eliot Fish – Editor

1. Deus Ex – PC  
Simply one of the most addictive PC games in months and months.
2. Colin McRae Rally 2 – PlayStation
3. Motocross Madness 2 – PC
4. Perfect Dark – Nintendo 64
5. Marvel Versus Capcom 2 – Dreamcast

Cam Shea – Deputy Editor

1. Perfect Dark – Nintendo 64  
Four years in the making. Sweet sweet multiplayer action.
2. Code Veronica – Dreamcast
3. Motocross Madness 2 – PC
4. Super Mario World – SNES
5. Mario Kart – SNES

Dan Toose – Reviewer

1. Dark Reign 2 – PC  
Just when I thought I was going to have time to play through Ultima IX... Gee thanks Pandemic.
2. Ultima IX – PC
3. MDK2 – Dreamcast
4. StarLancer – PC
5. Code Veronica – Dreamcast

# HYPERR

All in-house PC previews and reviews are done on Gateway computers.

[www.au.gateway.com](http://www.au.gateway.com)







# PERFECT

**HYP  
ER  
G  
A  
M  
E  
M  
O  
N  
T  
H**







SOMERDOW I THINK THE HEIMLICH MANEUVER IS SAFER



I CAN PIERCE YOUR EAR FROM HERE SUCKER

# DARK

Rare have taken their sweet time 'perfecting' it, but **Roland Flanagan** thanks his gaming gods for their wise decision.



**AVAILABLE:** Now  
**CATEGORY:** 1st person shooter  
**PLAYERS:** 1-4  
**PUBLISHER:** Nintendo  
**PRICE:** \$115 (with RAM pak); \$90 (without)  
**RATING:** M  
**SUPPORTS:** RAM Pak, Rumble Pak & Memory Pak

Only N64 enthusiasts may remember that Goldeneye was one of the most revolutionary first person shooters of the nineties. In a decade that was ruled by tales of doom and earth-shattering quakes, an unassuming N64 title gave Nintendo owners a reason to stand tall. Until Goldeneye arrived, all first person shooters had consisted of mindlessly slaying legions of monsters as you collected keys to open doors. James

Bond's adventure introduced shooting fans to complex mission objectives, the element of stealth and a brilliant console-based deathmatch mode. It's been almost three years since Rare unleashed this masterpiece and it is a testament to their skill that no other console developer has been able to come close to dethroning their game. Perfect Dark has finally arrived in our eager little hands I can tell you that not only does it drastically improve on everything that made Goldeneye great, but it adds so many exciting new modes of gameplay that it absolutely dwarfs the original.

### NEW BEGINNINGS

Some people may be disappointed that the follow-up to Goldeneye is not another James Bond licence. However, Rare should be congratulated for

shedding this restriction and allowing their imaginations to run wild on this epic tale of a sexy secret agent and her harrowing battle against evil, conspiring corporations and the aliens they cohort with.

Taking control of the lethal agent, Joanna Dark, your first mission involves penetrating the DataDyne HQ. Wading through the wake of corpses you leave on your path to the skyscraper's basement involves the same sort of action you're used to in Goldeneye. Admittedly it looks a lot better, but it's not until the second mission that things really crank into gear. Once inside the DataDyne labs your mission to locate and rescue the defecting scientist, Dr. Carol, taxes both your reflexes and your grey matter equally.

People who don't want any of their perfection spoiled should stop read-

ing right now and skip to the heading 'You can open your eyes now' because I'm going to take you on a brief tour of the second level to illustrate the game's style.

Your first mission objective is to locate and photograph an experiment the scientists are performing on some radioactive isotopes. The problem is that once you find the room, walking into it gives Joanna acute radiation poisoning, causing you to walk around with blurry vision for a couple of minutes. Take a quick look through your inventory, however, and you'll find a little spy cam. This device can be remote controlled by you and can safely hover about the room unnoticed and unaffected by the radiation - very cool. A little side note: I was using the camera on a later mission when I made the mistake of leaving it where a soldier





ENJOY KILLING ALL THE MATRIX WANNABES



Unfortunately, we don't have Dr. Daniel and Dr. Carol with us in the villa to discuss matters of moral interest.

## BACK ME UP!

What's the only thing better than a sexy secret agent? Two sexy secret agents. One of the best features of Perfect Dark is the two player co-operative mode. By getting a friend (or the computer) to take control of Joanna's sister, it's possible to play through all the single player missions with two players. While the frame rate does suffer noticeably with all of the game's action being presented in the split screens, there's so much fun to be had going through the main adventure as a team, you'll hardly notice. Put on a really serious military voice and shout commands like "Okay people, we've got to do this by the numbers", "Backup! Backup! I need backup!" or "Cover me, I'm going in" and you'll feel like a hardcore marine. I know I did.

As if the co-operative missions weren't enough fun, Rare have gone and added an ingenious counter-operative mode in which one player controls Joanna Dark, while the second player adopts the persona of one of the enemy guards trying to thwart her mission. If the enemy the second player is controlling is killed by Joanna then they will be transported Matrix-like into another random guard. While this does give the second player an almost limitless amount of players to throw against Joanna, each guard only has a fraction of the life she has - so like Chinese water torture, it's a slow process of erosion. Both of these modes are tremendous fun and we can only hope that other developers will follow Rare's lead.



could see it. He walked up to the camera, tapped it curiously, scratched his head for a second and then levelled his rifle at it and sent it to a fiery grave - ultra cool! Anyway, you're next mission objective is to reprogram the maintenance droids to help you pass through some of the tricky sections of the level. You see, try as I might there was no way I could get past a corridor that was blocked by a series of criss-crossing laser beams. I tried shooting them, I tried distracting them with grenades and I even tried bargaining through them, hoping that Joanna was tougher than they were. No luck. However, after finding a couple of maintenance droids (looking very similar to the little courier droids that Chewie scared the crap out of on the Death Star) I was able to reprogram their paths so that they now patrolled the laser infested corridor, deactivating them as they pass - hurrah! The mission is completed by shutting down the remaining experiments so that their transmissions no longer block your codebreaking gear from unlocking Dr. Carol's cell. Although most of the scientists are pretty co-operative about shutting their experiments down when you shove a machine gun in their face, the last one is a bit of a smart arse and hits the alarm 'accidentally'. As you progress through the game you'll see plenty more example of the enemies exhibiting personality like this.

## YOU CAN OPEN YOUR EYES NOW

Sorry about spoiling a bit of the game like that but I thought it was the best way to give you an idea of the cool sorts of objectives you'll have to complete on each mission. Sure, there's still more than enough death and destruction at the hands of high powered weaponry to keep even the most hardcore Rambo happy, but the mis-

sion objectives keep the action varied and really make you feel like a secret agent. Later objectives that were personal faves include taking a high position over one of the levels and protecting a hostage from execution by taking out her captors and all of the snipers on the surrounding buildings, using the super zoom of your rifle. Another great objective involves knocking out a scientist in the showers and stealing his outfit. Once you're wearing the outfit you can pass by all of the marching gun toting guards without incident, they'll even say hello to you and ask you how you're doing. Oh, how much fun I had exchanging pleasantries with Bob the guard about the good morning he was having, then walking past him, pulling out my silenced pistol and capping him in the back of the head. Oh, and don't get me started about the mission in which you creep around with your night vision goggles after the power has been cut, zooming in on unsuspecting guards with your sniper pistol and making a mess.

Something that is unique to Perfect Dark is that there are often a couple of different ways to complete an objective and if something occurs to you that would work as a solution in real life, then it probably will work in Perfect Dark's world. For example, while infiltrating the famous Area 51 hangar, I was having a huge amount of difficulty getting past one section in the level. There is a big gate that could be opened briefly but the problem was that in the yard behind it there are three sentry guns that cut you to pieces. Running in and taking cover behind some pillars was proving to be almost impossible so I came up with the idea of going back a bit in the level and grabbing a hover bike that was floating around. By pushing this back to the gate, as I suspected, I was able

to jam it between the gate's doors as they were closing so that I could then use the half open gate as cover, taking out the guns with relative ease.

While the game is packed with plenty of cunning levels that will see Joanna through one of the biggest adventures ever, make sure you play the game on at least the medium difficulty level. Playing the game on easy removes the vast majority of the objectives, and presents you with a lot of locked doors and a simple adventure that can be finished in a day. Crank it up to medium and many of the doors will open up and you'll find yourself entwined in a much tougher and more satisfying epic. Notch it up to hard though, and you'll really be in for a challenging treat. Remember that hostage I mentioned that you had to protect with the sniper rifle? Well, on the hard mode, Joanna is disguised as the hostage and must defeat her captors unarmed so that she can grab their guns and take out all of the snipers on the surrounding roofs - very tough!

## IT'S GREAT BEING SINGLE

Even if Perfect Dark only had its single player adventure, it would be the best game on the N64. Thankfully though, Rare has gone crazy with this game's extras. For starters there is the Carrington Institute. This is Joanna's home base and as well as being able to wander around and chat to all your friends, you can earn weapon training medals for every single weapon in the game and compete in a number of combat training missions inside something looking very similar to the holodeck from Star Trek. Tired of being the Lone Ranger during the main adventure? Well, every single mission can be played with a friend either co-operatively or counter-operatively (check out the boxout for all the juicy



You would think this would be where Rare bow out of the N64. But no, we can still look forward to Conker's Bad Fur Day and Dinosaur Planet, both of which were awesome at this year's E3 show.



details). However, it's the deathmatch mode in which Rare have really gone crazy with the options. Not only can you take each other on in the usual one to four player deathmatch, but you can now add in a number of computer simulants (bots) to spice up the action. This means that even if none of your friends are around, you can have a great time challenging up to eight simulants by yourself. And unlike games of Turok: Rage Wars' quality, the simulants in this game have about 20 different personalities to choose from and when cranked up to the highest level, provide an incredibly stiff challenge. While it is possible to still add eight simulants on top of a four player game, the frame rate takes such a hit that you're better off keeping it to a sensible number.

The graphics are probably the least spectacular part of the game. That is not to say that they aren't great, because Rare has made a number of improvements over Goldeneye's (still impressive) graphics engine. However, these modifications are subtle and have taken the backseat to gameplay innovation (not a bad thing when you consider Turok 2's 'nice graphics, shame about the gameplay' approach). The most noticeable improvement would have to be the lighting. While it was possible to shoot out the lights in Goldeneye, it had no effect on the graphics. Shooting out lights can now be used to realistically darken rooms and give you an advantage coming in. The enemy soldiers now sport much more complex animation routines. As well as their standard jumps and rolls to avoid fire, the soldiers will now lie down on the ground and continue firing to make it very difficult for you to hit them. Shoot the gun out of their hands and they will scream, shake their hand, then run to retrieve their

weapons. However, if you spray enough bullets around as they try to grab their weapon, they will decide to leg-it instead. If you shoot them enough times, without killing them, they will actually start limping around in tremendous pain and may even decide to surrender. While I'm on the topic of the enemy soldiers I should mention just how much smarter they have become in this game. In Goldeneye it was a very effective tactic to shoot a few shots into a room to get their attention, then gun them down easily as they ran through the door. Unfortunately, I found out the hard way that the soldiers will now almost never run into a room they know you have covered, and may even decide to retreat and collect reinforcements.

If you've got a surround sound setup at home then get ready to get very happy because Perfect Dark has been encoded in full Dolby. Now you can hear when a soldier is coming up behind you and spin around to face the threat. The gun effects and the explosions are also surprisingly crisp and satisfying when belting out of a powerful stereo. As with the graphics, it's the enemy soldiers that are the

highlight of the sound department. They no longer accept their fate silently. After shooting an enemy you will often hear things like "You bitch!", "Why me?" or "I don't want to die." When the enemy first sees you they will also mutter things like "It's her. Kill her!" or "Target sighted." The comments add to the lengthy dialogue sequences in the cut-scenes and give Perfect Dark a much more absorbing atmosphere.

## PERFECTION

I have heard many people criticise Perfect Dark because the frame rate slows down a bit. However, very few of these people have actually played the game. Had they bothered to get past the N64's dated graphics then they would have found arguably the most enjoyable and addictive console game ever created. Sure the game doesn't have the resolution or frame rate to compete with current PC or DC titles but Rare have provided a game of staggering complexity that offers almost limitless modes of play and I'm not going to do anything but applaud them for pushing the N64 a bit further than it can handle. ■



RARE TOOK OUT THE FACE-MAPPING OPTION, BUT THEY LEFT ANTHON'S FACE IN THERE FOR SOME REASON



## PERFECTION-O-METER



### PLUS

Deep and enjoyable single player missions. Staggering wealth of multiplayer modes (including bot matches).

### MINUS

The frame rate suffers in the split screen modes.

VISUALS	SOUND	GAMEPLAY
93	95	98

OVERALL  
**97**

Perfect Dark is easily the N64's best game, and its only weakness is that the N64 can't keep up with it.





# COLIN MCRAE RALLY 2.0



CMC meets **DMC** in a battle royale on PlayStation...



AVAILABLE: Now  
 CATEGORY: Rally Racing  
 PLAYERS: 1-2  
 PUBLISHER: Codemasters  
 PRICE: \$89.95  
 RATING: G  
 SUPPORTS: Dual Shock

» Rally racing is perhaps motor sport's finest and most dangerous incarnation (just ask the numerous spectators who've been taken out trackside by skidding cars). A stream of games have attempted to bring the near death experience of rallying to our consoles, few with greater success than Colin McRae Rally. The original was a huge seller, with a physics engine and track design of unparalleled excellence, offer-

ing the best rally action available on PlayStation (and perhaps any console).

The art of the sequel is a delicate balancing act, innovating enough to keep the license new and fresh, whilst retaining the elements that made the first game great. By combining the best of the old, with new physics and better graphics, Colin McRae 2.0 has been turbo-charged into a totally absorbing seat of your pants ride of a game.

### EVERYTHING OLD IS NEW AGAIN

The core of the first game was the genuine rally experience, of driving around long muddy tracks in the middle of nowhere, racing against the times of your other opponents. No change here. What has changed though is a brand spanking new physics engine. The game

physics of Colin McRae were second to none, taking the art of the controlled skid to new heights. The best way of describing 2.0 in comparison with the first is more 'floaty'. The cars feel lighter on the track, giving the impression of almost skimming across the surface. This lends itself to some serious edge-of-the-seat-about-to-have-your-brain-smearred-across-the-inside-of-the-windscreen-due-to-impact-with-a-tree hardcore fanging. This is also facilitated by less angular track design, and wider paths. Despite this, there is no less precision required in your driving.

While this may all be a little less realistic than the first game, it plays better and what's more, feels more intuitive. Purists may be a little annoyed, but the adrenalin pumping danger of careen-

ing off the muddy track into oblivion at break neck speed, combined with the near orgasmic bliss of sliding around a good corner with absolutely no traction, should have them quickly shutting their mouths to play some more. Despite the souped up driving model, Colin McRae 2.0 is a no nonsense pedal to the metal racer. Mastering the game still relies upon knowing when to ease back and take your foot off the pedal, letting your car gracefully drift around a particularly tight corner, before slamming it into top gear again. Make no mistake, this is one deep game, and hella tough to master.

One of the great things about the original Colin McRae by comparison with another well known rally game (Sega, I'm looking in your direction),





Colin McRae Rally 2 is coming to the Sega Dreamcast! Eliot had a good rip around some tracks when he was at E3, and it's looking like a very fine version for the Sega system.



was the sheer number of tracks. This was no arcade racer, but a game that took serious dedication to complete. That feat has been replicated here, with tracks from eight countries. The tracks feature different racing surfaces and conditions, including mud, gravel, snow and rain, all of which affect your driving. Also included this time around is a 'race' mode, for those who like to see their opponents, rather than just their times. Options have also been included to overcome flaws in the game design of the original, particularly the ability to select individual stages to practice, a feature the first sorely lacked. You can also select rallies from three countries to begin with, rather than the rather restrictive one that was on offer in the first game.

## NEW-MILLENNIAL MINIMALISM

Taking a leaf out of the oh-so-stylish book of Wip3out, Codemasters have opted for new-millennial minimalist chic in their menu design. Loading times have also improved greatly. The graphics have been tweaked (let's face it, the first game was pretty ugly), although it is still best viewed from a distance. While the cars look good, get up close and the environments start to look like they're made of lego blocks. Worthy of particular mention, however, is the superb sound. The engine grunts and screams like a pig mating with a combine harvester, and the environmental effects, like the sound of mud and gravel thrown up by your tires, are beautiful.

All this said, there are a couple of

downsides to version 2.0. Some wrongs of the past haven't been improved upon. The vocals of co-driver Nicky Grist still appear to have been recorded while smothering him with a pillow. An unfortunate omission is the absence of the driving tutorial. Maybe Codemasters believe (perhaps justifiably) that everyone has played the first game. While you can pick up the skills in game, an easy introduction may have been appreciated by many.

These are merely minor quibbles with a game that excels in every other way. While graphically limited by aging technology, the gameplay feels so damn good that anything beyond the satisfaction of the next skid becomes totally irrelevant. ■



## SCOT-O-METER



## PLUS

Easily accessible, but deep.  
Excellent track design.

## MINUS

It's not on PlayStation 2. Yet.

VISUALS	SOUND	GAMEPLAY
86	89	93

## OVERALL

# 92

The best rallying action in town, bar none.





# DARK REIGN 2

Does Dark Reign 2 deliver the polish that its predecessor lacked? **Dan Toose** believes so...



AVAILABLE:	July
CATEGORY:	Real Time Strategy
PLAYERS:	1-multi
PUBLISHER:	Activision
PRICE:	\$89.95
RATING:	M
REQUIRED:	PII 233MHz, 64MB RAM, 500MB HD space, 3D Accelerator
DESIRED:	PII-300+, 128MB RAM, 32MB 3D Card

Earth, 26th century... The "ruling class" is the JDA (Jovian Detention Authority), a sort of New World Order that was formed in an effort to turn the masses of criminals into useful citizens. The rest of humanity lives outside the JDA's city domes, fending for themselves out in the toxic sprawl... Thus the "Sprawlers". Brute force tends to rule out in the sprawl, so you've essentially got an oppressive police state ver-

sus downtrodden rebels. The game plays out through the last day of Earth's existence, and the power struggles that take place up to that moment for what may lie beyond...

Around two years ago, Activision's real time strategy title Dark Reign had the most flexible RTS engine to date, although the way things panned out, it lacked a little polish next to the other big strategy title of the moment, Total Annihilation. Now we see Pandemic taking the reins, and Dark Reign 2 looks to have the "Wow!" factor that the first title may have lacked, due mostly to its truly amazing visuals.

### UNBELIEVABLY WONDERFUL

Dark Reign 2 features a graphics engine that allow you to not only rotate the viewpoint, but also very simply adjust the angle at which you are looking at the centre of the screen. You can

pop down to ground level, or look down from directly above, almost giving you an old school 2D top-down feel. You can also hold down a key so you can look around freely with the mouse just like in a Quake style game, and you've got the perfect way to view the action. It's not the viewpoints that make the game pretty though, it's the unbelievably wonderful 3D environments and highly detailed unit models that will keep you mesmerised. From a distance, a JDA guardian (basic grunt with rifle) may not look so flash, but zoom down to ground level and get up close, and you can see that the level of detail in the texturing is fantastic, and this goes for every unit in the game. Top this off with excellent animation for both the units, and the marks they leave on the environment, and you have visuals that are hard to complain about.

Pandemic's audio department

should take a bow, because the sound in Dark Reign 2 is really well done in pretty much every aspect. The music drifts between dramatic military themes, through to sleek techno beats, and it's quality all the way. Units give verbal responses to your commands like in any RTS, and each unit type is very distinct, making it easy to know who's buzzing you. There's also a distinct difference in the weapon sound effects, so you can guess what's going on in general just off screen, simply by listening to the gunfire.

Of course, all this audio-visual splendour would count for squat if the game played like a dog, but thankfully, it does not. The interface for Dark Reign 2 features building and squad managers, which allow you to not only to get building and squads to do what you want without looking at them, but also check their "health" at a glance,





! Pandemic were not the folk behind the original Dark Reign — in fact it was Aussie developer, Auran, based in Queensland.



which is very handy with squads. Each button offers a label if you leave the mouse on it, and tech tree requirements pop up too, so you don't need to go reaching for the manual when you first start playing. The only real gripe to be had with the interface is that the minimap is a bit too "mini" for any practical use if you play the game in a decent resolution, and there is no obvious option to configure keys to function the way you want.

### BEAUTY, BUT... BRAINS?

AI is a mixed bag with Dark Reign 2, with "smart targeting" being very handy. This makes a unit attack the most relevant threat by default. It must be said that the pathing could be better though. There were many times I ordered a unit somewhere, and it didn't go in a straight line, even though there were no apparent obsta-

cles in its way. It doesn't always happen, but it's annoying when it does.

That's the only gripe you can have with the way your units behave however, because there's five settings you can quickly apply to either groups or individual units to make them do their job, as you'd like, without having to keep an eye on them. Setting up effective defences is not a chore by any means. One could go into detail about all the units and buildings, but there's little point, as you can really sum it up by saying both sides have a variety of infantry, tanks, artillery, hover vehicles, aircraft, sea vessels, healers, and spy units. There's nothing remarkably inventive or new in this sense, and that's probably Dark Reign 2's only weak spot. Having some units that did something special to the terrain would have been not only nice for variety, but also done

justice by the fantastic visual engine.

There are multiple ways to play multiplayer (king of the hill, etc), and you can play co-operatively, even through the single player campaigns. There's also a map editor, and the ability to record and play back your missions, so all up, there's plenty of gaming here for you, and there's an option for mods, so we can expect some interesting extras in the future no doubt.

Dark Reign 2 is a fantastic transition to 3D for the real time strategy genre. Other titles like Homeworld and Myth have been here before, but Dark Reign 2 is the first of the Red Alert style games to come across. There's plenty here for either a single or multi player enthusiast, and it doesn't require a beefy PC to get a good game on. If you didn't like the first Dark Reign, don't dismiss this as more of the same, as it's a whole new game. ■



### GRUNTRUSH-O-METER



### PLUS

Amazing visuals. Nice interface. Plenty of multiplayer options. Very polished.

### MINUS

Occasional pathing problems. Stock standard units.

VISUALS SOUND GAMEPLAY

96 90 92

### OVERALL

93

Dark Reign 2 sets high standards for the rest of the upcoming 3D RTS games to match. Excellent stuff.

65 »HYPER



"TAKE ROMANTIC WALKS THROUGH THE DOWNTOWN WASTELANDS!"



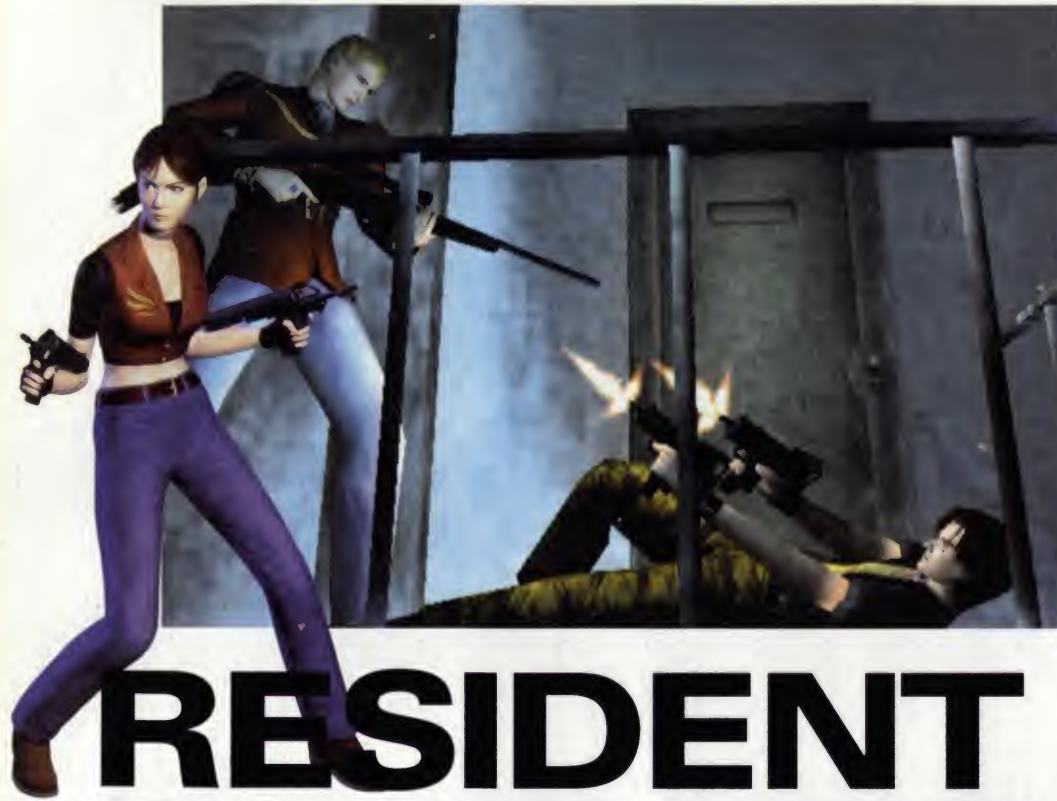

# RESIDENT EVIL CODE VERONICA



Hyper's own Buffy, **Cam Shea**, takes some time out of his vampire slaying schedule to take on some zombies as well...

AVAILABLE:	Now
CATEGORY:	Survival Horror
PLAYERS:	1
PUBLISHER:	Ozisoft
PRICE:	\$89.95
RATING:	M
SUPPORTS:	VMU

With suspense and atmosphere in blood-filled bucketloads, Resident Evil gave us a chance to play out our favourite B-grade horror films, and to revel in the bloodletting. Since then, Capcom have had a field day. Resident Evil 2 was far superior to Resident Evil. The third installment, however, although brilliant, offered little that was new. I think you'd all agree that the original survival horror series needs an injection of fresh blood (pun intended) to recapture the magic of the earlier games... and here it is.

To be blunt, Code Veronica has fried my swizzle stick. This is a master work, and almost everything we were hoping for from a Dreamcast Resident Evil title. It's funny how you can become so blasé about a franchise, and then it's elegantly taken to the next generation and suddenly it all feels fresh again.

### EXPERIMENTAL CRISIS...

Graphically there are very few other games that can compare to Code Veronica. The pre-rendered backgrounds have been relegated to the "too old-skool" bin, replaced by a polygonal world, and how the game benefits! If the camera mechanics in Dino Crisis were the experiment, then Code Veronica is the real deal. Although there are still plenty of fixed angle switches, in Code Veronica the camera is much more versatile — tracking Claire down corridors, panning

around rooms, and zooming in certain situations. Not only does this seem more natural, but it eliminates many of the problems from earlier games — you're far less likely to be bamboozled amidst a horde of zombies by the camera constantly switching angles.

The level of detail and atmosphere in Code Veronica is absolutely sumptuous. The environments look so real you can almost reach out and touch them. A lot of work has gone into this game artistically. It's not just the level of detail, but the number of unique and skillfully textured locations, as well as the sheer flair in the visuals. From the grittiest, grimmest, dankest, most disease infested rooms to the grandeur of a mansion, or the cold reflective metal of an Antarctic base... it's all good, baby.

Special mention must be made of the cutscenes throughout the game. Mostly using the in-game engine, they often

reveal wild plot twists and unexpected situations, and are executed brilliantly. While ogling the level of detail, and the lifelike animations and facial expressions, you'll also be impressed with the direction. Stylish is the only way to describe these cutties, and there are even a number of nods to the Matrix to enjoy.

### SMALL TOUCHES TAKE TWO...

Lighting effects in the game are deft, and used in just the right places to add atmosphere. There are many small graphical touches too, like the camera tracking Claire down an underwater corridor from outside the glass walls, with air bubbles periodically floating up past the camera, and Claire's body wavering slightly through the water. This sequence is literally about ten seconds in the game, and of no consequence, but it's moments like these





## GIBBAGE PATCH KIDS

An element that we feel Capcom should have improved for this title is gibbing. When are we going to be able to blow chunks with the lighter weaponry? I want a visual indicator of how close the zombie is to carking it – "Oh look, I've blown off both his arms, that means one more shot should do it!". Surely this generation of machines would allow for bullet exit points or some Soldier of Fortune style shredding of limbs? After all, if we want to get technical about it, these are decaying zombies we're talking about. Ripping off a zombie arm would be as hard as breaking apart a french loaf, or pulling a party cracker. Ah well, at least we can still revel in explosive weaponry and shotgun headshots.



KEEPING D'BRIEN'S IN BUSINESS

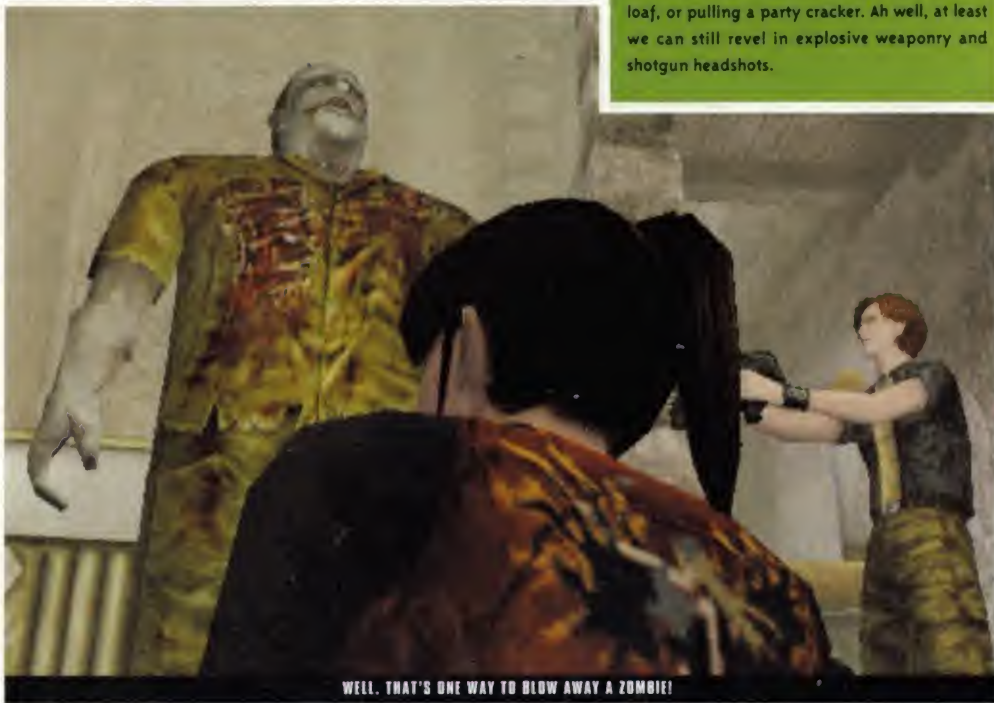

WELL, THAT'S ONE WAY TO BLOW AWAY A ZOMBIE!



WHEN THE UNDEAD PASS GAS, IT AIN'T PRETTY



that make all the difference.

The small graphical details are also complemented by superb positional audio effects. With every door you go through, you're listening out for the sounds that lie beyond it, be it eerie silence, the sound of moaning zombies, or an unknown menace. Regardless, it keeps the atmosphere dripping off the TV screen.

The music is largely a best of Resident Evil megamix, but Capcom have this element so down that keeping familiar themes is fine by us. Capcom also know that less can be more when it comes to scaring people. A few spooky piano notes, or even silence can do more than a fully orchestrated piece. The audio effects also act to compliment the graphics in

remembering certain locations, or finding items.

On the negatives front, the control is still a struggle. I honestly thought that Capcom should have revamped it for Resident Evil 2, but several games later and we're still waiting. RE2 on N64 had the option to switch to a mode where you point where you want to go, so why not implement the same thing here? Indeed, why not allocate a strafe button? Hold it down and you'd be able to keep facing the same way, but you could simply move to the side or back up, without having to turn around. There is a quick 180 turn move, but quite frankly, it's not enough.

This lack of thought on Capcom's part is further compounded by the fact that all the environments are now 3D.

Thus, the camera pans along with you more, instead of just moving from one static spot to another. Thus, there's less danger of the player becoming confused as to which direction to press because of all the camera changes. Resident Evil is all about immersing the player in its terrifying world. Now that the game looks so real, it's a pity that we have to be plucked from our survival horror trance to regularly struggle with the controls. Take note Capcom - bearable shouldn't be good enough.

Despite this, Code Veronica is a phenomenally enjoyable game. An immersive plotline, decent characters and puzzles, mad visuals and sound, an unlockable battle mode, and lots of stuff to shoot. Does it get any better than this? ■



IT'S TIMES LIKE THESE YOU NEED MINTIES



## FRIGHT-O-METER



### PLUS

Oh so good. The definitive RE game...

### MINUS

Storage chests, controls, voice acting cringeworthy in places.

VISUALS SOUND GAMEPLAY

94 91 90

## OVERALL

# 93

Capcom have worked the Dreamcast hard, and created the best Resident Evil game in the series, no question.





# MOTOCROSS MADNESS 2



Cam Shea has always been a BMX bandit at heart... so let's take it up a notch. BAM!



AVAILABLE:	Now
CATEGORY:	Dirt Bike Racing
PLAYERS:	1-Multi
PUBLISHER:	Microsoft
PRICE:	\$89.95
RATING:	G
REQUIRED:	PIII 266, 32MB RAM
DESIRED:	PIII 400, 128MB RAM, 32MB GeForce DDR

» Ahh... the graceful ballet of Motocross racing. The glory of the faceplant from twenty feet up. The perverse beauty of reconstructive surgery. The badge of honour that is breaking both legs and a couple of ribs at once. These are the reasons that I'm not and will never be a crusty demon of dirt... or a dirty demon crust for that matter. It looks like great fun, but goddamn those dudes are crazy. Not to worry, however, as there's always the option of experiencing the thrills and spills of Motocross racing vicariously. Two years ago, to do this you'd probably have to live in a fantasy land, have dressed up in tight leather and attempted to convince colleagues that you need only one more win in the professional scooter circuit to land a sponsorship deal with Yamaha. You'd probably have been labelled mentally unstable, or at least have been ridiculed for living your dream. But then, from out of left field, Microsoft came to the rescue (wow, how often can you say that?). Motocross Madness hit the game

scene, and the world stood still for a while... at least for this reviewer. A brilliant physics engine, a host of very different but equally compelling gameplay modes, and more air than Arthur's bowels, it was a beautifully crafted racer. Thoroughly addictive is really the best way to describe that title, which begs the question - how do we describe this one? The answer is - thoroughly, thoroughly addictive.

## MOTOCROSS MADNESS 101

Let's start with the basics. What has changed for this sequel? Well, there are now two entirely new play modes - Enduro and Pro Circuit. The graphics engine has been substantially upgraded - outdoor environments are far more detailed and a lot larger, and there are now tens of thousands of objects and vegetation in the terrain, as opposed to the bare landscapes of the original. There are also a much wider variety of terrains, and the bikes now handle differently on gravel, dirt, mud and ice. The game physics have been tweaked nicely making massive jumps harder to land than in the original bringing a better balance to the game. The rider animations and collision detection have been improved greatly, as has the opponent AI.

Professional Motocross rider Stephane Roncada has had an active role in ensuring that the game feels just right, as well as in track design. The game now has proper licensed bikes from Honda, Yamaha and KTM,

as well as a range of 125cc - 650cc engines, each with its own unique power curve and handling abilities. Stunts are improved, and multiple stunt bonuses have been introduced. True positional 3D audio has been incorporated, and the sound effects are much more convincing. Finally, the multiplayer component has been expanded and Microsoft will now host a worldwide ranking system and provide online results for every race.

## AMATEUR TREE WEDGING...

With tens of thousands of trees, cactai, hay bales, and berry plantations littering every course, you'll be glad to hear that you can turn the vegetation

collision off. However, you'd be making a mistake if you did. Crazy half luck/half skill runs through light forests and cactus fields are one of the most addictive new features in Motocross Madness 2. And should you run into something, the stacks are spectacular and surprisingly realistic. It's not uncommon to get wedged halfway up a tree, or to launch off a shallow jump straight into a cactus, resulting in a huge thud and your rider catapulting high into the air. Phenomenal stuff.

Motocross Madness 2 is a truly rewarding sequel. In short - you must play this game! Hyper's hallowed Big Rubber Stamp says that you'll love it. ■





! Once you get the game, hop online and download the new terrain editor for track creating mayhem. You'll also be able to grab bike and rider skin templates. The reign of the Hyper bike is nigh... Mua-ha-ha-hah!



## MODE-O-METER

One of the strengths of *Motocross Madness 2* is that there are so many play modes, each with its own learning curve and unique gameplay. For the uninitiated, here's a quick rundown of all the play modes:

**BAJA:** Wide open, massive environments to hoon through. Race the competition through a series of checkpoints. Each terrain has three different sets of checkpoint layouts, plus you can assign any number of random gates to appear — making for essentially unlimited racing.

**NEW! ENDURO:** Similar to Baja racing, but set in slightly more built up environments. From an Arizona trailer park, to an open pit mine, to a deserted Costa Rican airfield, these races are packed full of daring shortcuts through heavily vegetated areas, massive changes in altitude, and obstacles to avoid (or jump over) like tour buses, bulldozers, ski lodges and trains.

**SUPERCROSS:** Indoor courses packed full of bumps, jumps and tight turns. This mode requires great concentration and the ability to use something called "a break pedal". All the courses were designed by Supercross champion Stephane Roncada, and exhibit the kind of lunacy and attention to detail in design that only someone who lives the sport can bring.

**NATIONALS:** Similar to the Supercross, but set in the great outdoors. Nationals has greater changes in altitude, and more varied terrain. A good middle ground between Enduro and Supercross racing.

**STUNT QUARRY:** Bust better tricks than the opposition in a race for points. Just be careful, as Superman Seat Grabs and Nac Nacs can be damaging to your health.

**TAG:** A multiplayer only mode where you must try to be "it" for the longest.

**NEW! PRO CIRCUIT:** The career mode, where you start out as a farm boy racing in a checkered shirt and jeans. The idea being to pull yourself up out of the sticks, drag your leg out of the combine harvester, stop sleeping with your sister, and to make a career racing motorbikes. Starting out against easyish opposition in the Enduro courses, with hard work and dedication you'll earn prize money and sponsorships, and move through the events until you can enter the professional Supercross circuit.



TADDD SOMEROW FOUND HIS WAY INTO THE WRONG GAME



THIS IS WHAT YOU CALL TRAINING



A BRIDGE OVER TROUBLED POLYGONS



## CACTALSPANK-O-METER



### PLUS

So many environments, so many playmodes, such rich gameplay.

### MINUS

Hefty requirements to run the game with the graphics pumping.

VISUALS

93

SOUND

90

GAMEPLAY

92

OVERALL

92

*Motocross Madness 2* improves on every aspect of the original. A must buy title.





# EXCITEBIKE 64

James Ellis gets dirty with Nintendo's latest offering.

AVAILABLE:	Now
CATEGORY:	Motorcross racing
PLAYERS:	1-4
PUBLISHER:	Nintendo
PRICE:	\$99.95
RATING:	G
SUPPORTS:	Mem pak, Expansion pak

There's no doubt that the phrases of the moment are made up of words like PlayStation2, Xbox and millions of polygons per second, but it is important to remember that amongst these visionary technical marvels that lay baking on

the gaming horizon, are games with a more immediate presence. One game that has stirred a slight tress of interest in the gaming community of late is the N64 incarnation of the classic Excitebike. So, is the hype justified, or is it just a bunch of over the hill gamers, reminiscing their romantic retro fantasies? After giving Excitebike 64 the run through, I have a tendency to think it's the latter.

### BUT, IT'S... EXCITING... RIGHT?

Developed by Nintendo and their buddies at Left Field, Excitebike 64 is the most recent motocross game to hit

the system from the current slew. You start off and are greeted with more than the stock standard usual options, with the option to play on special tracks appearing along standard options like season and exhibition racing. These special tracks consist of novelties like a desert race, where one player races through huge sand dunes with other bikes in an attempt to extinguish a series of campfires, the mandatory stunt track as well as other token games like the original excitebike and motocross soccer. This is all good and well to inject some variation in the title, but

who's going to care if the gameplay smells like road-kill Pikachu.

Like the latest all girl pop groups, I've found that most motocross games have a tendency to be dull and uninspiring. Where's the ball breaking excitement associated with the makeshift motocross stadiums packed to the teeth with working class customers, eager to see fate dispense a harsh blow to the groin of some young dirt bike kid? Well Excitebike 64 can claim to be the best motocross game on the system, but realistically that's not saying much. It simply has the best jumps yet.





To see how this sport should really be done, just turn to Motocross Madness 2 for the PC on page 68! Roowwwwrrrrr.



HIDE IT LIKE A HORSE BABY. YOU MIGHT WANT TO WATCH THAT LANDING...

## ...OKAY, A MIXED BAG THEN.

The game engine itself is easy to pick up and start playing, so there are no real hassles when you grab some friends over to play. However, there are enough tricks of the trade to make sure that a learning curve is at least present, so rookies won't be getting continually lucky and humiliating the experienced rider. In fact the fun factor of the game is derived from this learning curve, as you learn how to maximise your jumps, and to navigate multiple mounds. The problem is that along with these good elements the game also has some exasperating factors that may have a few N64 pads broken after each session.

For one, players knock other players off bikes if they clip the opponent's front wheel with their back wheel. Seems simple enough, but you'll find that this is a double edged sword, as it provides unfair protection for the leading bike around bends, where most overtaking is most likely to occur. Not only that but if you are starting off on

a race then the person who is on the same side of the track as the first corner has an instant huge advantage.

The other major downer of this title is the mixed bag of track design. When I've reviewed motocross games in the past, I've always argued that there should be more interesting tracks that are not set in some dirt filled arena. Well Excitebike does take the action outside, but the speed of the game drops remarkably, making the bikes seem as if they are all traveling in first gear. Whilst the outdoor tracks look nice, and have some interesting textures in some places, there is just too much for the N64 to handle.

Graphically the game serves only to enhance the comparison between the N64 and the newer generation machines, with sketchy models and some underwhelming animation. However as with a lot of N64 titles these days the game does include a hi-res option thanks to some expansion pak compatibility, that sets up the screen in

a cinematic or letterbox mode to keep the frame-rate consistent. Although consistent really is all that it is, with the hi-res mode not being able to churn out a race as silky as EA's Supercross 2000's hi-res mode. After experiencing this in a one-player game, I straight away resigned myself against the hi-res mode, and conceded that low-res is what this game should be played in. Still, the two-player mode is quite good on the stadium levels, and there are a lot of courses to be unlocked and stunts to be learnt, leading to a lot of variety in this cart if you can see past the said hindrances. It's too bad, the 3 and 4 player modes couldn't be a bit more playable, but it's the case of Nintendo leaving it all in there and allowing those who aren't put off by dodgy frame rates to have the option, rather than not bothering at all. Overall there is some enjoyment to be had with this title, but it's not terribly addictive nor highly polished, making it a good choice for a rental. ■



## EXCITE-O-METER



### PLUS

Lots of options and variations in gameplay.

### MINUS

Gameplay is a mixed bag of fruity flavours and those "other black ones".

VISUALS	SOUND	GAMEPLAY
60	77	80

## OVERALL

# 77

A soil-filled fling of excitement and frustration.





CAPTURE THE FLAG JUST GOT THAT BIT HARDER

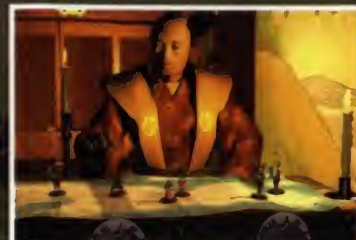

# SHOGUN: TOTAL WAR



With a penchant for samurai-style phat pants, **DMC** was already dressed for total war.



AVAILABLE:	Now
CATEGORY:	Strategy
PLAYERS:	1-8
PUBLISHER:	EA
PRICE:	\$89.95
RATING:	M
REQUIRED:	P200, 32MB RAM
DESIRED:	P350, 64MB RAM, 3D Card

Shogun: Total War drops you straight in the middle of the most violent and turbulent period of Japanese history, where clans continually fought it out for dominance and the title of Shogun. This is a game that conveys the thrill of being a power hungry

warlord on an epic scale, controlling everything from provincial development to the timing of a cavalry charge.

To achieve this feeling of complete control, the game has been divided into two parts. One centers on strategy at a national level, the other allowing you to get down and dirty on the battlefield with a cast of thousands. Like a raisin covered in chocolate, or a monkey in a cowboy suit, Shogun has put two good things together to create something truly sublime.

**CHECKMATE, DAIMYO TRAMPOLINE!!**

The first part of the game is classic

strategy, reminiscent of board games like Diplomacy and Risk. Action takes place on a beautifully rendered map of Japan, divided into a series of provinces. Each province is blessed with certain resources, from rich farmland to gold and silver deposits. As the Daimyo of one of eight clans, you control a number of these, providing you with a certain amount of revenue (Koku).

Koku allows you to develop each province, with buildings from ninja schools and castles, which give you greater military capability, to improved farmland, mines and ports, increasing your revenue. It costs Koku

to build and sustain your units. These include samurai, archers, cavalry, musketeers, warrior monks, and peasant spearmen amongst others. As your troops and generals engage in battle, they develop experience and honour, giving them an edge in future combat.

Gameplay is turn based, rather than realtime, each turn lasting for one season. One unit can be created per turn, and buildings take from 4 to 12 turns to develop. This lends itself to a very strategic form of gameplay, and you'll find yourself spending hours contemplating a single move and the possible reactions of your inscrutable oppo-



HEY CAN'T WE ALL JUST GET ALONG?





THE TOKYO GAME SHOW GETS MORE DANGEROUS EVERY YEAR



nents. Balancing development, military might and your bank account is a difficult and very involving task.

Diplomatic maneuvering plays a large part in this game: Military might on its own will not do. You need to develop the skills of your geishas, diplomats and ninjas, flip sides of the same diplomatic coin in friendly ol' feudal Japan. These can be used to gain information, create alliances, and assassinate enemy generals. Effective use of these is an essential precursor to success on the battlefield, allowing you to estimate and undermine the enemies strength. Be warned though, the clans are all sneaky backstabbing sons-of-bitches who will betray you at the drop of a hat, usually when the odds are most stacked against you. Apart from the backstabbing, other unexpected events, like earthquakes,

plagues and Mongol Raids also affect your game at this level.

The second limb of the game comes into play when the Machiavellian instinct gets the better of you or your opponents, and your armies clash. You can take the easy option, and let the computer resolve the battle automatically, or take command of your forces personally. The incentive to do the latter is that, firstly, it's bloody fun, and secondly, if you hone your skills, victory is far more likely.

### WAR! HUH! GOOD GOD! WHAT IS IT GOOD FOR?

When you accept command of your armies, the game switches to a real time battle mode. While the environs are rendered in 3D, your troops are sprites, which works beautifully (check the screens), allowing your PC to pump out up to 5000 on the battlefield at one time. Yep, this is wargaming on an epic scale.

Each province has a certain battlefield, whose characteristics are determined by the topography. Lowlands afford the best opportunities for large attacking armies, wide-open spaces allowing you to outmaneuver your enemies. Highlands are better for defense, allowing troops to retreat to hilltops and rain arrows upon the slowly advancing enemy. Rivers can pose problems, their single crossing point a death trap for attacking armies.

Battle command is comprehensive, but you get a handle on it quite quickly. Before the battle begins, you deploy your units personally, or automatically arrange them in different ways, including tight, loose, and wedge for-

mations, and emphasizing all out attack, or skirmishing (engaging with the enemy while retreating). These can also be altered on the fly. You can command at the level of the individual unit, groups of units, right up to sending the entire army in at once.

The battle engine is quite complex. Performance is affected by weather (e.g. cavalry will be bogged down by mud), and the environment (more damage is done by charging downhill). Units react to battle conditions individually, getting tired and gaining or losing morale depending upon their own circumstances and your army's overall fortunes. Different troops also have different morale levels: peasant yari ashigari will turn and flee as soon as the going gets tough, while elite veteran cavalry are more likely to stick around.

This is all beautifully packaged in funky Japanese design, accompanied by beautiful FMVs. The battles in particular look amazing, truly conveying the epic nature feudal combat. Tasteful music and fantastic sound effects also compliment the action. Battlefield sound is particularly good: as you sweep the camera over your troops, you hear their footsteps, jangling weapons, and warcries.

Shogun: Total War has been designed along the precepts set down by the great Sun Tzu in his classic 'The Art of War', and comes complete with an extract for your instruction. To win, you can't just play: you must become a Daimyo. So this isn't one for the lighthearted. Shogun is serious gaming. A production of class and depth, and an absolute must for any strategy gamer. ■



**!** If this rocks your boat, then look forward to Kessen on the PlayStation 2 for some more feudal Japanese warfare.



### CALIFORNIA ROLL-O-METER



#### PLUS

Totally involving. Deep, complex, but intuitive gameplay.

#### MINUS

Not to be taken lightly.

VISUALS **90** SOUND **90** GAMEPLAY **93**

### OVERALL

# 92

Totally immerses you in the art of war. Beautiful.







# TOMBI! 2

DMC is the Hyper monkey boy, a living Tombi if you will.

<b>AVAILABLE:</b> Now
<b>CATEGORY:</b> 2D/3D Platformer
<b>PLAYERS:</b> 1
<b>PUBLISHER:</b> Sony
<b>PRICE:</b> \$49.95
<b>RATING:</b> G
<b>SUPPORTS:</b> Dual Shock, Memory Card

Tombi appears to be the result of mad scientists attempting to splice the genes of Tarzan and a troll doll (sick puppies all, those mad scientist types). He's a kind of pink-haired monkey boy, who flies through the air with the greatest of ease (well, he can jump proficiently), and whose language capabilities extend to a few chirruppy noises. As you can gather, Tombi 2 will not find you engaging in debate on the finer points of existentialist metaphysics. But there is plenty of the running, jumping, and collecting objects that makes for good platforming action.

### TAKE ME TO FUNKY TOWN

The game is played in a kind of pseudo-3D, echoing games like *Klonoa: Door to Phantomile*, or *Pandemonium*. The characters are fully polygonal (last time around they were only 2D), and conduct their mad shenanigans around environments that are rendered in three dimensions, but are only interactive in two. This engenders a radically different gameplay to 3D platformers of the Ape Escape variety, harking back to the old school action of 16-bit platformers.

Where it varies, and takes advantage

of the 3D environments, is that arrows appear above your head, indicating when you can take varying branches, and move into the background. While a great idea, this does have its occasional problems, and you'll often accidentally take the wrong path as the camera shifts angles and you not sure quite which way which arrow is pointing. But it does add much greater complexity than if it was straight up 2D. The levels quickly become maze-like layers of intersecting paths that you can follow. The complexity of these layers has been increased over the original, giving the game greater depth.

### PIGS MIGHT FLY, AND SAILORS MIGHT BLUSH...

Gameplay revolves around the traditional running, jumping on bad guys and platforms, and solving simple little puzzles that make up the platforming genre. There are set objectives that you need to complete, in exchange for which you receive 'Adventure Points'.

This allows you to unlock boxes around the world, furthering your adventure. As with any good platformer, there are plenty of levels, and lots of sub-games to keep you entertained (including the ubiquitous mine-cart ride). Unfortunately, some of these are frustratingly difficult, leading to the creative use of language in ways that would make a sailor blush.

Wackiness abounds in both character and level design. The colours are bright and garish, with a cartoony feel. The character design is comical, your main opponents being odd purple pig thingies (there is a strange pig theme running throughout the game actually), and the many friendly characters you run into have not-too-boddy amusing accents.

Hardly a gaming revolution, but if you are looking for well crafted platforming action that combines elements of the old and new schools, Tombi 2 has enough depth and nice design touches to keep you entertained. ■



The developers, Whoopee Camp, should be applauded for bringing us a sequel which doesn't re-hash the first game's gameplay. Tombi 2 has been rebuilt from scratch.



### PIG-O-METER



### PLUS

Quirky design. Lots of tasks to complete.

### MINUS

This is well-trodden gaming ground.

VISUALS	SOUND	GAMEPLAY
84	78	83

### OVERALL

# 84

Weird enough to keep you platforming into the night.



HOOF IT PIG BOY



Sword Of The Berserk is based on the manga "Kenpuu Denki Berserk", serialised in Young Animal magazine. That's why the characters are so good.



YOU WON'T BE NEEDING THIS LEG WILL YOU?



# SWORD OF THE BERSERK

When it's close to deadline, **Eliot Fish** goes into the odd berserker rage...



**AVAILABLE:** Now  
**CATEGORY:** Slash 'em' up  
**PLAYERS:** 1  
**PUBLISHER:** Eidos  
**PRICE:** \$89.95  
**RATING:** M15+  
**SUPPORTS:** Vibration and Memory Unit

Butt-mashing beat 'em ups rarely bother with plot. Usually, the aim of the game is simply to survive or make it to the end of a level to "rescue" some person or thing. It's refreshing then to sit down in front of a game that attempts to provide you with a rich story from the opening sequence. *Sword Of The Berserk* is like watching a polygon-based adventure cartoon more than it is an action game. Unfortunately, that's kind of where the problem lies.

## MEET THE DRAGON SLAYER

Your character, "Guts", is the tall, dark and silent type. That is, until he whips out his 7-foot Dragon Slayer and cleaves everybody in his path into a variety of gibs. Once Guts gets into the "swing" of things, he goes on a bit of an Arnie inspired berserker rampage. The developers, ASCII, obviously wanted the action to be focused around the meaty swordplay of your character.

Your Dragon Slayer dwarfs most of your enemies, and the quantity of blood that splatters around the screen is worthy of any B-grade horror flick. You have a few tasty moves at your disposal, plus a variety of secondary weapons to dispatch your enemies with, but there are some real problems with the core gameplay. For one, most of the environments you have to fight in are too enclosed, and you find your character unable to swing his sword properly without being stunned by clanging it into a wall. It's silly that they give you such a big tasty weapon, and then shove you into tight environments where you aren't given the opportunity to really lash out. There are other weapons, like a wrist-crossbow, throwing daggers and bombs, but these are not only limited in supply, but clumsy to use when you get surrounded by enemies. If the controls were a tad more responsive, maybe it wouldn't be so bad, but the action is really quite lacklustre, and it becomes a bit of an exercise in frustration trying to get your big lug to dispatch his foes with any kind of elegance. There are also problems with the camera position in the environment when you're in "action" mode. The perspective sometimes cuts to an angle that

looks cool but makes fighting extremely tricky – an age-old problem with 3D third-person action titles.

Whilst the gameplay mechanics are bothersome, the actual cut-scenes are really well done. All the characters are quite stylish, the voice acting is good and the story is interesting enough to keep you watching the oodles of cut-scenes. As an animated cartoon on TV, *Sword Of The Berserk* would be quite fun to watch, but it seems they spent too long on the story and left the gameplay sequences for the work experience kid to program. There just isn't enough to do, and when you're left watching cut-scenes for up to ten minutes, you begin to wonder where the game is that you paid for. If you persist, there are some rewards in the form of the Prize Box, which fills with bonus options after you complete sections of the game. You can view the movies, look at character bios, even play against the bosses or select any stage you wish to replay – it's just a shame that the gameplay isn't that fascinating.

There are some real problems with *Sword Of The Berserk*, but it still has a good story, characters you'll care about, and some fun hacking and slashing. Just set your expectations low. ■



## CLOUDSTRIFE-O-METER

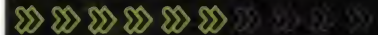

**PLUS**  
 Pretty to look at, and a decent story to follow.

**MINUS**  
 The gameplay is seriously lacking.

**VISUALS** 85    **SOUND** 84    **GAMEPLAY** 67

## OVERALL

71

You may prefer watching the cutscenes to playing the game.





# TIMESTALKERS

Kevin Cheung makes like Doctor Who and goes timestalking...



AVAILABLE:	Now
CATEGORY:	RPG
PLAYERS:	1
PUBLISHER:	Sega
PRICE:	\$89.95
RATING:	G
SUPPORTS:	VMU

Brought to you by Climax Entertainment, who developed Alundra for the PlayStation and Landstalker on the Megadrive, there's no doubting that Timestalkers comes from a family of notable RPG breeding. As only the second RPG to grace the Dreamcast, there is a lot of expectation riding on this game.

Timestalkers initially puts you in control of a young warrior named Sword, who is dragged against his will into a strange land with no apparent escape. With numerous others having been dragged in both before and after him, Sword's quest is to conquer the dungeons in each section of the land in a bid to find a way out. As you move through the game, Sword will encounter other warriors who can join his party.

### IS THIS YOUR FIRST CLIMAX?

Essentially, Timestalkers is a dungeon exploration RPG, largely inspired by games like Chocobo's Mysterious Dungeon and the RPG mode in the Total games. Alundra 2 on PlayStation, also by Climax, is identical. As you travel through the randomly generated dungeons, you can pick up items (which you sell in the town), fight monsters, and eventually defeat a final

boss. Only occasionally will you get a sub-quest, which requires you to do much the same thing anyway.

Every battle is turn-based, where each group of combatants is located on their own grid on the screen. Ergo, good guys in the middle, and several teams of nasties to the left and right of them. At your disposal are different weapon and magical attacks, as well as special abilities like capturing the monsters in a very Pokémon fashion.

If you're familiar with the Climax style, you'll recognise Timestalkers straight away with its vibrant fantasy-based settings, as well as the distinctly elven appearance of the main characters. Beyond that, Timestalkers is a massive disappointment. The entire graphical package could pass off for an N64 game with its static and blurry low-res textures, which isn't helped any further by the fact that the characters are very plain and poorly animated. What's worse is that not a single word is uttered by anyone, drawing

more attention to the poor music and implausible text-based dialogue (ie. badly translated from Japanese).

At the heart of Timestalkers' problems, however, is the fact that the game is easy but time consuming which, without an engaging storyline to speak of, makes the game an exercise in tedium for experienced RPG fans. Fighting with the monsters can almost always be avoided by simply not walking in their vicinity. The story is also poorly thought out. Sword, for instance, is an unwilling hero who complains every time someone asks him for help. Given the uninspiring challenge of the game, it's very easy to agree with him. Finally, there are the randomly generated maps that look bland and monotonous. Climax should have stuck to pre-programmed maps that would've at least had better design and look.

Ultimately, none of the components in Timestalkers have come through to make a solid product. It's the worst RPG on any console since Holy Magic

Century on the N64. But this is no big loss for Dreamcast fans: Evolution is an infinitely superior dungeon exploration RPG and that's also available now. ■



### EXPLORATION-O-METER

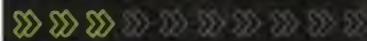

#### PLUS

Magic effects have their moments.

#### MINUS

Shockingly awful dungeon designs. Poorly translated dialogue.

VISUALS	SOUND	GAMEPLAY
70	68	70

### OVERALL

# 68

Of all the obscure Japanese RPGs to pick for local release, this was the most questionable.





Wipeout Fusion on the PlayStation 2 was looking awesome at E3. The solid, photo-realistic tracks and wicked design make this one of the strongest PS2 titles in development.



SAVE YOUR \$79.95 AND PUT IT TOWARDS A DREAMCAST

# N GEN RACING

Arthur Adam takes a look at the next generation and wipes out.



**AVAILABLE:** Now  
**CATEGORY:** Racing  
**PLAYERS:** 1-2  
**PUBLISHER:** Infogrames  
**PRICE:** \$79.95  
**RATING:** G8+  
**SUPPORTS:** Mem card, Dual Shock

Having utilised the office Xerox to duplicate perfect copies of their buttocks, several members of the Wipeout team were given their marching orders. Shortly after, the banished members developed their own racing title, N Gen Racing (Next Generation Racing). Does it replicate gameplay, or is N Gen a fresh new beast?

## IT'S A BIRD, IT'S A PLANE... NO, IT'S A DATSUN!

It isn't difficult seeing certain aspects of NGR that resemble those of the Wipeout games. It's fast, edge-of-the-seat (at times) racing and follows the same pattern of precision competition with a few weapons to boot. That said; don't expect the same adrenalin pumping polish that Wipeout threw at you by the bucket load. There are some imperfections within NGR, which limit it in following its brethren into the realm of classic video games.

Pilfering a few ideas from Gran Turismo, NGR sees you start off with a

wad of money in your pocket. Not having the choice of blowing it on beer and women, you are forced to spend it on a jet plane. Of course, with the measly amount (in jet plane terms), you'll have to purchase something that looks like a Datsun 120Y with wings. Fear not readers, for as you win races you'll build up your kitty enabling you to hop into the seat of some jets with funky, ass-slapping engines.

Initially, I was surprised at how slow the game played. It wasn't a, 'My-God-I-don't-know-how-that-corpse-got-in-my-trunk-officer' kind of surprise, but a surprise nonetheless. You'll be dawdling about the skies like some hippie on loony weed. After being dragged through these tediously tardy races with a 'trainer' jet, the next class of 'fighters' will give you a right kick in the pants. This is where a small aroma of Wipeout leaks through. Zipping about tight corners, picking up boosts that slingshot you along quicker and having a rocket jammed up your tailpipe from the halfwit behind you are all too familiar. But again, even with these resemblances, the makeup of NGR isn't as sophisticated as the aforementioned. Firstly, because you're way up in the air, the scrolling countryside can sometimes seem to crawl along. It's only when you fly close to the ground or in-

between valleys that a true sense of speed is attained.

## QANTAS ISN'T THE ONLY ONE THAT DOESN'T LOOK GOOD AT THE MOMENT...

Quite frankly, the visuals of NGR aren't anything special and some might go as far to say they've taken a serious beating from someone wielding an 'ugly' stick. When close to the ground or mountainside, you'll cop an eyeful of some of the biggest pixels this side of the Atari 2600. Along with this, the racing maps are barren and under detailed, as are the jet planes. There's nothing that leaps out and screams, 'Hey, over here. Look at me!' Give us some detail, something to look at.

On the other hand, there are features in abundance to fiddle with in NGR. You can tweak your plane from the engines to aerodynamics. You can sell and buy planes, shoot a few rockets, earn flying permits, take part in championships, single races and the likes. These features coupled with well-balanced controls, enough types of jets to wipe out the China and groovy 2-million-beats-per-second techno music add some merit to the game. But alas, it's as though we've seen this type of game before. NGR is competent and you'll get something from it if you're into racers, but as a whole it just doesn't manage to excite. ■



## LIKEWOW-O-METER

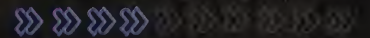

### PLUS

Loads of features and can get fast and furious at times.

### MINUS

Graphically underwhelming and not a 'constant' sense of velocity.

VISUALS **73** SOUND **72** GAMEPLAY **70**

## OVERALL

# 70

They should have called it Star Trek: The Next Generation Racing to sell a few more copies.



## DISCWORLD NOIR

PLAYSTATION

As the title suggests, Discworld Noir delves into the seamy underside of Ankh Morpork, leaving behind the bright cartoony graphics of previous titles as film noir meets Terry Pratchett's brand of satire. Discworld Noir is an absorbing, and at times utterly frustrating game — although it must be said that I wasn't born with what is commonly known as "adventure game fanboy logic". Playing as a private investigator named Lewton,

this is a dark game, full of strange encounters and unexpected plot twists.

Discworld Noir exudes atmosphere. The music is subtle, but enchanting, and the graphics move from one dark film noir location to the next. Unfortunately, the game's low resolution graphics lead to a lack of personality in the characters and settings — they're a poor companion to the dialogue.

The voice acting is of a high standard, although J. Peterman wanna be Lewton takes a while to warm to (ain't that always the way in these gritty tales of crime and hard drinking detectives), and the actor could have injected a little more charisma into the role.

The heart of a good adventure

game, however, is in a good plot, interesting characters and great dialogue, and in these departments Discworld Noir doesn't disappoint. The conversations are true to the wacky sensibility of previous Discworld games, with plenty of puns and sarcastic one liners. Nothing much we haven't heard before, but still good fun. After all, crusty first mates who burst into bouts of existential angst always help make for an interesting game.

Discworld Noir is a must buy for



Terry Pratchett fans, but be prepared for frustration if you don't own a PSX mouse.

CAM SHEA

VISUALS	SOUND	GAMEPLAY	OVERALL
72	85	79	78

<b>i</b> AVAILABLE: Now
CATEGORY: Adventure
PLAYERS: 1
PUBLISHER: GT Interactive
PRICE: \$79.95
RATING: G

## GEKIDO: URBAN FIGHTERS

PLAYSTATION

Gekido is a beat 'em up in the tradition of old scrollers like Streets Of Rage, with the addition of some ambitious fighting game elements and a dash of manga. There is some serious mayhem to be had here, as with a MultiTap, Gekido is one hellishly frantic button mashing exercise. There is a lot of room for improvement though. For starters,

the animation and sound seem very below par. Executing kicks can sometimes slide your character along the ground even if you're not meant to be moving, and if you make contact (which is sometimes very hard to judge) there is a pitiful lack of crunching sound effects. This gives you the impression that you're wandering through the streets laying into bags of wet bread, rather than hard as steel bad guys. There are, however, a tonne of moves to discover, with everything from fighting-game "throws" and combos to special moves for each character. Playing with four friends in Arena Battle can be quite amusing, but the one or two-player Urban Fighters mode

(where you play through with a story, wandering the streets beat 'em up style) is where the attraction of the game really lies. There are some nice moments, but you don't need to know much more than to bash your buttons.

It's not the most polished product, but Gekido has a unique style and some good old mindless action.



FRANK DRY

VISUALS	SOUND	GAMEPLAY	OVERALL
78	60	79	78

<b>i</b> AVAILABLE: Now
CATEGORY: Beat 'Em Up
PLAYERS: 1-4
PUBLISHER: Infogrames
PRICE: \$79.95
RATING: M
SUPPORTS: MultiTap, Dual Shock

## STAR OCEAN: SECOND STORY

PLAYSTATION

The understanding most mainstreamers have of RPGs is a combination of D&D/Ultima and a vague sense of Final Fantasy. The former they are unlikely to ever experience it if they already haven't; and the latter is such cooked up Hollywood fare that they wouldn't know a "real" console RPG if it hit them. Names like Secret of Mana and Wild Arms are completely lost on them. That's where Star Ocean Second

Story comes in, which genuine console RPG fans will flock to in droves; but which will be largely overlooked by the masses whose indifference and ignorance of the genre has been usurping the place of quality RPGs for the last 5 years. No doubt, many of you can hear the bitter "it's about goddamned time" seething through this very text.

Star Ocean is the model of what every "real" console RPG should be. The setting is a mix of your character's high technology with the picturesque natural environment of a far-off world you've been transported to. On top of the expected sub-quests, each individual team member from your group can embark upon an independent mission

of his or her own. This opens the path to around 80 possible endings. Also noteworthy is the unique battle system where you can interchange between real-time and turn-based controls.

Finish that with the some of the most exquisite 2D artwork on the PlayStation, and it's no wonder why Squaresoft of Japan are terrified of any RPG from Enix. Even Final Fantasy IX has changed its release date several times to avoid conflict with the long-delayed Dragon Quest VII. A pity the voice acting is a little grating, but you can't have everything. At \$49.95, this game's a steal.

KEVIN CHEUNG



VISUALS	SOUND	GAMEPLAY	OVERALL
90	83	92	91

<b>i</b> AVAILABLE: Now
CATEGORY: RPG
PLAYERS: 1
PUBLISHER: Enix
PRICE: \$49.95
RATING: G





Floating.Dot - Swiss made

swatch  
**.beat**



## Cyberspace Invader

DATA: identified wrist object  
NAME: Swatch .beat  
MATERIAL: aluminium  
DATA CONTAINED: local time, second time, alarm,  
timer, stopwatch functions, strange animations  
EXTRA DATA: features Internet Time  
ORIGIN: unknown, most probably Switzerland  
RSP \$180.

Available at  
Centrepoint: The Swatch Store, Pitt St Mall (02) 9223 2996.  
Darling Harbour: The Swatch Store,  
Shop 261 Harbourside Shopping Centre (02) 9211 1748.  
And leading Department,  
Jewellery and Duty Free Stores around Australia.

www.swatch.com  
>>>END











Our high-speed cable Internet  
can take you there.

[www.wickedgames](http://www.wickedgames)

Get ready to gun it, because Optus @Home high-speed cable Internet is here. Up to 100 times faster than a 28.8K modem, Optus @Home gives you the latest online games at breakneck speed. Best of all, you get the fastest unlimited Internet access for a flat monthly fee, with intense multiplayer gaming at no extra charge. So check it out right now.

Visit our Web site at [www.optushome.com.au](http://www.optushome.com.au) to sign up today.

**OPTUS @ Home**<sup>™</sup>

**1 800 504 504**



# METAL GEAR

NINTENDO ENTERTAINMENT SYSTEM







## YOU ARE GETTING SLEEPY

These two neat little adventures were primitive, yet fun. Despite the crummy (or is that grainy?) graphics, they are still worth playing today. If nothing else, those who subscribe to the Japanese school of dodgy English translations should get a good belly laugh or eight. You have to fire up your emulator and load your Rom for this one: Snake waits cautiously for the guard to doze off so he can sneak past unscathed. But how can he tell whether the guard is alert or not when he is so miserably devoid of detail? Lucky for Snake the guard is given to talking to himself regardless of his level of consciousness. "I'm getting sleepy..." yells the guard, throwing in the tell tale ellipses, shortly before revealing "I feel asleep!" Marvellous stuff.

I'M GETTING SLEEPY!!



I FEEL ASLEEP!!



The first time I heard the name Metal Gear Solid, I thought the age of cyber erotica was truly upon us. What kind of deluded Japanese mind had concocted such an odd title? Hideo Kojima and his marvellous psyche were mutually responsible for the inception of this strategic action fest with diabolical gameplay. He is the reason I spent four nights straight shunning society, disturbing the neighbours and refusing to brush my teeth. This game was almost addictive enough to warrant a designated area of Kings Cross where people could anonymously play Metal Gear Solid for hours without fear of parental intervention. Unbeknownst to many, this was not Mr. Snake's first pixelated adventure, for the world had been saved twice before...

### IS THAT A SNAKE IN YOUR POCKET OR...?

Solid Snake first slithered from the slimy hollow of Kojima's skull way back in 1987. In the same way Monkey Kong was misconstrued to read Donkey Kong in the West (possibly a myth - Ed), the same silliness has taken place here. Think about it. Solid means hard, and hard means bad. See the connection? It's just a shame there are so many perverts out there willing to make fun of a hero. By the

same token, liquid means water and water is cool (and occasionally riddled with *Cryptosporidium*)... hence your even less tastefully named Liquid Snake. But who cares? When you have an erection fighting an ejaculation, not even Brian Harridean could conceal a smirk.

While his name was ridiculous, his mission was simple. Solid Snake, freshest recruit to the all American task force, Fox Hound, was to infiltrate a heavily fortified South African base with little more than his bare hands, and nine frames of animation. Whilst holidaying in hell, Snake managed to rescue Fox Hounds captured agent, Gray Fox, which he did quite stylishly. Old Gray had been sent in following NATO's discovery of the enormous threat to Yankee domination, Outer Heaven. Apparently somebody had gotten hold of a Beta copy of MechWarrior, and designed a nuclear equipped walking battle tank accordingly. Now most of us would simply like to stomp around in one of those babies during the peak hour traffic on Pitt Street, but Outer Heaven had far more devious plans. As with real life, the source of evil came from but one voracious madman. Plunging his creative will into world domination, Big Boss couldn't be bothered thinking of a decent name for himself and deserved death on this fault

alone. Of course, the fact he was also the head honcho at Fox Hound, responsible for sending the inexperienced Snake in the first place didn't cull any sympathy from our boy either and that's when he got mad. In an attempt to upstage Jesus, Snake saved us all from the terror by killing Big Boss in a fiery display of mass destruction that puts the WTO protests to shame. Outer Heaven burned to the ground, the world was safe and Snake became more heavily decorated than an English Christmas tree...

### BUT WAIT! THERE'S MORE!

But Christmas doesn't last for long (except in Target), and Snake soon hurtled back into action for Metal Gear 2: Solid Snake. Ever the conscientious watchdog, NATO noticed somebody was audacious enough to be building another weapons depot in Zanzibar, central Asia. Evidently they weren't too quick off the mark to quell this one, but who can blame them. After all, Zanzibar comes last in the phone book. A closet masochist, Snake agrees to penetrate the fortress in search of answers, retribution, and a bit of good old fashioned biff. The whole mess involved stolen scientists, oil profits and killing by the truck load. Gamers were pleased. Having remembered to wear his thermal underwear into battle, Big Boss had

survived to perpetuate the series just long enough for the developers to think up a new enemy. Snake was tired, frustrated and just a tad emotional when he found Big Boss to be still very much alive and scheming, so he killed him. Hey, we've all had one of those days.









# POSSESSION IS THE LAW

introducing a frenetically paced, visually stunning action RTS  
from sierra studios and massive entertainment



# GROUND CONTROL

[www.sierrastudios.com](http://www.sierrastudios.com)

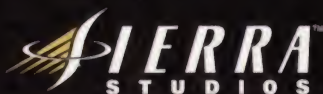

Proudly distributed by  
**dataflow**  
Setting the Standard



# TRIGUN: THE \$60,000,000,000 MAN

**i** CATEGORY: Action, comedy  
 PRODUCTION COMPANY: Victor/Pioneer  
 ANIMATION: 7.5  
 PLOT: 7  
 JAPAN-NESS: Medium  
 OVERALL: 7.5

Somewhere in the distant future, where civilisation is oddly scant and outlaws reign supreme, one man has a \$60,000,000,000 bounty sitting on his head. Known only as Vash the Stampede, or alternatively The Humanoid Typhoon, he is a man most feared for his reputation of levelling entire cities. And in his wake, not a single person has died by his hand. Yet those who've survived a tussle with Vash are left feeling that he is either the greatest hero in the West, or the greatest moron to roam the land.

Sound familiar? It should. Trigun plays on the same

themes of social expectation and perception as the space-roaming classic, The Irresponsible Captain Tylor. The

difference is that Trigun is a marriage of Tylor and concepts from several other popular anime, namely Cowboy Bebop (slick Wild West action), Eatman (philosophical themes), and City Hunter (man going ga-ga over hot babes). The end result is a bizarre and awkwardly paced series. Ironically, it's the variety provided by the awkward pacing that makes you want to wait for the next hilarious scene.

Whilst probably not coming up to the standards of any of the anime it's been inspired from, it still holds its own for being such a unique concept. Trigun is available in VHS and DVD formats.



# GEOBREEDERS

**i** CATEGORY: Adventure, comedy  
 PRODUCTION COMPANY: JVC  
 ANIMATION: 8  
 PLOT: 9  
 JAPAN-NESS: Low  
 OVERALL: 8.5



Now THIS is a breath of fresh air. Electronic phantoms - a result of the digital age - have the ability to meld with any electronic device and control it, and can blend in perfectly with society by morphing into human form. The latest incarnation of these creatures is the phantom cat, and there are hordes of them running amuck all around the world.

Enter Kagura Total Security, a high-tech private security company that has the only known way of wiping out these menaces. The government troops hate

them, the local police hate them - but hey, they get the job done. And it's the technology, technique, and social dynamic of their team that makes them so entertaining to watch. The irony is that the concept behind Geobreeders is almost identical to the Murray/Akroyd classic, Ghostbusters.

Geobreeders is a little rough around the edges, and in some instances it reduces itself to the cliché love comedy that one guy amongst six girls is bound to attract. However, the rest of it is quite entertaining and original; and with a

good dose of slapstick humour and teen titties, Geobreeders is worth hanging around for more.





»»TIM LEVY

**SAMMY USA CORPORATION**

# DEER HUNTING USA

Blasting bad guys to bits may be one thing, as it's usually a case of us (the good guys) or them (the bad guys), but shooting innocent animals for sport doesn't seem to be, well... so sporting really.

On the other hand, the animals who outgrow their natural habitat and threaten the extinction of other life forms ultimately fall into the Bad Guy classification. Although the human animal is responsible for more extinction than any other animal is not the point here. No - in this particular case we are talking about those wily, sleek and slender rusa deer who inhabit Australia's own Royal National Park and are threatening the local wildlife through over eating. See - even cute deer can be evil!!!

Deer Hunting USA is a no nonsense sim which will prepare the human race for the day when the deer (bad guys) are about to take over. Set in the backwoods of Texas, Arkansas, Idaho and Wisconsin, you arm yourself with either shotgun, sniper rifle, bow or musket and accumulate a wall full of hunting trophies. Each weapon has its own characteristics. The sniper rifle has the longest distance, the shotgun has a wider spray of shot, the musket has only one shot, but is the most powerful, while the

bow is the most quiet. I recommend the bow as if you miss a shot, the deer may not scatter as quickly as if you were using a gun.

There are 64 different locations with a great variety of dilemmas to be faced by the modern day hunter. For a start, you can only shoot male deer who are determined by their antlers. Wind direction has to be taken into account as the deer will be able to smell you if they are located downwind of you. Trees, rocks and female deer often obscure your view and more importantly your shots. As soon as the

deer are aware of your presence, they will scatter giving you only a 3-4 seconds to let loose a few shots. Those 125\*kg deer can often take a few shots (depending on where it's hit) before they bite the dust, so missing just one shot can be critical. Failing to down a male or hitting a female will cost you a chance and there are only 3 chances per game.

So even though the game mechanics are fairly basic, it is a challenge to see if you can make it through the various regions on the one credit. And better still, it will help prevent the world from becoming the dreaded (cue spooky music) "Planet of the Deer".



**6.5/10**

**NEO GEO**

# METAL SLUG 3



The rebellion orchestrated by General Morden to set up a cosy little dictatorship for himself was quashed years ago (see Metal Slug 1) by the Peregrine Falcons. He unfortunately escaped detention and attempted another coup, but government forces got wind of the plot beforehand and defeated him with a blitz attack before it could get started (Metal Slug 2).

Presently, there have been some strange goings on (see zombie-ism) at a remote island and both Falcon and Sparrow forces have been recalled to duty to make an assault on what is most likely to be General Morden's new not so secret base.

In a computer game world gone 3D mad, it is a relief to see a return to the basics. Side scrolling shooters are few and far between and when a game is as epic as this one, it is cause for celebration.

What sets the Metal Slug world apart from all the

others is the fantastic comical graphics style, the clever design of the machines and the relentless action. There is also a vast array of weaponry at your disposal including machine guns, rocket launchers, grenades, flame-throwers, shotguns and mortars, as well as the latest additions - the laser and homing missiles. And these are just the hand held weapons. Being able to climb into/onto tanks, submarines (new), jump jets, body armour suits (new), elephants (new), slugnoids and camels makes for great gameplay.

Although there is nothing majorly new to this game apart from a few new weapons and the option of taking different paths, it is still a first-class epic action shooter that is worth pumping in endless amounts of credits to take the game to its completion.

**9/10**







ULTIMATE GAMES HOTLINE

For hot tips and expert technical support call...

## Sega

1902 555 444

Calls charged at a rate of .95¢ per min. A higher rate applies from public and mobile phones.

## Sega PC

1900 142 100

Calls charged at a rate of \$1.50 per min. A higher rate applies from public and mobile phones.

## Roadshow Interactive

1902 962 000

Calls charged at a rate of \$1.00 per min. A higher rate applies from public and mobile phones.

## Microprose

1902 262 667

Calls charged at a rate of \$1.50 per min. A higher rate applies from public and mobile phones.

## Sony Powerline

1902 262 662

Calls charged at a rate of \$1.50 per min. A higher rate applies from public and mobile phones.

## Electronic Arts

1902 261 600

Calls charged at a rate of .95¢ per min. A higher rate applies from public and mobile phones.

## Virgin Interactive

1902 220 058

Calls charged at a rate of .95¢ per min. A higher rate applies from public and mobile phones.

## GT Interactive

1900 957 665

Calls charged at a rate of .95¢ per min. A higher rate applies from public and mobile phones.

## HYDRO THUNDER

NINTENDO 64

### Far East Shortcut

After the Blue Boost that's hanging out in the air, you'll hit a bunch of small waterfalls followed by a tunnel. If you jump on top of the tunnel, you'll cut your time in half for that section.

### Lost Island waterfall secret

Near the beginning of Lost Island you will see a waterfall. You can go through it, taking you through a small tunnel where you can grab a blue boost and a red boost as well as get way ahead of the other boats in the race.

### Venice Canals Shortcut

When you get to the part with the three hard turns in a row (left, right, left) you can skip all of this by jumping over the island in between them both.

### Super Start

Press and hold the A button right after the announcer says "one!" (but before he says "go") and you'll get a "Super Start."

## TONY HAWK SKATEBOARDING

NINTENDO 64

### 10x Trick Multiplier

Hold L at the pause menu and hit: Down, Right, Up, Right, Up, Left, C-Left

### Add Restart Points

Hold L at the pause screen and hit: C-Left, C-Right, C-Down, Up, Down

### Earn all tapes

Hold L at the pause menu and hit: C-Right, Left, Up, C-Up, C-Up, Right, Down, Up

### Fast Motion

Hold L at the pause screen and hit: Right, Up, Down, Down, Up, Down

### Fast Tricks

Hold L at the pause screen and hit: C-Up, Left, C-Down, C-Down, Up, Down, Right

### Get Officer Dick

To unlock the secret character Officer Dick, get all of the tapes with one of the skaters.

### Girl's Picture

Hold L at the pause screen and hit: C-Left, C-Down, C-Right, C-Left, C-Down, C-Right, C-Right

### Perfect Balance

Hold L at the pause screen and hit: C-Up, C-Right, Left, C-Right, Right, Up, Down

### Private Carrera

Start a game in any mode with Officer Dick, pause gameplay, then hold L and press C-Left, C-Down, C-Right, C-Down, Up, Right, Left. Exit the game and return to the character selection screen. Private Carrera will appear in place of Officer Dick. This character has full stats and great specials.

### Slow Motion

Hold L at the pause screen and hit: Down, Down, C-Up, C-Right, Left

## EXCITEBIKE

NINTENDO 64

### Original Excitebike

Successfully complete tutorial mode to unlock the original NES version of Excitebike. Yay!

### Soccer mode

Finish in first place in the silver round of the novice season to unlock soccer mode.

### Hill climb mode

Finish in first place in the gold round of the amateur season to unlock hill climb mode.

### Excite 3D mode

Finish in first place in the challenge round of the pro season to unlock excite 3D mode.

### Cheat Codes

At the main menu, hold L + C-Right + C-Down and press A to display the cheat code screen. Then, enter one of the following codes to activate the corresponding cheat function:  
Stunt bonus - enter "SHOWOFF".  
Invisible riders - enter "INVISRIDER".  
Big Head mode - enter "BLAHBLAH".

## RIDGE RACER 64

NINTENDO 64

### Galaga '88 mini-game

Finish Ridge Racer Extreme Extra in first place to play one level of the classic Galaga '88 game. Destroy all forty aliens to unlock the Galaga '88 car.

### Caddy car

Begin a race on the first track in Grand Prix mode. Then at the start of the race, turn your car directly around and drive into the brick wall until you pass through it. A reversed race should now begin. Win this race to unlock the extremely fast caddy car.

### Blinky ghost car

Drive 99 laps in free run in time attack mode on any track.

### Car preview

At the car selection screen or trophy screen, press C-Up, C-Right, C-Down, or C-Left to change the view and rotate the cars.

### Motion blurring

During an instant replay, press C-Left to add a motion blur effect.

## TACHYON: THE FRINGE

PC

### 5000 Credits

Hit 7 on the NumPad and type: ONE MILLION DOLLARS

### All Cheats

Hit 7 on the NumPad and type: IM A CHEATER

### All Items

Hit 7 on the NumPad and type: BOOM STICK

### All Ships

Hit 7 on the NumPad and type: RAGTAG

### Full Ammo

Hit 7 on the NumPad and type: COME GET SOME

### Full Energy

Hit 7 on the NumPad and type: DILITHIUM

### God Mode

Hit 7 on the NumPad and type: QUICK-ENING

### Instant win by returning to the Starbase

Hit 7 on the NumPad and type: THERE IS NO SPOON

### Upgrade Ship

Hit 7 on the NumPad and type: KESSEL RUN

## URBAN CHAOS

PC

### Dubug mode and Invincibility

During the game press F9 and type "bangunsnotgames" a message will pop up saying debug mode on and giving you invincibility!

### Explosive barrels

When in game put on debug mode and type: R

### Make car appear

When in game put on debug mode and type: E

### Make weapons appear

When in game put on debug mode and



type: F12

## Play as Roper

When in game put on debug mode and type: roper

## Stealth mode

When in game put on debug mode and type: F11

## Win level

When in game put on debug mode and type: win

---

## STARLANCER

PC

### Level Select

To play any mission in the game, at the main menu hold CTRL and type "potatoe". A M will appear in the top left hand corner. Type the number of the mission you wish to play, and then hold CTRL+ENTER to access it.

---

## RAINBOW SIX: ROGUE SPEAR - URBAN OPERATIONS

PC

While playing a game, press [Enter] to display the communication window. Then, enter one of the following codes to activate the corresponding cheat function: Selected character is invincible - avatargod

Team invincible - teamgod

Invisible mode - theshadowknows

Refill ammunition - 5fingerdiscount

Toggle victory conditions - explore

Disable AI - nobrainer

---

## TRIPLE PLAY 2001

PC

### Homerun sounds

While running around the bases after hitting a homerun, press W to hear a soft horn, A to hear a loud horn, or D to hear a whistle.

### Willie McCovey

Hit three consecutive homeruns in season mode to unlock Willie McCovey as a free agent.

### CPU assist

Win a game by ten or more runs in season mode.

### Pencil head

Strike out six consecutive times when batting in season mode.

### Strong arm

Get caught stealing more than twice in one game in season mode.

### Big bat

Hit two consecutive homeruns in season mode.

### Pulsating bat

Score five runs by the same player in one game in season mode.

### Big glove

Make a diving catch in season mode.

### Huge glove

Make two diving catches in one game in season mode.

### Pulsating glove

Make three diving catches in one game in season mode.

### Big baseball

Throw six consecutive strike outs in season mode.

### Huge baseball

Throw nine consecutive strike outs in season mode.

### Flaming baseball

Throw twelve consecutive strike outs in season mode.

### Big League Challenge power boost

Hit ten consecutive homeruns in Big League Challenge mode to get a boost in power, which is noted with a flaming baseball. Hit seven more consecutive homeruns to receive another boost in power, which is noted by a pulsating bat.

### Hidden teams

After you have completed a whole season, playoffs, and win the World Series you will play six extra teams (in order): World All-Stars, Puerto Rican All-Stars, Dominican Republic All-Stars, U.S.A. All-Stars, Legendary All-Stars, and the Triple Play 2001 Dream Team (who have big bats and hit homeruns 95% of the time).

---

## MAX SURFING 2000

PLAYSTATION

### Secret Surfer

When the game is loading, hold R1, R2, right, and Square.

---

## STAR WARS: EPISODE 1 - JEDI POWER BATTLES

PLAYSTATION

### Play as Darth Maul

Successfully complete the game with

Qui-Gon Jinn. Then at the character selection screen, highlight Qui-Gon Jinn and press Select. His picture will replace Qui-Gon Jinn. The version of Darth Maul you will play as is the one you fight on level 5, Tatooine.

### Play as Queen Amidala

Successfully complete the game with Obi-Wan Kenobi. Then at the character selection screen, highlight Obi-Wan Kenobi and press Select. Her picture will replace Obi-Wan Kenobi. She fights with her fists and a laser gun.

### Play as Captain Panaka

Successfully complete the game with Plo Koon. Then at the character selection screen, highlight Plo Koon and press Select. His picture will replace Plo Koon. He fights with his fists and a laser gun.

### Invincibility

At the "Start Up Engine" loading screen, hold L1 + R2 + Select + Triangle.



---

## WWF: SMACKDOWN

PLAYSTATION

### Stevie Richards in Create-A-Superstar mode

Lose to Steve Blackman in July in pre-season mode on the normal difficulty setting.

### The Blue Meanie in Create-A-Superstar mode

Lose to Chyna in July in pre-season mode on the normal difficulty setting.

### Stephanie McMahon in Create-A-Superstar mode

Lose to Triple H at WrestleMania in pre-season mode on the normal difficulty setting.

### Other arena areas

Press Circle (Irish Whip) near the entrance of the center area in "Fall Anywhere" mode to access other areas in the arena

---

## INTERNATIONAL SUPERSTAR SOCCER PRO EVOLUTION

PLAYSTATION

### Old Japan team

Successfully complete the Olympics

with Japan.

### Bonus cup

Successfully complete the game with all the cups.

### Bonus teams

Successfully complete the game with all the league and cups on the hard difficulty setting. Then the European All-Star, World All-Star, Classic European All-Star, and Classic World All-Star teams will be unlocked.

### Bonus stadium

Win the Konami Cup on any difficulty setting to unlock the Clubhouse stadium in exhibition mode.

### Listen to play-by-play commentary in training mode

If you are tired of listening to the always repeated drums in training mode, pause the game. Select "Audio Settings" and turn off the play-by-play option. Resume the game, then pause again. Select "Audio Settings" and turn on play-by-play. Return to the game and you will hear Jonh Kabira (locutor).

---

## BATTLE TANX

PLAYSTATION

### Level select

Enter "BCKDR" as a password.

### All tanks

Enter "THR TN" as a password.

### All weapons

Enter "SRTHMB" as a password.

### Infinite ammunition

Enter "BCKDR" as a password.

### Extra tank bucks

Enter "DPPCKTS" as a password.

### Brandon gang

Enter "SMSLGN" as a password.

---

## NBA SHOOTOUT 2000

PLAYSTATION

### Cheat mode

Pause the game, then hold L2 + R2 + Triangle + Square + X until cheat options are displayed.

### Advanced offense

Special Dribble: Press Triangle.

Back-Down: Hold Triangle.

Pump Fake: Press Circle.

Tip-In: Press Circle.

Follow-Up Dunk: Press Square.

### Advanced dunking

Alley-Oop: Press L1 + X.



# cheat mode

**Normal Dunk:** Press L1 + Triangle.  
**Power Dunk:** Press L1 + Circle (less chance).  
**Finesse Dunk:** Press L1 + Square (hard).

## Advanced dribbling

**Spin:** Press R2 + Triangle.  
**Between Legs:** Press R2 + Circle.  
**Crossover:** Press R2 + X.  
**Behind Back:** Press R2 + Square.

## Advanced defense

**Swipe Steal:** Hold Square.  
**Take A Charge:** Press L1.  
**Intentional Foul:** Press Circle.  
**Cherry Pick:** Press R2.  
**Icon Switch:** Press L2 + Triangle, Circle, X, or Square.

---

## DUNE 2000

### PLAYSTATION

#### Invincibility

During gameplay press Left, Left, Down, R1, R2

#### Lots of Credits

During gameplay press X, X, Circle, Circle, R2, R2, L2

#### Full map

Go to the sidebar and press X when selecting "Square", "Circle", "X", "Triangle", "Triangle", "Square".

---

## ECW Hardcore Revolution

### DREAMCAST

**Wrestle as Joey Styles and Joel Gertner**  
Win the Acclaim belt in career mode.

**Wrestle as Tommy Rich and Cyrus The Virus**  
Win the ECW World TV belt in career mode.

**Wrestle as Taz and Louie Spiccoli**  
Win the ECW World Heavyweight belt in career mode.

#### All Jobbers

Successfully defend the ECW World Heavyweight belt five times in career mode.

#### Wrestle as Beulah McGillicutty and The Sheik

Win the ECW World Tag Team belt in career mode.

#### Wrestle as Bill Alfonso

Successfully complete tournament mode with Rob Van Dam.

#### Wrestle as Judge Jeff Jones

Successfully complete tournament mode with Mike Awesome.

#### Random head mode

Successfully complete tournament mode with Louie Spiccoli.

#### Big head mode

Successfully complete tournament mode with Rhino.

#### Little head mode

Successfully complete tournament mode with Roadkill.

#### Headless mode

Successfully complete tournament mode with Taz.

#### Big hands mode

Successfully complete tournament mode with Jason.

#### Big feet mode

Successfully complete tournament mode with Balls Mahoney.

#### Fat man mode

Successfully complete tournament mode with Spike Dudley.

#### Hangman mode

Successfully complete tournament mode with Sal E. Graziano.

#### Ego mode

Successfully complete tournament mode with Chris Chetti.

#### Custom wrestler textures

Successfully complete tournament mode with Tommy Dreamer.

---

## MDK 2

### DREAMCAST

**Kurt only wearing boxer shorts**  
At the main menu, hold L + R and press X, X, Y, X.

#### Panning camera

Pause the game, then hold L + R and press B, A, B, A.

#### Slow-motion mode

While playing as Max, hold R and press Up, Up, Up, Up.

#### Fart sounds from Doctor Hawkins

While playing as Doctor Hawkins, press L + R + Left + A.

#### Full pause screen

Pause the game and press X + Y.



#### Game music

Play track two and higher of the game disc in an audio CD player to hear music from the game.

#### Hidden artwork and sounds

Place the game disc in a PC compatible CD-ROM drive to find .JPG images, .WAV sounds, and .MP3 blooper tracks from the game in the "mdk2" directory.

---

## SOUTH PARK RALLY

### DREAMCAST

#### Cheat mode

Successfully complete championship mode without using any tokens to unlock all tracks, cars, skins, and other cheat options.

#### Random Checkpoints option

Successfully complete championship mode.

#### Speech Test option

Successfully complete championship mode.

#### Cheat Sheet option

Win the Rally Days 1 race without collecting any pick-ups.

#### All skins

Collect the three hidden pick ups in the Valentine's Day race. The first two are located at each tower. The third is found behind the Skater picture in the jungle.

#### Race as Bebe

Lose the Cowdays race without collecting any health pick-ups.

#### Race as Big Gay Al

Win the Pink Lemonade race.

#### Race as Death

Win the race Halloween race after only dropping off four candies at a time.

#### Race as Grandpa

Win the Halloween race.

#### Race as Ike

Collect the hidden pick-up on top of the airplane in the Memorial Day race.

#### Race as Jesus

Win the Christmas race.

---

## VIGILANTE 8: SECOND OFFENSE

### DREAMCAST

#### Password screen

Enter the options screen, select "Game Status", highlight one of the characters, then press L + R. Remove the VMU(s) from the controller(s) to enable



the codes for one time use.

#### Original Vigilante 8 levels

Enter "OLD\_LEVELS" as a password to unlock all levels from the original Vigilante 8 game.

#### Rapid fire

Enter "RAPID\_FIRE" as a password to remove the delay when shooting weapons.

#### Super missiles

Enter "BLAST\_FIRE" as a password to increase the damage from missiles.

#### Faster cars

Enter "MORE\_SPEED" as a password.

#### Heavier cars

Enter "GO\_RAMMING" as a password to increase your car's weight and ramming ability.

#### Lighter cars

Enter "HI\_CEILING" as a password to decrease your car's weight and hover higher than normal.

#### Fast action

Enter "QUICK\_PLAY" as a password to enable a random fast action arcade feature.

#### Attract enemies

Enter "UNDER\_FIRE" as a password to have three enemies attack simultaneously.

#### Slow-motion mode

Enter "GO\_SLOW\_MO" as a password.

#### No enemies in arcade mode

Enter "HOME\_ALONE" as a password.

#### No gravity

Enter "NO\_GRAVITY" as a password to reduce gravity to the point that your car will almost float when a bump is hit.

#### High suspensions

Enter "JACK\_IT\_UP" as a password.

#### Big wheels

Enter "GO\_MONSTER" as a password.

#### No wheel attachment icons

Enter "DRIVE\_ONLY" as a password to disable wheel attachment icons from spawning.

#### View all ending sequences

Enter "LONG\_MOVIE" as a password to view all endings in one continuous sequence.



# MEGA CHEATS

## PLAYSTATION

- 016 Asteroids
- 017 Auto Destruct
- 018 Azure Dreams
- 019 B Movie
- 020 Battle Arena Tosh 3
- 021 Battle Arena Tosh 2
- 022 Beast Wars
- 023 Bio Freaks
- 024 Blast Clamber
- 025 Blast Radius
- 026 Blastro
- 027 Blood Omen
- 028 Bloody Roar
- 029 Bomberman World
- 030 Brain Dead 13
- 031 Brigandine
- 032 Bubsy 3D
- 033 Bushido Blade 2
- 034 Bust-a-groove
- 035 Bust-a-move 2
- 036 G. Contra Adventure
- 037 Capcom Gen 2
- 038 Capcom Gen 3
- 039 Cardinal Sin
- 040 Cart World Series
- 041 Circuit Breakers
- 042 Code Name Tenka
- 043 Colin McRae Rally
- 044 Colonisation
- 045 Colony Wars
- 046 Colony Wars: Vengeance
- 047 Command and Conquer
- 048 C&C Red Alert
- 049 Contra: Legacy of War
- 050 Cool Boarders 2
- 051 Cool Boarders 3
- 052 Courier Crisis
- 053 Crash Bandicoot
- 054 Crash Bandicoot 2
- 055 Crash Bandicoot 3
- 057 Croc Legend
- 058 Crusader No Remorse
- 059 Cyberstet
- 060 Dark Forces
- 061 Dead or Alive
- 062 Death Trap Dungeon
- 063 Descent
- 064 Defcon 5
- 065 Destruction Derby 2
- 068 Diabla
- 069 Dragon Seeds
- 069 Duke Nukem: Time to Kill
- 070 Duke Nukem: Meltedown
- 071 Dynamic Boxing
- 072 Elemental Gearbox
- 073 ESPN Extreme Games
- 074 Everybody's Gold
- 075 FIFA 98
- 076 FIFA 99
- 077 Fighting Force
- 078 Fighting Illusion: K1-Rev
- 079 Final Doom
- 080 Final Fantasy 7
- 081 Formula 1 97
- 082 Formula 1 98
- 083 Formula Karts
- 084 Forsaken
- 085 Frenzy
- 086 Future Cop LAPD
- 087 G Barius
- 088 G Police
- 089 Gex: Enter the Gecko
- 090 Ghost in the Shell
- 091 Gran Turismo
- 092 Grand Tour Racing
- 094 Guilty Gear
- 095 Heart of Darkness
- 096 Hot Shots Gold
- 097 L.S. Soccer Pro 98
- 098 Independence Day
- 099 Indy 500
- 100 J. McGrath Super x 98
- 102 Judge Dredd
- 103 K-1 Arena Fighters
- 104 Karoro Deception
- 105 Klona
- 106 Knockout Kings

- 107 Krazy Ivan
- 108 Kula World
- 109 Libero Grande
- 110 M.K. 4
- 111 M.K. Mythologies
- 112 M.K. Trilogies
- 113 Madden NFL 99
- 114 Madden NFL 98
- 115 Mass Destruction
- 116 Max Force
- 117 MDK
- 118 Medevil
- 119 Megaman Legends
- 120 Marvel Vs Street Fighter
- 121 Metal Gear Solid
- 122 Metal Slug
- 123 Micro Machines V3
- 124 Monster Trucks
- 125 Moto Racer
- 126 Moto Racer 2
- 127 Moterhead
- 129 N2O - Nitrous Oxide
- 130 Nascar 98
- 132 NBA Live 98
- 133 NBS Live 99
- 134 NBA Shoot Out 98
- 135 Need for Speed 2
- 136 Need for Speed 3
- 137 NFL Blitz
- 138 NFL Gameday
- 139 NHL 98
- 140 NHL 99
- 141 NHL Face Off 98
- 142 NHL Powerplay
- 143 Ninja: Shadows
- 144 Nuclear Strike
- 145 O.D.T.
- 146 Oddworld: Abe's Exodus
- 147 Oddworld: Abe's Odd
- 148 One
- 149 Pandemonium
- 150 Pandemonium 2
- 151 Parasite Eve
- 152 Parappa the Rapper
- 153 Pit Fall 3d
- 154 Pocket Fighter
- 155 Porche Challenge
- 156 Poy Poy
- 157 Psybadeck
- 159 R-Types
- 160 Rally Cross
- 161 Rally Cross 2
- 166 Releaded
- 168 Resident Evil: DC
- 169 Ridge Racer Rev
- 170 Rival Schools
- 171 Riven: Sequel to Myst
- 172 Road Rash 3d
- 173 Rouge Trip: 2012
- 174 Running Wild
- 175 Scars
- 176 Shadow Master
- 177 Shane Warne Cricket
- 178 Side Pocket
- 179 Sim City 2000
- 180 Skull Monkeys
- 181 Small Soldiers
- 182 Smash Court 2
- 183 Soul Blade
- 184 Soviet Strike
- 185 Spice World
- 186 Spyro the Dragon
- 187 Star Wars: Master of Ter.
- 188 Steel Rain
- 189 Street Fighter Alpha 3
- 190 Street Fighter Coil 2
- 191 Street Fighter X+Alpha
- 192 Street Racer
- 194 Tekken 2
- 195 Tekken 3
- 196 Ten Pin Alley
- 197 Technu
- 198 Test Drive 4
- 199 Test Drive 5
- 200 Test Drive Off Road
- 201 Test Drive Off Road 2
- 202 Tetris Plus

- 203 The Fifth Element
- 204 The Lost World
- 205 The Unholy War
- 206 Theme Hospital
- 207 Theme Park
- 208 Thrill Kill
- 209 Thunder Force 5
- 210 Tiger Woods 99
- 211 Time Crisis
- 212 Tobal 2
- 213 Toca Touring Car
- 214 Toca Touring Car 2
- 215 Tokyo Highway Battle
- 216 Tomb Raider
- 217 Tomb Raider 2
- 218 Tomb Raider 3
- 219 Tomba
- 220 T.Makinen World Rally
- 221 Treasures of the Deep
- 222 Triple Play 98
- 223 Triply Play 99
- 224 Twisted Metal 2
- 225 Twisted Metal 3
- 226 V-Rally
- 227 V's
- 228 Vigilante 8
- 229 VMX Racing
- 230 VR Powerboat Racing
- 231 War Games: Defcom 1
- 232 Warcraft 2
- 233 Warhammer
- 243 WCW Nitro
- 235 WCW/NWO Thunder
- 236 WCW V's The World 6
- 238 Wild Arms
- 239 Wipeout 2097
- 240 WWF in you House
- 241 WWF War Zone
- 242 Xena: Warrior Princess
- 324 Need for Speed: High Stakes
- 325 Rollcage
- 326 Rampage 2: Universal
- 327 Contender
- 328 Gex3: Deep cover
- 329 Max Power Racing
- 331 Chocobo Racing
- 332 Dead in the Water
- 333 Fisherman's Bait
- 334 Syphon Filter
- 335 Rugrats: Search Reapair
- 336 Bloody Roar 2
- 337 Silent Hill
- 339 Street Sk8er
- 340 Legend
- 341 Destrega
- 340 Military Madness
- 344 Eliminator
- 400 Wipeout 3
- 402 Dino Crisis
- 408 Tarzan
- 410 Jet Moto 3
- 410 Grand Theft Auto
- 419 Quake 2
- 420 Crash Team Racing
- 421 Mission Impossible
- 422 Nascar 2000
- 423 Ready to Rumble
- 424 Resident Evil
- 425 Army Men: Air Attack
- 426 Wu-Tang: Shaolin Style
- 427 Spyro2: Ripto's Rage
- 428 Vigilante 8: 2nd Offense
- 429 Tomorrow Never Dies
- 430 Supercross 2000
- 431 Medal of Honor
- 432 Jurassic Park: Warpath
- 433 Test Drive 6
- 434 Tom Raider: Last Rel
- 431 Street Fighter EX2 Plus
- 432 Lego Racer
- 433 40 Winks
- 434 Knockout Kings 2000
- 434 Fighting Force 2
- 434 NBA Live 2000
- 439 Sled Storm
- 439 Twisted Metal 2
- 481 Cool Boarders 4

## NINTENDO 64

- 245 Aerogauge
- 246 Allstar Baseball 99
- 247 Aero Fighter Assault
- 248 Automobili Lamborghini
- 249 Banjo Kazooie
- 250 Bio Freaks
- 251 Body Harvest
- 252 Bomberman 64
- 253 Bomberman Hero
- 254 Bockbumble
- 255 Bust-a-move
- 256 Chameleon Twist
- 257 Chopper Attack
- 258 Clay Fighter G3 1/3
- 260 Dark Ritt
- 261 Diddy Kong Racing
- 262 Doom 64
- 265 Extreme G2
- 266 F-Zero X
- 267 F1 Pole Position
- 268 F1 World Grand Prix
- 269 FIFA 98
- 270 Madden 64
- 271 Forsaken
- 273 Goldeneye
- 274 Hexen
- 275 I.S. Soccer 64
- 276 V-Rally
- 277 Juggi's Reckin Ball
- 278 Fighters Destruction
- 279 Madden 99
- 280 Mario Kart 64
- 282 M.K.4
- 283 M.K. Mythology's
- 284 M.K. Trilogy
- 286 Nagano Win Olympics
- 287 Nascar 99
- 288 NBA Hangtime
- 289 NBA in the Zone
- 290 NFL Qback 99
- 291 NHL Breakaway 98
- 292 NHL Breakaway 99
- 293 NHL 99
- 294 Nightmare Creatures
- 295 Offroad Challenge
- 296 Quake 64
- 299 Robotron X
- 300 S.C.A.R.S.
- 306 Star Wars: Shadows
- 309 Top Gear Overdrive
- 310 Top Gear Rally
- 311 Turok
- 312 Turok 2
- 314 Wayne Gretski 3d 98
- 315 WCW/NWO Revenge
- 345 Mario Party
- 348 Vigilante 8
- 347 Glover
- 348 NBA Live 99
- 350 Rush 2: Extreme Racing USA
- 351 Castlemania
- 352 Battle tanx
- 373 Fighting Force 64
- 374 WWF: Attitude
- 378 Star wars: Rogue Squadron
- 377 World Driver Championship
- 378 Super Smash Brothers
- 379 Superman
- 380 Quake 2
- 381 Infisherman - BH 64
- 382 All Star Baseball 99
- 383 Mario Gold
- 384 Monster Truck Madness
- 400 Road Rash 64
- 407 Duke Nuke:Zero Hour
- 410 WCW Mayhem
- 411 Gauntlet Legends
- 434 Rainbow 6
- 435 Monopoly
- 436 Supercross 2000
- 437 Turok Rage Wars
- 442 Gex3 Deep Undercover
- 443 Resident Evil 2
- 444 Nascar 2000
- 445 Battletanx Global Assault
- 446 Hot Wheels: Turbo Racing
- 447 Knockout Kings 2000

## DREAMCAST

- 319 Godzilla Generation
- 320 Pen Pen Tri-iceton
- 321 7th Cross
- 322 Sonic Adventure
- 323 Virtua Fighter 3TB
- 353 A-Life
- 354 Aero Dancing
- 355 Blue Stinger
- 356 Daytona USA 2
- 357 Evolution
- 358 Get Bass
- 359 House of the Dead 2
- 360 Marvel V's Capcom
- 361 Physics Force 2012
- 362 Power Stone
- 363 Puyo Puyo 4
- 364 Sega Rally 2
- 365 Super speed Racer
- 367 Air Force Delta
- 388 Buggy Meat
- 389 Soul Caliber
- 390 King of Fighters Dream Match 99

## NEW PSX

- 462 Rainbow 6
- 473 Thrasher: Skate & Dest.
- 474 Gran Turismo 2
- 475 Dukes of Hazzard
- 476 FIFA 2000
- 478 WWF Smackdown
- 479 Marvel VsCapcom: Clas
- 480 Killer Loop
- 480 KKND Krossfire
- 491 Sout Park Rally
- 490 Worm Armgeddon
- 492 Die Hard Trilogy 2 Las Vegas
- 493 Fear Effect
- 494 Tiny Tank: Up You Arsenal
- 495 Army Men: Sarge's Heroe'
- 496 Syphon Filter 2
- 497 Medevil
- 498 Strett Sk8er 2
- 499 Ace Combat 3: Electrosphere
- 500 Gauntlet Legends

## NEW N64

- 448 Jet Force Gemini
- 485 Xena: Talisman of Fire
- 466 Gauntlet Legends
- 467 Harvest Moon
- 471 Armories: Project Swarm
- 481 Toy Story 2
- 483 Castlemania Legacy
- 484 WWF Wrestlemania
- 485 Mario Party 2
- 486 Command and Conquer
- 487 Earthworm Jim 3d

\* \$1.95 Per Min  
Higher rate from  
Mobiles and  
Public Phones



# Eliot's **EE** diary

**DAY ONE**



**DAY 1 - 9:00 AM**

Here we are on the floor. Oh god. Where to start?



**DAY 1 - 10:30 AM**

The Sega Booth. It Rocked. Look, it's the Dreamcast Mouse!



**DAY 1 - 12:42PM**

It's only Day 1 and already the Booth Babes™ are bored.



**DAY 1 - 1:12PM**

Look! It's Will Wright, bearded creator of the Sims hanging with me like I'm his good buddy!



**DAY 1 - 2:20PM**

Okay, will the real Lara please stand up?



**DAY 1 - 3:15PM**

Hey You, Pikachu!



**DAY 1 - 4:11PM**

Ulala! Sega were jiggy like you wouldn't believe.



**DAY 1 - 5PM**

My eyes hurt, I can barely make out Wipeout Fusion!



**DAY 1 - 6:20PM**

More famous people. Here's Chris Roberts the creator of Freelancer, hanging tough at the Microsoft booth.

**DAY TWO**



**DAY 2 - 7AM**

Oh my God! These Americans are crazy I tell you!



**DAY 2 - 9:25AM**

Nintendo were in their own little world. Dinosaur Planet was gorgeous.



**Day 2 - 9:40AM**

Conker you bad chipmunk! You needed i.d. to get into the adults only Conker bar.



**DAY 2 - 10:20AM**

Microsoft in all their X-Box glory! And there's the actual unit, which is still supposedly only a mock up design.



# incoming mail



**DAY 2 - 11:12AM**  
Gary Coleman!  
"Whatcha talkin' bout everyone?!"



**DAY 2 - 1PM**  
The PS2 shows off its DVD features. They were pushing this HARD.



**DAY 2 - 2:22PM**  
Some dudes going off on the ramps. Tony Hawk and Matt Hoffman were hanging around too.



**DAY 2 - 3:05PM**  
Return to Castle Wolfenstein drew a steady horde. Let me see you bastards!



**DAY 2 - 4:34PM**  
Sushi at the Microsoft booth after seeing the awesome games they had on display.



**DAY 2 - 5PM**  
Happy gamers bash their thumbs around.



**DAY 2 - 5:55PM**  
Just enough time to catch some Zelda Game Boy action. If only I could read Japanese.



**DAY 2 - 6:30PM**  
Man, this is exhausting. "collapses"



**DAY three**

**DAY 3 - 8:30AM**  
Hey, where are those photos I took of the KISS midgets?!



**DAY 3 - 9:02AM**  
"Hi Cam! How's the magazine going? Cam? Cam? Are you there?"



**DAY 3 - 9:34AM**  
The Activision, Eidos, and Blizzard booths were packed for 3 days solid!



**DAY 3 - 10:04AM**  
These guys have something other than games on their minds.



**DAY 3 - 12PM**  
The PlayStation 2 booth still pumping out the polygons.



**DAY 3 - 1:15PM**  
The SquareSoft booth had people entranced with The Bouncer. One of the tastiest PS2 games on display.



**DAY 3 - 2:30PM**  
The Dreamcast had many innovative titles - like Samba De Amigo for one! Who ever thought there would be a maraca sim?



**DAY 3 - 3:13PM**  
Where's Buffy when you need her? Yikes!



**DAY 3 - 3:29PM**  
Peter Molyneux gives the floor a demonstration of Black & White on PC. What a legend.



**DAY 3 - 4:00PM**  
Show over folks. See you next year!



## HYPER LETTERS

78 Renwick St.  
Redfern, NSW 2016  
Fax: (02) 9281 6188  
E-mail: freakscene@next.com.au

### DOOM 2000?

Hello Mr Fish,  
Yess, nice Fish! Good work on the great magazine. Oh yes, precious. Nice Hyperses. I have some questions for nice Hyperses.  
1) In your recent interview with id Software they said that if they made Doom 2000 it would sell a billion copies. Well why DON'T they make another Doom game then?  
2) Why do games run at 60fps when the human eye can't see anywhere near that much? What's the point?  
3) What happens when you review a game? Do you take it home, finish it, then write a review at the office? Or what?  
4) Is working for Hyper a full time job or more some extras money on the side?  
5) I have always been wondering, is it illegal to lend games to friends?  
6) In RA: Aftermath, one of the mission briefings says "The Soviet tank's are protected...". A company as large as Westwood should not be allowed to make spelling mistakes should they? Thankyou nice Hyperses for answering poor Smeagol's questions. Oh yes nice Fish, precious. Nice Fishhhh....

### SMEAGOL

Dear...er... Smeagol,  
1) Probably because John Romero doesn't work at id software anymore, and he created Doom with those guys. Chances are they also think it would be boring to revisit.  
2) Well... have you seen a game running at 60fps next to a game running at 40fps? There's an obvious visual

difference. 60fps is also just an average, as it drops below that depending on the environment. Higher is "always" better. There are so many factors involved aside from just frame-rate.  
3) Yeah, most of our game playing is spent on our own time. That's time we don't get paid for. So you can imagine this is a pretty time consuming job! We usually play at home, then write the reviews up here at the office, but our reviewers do almost everything from home. Sometimes it depends on the game. I actually played Deus Ex here at the office, because I couldn't stop playing it!  
4) Oh, it's full time most certainly. Do you know how hard it is keeping up with what's happening on ALL platforms? Argh.  
5) Of course not! Only if they make copies...  
6) Well, sometimes these things happen. Especially when you're working to tight deadlines, as game developers are. Strange it didn't get picked up in playtesting though. Maybe the tester was distracted by the awesome gameplay (not).

### HOW SWEET

Hyper,  
Why is it that everytime I close my eyes, I see death?  
From Zeke  
  
Dear Zeke,  
Sounds like it sucks to be you.



### GAMES N' GOBLINS

Hyper guys,  
Questions. Me ask. You answer... now.  
1) When will Jedi Power Battles be released on Dreamcast and when it is out do you think the improved graphics will take out the problems with the badly drawn polygons and unfair deaths you mentioned in your PSX review of the game?  
2) Will Sega bring their absolutely mind boggling arcade game "Star Wars Trilogy" to Dreamcast? This game is too cool to have to stop playing to get more change.  
3) As a rather massive Metal Gear Solid fan I must demand that: "anything you got on MGS2 gimme, gimme GIMME!!!! I must know!"  
4) Tony Hawk coming to Dreamcast - When can I expect to be able to get my hands on it?  
5) I'm a huge Evil Dead fan... when will Hail To The King be out and are there any other versions for consoles or PC planned for the game? (I love the fact that you let readers know that Ash was the original badass not Duke, since I've had to argue with dumbasses for years who thought Ash stole his lines from Duke).  
6) I recently saw a game at the arcades called "OutTrigger" I think it was a Sega game, if I am correct, will it be coming to Dreamcast because it would be an absolutely fantastic multiplayer console game.  
7) Finally, are there any games (current or planned) for Dreamcast that resemble MGS and Syphon Filter besides Soul Reaver? I've a hankering for spy-stealthy-watch-out-for-that-guy-then-kill-him type action. That's all from me. (Thank God I hear you say).

### BAR A.K.A "THE ASSGOBLIN"

Dear Bar,  
How the hell did you get the name "AssGoblin"?  
1) It's out in the US sometime quite soon, and we'll be certainly interested to see if they fixed the glitches. I'm sure it'll look lovely.  
2) We can only hope so! There was nothing at E3 though, and they didn't even have the Star Wars: Racer arcade machine there.  
3) MGS2 questions to all the "effects of the digitization of society." Check our E3 preview for more.  
4) A solid local release date has not been set yet, but it's awesome.  
5) Evil Dead is another title still in development, so no date is set as of yet. I've heard that it should be on Dreamcast and PC also!  
6) OutTrigger was shown at E3 on the

Dreamcast and it was awesome fun! Can't wait!  
7) Plenty of great titles are on the way... Half Life, D2 and Ill Bleed should meet your requirements.

### CONFUSED?

Dear Hyper,  
I am confused about a few of the upcoming consoles and their capabilities and I was wondering if you could clear things up.  
1) Which of the following capabilities does the PlayStation 2 really have. DVD, Internet, and can you still play old PSX games on it?  
2) Will Nintendo's Dolphin project be 128 bit or better?  
3) When will Final Fantasy 9,10 and 11 be coming out and will they be on PS2?  
4) Finally, how much will it cost and when will it be released in Australia?

### BLAKE HEARD

Dear Blake,  
Roll about in this informative goodness!  
1) The PS2 is fully DVD, so you can literally put a DVD movie in the drive and watch it, as well as play games. There is no internal modem, but an ethernet port for future broadband capabilities. What this means, is that you will eventually be able to connect your PS2 to the internet via cable technology for blisteringly fast access. There may be a modem add-on sold seperately until that time. The PS2 is also full backwards compatible, so yes, you can put your old PlayStation games in it and play them. Some will even look better.  
2) The Dolphin will undoubtedly be 128 bit, but Nintendo haven't confirmed the exact specs.  
3) Final Fantasy IX will be on the PlayStation by the end of the year. FF X and FF XI will be for the PlayStation 2, but FF XI is a multiplayer online title only.  
4) The PS2 will probably be around \$599 at launch here in Australia, but it's still not official.

### MUSH

Dear Redfernian Editorial Mush,  
Hello. I am keen on getting a Dreamcast and supporting the mighty legends at Sega but I need these questions answered first or I'll staple Barbara Streisand's man boobs to your chins!  
1) Any idea when they are going to lower the price to something cheaper than a used car?

Our witty winning response this month comes from David Yeshouroun via email. Thanks David, it was a nice change from the endless captions about farting.



JEFF PLANS TO CLEVERLY BLOCK THE ATTACK WITH HIS FACE.





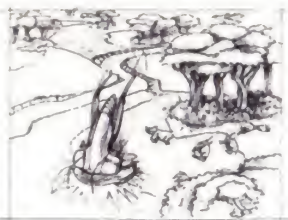

2) Are you people at Next going to make an official or unofficial Dreamcast magazine?  
 3) Is there such a thing as 'Bleemcast'?  
 4) Are the following games coming to DC? Half Life, Daytona 2, Jurassic Park: Lost World, Halo and C&C Tiberian Sun?  
 From a long-time reader and subscriber,

#### A.K.A CHEAP WHORE.

P.S. Eliot, are you really the lord of seafood? (send me lobsters dag namit!)  
 P.P.S. I know who should star in the Tomb Raider movie, Calista Flockhart (with dyed hair, fake tan and 947kgs of titty!)

*Hello you Cheap Whore, Yes, I am the Lord of Seafood and don't you forget it. Calista better than Angelina as Lara? No way!*  
 1) Expect a Dreamcast price drop around the time the PS2 launches.  
 2) If I told you, I'd only be guessing.  
 3) Yes there is! Bleemcast allows you to play PlayStation games on your Dreamcast! Read our news section.  
 4) Half Life, yes. The others have not currently been announced. We can only pray that Lost World is somehow forgotten.

#### ANTI-ALIASING EXPLAINED!

Look. I like Sony, I have every intention of buying their next console. You could say I go for them too. However, I don't like Sony's position in the next generation of consoles. If you guys haven't already heard, ALL the PlayStation 2 games had aliasing problems! What went wrong there? Sony really should have thought about this issue. There has not been one game released that doesn't have the problem. HOW long will this last? I read that it was because of the programming tools. Because Sony haven't got hardware designed for Windows (direct X) their first generation games aren't really a very good representation of how the games

will be like (unlike the Dreamcast). Other people however, say that it will be permanent. What do you guys think? Having read the PS2 import reviews, over the net, I realise also, that Sony REALLY need a ground breaking PlayStation 2 only game (one that will silence the critics). I was interested in what you guys at Hyper think about these things.

#### BAKIO

*BaKio, It's true that the PS2 games we've seen so far suffer from "jaggies", that is, the shimmering and jagged lines in the graphics which are caused by a lack of "anti-aliasing". Anti-Aliasing refers to a technique in which curved lines are given a smoother, rounded more realistic edge. The lines are originally drawn with square pixels which result in a blocky, jagged line, so anti-aliasing fills in the colour between these blocks, thus giving the illusion that there is a curve where there is not. The Dreamcast has full screen anti-aliasing, which is why some of the games on that system have lovely sharp, rounded graphics - no shimmering or jaggies. Hopefully Sony will set out to provide developers with the tools to fix this current hiccup in the quality of PS2 game graphics. We know first hand that companies like Oddworld Inhabitants aren't very happy with the way their games are looking on the console in comparison with other hardware available. PS2 should have had this feature in the hardware from day one - it is disapointing, seeing as it's pretty standard in most PC graphics cards. It can be visually annoying, but it shouldn't affect the quality of the gameplay... still... there should be some pretty ground-breaking PS2 games in the works... we'll see.*

#### SUCKING UP

Dear Hyper,  
 Your mag rules. But enough of that sucking up. I was wondering what console I should buy out of the next generation machines. I like platformers and racing games and they have to be good ones. Also I was wondering if those rumours about the Dolphin not surfacing until late 2001 are true because I really like Nintendo even if Mario looks a little bit funny. Also, have you seen any more reports about the X-Box? It looks very cool on paper. I was also wondering if you have had any reports on Sonic Adventure 2, as I like the sound of it. If it's good it may convince me to buy a Dreamcast. Will there be any platformers for the PlayStation 2 by any chance? I kinda like the Crash Team Franchise and with the extra grunt the PS2 has over the PlayStation I think that another Crash game would rock. I hope you can answer these questions for me as I desperately need to know the answers.

#### MATTHEW SMITH, QLD

*Hi Matthew, Currently, the Dreamcast is a great console, so there's little reason why you shouldn't buy and enjoy it now. The Dolphin is looking like a late 2001 release, that much is true. The X-Box could launch around the same time, so there's going to be some serious competition out there. Sonic Adventure 2 will undoubtedly be one classy as hell game, as the Sonic Team have always made great platformers. Platformers are going to be thick and fast on all the systems, so maybe you should wait until you see the game you MUST have, and then you'll know which console you need to buy...*

#### GETTING CONNECTED

To all you champs at Hyper, I've been a reader since issue 3 and have just recently decided to subscribe to your fantastic mag, stupid I know but I

just never did. Anyhow to my yarn. I have been a console gamer since day one of the Megadrive and have gone through it, a SNES, a Saturn, an N64 (that I still own, only for Rogue Squadron), my wonderful PlayStation that has kept me company on many a rainy day (and the only one I can see myself playing years after the purchase of my PS2) and recently bought a computer, a PIII 550Mhz, 128MB RAM, 32Meg TNT2 and some weird sound card that beats the shit out of my dads \$1600 stereo TV! Well, to get to the point, I went to get playing online, which is the main reason me and my parents went halves in this thing to start with, until I found I've got no idea where to start. I got a copy of Half Life (from the advice of a friend) and got good at the one player game. I then wanted to turn to the multiplayer game where I hit a brick wall. All the stuff on the net is too confusing for a new PC gamer, especially after being spoon-fed on consoles for so long. I was wondering if you could do a segment on setting up a multiplayer connection in a future issue, or at least direct me to a site that puts online gaming into a language a normal person can understand. If you can I would be highly grateful and forever in your debt.

Thanxs heaps,

#### REGGIE.

*Hi Reggie! Playing online isn't too hard. You should be using a 56k modem at the very least. Go and download something like GameSpy, as it looks up servers for you to play on for most of the popular games - like Half Life. You then usually just double click the game you want to join and it launches for you. Go to www.gamespy.com and see what they have to offer... oh and we're running a feature soon on how to set up your own LAN... you could say that should help somewhat!*

AUSTRALIA'S NEW GAMES SITE

www.consolehaven.com.au

100% Australian Gaming News, Reviews, Cheats and Comps,

100% FREE!



## BICKERING PART XVII

Hyper,  
I would just like to say that all these PS2 versus DC letters are pointless! What I mean is that a console is only as good as its software. Saying that the PS2 is better or DC is better is not enough. Me, personally, from what I have seen of the PS2, I am very disappointed because it's just the same as the PSX only with better graphics. The Dreamcast however is a completely new machine from the Saturn. I think Sony could have done a much better job with PS2, e.g. 4 controller ports, cheaper price and even newly designed controllers. Don't get me wrong, I'm looking forward to the PS2 but I won't go out and buy one. I bought a DC at launch and am now regretting it because N64 games come out faster. I'm sorry but I think speed and graphics have now taken over playability and good old fashion fun. Nintendo were right to make the Dolphin a games-only machine because games is what this industry is all about, not DVD movies and 20,000,000 polygons per second.

**AMWAR NEHME**

*Dear Amwar,  
Console war bickering is totally pointless, we agree! But just to correct a few things you've said... N64 games are not coming out faster than Dreamcast games. In fact, there are less and less titles on the N64 as time goes on. The Dreamcast however has a sackload of great games on the way. Also, the Nintendo Dolphin, whilst surely having games as it's focus, will still have DVD compatibility. There's no way Nintendo would put out a DVD-based console and not have DVD movie compatible - that would be stupid! You are right about the fun and gameplay being lost from a lot of new games, with the focus being on polygons or speed. That's a shame, but hopefully the companies involved*

*will soon wake up to that and get some more innovative titles out there.*

## PAINFUL THOUGHTS

Hyper and Readers,  
While I was reading your violence/OFLC feature, I noticed that you mentioned that in one of the cut scenes from Soldier of Fortune, the bad dude executes an innocent civilian. The more I think about it, the more it occurs to me how excessive that is. My concern however is that at first I dismissed it as a normal thing. It's quite scary how desensitised I am to violence. I think this is where the real issue lies. Not that we are encouraged to think and act violently, but that we are not affected by violence. That it doesn't register as a bad thing. I recall when Die Hard Trilogy first came out and I got heavily into the 3rd part - the bomb chase section. I was playing while my mother was in the room. She was shouting at me, 'stop hitting people'. I was thinking 'what people? Where's the damn bomb!'. I stopped to think and realised that I was so distracted in trying to find the bomb that I didn't notice I was smashing people all over my windscreen and wiping them off without a second thought. OK, yes, it's true as the cliché goes 'we are not going to run into a shop and fire a rocket launcher at people', but in all seriousness, when you hear about someone getting shot in the US does it really shock you? Not particularly. I don't know, perhaps I just have a sick mind. That's my 2 cents anyway.

Regards,

## OURPAIN

P.S. Having said that, I'm all for an 18+ classification. We are mature adults and have the right to choose our gaming thank you very much.

*Hi ourpain,  
Thanks for your response to the feature. Soldier of Fortune made most of*



OUR BEST JEDI POWER BATTLES DRAWING COMP ENTRY. DANIEL DOUGLAS OF TASMANIA YOU ARE A MASTER!

*the people here at the office do a double take, and actually stop to think about whether it was fun or not to chop bodies into a bloody pulp. It prompted us to do the feature, because we realised that it was simply sensationalist and added nothing to the*

*gameplay. At it's heart, SOF was a challenging shooter, but became rather tiresome, relying too heavily on the shock factor and not the fun factor. We ARE becoming desensitised, so hopefully some developers will start offering us some more intelligent gameplay.*

## OOZING!

Hey there,  
Just got the July issue of Hyper and I have to say that it's one of the best I've read so far (and I've been getting Hyper since issue #1). The X-Box feature, the Deus Ex review, the censorship/violence feature (long overdue, but extremely well done), and the whole look and feel of the mag recently has really been of an exceptionally high standard. I think you can really tell by reading a magazine if the people putting it together have put their hearts and souls into it. You open up the pages of Hyper and it just oozes professionalism (at least I think that's what that stuff was...). So all you clowns out there who have been complaining about price increases and all other sorts of petty shit, just pick up an issue and see what you're getting for your money.

Cheers,

**GIUSEPPE MARINO**

*Dear Giuseppe,  
How much did you want that cheque made out for?*



## Gamester PSX Dual Force Wheel.

Don't forget to include your contact details ON your letter. You've won a Gamester Steering Wheel! For PlayStation.





## FOR SALE

Neon Genesis Evangelion Adult VCD, not available in Australia, VCD still in original packaging \$20. If interested, e-mail me at [toolz\\_au@yahoo.com](mailto:toolz_au@yahoo.com)

Sega Dreamcast, 2 controllers, keyboard, VMU, Sonic & Soul Calibur. The lot \$550. Call Paul on (02) 4271 5162 or email [frostillicas@bigpond.com](mailto:frostillicas@bigpond.com) Wollongong pick-up only.

Nintendo 64, 2 controllers, memory pak, rumble pak, 7 games inc, Goldeneye and Zelda \$250 ono phone Ben on (02) 43339735

Bargain Game Boy games, brand new, never used, Top Gear Rally, 720 skateboarding, Mortal Kombat 4, Ready 2 Rumble boxing and Catwoman. 5 games for \$100 o.n.o (worth \$250). Phone Sasha on (02) 4576 5040 after 6pm or E-mail [sashaliu@hotmail.com](mailto:sashaliu@hotmail.com)

Hello I am Josh, I am desperately trying to sell: Sega mega drive (Excellent condition) with two controllers and 4 games, Sonic, Rugby world cup 95 and G-loc air battle \$40 ono. For GameBoy: Donkey Kong 3 (boxed with instructions) \$25, Zelda Links Awakening Dx (also with instructions) \$30 ono, Wario Land \$15, Mario And Yoshi \$10 ono, Kirby's Dreamland \$12, Turok 2 \$32. For P.C: Grand Theft Auto (Boxed with cheats) \$300ono, Star Wars The Phantom Menace \$55 ono. Will swap all of this for a Nintendo 64 (any condition) with 1 controller and 1 game (any game except Tetris or any other gay game like that. If you are interested in any of these games, phone 97586494.

PlayStation console: one dual shock, 3mem cards, 11 games incl. Final Fantasy 7/8, Metal Gear Solid, Gran Turismo, Soulblade, V-Rally

2, NFS: high stakes and 4 demos all boxed, good condition. \$300 ono Perth only. [danielch@one.net.au](mailto:danielch@one.net.au)

LucasArts Archives Volume 3, everything included box, manual etc. -\$25, Need for Speed 2 and NHL 98 \$10 each, no box, all games in very good condition, have hardly been played. Ph.07 33789764 (Brisbane Only)

N64 for sale. Console with all cords and plugs, with 1 limited edition gold controller, 4 games: Turok 2, Zelda 64, Donkey Kong 64 (with 4MB pack) and Forsaken (all boxed with booklets). Also 1 memory pack, 1 tremor pack, 1 extra 4 MB expansion pack all in very good condition, only \$420. Buy now and I'll throw in Korn: issues or soundtrack to American Pie free. Write to [vugufish@icqmail.com](mailto:vugufish@icqmail.com) or PO Bow 51 Hall ACT 2618.

32Mb RIVA TNT2, AGP, almost brand new. If you are interested call Andrew on (02) 62810353.

Sega Saturn 16 games all with instructions) 2 demos, 3 controls all in good condition still in box with some of the most popular games. \$220 phone 98221439 after 4pm weekdays.

American (NTSC) Dreamcast with two controllers, 1 VMU, 3 games - Armada, Sonic Adventure, Soul Calibur. Everything in perfect condition, comes with all boxes and cases. \$550. Needs power converter to play. PH - (07) 4946 1268. Email - [wilsford@mackay.net.au](mailto:wilsford@mackay.net.au)

Dreamcast games: Ready 2 Rumble Boxing (\$60), Sonic Adventure (\$50), Toy Commander (\$50), Power Stone (\$50), or all games for \$160. Ask for Ben on (02) 6679 7145

Dreamcast games. All as

new, all PAL. Wild Metal (\$50), Toy Commander (\$50), Crazy Taxi (\$60), Sega Rally (\$55), Sonic Adventure (\$50). Ring Jamie on (020) 65 683 695

## WANTED

Wanted. Keio 2 Flying Squadron, for the Sega Saturn, other Sega Saturn games considered. Contact Shayn - email [angrybunny@one.net.au](mailto:angrybunny@one.net.au)

I am desperately in need of the Dark Reign expansion. Will pay up to \$20 for it (must have instructions) don't mind if not in box. If you have, then call me on 95583720 between 4 and 8 pm and ask for Chris or email me at [chris\\_lois22@hotmail.com](mailto:chris_lois22@hotmail.com)

Atari 2600 wanted desperately. All my games lie idle. Will pay any sane price. email cossies tig.com.au or phone Trent on (02) 98296489 after 5pm.

Secret of Mana for SNES (PAL version). Willing to pay \$50. Email me at [kingofhumour@hotmail.com](mailto:kingofhumour@hotmail.com) or call me on (08) 94571572. Please I've looked everywhere!

3DO console (brand of no concern) with a few games, Neo Geo/Neo Geo CD console/s with a few games, Mega Drive/Mega CD consoles with a few games. Will pay good \$\$\$.

Details to be sorted upon contact. Email Matt at [flagy@hotmail.com](mailto:flagy@hotmail.com), or call (07) 40452445 and let me know what you've got.

Wanted - Flanker 2 (PC flight sim), with box and manual and must be in good condition. No pirated shit, I have principles. Will pay \$30 - \$50. E-mail me at [i\\_like\\_dogs@dog.com](mailto:i_like_dogs@dog.com)

I'm looking for the following DC games (PAL ver.): Soul Calibur, Dead Or Alive 2, Sega Rally 2, Crazy

Taxi. Will pay up to \$45 depending on the cond. of the games. Contact Bill (02) 9708 4575 or email [idohtateu@yahoo.com](mailto:idohtateu@yahoo.com)

I am looking for War Hammer 40,000: Chaos Gate. Will pay of 40 dollars, neg. Call 9481 4870 ask for Shae. Melbourne areas only .

Out of this World 2 - Heart of the Alien. Very old and rare game. Prefer PC version but not fussy. Will pay a LOT. Contact Mat on (07) 3217 4727 or email [zenstorm@hotmail.com](mailto:zenstorm@hotmail.com)

Wanted for Sega Saturn (PAL) Dragon Force and any King Of Fighters/Fatal Fury. Must be boxed with manual and in good condition. Also looking for a copy of King Of Fighters 95 for PlayStation. Contact Carlo on (07) 3899 9857 or e-mail at [yoshimyu@ozemail.com.au](mailto:yoshimyu@ozemail.com.au)

I am desperately seeking Pilotwings and F Zero for the SNES (NOT the N64 versions). Games must have boxes and instructions that are in very good condition. I will pick up from anywhere in Australia (C.O.D.). I will pay top dollar for these games. Call Rod after 6pm on (02) 43 928 498

Desperately in need of "The Games Factory" for PC. Call Chris after school on (03) 6324 7512. Will pay up to \$50

## PENPALS

Hello. Seeking penpal: preferably between 10-15, female or male who is into the internet and/or Final Fantasy 8 or any strategy game. Must like PlayStation and preferably lives in Queensland. Thank! E-Mail me at [Tyr\\_Pickles461@bigpond.com](mailto:Tyr_Pickles461@bigpond.com) or call me at (07) 49362174.

Hi my name is Melissa, I am 13years old and I am looking for a pen pal, male if possible aged between 12 to 15 years old. I like to talk about

anything really. Melissa Draper, 8 Stoney Road, Belgrave, Melbourne, Vic 3160.

Female 46 years keen on RPG style games like Final fantasy, also Tomb Raider, Mario 64 etc. I am 5ft 7 tall, dark hair and asertive nature. I am interested in corresponding with men 40 to 55 years old, conservative appearance but broadminded, soft gentle nature, and taller than me. If you are in Sydney and play any of the above games, write to: F.S. PO Box 665, Engadine, 2233.

Greetings. I come from far away to destroy your planet. Surrender now... or die. Yours sincerely, Ming the Merciless.

Hey, my name is Joanna Xuereb and I'm 17. Well, I'm looking for female penpals aged between 15 & 19. So get out some paper and pens and start writing to me at: Joanne Xuereb, 45 Wattle Avenue, St. Mary's North, NSW 2760.

My name is Chris and I'm 15, looking for penpals both female and male. So write to me! Chris Xuereb, 45 Wattle Ave, St. Mary's North, NSW 2760

Hi my name is John. I'm looking for friends. You see, I'm running a country and I don't know the first thing about it. I can't say the word "Sorry" and I introduced the GST which is going to make life more expensive, and interest rates are going to go up. Please write to me at Johnny's Palace, Canberra, ACT and be my friend.

Hello! My name is Eliot and I'm the editor of this magazine. I'm looking for people to draw wonderful pictures for us to display in the letters section. So what are you waiting for? Send us your reader art! Reader Art, Hyper, 78 Renwick St, Redfern, NSW 2016.



# NEXT ISSUE

PC



PLAYSTATION



DREAMCAST



NINTENDO 64



**AND MUCH, MUCH MORE!**  
**PLUS!**  
**THE FUTURE OF GAMING...**

PART 2 of

See what some more games industry giants think of the current state of console gaming and the future of the PC, plus get some peeks at some games they're working on!

## IN-DEPTH FREELANCER PREVIEW AND INTERVIEW

Chris Roberts himself guides us through the golden moments of his upcoming Space Combat masterpiece, Freelancer, the non-linear sequel to StarLancer.

## DEUS EX EXPOSED!

Interview with the creator of Deus Ex, System Shock 2 and Ultima Underworld — Warren Spector!





**DESTROY ALL YOU WANT. WE'LL MAKE MORE.**



Tread not where you are unwanted. Or pay the ultimate price. If sheer numbers are not your downfall, alien creatures and mysterious opponents of unfathomable strength surely will be. But, wise Jedi, the choice is yours. Enter at your own risk.

# STAR WARS EPISODE I JEDI POWER BATTLES

[jedipowerbattles.lucasarts.com](http://jedipowerbattles.lucasarts.com)  
[www.starwars.com](http://www.starwars.com)

Exclusively distributed by Metro Games. For trade enquires call (03) 9820 5588 or visit us at [www.metrogames.com.au](http://www.metrogames.com.au) to WIN A FREE Demo CD of the game.

© Lucasfilm Ltd & TM. All rights reserved. Used under authorization. PlayStation and the PlayStation logo are registered trademarks of Sony Computer Entertainment Inc.



**TRUST A FEW... FEAR THE REST**  
**THE EVOLUTION BEGINS JULY 13 IN CINEMAS EVERYWHERE**

# X-MEN

 Office of Film and Literature Classification  
THIS FILM IS YET TO BE CLASSIFIED

**See it first @ [www.foxmovies.com.au](http://www.foxmovies.com.au)**



© 2000 TWENTIETH CENTURY FOX