

NINTENDO⁶⁴ LAUNCHES AT \$199!

ELECTRONIC GAMING MONTHLY

NUMBER

87

YOUR GUIDE TO:

Nintendo⁶⁴
PlayStation-Saturn
Super NES-Genesis
Game Boy-Game Gear
Neo-Geo-3DO

120 STARS REVEALED MARIO⁶⁴

- 16-PAGE STRATEGY GUIDE
- TONS OF SECRET TRICKS
- 3-D BLOWOUT MAPS



OVER 50 previews

PLAYSTATION'S GREATEST ADVENTURE!

TOMB RAIDER

playstation
RPG
BUYER'S GUIDE

WORLD EXCLUSIVE

4 NEVER SEEN BEFORE NINTENDO⁶⁴ GAMES!

LEGACY OF KAIN • TECMO'S DECEPTION
ARG THE LAD 2 • BREATH OF FIRE 3
BEYOND THE BEYOND • KING'S FIELD 2



October, 1996
\$4.99/\$6.50 Canada





AOL@keyword:NOA
www.nintendo.com

THE NEW MOVES YOU BET A DOUBLE- THU

Introducing Super Mario™ 64. A total revolution in more ways than one.



PLAY THE NOW, TER HAVE JOINTED M.B.



Coming Sept. 30 to a screen near you.

NINTENDO⁶⁴



CHANGE THE SYSTEM.



EVERYTHING ELSE TAKES A BACKSEAT.



POWERED BY
namco





RIDGE RACER REVOLUTION

THE FASTEST RACERS ON EARTH.™

are trademarks of Sony Computer Entertainment. The ratings icon is a trademark of the Interactive Digital Software Association.

NUMBER 9.10
OCTOBER 1996

ELECTRONIC GAMING MONTHLY

By **Ed Semrad**

The holiday shopping season is rapidly approaching and this time, it looks like it is going to be a banner year.

Now that all the systems are below the \$200 threshold (Nintendo just announced a drop in price from \$259 to \$199), the big three are planning on selling everything that they can get in from Japan. Already there are spot shortages of both PlayStations and Saturns here in Chicago and the official shopping season is still a whole month away. As for getting an N64? Good luck. You had better have placed a pre-order (even though there appears to be only two carts out at launch), the buzz about Mario is so hot that it'll carry the system until NoA decides to release a second batch of games.

As for the other guys, Sega has a couple of arcade sequels and the new Sonic disc to help drive sales, while Sony has Crash, Twisted Metal 2, WipeOut XL, a long list of RPGs to win back those who thought the Saturn was *the* RPG system and a whole series of hot sports games to entice players to upgrade from their 16-Bit system.

Who will be the winner come January? That's easy. Sony is comfortably ahead now and they aren't looking back. They are rapidly filling in the previously empty niche 'holes' in their game inventory and the PlayStation seems to have no weaknesses. While each of the three systems will sell well, Nintendo can't get enough systems to the U.S., and there just aren't enough "AAA" rated Saturn-only games to put Sega first in the system race. But, second or third isn't necessarily bad especially when each company, worldwide, will have millions of systems in the homes (and the race is far from over). The best advice: Look at the games coming out for each of the systems and go with the one that has the most titles that interest you.

In other news, information is slowly beginning to leak out from



Ed tries to get a grip on Sony's new controller.

the Nintendo licensees in Japan. Seta was one of the first companies with early pictures of their golf, helicopter and racing carts. Kemco is starting to talk as is Konami and Square. Nintendo of Japan should be bringing out some of their second tier of titles as early as this month with Wave Race leading the pack and Mario Kart and Kirby a month or so later. However here in the States we might not see these games until late this year.

Lastly, our sources in Japan have been noticing that Virtua Fighter 3 has been appearing on test at various Sega arcades. We're on our way to JAMMA (the main Japanese arcade show) so watch for a hands-on review in the next issue. Also we've been hearing rumors of Street Fighter 3 coming out in December (with the home versions due sometime in summer 1997), so this could finally be the world debut of the long-, long-, long-anticipated SF3. Or will Capcom chicken out and do a Street Fighter Alpha 3? Also, where does that leave the third major player—Namco? They have been very quiet the last few months and that could just mean that Tekken 3 is about ready. Needless to say, this could be the arcade show of the decade. No matter what, we'll be there and if you're even remotely interested in arcade games, you won't want to miss our November issue where JAMMA and two other trade shows will be spotlighted with exclusive pictures and information.

Founder Steve Harris

Publisher Jonathan Lane
Editorial Director Joe Funk
Editor in Chief Ed Semrad
Associate Editors Crispin Boyer
Shawn Smith
Dan Hsu
Scott Parus

Third-Party Liaison John Stockhausen
Sports Editor Todd Mowatt
News Editor Nelson Taruc
West Coast Editor Kelly Rickards
Strategy Editors Ron Marciniak • Mike Vallas
Tricks Editor Terry Münich
Contributing Editors Howard Grossman
Andrew Baran • Sushi-X
Tim Davis • Dindo Perez
John Gurka • Jason Streetz
Mark Hain • Dave Malec
Dave Ruchala • Carey Wise
Scott Augustyn

Online Editor Joe Fielder
Managing Copy Editor Jennifer Whitesides
Senior Copy Editor Jo-El M. Darnen
Copy Editor Dan Peluso • Mark Eleveld
Foreign Correspondents Stuart Levy • David Rider

Creative Director Michael Stassus
Art Director Jason Hinman
Layout & Design Paul Ojeda
Mike Desmond

Production Director Marc Camron
Production Coordinator John Born
Production Manager Dave McCracken
Assistant Production Manager Jack Copley
Advertising Coordinator Mike Darling
Systems Coordinator Mark Lefebvre

Single Copy Sales Director Joan McInerney

Advertising Eisenberg Communications
Inquiries Group Inc.
Contact: 20700 Ventura Blvd.,
Suite 205
Woodland Hills, CA 91364
(818) 712-9400

National Ad Director Jeffrey Eisenberg
National Ad Manager Jon Yoffie
Account Executive Karen Landon
Ad Coordinator Suzanne Farrell

ELECTRONIC GAMING MONTHLY (ISSN #1058-918X) is published monthly by Ziff-Davis Publishing Company, 1920 Highland Ave., Suite 222, Lombard, Illinois, 60148. Periodicals Mail Postage Paid at Lombard, IL and additional mailing offices. Subscription rates for U.S., \$24.97 and all others, \$40.97. Single issue rates: \$4.99. POSTMASTER: For subscription changes, change of address, write to: Electronic Gaming Monthly, P.O. Box 5722, Boulder, CO 80322-9722. E-mail: egm@inediata.com. The editors and the publisher are not responsible for unsolicited materials. Without limiting the rights under copyright reserved herein, no part of this publication may be reproduced, stored in, or introduced into a retrieval system, or transmitted, in any form, or by any means (electronic, mechanical, photocopying, recording, or otherwise), without the prior written notice of Ziff-Davis Publishing Company, ©1996 Ziff-Davis Publishing Company. All Rights Reserved. Electronic Gaming Monthly and EGM are trademarks of Ziff-Davis Publishing Company. TM and © for all other products and the characters contained herein owned by the respective trademark and copyright owners. All materials listed in this magazine are subject to manufacturers' change and the publisher assumes no responsibility for such changes. The Canadian GST Registration number is 1404967-20 RT. Printed in the USA.

Auditt Bureau of Circulations

THE LOST GENERATION OF GAMING.

For the next generation.

TERRIFYING MONSTERS!
SEMI-REALISTIC GRAPHICS!

100 TOTALLY LINEAR LEVELS.

100% RENDERED
BLACK VOID.

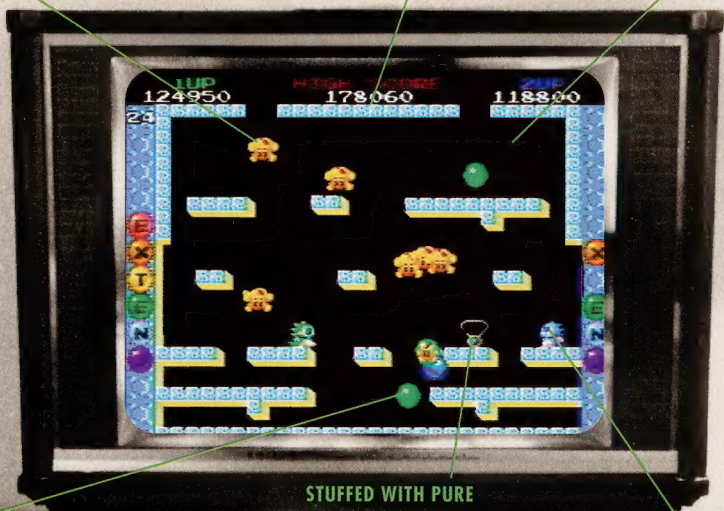

3-D'ISH BALLOONS WITH
SINGLE LIGHT SOURCING!

STUFFED WITH PURE
ADDICTIVE GAMING NECTAR.

YOU ARE 6-PIXELS OF
BUBBLE-BLASTING DINOSAUR
WITH AN ATTITUDE!

2 classic arcade games in 1

Bubble Bobble®

also featuring Rainbow Islands™

ADDICTION GOES RETRO!



Bubble Bobble® is a registered trademark of Taito Corporation. © Taito Corporation 1986-1988. All rights reserved. Rainbow Islands™ is a trademark of Taito Corporation. © Taito Corporation 1987-1988. All rights reserved. PlayStation and the "PS" logo are trademarks of Sony Computer Entertainment, Inc. Sega and Sega Saturn are trademarks of SEGA ENTERPRISES, LTD. All rights reserved. Acclaim is a division and registered trademark of Acclaim Entertainment, Inc. © & © 1996 Acclaim Entertainment, Inc. All rights reserved. Screen shot shown was taken from PlayStation version of the videogame.

Acclaim®
entertainment inc.
www.acclaimnation.com

25 grisly minutes of full motion 3D animation. Slaughter your enemies as a Vampire then morph to a wolf, escaping into the dead of night.

Butcher villagers or turn them into festering pools of decaying flesh with one of 22 demented magics. It will take you more than 100 hours of adventure to destroy those who damned you, but you'll get them. Every last bloody one.





Forever. It is a black and
dreadful place. Where the
undead feast on the living

ETERNAL DAMNATION LEAVES PLENTY OF TIME TO PLAN YOUR REVENGE

to survive. Welcome to
Crystal Dynamic's Blood
Omen: Legacy of Kain.
Whether you choose the
body of man, the form of
wolf or the cloak of mist, the
search for and annihilation
of those who damned you is
your only purpose.



Explore the carnage at www.crystd.com

Crystal Dynamic and Blood Omen: Legacy of Kain are trademarks of Crystal Dynamic. ©1998 Crystal Dynamic. All rights reserved. PlayStation and the PlayStation logo are trademarks of Sony Computer Entertainment, Inc.



**CRYSTAL
DYNAMICS™**

Get YOUR FIX!



Craving...
**...for the best video
game mag on the planet?**

Look for the EGM subscription
card stuck in this magazine
and send it away today!

ELECTRONIC GAMING MONTHLY

ZIFF-DAVIS PUBLISHING
CHAIRMAN AND CEO Eric Hippeau

President, U.S. Publications	Ronni Sonnenberg
President, Interactive Media and Development Group	Jeffrey Ballowe
President, International Media Group	J.B. Holston III
President, Computer Intelligence/Infocorp	Bob Brown
President, Training and Support Publishing Group	William Rosenthal
Vice President, Chief Financial Officer	Timothy O'Brien
Vice President, General Counsel and Secretary	J. Malcolm Morris
Vice President, Human Resources	Rayna Brown
Vice President, Planning	Darryll Otte
Vice President, Production	Roger Herrmann
Vice President, Controller	Mark Moyer
Treasurer	Thomas L. Wright

U.S. Publications Group

President, U.S. Publications	Ronni Sonnenberg
President, Business Media Group	Claude Sheer
President, Consumer Media Group	J. Scott Briggs
Senior Vice President, Circulation	Baird Davis
Senior Vice President, Consumer Advertising	Lawrence C. Burstein
Vice President, Business Manager	Tom McGrade
Vice President, Marketing Services	Jim Manning
Vice President, Central Advertising Sales	Bob Bader
Vice President, Product Testing	Mark Van Name
Vice President, Circulation Services	James F. Ramaley
Vice President	Don Byrnes
Vice President	Al DiGuido
Vice President	Daniel Farber
Vice President	Michael Miller
Vice President	Daniel Rosenweig
Vice President	Paul Somerson
Executive Director, Licensing	Gertrud Borchardt
Director, ZD Labs	Bob Kane
Director, Benchmark Operation	Bill Catchings
Ziff-Davis Magazine Network Vice President	Joe Gillespie
Managing Director	
Executive Director	Alicia Saribalis
Marketing Director	Mike Perkowski
Directors	Ken Beach, Michael Bird, Jeff Bruce, Kelly Lowman, Debbie Weiss, Julie Tuttle, Melinda Maginn

Interactive Media And Development Group

President	Jeffrey Ballowe
Executive Vice President	David Shneider
Vice President, Business Development	Tom Thompson
Vice President, General Manager ZD Net	James Savage
Vice President, ZDTV	Richard Fisher
Vice President, Creative Services	Herbert Stern
Vice President, Research	Eida Vale
Editorial Director, New Products	Bill Machrone
Group Business Manager	Jocelyn Grayson
Director, Public Relations	Gregory Jarboe

Ziff-Davis Publishing Company,
A SOFTBANK Company

PREPARE TO FLY.

/ and soar and spin and climb and dive and look way, way down on everything else /

NIGHTSTM into dreams ...

IS HERE.

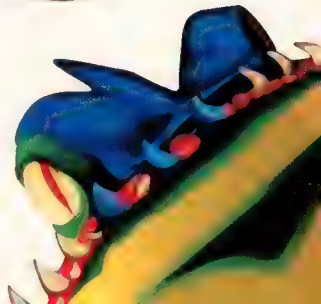





*Never, ever, ever, have you experienced anything like this.
Never, ever, ever, have you been able to fly, float and free, in real-time 3D.*

NOT UNTIL NIGHTS.

THE MOST REVOLUTIONARY NEXT-GENERATION GAME EVER. THE FIRST TRUE SHOWCASE OF SEGA SATURN'S STUNNING CAPABILITIES. THE TECHNOLOGICAL TOUR DE FORCE THAT HAS EVERYONE IN THE GAMING WORLD ABSOLUTELY SPUN.

THE STORY ONE OF THE MOST IMMERSIVE, MYSTICAL GAMING EXPERIENCES EVER, NIGHTS ESTABLISHES AN ENTIRELY NEW GAMEPLAY PARADIGM. THINK OF IT AS PSYCHODRAMA, AN EXPRESS ESCALATOR INTO THE SCHIZOPHRENIC, MIND-BENDING VIRTUAL WORLD OF YOUR DREAMS. RICOCOETING BETWEEN LIGHTER-THAN-AIR REVERIES AND DARK, MACABRE NIGHTMARES, NIGHTS BRINGS YOU FACE TO FACE WITH BOTH YOUR GUIDING SPIRITS AND YOUR INNERMOST DEMONS.

THE WORLD

CREATED BY THE RENOWNED SONIC TEAM, NIGHTS IS A FULL-ON 3D MASTERPIECE. A WORLD WITH SOME OF THE MOST VIBRANT, INSPIRED, ORIGINAL GRAPHICS EVER CONCEIVED BY FEVERED IMAGINATIONS. A WORLD WITH DEEP, LUSH, DREAMSCAPE REALITIES, ITS OWN MICRO-CLIMATES, EVEN ITS OWN NATURAL ORDER. IMAGINE. SMOKE, FOG, CLOUDS, RAIN, AND WATER THAT APPEAR IN MULTIPLE LEVELS OF TRANSPARENCY. WATERFALLS, CURRENTS, WIND, AND, YES, A TORNADO THAT ALL FOLLOW THE LAWS OF FLUID PHYSICS. INDEPENDENT LIGHT SOURCES THAT PLAY ON BOTH ACTION AND BACKGROUNDS AT DIFFERENT, SHIFTING LUMINOSITIES. ALL BACKED BY A RAGING SOUNDTRACK THAT BLENDS JAZZ, ORCHESTRA, ROCK, WORLD MUSIC, AND EFFECTS.

THE GAMEPLAY

NIGHTS SCREAMS ALONG AT BANSHEE ITS ADAPTIVE SPEED MANAGEMENT GAMEPLAY AND BREAKTHROUGH TO REPLICATE THE TRUE SENSATIONS OF FLIGHT. SEQUENCES. ITS OVER TWENTY TRACKING IN REAL TIME. AND ITS OMNIPRESENT

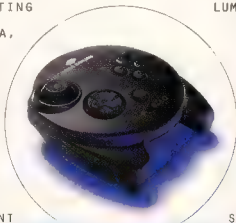

SPEED. DESPITE MASSIVE 3D DEMANDS, SYSTEM SUPPORTS BOTH BREAKNECK ENVIRONMENTS. WITNESS ITS ABILITY ITS LIGHTNING MULTIPLE MORPH CAMERA ANGLES THAT SCROLL-SHIFT SYMPHONY OF 3D POSITIONAL SOUND.

THE NEW 3D CONTROL PAD

ENGINEERED SPECIFICALLY TO INTENSIFY THE NIGHTS EXPERIENCE, SEGA SATURN'S 3D CONTROL PAD ESTABLISHES A NEW BENCHMARK IN SMOOTH AND DYNAMIC OPERATION. IN ANALOG MODE, ITS PULSE-SENSITIVE THUMBPAD ENABLES UNPRECEDENTED MANEUVERABILITY AT BREATHTAKING SPEEDS. SWITCHING TO DIGITAL MODE ALLOWS COMPATIBILITY WITH ALMOST ALL OTHER SEGA SATURN GAMES.

(PLEASE CALL 1-800-USA-SEGA FOR ANY COMPATIBILITY QUESTIONS.)

The Benediction

There's more, of course. But the rest is up to you. So kick off your walking shoes. Say your prayers. And fly. No way you'll sleep. But you'll have wicked good dreams.

NIGHTS

ONLY ON



SEGA SATURN



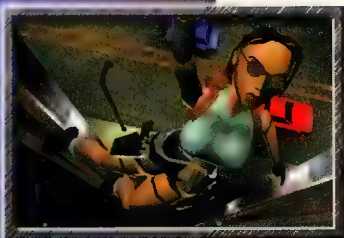

TOMB RAIDER

INDIANA JANE SWINGS INTO ACTION IN TOMB RAIDER. BUT IF YOU THINK THE HEROINE IS A BIT SQUEAMISH...*THINK* AGAIN! THE STORY BEGINS ON PAGE 92!

GAME directory

Alien Trilogy	156	Perfect Weapon	154-55
Amorphous Rebirth	178	Phantom 4x	95
Area 51	128-29	Pitfall Rage	94
Ball Master Challenge	54	Pro Wrestling	99
Battlezone/Breakout	58	Project Overkill	92
Bigshot de Bayard	62,165-67	QF Club '97	176
Block Drives	136,150	Raid Assault	94
Blustards	52	Ra-Lambert	96
Boggy: Death II	81	Resident Evil	97
Bulky Buster	59	Ricochet	97
Clashback/Clash 2	56	Robo Fly	16,154
Contra	142-43	Saints Open Golf	98
Crashlands	174	Shadow	92
Dash Remastered	86	Shogun Warriors	91
Crab's USA	62	Spot Goes to Italy	62,153-65
Damper	144,146	Star Gladiator	160,162
Demon in the Disguise	45	Super Mario 64	74-88
Fighting Vipers	124-25	Tacno	170
Fist of Doom	50	Ten Pin Alley	170
Frost Fantasy V8	102-43	Tenka	67
Ghost Wars	55	Table Attack	86-94
Golden Axe TD	98	Table Flip	61,158
Grid Racers	61	Three King Demons	136,139
Gun Critics	52	Tiger Shark	83
Gunfire	79,83	TicTac 61	68
Hero's Adventure	44	Tekno Fighting Battle	62
Hive, The	82	Tomb Raider	62-63
International JAP	66	Top Gun	88
Legend of Drago	84	Tweaks/TOM	139-41
Manhattan	152-53	Twisted Metal 2	146-41
Madden NFL '97	168,178	UMKS	48,84-88
Major Damage	48	W3	118-17
Major Man II	53	Wreckamer: 64x	88
Ma, Pac-Man	66	Wreckers 64	176
NCAA Combats	178	Wild 8	66
Necrodome	40	Wild Choppers	30
Need for Speed	81	Wip-Out 3L	63
NHL '97	172	Worms	82,88-87
Pandemonium	142,149	X-Men 3	88

DEPARTMENTS

6 INSERT COIN

Our editor reminisces about the past and ponders the future.

20-28 PRESS START

The news that's making headlines in the world of video games.

34 GAMING GOSSIP

THE inside source on the gaming industry from Q-Mann.

38-57 NEXT WAVE PROTOS

Exclusive first-looks at games on the horizon.

60-66 REVIEW CREW

A no-holds-barred critique of gaming's latest releases.

72-87 TRICKS OF THE TRADE

Want a power trip? Check out the hottest cheats here.

92-117 SPECIAL FEATURES

An in-depth look at the newest of the new.

120-162 NEXT WAVE

Get a sneak peek at upcoming titles for all systems!

161,163,186 CONTESTS

Don't miss your chance to win BIG!

164-178 TEAM EGM

Previews and reviews for sports gamers.

182-185 INTERFACE

An open forum for readers' questions and concerns.



NUMBER

087

WIN BIG!

YOU WANT THE GOODS? Don't miss your chance to **ENTER THESE GREAT CONTESTS...** Win big money in Working Designs' Shining Wisdom contest, travel to the '97 Grand Pix with the Psygnosis Formula 1 sweepstakes or score an NBA Jam Extreme arcade game from Acclaim!

Score some fast cash or the hottest gaming goodies in this **once-in-a-lifetime** opportunity!

FEATURES

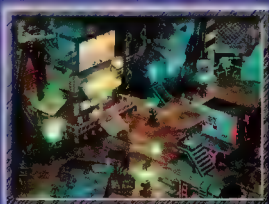

RPGERS' OUTCRIES HAVE BEEN HEARD BY SONY!

RPG lovers who own PlayStations have been screaming for role-playing games to be released for the PS. Well, Sony has heard their cries and answered them with a plethora of RPGs that'll be out shortly. Final Fantasy VII, Beyond the Beyond plus many others will grace the system! The story begins on page 94!

"Every aspect of the game (FF7) is highly cinematic."

SEGA SHOWED OFF HOT, NEW TITLES AT ITS SPECIAL DAY!

Recently, *EGM* flew to Sega's office for its Gamers' Day where our editors were shown some juicy, soon-to-be released titles. In this issue, check out what they saw: Sonic Xtreme, Mr. Bones, VectorMan 2, MechWarrior 2, ID4, Mega Man 8 and many more exciting Sega titles. The story begins on page 112.

"Sega's mascot finally makes an appearance on the Saturn."

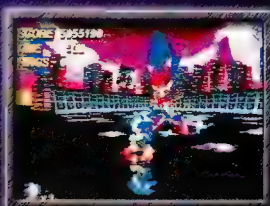

TWISTED METAL 2 RACES ACROSS THE WORLD!

Only in a demented (we mean that in a good way) game like Twisted Metal 2 could gamers get to blow up the Eiffel Tower for tricks. With its odd characters and their weapons, TM2 will satisfy any destruction buff's hunger. The story begins on page 140.

"Can there be more? Of course!"

NEXT WAVE



120 NINTENDO 64

Battle dinosaurs as a Native American in Turok: The Dinosaur Hunter

124 SATURN

Something fishy is happening at the Air Force base, Area 51. Is it aliens or bunk?

140 PLAYSTATION

Travel the world blowing up worldwide monuments in Twisted Metal 2!

MY TRIP TO SEATTLE

By CRASH BANDICOOT™



1. HERE'S ME DRIVING.



4. HERE'S ME SHOWING OFF MY GAME'S
REAL-TIME 3-D WORLD WITH
ITS LUSH, ORGANIC ENVIRONMENTS,
TONS OF OBSTACLES, SECRET PATHWAYS
AND BONUS LEVELS. OUTSIDE OF
NINTENDO® HEADQUARTERS.



5. HERE'S ME BEING ESCORTED BY SECURITY
THE PREMISES. BY SECURITY

For game hints call 1-900-933-SONY(7669). The charge is \$0.95 per minute. Callers under the age of 18 must get parental permission to call. Touch-tone phone is required. Available 24 hours a day/7 days a week. U.S. only. The Sony Computer Entertainment logo is a trademark of Sony Corporation. PlayStation and the PlayStation logos are trademarks of Sony Computer Entertainment Inc. U R NOT E is a trademark of Sony Interactive Entertainment Inc. "Crash Bandicoot" and the Crash Bandicoot logo are trademarks and copyrighted properties of Universal Interactive Studios, Inc. © 1996 Universal Interactive Studios, Inc. Source Code © 1996 Naughty Dog, Inc. Nintendo is a registered trademark of Nintendo of America Inc. The ratings icon is a registered trademark of the Interactive Digital Software Association. Screen shots are actual game screens taken from monitors. www.sony.com.





2. HERE'S ME AT THE SPACE NEEDLE.



3. HERE'S ME WITH SOME OF THE GALS AT SEATTLE SLIM'S.

MY GAME →

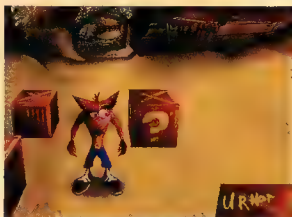

Crash Bandicoot

Sony's long-awaited entry into the platform game arena. You've never experienced anything quite as sensational as this fully animated cartoon world coming to life. It's flooded with obstacles, enormous levels, unbelievable graphics, detailed real-time lighting, amazing music and sound effects. Packed full of solid gameplay, hidden bonus levels, secret pathways and fiendish traps, this is the "must-have" game of the year. Travel in real time across 3D worlds in over 30 levels of intriguing gameplay with thousands of frames of animation! Interact with hilarious, fully rendered 3D cartoon-animated characters. It's packed with all the classic features of a character-based action game combined with solid controls.

PlayStation



MY LOGOS



**In 2096
Having a Bomb
Strapped to You
is a Sport.
[Want to Play?]**



BILABASTER™

The 3-D Rotatable Deathmatch

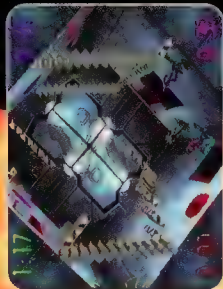

• 3-D rotatable chambers:
• 20 multi-player action chambers and
• 10 one-player strategy chambers



A variety of obstacles such as spikes,
trap doors, lava pits, and other deadly
surprises make each chamber unique

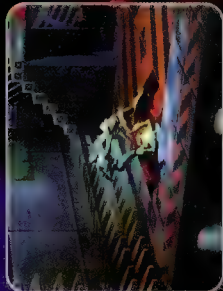

Intense multi-player mode with up
to four competitors, solo against computer
opponents, or solo against the clock



Realistic power-ups (revolving
magnetic poles, high jumps, psy-bombs,
crystal magnets) and more



ACTIVISION

THE BEST VIDEO GAME NEWS

PRESS
START\$199
N64!?!

EGM Analyzes the Real Reasons for Nintendo's Shocking Price Plunge



In North America, with orders already exceeding supply, the system will launch Sept. 30 at a manufacturer's suggested retail price of under \$250.*—Nintendo of America press release, July 30.

Virtually since day one of the Project Reality/Ultra/Nintendo 64 odyssey, Nintendo has pounded variations of the above quote into every press release and statement it has churned out. Indeed, amid the countless rumors and hearsay regarding the N64, the under-\$250 price was perhaps the one single fact that Nintendo stuck like glue to throughout the years.

Wrong, wrong, wrong.

The \$249.99 price tag officially went out the window Aug. 15, when Nintendo of America confirmed that the system would retail for \$199.99. Rumors of a \$50 price drop began just weeks before, and gained credibility when retail store computers began listing the N64 at \$199.99.

why bother?

Of course, Nintendo told no lies: The price remains "under \$250." Still, the widely assumed idea based on that statement was that the system would sell for \$249.99—one cent less. This practice is common among video game companies.

THE BIG STORY

MORE POWER

Quietly, Matsushita Has Revamped the M2 To Make It the Most Powerful Console Yet

Don't mistake silence for futility: While Matsushita has remained tight-lipped about its long-term M2 plans, it hasn't abandoned the system; some gamers have feared.

Actually, it's quite the opposite. Matsushita and its clique of M2 developers are reportedly plowing ahead for a 1997 release (spring in Japan, fall in the United States) for the 64-bit system. Matsushita has apparently decided to beef up the M2's specs, by adding another

Power PC processing chip and 5 MB of RAM for a total of 8 MB, according to online reports out of Japan (see specs on page 22). These reports also claim that Matsushita will show off M2s at the Electronic Entertainment Expo in Japan this fall. However, Matsushita officials have not confirmed M2 launch or show dates as of press time.

In the meantime, plenty of M2 work has been quietly going on

at Studio 3DO, which has 10 M2 titles in the works. EGM got the chance to visit Studio 3DO to get an updated glimpse of M2 development.

M2 system sightings

The visit allowed EGM to catch a glimpse of three M2 system prototypes. (According to various sources, the machine has undergone three major revisions; a fourth and final

hardware revision is slated to reach developers' hands by the time you read this.) The first M2 prototype was a second-generation system (it was current as of March) that featured 4 MB of SDRAM (Synchronous Dynamic Random Access Memory). The second prototype looked identical to the first—housed in an ominous-looking dark-blue console—but it was a third-generation machine, featuring

\$199 Nintendo 64 FRQ 01.0

■ Why did Nintendo drop the N64's price from \$249.99 to \$199.99?

Nintendo didn't make an official statement as of press time, but three prevailing theories exist. First, Nintendo may have been reacting to reported sluggish sales of the system after its strong launch in Japan. Second, it might be Nintendo's bid

to stay on par with Sony's and Sega's \$199-priced systems. Lastly, it might have been Nintendo's game plan all along—a surprise to rattle its competitors.

■ Is this \$199.99 just at certain stores? No. This is Nintendo's new suggested U.S. retail price.

■ Doesn't this new price make an N64 shortage

likely? Not necessarily. Nintendo made more than 800,000 N64s available in Japan in just over one month. That number suggests that the 500,000 U.S. N64s slated for three months may be a conservative figure, chosen perhaps to boost the presales frenzy.

Why the price drop? Nintendo officials steadfastly deny the price drop stems from disappointing system sales in Japan. One Japanese magazine conducted a survey that showed N64 sales being eclipsed by the Sony PlayStation just weeks after the N64's release, complete with pictures of N64s sitting unsold on store shelves.

Still, those troubles were attributed to lack of N64 titles. Even with that software handicap, Nintendo officials contend the company pulled in sales of 800,000 systems in just over six weeks—undoubtedly one of the most impressive system launches in video game history. Others believe Nintendo sought the price drop to compete better against the PlayStation and Sega Saturn, both of which dropped to \$199 earlier this year.

While that theory is certainly

Why would Nintendo make a surprise \$199 price switch, knowing gamers expected to pay \$249 anyway?

valid, it doesn't wash with Nintendo's statements just months ago, in which officials contended gamers would be more than willing to pay an extra \$50 above 32-Bit system prices in return for 64-Bit technology (and the ability to play Mario 64).

If that's the case, why would Nintendo make such a surprise price switch so close to launch, especially with the knowledge that a large contingent of U.S. gamers were fully expecting to shell out \$249 for an N64? After

all, Nintendo could lower the price to \$199 the moment sales of the N64 at \$249 begin to slow.

In fact, *EGM* has gotten word that the \$199 price drop was no last-second change of heart by Nintendo, as some assume. In fact, Nintendo may very well have planned to launch the N64 in the United States for \$199 all along—but deliver the message at a date late enough to prevent Sega and Sony from having the time to formulate a substantial pricing counterattack to hinder the N64's launch.

A source close to one of Nintendo's N64 first-party developers claims the company knew it would launch the N64 for under \$200 in the U.S.—and knew it since January of this year. Unfortunately, Nintendo officials were not available for comment on the veracity of this account.

(Continued on Page 28)

TO M2

of June) the amount of M2's SDRAM.

Encased in plastic, the most up-to-date M2 prototype contained 8 MB of SDRAM, confirming the reports out of Japan. Around 100 of these boards have been sent out to developers worldwide, according to SDO officials. All three boards can run off a quad-speed CD drive, which the production models will also have.



Like the chrome-covered Mario in Mario 64, this M2-modeled robot has reflective surfaces, but the M2 goes a step further by actually mirroring the environment onto the shiny metallic texture maps.

One **Nintendo** 64 Dream Team member has decided to stay on the bench, rather than continue playing—for now, at least.

Mindscape's "Monster Dunk" for the N64 has officially been put on "permanent hiatus," according to a company spokesperson. **Mindscape** made the decision on its own. The reason the project has been tabled is because of a lack of development systems and related resources—a problem that a lot of third-party publishers are reportedly facing with their titles. It's not surprising, considering **Nintendo** is busy with most of its focus on first-party titles. "It's tough being a third-party publisher for the N64 at this moment," a spokesperson said. Coincidentally, **Mindscape** is looking into **Sega** Saturn development, but has made no decision yet.

Nights
THE LEGEND OF THE ORDER OF THE NIGHTS

If you feel **Sega** has been missing something in recent Saturn TV advertising, you're right: there was no zany "Sega" scream. Well, the company is going back to its roots, reintroducing the trademark yell just in time for the rollout of its newest 32-Bit game, **NIGHTS**. The company is making this game the emphasis of its holiday push. On a side note, Saturn sales have doubled, and in some cases, tripled in volume since **Sega** cut the system price to \$199.99, according to a company statement.

MORE POWER TO M2

(Continued from Page 21)

It should be noted that the M2's RAM offers 12 times greater bandwidth compared to the RAM in the 32-Bit 3DO systems. M2's SDRAM runs at around 528

New M2 Specs

As reported by 3DO Magazine in Japan from MEI officials:

- Processors: 2
- Power PC 602 @ 66 MHz
- RAM: 8 MB
- CD-ROM: 4x-speed drive
- Resolution: 320 x 240 to 640 x 480
- Memory Bus Bandwidth: 528 MB/sec

MB/second. Compare that figure to the Nintendo 64's bus bandwidth, which is slightly faster at 562.5 MB/second. While both 64-Bit systems use SDRAM, the M2 has 16 KB of texture memory—four times that of the N64. Taking that into account with the M2's lightning-speed SDRAM, the M2 has the potential of producing the highest quality texture-mapped polygons of any console in history.

Along with the machines, Studio 3DO officials ran several new demos (which are not M2 games, officials stressed), of which many are shown here.

what about an upgrade?

Back to Japan: Officially, Panasonic has stated that it will provide an M2 upgrade to current 3DO owners. However, the major changes made with the main processors, RAM and other parts of the M2 may have placed an upgrade out of the 3DO's reach.

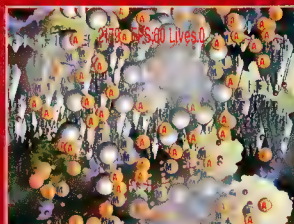

Demo 1 This 60 frames-per-second 2-D shooting game demo shows the M2 can easily spout out massive numbers of sprites on screen in 16-Bit color, and three levels of parallax. If that wasn't enough, it also shows alpha-blending effects, such as the foggy haze.

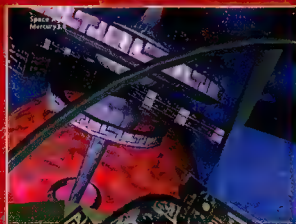

Demo 2 Entitled "Space Age Mercury," this demo showcases bi-linear filtering, a way of smoothing textures. The stars below are not set in a 2-D background, but mapped onto the interior of a sphere, resulting in strikingly accurate background scrolling.

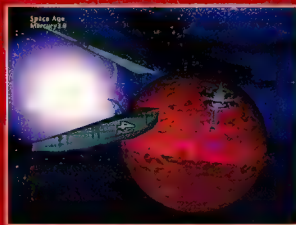

"I don't think that can happen," admitted one developer working closely with the M2 system. "The M2 is so vastly different, so alien in architecture, I can't imagine that you can modify the old 3DO" or produce an

upgrade add-on, the developer said. Online sources in Japan have speculated Panasonic may offer an M2 price discount to current 3DO owners. Unfortunately, the company has kept silent on this issue. ■

Dissecting the M2's Brains

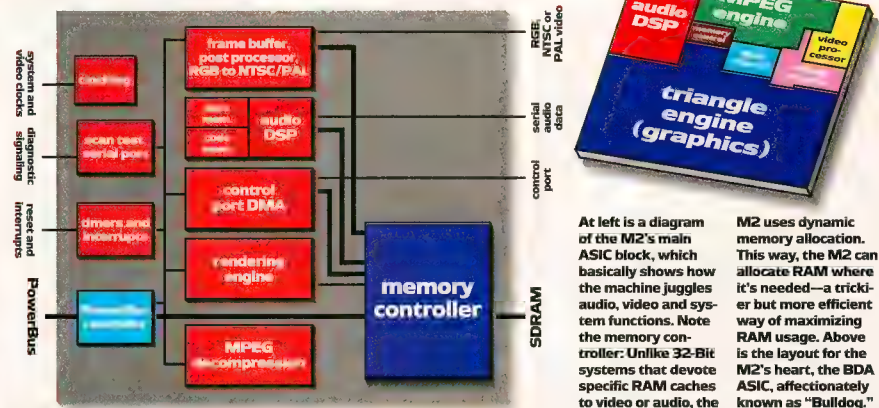

Source: The 3DO Co.

SAY HELLO TO AN OLD FRIEND!



NOW AVAILABLE ON SUPER NINTENDO!

SUPER NINTENDO

Williams 
Williams Entertainment Inc.

MS. PAC-MAN™ ©1992 NAMCO, LTD. ALL RIGHTS RESERVED. MS. PAC-MAN IS A TRADEMARK OF NAMCO, LTD. MANUFACTURED AND SOLD UNDER LICENSE BY NAMCO HOLDING CORP. WILLIAMS IS A REGISTERED TRADEMARK OF WILLIAMS ELECTRONIC GAMES, INC. USED BY PERMISSION. SUPER NES VERSION DEVELOPED BY DIGITAL ECLIPSE SOFTWARE, INC. NINTENDO AND THE SUPER NINTENDO ENTERTAINMENT SYSTEM ARE REGISTERED TRADEMARKS OF NINTENDO OF AMERICA INC. © 1991 NINTENDO OF AMERICA INC.

VIDEO GAME



with hyper-amplified sound & graphics

hyper-amplified

21 watts of
740 mi
aimed right
your

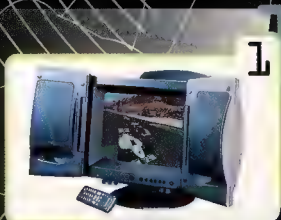

>> power >>

stereo surround sound
and built-in sub woofer



enhanced video graphics

graphics

multiple

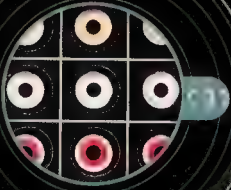

playwi

(play it

...all the time...

video
game
tv
with

sound power
les per hour
ht at
ear drums



hyper-amplified
sound
graphics

stereo < < < <

low emissions 13" color screen

4

5

101-channel stereo tv

101-channel

e open
wide open)



for more info dial
1 800 so simple

YOKOI BIDS FAREWELL TO NINTENDO

Gumpei Yokoi has left the building—Nintendo's corporate offices in Japan to be exact, according to a Nintendo of America spokesperson.

Without a doubt, Nintendo will lose one of its most respected employees in Yokoi. His name may not ring a bell, but his achievements (and his one notable failure) will be instantly familiar to most gamers.

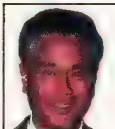

Gumppei Yokoi was the man who led the creation of the Game Boy and Virtual Boy.

As the head of one of Nintendo of Japan's product development teams, Yokoi was responsible for putting the company on the map in terms of portable electronic entertainment. Those products include Nintendo's game watches and, most notably, the Game Boy system, of which Nintendo has sold more than 48 million of since 1989, according to company figures.

While the exact reasons behind Yokoi's departure have not been reported, he has been the target of criticism following the disappointing debut of the Virtual Boy—a project he reportedly kept pushing despite concerns from other company officials about its success. ■

BREAKING

\$199 N64!?!

(Continued from Page 21)

As of press time, neither Sony nor Sega announced any official pricing responses in the wake of N64's \$199 price, although industry analysts predict software price cuts and special system/game bundling deals seem two likely options for Nintendo's hardware competitors.

the numbers game

Also being called into question is Nintendo's statement that only 500,000 N64s would be available for the North American market in the system's first three months. Some gamers contend that an N64 "shortage" predicted by Nintendo is another ploy to boost initial system sales. The view gained a little credence when reports surfaced of Nintendo's pledge to retailers that all presale orders would be filled—suggesting that Nintendo had better confidence in its manufacturing supply than previously assumed. The latest price drop also alludes to better-than-500,000 production. If Nintendo did have only 500,000 available at most, and had confidence that all would sell out (as officials have previously stated), it would make sense to sell them at \$249 rather than \$199.

Still, when contacted to check these production figures, a Nintendo official reiterated that, indeed, only 500,000 units would be available for the N64 North American launch in the first three months—reportedly in batches of 100,000 or 200,000 each month. However, company officials declined to give out exact numbers because it was "proprietary information," according to the spokesperson. It remains to be seen whether these numbers will hold up after the holidays. ■



STAY TUNED

Gamer-dedicated TV packs an impressive audio/visual display

The idea of designing a television especially for video gaming is a notable one, surely. But chances are, most of you already have a TV. So what does Samsung's 13" GXTV have to offer that normal TVs can't?

LGivE got the chance to find out by testing the GXTV with several PlayStation and Saturn games. First off, the GXTV is a full-on game TV, complete with

old-out speakers and a remote control.

At 13", the screen is a tad small but clear enough for two people to sit close to and play. What really sets the GXTV apart, however, is not the video—it's the audio. Not only are the sound controls (bass, treble, etc.) fully user controllable, but the

GXTV has four surround sound, and special video game sound modes. A center line, for a compact TV, this puppy's juiced-up speakers (three, including a subwoofer), are powerful enough to compete with many home stereo systems.

To be honest, most gamers would probably rather spend \$249 on a new video game system than on a new TV. This price is really the only black mark against the GXTV. But if you're a gamer looking to replace a ratty TV, plus a killer speaker system to hook up a portable CD or radio, definitely check out the GXTV before considering plain-Jane TVs. ■

The back of the GXTV sports two RF inputs, two A/V inputs and an additional monitor output A/V jack.



A bit of surprising 64-bit news has emerged from **Interplay**. The company has scrapped plans to bring out Clay Fighter 3 for **Matsushita's** M2, and bring it out for the **Nintendo 64** instead. As in previous titles in this series, Clay Fighter 3 will use clay models to develop character animation. This game also will include new but familiar faces such as Earthworm Jim and Boogerman (actual clay models shown below) as fighters. This is the company's second officially announced N64 title in development. The other title is Ultra Descend, an N64 version of the futuristic PC flight sim.



Here's a few **Sony** PlayStation game facts:
1. What is **Sony's** current biggest-selling PS game worldwide? While **Namco's** Ridge Racer or Tekken seem likely candidates, the honor belongs to ESPN's Xtreme Games.
2. What has been the top best-selling PS game since March? **Capcom** says it's Resident Evil, which has sold more than 1 million units in just six months.

THIS MAN WANTS TO SAVE HUMANITY.



Robotron X.
The Third Dimension Of Excitement.

Robotron X © 1999 Williams Entertainment. All rights reserved. Williams Entertainment, the Robotron X logo, the Robotron X character, and the Robotron X logo are trademarks of Williams Entertainment, Inc. Distributed and sold by Williams Entertainment Inc. Licensed by Sony Computer Entertainment Inc. for use on the PlayStation 2 console. PlayStation and the PlayStation logo are trademarks of Sony Computer Entertainment Inc.



Williams 
Williams Entertainment

HAVING A BALL?

Spacotec, ASCII Set to Unleash New 3-D Control for PlayStation

Whatever the future of video game controllers may be, that future will certainly include the likes of Spacotec IMC's technology.

The company recently inked a deal with ASCII Entertainment to develop a new 3-D game controller for the Sony PlayStation, slated to be released sometime in 1997. No price has yet been set for the controller.

As video games rely more on 3-D environments, ASCII hopes its new controller will "set a new industry standard" for navigating through these virtual worlds. ASCII President Hide Irie stated,

Essentially, ASCII bought the exclusive PlayStation rights to Spacotec's "RealLife 3-D Controller" technology, which has been used in PC game controllers and computer industry tools. ASCII will then design and make the PS controller. In addition, both ASCII and

Spacotec will work with PS game developers to make sure future titles take maximum advantage of the 3-D technology.

Instead of an analog joystick, the PS controller will use a ball for movement, which will provide full simultaneous six-axis, 360-degree movement in any direction. This is key for 3-D games such as Doom. Instead of using the top shift buttons to rotate around, you can just twist the ball one way or another—and move in a certain direction at the same time.

In addition, the analog control boasts up to 1,024 variable speed levels. So in a 3-D exploration game, the control could tell whether a player wanted to creep slowly or sprint, depending on the pressure applied to the ball.

As of press time, Spacotec has not yet licensed its 3-D technology for similar Sega Saturn or Nintendo 64 controllers. ■

How Does This Thing Work?

The ball in the above photo is NOT a trackball; rather, it's a ball-on-a-stick that twists, turns and moves in any direction (see diagram below). The control is analog and very sensitive, so your rate of movement can change depending on how much you twist or push the ball. According to Spacotec IMC, this control will be able to do moves that can't be done with today's controllers. In a 3-D game like Doom, for example, the ball will let you "circle strafe," in which you can circle around a target with your weapon always pointed at the enemy.



A glimpse of the PC pad (left) offered by Spacotec offers a hint of what the PS version could look like.



PRESS **START**



The question of what Sony would do with company-owned **Psygnosis** seems to have been answered—for now, at least. The company, known for bolstering the PlayStation's launch with games such as Destruction Derby and WipeOut, has signed an exclusive distribution deal with Sony for its upcoming 15 PS games. The deal lasts only until March 1997, which fuels speculation that Sony could very well sell its software subsidiary once the agreement expires. As you may know, Sony has contemplated selling **Psygnosis**, which has sought to develop games for multiple platforms—including the Sega Saturn—to increase its profits.

Tetris fans, rejoice! **Blue Planet Software**, the company that decides what publishers will get the license to put out Tetris games for any computer or console, has given **Jaleco** exclusive two-year rights to bring out Tetris games for the Saturn and PlayStation in the United States. The 32-Bit game, Tetris Plus, is due in stores this fall for a retail price of \$49, according to a statement from **Jaleco**.

KA-CHING!



THINK YOU'RE TOO COOL FOR THE POWER RANGERS? WELL, POWER RANGERS ZEO FULL TILT BATTLE PINBALL IS GONNA TURN YOUR HEAD AROUND! WHEN YOU GET A LOAD OF THE 5 EYE-POPPING 3D-MODELED PLAYFIELDS, AWESOME SGI RENDERED CINEMAS AND TEXTURE MAPPED GRAPHICS, YOU WON'T BE ABLE TO KEEP YOUR HANDS OFF THE FLIPPERS. THROW IN SOME SMOKIN' SOUND EFFECTS AND ARCADE-LIKE PLAYABILITY, AND YOU'VE GOT A GAME THAT TAKES COOL TO A WHOLE NEW LEVEL--FULL TILT BATTLE PINBALL!



VISIT THE BANDAI WEBSITE AT
<http://www.bandai.com>

POWER RANGERS ZEO Full Tilt Battle Pinball is licensed by Sony Computer Entertainment for play on the Sony PlayStation. The Sony Computer Entertainment Logo is a trademark of Sony Corporation. PlayStation™ and the PlayStation™ logos are trademarks of Sony Computer Entertainment, Inc. © 1996 Sony Computer Entertainment™ and © 1996 Saban. All Rights Reserved. POWER RANGERS ZEO and all related logos, names and distinctive likenesses therein are the exclusive property of Saban Entertainment, Inc. and Saban Interactions, Inc. Used under license by Bandai America Incorporated. Bandai is a registered trademark of Bandai America Incorporated. Package © 1996 Bandai America Incorporated. 12851 E. 166th Street, Carlsbad, California 92003.

BANDAI

Out here brick walls have 4.5 speed.



And rapid-fire analysis: the most complete game ever. This is the ultimate judge. Catch it.

MADDEN
97

www.easports.com





MIDWAY



SUPER NINTENDO

ENTERTAINMENT

7'0"

6'0"

5'0"

4'0"

3'0"



THE BIGGEST AND BADDEST 16-BIT MK EVER is on the street. 5 new backgrounds. 8 new playable characters including Kitana, Jade, Scorpion

- **N64 Sales Slow In Japan**
- **Super NES SFA2 For XBand?**
- **PS Add-On For Tekken 3?**
- **Enix, Tecmo Join N64 Ranks**
- **Bomberman For PS, N64**
- **Kutaragi's Dino-mite Project**

Trick or treat? my loyal Q-Follower! The Q-Mann is back once again with the latest insider info from the great gaming pumpkin patch! This month's selection of dirt may stain some white shirts, but the real fun begins now...Yours truly has hit the jackpot with some help from a stable of spies so large it could circle the Iron curtain. It seems Square Soft plans on doing Final Fantasy VIII for the Nintendo 64DD after all, with some major "shuttle" diplomacy putting the cogs into motion. While other mags have promoted a split between those at Square and the big "N," the Q has discovered that the real story surrounding Square's release of Final Fantasy VII on the PlayStation stems from the fact that he had to release a version of the game this year to help Square's bottom line, and a version for the Nintendo 64 wouldn't have been ready in time to yield the desired windfall that the title will surely bring. Furthermore, the size and scope of the project on the N64 made carry a prohibitive option (I hear they questioned whether the entire adventure would fit on silicon), and the Disk Drive won't be widely available until 1997...From Terry Aki, our man in the trenches of Tokyo, comes word that sales of Nintendo 64 have slowed down considerably in Japan and early adopters sucked up some 500,000 units in the first week of release. Rumor has it that 10 percent of all Nintendo 64s purchased were returned after gamers had finished Mario. Considering the drought of softs available for the N64, the Q can't blame them. According to leading buff books in Japan, the island couldn't get enough of the Mario Man for the first two weeks after the N64's release: claiming the top spot in both hardware and software categories. The next two weeks, however, have been dominated by...RIGHTS to the Sega Saturn! Now, Sony has retaken the top spot! What's a Nintendo PR agent to do?

Quartermann hears that Nintendo pulled a fast one on the retail community over in Japan by demanding that for each unit of Nintendo 64 hardware purchased, the retailer had to take an equal quantity of Mario 64, PilotWings and a third game. Mario 64 has sold well, but the dino two games are starting to collect dust because customers just aren't as interested...Over in the United States, many third-party developers are balking at Nintendo's exploits, and the fact that the initial cost of goods is \$35 per N64 cartridge isn't helping Nintendo's cause (and that's not even counting development costs). By comparison, third-party developers who make games for Sony have a \$10 cost of goods per unit. In addition, if a company puts a PlayStation game on store shelves and it doesn't sell, some developers don't have to pay the per-game royalty to Sony. True to Nintendo's history, however, the company makes its money via a surcharge to the production, meaning the big N has a revenue stream that is unaffected no matter how a cart performs. It's a great business strategy that, unfortunately, isn't winning a lot of third-party friends.

Some companies are banking on the fact that the N64 will sell through the roof from now until Christmas. Panasonic plans to make the new Bow 64 for Nintendo's big unit while Enix also has plans to release Dragon Quest Gaiden, the next installment of the Dragon Quest series that you might know better as Dragon Warrior...Tecmo is also making a Ninja Gaiden title for the PlayStation which, the Q-Mann understands, could go one of two directions. Tecmo's first option under consideration is to make an entirely new version of the game while the alternate plan is to port over all the previous Ninja Gaiden titles onto one CD with graphics and sound enhancements (sounds kind of like the new Star Wars movies, eh?). The Q is keeping his eye on what is sure to be a blockbuster title, so stay tuned for more details...Sony, meanwhile, seems ready to dominate the gaming market—at least until Nintendo gets more games and systems out their doors. To build on Sony's growth momentum, the lead designer and mastermind of the PlayStation is hard at work on some top-secret software projects. Rumor has it Ken Kutaragi is knee-deep in code with a team of programmers and artists collaborating on software built around the Jurassic Park 2 movie called Lost World...Kutaragi is also rumored to be working hard on design specifications for the PlayStation 2. Sony, comprised out of Japan apparently wants to set the DVD standard with a system that delivers more than just DVD or gaming alone, but a complete multimedia experience. Rumors circulating around Japan suggest the PlayStation 2 will not have the power source included inside the PlayStation unit but will instead use a more traditional A/C adapter as well as on-board memory to relieve the need for expensive memory cards.

As for the PS memory card, some sources within Sony are hinting that the memory cards will become a non-optional element in Sony's marketing efforts. Can you say collectible memory cards? The Q hears of prototypes for game-specific memory cards emblazoned with logos have been floating around the big development area of the PlayStation palace Sony has erected in Northern California and, for one can't wait...Turning to the Panasonic M2 situation, Panasonic has formed a new division specifically to deal with their new (and very expensive) M2 technology. The new division will be called "Panasonic Wonderland" and although details regarding the M2 are becoming clear (the M2 will have a 4x-speed drive and eight megabytes of RAM) the system won't be released in Japan until April '97 and as late as September here in the U.S. In a related story, the Q has tracked down some of the reasons why it purchased the technology for \$100 million and, more importantly, what it intends to do with it. Panasonic wants to put some distance between its DVD player and the rest of the major electronics manufacturers (deja vu?!). Panasonic is talking behind closed doors about releasing a second M2 hardware system with a built-in DVD player for \$399 (deja vu all over again?!). Over in Japan right now 20 M2 games are up and running, although all of the games appear to be original efforts at this point. One of the rare high-profile titles in pipe for the new technology is rumored to be Street Fighter 3 from Capcom. While the Q has yet to pluck any word from the gaming grapevine about any of these 20 titles, Studio SDO is hiring every quality programmer and artist within a stone's throw of Silicon Valley and is rumored to have a minimum of 10 major M2 titles nearing completion. Rumor has it Studio SDO is also working on a couple of PlayStation titles, including a quite mysterious piece of programming called G3.

On some other news, it looks as though Capcom has passed the job of releasing Street Fighter Alpha 2 on the Super Nintendo to Nintendo. Word is that the game will be compatible with the Super Nintendo XB and modem as well. The game should be out in early November, one month after Street Fighter Alpha 2 is released for the Sony PlayStation...Capcom has already started development of Resident Evil 2, and the game may end up packed on two CDs. It's too early to tell, but Capcom won't be reworking the old engine and putting a twot at the end of the game. BE2 will be entirely new and rumor has it we could see some new characters added. Meanwhile, Saturn owners could see the game hit their machine as early as May of next year...Hudson Soft has licensed Bomberman to the PlayStation format with an ETA of sometime early next year. It's not clear whether this will be old versions of Bomberman on one CD or an entirely new Bomberman adventure, but the Q will keep you posted. In more big news on the Bomberman front, Hudson Soft has signed up as a Nintendo 64 licensee, and sources tell me that a fully-rendered Bomberman is on the way to the N64.

Nothing new on the Mortal Kombat IV front this month, but the current rumor running around the Q2 office has it the game hitting the N64 as its first home stop. Nintendo is rumored to have had several closed-door discussions with Williams about bringing out Mortal Kombat IV for the N64 system and this could be the reason that Williams has delayed the release of Doom 64 until April or May of next year. The official company line from Williams indicated that the game was being held back to ensure that Doom 64 would be the best Doom ever. Word on the street also says that the size of the game has gone from 64 to 96 Megabites...Namco and Sony are putting some plans together for Tekken 3. The game will hit the arcades first, then the PlayStation. Or will it? High-level negotiations on the title are in the works, and we'll have more on Tekken 3 next month. Some industry insiders suggest that an entirely new hardware upgrade will be added to the PlayStation in conjunction with this game. Can you say Sony Disk Drive? Why would Sony pursue an optical system when they're already CD-based? Secrets, secrets, secrets...That wraps up this installment of the Q-Mann report my loyal Q-clips. Look for more on Tekken 3, Mortal IV and some big news on a newly developed company with big plans (and big bucks). See you next month.

THE Q

Whether you are playing Street Fighter Alpha 2 in the arcade or at home (on your PlayStation, Saturn or Super NES), you can count on *EGM* to bring you every move



and combo. You'll recognize many of these moves from previous SF2s, but this game packs many brand-new attacks, as well. Here is a partial list for the popular characters in the game. Practice the moves at home, then show them off at the arcade.

RYU

- Overhead
 Fireball
 Fake Fireball
 Dragon Punch
 Hurricane Kick
 Combo 1: Shinkuu Hadoken
 Combo 2: Vacuum Hurricane Kick
- F + **Strong Punch**
 D, DF, F + **Punch**
 D, DF, F + **Short Kick**
 F, D, DF + **Punch**
 D, DB, B + **Kick**
 D, DF, F, D, DF, F + **Punch**
 D, DB, B, D, DB, B + **Kick**

CHARLIE

- Overhead
 Thrust Kick
 Sonic Boom
 Somersault Kick
 Combo 1: Sonic Blade
 Combo 2: Somersault Justice
 Combo 3: Crossfire Blitz
- B + **Forward Kick**
 F + **Roundhouse Kick**
 Charge B, F + **Punch**
 Charge D, U + **Kick**
 Charge B, F, B, F + **Punch**
 DB, DF, DB, UF + **Kick**
 Charge B, F, B, F + **Kick**

CHUN-LI

- Knee Flip
 Kikoken
 Spinning Kick
 Split Kick
 Combo 1: Thousand Burst Kick
 Combo 2: Mega Kikoken
 Combo 3: Mega Spinning Kick
- DF + **Roundhouse Kick**
 D, DF, F + **Punch**
 Charge D, U + **Kick**
 D, DB, B + **Kick**
 Charge B, F, B, F + **Kick**
 D, DF, F, D, DF, F + **Punch**
 Charge DB, DF, DB, UF + **Kick**

ADON

- Overhead
 Jaguar Kick
 Jaguar Knee
 Jaguar Tooth
 Super Combo 1: Jaguar Elbows
 Super Combo 2: Multiple Jaguar Kicks
- F + **Strong Punch**
 D, DF, F + **Kick**
 F, D, DF + **Kick**
 F, DF, D, DB, B + **Kick**
 D, DF, F, D, DF, F + **Punch**
 D, DB, B, D, DB, B + **Kick**

GUY

Chain Combo	Jab, Strong, Fierce, Roundhouse
Overhead	F + Strong
Spin Kick	D, DB, B + Kick
Spin Elbow	D, DB, B + Punch
Bushido Run	D, DF, F + Kick
Bushido Leap	D, DF, F + Punch
Combo 1: Bushido Rampage	D, DF, F, D, DF, F + Kick
Combo 2: Rising Punches & Kicks	D, DF, F, D, DF, F + Kick

KEN

Overhead	F + Forward Kick
Krazy Kick	F + Roundhouse Kick
Fireball	D, DF, F + Punch
Dragon Punch	F, D, DF + Punch
Hurricane Kick	D, DB, B + Kick
Fake Hurricane Kick	D, DF, F + Short Kick
Combo 1: Shoryureppa	D, DF, F, D, DF, F + Punch
Combo 2: Shinryuken	D, DF, F, D, DF, F + Kick

AKUMA

Overhead	F + Strong Punch	Hurricane Kick	D, DB, B + Kick
Dive Kick	D + Forward Kick (in the air)	Teleport 1	F, D, DF + All Punch or All Kick
Fireball	D, DF, F + Punch	Teleport 2	B, D, DB + All Punch or All Kick
Red Fireball	D, DB, B + Punch	Super Combo 1: Shoryureppa	D, DF, F, D, DF, F + Punch
Air Fireball	D, DF, F + Punch (in the air)	Super Combo 2: (Air) Shinkuu Hadoken	D, DF, F, D, DF, F + Punch
Dragon Punch	F, D, DF + Punch		

SODOM

Jitte Strike	D, DF, F + Punch
Power Bomb	B, DB, D, DF, F, UF + Punch
Carpet Drop	B, DB, D, DF, F, UF + Kick
Combo 1: Mega Power Bomb	B, DB, D, DF, F, UF, U, UB, B, DB, D, DF, F + Punch
Combo 2: Mega Jitte Strike	D, DF, F, D, DF, F + Punch

ROSE

Soul Spark	B, DB, D, DF, F + Punch
Soul Reflect	D, DB, B + Punch
Soul Fist	F, D, DF + Punch
Soul Thrust	D, DB, B + Kick

9 OUT OF 10
PSYCHOLOGISTS

ReCOMMEND

LOADED

FOR PATIENTS WITH A
SEVERE CASE OF
ITCHY TRIGGER
FINGER

BUTCH

GOES TO
THE
DENTIST TO
RECEIVE
LOADED

NO MORE
RUNNING OUT
OF AMMO.

GET
LOADED

What Good is a Sega Saturn™

if it isn't **LOADED?**



FWANK
WUZ
HERE

I AM
NOT A
ROLE
MODEL!

When you wake up
in PRISON framed by
some FAT
UGLY Boy
and the GROUND
ripples beneath your
feet - you're not
DRUNK or F%@ED up
on DRUGS - you're
LOADED

FORGIVE
ME
FATHER
FOR I HAVE
SINNED
LOADED



BY GAMERS. FOR GAMERS.
Also Available
on PlayStation™
Game Console



MATURE



AGES 17+

©1995 Gremlin Interactive, Ltd. MCPS. All rights reserved. Loaded and Interplay are trademarks of Interplay Productions. All rights reserved. Exclusively published and distributed by Interplay, licensed from and developed by Gremlin Interactive, Ltd. Sega and Sega Saturn are trademarks of SEGA ENTERPRISES, LTD. All rights reserved. PlayStation™ and the PlayStation logo are trademarks of Sony Computer Entertainment, Inc. All rights reserved. All other trademarks are the property of their respective owners.



"This game does not

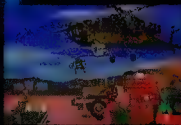

Area 51 ©1995 Atari Games Corporation. All rights reserved. Developed by Mass Logic, Inc. Distributed under license by Williams Entertainment Inc. Williams is a registered trademark of Williams Electronics Games, Inc. Licensed by Sega Enterprises, Ltd. for play on the Sega Saturn™ System.

According to the government it is preposterous to believe that such a game as AREA 51 exists. Concerning allegations of a top secret experiment gone bad, resulting in mutating alien creatures, authorities were unavailable for comment. An identified source states AREA 51 has developed advanced technologies of mysterious nature: 3D rendered graphics, live digitized action and stop frame animation. All have been denied by high level officials. As for a home invasion of the #1 ARCADE GAME, the Pentagon asserts there is absolutely no documentation pertaining to this rumor.

CONFIDENTIAL

exist.”



You can't get in but you can take it home.



Sega and Sega Saturn are trademarks of Sega Enterprises, Ltd. All rights reserved. Licensed by Sony Computer Entertainment. Available for use with the PlayStation game console. PlayStation and the PlayStation logo are trademarks of Sony Computer Entertainment, Inc.

PROTOS

RE-LOADED

NEXT WAVE



After what seems like an incredibly long wait, the sequel to one of the most popular PlayStation games is getting ready for release.

Re-Loaded is the sequel to Interplay's popular blast-fest, *Loaded*. Re-Loaded retains the action- (and violence) packed excitement of the original, as well as adding the elements of adventure and strategy. A new three-fourths perspective gives players a better view of the action.

All the characters from the original return (except for Vox), as well as some new characters. The strangest of the newbies is a cybernetic nun who makes a "habit" of causing pain.



SYSTEM	RELEASE DATE
 PlayStation	December
PUBLISHER	THEME
Interplay	Action
PLAYERS	SIZE
1 or 2	CD-ROM
	% DONE
	30%



Since his introduction to the video game scene, Mega Man has appeared on nearly every single platform out there. Now he's all set to make his debut on an U.S. 32-Bit system. In *Mega Man 8*, Dr. Wily is once again planning to take over the Earth with a new army of evil robots.

As in the earlier games, Mega Man's faithful robo-dog, Rush, is there to lend him a paw. Rush is now able to convert into a jet bike, form a protective shield around Mega Man and even recharge Mega Man's weapon and energy levels.

Thanks to the vast storage space of the CD, *Mega Man 8* will feature a ton of frames for each character, delivering cartoon-quality animation. Mega Man fanatics can also look forward to fully animated anime sequences in the intro and throughout the game.



MEGAMAN 8

SYSTEM	RELEASE DATE
 PlayStation	1st Qtr. '97
PUBLISHER	THEME
Capcom	Action
PLAYERS	SIZE
1	CD-ROM
	% DONE
	10%

WILD 9™

REMEMBER US? WE BROUGHT YOU EARTHWORM JIM. RIGHT NOW
WE ARE MAKING OUR FIRST GAME FOR 32-BIT SYSTEMS.

WE'VE PUT THE BEST GAME MAKERS AROUND THE WORLD IN
THE SAME ROOM. SOMETHING BIG IS BEGINNING TO HAPPEN...

MORE LATER.
THE SHINY TEAM



PROTOS



NECRODOME

For some reason, in the future, normal sports fail to entertain the human race anymore. That's why future societies created sports like Necrodome.

In Necrodome (it's just a game, not an actual death-oriented sport from mankind's dark future), you race your heavily armed car through 15 different tracks, blasting other racers and trying to earn the right to race in the Necrodome.

Unique to Necrodome is the ability for two players to play in a Cooperative Mode. One player controls the car, while the other player mans the gun turret.



NEXT WAVE

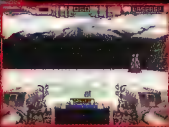

PUBLISHER	SYSTEM	THEME
Mindscape		Sports/Action
RELEASE DATE	PLAYERS	SIZE % COMPLETE
October	1	CD-ROM N/A

TOBAL #1



Now this is a little strange. Square, the company behind the incredible Final Fantasy series, is making their first PlayStation game a 3-D fighter, not an RPG.

In Tobal #1, you will be given complete freedom of movement to attack your opponent from all directions.

Perhaps the nicest aspect of the game is the character design. All the fighters were designed by Akira Toriyama, the artistic genius behind the Dragonball series and the characters in the Super NES RPG hit, Chrono Trigger.



Ultimate MK

3

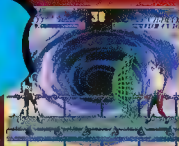

PUBLISHER	SYSTEM	THEME
Williams	32-BIT	Fighting
RELEASE DATE	PLAYERS	SIZE % COMPLETE
October	1 or 2	32-Meg N/A

Prepare yourself for what may be the final Mortal Kombat game on 16-Bit systems. Ultimate Mortal Kombat 3 will soon be coming to both of the 16-Bitters.

UMK3 contains all of the characters from MK3, but also adds a few new ones, such as Rain, the mysterious new ninja. Look for the return of old favorites as well, like Scorpion and the elusive human Smoke. In addition, UMK3 sports new backgrounds, new codes and new secrets to discover.



PUBLISHER	SYSTEM	THEME
Sony		Fighting
RELEASE DATE	PLAYERS	SIZE % COMPLETE
November	1 or 2	CD-ROM 70%

Go for a spin. Or burn up the road.



There are two kinds of people in the world. Those who wear pink. Those who wear black. If you're in the second category, you know other racing games just aren't up to speed. So hit the Burning Road.



Four kick ass vehicles scream over three savage tracks. Wipe-out weather conditions rock your world. Choice of automatic or manual transmission puts you in control—while ample opportunities to **siam** or **slammed** hurt you out of it. From there on in, your performance is not a pretty picture. Especially when you consider all the **visible damage** left behind, **loss blazing arcade quality action** and **4 distinct camera angles** into the mix for the ultimate roadkill recipe. And unlike those other games where you may never know what hit you, Burning Road's **entire replay mode** plays the whole race start to finish—not just lap highlights.



So trash the tutu and strap on a helmet. Because with Burning Road, you're an accident waiting to happen...but not for long.

<http://www.playmatestoys.com>



ESRB Rating: ESRB Rating: Everyone 10+

1-800-955-2200



BURNING ROAD

Exclusively for PlayStation game console

Get Damaged.



PROTOS



One of the hottest racing games to hit the arcade will be making a welcome appearance on the N64 this fall. Racing enthusiasts who fell in love with the game's original feel need not worry about the port over to the new and yet untested system. The graphics, as you can see from the few preliminary shots we received, are extremely crisp—giving bright skylines and opposing racers crisp, sharp detail. The original cars also still hold a close resemblance to the fleet gamers have grown used to. The stages also appear to be close to original translation, bearing testimony to the N64's ability to handle high-quality arcade ports. The only question that remains for gamers is: How many hidden vehicles are there, and is the hilarious schoolbus still one of them? A great game that will work wonders for the N64's post-launch period.

SYSTEM	RELEASE DATE
NINTENDO 64	October
THEME	
Racing	
PUBLISHER	
Nintendo	64-Meg
SIZE	
PLAYERS	
1 or 2	N/A



CRUISE 'N' USA

NEXT WAVE

SHADOAN

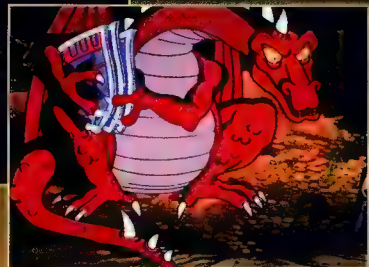

From the minds that brought players Dragon's Lair and Brain Dead 13 comes their latest point-and-click title, Shadoan. With a budget of more than \$3 million, ReadySoft really pulled out all the stops to get this one on the shelves before Christmas. More than 300 animators worked furiously for nine months to get this one developed. About 70,000 hand-painted cells of animation later, the title proves the abilities of the workers. The graphics look extremely clean and, like most of ReadySoft's titles, appear to be something of a cartoon more than a video game. ReadySoft, in the past years, has created a niche for themselves that is only gaining momentum.

PUBLISHER		SYSTEM	THEME	
ReadySoft		PlayStation	Adventure	
RELEASE DATE	PLAYERS		SIZE	% COMPLETE
November	1	CD-ROM	N/A	

DUKE MAY ROCK BUT RAMSES RULES.

POWER SLAVE

COMING IN NOVEMBER.

[HTTP://WWW.PLAYMATESTOYS.COM](http://www.playmatestoys.com)



SEGA SATURN
PC CD-ROM

For Windows 3.1 or Windows 95.



This official seal is your assurance that this product meets the highest quality standards of SEGA's top game and accessories. We'll see that they are compatible with your SEGA system.



16200 Trojan Way
La Mirada, CA 90638
(714) 562-4743

POWER SLAVE is a trademark of Lobotomy Software. All rights reserved. Playmates Interactive Entertainment, Inc. Authorized User. Windows 95 is a registered trademark of Microsoft Corporation. Sega, Genesis and Sega Saturn is a trademark of Sega Enterprises Ltd. All Rights Reserved. PlayStation and the PlayStation logos are trademarks of Sony Computer Entertainment Inc. PIE is a trademark of Playmates Interactive Entertainment.

WIPEOUT XL



The game with roots in the Nintendo classic F-Zero brings gamers the second version of its intense futuristic race action. WipeOut XL for the PlayStation seems to be a close re-creation of the original with new and updated tracks. The size and action in the stages seems, again, very close. Players can probably expect new and better weapons to use on the enemies as well as more intense challenges. No matter what is new, the thrill of playing WipeOut XL is in the tracks and the skill required to get through those hairpin turns with the confidence of a seasoned professional. Even if nothing has changed except the track challenge, there is still plenty of gameplay to absorb and the same number of players as the original. Players need to wait patiently for its arrival late this fall. More info as it becomes available closer to the release date.

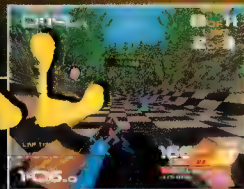

NEXT WAVE

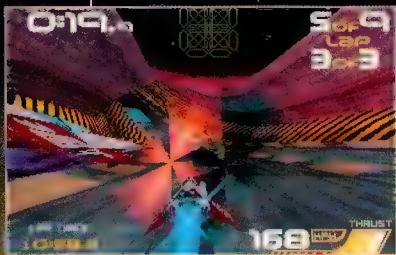

SYSTEM	RELEASE DATE
	October
PlayStation	Theme
PUBLISHER	Racing
Psygnosis	SIZE
PLAYERS	CD-ROM
1 or 2	% DONE
	N/A

PROTOS

WILD 9

NEXT WAVE

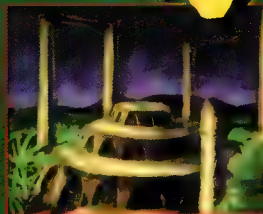

SYSTEM		RELEASE DATE	
PlayStation		2nd Qtr. '97	
PUBLISHER		THEME	
Interplay		Adventure	
PLAYERS		SIZE	
1		CD-ROM	
		% DONE	
		N/A	

This graphically impressive game has a clean look and bears testimony to the ability of the PlayStation. Even though this one is still in the beginning of the development process, we did manage to get a few screens of the eye-catching title. Gameplay seems similar to the Out Of This World-style of games with the player controlling the character's action from that same vantage point. The story is based on a group of nine teenagers exploring and attempting to use their youth to take over the galaxy. The title's story is tangled in surprises and twists of fate throughout the adventure.

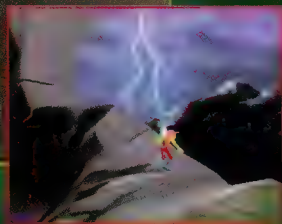
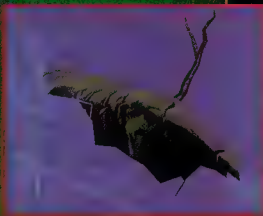

Herc's Adventures



Greek mythology is turned into a virtual toga party as three mighty mortals go to hell and back to save a goddess and the cradle of civilization. In LucasArts' latest title, Herc's Adventures, players get the chance to explore over 40 unique worlds of action and adventure. There are three different mortal heroes to choose from, each with his/her own specialized weapons, strengths and powers. Either in One- or Two-player Split Screen, players control their hero and watch him/her grow as they guide him/her successfully through the levels. There are opportunities for your character to grow stronger and become faster and smarter. It's a game obviously designed for the long term and not just a one-night stand.

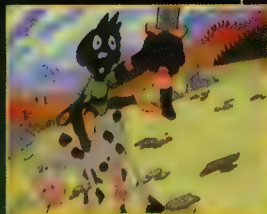

PUBLISHER		SYSTEM		THEME	
LucasArts		PlayStation		Adventure	
RELEASE DATE		PLAYERS		SIZE	
January		1 or 2		CD-ROM	
				% COMPLETE	
				N/A	

CLEANLINESS IS
NEXT TO GODLINESS.

<http://www.playmatestoy.com>

VMX RACING



SEGA

SEGA Saturn



16200 Trojan Way
La Mirada, CA 90638
(714) 562-1743

VMX racing developed by Studio E. © 1996 Sega. E. All rights reserved. Studio E and the Studio E logo are trademarks of Studio E. Sega, Genesis and Sega Saturn are trademarks of Sega Enterprises, Ltd. All Rights Reserved. PlayStation and the PlayStation logo are trademarks of Sony Computer Entertainment Inc. PIE is a trademark of Playmate's Interactive Entertainment.

DOWN in the DUMPS

NEXT WAVE



Billed as one of the most beautiful adventure games to ever grace a home system, *Down in the Dumps* really attempts to live up to a high standard. The title features a high concept and a wildly funny plot for players to enjoy as they control the amazingly rendered characters. *DitD* attempts to clone a rendered cartoon and incorporate player-controlled action into the plot. Depending on the difficulty level and the maturity of content, *DitD* may be the best possible title for younger players to try. With grossly proportioned characters and beautifully rendered backgrounds, this title, even in this early level of development, has much of what is required to make it a hit.

SYSTEM	RELEASE DATE
 PlayStation	1st Qtr. '97
THEME	
Adventure	
PUBLISHER	SIZE
Philips	CD-ROM
PLAYERS	% DONE
1	N/A



The NFL, the whole NFL

"Acclaim's developers have gone the extra nine yards to make this the football game to have."

-VideoGames, June 1996

"Some of the finest graphics for any sports title... It looks like we may have another Monster of the Gridiron!"

-VideoGames, June 1996



OFFICIALLY LICENSED PRODUCT OF



Acclaim
entertainment, inc.

www.acclaimnation.com



UNIFORM #S, HELMET LOGOS AND NAMEPLATES



OVER 500 NEW PLAYS



WEATHER AFFECTS GAMEPLAY

PROTOS

MAJOR DAMAGE

NEXT WAVE

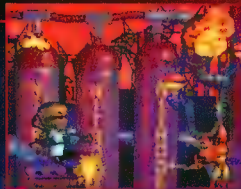

Normally, you wouldn't want any harm to come to your PlayStation or Saturn, but Capcom is getting ready to subject it to Major Damage. Don't worry, though, your warranty will still be valid. Major Damage is the name of Capcom's newest adventure shooter game.

You control Major Damage in this 16-level blast-a-thon which features six implements of destruction that can be fired in 16 directions. You will fend off enemies coming at you from either side as well as from the background. In such a case, you can turn and fire into the screen, taking out the enemies plus anything else that happens to be there. To aid him in his battles, Major Damage can also hop into the Damagemobile or the Carnage Cruiser to experience some high-speed destruction.

All the game's characters were created with Silicon Graphics workstations, and even one features Digital Image Designs' new Monkey technology that allows his/her 3-D animations to look even more realistic.

SYSTEM	RELEASE DATE
 PlayStation	1st Qtr. '97
PUBLISHER	THEME
Capcom	Shooter
PLAYERS	SIZE
1	CD-ROM
	% DONE
	10%

REV LIMIT

PUBLISHER		SYSTEM	THEME	
Seta		NINTENDO 64	Racing	
RELEASE DATE	PLAYERS		SIZE	% COMPLETE
1st Qtr. '97	N/A		64-Meg	N/A



It seems that with every new system nowadays, there comes a slew of racing titles. The Nintendo 64 is no exception. First there was Cruis'n USA, and now we have Rev Limit.

Rev Limit looks like a major jump over Cruis'n. As you can see, the graphics are a sight to behold. They look incredibly smooth and startlingly real.

It is set up like most racing games, with a map of the track on the screen and all the gauges visible. Like many other racers, you need to reach checkpoints in a certain amount of time to continue racing.

While it may not be the most original racing game out there, Rev Limit seems like it will be more than qualified to be the number-one racing game for the Nintendo 64.



INTERNATIONAL PROTOS

SUDDENLY, THINGS ARE GETTING PERSONAL.

Now, it's your reputation on the line. And time to leave your mark in this perfect translation of the #1 arcade phenomenon. On your side is the innovative custom combo system, now allowing you to link together your own series of brutal attacks. You'll need every possible advantage to take on a total of 18 fighters, the most ever in Street Fighter legend. Remember, hesitation is deadly. Because in the end, it's all about who's the last one left standing.



CAPCOM



© 1997 CAPCOM CO., LTD. ALL RIGHTS RESERVED. STREET FIGHTER ALPHA 2 is a trademark of CAPCOM CO., LTD. in Japan and other countries. CAPCOM, the CAPCOM logo, and the names of CAPCOM CO., LTD., Street Fighter and the PlayStation logo are trademarks of CAPCOM CO., LTD. in Japan and other countries. Sega Saturn and the Saturn logo are trademarks of Sega Enterprises, Ltd. in Japan and other countries.



THEY'RE NOT LIKE EVERYONE ELSE. THEY CAN DO THINGS MOST PLAYERS CAN'T. AND THEY'RE EVERY RED-SHIRT, WALK-ON FRESHMAN'S WORST NIGHTMARE. YOUR ASSIGNMENT IS SIMPLE. STOP THEM. ☉ WELCOME TO NCAA® GAMEBREAKER™; RUDY. WITH REAL BOWL GAMES, REAL STADIUMS, REAL TEAMS, EVEN REAL FIGHT SONGS. YOU CAN PLAY ALL 111 DIVISION I-A TEAMS, THE TOP I-AA TEAMS AND SOME OF THE GREAT TEAMS OF THE PAST. YOU CAN CALL REAL COLLEGE FORMATIONS LIKE THE FAMED WISHBONE AND RUN THE OPTION AS IT WAS MEANT TO BE RUN, PITCHING THE BALL RIGHT UP TO THE NANOSECOND BEFORE YOU GET CLOCKED. THERE'S ALSO STAT TRACKING FOR THE ENTIRE SEASON AND A HEISMAN TROPHY RACE. ☉ THERE'S AN NCAA® GAMEBREAKER NATIONAL CHAMPIONSHIP TOURNAMENT WHICH UNQUESTIONABLY DETERMINES THE NATIONAL CHAMPION. PLUS UNLIMITED CAMERA ANGLES SO YOU CAN GET THE ABSOLUTE BEST VIEW OF YOUR OPPONENT RUNNING BACK ONE OF YOUR KICKOFFS. CLASSES BEGIN SOON. BE PREPARED FOR YOUR FIRST LESSON.



“I’M TAKING THIS BALL DIRECTLY



INTO THE END ZONE. WHO WANTS A RIDE?™

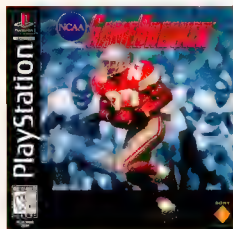

"You **FIGHT** like a **GIRL**"

Just became
THE
ULTIMATE
COMPLIMENT

Virtua
Fighter
PC



"...one of the best fighters for a PC."
- Computer Player

Get ready for all eight original characters to rumble across your desktop
in high-speed, real-time 3D, with no acceleration required. Blazing, fast twitch
response and polygon texture-mapped graphics give you complete mastery
of over 700 moves and combinations. Put your
skills to the supreme test in the ultimate martial
arts tournament. It's your fighter, the number one
3D arcade fighting game, now enhanced for your PC.
It's available on Windows® 9x and it's only from
Sega Entertainment.

(888) SEGA-SaLEs

<http://www.sega.com/segapc/>

TRADE-IN

Trade-in your PC CD-ROM
arcade fighter and get
\$8.00 off
the purchase of Virtua Fighter PC.

Expires 10/31/96. Details on our website
and inside package.

Sega is registered in the U.S. Patent of Trademark Office. Sega Entertainment and Virtua
Fighter are trademarks of SEGA. Microsoft and Windows® 9x are trademarks of Micro-
Corporation. ©1996 SEGA, P.O. Box 8097, Redwood City, CA 94063. All rights reserved.

NEXT WAVE

WILD Choppers

As one of the first military action titles for the Nintendo 64, Wild Choppers looks like it will be able to compete with (and possibly surpass) the king of the flying shooters, WarHawk for the PlayStation.

In Wild Choppers, you control a helicopter flying through many different 3-D polygon worlds, laying waste to enemy troops and vehicles. You have a variety of weapons to choose from to use as your instruments of terror.

With the N64 being so new, this is one of the first types of this game for the system. It certainly looks like it will be worth the wait.

INTERNATIONAL PROTONS

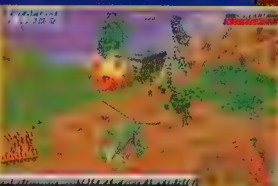

PUBLISHER		SYSTEM	THEME	
Seta		NINTENDO64	Simulation	
RELEASE DATE	PLAYERS		SIZE	% COMPLETE
1st Qtr. '97	N/A		64-Meg	N/A

TIGER SHARK

Tiger Shark for the PlayStation is an action-packed underwater shooter where you pilot a fast-moving sub armed to the gills with weaponry. One of the original features of Tiger Shark is the fact that in addition to fighting underwater, you can surface and take on enemies that float on the surface.

Think of it as a cross between Aquanaut's Holiday and WarHawk. You will be underwater, just swimming around searching for the enemy subs, when you'll spy the underside of a ship floating up above you. You can either attack from below, firing missiles upward at it, or go above water and attack from head-on.

It's a very cool concept that has great graphics to back up the fun. *Maybe this will lead to an Incredible Mr. Limpet game.*

PUBLISHER		SYSTEM	THEME	
GT Interactive			Simulation	
RELEASE DATE	PLAYERS	PlayStation	SIZE	% COMPLETE
1st Qtr. '97	1		CD-ROM	65%



SEGA[®]
Entertainment
Games PCs Play

PROTOS

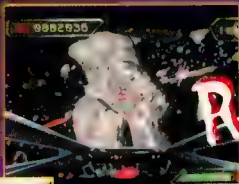

Rebel Assault 2

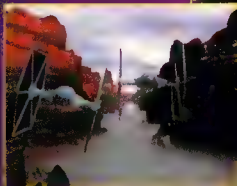

While we all anxiously await the *Star Wars Trilogy Special Edition* and the new trilogy, we will be able to tide ourselves over with *Rebel Assault 2* for the PlayStation.

RAII features the first original *Star Wars* footage filmed since *Return of the Jedi*, which makes it seem like you are actually in a *Star Wars* movie.

You'll be able to pilot X-Wings, Y-Wings, B-Wings, speeder bikes and even a Millennium Falcon class transport, as you take on the Empire, which has created another major threat to the Rebel Alliance.

SYSTEM	RELEASE DATE
 PlayStation	November
THEME	
Simulation	
PUBLISHER	SIZE
LucasArts	CD-ROM
PLAYERS	% DONE
1	N/A

NEXT WAVE

BROKEN HELIX

Konami is going to be giving us their take on the first-person shooter genre soon. *Broken Helix* is a futuristic action game where the player runs through a futuristic world collecting weapons and trying to survive.

Maybe not all too original, but Konami can make it happen.



PUBLISHER	SYSTEM	THEME
Konami	 PlayStation	First-Person Shooter
RELEASE DATE	PLAYERS	SIZE
December	1	CD-ROM
		% COMPLETE
		N/A

Ball Blazer



Ball Blazer is LucasArt's latest arena combat title based on the 1985 original title that appeared on the C64 and the Atari. It incorporates some seriously fast action improved on over the original by leaps and bounds. It supports multiple players in a realtime 3-D environment. The goals of this updated version are the same as before: forcing the player to give everything they have trying to place the fiery ball in the opponent's goal.



PUBLISHER	SYSTEM	THEME
LucasArts	 PlayStation	Arena Combat
RELEASE DATE	PLAYERS	SIZE
January	1 or 2	CD-ROM
		% COMPLETE
		N/A



Champions

REAL RACE CAR DRIVERS DON'T USE JOYSTICKS...NEITHER SHOULD YOU!

Racing with a joystick...is like trying to win a Formula 1 race with a flat tire!...Grab hold of the most professional and affordably priced racing wheel in the world. Let the Per4mer™ Turbo Wheel take you to the finish line of Grand Prix, NASCAR and the Indy 500. Experience the racing sensation of real race car drivers by accelerating and braking with the accuracy of Platinum Sound™ foot pedals. This will give you the ultimate driving experience...*Virtual racing from the #1 Per4mer™ in the industry.*

The Per4mer™ is compatible with all racing software and is available for every gaming platform: Sega, IBM PC, Nintendo SNES, Nintendo 64 and the Sony PlayStation.



AVAILABLE AT: BEST BUY, COMP USA, SOFTWARE ETC, BABBAGES, EGGHEAD SOFTWARE, SUN TV & APPLIANCES, ELECTRONIC BOUTIQUE, KAY BEE TOYS AND OTHER LEADING RETAILERS.

For more information call 1-800-408-4084

FINAL

DOOM

NEXT WAVE



The granddaddy of all first-person shooters is winding down. Williams will soon be releasing the last installment of the Doom series on the PlayStation.

Final Doom is the closing chapter of the Doom trilogy. The original Doom for the PlayStation actually contained the first two games.

This time around, there are no new weapons or enemies, just a series of masterfully designed maps filled with countless traps and even more secrets for the aspiring Doom addict to find.

Those of you who enjoyed the original will love Final Doom. Like the original, it is especially fun playing Deathmatch with another linked PlayStation against a human opponent.

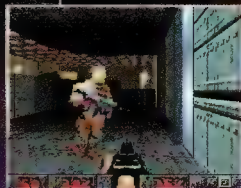

PUBLISHER		SYSTEM	THEME	
Williams		 PlayStation	First-Person Shooter	
RELEASE DATE	PLAYERS		SIZE	% COMPLETE
October	1	CD-ROM	N/A	

PROTOS

WARHAMMER SHADOW OF THE HORNERD RAT

NEXT WAVE

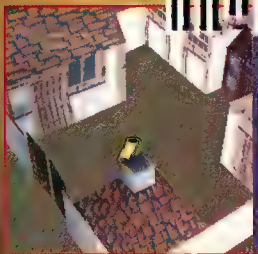

Warhammer: Shadow of the Horned Rat is one of the most intriguing games to be seen in a long time. The action is played in a realistic 3-D environment filled with hills, houses and other old-time buildings. The goal is to command your brigades of fighters from a god view and direct their actions against the hoards of invading marauders. Warhammer boasts thousands of rendered sprites which are viewable from eight different directions. Your quest is to fight against overwhelming forces in an attempt to declare your dominance over the land. Only players with bold leadership abilities, and those capable of mastering intense strategic placement of troops, should attempt this game. One important element Warhammer: SOTHR is not missing is challenge. But are you up to it?

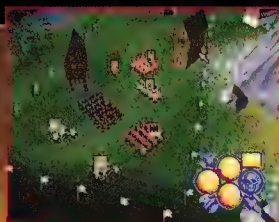

SYSTEM	RELEASE DATE
PlayStation	November
PUBLISHER	THEME
Mindscape	War Sim
PLAYERS	SIZE
1	CD-ROM
	% DONE
	N/A

INTERNATIONAL PRINCE Seta Open Golf



The fist sign of a golf game for the N64, Seta Open Golf looks really sharp. Not much is known about the title at this time, so golf enthusiasts will have to wait to see if it will put the power of the N64 to the test.



PUBLISHER	SYSTEM	THEME
Seta	NINTENDO64	Golf
RELEASE DATE	PLAYERS	SIZE % COMPLETE
1st Qtr. '97	N/A	64-Meg N/A

PUBLISHER	SYSTEM	THEME
Capcom		Action
RELEASE DATE	PLAYERS	SIZE % COMPLETE
2nd Qtr. '97	1	CD-ROM 5%

Capcom's latest production enters the market with a thirst for flesh. Werewolf features three-fourths perspective action where you control a metamorphed human in a variety of settings that incorporate city streets, civilians and other disformed creatures. There are a variety of characters to choose from as well as a broad inventory of weapons and items.



Werewolf

PROTOS



NEXT WAVE

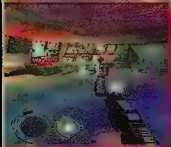

Hold on to your hats kids, there is another first-person perspective shooter coming to the PlayStation. While that's nothing new, this one is by Psychosis, so you know it's bound to be good.

You play Tenka, who is out to stop a giant corporation from producing an army of evil bionoids. Your only weapons are a prototype warfare package named ZENITH and a "self-generating polymorphic gun." Sure sounds funny, but it's quite powerful. Instead of having multiple weapons, you now have one gun that can be upgraded into nine different forms.

Tenka features 20 different environments with motion-captured polygon enemies running at 30 FPS.

This should be one of the better first-person games available.



TENKA

PUBLISHER		SYSTEM		THEME	
Psychosis				First-Person Shooter	
RELEASE DATE	PLAYERS	SIZE	% COMPLETE		
2nd Qtr '97	1	CD-ROM	N/A		

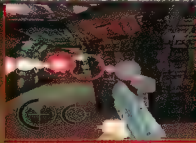

NICE PUNCH.

Unfortunately, he has an iron jaw (and a rocket launcher).

Welcome to

ROBO PIT



- ▶ **Build your own custom robot!**
- ▶ **Hundreds of deadly weapon combinations!**
- ▶ **Over 100 robotic killers to challenge you!**
- ▶ **Intense split-screen mode for 2-Player head-to-head battle!**

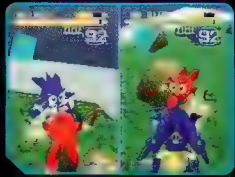

Visit your local retailer or call: **1-818-875-5728 FOR ORDERS ONLY.**
For game tips on our products, call: **1-900-370-NINT**
\$4.99/m. Incentive \$1.99/m. Use with Sega PPT. Must be 18 years of age or have parental permission. Touch-tone phone required.



PlayStation and PlayStation logos are trademarks of Sony Computer Entertainment Inc. Sega and Sega Saturn are trademarks of Sega Enterprises, Ltd. © 1997 1998 Altron Corporation. All rights reserved. KOKOPELLI digital studios is a trademark of T-HO, Inc.

At 248 miles per hour,
not even fear can catch you.



And intimidate waits the same way Andreotti does. With pure grit. This is the ultimate edge.

Andreotti
RACING

www.easports.com



EA GAMES is a trademark of Sega Entertainment, Ltd.
Features vary among platforms. Blow doors.



Andreotti



REVIEW CREW

The Review Crew rates each game in several categories: visuals, sound, ingenuity and replay value. The averages of the four members' scores are listed at the bottom of the reviews. These averages are independent of the overall scores, which are displayed behind each review and based on how the games compare to other titles on the same system.

THE RATING SCALE:

- | | |
|----------------------|-------------------|
| 10-Perfection | 5-Average |
| 9-Virtually flawless | 4-Rent first |
| 8-Splendid | 3-Time-waster |
| 7-Worthy | 2-Don't even rent |
| 6-Good, not great | 1-Flush it |



SHAWN SMITH

CURRENT FAVORITES:

Blast Chamber
Twisted Metal 2
Hardcore 4x4

Shawn's been watching the guys play Tetris Attack 24 hours a day. Because of this, his head has gotten a bit large—kind of gross really. He's been playing more Blast Chamber instead.



DAN ESU

CURRENT FAVORITES:

Tetris Attack
Twisted Metal 2
Tetris Plus

Hsu's been sent to an asylum. It seems he's been seeing Tetris Attack and Tetris Plus pieces everywhere he goes: tile floors, brick walls, etc. When he gets out, he should be okay to work again.



CRISPIN BOYER

CURRENT FAVORITES:

Beyond the Beyond
Tecmo's Deception
Kings Field 2

Cris has started counting the days—or, rather, months—until F77 hits the States. He thinks it's a bit unfair for Square to tease us with screenshots when we have to wait a year to play the game.



SUSHI X

CURRENT FAVORITES:

SF Alpha 2
Tomb Raider
Three Dirty Dwarves

Sushi has been sneaking around the office in his ninja outfit, bothering the people who are really working. He has also been showing off his Tekken 2 and Street Fighter Alpha 2 prowess.

EDITOR'S CHOICE

Gold Awards are granted to games with a total average score of eight, while games that average nine or above receive Platinum Awards

PLAYSTATION CRASH BANDICOOT

SONY



GAME OF THE MONTH

CATEGORY: ACTION

BACK-UP: PASSWORD/MEM. CARD

BEST FEATURE: GRAPHICS

WORST FEATURE: NARROW PATHS

ALSO TRY: RAYMAN

So here it is. Sony's hot mascot. The marsupial from down under that uses his hooked toe to clean the lice from his fur...er, is that a special move? I like Crash. It's not the best action game I've played, but it's a lot of fun. It's like the original Mario with some 3-D effects thrown in. Note that it is not a 3-D environment per se, but it does have certain 3-D elements. What's nice is that the game isn't always from the same viewpoint. Sometimes you play in a Side View Mode, other times you're behind Crash then other times CB is running at you. Crash himself is a very cool character and so are many of the enemies.

Crash Bandicoot is an excellent all-around title. It has it all, lots of levels, great animation, variety and most importantly, fun. The game borrows a lot from many titles from the past, like Donkey Kong Country, Super Mario and Taz. Crash takes the best elements from all of these. The levels change all the time, so one minute, you're playing a side-scroller, the next, a forward scroller. The enemies were a bit too easy to kill for the most part, since you can just spin your way through them. My biggest gripe is Crash's handling. His jumps are too slow and inaccurate. You might find yourself missing a narrow platform once in a while.

Of all the PlayStation games released so far, Crash Bandicoot has the best graphics. Its colorful, hi-res visuals are astounding—especially in the river levels, which look...well, convincingly wet. Of course, pretty pictures don't make a perfect game. Yet Crash is almost as fun to play as it is nice to look at. While the gameplay won't win any awards for originality (you jump on and spin into enemies, after all), Crash does control well and is packed with lots to do (hog riding, anyone?) The fact that you can gather gems to unlock secret areas also knocks up the replay value. Still, the mostly linear levels don't allow too much exploring.

I felt Crash was the highlight of the many titles at E3. The characters and the bright graphics in the stages caught my attention, and the gameplay kept me interested. However, I thought I was in store for a disappointment by being forced to stay on a single path. Although most of the game is limiting in that manner, the action is still intense and challenging to keep players from wondering what could have been better. Running away from stone boulders, riding pigs and breaking things makes Crash a fun game to play that should not be missed. I suggest checking Crash Bandicoot out!

VISUALS	SOUND	INGENUITY	REPLAY VALUE
9	10	6	7

SATURN ROBO PIT

T'HO



CATEGORY: FIGHTING

BACK-UP: SYSTEM/CARTRIDGE

BEST FEATURE: WEAPON CHOICE

WORST FEATURE: SMALL ARENAS

ALSO TRY: VF KIDS

Interchangeable arms—a dream many of us will never be able to live. Since this is the case, Robo Pit will have to do and it does well. Robo Pit isn't a spectacular game. The graphics are great, but the game itself isn't anything special. For a good time I would have to recommend trying it. The Split Screen Mode is a lot of fun for two players. What's nice about the game is that it features 101 enemies. The only thing is that once you make it through all of those obstacles, I wonder if you'd want to play it through again. For me, I didn't. The arenas are simple looking, but there are quite a few different ones, so that variety is nice.

Robo Pit is a blender mix of Jumping Flash! and Cyberseed. The concept is excellent. You can customize a little robot and decide things like how it gets around (wheels? spider legs? etc.) and what kind of weapons it has. If you win your own-one battle, you can sometimes keep parts of your opponent and add them to your own robot. Sounds great, right? It's just too bad that the gameplay is mediocre at best. The action is slower-paced than Cyberseed. The battles are not that exciting to watch, much less play, and they can go on forever. Robo Pit is a nice try, but it could use a new design in the gameplay department.

Robo Pit isn't your run-of-the-mill fighting game. For starters, it pits your robot against a whopping 101 mechanized opponents. You can also build your 'bot from the ground up, giving it custom body parts to increase its leaping, running or fighting skills. But the game's best feature is the huge assortment of often wacky arms you can collect and attach to your robot (I prefer the suction-cup launcher). Unfortunately, combat isn't all that exciting. Besides a few fancy punches and whatever attacks you get from your arms, your robot's list of special moves isn't all that special. The texture-mapped combat arenas aren't very big, either.

Robo Pit is a cross between a typical arena game and a limited combat version of Jumping Flash! Play is fast and changes constantly with the addition of new weapons to your character after every stage. Each enemy that attempts to stop your progress up the elimination ladder is very capable of sending you to a fiery grave if you're not careful. I found the reward feature one of the best options. It allows the player to loot the carcass of a fallen opponent after the match and take his weapon-packed arm. These small options that allow a player to customize their robot to their liking are what make this title worth playing.

VISUALS	SOUND	INGENUITY	REPLAY VALUE
7	6	7	6

SATURN

GRID RUNNER

VIRGIN



CATEGORY: ACTION

BACK-UP: SYSTEM-PASSWORD

BEST FEATURE: 2-PLAYER MODE

WORST FEATURE: CONFUSING

ALSO TRY: REAL LIFE TAG

It's always good to have a few really fun two-player games in your collection. This way when your pals come over and want to play some games, they don't have to sit there and watch you play an RPG or something—it's just not as fun to watch. Grid Runner is a great addition to anyone's collection as a two-player game. As a one-player game, it's pretty good too. The graphics are a little jagged at times but the ground warping is a cool effect. What really makes me like this one is the Two-player Mode though. I just really enjoyed running around on the grid as your opponent was after you. I think it's more of a two-player game

Original and fun? Quite a feat for game companies today. But Virgin has managed that with their Grid Runner. It's a fast-paced action title that's extremely easy to pick up and a bit hard to put down. The object? Basically, it's tag means capture the flag. The (human) Two-player Mode is the best, though the way the game is set up, you'll have to steal all the flags from your opponent to win. Therefore, some long, drawn-out battles can occur when two people are equally skilled and stealing back and forth from each other. This prevents close games. Also, sometimes the action is too furious, which leads to some confusion

Who'd have thought a video-game version of tag could be so much fun? From the second you fire up Grid Runner, you're caught up in a fast-paced chase that—depending on the skill of your opponent—can last anywhere from one to 10 minutes. And your ability to teleport, drop mines and hurl spells at your opponent adds a tad of strategy to the pursuit. The one-player game is decent enough, but it's Grid Runner's two-player, Split-screen Mode that gamers will probably play most. The only problem is your runners get a bit tiny—and hard to see—in the two-player Mode. The graphics move kinda 'jerky, too.

If you are into two-player arena battling, Grid Runner is your game. Players will find the graphics really crisp and the action smooth and fast-moving. Although there are many key elements to this title that are apparent as soon as the game is sparked up, players will find the most enjoyment hunting out their friend and blasting him back to the Dark Ages. The story's plot isn't anything great, but it does suffice to get the players in the ring and make them start searching out each other on the network of grids in the stages. Many close friendships could easily be destroyed by this title.

VISUALS	SOUND	INGENUITY	REPLAY VALUE
7	7	9	9

SATURN

TETRIS PLUS

JALECO



CATEGORY: PUZZLE

BACK-UP: SYSTEM

BEST FEATURE: 2-PLAYER MODE

WORST FEATURE: OLD FORMULA

ALSO TRY: BAKU BAKU

I've always been a sucker for Tetris—actually any puzzle game! Tetris Plus is a good one to get because it just doesn't give you another Tetris. The game really is Tetris with a plus. The story for the Puzzle Mode is a little silly but I guess Tetris is a little silly to begin with. The control is strange since you have to tap the D-pad and then hold it down to move the blocks around. It's kind of like they have acceleration or something. Hopefully, you'll understand when you play it. Besides this, you can make your own puzzles in the Edit Mode! Overall, the game is a lot of fun with decent graphics and some cool modes of play.

Like Michael Jackson, Tetris knows how to make a comeback, but a lot of us are tired of it by now. Tetris is a classic, absolutely no doubt. It defined one of my favorite genres—the puzzle game. I still remember having dreams about falling blocks from too many hours of the game. This version is the best way to get this game. It has a two-player Competitive Mode which is not like the original's; this time, you can add blocks to your opponent's side. You can build and customize your own levels too! This would almost be perfect, if I hadn't played the hell out of the original. Still, it's a good package for even a part-time Tetris fan.

I used to be a big-time Tetris fanatic (I have a hot-pink Tetris game watch to prove it), so I was all geared up to play Tetris Plus. And the game doesn't disappoint. It lets you play just plain old, classic Tetris (which is 80 percent of the reason to buy this game) as well as a goofy variant with individual puzzles. Two players can play independent Tetris games at any time or battle each other in the Versus Mode. You can even edit the playfield to create especially tricky Tetris scenarios. Sure, the graphics are nothing special, and this game could easily have been done on the Genesis, but then Tetris' success was never built on fancy graphics.

The most amazing thing about all the Tetris titles that have been released are the minds behind them. Each one has new and different features to keep players interested in what is nothing more than the same old block game with lots of extras. Tetris Plus is again one of those titles. But now, there is a professor/scientist to save as well as the ability to build your own puzzles. Tetris Plus is a rewarding title with multiple levels of fun with the same classic challenge. If you can't stand to be without the latest Tetris release to pile up on your shelf next to the dozens of others, pick this one out.

VISUALS	SOUND	INGENUITY	REPLAY VALUE
4	5	7	10

SATURN

THREE DIRTY DWARVES

SEGA



CATEGORY: ACTION

BACK-UP: SYSTEM MEMORY

BEST FEATURE: ENEMIES

WORST FEATURE: COLOR PALETTE

ALSO TRY: GUARDIAN HEROES

Three Dirty Dwarves features some of the most hilarious animated cutscenes since Chuck Rock II for the Sega CD. There has been a little buzz about the game, especially since the company behind it is SegaSoft—people's curiosity has been aroused. The game's controls are great. I had a lot of fun seeing what each dwarf was capable of. Some of their special moves are excellent-looking. The enemies and Bosses in the game are funny as all heck—they look like they're straight out of *Liquid TV* (if it was still around). At first, it seemed hard, but as you played it, it kind of became too easy. This could be a problem for long-term play

Three Dirty Dwarves is an excellent side-scrolling Final Fight with a dose of humor. The cartoon enemies were hilarious, for once, I didn't want to hit the button to skip them. The game was hard and easy at the same time. Wait, you ask. How can that be? Well, it was easy to get hit in the game. That's the hard part. The great thing is, your teammate can come and revive you, or you can do it yourself by wiggling the D-pad. The only real way to die is to have all three teammates die at once. This made it very enjoyable to play, taking any possible frustration out of the game. TDD is simple and fun, but definitely mindless.

TDD just goes to show that next-gen games don't have to be 3-D to be fun. This game tosses a few new features into the stale side-scrolling genre, like being able to choose between characters in the middle of play (kinda' like in Donkey Kong Country, except the dwarves can all join together for special moves). Two or three players will have a blast in the Multiplayer Mode. TDD is loaded with personality and features cartoony but likable graphics. The cartoon enemies are especially weird and entertaining. On the downside, TDD is extremely difficult and often frustrating. Making it through the game's 15 levels ain't easy.

Any well-done Final Fight-style game is usually good enough for two players to waste some time with and have an enjoyable experience. Three Dirty Dwarves goes one further by allowing players to enjoy themselves with the grossly misproportioned characters in many challenging levels. I feel the graphics are perfect for what the game tries to be, along with the unusual form of attacks the heroes use. The enemies are also worth mention. There is actual strategy to defeating the Bosses and hilarious interaction with the pedestrians in the background—the perfect balance for what TDD tries to be.

VISUALS	SOUND	INGENUITY	REPLAY VALUE
7	7	7	6

PLAYSTATION

BEYOND THE BEYOND

SONY

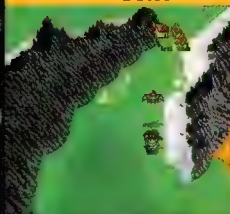

CATEGORY: RPG

BACK-UP: MEMORY CARD

BEST FEATURE: FINALLY, A REAL RPG

WORST FEATURE: LONG CUT SCENES

ALSO TRY: KING'S FIELD

Being the first true RPG on the PlayStation, I was impressed with *Beyond the Beyond*. The graphics were bright and colorful during the game and the battle sequences were even better-looking texture-mapped scenes. I got a little annoyed with the scaling whenever a battle started. The first few times it was okay, but after the seventh or eighth battle, it was unnecessary. I did like it when the main characters jumped for joy after they won the battle. The story line was pretty standard but that's not a major problem. Besides this, the music sounded great. Overall, I think *Beyond* is a safe purchase for any RPG fan.

I wonder why 99 percent of RPGs must look the same? You know what I'm talking about: the same overhead view, the same short characters, etc. *BTB* is no better. In fact, the characters are smaller than they are in most games. The battle scenes, however, do look good. Besides that, some of the conversations are really tedious. It seemed that there was more talk than action. I almost fell asleep waiting for all the people to finish chit-chatting. After a while, I was hitting "X" just to wrap things up. It should have been balanced better. In other news, the story is standard RPG fare (pretty good), and the music is excellent.

PlayStation owners have been screaming for an RPG since their system came out, and now they finally get one. The only trouble is, *BIB* doesn't pump out enough visual spark to come off as a true 32-bit, next-gen RPG. Besides its 3-D battle scenes, cool magic attacks and colorful graphics, *BIB* isn't much of a step up from the 16-bit RPGs. Still, it offers a solid quest (although the cut scenes run too long) and lots of locales to explore. Since PlayStation gamers have been without an RPG for so long, *BIB* will do for now. But with ultra-stunning titles like *Breath of Fire 3* and *FF7* on the horizon, it's hard to get too excited.

Based on Sony's biased opinion about RPGs, I was expecting a lot more from the title being billed as the platform's first true role-playing game. This in turn hurts my rating for the game because I was expecting more even though everything is still ideal for the occasional RPG fan. The graphics and the story however are really complete and bear testimony to the PlayStation's ability to top-quality titles currently out there like *Working Design's Shining Wisdom*. Next time Sony, don't ignore the RPG audience. Policy like this converted many pro-PS gamers to get a Saturn in order to play the games they enjoy.

VISUALS	SOUND	INGENUITY	REPLAY VALUE
6	7	5	3

PLAYSTATION

PROJECT OVERKILL

KONAMI



CATEGORY: ACTION

BACK-UP: MEMORY CARD

BEST FEATURE: REALISTIC GORE

WORST FEATURE: CONTROL

ALSO TRY: STEEL HARBINGER

Man, did I like *Project Overkill*. I hate to admit it, but it's fun to shoot people when you know they're the bad guy. Understand that I wouldn't kill anyone in real life—unless, of course, they took away my PlayStation or Saturn, but I digress. The graphics are sharp and the character animation is awesome. When killed, some enemies spurt blood while others just slump over—it looks very cool. It's not just a blood fest though, and that's the beauty of *Project Overkill*. With all of the killing and destruction, there really is a great game underneath with difficult missions to complete. The control is what brings this one down.

I don't know what it says about our society when games like *Project Overkill* have a market among gamers. It's very violent and mindless. BUT, among the violent and mindless shoot-'em-ups, *Overkill* is one of the better ones. The levels are always scattered with health and ammo power-ups, so the game is not terribly difficult. The controls take some getting used to, and while you are mastering that, you'll expend plenty of ammunition trying to aim at enemies, which is a wee-bit hard to do. Some enemies can shoot you while they are off the screen or behind walls. This is the game's worst feature as you can't avoid the hits.

There's no shortage of enemies to eviscerate in *PO*. I just wish it was a whole lot easier to kill them. The control in this game is awkward, since you have to aim your guns with the four joystick buttons (like in the Super NES version of *Smash TV*). Consequently, you waste way too much ammunition trying to nail one bad guy simply because he's standing diagonal to your character. You can choose a second control method, but it's even worse. Your character does get a bit easier to control after some practice, and the isometric levels are large and detailed. The game also offers plenty of levels and buckets of blood and guts.

Project Overkill is a great Rambo-style title that allows the player to take his/her chance at breaking through near-impenetrable defenses to complete a mission. I instantly identified with the differences of the four characters and enjoyed the different style of play each required to use effectively. The graphics are really sharp and give the player shocking realism strewn with gore as they gun punch and stab their way through the human enemies. The sound also adds to the realism by audibly conveying the sound of a knife punching through an opponent's back as well as others. A must for lovers of challenging, violent games.

VISUALS	SOUND	INGENUITY	REPLAY VALUE
8	8	6	6

PLAYSTATION

SPOT GOES TO HOLLYWOOD

VIRGIN



CATEGORY: ACTION

BACK-UP: PASSWORD

BEST FEATURE: CINEMAS

WORST FEATURE: CONTROL

ALSO TRY: CASPER

Let's just start by saying that *Spot* is a pretty cool little character. He doesn't talk much—at least in English—but he makes up for that with style. *Spot* is a fun game that's graphically impressive but has some problems with control. The screen movement is jerky and the three-quarter perspective is confusing when you're trying to locate a power-up in the air. You can make the control non-isometric which makes things a little easier but overall, the control is far from perfect. There is a large variety of levels to see and the cinemas in between are pretty damn cool. I dig the parodies in the game and the enemies are great-looking.

Spot is too darn cute. The cinemas in this game were great. I laughed; I cried. The game itself was at best, pretty good. I didn't feel like I was playing anything that I haven't played before. Besides the perspective, this *Spot* title practically played identical to the old 16-bit titles. Speaking of the perspective, the three-fourths view doesn't cut it for *Spot*. Sometimes, my shooting or jumping aim was slightly off. It reminded me of the trouble I had as a kid playing *Zaxxon*, because I couldn't really tell where I was heading. The controls also need tweaking. *Spot* was just too sensitive to handle. Not a bad game; just not perfect.

The Super NES and Genesis versions of *Spot* scored high with *EGM* because they both had sharp graphics and great gameplay. This 32-bit update only does half the job. While the game's plenty pretty to look at, it gets repetitive and plays only so-so—mainly because the control doesn't work well with the isometric view. You can choose between three control modes, but each one made my hands sore after a few minutes of play. The isometric perspective also makes it hard to judge the position of certain obstacles. These gripes aside, *SGH* is a decent enough game. Players will get a kick out of its weird levels (one's even inspired by *Zaxxon*).

Spot has found a new home on the PlayStation. His latest port gives players all the fun and imaginative levels as his 16-bit predecessors and mixes them with the play speed of a next-gen system. Controlling *Spot* is a difficulty that has to be overcome by the player. This is caused by the 3-D isometric viewpoint which makes it hard to orientate your character in the stages, but nonetheless can be overcome with practice. The best feature in the title is the ability to comb through the movie-based levels and be apart of them. Everyone should experience a day in the life of the soft drink mascot.

VISUALS	SOUND	INGENUITY	REPLAY VALUE
8	8	5	6

Shawn

Dah

Crispin

Sushix

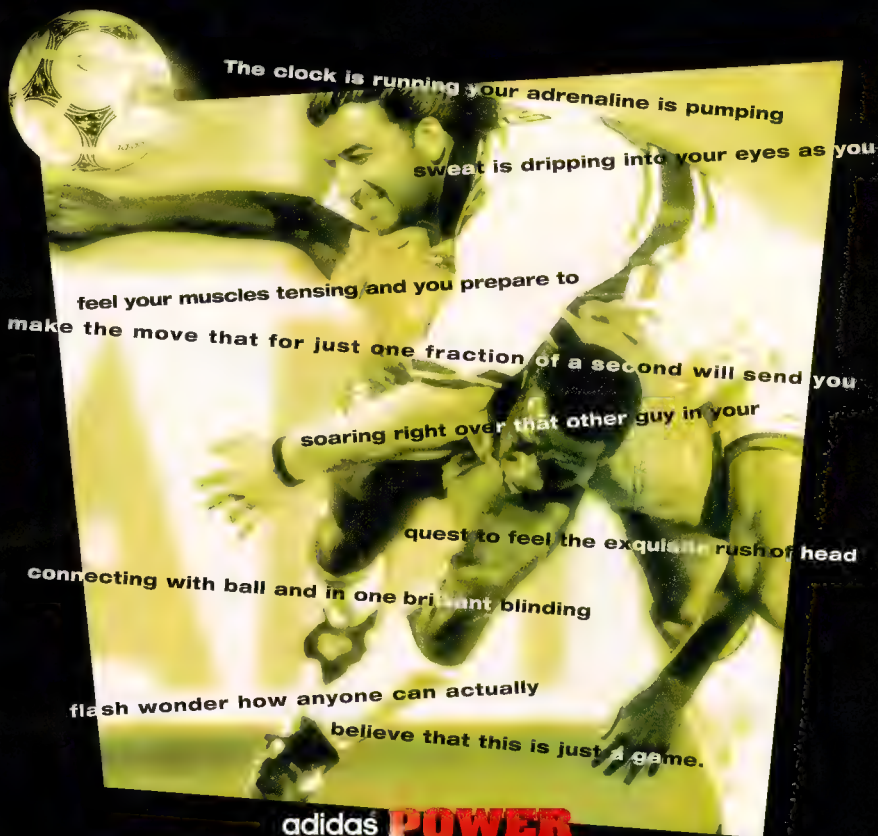

The clock is running your adrenaline is pumping
sweat is dripping into your eyes as you

feel your muscles tensing and you prepare to
make the move that for just one fraction of a second will send you

soaring right over that other guy in your

quest to feel the exquisite rush of head

connecting with ball and in one brilliant blinding

flash wonder how anyone can actually

believe that this is just a game.

adidas **POWER SOCCER**

THE LAST WORD IN FAST, FURIOUS FUN FROM THE FIRST NAME IN SOCCER!



Fast and Furious Arcade Mode



Tons of Special Moves



Motion-Captured 3D Graphics



www.psychosis.com



PlayStation and the PlayStation logo are trademarks of Sony Computer Entertainment Inc.
Power Soccer is a trademark of Psychosis. Made under license from adidas AMERICA, Inc. © 1996 Psychosis Ltd.



Race with 35 of the fastest, most maniacally-aggressive drivers on the paved planet. (The only thing you'll lack is a fireproof body suit.)



26 cars perfectly mirror their real-world counterparts. If you plow into a sidewall, you better count on a pit stop and collision repair.

**SEE MONTE CARLO.
AT A LEISURELY 200 MPH.**



Guitar gurus Steve Vai and Joe Satriani provide the high-octane road tunes. (Playable in mono, stereo, Dolby Surround or Q-Sound.)



Trees, buildings, grandstands and surrounding scenery added from over 100 hours of video footage. (Sorry, winner's circle limbo's not included.)

Legal stuff: PlayStation and the PlayStation logo are trademarks of Sony Computer Entertainment Inc. Licensed by FOCA to Fuji Television. © 1998 Polygram, Ltd. The Legal Roadster at Polygram in no way supports reckless driving, excessive speeding or smoking of tires in public places. Also, to help cover their holes, they would very much like to go on record with the following advisory: please do not attempt reading mouse logs (such as this) at velocities in excess of, say, 200 miles per hour. Heet, heet. AGES 17



Polygram, Ltd. is a registered trademark of Polygram, Ltd.



Hit 17 of the world's most famous race tracks — each recreated from official FIA surveyor's maps, each replicating actual specs.



Choose your race style: Arcade mode, two player mode (for you competitive types) or Grand Prix sim mode for hard-core purists.



Hyper realism to the extreme: 256 colors, 150,000 polygons at 30 fps. Ambient in-car sounds taken from actual F1 cockpits.



www.psygnosis.com

START YOUR PLAYSTATION.
FORMULA 1, THE GAME.

SUPER NES

MS. PAC-MAN

WILLIAMS



CATEGORY: ARCADE CLASSIC

BACK-UP: PASSWORD

BEST FEATURE: 2-PLAYER COOP MODE

WORST FEATURE: OLD GRAPHICS

ALSO TRY: ANY PAC-MAN GAME

What is there to really say about Ms. Pac-Man? The original arcade was a whole lot of fun. Sure, it wasn't a Mario 64 with the flashy graphics, but it was a blast to play. This new version of Ms. Pac-Man for the Super NES is the same way. It doesn't have scaling and rotation effects. It doesn't have cool sounds or cool graphics. For some, I can see how this is old-fashioned but for me, it's refreshing. I liked all of the various modes you can change like the size of the board and the type. The turbo addition is a nice touch, too. I was a little surprised to see slowdown at times when the board scrolled up or down.

Having never played the Genesis version, my only impression of Ms. Pac-Man was the old arcade version. I was expecting the old game, which was okay, but tired. I was very surprised to see all the new options available, like the different levels (such as the "crazy" designs) and a Turbo Mode. The best, however, is the two-player game. You can play cooperatively and competitively. It is truly a lot of fun. This is also the type of game you can show to non-video game players to get them hooked. Ms. Pac-Man is wholesome fun for any demographic group. You'd have to be crazy not to like this title; I highly recommend it.

It's hard to pass a Ms. Pac-Man arcade machine without dropping a few quarters in it. The game's still addictive—and this Super NES version is a near-perfect port. Better yet, it one-ups the arcade original by letting two players zip around the mazes simultaneously in either a cooperative or competitive game (although the whole maze doesn't fit on the screen and sometimes players lose sight of their Pac person). Still, an excellent conversion of an arcade classic may not be enough to please all gamers—especially those too young to have nostalgic over the original. I wish this cart had a few more games (Super Pac-Man, anyone?)

Ms. Pac-Man was one of the sorriest sequels ever created even in the early days of video gaming. When I look at this title even now, I see a character that made a LOT of money now cross-dressing by wearing a bow trying to make even more. The game, however, is a good translation with the various game options such as a larger screen, Boost Mode and Dual Player Simultaneous Mode. In today's video game market, Ms. Pac-Man may not appeal to the younger audience who have only seen pictures of the Pac family. A fun classic but suffers horribly in the '90s with an audience who grew up on Street Fighter and Mega Man.

VISUALS	SOUND	INGENUITY	REPLAY VALUE
5	6	6	9

GAME BOY

**BATTLEZONE/
SUPER BREAKOUT**

T'HQ



CATEGORY: ARCADE CLASSIC

BACK-UP: NONE

BEST FEATURE: SUPER BREAKOUT

WORST FEATURE: BATTLEZONE

ALSO TRY: KIRBY'S BLOCKBALL

What a pleasant surprise. Not so much for Super Breakout but for Battlezone. I didn't realize the Game Boy could do vector graphics but I guess it can...kind of. Playing this one on your Super Game Boy is the way to enjoy the game(s). The SGB gives color to Super Breakout and BZ. Playing either of these titles on the regular Game Boy is fun but graphically unimpressive. As I played Battle Zone I actually felt like it was on the arcade...er, maybe not quite on the arcade but pretty close. I'm not sure if I like the idea of companies making games more for the Super Game Boy than the regular old Game Boy. Oh well.

It's too bad I have to write a paragraph's worth of text, because I can sum up this review in one word: no. That's no for "no fun" and "no value." The Battlezone game almost looked like it had potential. On the Super Game Boy, the graphics looked clean and crisp, just like the arcade original. Once you start playing, however, you see how poor it is. Battlezone is a simple game that should have been easily translated on the Game Boy, but it wasn't. It was choppy and slow. Breakout and its variants were decent, but it's an old game. Breakout fans should get Arkanoid, or even better, Kirby's BlockBall instead.

Don't bother buying this game to play Battlezone. The tank game may have been a blast to play in the arcade 15 years ago (when it had two joysticks), but the Game Boy version is worthless. The graphics are jerky and the game's too repetitive. Super Breakout is a different story. The game was an instant classic when it was released for the Atari 2600, and it's still fun to play. The Game Boy version has more than enough screen layouts to keep you breaking blocks for hours. But is it worth buying? Not when you can plunk down your dough for Kirby's Blockball, a much more modern and exciting update to Breakout.

Battlezone/Super Breakout for the Game Boy is a decent title. All the highlights of the original action have been kept intact even through the conversion. As I've stated before, the revival of classic games is a touchy subject for many gamers, but a game like Breakout is a perfect title for the portable power of the Game Boy. A new generation of gamers now have the chance to experience the first attempt at a 3-D med title and the classic Pong-style game. A problem I see affecting the enjoyment of this title, as well as most GB titles, is the small screen. Distant enemies and the small ball are consumed by the background.

VISUALS	SOUND	INGENUITY	REPLAY VALUE
4	4	3	5

GAME GEAR

X-MEN 3

SEGA OF AMERICA



CATEGORY: SIDE-SCROLLER

BACK-UP: NONE

BEST FEATURE: LOTS OF X-MEN

WORST FEATURE: EVERYTHING ELSE

ALSO TRY: IRON MAN/X-O

The hardest part of being a reviewer in a land full of 32-bit (and now 64-bit) systems is the old, and many times very good, 8-bit system games. X-Men for the Game Gear is a good-looking game but really lacks what it takes to be fun. The game that always seems to remind me of this is Chuck Rock II for the GG. X-Men is not fun like that one is. The graphics in X-Men are actually very good, but the enemies can take far too many hits before they're dead and the levels are too barren. I like that you can choose what member of the X-Men you can control as you advance, but that doesn't really make up for the poor gameplay.

This game looks and plays identical to Iron Man/X-O or RoboCop vs. Terminator, with only a slight change in backgrounds and main characters. What makes this title stand out is the use of the various X-Men, each with his or her own power. Truthfully, even that didn't thrill me. This game is also much harder than the aforementioned titles. I guess the two difficulty settings—Maniac or Suidical—was a good indication of that. The enemies all look several hits to kill, and unless you are a master ninja video game player, you'll take hits while trying to kill them. Jumping from platform to platform was inaccurate and frustrating.

I'm really fed up with dull, no-frills side-scrolling games like X-Men 3. This title demands no strategy—and even less thought; you just traipse around level after level and beat up badly animated bad guys while listening to annoying music. Sure, the levels are plenty big, but your character moves so slow he or she takes forever to get anywhere. At least you get to control several different X-Men (new ones become available as you complete each level). Each X-Man can also use a special attack, which takes some of the monotony out of killing enemies. The sad thing is we've probably see more games like this for the Game Gear.

The characters in X-Men 3 have a handful of good moves as well as interesting special moves that are unique to each character. The levels are sized largely and offer the player many areas to search for the fun items such as power-ups and activator switches. When I first sparked this one up, I feared that the only two characters I would be able to play were Wolverine and Rogue. I was later thrilled to find that Gambit and others could join the force and make a sizeable team. X-Men 3 is not a great game, but it's interesting enough to be worth the cost for players who refuse to let the Game Gear die.

VISUALS	SOUND	INGENUITY	REPLAY VALUE
4	3	3	3

Shawn

Dan

Crispin

Sushi X

Behind The SCREAMS

It all started with a wish list. Design and Layout coordinator David "Commander" Silveira and Production overseer, Mark "The Monk" Johnson (doubling as ASCII's video game consultants and game masters) were given the opportunity to make a wish list for everything they wished had been in *King's Field I* and everything that could have been better that was already in the game. Combining feedback information from the consumers via the On-line News Groups, registration card information, and their own ideas, they put together a list of upgrades that would make the ultimate game. After presenting the list to From Software, Inc. of Japan, ASCII also added Austin (as in "Prince") Leminger to the ranks of the *King's Field II* team to help implement the upgrades and make *King's Field II* a smashing success!

"Rewriting the Japanese script was a blast," quoth Austin. "It was the opportunity to actually create an entire script for a video game only limited by the original story line from Japan."

The improvements over *King's Field I* include...

- Larger world to explore.
- Outside areas of exploration.
- CD Quality music and sounds.
- Improved character definition and dialog.
- Enhanced storyline and plot.
- More fearsome enemies.
- Enhanced weapons and magic.

And Much, Much MORE!



THE FACE OF THE ENEMY!

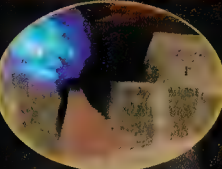

Behind The Screams...

While the first *King's Field* was a phenomenal success, ASCII's wish list satisfied with just putting out a sequel with the same great features that made *King's Field*. So they put their best American team on the project working directly with From Software, Inc. of Japan to make *King's Field II: The Grimoire Book*. How not game of the year!

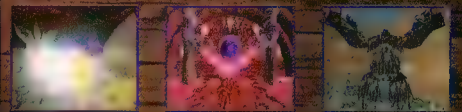

mind at ease. ASCII did leave in some of the already refined elements that made the first *King's Field* a roaring success. The intuitive control and pop-up menus remain unchanged for the most part. ASCII did, however, add a feature to the "System" menu which allows you to change the default button configuration to anything you want. This feature gives you just that much more control over how your game acts and reacts.

This much anticipated sequel to *King's Field* would have done incredibly well even without the

vast improvements. Just on the promise of the same quality in the beautiful 3D polygon graphics and intensity of gameplay, *King's Field II* would have been a sell out game! But with improved sound, graphics, and storyline; along with a humongous world to explore, *King's Field II* is destined to be one of the top sellers this holiday season and well into next year!

I would wish good luck to you, Prince Austin Lyle Forester...but you're gonna need a lot more than luck to make it through this one!

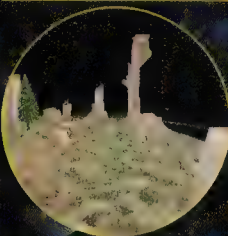

Inside Edge

King's Field II is immense. Your only hope of exploring the whole thing is to acquire the *Play Map* early on in your quest. (It's an automap which maps everywhere you go in the game.) Each village, castle, dungeon, and underground has its own map, so figuring out where you've been is as easy as pulling up your status menu!

To find the *Play Map*, you must make your way through *Barde's Tower* (a maze just beyond the gate in the first town) when you've made it through the maze, you'll receive this map along with another important item.

Receive the *Play Map*, you will have access to *Barde*, the character that holds it. It is important to speak with every character you come across every day, not just the ones that are new. Characters change what they say after you've visited other villages and allies, so talk to them often! For reference, your character keeps a log of all conversations automatically.



PLAYSTATION



KING'S FIELD II

The King Is Back, But His Field Has Changed!

No more Mr. Nice King! He's working for the dark side now! King Alfred, the Holy King of Verditte has fallen victim to the minions of evil as ASCII Entertainment brings in another installment of last winter's hit PlayStation title *King's Field*!

In *King's Field II*, you will find the same gripping elements you found in the first *King's Field*, only with even **MORE** of the fantastic elements that addicted you to the original.

An awesome new world lies before you as you embark on your new quest. ASCII obviously put in an incredible amount of work to make this new quest in the kingdom of Verditte as lavish and realistic as possible. This realism stems from the same technology that was used in *King's Field I*, but this time, you have the entirety of the kingdom to explore!

Outdoors, inside castles, villages, underground passages and dungeons — all combine to make an immense world that will have you immersed within moments. Make no mistake, this is no ordinary sequel. Numerous upgrades and captivating elements mix with the most addictive points of the original top-selling adventure to bring you the hottest new title to hit the PlayStation this year.

As you may recall from the first *King's Field*, a 3D texture-mapped, 360° world of larger-than-life enemies lay before you on the monster-infested island of Melanat. Shipwrecked on this island, you were to battle your way through levels upon levels of dungeons and monsters in search of the Moonlight Sword which was stolen from the King's Throne in Verditte (the kingdom on the mainland).

Your character, Alexander, learned magic spells, grew more skilled with his sword, and was able to pick up and equip any weapons, armor, or items found on the island. All of the elements of a winning RPG were packed into a first-person, Action/Adventure outer shell — bringing a very unique game to the genre which held the attention of most everyone. With vast improvements over the first, *King's Field II* is bound to share the same success story!

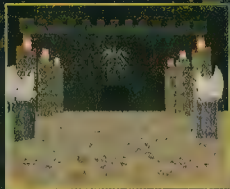

One of the most riveting elements of the new quest is that the storyline has been greatly improved upon! I know that a lot of us thought that the first *King's Field* was plenty deep, but ASCII has gone above and beyond to make this sequel an experience that will draw you deep into the involved plot — disabling you from putting down your controller until every last *Red Eye*, *Dragonewt*, and *Stool* are driven from the kingdom.

You start out the game with an introduction which allows you the chance to find out what has been happening since *Alexander* brought back the Moonlight Sword to the kingdom of Verditte five years ago. A cool intro

sequence complete with voice over and full-motion cinematics bring you into the world as the King's son, *Prince Austin Lyle Forester*, a title that should have everyone in the kingdom bowing to kiss your feet. Unfortunately, your father — *King John Alfred Forester I* — has fallen to the will of the evil forces which are attacking your kingdom.

Published by ASCII Entertainment, *King's Field II* is available for PlayStation. The game is rated "M" for Mature and is priced at \$49.99. It is available at most game stores and online retailers.

ASCII Entertainment
 PlayStation
 King's Field II
 Action/Adventure RPG
 \$49.99
 M
 1
 CD-ROM
 95%

sequence complete with voice over and full-motion cinematics bring you into the world as the King's son, *Prince Austin Lyle Forester*, a title that should have everyone in the kingdom bowing to kiss your feet. Unfortunately, your father — *King John Alfred Forester I* — has fallen to the will of the evil forces which are attacking your kingdom.

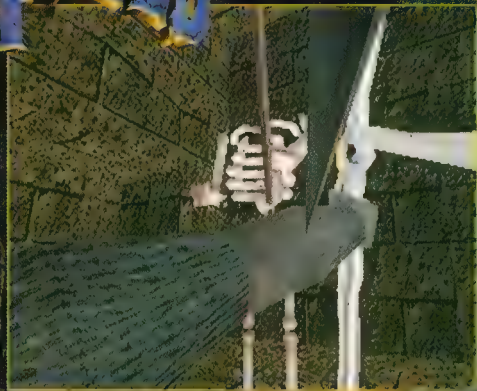

sequence complete with voice over and full-motion cinematics bring you into the world as the King's son, *Prince Austin Lyle Forester*, a title that should have everyone in the kingdom bowing to kiss your feet. Unfortunately, your father — *King John Alfred Forester I* — has fallen to the will of the evil forces which are attacking your kingdom.

Published by ASCII Entertainment, *King's Field II* is available for PlayStation. The game is rated "M" for Mature and is priced at \$49.99. It is available at most game stores and online retailers.

Published by ASCII Entertainment, *King's Field II* is available for PlayStation. The game is rated "M" for Mature and is priced at \$49.99. It is available at most game stores and online retailers.

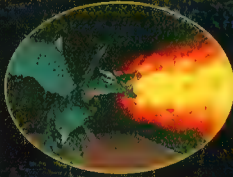

Published by ASCII Entertainment, *King's Field II* is available for PlayStation. The game is rated "M" for Mature and is priced at \$49.99. It is available at most game stores and online retailers.

PUBLISHED BY		RELEASE DATE	
ASCII Entertainment		Halloween '96	
SYSTEM		THEME	
PlayStation		Action/Adventure RPG	
# OF PLAYERS	SIZE	% COMPLETE	
1	CD-ROM	95%	



As you progress through the game to go out and save the world, you will have to talk to all walks of life in the kingdom. Eccentric monks, hate mothers, indifferent soldiers, even an occasional enraged monster will have a few words for you. Your challenge, of course, is to win the favor of the people so that they will give you the help you need as you try to

"It's so addictive, they'll have to cut the power to my house to get me to stop playing!"

— **Game Tester**

save the world. It's magic, may even rip it off, but, and collect treasure of power that can save your kingdom back together. Don't get me wrong, this is no "see king at home with your own chest needles" game we're talking about! You'll come up against some of the most frightening and powerful enemies since Clash of the Titans!

In addition to the game's storyline, ASCII has also put forth a valiant effort to come up with humorous and stimulating dialog and characters to bring your quest to life. Such characters as *Lock*, a 100+ year old resident of Verdun with a more than idiosyncratic attitude and a sunny disposition



him, will bring sparks of humor that you'll enjoy throughout the game! Even a bit of romance enters the quest as the scanty-clad elf merchant, *Lyn* — who has held a flame for the prince since childhood — drops hints about her feelings that even a *Golem* could comprehend.

Not to forget about the CD quality sound, of course! *King's Field II* has a wide selection of accompanying music to entreat your ears as you progress along your journey. Original scores are long enough to not sound repetitive, and yet are not so intruding as to distract from the ambience which they so artfully bring to the game. Other sound effects include terr-

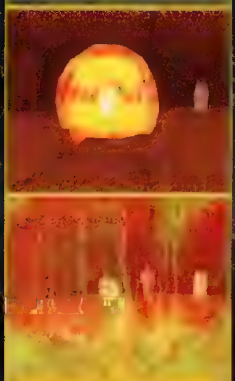
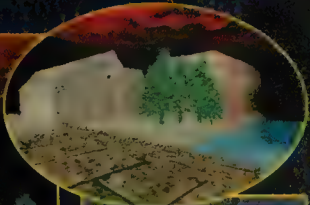

Swordplay...

The fighting technique in *King's Field II* is slightly different from the original. The enemies have been enhanced to recognize your pattern of attack so that they can turn, block, even parry and thrust to put you quickly into the realm of the dead! What you will have to learn is to circle and then double back to strike when the enemy is distracted. In *King's Field II*, you can live longer. As in the first *King's Field*, you can go in for a quick hit, but in *King's Field II*, you will be less likely to achieve success — the Skeletons, for example, now have the ability to block with a shield, duck under a slash, and stab you while you try to retreat!

In addition, use your magic as a distraction while you go in for a hit. Once you learn some spells, stun the enemy. When you go in for the kill, Enemies can use the same tactics, though, so be careful. They also attack in groups, so make sure that you don't get surrounded! Good luck!

fying wails, screams, and roars from the afflicted and from the enemy; thunderous explosions; the glorious sound of steel on steel during sword fights; and, of course, the exceptional Stereo effects that were such a notable achievement in the first *King's Field*! You can actually tell how close you are to a monster by how loud the eerie screeches and roars are — with some practice, you can even distinguish what you're going to come up against

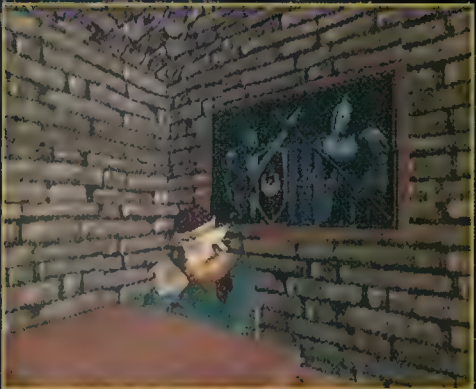

Remember me? Shore ya do...It's Leon Shore. Come visit my house whenever you need a friend or a guide.

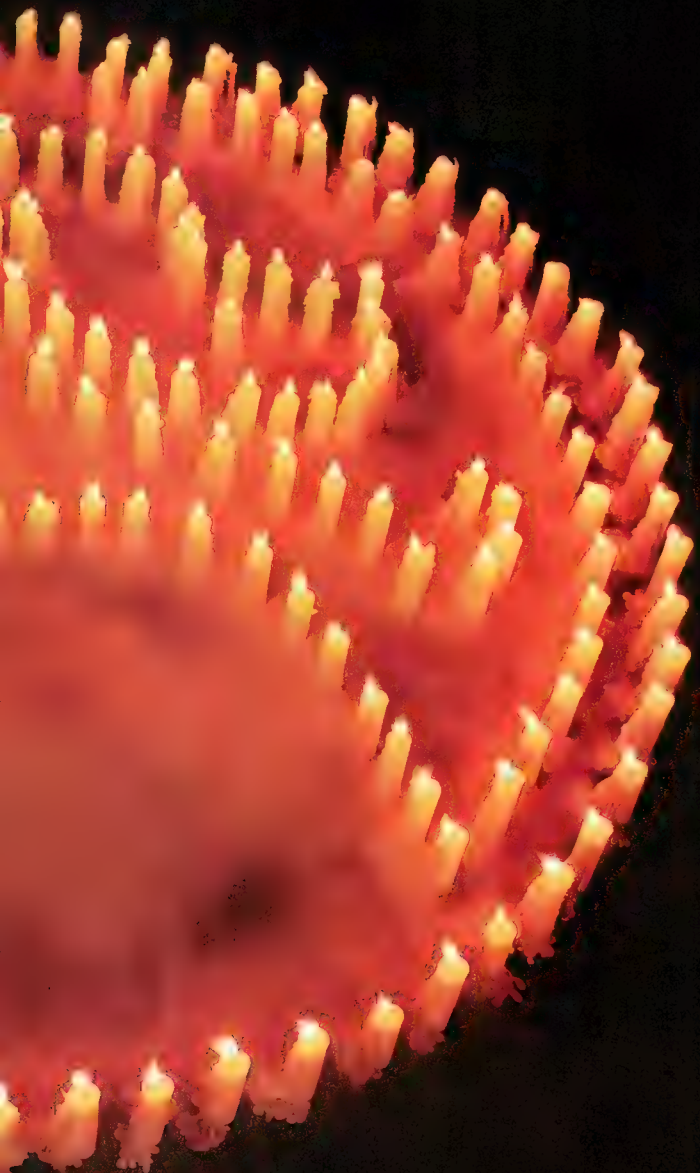

On energy and nine levels of energy, pain and suffering. And the living will envy the dead.

DRAGON FORCE™

3 Awesome Warlords!
3 Different Storylines!
150+ Playable Characters!
60+ Hours of Gameplay!

When Magic Was Young,
And Swords Carved Laws Of Blood,
Eight Warlords Forgotten To Time
Rose to Shape Order From Chaos.

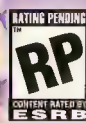

This official seal is your assurance that this product meets the highest quality standards of SEGA™. Buy games and accessories with this seal to be sure that they are compatible with the SEGA Saturn™ System.



SEGA SATURN™



Our games go to 11!™

SUPER MARIO 64

SYSTEM: **Nintendo 64** PUBLISHER: **Nintendo**

KILLER CODES

SUPER MARIO 64

—by Nintendo
for Nintendo 64

It really rots when you fall off something and the ground is about a mile under you. You could almost take half your life if you're not careful. However, there are quick and easy ways to prevent taking damage from a fall no matter how high your starting drop may be.

The main prerequisite is to not do anything fancy while falling. No dives, stomps or anything. Just free fall. Soon as you are about to land (watch your shadow to judge distance) either dive, kick or butt stomp. Do this by adjusting your speed and height so you will land with no damage taken at all!



There is also another tidbit to falling. On any stage that contains snow or sand, no matter how high you fall from, you will always make a safe landing. You will get stuck in many weird ways—but you will get out and live without taking any damage!



CHEAT SHEET:

1000 COIN TRIP



Go to any Bowser level and keep running around him and collecting coins he drops. Once 1,000 coins are hit, from now on, you will gain a life every time you die.

Here's an incredibly useful trick for those who can't stand constantly losing lives. First, enter any Bowser level (the first being the easiest). Get to Bowser, instead of killing him, just keep dodging his flame attacks. Every time he breathes fire, he will drop coins. Keep collecting coins until you reach 1,000. After this point, an "M" will appear by your number of lives. Now, exit the level, and let the fun begin. Every time that you die—no matter what horrible fate you put Mario through—you will gain a life instead of losing one. However, if you gain any 1-Up, you will lose one life. So be wary of instinctive greed for 1-Up collecting. Also, be wary that once you achieve 1,000 coins, you cannot save the game with this trick. So if you restart, you need to repeat the trick.



First thing is to enter any Bowser level.

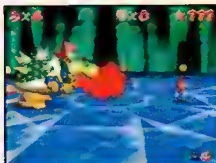

The first Bowser is the best to perform the trick on.

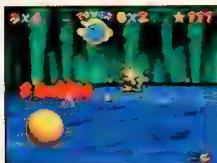

Let Bowser breathe fire. And then run to a nearby spot.

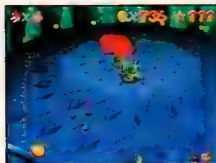

Once he tries to attack you again, run over and collect

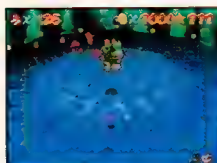

Repeat this pattern until you reach 1,000 coins.

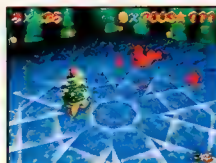

Once achieved, an "M" should appear by your lives.

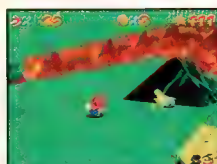

From now on, every time you die, you will receive a new life instead of losing one. Also, 1-Ups will remove lives.

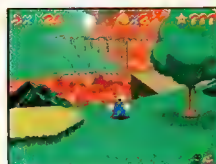

SUPER MARIO 64

SYSTEM: **Nintendo 64** PUBLISHER: **Nintendo**

CHEAT SHEET:

1000 COIN TRIP



While sliding down a slope, jump up, kick in the air and pull back while kicking. Repeat to go up a slope.

Ever encounter one of those fun slides that you can't get back up? Well, just jump up in the air when sliding, and kick in the air. While kicking, pull back. This will bring you back up the slide. Keep repeating this simple procedure and you could get right back up to the top in no time!



Keep doing Jump Kicks to work yourself back up slides.

SHINING SOLOMON™

**WIN
\$10,000**
CONTEST DETAILS
INSIDE PACKAGE

*When Evil Ascends,
And Darkness Consumes,
Wisdom Will Light The Way,
And Bravery Will Make It Shine.*

Contest Co-sponsors:

electronics



boutique

Where else are you gonna find

**ELECTRONIC
GAMING
MONTHLY**

10,000 Frames of SGI Animation!
40+ Hours of Intense Gameplay!
Cool Secret Zones and Items!



KIDS TO ADULTS



AGES 6+



SEGA SATURN



Our games go to 11!

SEGA AND SEGA SATURN ARE REGISTERED TRADEMARKS OF SEGA CORPORATION. © 1996 SEGA CORPORATION. ALL RIGHTS RESERVED. SHINING SOLOMON™ IS A TRADEMARK OF SEGA CORPORATION. SEGA SATURN™ IS A TRADEMARK OF SEGA CORPORATION. SEGA SATURN™ IS A TRADEMARK OF SEGA CORPORATION. SEGA SATURN™ IS A TRADEMARK OF SEGA CORPORATION.



SUPER MARIO 64

SYSTEM: Nintendo 64 PUBLISHER: Nintendo

KILLER CODES

SUPER MARIO 64

—by Nintendo for Nintendo 64

The turtle shell is a nice way to get around. However, there are many facts about the shell that not too many know about. While in the Lava Stage, you can get several 1-Ups by traveling on the lava. Remember, though, it is only obtainable on stars 1-5. It can travel on the quicksand on the Desert Stage, or water surfaces.

By rapidly jumping on steep surfaces, any surface can be climbed using the turtle shell, making it totally possible to go anywhere on any stage.

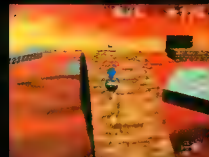

SUPER MARIO 64

—by Nintendo for Nintendo 64

Another trick to climbing steep surfaces is an odd but effective way. Just have Mario's bum get burned then he will run up anything!



CHEAT SHEET:

FIND YOSHI

POWER TRIP
HOT
NOT

Once you have obtained 120 stars, you will be able to use a cannon outside to shoot yourself onto the castle roof, where Yoshi waits to give you a big gift.



Get all stars and head for the cannon outside the castle.

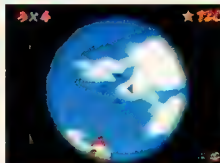

Fire yourself onto the roof of the castle.

The final event you can get in Mario is obtaining Yoshi. The first requirement you have to achieve is to collect all 120 stars in the game. Once this has been achieved, proceed to the outside of the castle. The grate near the pond will now be open and a cannon will be in there. Fire yourself onto the roof of the castle and there, wandering aimlessly, will be Yoshi. Talk to him to receive 100 lives and a new Triple Jump.



In the back will be Yoshi. Talk to him to receive 100 lives and a new Triple Jump. After this, Yoshi will hop away.

SUPER MARIO 64

SYSTEM: Nintendo 64 PUBLISHER: Nintendo

CHEAT SHEET:

WATER TRICK

POWER TRIP
HOT
NOT

Any time you are really damaged, jump into the water to refill your life meter.

In Mario, there are plenty of areas where you could easily get wiped out. Fortunately, if your stage should happen to contain any part with water, getting life energy back is simple. Any time you have taken any amount of damage, go to any source of water. There, simply jump into the deep end and float on the surface. Your life will then completely recharge.

For reference, there's water on stages 3, 7, 5, 6, 9, 11, 12 & 13. Stage 10 does contain water but it will kill you instead of heal you due to the cold.



In desperate need for some health? Find a watering hole.

Jump into the water and sit at the surface for a complete life restore!

**FIGHT YOUR WAY THROUGH TIME.
OR YOU'RE HISTORY.**



**Battle time's deadliest warriors. Master over 40 weapons.
Conquer 4 different worlds. Or the future is history.**



TIME COMMANDO™



Check out the demo and enter the Time Commando Sweepstakes at <http://www.activision.com> or
<http://www.mcafee.com/inforthome/>. Now available on IBM-DOS®/Windows® 95 CD-ROM and Sony PlayStation™

ACTIVISION

Activision is a registered trademark of Activision, Inc. Activision Software International and Time Commando are trademarks of Activision Software International. © 1995 Activision Software International. All rights reserved. Published and distributed by Activision, Inc. All other trademarks and trade names are the property of their respective holders.

KILLER CODES

SUPER MARIO 64

—by Nintendo
for Nintendo 64

While in the Desert Stage, you can get a star from the big vulture swooping overhead. After that, he will swoop down at you and steal your hat.

To get your hat back, you must climb up one of four block pillars nearest to the vulture. Just wait for him to swoop by and nab your hat back from him again!



SUPER MARIO 64

—by Nintendo
for Nintendo 64

Another way you can lose your hat is on Stage 10. When you walk across the ice bridge in front of the snowman, you can be blown off the edge and lose your hat. Here's how to get it back. Go back into the level and go to near where the first sign is. A snowman will pop up wearing the hat! Just kill him to collect it.



SUPER MARIO 64

SYSTEM: Nintendo 64

PUBLISHER: Nintendo

CHEAT SHEET:

MAD PENGUIN



Once you get the baby penguin to his mother, pick up the baby once again – but this time, the mother will get mad and chase you about her pond.



The first thing that you have to do is get the baby penguin to his mother penguin.



Here's an oddball trick to do on Stage 4. First, get the baby penguin to his mother (see the trick below for a neat, nifty shortcut!) After she gives you the star, pick up the baby again. The mother will take on a mean facial expression and start running after you.

Don't worry, she won't hurt you—just push you about and whine a whole heck of a lot. However, if you leave any distance out of the pond, she will stop and just stare at you. It is a strange sort of trick, but does show off the detail they made in this game.



After you get the star from the mother, pick up the baby once again. The mother will then run madly after you!

SUPER MARIO 64

SYSTEM: Nintendo 64

PUBLISHER: Nintendo

There are a great many fun things you can do with the baby penguin that you find on the top of Stage 4. One of the strangest things you can do is

CHEAT SHEET:

BABY PENGUIN TRICKS



By doing Mario's dive while near the penguin will make him dive as well. Also, there is a great shortcut for getting the baby penguin to his mother.

perform a dive while he is around you. Once you do this, he will mimic you and slide on the ground as well. If you're good enough, you can make him slide with you down the ice slope, but it's very hard to do.

Another tidbit on the baby penguin is a quick shortcut to get right to the mother. Once you grab the penguin, jump off the ledge containing the starting point of the ice slide. The snow will break your fall on the ground, so don't worry about damage. Just pick up the baby again, and then proceed straight to the mother, who shouldn't be too far away from where you will land.



Just jump off this ledge to get the baby quickly to his mama.



Do a dive near the baby penguin to make him dive as well.

TRICKS OF THE TRADE

KILLER CODES
GAME SHARK CODES



by Interact Accessories
PlayStation Codes
These passwords are for use with the Game Shark peripheral for the PlayStation only. They will not work on their own with just the game. Note: Do not try to modify the codes because they are supposed to be entered as shown here:

Bogey: Dead 6 -
Infinite Sidewinders:
800bc6840064
Infinite AMRAAM Missiles:
800bc6860064

(continued on the next trick page)

NEED FOR SPEED

SYSTEM: PlayStation PUBLISHER: Electronic Arts

CHEAT SHEET: LUNAR SPRINGS

POWER TRIP
The easiest way to get the track is to use the password, **SPKSHC** and then choose another mode of play. Then go to Rusty Springs and hold the correct buttons.

This incredible trick will reveal Lunar Springs, which is a track on the moon! There are two ways you can do this. The first way (which is more difficult) is to beat Tournament Mode and get access to the extra track, warrior car, etc. Play the tournament again and beat all of the tracks, including Lost Vegas. Now, select a Single Race, Time Trial or Head-to-Head Mode and go to Rusty Springs. Instead of just holding L1 and R1 for Oasis Springs, hold the Triangle button and then press and hold L1 and R1. You will see the Lunar Springs picture appear! Keep holding these and press START to play on the moon! Another way of doing this trick (which is much easier) is to access the Tournament Mode and enter the password **SPKSHC**. Go back and choose another mode. Then hold L1, R1 and Triangle on Rusty Springs.

Taj Walker, Richmond, VA



Choose a one-player game from the Game Mode Screen.



At Race Type, choose the Tournament Mode option.



In here, enter the password, **SPKSHC** and press **START**.



Pick another race type, go to this screen and hold the buttons.



You can even use the warrior car on this track (hold L1 & R1).

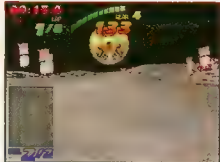

Earth is in the background and you're racing on the moon!

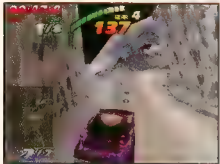

There is a similarity between this track and Oasis Springs.



The gravity on this track can make you lose control

Some day all video games will be this good.
You wish.

WIPEOUT XL

KILLER CODES

GAME SHARK CODES (CONTINUED)

—by Interact Accessories

(PlayStation Codes Continued)

Gunship -
 Infinite Ammo:
 800a429803e7
 800a429a03e7
 800a429c03e7
 800a429e03e7
 Infinite Fuel:
 800a42aa0064

The Hive -
 Infinite Shield:
 8006b5dc1612
 Infinite Thrust:
 800685fc0096

Tokyo Highway Battle -
 Infinite Funds:
 8006d7be0fff

Top Gun -
 Infinite Standard Missiles:
 801cfeca0064
 Infinite AGM Missiles:
 801cfec00064
 Infinite MIRV Missiles:
 801cfec00064
 Infinite Sureshots:
 801cfec00064
 Infinite U238s:
 801cfec00064

Worms -
 Infinite Health P1, Worm 1:
 8014a54c0064
 Infinite Health P1, Worm 2:
 8014a5f80064
 Infinite Health P1, Worm 3:
 8014a7900064
 Infinite Health P1, Worm 4:
 8014a6a40064
 Infinite Health P1, Worm 1:
 8014a7fc0064
 Infinite Health P1, Worm 2:
 8014a8a80064

(continued on next trick page)

BLADEFORCE

SYSTEM: 3DO

PUBLISHER: Studio 3DO

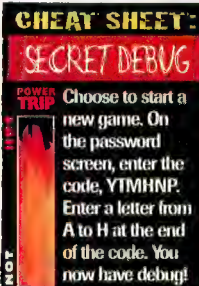

CHEAT SHEET: SECRET DEBUG
POWER TRIP Choose to start a new game. On the password screen, enter the code, YTMHNP. Enter a letter from A to H at the end of the code. You now have debug!

This trick will give you a Debug Mode where you can edit the level you play and more! To do this, go to the Main Options Screen and choose "Start New Game." On the next screen, you will have the options of entering a password or starting your game. Enter this code:

YTMHNP

Now, after the letter P, enter any letter from A to H (A for the practice level in the beginning, B for the first level, C for the second level, etc.). Once you enter the code, choose the "Start Game" option. A Debug



On the Main Options Screen, choose to "Start New Game."



The Debug Menu will appear on this screen. Edit levels!

Menu will appear on the left side of the next screen. You may now create your own level! Press B to cycle through the options, C to execute the selected command, X to play the level and P to exit the Debug Menu.

David Aldarondo
 Bisbee, AZ



Enter the debug code on this screen and then start the game.

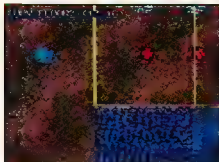

You can choose your texture, add walls, paste pallets, etc.

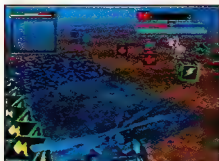

Once you're finished editing, you can play your new level!

GUN GRIFFON

SYSTEM: Saturn

PUBLISHER: Game Arts

This trick will give you unlimited ammunition for your main gun only. To do this cheat, get to the Title Screen and when the words "Press Start Button"

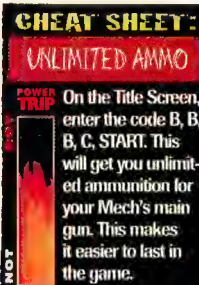

CHEAT SHEET: UNLIMITED AMMO
POWER TRIP On the Title Screen, enter the code B, B, B, C, START. This will get you unlimited ammunition for your Mech's main gun. This makes it easier to last in the game.

appear, enter B, B, B, C, then START on the first-player controller. When switching weapons around during the game, you will notice that all of your other weapon's ammunition goes down, but the main gun ammo will not deplete. This will make it easier to survive in a difficult game such as this one.

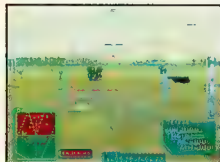

Normally in the game, you will run out of main gun ammo.



At the Title Screen, enter B, B, B, C, then START on controller 1.

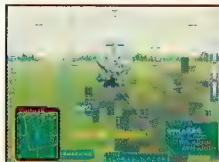

Now your main gun will have plenty of ammo with the code.

TRICKS OF THE TRADE
KILLER CODES
GAME SHARK CODES



—by Interact Accessories

Saturn Codes

These passwords are for use with the Game Shark peripheral for the Saturn only. They will not work on their own with just the game. Note: Do not try to modify the codes because they are supposed to be entered as shown here:

Ghan War -
 Master Code:
 f606b124c305
 b60028000000
 Infinite Lives:
 160948F03C64

(Continued on next trick page)

TETRIS ATTACK

SYSTEM: Super NES PUBLISHER: Nintendo

CHEAT SHEET:

SPECIAL STAGE



Pick a one-player game, Stage Clear, and enter the password: X6G!NJ45. Bowser will beckon you to fight him in a very unfair match to the death!

To get the special stage, choose a one-player game, Stage Clear, enter this password: X6G!NJ45 and then



In the Stage Clear option, enter the password as shown.

choose "End." A secret stage with Bowser will interrupt your game. Fight him to the death!

Kyle Toyama; Los Angeles, CA



Fight a near-impossible match with Bowser on his stage!

TETRIS ATTACK

SYSTEM: Super NES PUBLISHER: Nintendo

CHEAT SHEET:

SUPER HARD MODE



In the one-player, VS. mode, start a new game. At the Set Level screen, highlight "Hard" and hold UP+L1. While holding these, press the A button.

For a super hard mode, choose a One-player game, Vs. Mode. Then select the New Game option. At the Set

Level Screen, highlight the "Hard" Level. Then use controller L1 and press and hold UP+L together. With these held, press the A button. The lower portion of the screen will turn red. Now, the first opponent will be almost as difficult as the Boss!



Highlight the Hard Mode and do the trick with controller L



The bottom portion will turn red. Now the game is even harder!

Other "futuristic racing games" aren't WipeOut XL.
 Obviously.

WIPEOUT XL

KILLER CODES

GAME SHARK CODES (CONTINUED)

—by Interact Accessories

(Saturn Codes Continued)

Legend of Oasis -

Master Code:
f6000914c305
b60028000000
Infinite Health:
16088da20ff0
Infinite Magic:
16088da60fff
Bow:
160887200009

Primal Rage -

Master Code:
f6000914c305
b60028000000

Infinite Health P1:

160f9a3a0000
160f9f980000

Infinite Health P2:

160f9a4c0000
160f9ace0000

ULTIMATE MORTAL KOMBAT 3

—by Williams Entertainment for Saturn

Here are some Kombat Codes that will make some pretty cool matches. You must enter these very quickly at the Vs. Screen in a two-player match. The first three symbols must be entered with buttons A, Y and C on controller 1, and the second three symbols must be entered with buttons A, Y and C on controller 2. Press the button the number of times shown for each symbol:

PUBI: D.K.P.: 300-003

(continued on next trick page)

TETRIS ATTACK

SYSTEM: Super NES

PUBLISHER: Nintendo

CHEAT SHEET:
MORE CHARACTERS

At the Character Selection Screen, press and hold the top L and R buttons on both of the controllers.

Pick a two-player, Vs. Mode game. When you are on the Character Selection Screen, take controller 1 and press and hold the top L and R buttons. While holding these, take controller 2 and press and hold the top L and R buttons. The four bottom boxes will fill up with Boss characters instead of question marks!

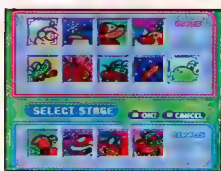

You can play as the Bosses and Bowser with this code!

INTERNATIONAL TRACK AND FIELD

SYSTEM: PlayStation

PUBLISHER: Konami

CHEAT SHEET:
BIKINI CODE

On the Game Select Screen, highlight the 100m Free Style event and press UP, UP, DOWN, DOWN, LEFT, RIGHT, LEFT, RIGHT, Circle, X for the bikinis.

At the Game Select Screen, highlight the 100m Free Style event and press UP, UP, DOWN, DOWN, LEFT, RIGHT, LEFT,

RIGHT, Circle, X. When the event begins, the swimmers will be wearing bikinis instead!

— via the Internet



At this screen, highlight 100m Free Style and do the trick.



Instead of the normal bathing suits, they'll have on bikinis!

SKELETON WARRIORS

SYSTEM: PlayStation

PUBLISHER: Playmates Interactive

CHEAT SHEET:
INVINCIBILITY

In the middle of the game, press START to pause. Now press DOWN, Circle, Square, Square, UP, X. Then press START to un-pause. You will be invincible.

Square, UP, X and press START again. Once you un-pause the game, your player will be transparent. This shows that the trick worked. You may now walk through enemies, etc. and not be hurt. You must, however, destroy many of the skeletons who get in your way, to get past certain sections of the levels.



In the middle of the game, press START and do the code.

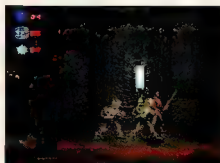

When you un-pause, you will be flashing and invulnerable.



Walk through enemies and you won't be hit (kill them, though).

KILLER CODES

ULTIMATE MORTAL KOMBAT 3

(CONTINUED)

—by Williams Entertainment for Saturn

- P.A.B.: 200-002
- Skunky!! E.F.: 122-221
- Player 1 inflicts half damage: 390-000
- Player 2 inflicts half damage: 000-390
- Both players inflict half damage: 390-390
- Combo System Disabled: 722-722
- Super Run Jumps: 321-789
- Special moves disabled: 555-556
- Regenerating power bars: 975-310
- Real Kombat: 040-404
- Super Endurance: 024-689
- Throws Disabled: 100-100
- Blocking Disabled: 020-020
- No Life Bars: 987-123
- Half Energy for Player 1: 033-000
- Half Energy for Player 2: 000-033

(continued on next trick page)

PILOTWINGS 64*

SYSTEM: Nintendo 64 PUBLISHER: Nintendo

CHEAT SHEET:

JUMBLE HOPPER SHORTCUT

POWER TRIP
NOT
NOT
NOT

To do this trick, you must be in Jumble Hopper 3. Follow the pictures and descriptions shown below to figure out the method for this great shortcut.

First, you must get to the third stage of the Jumble Hopper event. When you begin this stage, jump between the building you start on and the building in front of your starting position. The aim is to get through the doorway of the bluish-green building. This is best done by jumping against the building across from it, and landing right next to the open doorway. This is very difficult to do and requires a lot of practice. Once you have mastered this, you will be able to jump into the hallway (with much difficulty) and follow the path until it leads out into the street. Once you reach the street, you will notice that you have warped into New York! This is not very far from the goal. If you are good enough, you will be able to get a near-perfect score (depending on how many points were taken off during your journey).

- via the Internet



Get access to the Jumble Hopper 3 event for the trick.



Your first goal is to get to the bottom of this building.



Use the building in front of it to bounce you close to the entrance.

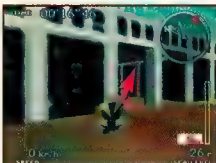

Once you are near the entrance, see if you can jump into it.



Once you're in, follow the path. You'll locate an N64 logo!

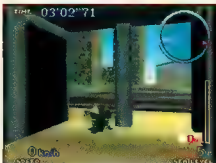

Finally, you will reach the exit on the other side.



You will be warped to New York; not far from your goal.



Now you can get to the goal with a high score if you're careful!

*This trick was done on a Japanese version of the game and is subject to change.

There are other video games that you could buy.
 Like you care.

WIPACOLT XL

KILLER CODES

ULTIMATE MORTAL KOMBAT 3 (CONTINUED)

—by Williams Entertainment for Saturn

- Quarter Energy for Player 1: 700-000
- Quarter Energy for Player 2: 000-707
- Dark Kombat: 688-422
- Text - No Fear: 282-282
- Text - Hold Flippers: 987-666
- Quasi-Randper Kombat: 460-460
- Multimode: 985-125
- Unlimited Run: 466-466

Andy Schlei
Mason City, IA

WORMS

—by Ocean for PlayStation

Now you can have access to the Banana Bombs, Sheep and Minigun with a simple code! Just enter the Options Screen and go into the Weapon Options. Once there, move the cursor so it is not touching any word on the screen and then press the X and Square button together seven times. The options will change to give you access to these new weapons! Also, the Ninja Rope is much easier to manipulate. You will have no problem getting over ledges and cliffs if you just bounce high enough.



GOLDEN AXE: THE DUEL

SYSTEM: Saturn

PUBLISHER: Sega

CHEAT SHEET:
SECRET SELECT MODE

POWER TRIP Play a Vs. Mode match. Once it's over, pause and press the L button to get a Character Select Mode. Use this to get to the next match much faster.

NOT

Select the Vs. Mode and then choose your characters. Once the match is over, and the computer counts the points you earned for Life, Time, etc., press START and then press the top L button. A menu will appear in the upper-middle of the screen which shows player one and two's character names. Cycle through the names for each player until you reach the ones you want to pit against in the next match. Once you do this, press the top L button again and then press START again to unpause the game. After the game is done



Select your characters to battle each other in the Vs. Mode.



Once the match is over, wait until the points are being tallied.



Pause and press the L button. Choose your characters.



Next, you'll get the Now Loading Screen to appear.

tallying the total points, it will go to the Now Loading Screen. But instead of going to the Select Players Screen, it will go straight to the match with the characters you choose earlier in the menu! This is a great way to surpass a lot of unneeded load time and get right to the next fight!



The characters you choose will be in the next match!

CLOCKWORK KNIGHT 2

SYSTEM: Saturn

PUBLISHER: Sega

CHEAT SHEET:
CONTROL THE LEVEL-ONE BOSS

POWER TRIP When the spotlight appears, take pad 2 and press LEFT, RIGHT+B+C, RIGHT+B+C. Use the directions below to control the Boss's movements as shown.

NOT

As soon as the Snake Boss appears and the spotlight comes on, press LEFT, RIGHT+B+C simultaneously, RIGHT+B+C simultaneously on controller 2. The controls



When the spotlight appears, do the trick on controller 2.



Using controller 2 you can manipulate its moves and sounds!

for the Boss are as follows: The D-pad LEFT or RIGHT to move in those directions; D-pad UP or DOWN to make the Boss closer or farther away; Z and C to move the Boss up and down; A, B, Y, L and R to have the Boss make noises; X to make the room light go on and off; START to fight again.



When you're done, press START to give control back to the computer.

• via the Internet

KILLER CODES

WORMS

—by Ocean for PlayStation

There are many landscapes in this game that are randomly generated. Fortunately, you can have control over which ones you want by entering codes. Start a match and when the game starts generating a landscape, press the X button to clear the current code. Move UP or DOWN to change the letter or number of the current code to the one you want. Try any combination of words and numbers you want. Here are a few of Trickman Terry's favorites:

- 29726 (Long Bridge)
- TRICKMAN
- EGM RULES
- WORMS RULE



RESIDENT EVIL

SYSTEM: PlayStation PUBLISHER: Capcom

CHEAT SHEET:

STRANGE METHOD

POWER TRIP
DO NOT

Follow the method shown below to see another way that this game can begin. Supposedly, the game is easier after you do it, but this has not been confirmed.

Start a new game as Jill. After you and Barry enter the dining room, return to the foyer. Wesker will tell you to investigate shots. The game will return you to the dining room. Turn back to the door and try to go through. Barry will say, "Lost courage already? That's not like you." Move to the blood stain and look at it. Barry will talk like normal. Go in front of the grandfather clock. As soon as you do this, a zombie will appear from the other room and chase after Jill. Barry will kill the zombie and use a curse word. Return to the foyer with Barry. In the cinema that follows, Barry will give you a lockpick. Now go to the scene where the zombie was previously eating Kenneth (in the hall next to the dining room) and you will see that he has no legs and no clips to pick up. The game is supposedly easier now.

Ryan Allen; Tallahassee, FL



When starting a new game, choose Jill to make it work.



Go into the dining room and then back into the foyer.



Wesker will tell you to investigate any shots fired.



If you try to go out again, Barry will question your actions.



Go by the grandfather clock and a zombie will go after Jill.

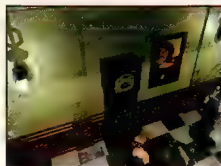

Barry will kill the zombie and then use a curse word.



Barry will give you a lockpick in the foyer. Go back in.



In the hall, Kenneth will appear without legs or clips!

WIPEOUT XL

Brace yourself.

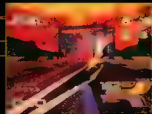



PlayStation



Sierra Interactive, Lara, Tomb Raider, Lara Croft and her likeness are trademarks of Sierra. P.S. ©1997 Sierra.

**YOU KNOW HOW IT REALLY HURTS TO GET KICKED
RIGHT BETWEEN THE LEGS? WUSS.**

**TOMB
RAIDER**

EIDOS
INTERACTIVE

COMING SOON



MACHINE HEAD

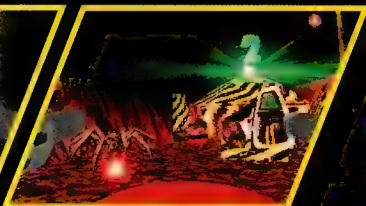
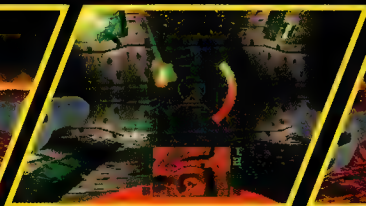

COMING SOON PlayStation Saturn



Machinhead, Core, and Eidos Interactive are trademarks of Eidos, Pk. ©1996Eidos.

EIDOS
INTERACTIVE

Reach out and crush someone.

Coming soon.



EIDOS
INTERACTIVE



PlayStation and
Eidos with permission

Marvel Comics
© 1996 Marvel

PlayStation
Eidos

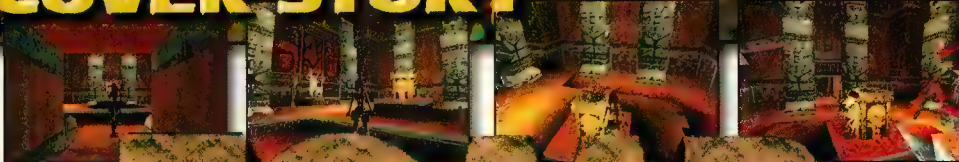

TOMB RAIDER

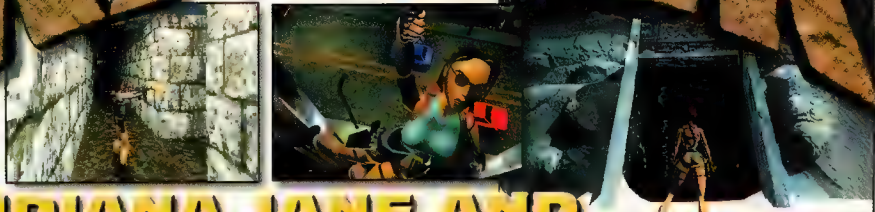

INDIANA JANE AND HER NEXT-GEN CRUSADE

It's probably not a good idea to get on Lara Croft's bad side. After all, the buff and beautiful hero of Eidos Interactive's 3-D action game *Tomb Raider* has a four-foot vertical leap, can shove around gigantic stone blocks like they were paper weights and is a dead-aim with her shotgun—even when in mid-backflip.

And the game in which she stars is even more impressive. *Tomb Raider*, which is coming in November for both the PlayStation and the Saturn, is one of the few recent titles forging their own genre—the exploration game. Just as in *Super Mario 64* (and, to some extent, *Perfect*

Weapon) *Tomb Raider*'s fun doesn't come from blowing away bad guys. Instead, players will want to investigate every nook and cranny of the game's 12 cavernous environments—a task that could easily take weeks.

Playing *Tomb Raider* is like visiting the Egyptian pyramids or a Mayan temple, then crossing the red, felt-covered ropes that keep tourists from becoming true explorers. The game's levels are dispersed throughout the world, allowing Lara to explore Incan temples, an ancient Greco-Roman coliseum, Egyptian ruins and even the lost city of Atlantis.

Each of these locations looks like the

real deal—as if they were ripped straight from the pages of a history-class textbook. Cracked columns tower over the coliseum (which is infested with ravenous lions, by the way), broken sculptures of ancient gods line the hallways of the Incan Temple and faded hieroglyphics decorate the walls of the Egyptian ruins. (Note: Although the screenshots on these pages were taken from the PlayStation version of *Tomb Raider*, the scenery and structures in the Saturn version look the same.) Since these levels are all found underground, they're surrounded by rock formations that Lara can climb and rivers she can swim in;

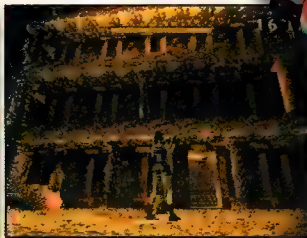
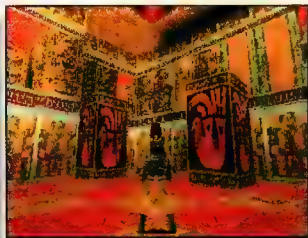
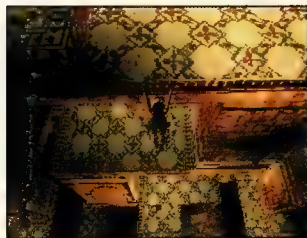

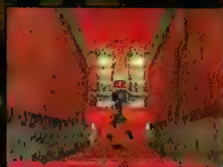
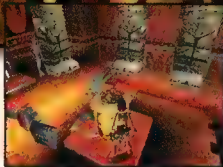

the game's just one big subterranean playground.

But Tomb Raider's world isn't without its dangers. As Lara goes about her quest to find three pieces of an ancient Atlantean artifact, she'll face a zooful of not-so-friendly animals. Everything from gorillas to crocodiles to vampire bats roam the darkened corridors of the game's ruins, and they love to

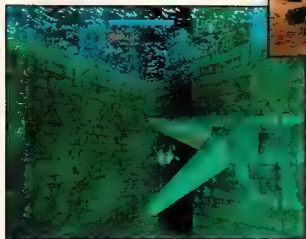
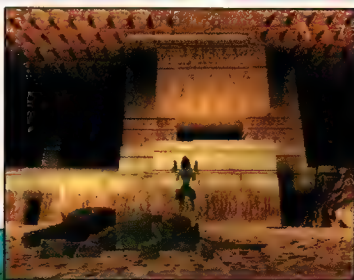

devour all human trespassers.

The animations for these polygon animals look very true-to-life, too. When Lara walks into a room full of sleeping wolves, for instance, they perk up from their sleep, stare at the heroine then leap straight for her jugular. And the animation for the chest-

pounding apes is downright frightening.

Besides the beasts, Lara will have to contend with *Indiana Jones*-inspired traps and dozens of puzzles. Most of the puzzles require Lara to time her leaps and flips so she lands on ledges leading to new areas, while others have her pushing around blocks or pulling switches in the right order.

Of course, it takes more than a few sharp-toothed critters and traps to scare Lara Croft. Besides her acrobatic abilities (see sidebar), she wields two handguns to deal with the game's wildlife. And as she progresses through each underground region, Lara comes across uzis, a shotgun, grenades and other high-powered armament.

Considering Lara's tough-as-nails persona, maybe Sega and Sony shouldn't bank too heavily on animal mascots in their war against the Nintendo 64. Perhaps Lara Croft is the real Mario killer. ■

SHADES OF INDY

Sure, *Indiana Jones* had a few close calls during his celluloid adventures, but Lara Croft's life isn't any easier. In fact, many of the traps and artifacts in *Tomb Raider* would look familiar to the whip-wielding archeologist. Tread carefully.

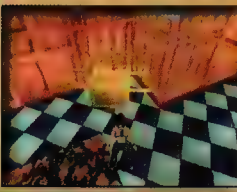
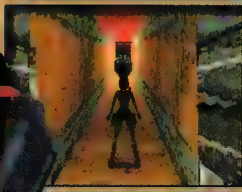

LARA CROFT'S TOTAL BODY WORKOUT

Lara Croft's list of moves may not be as long as Mario's, but her leaps and flips still put most Olympic gymnasts to shame. One level in *Tomb Raider* is a mansion where Lara can practice and show off her acrobatic prowess. Here's a look at some of Lara's more spectacular moves.



Backflip



Sideflip

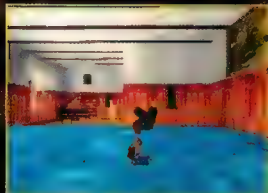

Tumble



Hand-Over-Hand Shimmy



RPG SPECIAL FEATURE

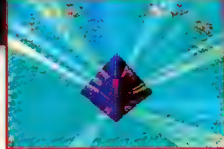
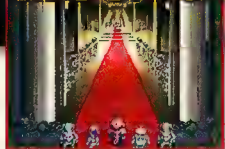

PLAYSTATION GAMERS DEMANDED THEM. NOW...

HERE COME THE RPGS

RPG fans can get a bit fanatical about their favorite game genre. They'll cancel their appointments, miss meals, skip showers and do whatever else it takes to stay lodged in front of the television to play the latest Final Fantasy, Zelda, Breath of Fire or other adventure game.

But if RPGs are an addiction, PlayStation owners have missed their fix. Soon after the launch of the 32-Bit system, Sony made it clear it wasn't interested in seeing RPGs released in the PlayStation's U.S. market. Driving, flying and fighting games would reign in the States, Sony deemed.

Well, many PlayStation owners weren't too happy with Sony's anti-RPG stance. They posted comments voicing their outrage on the Internet and wrote equally outraged letters to *EGM*. They demanded that U.S. gamers shouldn't miss out on what is, after all, Japan's most popular genre of games. Besides, they figured, the PlayStation packs enough power to pump out some of the greatest RPGs ever. Why waste the system's potential?

Sony apparently got the message. It's now releasing the Japanese RPG Beyond the Beyond (with Arc the Lad on the way), and soon Stateside PlayStation gamers will face a flood of adventure games.

Some of them are traditional, Final Fantasy-style RPGs, while others are more action-oriented, Zelda-style titles. And one looks likely to be the greatest console RPG of all time, Final Fantasy VII, which Square will release by the summer of next year (and by December in Japan).

What follows is a look at the looming tidal wave of PlayStation RPGs. Some are still early in development, while others are nearly complete and no doubt top many Christmas wish lists, but all will feed the appetites of RPG-starved PlayStation gamers.

(Saturn owners don't fret—look for a guide to RPGs for your system next issue!)

BLOOD OMEN: LEGACY OF KAIN

The more than 120-hour-long quest in Crystal Dynamics' *Blood Omen: Legacy of Kain* seems a little out of place in a console RPG. It doesn't center on a big party of characters, lost princesses or ruined kingdoms. Rather, it is a dark tale of one vampire's journey through an even darker world full of undead monsters and terrorized peasants.

Players control a vampire who roams the world on a quest to become a normal, mortal human again. Along the way he'll battle Bosses with god-like powers, chug the blood of dozens of peasants and mon-

sters and eventually save the world.

Legacy of Kain plays very much like a *Zelda*-style RPG, with Kain using a variety of weapons to hack in realtime battles through the game's army of thugs and undead monsters. The game also yammers out hours of well-acted dialogue and rendered cinemas.

But what players will really remember is the huge amount of blood and guts that is spilled throughout the game. Its rivers of gore and epic story make *Legacy of Kain*, a game all die-hard RPG fans will want to sink their teeth into.

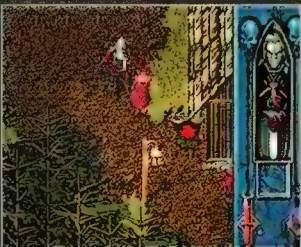
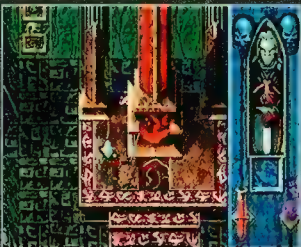
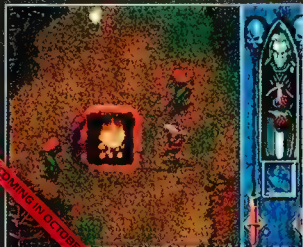

ARC THE LAD I & II

More than 400,000 Japanese gamers have already played Arc the Lad—one of the first PlayStation RPGs—and now the game is finally on its way to America.

Sony's Arc the Lad offers a mixed bag of traditional console RPG elements. Some of the game's locations are viewed from an overhead perspective, while others are seen from a three-fourths or heads-on view. Combat is also a bit different. Rather than being randomly ambushed by monsters, you walk your individual fighters across the battlefield and up to

their opponents to engage them in turn-based battles.

Perhaps the game's most stunning feature is its music. The London Royal Philharmonic Orchestra recorded Arc the Lad's soundtrack, and the soaring score brings to the game an epic feel.

U.S. gamers may get more than they bargained for when Arc the Lad comes

out in the States. Rumor has it that it might come packed with its sequel, the aptly named Arc the Lad II. Unlike most console RPG sequels, Arc the Lad picks up right where the original left off. In fact, once you finish the first game, your progress is saved to a memory card. This save point is used to kick off the second adventure.

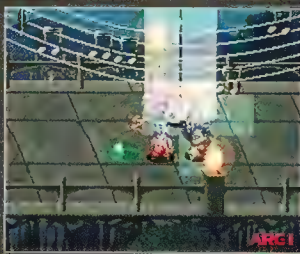
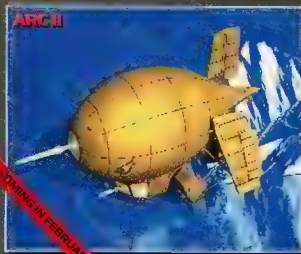

SUIKODEN

With a cast of more than 100 characters—all of them mired in a bloody civil war—Konami's Suikoden promises to be both an epic and bloody RPG. This combat-filled title, which has been out for a while in Japan, features a combination of sprite-based and 4-D texture-mapped graphics, as well as a fully orchestrated musical score.

Your goal is to assemble an army

powerful enough to topple the evil Red Moon Empire. But putting together your rebel force will take some strategy, since you have a variety of troops to choose from. You can recruit engineers to build weapons, merchants to supply goods, farmers to grow food—even



musicians to entertain the troops. Battles themselves are played out in a grander scale than those in most RPGs. You can either enter one-on-one, party-vs.-party or army-vs.-army battles.

During your quest, you'll have to fight your own father and deal with turmoil among your own troops—all while being surrounded by the death and destruction of full-blown war.

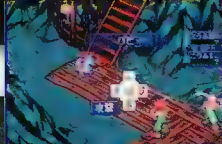
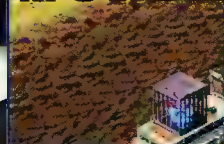

BREATH OF FIRE 3

RPG fans who played the first two Breath of Fire games on the Super NES may not recognize the third installment of the series. That's because it's coming out for the PlayStation, and the game is played entirely in a richly detailed 3-D environment.

If you can ignore Final Fantasy VII, Breath of Fire 3 is by far the best-looking of the new batch of PlayStation RPGs. Playing the game is like playing a



conventional, three-fourths-perspective RPG, except the graphics can be rotated around the main, sprite-based characters to uncover hidden enemies and secret passages. This ability to shift the camera's view makes the environment more interactive with the adventurers. Now players have to pay attention to the scenery rather than just walk through it.

Breath of Fire 3's plot isn't a continuation of the previous games, although it is set in the same world of Dragon Clans and evil super beings. Players control Ryu, a young man with a very strange childhood. It seems that Ryu was once a baby

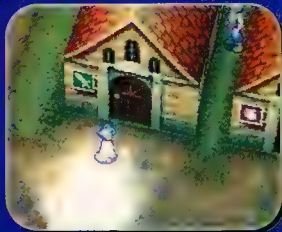

Twisted Views

Not all of Beyond the Beyond's treasures and characters lie in plain sight. Sometimes they are hidden away between buildings or bushes, and players have to swivel the camera

perspective to find them. This interaction with the surroundings gives players the feeling of traveling through a true 3-D world—one that players are going to have to search carefully.

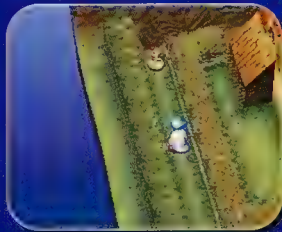
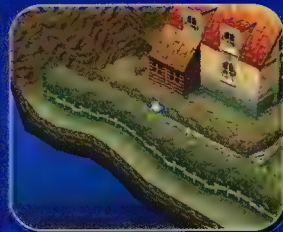

dragon. The game opens with a couple of miners stumbling across Ryu in his tiny dragon form. Ryu is encased in a gem, and the miners blast him free. They

capture the baby dragon and put him on a train, but he shakes his cage off the train and escapes. He turns into a little boy and is adopted by a family in a village.

Ryu spends the rest of the game trying to figure out who he is and where he came from. His quest will take him across oceans, over deserts and through forests as he learns how he is related to the legendary Dragon Clan.

Besides its spectacular 3-D graphics, Breath of Fire 3 plays much like other RPGs. It's loaded with cut scenes, battles are turn-based, and Ryu (and the other characters who join him in his quest) can use a variety of magic attacks and weapons. Still, Breath of Fire 3 is the first RPG to take full advantage of the PlayStation's polygon-crunching power.

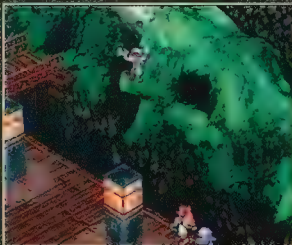



PROJECT
OVERKILL

IT'S READY-ARE YOU?



www.konami.com

©1998 Konami Publishing Co. All rights reserved. All trademarks of Konami, Inc. and PlayStation™ and the PlayStation™ Family logo are trademarks of Sony Computer Entertainment, Inc.

KING'S FIELD 2

The first King's Field was more a medieval version of Doom than a role-playing game, but—what the heck—it was close enough to an RPG for its sequel to be included in this feature.

King's Field 2 (actually, it's King's Field 3 in Japan), plays much like its prequel, with you wandering through the game's enormous indoor and outdoor environment. But this time that environment is much larger. ASCII has added more villages, a large countryside and other outside scenery—like trees and houses—to the game, as well as more townspeople and monsters. Fans of the first game will also be happy to know that their character in

King's Field 2 moves a lot faster through the game's world than he did in the original. The character's turn rate is also much faster.

The game's quest is longer, too. Players must search for the Five Powers that will save the world from being swallowed by evil. Townspeople and other characters will occasionally offer hints (courtesy of digitized voice-overs) to guide players through the game.

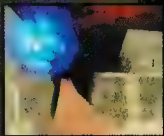
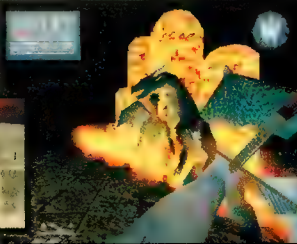
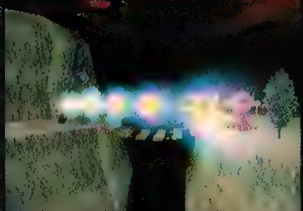

ARK OF TIME

Unlike most adventure games, Ark of Time isn't set in some other dimension or medieval land. Instead, the game's quest takes place right here on good ol' Earth. Players guide Richard, a newspaper reporter who's out to discover what happened to a missing professor. Before he vanished, the profes-

sor was searching for the lost city of Atlantis, and soon Richard gets caught up in that quest as well.

Richard's adventure will span the globe and take him to some of the world's more mysterious locales. He'll

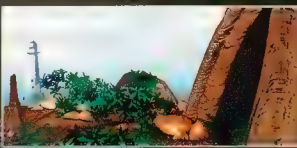
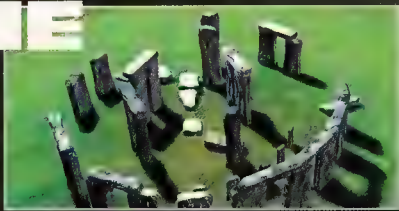

check out Stonehenge and Easter Island, explore a Mayan temple in Mexico, delve into a tomb below a medieval church and even dive to the ocean floor. As he travels, Richard will stumble upon artifacts that will unravel the mystery surrounding the fate of Atlantis.

FINAL FANTASY TACTICS

Okay, so Final Fantasy Tactics is more of a strategy game than an RPG, and it's not yet known whether the game will come out in the States, but this title just looks too cool to ignore. FF Tactics takes the beasts and characters from the Final Fantasy series (look for soldiers riding Chocobos) and

pits them against each other on a 3-D battlefield.

FF Tactics is designed to be more fun than complicated. Square has taken out the more time-consuming elements of traditional strategy games, while still keeping the game true to its genre.

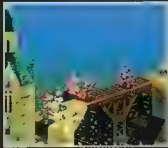
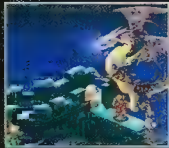

They beat you senseless.

They kidnapped your partner.

They stole your spaceship.

It's Payback Time.

THE DIVIDE: ENEMIES WITHIN™

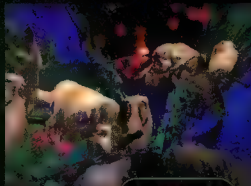

Over 24 types of vicious enemies and 12 diabolical bosses



Game art shown is from the PlayStation™ Game Console

You wake up from an eons-long sleep only to find yourself on a forsaken planet filled with angry mutants. You've got to outsmart them, outblast them, and escape from this hell hole once and for all.

Power-up, my friend.

You'll be here
a while.

The Action/Adventure game
brought to you in true 3D



Ten deadly weapons and 15 butt-kicking power-ups



Eight incredible 3D worlds with 50 realistic stages

Coming soon for

PC
CD-ROM



Play this game at
www.viacomnewmedia.com

Call (800)-469-2539 to order

Radical
ENTERTAINMENT

VIACOM
newmedia™

RATING PENDING
RP

© 1996 Viacom International Inc. All Rights Reserved. Viacom New Media, The Divide: Enemies Within and all related titles, logos and characters are trademarks of Viacom International Inc. PlayStation and the PlayStation logos are trademarks of Sony Computer Entertainment, Inc.

TO POKE? OR TO BLUDGEON & DISEMBOWEL.

SOME FARMER WITH A STICK
GIVING YOU A ONCE OVER?

OR AN ARMORED KILLING
MACHINE SPLITTING YOUR SKULL
OPEN WITH A RUSTY MACE.



ADVANCED DUNGEONS & DRAGONS, RAVENLOFT and the TSR logo are registered trademarks of TSR, Inc. IRON & BLOOD and WARRIORS OF RAVENLOFT are trademarks of TSR, Inc. © 1996 TSR, Inc. PlayStation and the "PS" logo are trademarks of Sony Computer Entertainment, Inc. Sega and Sega Saturn are trademarks of SEGA ENTERPRISES, LTD. All rights reserved. Acclaim is a division and registered trademark of Acclaim Entertainment, Inc. © & © 1995 Acclaim Entertainment, Inc. All rights reserved. Screenshots shown are taken from the PlayStation version of the video game.

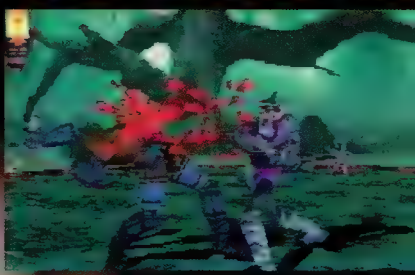

Advanced **Dungeons & Dragons**

IRON & BLOOD

WARRIORS OF
Ravenloft

225,000 POLYGONS
PER SECOND ACTION

11 GOTHIC ARENAS

16 CREABLE CHARACTERS

OVER 64 WEAPONS AND
250 BRUTAL MEDIEVAL
COMBAT MOVES

HEAD-TO-HEAD
TOURNAMENT AND
TEAM CAMPAIGN MODES

BLOOD & GORE GALORE

THE DARK SIDE OF 3-D FIGHTING

PLAYSTATION™ SATURN™ DOS CD-ROM

www.acclaim.com

Acclaim
entertainment inc

FINAL FANTASY VII

If you own a PlayStation and you're into RPGs, don't make any plans for next summer. That's when Final Fantasy VII is coming to the PlayStation, and this—the latest (and what looks to be the greatest) installment of Square's immensely popular Final Fantasy series—is going to keep gamers adventuring for a long time.

Square's developers haven't been bragging their feet since the company announced that FF7 would be coming to the PlayStation; more than 100 programmers and artists have been working on the RPG. Although Square plans to release the game in Japan in December, Japanese gamers have already tasted the FF7 experience. Packed with each copy of Total No.1—Square's first fighting game—is a playable, 20-minute demo of FF7. The demo dropped jaws when played in EGM's offices, and it gave the editors a good idea of how the finished masterpiece will play and look.

When boiled down to its essentials, FF7 plays much the same as its Super NES and Super Famicom predecessors. The turn-based battles still flare up mostly at random, and they're kicked off by the same screen-smearing effect that has always heralded combat in Final Fantasy games. The standard menu commands are found at the screen's bottom and laid out in the familiar format. In fact, the gameplay is so familiar that the non-Japanese-speaking members of EGM's staff had no problem figuring out FF7's



menus and playing through the demo.

But the game's look (and sound—the orchestrated music is phenomenal) is a different story. As reported earlier, FF7 drops real-time polygon characters into a 3-D, prerendered world. Square's artists used state-of-the-art SGI workstations to render FF7's environments, which are extremely sharp and detailed. And game

characters can move between and behind buildings and structures to give the landscape the illusion of being truly 3-D.

Every aspect of the game is also highly cinematic. Cut scenes send the camera zooming in on the party or panning across the landscape, so the game might be viewed from an overhead perspective one minute and a ground-level, heads-on view the next. Battles are watched from four switching camera angles, each panning



COMING SUMMER '97

Cinematic Magic

and zooming to give the combat sequences a straight-from-a-movie look.

The game's stunning visuals are precisely the reason Square decided to develop the game for the PlayStation, since only CDs are capable of holding the huge amounts of data needed to create FF7's huge world. (Incidentally, that world will fill two CDs.) But the use of CDs raises a concern: Will load times bog down FF7?

Square officials say no. "This is actually real-time gameplay," a FF7 developer in Japan told *EGM* editors. "The loading time is just as fast as on the Famicom games." Sure enough, the FF7 demo never slowed or showed a hint of load delay once it was up and running.

FF7 is set in a world that appears to be

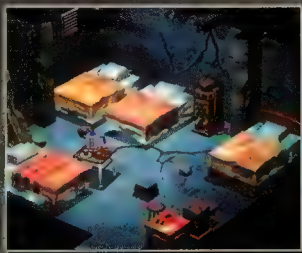

a bit more technologically advanced than the heavily industrialized world of FF3.

Players will guide their party—which might include as many as 10 characters—through run-down cities, trainyards, fortresses, power plants and other dingy locales. They'll also run into familiar Final Fantasy beasts and vehicles, such as Chocobos and airships.

Unfortunately, U.S. gamers will have to wait until next summer to explore the game's world—the only bright side being they'll have plenty of PlayStation RPGs to play in the meantime. Of course, FF7 looks like it will top them all.

It's going to be a long year.

If players saw nothing more of FF7 than the magic attacks used during battle sequences, they'd still be pretty darn impressed. Spells are shown from the same four camera views that follow weapon attacks during combat. But extra-haty spells, like the summoning

of an Esper (shown in the sequence below), are especially dramatic. The game camera zooms in on the serpentine Esper, then it focuses on the doomed enemies, then it switches to a distant view to show the beast's tidal wave consuming the bad guys.

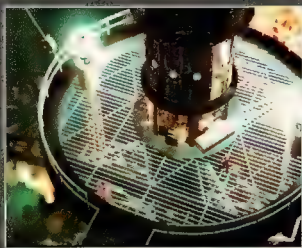
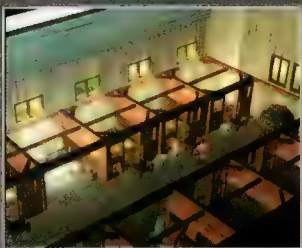
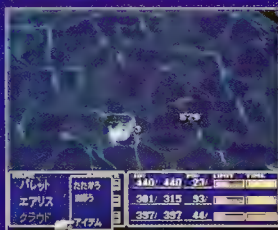
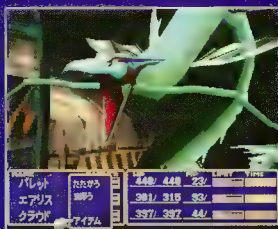
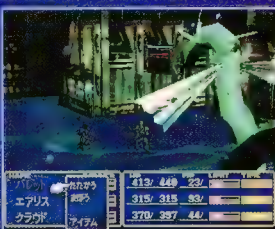
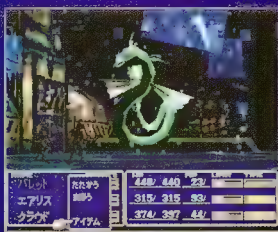



**AFTER HEIHACHI WAS DEFEATED IN THE FIRST TEKKEN
TOURNAMENT, HIS RIVALS THREW HIM OFF A CLIFF.**

THEY SHOULD HAVE FOUND A STEEPER CLIFF.





Heihachi is Heihachi. He has trained high in the mountains - energized by lightning bolts that have struck his massive frame. Practicing his Lightning Hammer Head Crusher on his pet bear. Planning the murder of an evil arch rival - his son Kazuya.



Heihachi Mishima. One of 23 of the world's greatest fighters vying for the title in Tekken 2™. With three new fighting modes. 23 new stages. Brand new 3D animations, and more new moves and combos than any game on Earth. Heihachi is back. And he wants revenge.



POWERED BY
namco

www.namco.com



鉄拳
TEKKEN 2



THE GREATEST FIGHTERS ON EARTH™

BEYOND THE BEYOND

Sony is finally releasing *Beyond the Beyond*, and thousands of PlayStation-owning RPG fans are shouting, "It's about damn time!" This long-awaited title is the first true RPG to come out for the PlayStation (no, *King's Field* doesn't count), and its release brings relief to gamers who feared Sony wasn't too keen on games that lacked constant action.

Beyond the Beyond is about as traditional as console RPGs get (meaning it plays very much like a *Final Fantasy* title). The adventure takes place in an overhead perspective, with players guiding a party of tiny characters through towns, wilderness, the underworld and across the sea. The game's plot, which is as convoluted as anything from Square, opens in the tiny



village of Isla. Here, the player's character is being trained by his father, Sir Kevin, to become protector of the kingdom of Marion. It seems that Marion has some nasty neighbors—namely, the war-mongering Bandore Empire—and skilled soldiers are in short supply.

Marion's situation goes from bad to worse early in the game. Bandore's soldiers attack and take over the kingdom,

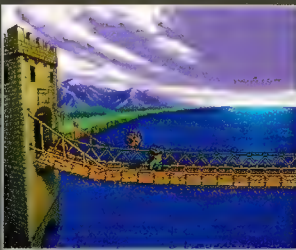
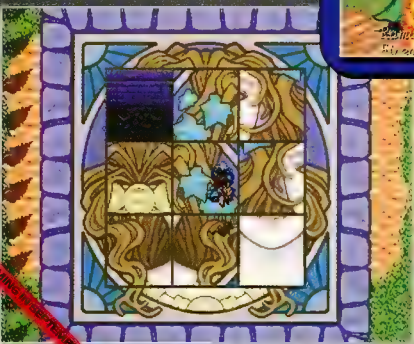

"I've heard the legend of the Flying Palace, but I never thought I would see it!"

Super Spells

An RPG just isn't an RPG if it's not loaded with magic. Luckily, *Beyond the Beyond* is filled with way-cool spells, from the traditional Fire and Ice attacks to the more spectacular Beast Summonings and

Doomsday Spells. In fact, magic strikes are one of the few parts of the game that take advantage of the PlayStation's abilities. Here's a look at the game's more spectacular, screen-filling spells.

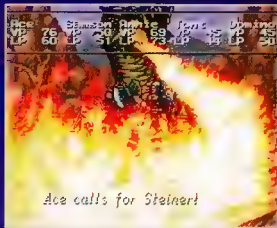
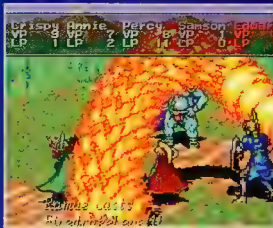

and Sir Kevin winds up missing. The hero's goal becomes pretty simple: He must find his father and help win Marion back from the Bandore Empire.

As the hero searches the land for help in defeating Bandore, he learns that there's more to the evil empire than meets the eye. It turns out that Bandore is

receiving aid from the underworld, a region populated with sinister wizards that lies predictably enough, beneath Marion and the rest of the land. Now, the hero has to deal with this more powerful menace, and his quest changes from saving Marion to saving the world.

Fortunately, players won't have to go about this monumental task alone. The hero's party can contain as many as five people, and the land is full of folks who aren't too happy with the Bandore Empire. As players progress through the game, they'll run into healers, wizards,

IT'LL BLOW YOUR *%#@#?& MIND!



Distributed by:



© 1994 Fox Interactive Inc. "Die Hard Trilogy" © 1994 Twentieth Century Fox Home Entertainment, Inc. All Rights Reserved.
"Twentieth Century Fox" and their associated logos are the property of Twentieth Century Fox Film Corporation.

DIE TRILOGY HARD

Three Explosive Games In One!



Full screen 3-D action as you fight to rescue innocent hostages in a skyscraper wired to explode!



Arcade shooting at its fastest and finest as you eliminate terrorists at Dulles Airport!



Heart-accelerating, driving adventure as you race through New York City to find hidden bombs!

Coming soon for Sony PlayStation,
Sega Saturn™ and Windows 95™ CD ROM.

TECMO'S DECEPTION

You don't play the hero in Tecmo's Deception, the most unusual of the PlayStation's new RPGs. You're not even a nice guy. You're the villain—the antihero—and you want to trap and kill every do-gooder you see.

The game puts you in charge of a castle and entrusts you with keeping it free of treasure hunters and other would-be heroes. If you do a good job, the castle's demonic keeper will help you seek revenge on those who framed you for murdering your father, the King.

The game looks very much like King's Field, except it moves a lot quicker and you don't wield weapons against the castle's invaders. Instead, you take the *Home Alone* approach and set up traps, of which there are more than 40 different kinds.



Some are designed to capture the intruders, while others—like the wall spikes—are designed to just plain hurt. You'll need to inflict some pain, too; many invaders are too quick to be captured unless you sap their spunkiness with a few wall spikes or one-ton weights.

It's best to capture people rather than kill them, since captured invaders yield magic points, and magic points are



Trap-O-Matic

By the time players get to the final level of Tecmo's Deception, they will be able to use more than 40 different traps to capture and maim the castle's unwelcomed guests. New traps are granted each time

players increase their experience level, and later traps can get wild and wacky (wait till you see the vacuum—it really sucks!). Here's a look at a few of the game's contraptions in action.



needed to lay traps. Once you get to the later levels, you can turn your prisoners into monsters that will patrol the castle. The game has six different endings depending on which trespassers you kill or trap on monster slaves.

The other half of

Tecmo's Deception plays like a twisted, old episode of Bob Vila's *This Old House*. You need to add rooms to the castle, and these dens, libraries and other additions are purchased with the money you steal from trespassers. The more rooms you build, the more likely you are to find keys and artifacts. If you find the six Legendary Treasures, you can resurrect the demon—the castle's invaders are really in trouble.

THE ULTIMATE BATTLE IS THE ONE YOU FIGHT ALONE

*The next
experience...
coming in
November*



PERFECT WEAPON



Perfect Weapon™ is a trademark of American Softworks Corporation. ASC Games™ is a trademark of American Softworks Corporation. Developed by Gray Matter. Head Games is used by permission. ©1994 AVG Limited Partnership. ©1998 American Softworks Corporation. PlayStation and the PlayStation logo are trademarks of Sony Computer Entertainment Inc. All rights reserved.

head games.



<http://www.ascgames.com>

SEGA

GAMERS' DAY



Each year, Sega of America holds their own video game exhibition, dubbed the "Sega Gamers' Day."

This "press only" game show gives Sega and their third-party licensees a chance to highlight their latest game wares for the upcoming holiday season. Unlike the E!, where Sega is forced to share the limelight with Sony and Nintendo, "Gamers' Day" allows members of the press (*EGM* included, of course) to view Sega's latest games exclusively. No-shows to this year's event included the long-awaited *Daytona USA: Championship Circuit Edition* for the Saturn. Although the game is still due out in November, Sega decided to show *Daytona* at a later date. What follows over the next few pages is a round-up of what games were hot at Gamers' Day.

SONIC X-TREME

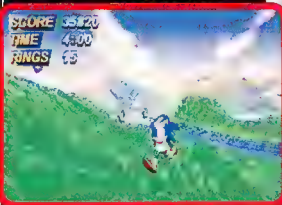

Sega's cute blue mascot finally makes an appearance on the Saturn. *Sonic X-TREME* is a true 3-D game featuring fully polygonal levels that speed along at 60 frames per second. The game includes four zones, with three acts per zone (including the Boss zone) for a total of 12 levels. Look for this one in November.

KRAZY IVAN



One of the hottest games for the PlayStation is making its way over to the Saturn. *Krazy Ivan* is the latest game Sega has acquired from Psygnosis. With complex 3-D environments, futuristic weaponry and over 30 different enemies, *Krazy Ivan* looks to be just as hot on the Saturn as it was on the PlayStation.

BUG TOO!

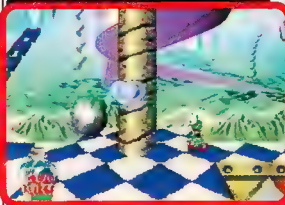

The Bug is back in town, and he's in an all-new sequel. He's brought a few new friends along to the party (namely SuperFly and Maggot Dog). *Bug Too!* has 40 levels and features 3-D rendered enemies, interactive backgrounds and larger levels than its predecessor. Sega is working hard to make the gameplay more balanced and more diverse. One to watch for.

MR. BONES



One of the most fresh and unique games at the show was *Mr. Bones*. Unlike most action games, which follow a single pattern of gameplay, the levels in *Mr. Bones* are individually unique from each other. With fully rendered stages, 60 frames of animation per second and 3-D kinematics interpolated in realtime, *Mr. Bones* is one of the more sophisticated Saturn games.

VIRTUAL ON



One of Sega's most intriguing Model 2 arcade games is Saturn-bound. *Virtual On* is a futuristic fighting game set in huge 3-D environments and uses large armored mechanized robots. *VO* is the latest Saturn creation from Sega's AM3 division (the team who created *Sega Rally Championship*). Exclusive to the Saturn version are a Two-player Split Screen Mode and multiple camera views.

**YOU'LL NEED TOUGH STUDS
AND BIG BOLTS...**



**HARDCORE
4X4**

**... 'cause this ain't no sunday drive.
November '96**



<http://www.ascgames.com>

© 1996 ASC Games, Inc. All rights reserved. PlayStation and the PlayStation logo are trademarks of Sony Computer Entertainment Inc. Sega Saturn is a registered trademark of Sega. TNN Motor Sports is a trademark of Turner Broadcasting System, Inc.

X-WOMEN

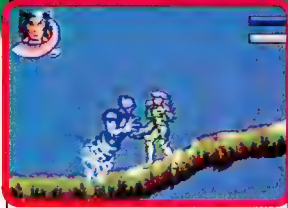

Marvel Comics' X-Women now have a game of their own. Due out early next year, X-Women is a side-scrolling action/fighting game in the tradition of Final Fight and Streets of Rage. In this new Genesis game, players can combine run-and-jump gameplay in the style of Rolling Thunder with the special moves of a fighting game like Street Fighter.

VECTORMAN 2

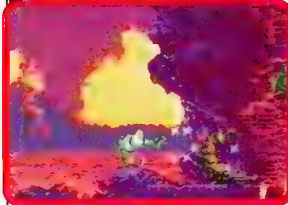

VectorMan's back in a bigger and better sequel. Due to the Earth's toxic environment, VectorMan has again been deployed to destroy mutant insects. VectorMan can now morph into different shapes and forms to better navigate each stage. The morph options include: rollerblade, firefly, tank, tick, rhino and scorpion.

WORLD SERIES BASEBALL 2



The follow-up to Sega's award-winning baseball game is nearing completion. With better 3-D scrolling, a quicker-reacting announcer, fine-tuned gameplay and as much as 28 MLB teams, WSB 2 captured plenty of attention at Gamers' Day. This is Sega's premier sports title and the baseball game to watch.

SCUD



SCUD is an action game based on a comic book that goes by the same name. The game has a unique combination of side-scrolling action and Doom-style 3-D engines. All the characters in SCUD are rendered 3-D models. Top actors provided the voices for the game, and Hollywood producer Oliver Stone has optioned feature film rights.

MASS DESTRUCTION



BMG Interactive's first title, Mass Destruction, is a 3-D tank game incorporating "Sprolygon Technology" to seamlessly integrate 3-D and 2-D objects on screen. Players partake in urban demolition and will get the opportunity to wreak total havoc on 24 target-rich battlefields. This game is one to look out for.

SWAGMAN

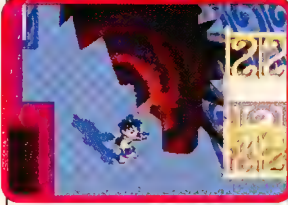

The action in Swagman takes place in over 17 different locations viewed through a forced, overhead 3-D perspective. Swagman pushes the Saturn to the limit with cool light-sourcing and atmospheric effects. Designed by Core Design Inc. (the same people responsible for Tomb Raider), Swagman is definitely one of a kind.

MECHWARRIOR 2

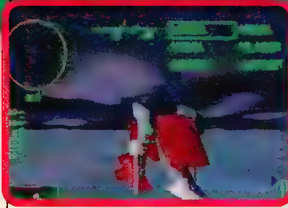

MechWarrior 2 for the Saturn will plunge players into the cockpit of one of more than a dozen "BattleMechs" equipped with lasers, rockets and other futuristic armaments. Loosely based on the PC game, MW2 was designed from the ground up for the Saturn. Players can choose from 32 different missions and can also activate new power-ups not available in the PC games. This one looks hot.

HERC'S ADVENTURE

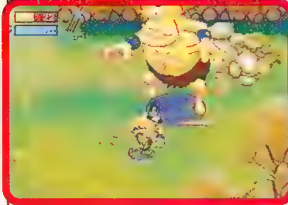

Greek mythology is turned into a virtual toga party starring Hercules and his buddies in LucasArts' light-hearted two-player action-adventure game Herc's Adventure. Herc's Adventure features over 40 unique worlds, three different main heroes (Hercules, Atlanta and Jason) and either a One-player Single Screen or a Two-player Split Screen.

TEMPEST 2000



One of the best games for the Atari Jaguar is finally making its way over to the Saturn. A classic remake of a classic game, Tempest 2000 was one of the stars of Sega's show. Nostalgic fans of the Jag game need not worry, as Interplay has faithfully reproduced all the psychedelic levels, fast-paced action and awesome techno soundtrack that made the game a classic.

PTO II



Fans of war and strategy games will have something to cheer about this holiday season. Koei showed off the Saturn version of PTO II (Pacific Theater of Operations II). Players can relive the 1941 War in the Pacific. Play one of three major campaigns or seven short scenarios. New cinematic sequences have been added to enhance gameplay.

HEXEN



The immersive PC game explodes onto the Saturn this fall. Offering a first-person viewpoint, 3-D graphics and an eerie atmosphere, Hexen is one of the better "Doom clones" on the market. (Fortunately, id Software, the creators of Doom, also produced this game.) Hexen has smooth 3-D scrolling and reactive gameplay.

DOOM



The game that started the first-person-shooting craze is finally Saturn-bound. With both Doom I and II on one CD, this sure-fire crowd pleaser is guaranteed to make a big splash this holiday season.

ID4



This summer's must-see, smash-hit motion picture is turning into a game for the Sega Saturn. Even though ID4 (the game, not the movie) is far from complete, the 3-D texture-mapped polygon flying sequences looked mighty impressive. Everything from the alien fighter crafts to the mother-ship will be seen in this action-packed title.

LUNAR

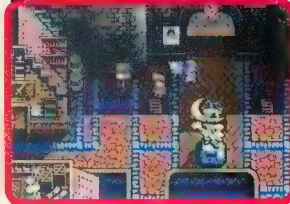

Working Designs showed an early works-in-progress version of Lunar for the Saturn. Based on the Sega CD game with the same name, Lunar features more music, more towns and more animation sequences than the 16-Bit classic. Due out late next year, Lunar has the potential to be the best RPG for the Saturn yet.

STREET RACER



Ubi Soft's Super Mario Kart-ish driving game will be unleashed on the Saturn this October. Featuring stunning 3-D graphics, 60 frames of animation, eight different races, 24 separate tracks, multiple camera angles and more, Street Racer was one of the best games at the show.

WATERWORLD

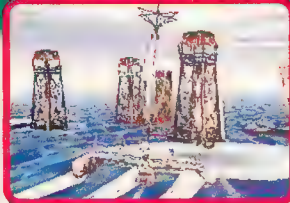

After spending almost two years in development, Waterworld for the Saturn is nearing completion. Using a heterogeneous rendering engine, Ocean's in-house development team has created a stunning 3-D environment. Players sail aboard a trimaran in an attempt to rescue Atollers from the Deacon's bandits. Waterworld has some of the best graphics ever seen on the Saturn.

MEGA MAN 8

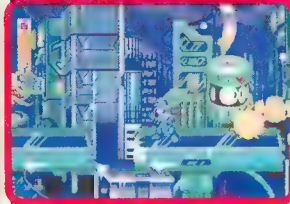

Capcom's blue titanium hero is back in an all-new adventure. Mega Man 8 introduces a whole new set of Bosses, new backgrounds and even more new weapons to the Mega Man universe. Capcom was showing an early version of MMB at Gamers' Day, but, even so, it was more than a match for the PlayStation game.

BLACK DAWN

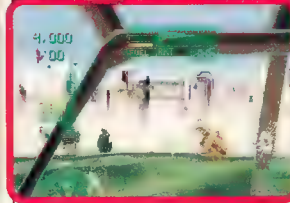

Black Dawn by Virgin Interactive Entertainment features a frame rate of 30 fps, a Two-player Deathmatch Mode, huge explosions, interactive background music and a variety of weapons. Black Dawn is a dream come true for chopper-sim lovers.



3-D Fighting Hits New Heights in Realism

VIRTUA FIGHTER 3

Sega is finally getting ready to unleash its ultimate 3-D fighter on the gaming world. Virtua Fighter 3 is the fifth game in the Virtua Fighter series, which includes the hit games Virtua Fighter, Virtua Fighter Remix, Virtua Fighter 2 and the ever-lovin' Virtua Fighter Kids. Long-time fans of the VF series will be glad to learn that all of their favorite characters have returned, and two brand-new characters have joined the battle as well.

Aoi Umenokouji is the first of the two new combatants. She uses the grace and elegance of traditional

Japanese dance in her fighting technique. Even though she's the newest Virtua female, Aoi looks like she'll definitely be able to hold her own against all the old-school fighters.



sumo wrestling? Nice job! Takaarashi wears conventional sumo garb, which isn't much, so get ready to check out a lot of virtua flesh (maybe too much).

The rest of the crew retains most of their original style, except now they look much better—thanks to the new Model 3 technology. The animation is as smooth as Aoi's silk top, and the characters have now obtained a point of creepy "almost realism"



body. Never before have the forces of inertia and gravity been conveyed so convincingly in a video game.

Another feature of the clothing is that each article moves as though it is actually made from its respective material. That means that Jacky's leather jacket moves with the heaviness of leather, and Aoi's silk outfit moves in a sort of gentle flow. This attention to detail makes her attacks seem especially delicate, even when she's pounding her opponents into the ground.

The other fresh face on the VF scene is Takaarashi, the humongous sumo wrestler. Give yourself a hearty pat on the back if you can guess his fighting style. Did you

unmatched in any other game. VF3 will, without a doubt, set a new visual standard for 3-D fighting games—and all arcade games in general.

For instance, clothing now moves independently of the body. When Pai does a Spin Kick then comes to a stop, her braids and skirt continue moving for a moment before they settle around her





at the way the character's head followed jumping opponents. Now they'll once again stare in awe as the camera zooms in on someone's face after a match and shows every facial expression. I'm not afraid to admit that when I

watch Pai slowly shift her eyes toward me and subtly smirk after she downs my spine. Yes, it's *that* eerie.

What fighting game would be complete without a final Boss? Dural returns once again to pummel anyone foolish enough to challenge her. Like everyone else, she too has benefitted from a Model 3 upgrade. In VF3, she does her best impression of the T-1000 from *Terminator 2*. She morphs from a pool of liquid metal into a humanoid form as light from the

stage reflects off of her super-shiny body.

The backgrounds also look rather nice. Characters now have ultrarealistic-looking shadows that vary depending on the stage's lighting. There will also be some interaction with the background. For instance, some special moves can be performed off walls. Even minor details—such as sand and water being kicked up as you walk through it—are commonplace in VF3. If you thought VF2's backgrounds were realistic, think again: VF3's highly detailed locales will make

you rethink your definition of "real."

Usually, when a game looks as good as this one, actual gameplay is forgotten. This is not the case with VF3. The game will play just as well—if not better than—VF2. As Virtua Fighter veterans will tell you, that's pretty darn good. We could talk for days about how great VF3 is, but these pictures certainly speak louder than words. All you arcade fighting fans out there should start saving your quarters now; you will need a ton of them when Virtua Fighter 3 hits the arcades. ■

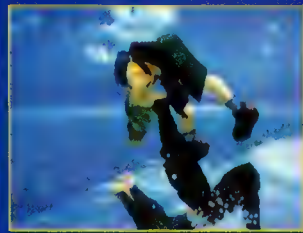

This October Tecmo® will offer you an Invitation to Darkness exclusively for the Sony PlayStation.

Should you accept Tecmo's invitation you should be warned!

You must decide who lives and who dies. As in life, Tecmo's Deception will hold you responsible for your actions. Everything you do, everyplace you go, everyone you meet has a reason. Are you seeking revenge, resurrection or redemption? It's your decision.

If you are strong enough and smart enough to accept the Invitation to Darkness you will play Tecmo's Deception.

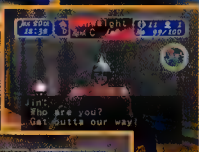

TECMO'S DECEPTION™ RESERVATION/DEPOSIT FORM:

Dear Retailer:

The customer whose name and address is listed below wishes to place a non-refundable deposit on Tecmo Super Bowl. Please contact your local game distributor and/or your central buying office for specific instructions.

Name _____ Amount of Deposit \$ _____
Address _____ Store Stamp or Receipt
City _____ State _____ Zip _____
Phone Number _____

Reserve me _____ copy(s) for the Sony PlayStation™

TECMO'S DECEPTION™

Invitation to Darkness

COMING IN OCTOBER

\$59.99
OR LESS



TECMO®

Visit Tecmo Interactive at: <http://www.tecmo.co.jp>

N64



Turok The Dinosaur Hunter

Jurassic Park Is Child's Play Compared to Turok

At first, EGM was unsure what to think of an Indian somehow transported into a prehistoric era—a land where dinosaurs and apes have bionic arms and hi-tech weaponry. To us, this whole story sounded strange. Then EGM realized that Acclaim was talking about Turok: Dinosaur Hunter and everything became clear.

Originating from the pages of a comic, Turok is trying to make a new kind of adventure—one in a 64-bit monster rather than a hand-drawn half-toned world. Turok is pleased and has every right to be. The game has a huge array of weapons to find and choose from and the graphics and character animations are enough to make a gamer's jaw drop



off their face. Need we say, "Ouch?"

Since the comic world, Turok has had his ups and downs (going from comic company to comic company, being released then cancelled). He's now found a safe home with Acclaim. Who knows what they have planned for Turok besides a game? What we do know for sure is that the N64 first-person action title is something special.

EGM was able to see an



early version of Turok recently when Acclaim graced us with their presence, and what we saw made us anxious about what later versions will bring—and the final production copy! But that's the future and what we saw was only three playable levels of the game that had a similar motif and dozens of screen shots of later ones with bigger enemies.

In the style of Doom, Turok offers something no other home system can do: the sharpest graphics, huge

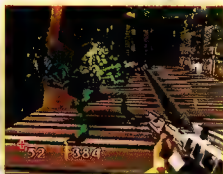

levels and a cool story. All of this on a cartridge—that's the difference. No load time! The enemies—be they man or beast—have been rotoscoped with Acclaim's motion-capture technology to ensure high-quality, realistic movement.

RELEASE DATE	DIFFICULTY	
November	Moderate	
PUBLISHER	% DONE	
Acclaim	50%	
THEME	PLAYERS	SIZE
Action	1	64-Meg

WEAPONS

Turok doesn't seem to be in his own element when he's walking around in dino land, but since he's not really from that era, neither are all of his weapons. As you can see, Turok uses anything from a standard hunting knife all the way up to the nuclear fusion gun. If you think they look cool, wait until you use them! Enjoy.

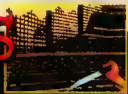

The Hunting Knife - Like Rambo, Turok will use this against his enemies. Unlike Rambo, this won't be Turok's first blood.

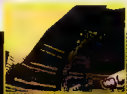

TEK Bow - Silent and deadly, this bow uses regular arrows and TEK arrows which are more powerful than the standard arrows.



Semi-Automatic Pistol - We'll call it the pea shooter. It's definitely a last resort. This one does next to no damage.

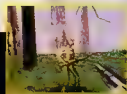

Automatic Shotgun - What action game is complete without an automatic shotgun. On top of shells, you can fire explosive rounds, too.



Assault Rifle - Three words: three round bursts. This one is great for quick assaults—hence the name. Similar to an old style machine gun.



Check the pulse of this enemy with your pulse rifle.



With these real enemies comes a need for some real weapons. Turok can deliver with no problem in this department. Like many Doom-type games, the dino-huntin' Indian starts with only his axe. After enemies are killed, more weapons can be obtained. Turok's arsenal can be found in the weapons sidebar below—aptly named, eh?

Early versions of Turok showed heavy fog effects to



Spear versus chaingun...I wonder who will win? Hmmm...



cover up some of the problems with the environments and loading of the texture maps. EGM is glad to say that we saw no glaring use of fog in this updated version, even though there was fog used in the Jungle Level (and probably in later levels at press time unseen). With more tweaking and optimization, the final Turok could very well be the most impressive first-person action game to date.



"Turok could very well be the most impressive first-person action game to date."

So far it seems like Turok sets out from the past (like dinos and giant ferns and such) eventually making his way to the future world where the alien-bionic dinos originate from. Each level has its own style like the Jungle Level shown. Unlike games such as Duke Nukem, Turok goes for a more gritty, realistic look. The characters don't necessarily look like hand-drawn, modeled characters. Instead they look and move like real people and or animals.

Now that EGM knows what Turok is all about, the idea of

an Indian in a dino-laden world blowing them to pieces is okay. After all, who better to do the job than the adventurous hero, Turok—using his nuclear fusion cannon EGM likes to call "Big Poppa." ■



Just how much blood does a alien hold? Keep shooting to find out. After all, when you have a mini-gun, what are a few more rounds?

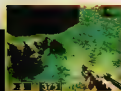
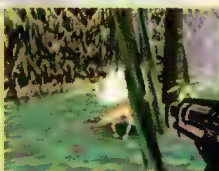

Pulse Rifle - This rifle is used to check the pulse of your enemies after you shoot them. Actually, it fires concentrated energy particles.

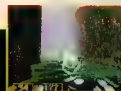

Alien Infantry Weapon - The alien dino's standard issue. Didn't I just see something like this in *Eraser*? What a cool weapon!



Mini-Gun - For as big and powerful as this weapon is, something about the name just doesn't fit. This one has great animation.

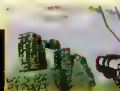

Grenade Launcher - This one launches grenades. Go figure. Really though, this one packs a wallop. Don't shoot it close to walls.



Quad Missile Launcher - A very powerful weapon. Four missiles at once which of course causes some pain to the enemy.



Shockwave Accelerator - A highly lethal beam follows the ground and roasts anything that moves. Very powerful.

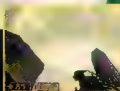

Fusion Cannon - The big boy of all the weapons in Turok. It has A-bombs instead of shells. It looks similar to the shockwave gun.

FIGHT LIKE A MONSTER



BRING A MOP...
THIS IS GONNA GET MESSY.

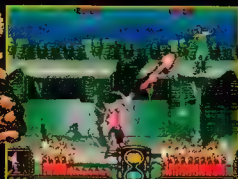

FREAKISH CARNAGE IN SPRAWLING
MULTI-PLANE ARENAS!



MUTILATING SUPER-MOVES
THAT'LL MAKE YOUR HEAD SPIN!

BATTLE MONSTERS FOR SATURN™

There's a rumble in hell...and you're invited. Twelve psychotic monsters fight fist-and-fang in the darkest, goriest head-to-head combat ever! In bone-chilling interactive, multi-levelled environments, the beasts of the undead unleash clawfuls of sickening supermoves in a bid to be crowned King of Darkness! Overflowing with blood, guts, drool and slime, Battle Monsters is mangling multi-hit, mid-air fighting with super-fast scaling, chopping, stabbing, gouging, morphing and dying. Feeling lucky, freak?



Battle Monsters © 1998 naxat CO., LTD. All Rights Reserved. Sega and Sega Saturn are trademarks of SEGA ENTERPRISES, LTD. All rights reserved. Acclaim is a division and registered trademark of Acclaim Entertainment, Inc. © 1998 Acclaim Entertainment, Inc. All rights reserved.

OR A

naxat soft



MONSTERS KNOW
NO MERCY!



THE MORE YOU WIN
THE STRONGER, FASTER AND
MEANER YOU GET!



3-D POLYGONAL SLUG-FEST WITH
BUCKETS OF GORE!

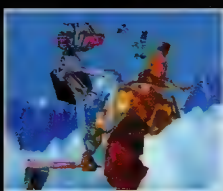

GOT SOMETHING STUCK
IN YOUR THROAT?

KILLING ZONE

FOR PLAYSTATION™

Go head-to-ugly-head in a grisly, blood-drenched 3-D slugfest! Seven freakish monsters, slathered in gore, go all out in Killing Zone's eyepopping 3-D arenas! The more they mutate, the more mindblowing the super-moves they can pull off! Set your mongrels free in an automated Death Tournament and watch as they evolve into purebred killing machines! From the gargantuan Gorgon to the psycho Skeleton one thing's for sure...this ain't no beauty contest... this is a monster jihad!

DIE LIKE FREAK

Acclaim
entertainment inc.

www.acclaim.com

Killing Zone © 1996 Next CO., LTD. All Rights Reserved. PlayStation and the "PS" logo are trademarks of Sony Computer Entertainment, Inc. Acclaim is a division and registered trademark of Acclaim Entertainment, Inc. © 1996 Acclaim Entertainment, Inc. All rights reserved.



SATURN



FIGHTING VIPEERS

The Worthy Follow-up To VF2

Sega's Model 2 board wowed many arcade goers when Virtua Fighter 2 debuted. New standards in 3-D animations were set, fluidity took on a new meaning and polygon counts hit new heights. Since VF2 became an overnight success, a follow-up would be inevitable. Instead of Virtua Fighter 3, however, the new

game was to become Fighting Vipers, as VF3 was to be reserved for greener pastures in the form of an even more powerful Model 3 board. Fighting Vipers never received the popularity that VF2 got in the arcades. (Sega proudly stated that over 2500 VF2 stand-up units were sold to arcades in the initial 18 months but then would not comment on how many

Behind The SCREENS

If you finish off your opponent with a super armor-breaking move, you will smash him through the barrier or wall. It doesn't mean anything; it's all for show.



You can play as the Boss if you want to, though he seems to have changed his name from B.J.M. to a more descriptive Mahler.

Fighting Vipers machines were sold during its initial period. Pretty convenient, isn't it? Since the Saturn is clearly capable of running these types of games, however, why not bring FV home to help show off the Saturn's power? Perhaps the home version might reach out to more people and make more money than the arcade version did.

Fighting Vipers has the look

"You won't find normal martial artists in Fighting Vipers..."

and feel of Virtua Fighter 2, and yet has its own distinct appeal. You won't find normal martial artists in Fighting Vipers, only a strange assortment of civilians. What constitutes a strange assortment?

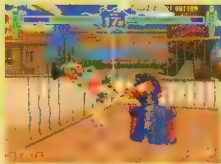

A flash always precedes a super powered armor-breaking move.



Try not to get too hung up on the barbed wire walls.

People like Raxel, an '80s rock star wanna-be (note, these are our words, not Sega's!); Picky, a streetwise skateboarding kid; Grace, a tough-as-nails Amazon-sized in-line skater; or Candy, a sensuously dressed cat fighter. Even the Boss is a bit peculiar, as he's

RELEASE DATE	DIFFICULTY	
November	Moderate	
PUBLISHER	% DONE	
Sega	55%	
THEME	PLAYERS	SIZE
Fighting 1	or 2CD-ROM	



The Winger reject Raxxl ends the game with a picture-perfect move, crushing his opponent's torso with his Flying-V Guitar.

just a large muscular man dressed up like G.I. Joe's evil nemesis, Serpentor.

All in all, nine fighters are available to play, including the Boss Mahler. They are all competing in a tournament whose name may cause a few males to cringe—Nutcrack. The object of Nutcrack is to smash through your enemies' armor in order to destroy the person underneath. Not much of a

story line here, the most interesting thing being the name of the tournament.

Donning armor is perhaps the freshest feature Fighting Vipers has to offer. Each separate piece of armor protects a specific area of a fighter's body. If a certain armored piece is hit continuously by the opponent, it will be broken off. If that happens, the respective body part

"They are all competing in a tournament whose name may cause a few males to cringe—Nutcrack."



Hmm...panties, garters and lace. Can anyone guess which demographic group Fighting Vipers is supposed to appeal to?



that was formerly protected will be exposed. Any further attack on the unprotected part will cause greater damage than normal. Each character has, in addition to his or her normal repertoire of attacks, a couple of super armor-breaking attacks. These are nothing spectacular, but they will do more damage to armor than normal attacks.

Another noticeable feature of Fighting Vipers is the lack of a ring-out penalty. All fighting areas are completely enclosed on all four sides. It's almost like the cage match found so often in professional wrestling. These walls can be fences or barbed wire, which

has an uncanny effect of keeping most intelligent players farther away from the edges and closer to the center of the squared circle. Throwing opponents in a fighting game becomes many times more interesting when minor physical barriers like sharp barbed wire fences are surrounding you.

Fighting Vipers is a great alternative to Virtua Fighter 2, but it did not get the exposure it may have deserved. The question of the hour is: How will Sega market a game that many people passed up in the arcades or have missed all together? ■

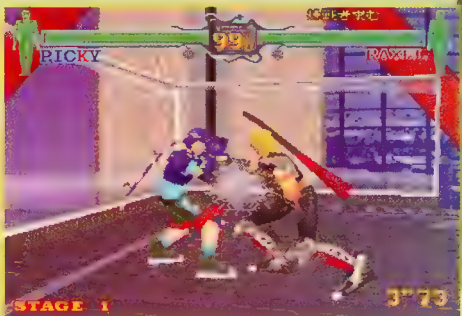

Gamer's Edge

Fighting Vipers takes a different approach from most 3-D fighting games. Instead of open arenas like in Virtua Fighter, all battles take place in contained

areas, something that was first introduced in the 2-D fighter World Heroes. This not only prevents ring-outs, but adds a new dimension in fighting techniques. You can juggle opponents against the wall and get in extra hits. Certain arenas are surrounded by barbed wire, which will obviously damage you if they're touched. Try throwing an enemy into the wire for some old-fashioned fun.

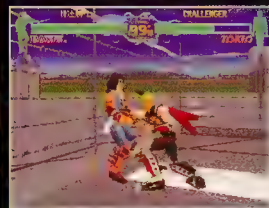

SATURN



AREA 51

Whup E.T.'s Butt

The Air Force has a serious PR problem with its Area 51 air base. UFO fanatics have for years claimed that the fabled facility is home to downed flying saucers, alien corpses, biological experiments and other E.T.-related hanky-panky.

The Air Force isn't doing much to ease suspicion, either. It certainly hasn't opened the Nevada-based air facility to tourists (the Air Force isn't too keen on flash photography). In fact, the U.S. government denies the base even exists.

But gamers know otherwise. They've already blasted their way through

the base—or, at least, a video-game version of it—courtesy of the arcade game Area 51, which is now coming to the Saturn. This shooter sends players through six areas of the top-secret facility, each one supposedly modeled after portions of the real base (see sidebar). The game's areas are infested with hideous half-alien, half-human creatures that must be blasted from the face of the Earth. The game is light-gun compatible, or players can use the joypad or mouse (which makes aiming easy).

Area 51's plot spans two danger-filled days at the base. It seems that the Air Force's constant tinkering with alien technology has landed Area 51—and, perhaps, the rest of the world—in a mess. Now innumerable mutating alien creatures have taken over the facility.

Fortunately, the military isn't unprepared for such mishaps. The president has called in the Strategic Tactical Advanced

Alien Response (STAAR)

Team to deal with the mob of mutants. This team is specially trained to clean up after the misguided experiments of military eggheads—and you're the team's chief action hero.

You, therefore, spend the rest of the game trying to win Area 51 back from the mutants—namely by blowing

the ugly heads off every alien you see. You start the game with your trusty pistol, but as you progress through the base, you'll come across grenades and power-ups that give your gun a brief boost of automatic fire or turn it into a shotgun. Your adventure through the base isn't always on foot. Sometimes you'll hop



KABOOM! The game is full of debris-chucking explosions.



From aliens to mutants, there's a whole lotta' ugly in Area 51.



GAMER'S EDGE

The easiest way to rack up points in Area 51 is by streaking. No, not the type of streaking college kids did back in the hippy days. The Area 51-style of streaking demands

dead-on aiming of your light-gun (although you could still play the game in the nude if you like). If you hit enough targets—whether they are aliens, windows or barrels—without missing, you begin a streak and stay on it until you miss. Once you get on a streak, your score begins to double, then triple for every target you blow away. Streaks are easier to keep going with a powered-up gun, such as the shotgun, since it's less prone to miss targets.





Like something out of a twisted version of Donkey Kong, some mutant aliens toes barrels at you. Chuck a grenade at them in return.

aboard vehicles—such as humvees, helicopters and, oddly enough, forklifts—or take to the air in a helicopter.

But you won't be running and riding through the base on your own; other members of the STAAAR team fight

alongside your character (not to mention two players can shoot alongside each other). Just watch your aim. As in other shooting games, you lose health if you cap friendly targets.

Area 51 is at its heart a

GAMER'S EDGE

Area 51's developers realized that it's no fun being human all the time. That's why the game contains an Easter egg that lets you play as a "good" alien rather than a STAAAR Team member. Accessing this Play Mode—called the Kronn Hunter Mode—is simple. Shoot the first three STAAAR Team members who appear in the first level without blowing away anything else.

You'll take a lot of damage while you wait for the humans, but that can't be helped. If you nail all three of your uniformed teammates, you'll become a "bad" alien hunter. You'll spend the rest of the game blowing away the "bad" aliens, which you see through your infrared perspective.



"The game uses a mix of visual tricks."

Behind The SCREENS

The Area 51 game may show players more than the Air Force would like them to see—thanks to some old-fashioned Cold War espionage.

It seems that back in the Cold War days, Russia was just as curious to see what the Air Force was hiding at Area 51 as everyone else. So they launched a spy satellite to peer at the air base from orbit.

Unfortunately for the Russians, the Air Force quickly detected the satellite as it streaked above the base. Since satellites follow predictable paths through the sky, it was no problem for the air force to shut down Area 51's operations during the hours the base was visible to Russia's spying eyes. All the Russians saw, therefore, was an ordinary-looking air base, a few Air Force planes and absolutely no UFOs or aliens.

But the Russians still snapped plenty of pictures of the base, and they leaked these photos to the U.S. press (*Time* Magazine even ran them). Eventually the photos were nabbed by Mesa Logic, the team of 3-D artists who designed the rendered environments for the arcade version of Area 51.

"The people at Mesa Logic picked up the photos of the layout of Area 51, so what you see is more or less an accurate representation of the base," said Howard Lehr, Williams' associate producer for the home versions of Area 51. "They wanted to make it as much like the real base as possible."

Of course, Lehr said, the Russian photos don't show what goes on inside the facility, and the base's secrets are anybody's guess. The game Area 51, Lehr said, may be as close as gamers get to touring the infamous facility.

"Obviously we couldn't get a guided tour through the alien nest," he said. "We're not going to brag and say we've been in there. Nonetheless, we've done the best we could to show you what the base looks like."

FMV game. Its 3-D, prerendered environments spool off the CD as players progress through the base. Still, the game uses a mix of visual tricks. Actors were digitized to portray fellow members of the STAAAR team, and stop-motion animation was used to create the game's population of mutants.

Williams claims the Saturn version of Area 51 will be identical to the arcade machine. That means it will have all the secrets that made the game stand out from other shooting titles. Area 51 contains a total of 14 secret areas, which can be accessed by shooting certain targets like windows or barrels. It also features the infamous Alien Hunter Mode, which turns the tables on the STAAAR team (see sidebar).

Yet whether the game offers an accurate look at the real Area 51 air base is a different story. One thing's for sure: The Air Force will never tell. ■

RELEASE DATE	DIFFICULTY	
September	Moderate	
PUBLISHER	% DONE	
Williams	70%	
THEME	PLAYERS	SIZE
Shooting 1 or 2 CD-ROM		

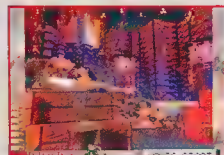

Area 51 has a Practice Mode for those who can't shoot straight.



Your STAAAR teammates are always eager to give you a lift through the air base. Just be careful you don't accidentally blow them away.

SATURN

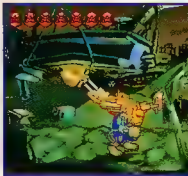
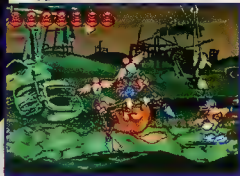

Three Dirty DWARVES

They're Makeshift Sportsmen And, Man, Do They Stink

Sometimes RPG board games can provide a type of escape from reality. When done the right way, this can be fun. When done in excess, one might consider it to be a delusional disorder. Nonetheless, Sega Soft's premier title, *Three Dirty Dwarves*, revolves around three characters from an RPG board game that four kids play to escape their troubled existence.

When four test tube babies grow up to be geniuses instead of perfect warriors, the evil General Briggs decides to use them to

manufacture hi-tech weaponry. The only thing that can save the kids is their favorite RPG and the three heroic dwarves that dwell in the make-believe land.

TDD plays like a *Final Fight* game with cartoon characters instead of the buff martial artists. The dwarves and enemies are highly animated, looking like something out of *MTV Oddities*. Since the dwarves are warped out of their own make-believe world, they'll of course have to adapt to the new earthly world.

Luckily, the dwarves have fallen into a sporting goods

store, and they use items from the present day as tools of war—items like bats, bowling balls and shotguns. Since the three dirty ones aren't accustomed to our day, they use football equipment and other odds and ends for armor.

With the dwarves, the enemies from the RPG world come through the portal the children open. That's who they destroy, eventually making their way to the mastermind of the game, General Briggs.

Each dwarf has his own method of attack. Taconic has a pin used like a club for

close combat. The bowling ball is used to battle multiple enemies, preferably at greater distances. Next, there's Greg—he uses a bat for close combat. He also has a sack full of baseballs which he tosses up

Gamer's EDGE

Those Wacky Morph-Dwarves

Enemies tend to gang up on the poor semi-defenseless dwarves...well, they're not defenseless at all but they do need their special attacks many times in the various levels of the game. As mentioned, the dwarves can combine to become the morph-dwarf (as seen in the picture to the right). These morphing techniques require four skulls.

Depending on what dwarf you are controlling at the time, the type of morph-dwarf you become changes. Here's a breakdown of the different morph-dwarves: **Bat-toting Greg** morph-dwarf hocks big phlegm balls at enemies. **Ik.** **Bowlin' Taconic** morph transforms the dwarves into another enemy-killing spitter. **Shotgun-blasting Corthag** morph blasts enemies with a barrage of bullets. Yes!



The junkyard seems like just a bunch of spare parts. When you combine that with the magic of TDD, strange enemies appear.

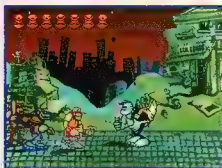

The dwarves do like cocktails but not the explosive kind.

DRIVING.
SHOOTING.
SLAMMING.
LOUD MUSIC.

NO, IT'S NOT
THE L.A. FREEWAY.

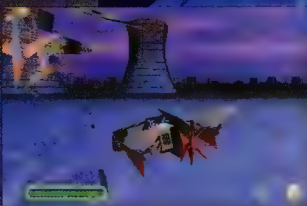

IT'S SLAMSCAPE.

With fast-action gameplay inside an *interactive soundtrack* by *God Lives Underwater* and the *fastest real-time 3D graphics* available, it's like taking the scenic route to hell and back. Battle your own private demons at *lightning speed*. And thrash your head off in *360 degrees* of pure danger.

AVAILABLE ON: PC CD-ROM &
THE PLAYSTATION™ GAME CONSOLE

Featuring the music of GOD LIVES UNDERWATER as seen on MTV.

SLAMSCAPE™

AN  VIACOM PRODUCTION
newmedia

www.viacomnewmedia.com

CALL 800-469-2539 TO ORDER.

DEVELOPED BY
VIACOM
newmedia



Behind The SCREENS

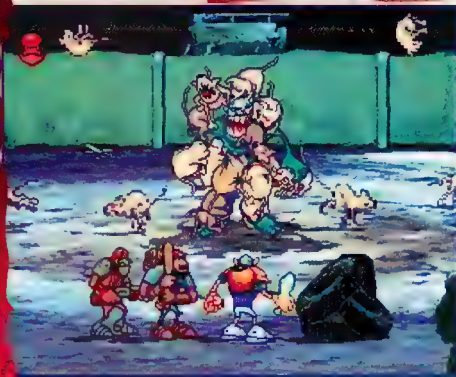

Even dirty dwarves need lovin' but not from the enemy!

gives gamers an edge when they're in a bind. Check the Gamer's Edge for morph info.

Besides the regular attacks, the dwarves have other attacks that they can use like the full-auto shotgun that Corthag can use. These require skulls—each of the previously mentioned attacks uses two skulls whereas the morph attack uses four. Gamer's can pick skulls up in the levels. They're found in boxes and from fallen enemies. It pays to save skulls, but it also pays to use them since dying isn't a good thing in an action game like *Three Dirty Dwarves*. Check out the Review Crew in this issue to see how the game scored. Maybe delusional disorders aren't so bad after all. ■

As mentioned in the Next Wave text, *Three Dirty Dwarves* features some killer cartoon cinemas and awesome character animation within the game. Like Sega Soft says, the look of the 'toons looks like something out of *MTV Oddities*. Actually, the style is more like *Liquid Television* on MTV. In the intro sequence when one of the dwarves pulls the stomach through the mouth of one of the enemies, memories of *Liquid TV* pop into my head.

Not only did Sega Soft come up with the sketches of the characters (as shown—the Boss Pit Bully), they also did some clay models. Since there are so many characters in TDD, the real treat is when you see them move, speak and destroy!

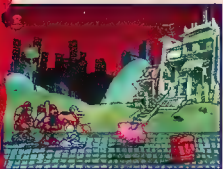

"...four test tube babies grow up to be geniuses instead of perfect warriors."

and hits toward his enemies. This is especially effective when gamers are confronted by a powerful enemy or a row of enemies. Finally there's the third dwarf, Corthag. His weapon isn't as "hands-on" as the others. His shotgun packs a wallop, but the intervals

between shots is long so it pays to use the butt of the gun to knock the thugs to the ground. Although there are only three dwarves there is a fourth pseudo-dwarf. By combining the powers and features of all three dwarves, players can have a morph-dwarf. This feature

RELEASE DATE	DIFFICULTY
October	Hard
PUBLISHER	% DONE
Sega Soft	75%
THEME	PLAYERS
Action 1 or 2 CD-Rom	SIZE



Is that Chrissy Albertson? Actually it's the Duct Tape Lady! Look out or she'll wrap you up. Man oh man, that does hurt the arm hah!



The future
of racing...
fully-leaded,
3-D autocide!
Live fast. Die fast.
12 twisting tracks
of high-velocity,
demolition derby
where you shoot first
and overtake later. Pick up lasers,
mines, smart bombs and heatseeking
missiles...then put the pedal to the metal and
waste the competition. It's kill or be roadkill!

IMPACT RACING™



**ROAD HUGS FIGHT
TO AN ICY DEATH!**

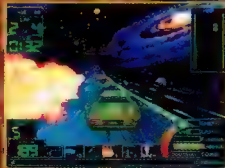

**CRASH AND BURN ON
THE INTERSTELLAR HIGHWAY!**



**IN-CAR-CAM FOR AN
IN-YOUR-FACE DEATH RACE!**

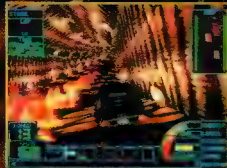

**USE EXPLODING FIREWALLS
TO CLEAN UP YOUR
REAR-VIEW MIRROR!**

PLAYSTATION SEGA SATURN



**FUN
COM**

JVC

Impact Racing™ is a trademark of Acclaim Entertainment, Inc. Impact Racing published under license from Acclaim Entertainment, Inc. JVC Musical Industries, Inc. PlayStation and the PS™ logo are trademarks of Sony Computer Entertainment Inc. Sega and Sega Saturn are trademarks of SEGA ENTERPRISES, LTD. All rights reserved. © 1998 Acclaim Entertainment, Inc. Screen shots shown are taken from the PlayStation version of the videogame.

Acclaim
Entertainment Inc.
www.acclaim.com

SATURN

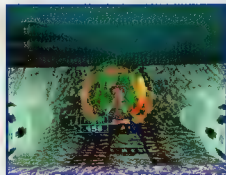
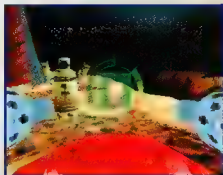
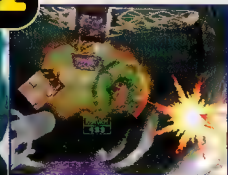
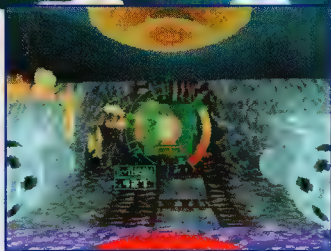
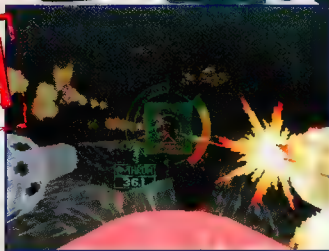

MACHINEHEAD

Busy Cleansing The Earth

The year is 2005, and as a result of a new breed of supervirus, mankind is facing destruction.

The cause of these problems was traced to a control-freak scientist who—while playing around with home-brewed DNA—created a life-threatening supervirus that has infected Earth.

After failing to create an antidote, Dr. Stride finds herself strapped to a flying bomb by her demented assistant, Orville. She must now cleanse what is left of the Earth from all those infected by the virus. To complete her mission, she

must use the machine's deadly manifest of cargo to eliminate the hundreds of zombies and eventually work her way up to Orville in order to blast him before he detonates the vehicle out from under her.

Machinehead features over 15 missions that allow the player to traverse through the fully rendered 3-D landscapes and attempt to eliminate the 100+ enemies in the stages. Vehicle armament consists of 10 different deadly weapons to use for offensive as well as defensive purposes. These range from flamethrowers and machine guns to missiles and plasma beams.

Machinehead controls in a matter close to Descend without the 360-degree capabilities. Players have control over the craft's height, speed and angle of attack, as well as the different weapons which are always at their disposal. Players can move forward and attack with blazing speed as well as stop and play the turret role to clear out multiple enemies packed in small areas. The flying bomb you ride tends to be a ground-hovering weapon, but it can be coaxied to raise into the air through carefully blending the use of levitation and thrust capabilities.

The terrain found on the various levels combines large

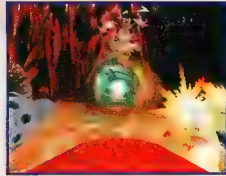

sections of flat plains with a good mix of giant rock formations that push high into the vertical. The flight capabilities of the character's vehicle, however, allow players to explore these high areas that would normally be out of reach. The terrain also has structures that spice up the landscape through the use of game elements such



As in most games, you can collect your winnings after destroying some of the enemies forces. These power-ups are essential to advancing.

"...Machinehead is a step in the right direction..."



Avoid this fire starter altogether to ensure your safety.

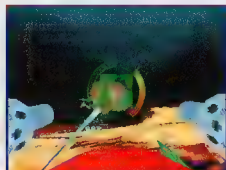

Use your guns and your special weapon simultaneously.

WEAPONS

Helping you in your travels are the various armaments built into your hovering bomb bike. The key to taking out tough enemies is to strike with the right weapon.

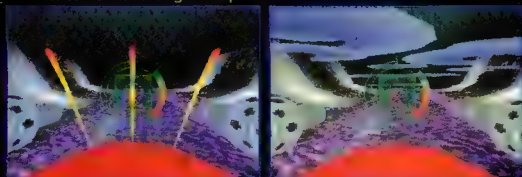

This disrupting weapon fires three blasts from its barrel. Once they land near their target, they cause a storm effect, striking any enemies standing under it. This weapon is a great way to take out those fast-moving, flying enemies that are hard to get a bead on.

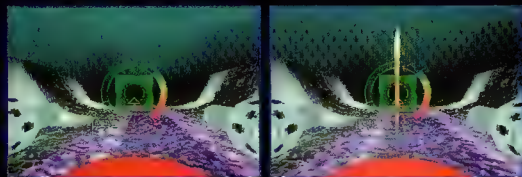

Single weapon blasts such as the grenade launcher can be a valuable asset in the hands of a user with knowledge and the control to place it right where it is needed. Use the ship's angle of attack to guide how far the grenade is launched.

as farms, windmills and abandoned vehicles.

Players will also discover the speed and mobility of which enemies attack while you are searching the countryside. In the beginning levels, fast-moving land spiders rush your character and strike with ferocity. Aerial attacks come from giant bumble bee-looking 'bots that never seem to stand still longer than a couple of seconds before they reposition themselves on your flank for another attack. Considering the attack speed of these two potent enemies, a player's best choice is to stand still and play the turret role in these situations.

Many players will feel Machinehead is a step in the right direction for first-person shooters. Although not the best game in Eidos' end-of-the-year lineup, it is still lots of fun for the select type of player for which it was designed. ■

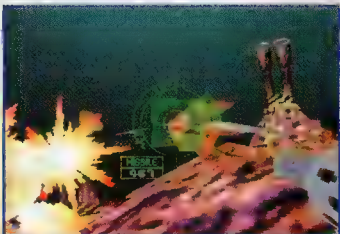

RELEASE DATE	DIFFICULTY	
December	Moderate	
PUBLISHER	% DONE	
Eidos	70%	
THEME	PLAYERS	SIZE
Shooter	1	CD-ROM

CAPCOM ORIGINAL SCREEN SAVER

© 1996 Gaia Associates, Inc. Other registered trademarks are of their respective companies.

Collector's Item!!

For Windows 3.1 and Windows 95
Macintosh Version coming soon!



Available only through the Internet, for a limited time. This is a one-time offer.

Order Now by phone or fax at:

Tel: 1-800-526-3832

Fax: 415-389-8832

Through the Internet at:

<http://www.gaiaweb.com/capcom/>

\$45.00 (Shipping & Handling \$4.50)

Payment by credit card, check, or money order



Exclusive Offer for this Limited Edition

- Active Motion CD Case
See your favorite characters in action
- Original Sound & Character files from the games, as well as new digital portraits
- For the first 1,000 customers a set of three A4 size, full-color posters

Screen Saver Features: * Animation (23 characters) * Wallpaper (all characters) * Alarm Clock * Graphic Viewer * Calendar with scheduling function * For more details check out Gaia's home page and download a free sample.

<http://www.gaiaweb.com/capcom/>



Crystal Rim, Inc.

P.O.Box 64125 San Francisco, CA 94164

Tel: 415-389-8083 Fax: 415-389-8832

Life on the edge

The Saturn version of Robo Pit is a bit harder than the PlayStation version, but it still lets you pull off a trick that's almost guaranteed to (literally) knock out your opponent.

Before you enter a match, choose a pair of arms for your robot that are good for pummeling and knocking around bad guys (the fists and sledgehammers work nice). Once combat begins, lure the enemy robot near the edge of the arena, then maneuver your 'bot so the bad guy is between you and the edge. Now bash the enemy with your limbs and ram into him until he falls out of the ring.

This tactic requires persistence—your opponent won't fall off after only one hit.

You'll also have to be careful not to fall out of the arena yourself. This style of on-the-edge fighting may seem cheap (and similar to combat in BA Toshinden Remix), but it's an easy way to topple troublesome robots.



RELEASE DATE	DIFFICULTY	
August	Moderate	
PUBLISHER	% DONE	
T*HQ	100%	
THEME	PLAYERS	SIZE
Fighting 1	or 2	CD-ROM

SATURN



Beat up the bad guy enough and you can wield a special attack.

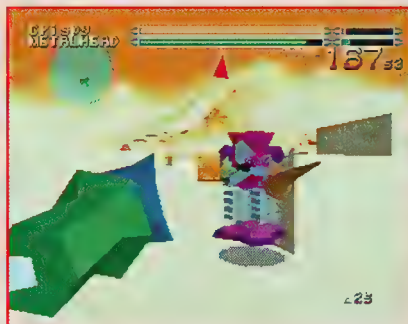

ROBO PIT

Aliens Invade The Saturn

Win a battle, win an arm. Combat is as simple as that in Robo Pit, T*HQ's new game of battling robots for the Saturn. This 3-D fighting game pits you against 101 robot opponents that are "armed" with weapon-tipped appendages. Each time you defeat a combatant, you nab both of its arms for use in later battles. (Lose a battle, however, and kiss your arms goodbye.) Some

of the game's appendages hold pretty standard weapons, like fists and swords, but later weapons can be downright weird. Win enough battles and you'll be able to snap on arms that shoot boomerangs or arms topped with suckers that yank opponents toward you. As many as 30 appendages can be collected in all.

Combat in Robo Pit takes place in several texture-mapped arenas. These arenas aren't too big, however, and

combatants have to be careful they don't leap out of the ring.

Before you can leap into battle, you'll have to construct your robot. Robo Pit lets you choose the body style and head of your mechanized fighter, as well as its legs and feet. The body style you choose also determines the kind of special attack your robot can perform.

Robo Pit has already been released for the PlayStation, but the Saturn version looks a bit sharper. The textures that are mapped on the arenas and robots of the Saturn version are more detailed. Still, the game plays the same as the above-average PlayStation title. ■



There are 30 arms to collect, although some are kinda silly.

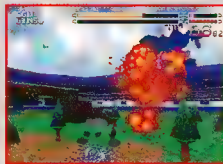

"As many as 30 appendages can be collected in all."



Once you tire of tackling the game's 101 robot fighters, you can take on a human opponent in Robo Pit's two-player, Split Screen Mode.

Don't play one,

Saturn

Nintendo

Playstation

Play them ALL

Psychopad

3 way play to handle multiple game systems.

HYPHER Programmable technology to combine your special moves and combos.

change of underwear not included.



www.actlab.com/gamegear

ESI
ELECTRO SOURCE, INC.
310-315-2600



SATURN



TETRIS PLUS

Get Trapped Between A Block And A Hard Place

As it possible, after so many years and so many different types, to make a puzzle game that actually has something fresh included? Lately, gamers have been lucky. Another one to add to the list is Tetris Plus.

In Tetris Plus for the Sega Saturn, gamers are confronted with options never seen before in the Tetris world, things like a Puzzle Mode and an Edit Mode. Of course, there's the Classic Mode and Vs. Mode—but would a Tetris game be complete without them?

The main part of the game seems to be the Puzzle Mode. In this mode gamers control the professor, a curious guy with an assistant who is on an expedition for

treasure. The professor obviously has the book smarts but not the street smarts since he quickly gets into trouble. As he walks into a chamber, he gets trapped and blocks begin to fall. Tetris begins.

The story line works well with the game considering it could've been taken too far and could've become too far-fetched. In the Puzzle Mode, gamers have the choice of exploring Mayan temples, Egyptian pyramids, the labyrinths of Knossos, Angkor Wat and a mysterious lost city. The hidden city gives players an additional 20 levels of Tetris action. With all of these cities to play through, the total number of levels is 100. Of course, this sounds impressive—and it is—but remember that each

level is harder than the next as gamers make their way through them.

The graphics in the game are similar to Baku Baku without the 3-D puzzle game, mind-boggling eye-candy isn't necessary. The cinemas and voices sound like something out of an anime show. The modes of play add variety to the game. Be sure to check the sidebar on the modes of play for more specific info on this.

Overall, Tetris Plus is everything the original was (being as fun) with the new Puzzle and Edit Modes added. It's nice to see something fresh happen with a game that's been done time and time again. ■



RELEASE DATE	DIFFICULTY	
September	Moderate	
PUBLISHER	DONE	
Jaleco	100%	
THEME	PLAYERS	SIZE
Puzzle	1 or 2	CD-ROM

Modes of Play

Tetris Plus features four modes of play: Classic, Puzzle, Vs. and Edit. Here's a rundown of each mode and what makes them stand out. As mentioned in the body text, Jaleco could've very well brought out a Tetris game that had nothing new. Since they added various modes of play and a story line, Tetris Plus is more than just another average puzzle game.

Classic Mode



Simple enough. The screen is split even if there isn't a second player involved. The blocks work as they always have.

Puzzle Mode



What the game really revolves around. The professor and his assistant and the adventures they embark upon. The spiked ceiling and the goal at the bottom are new additions to the Tetris world.

Vs. Mode



Not much to say here except, like the Puzzle Mode, the spiked ceiling and the goal are at the bottom of the level.

Edit Mode



One of the coolest features of the game. Here you can build your own level, choose the background and do a bunch of other cool things. Then you can save it. Note the EGM Level.

Daddy's Little Girl is Out to Save the World.

In the year 2069, Earth's no place for a lady. Alien pods have turned every living thing into hideous mutations.

One young woman, herself part alien, is Earth's last hope. Aided by her scientist father, her body is altered, transforming her into a harbinger of destruction.

Daddy's little girl doesn't cook, but she'll fry, bake or roast any enemy she sees. Cause in this world, you don't take prisoners... you eat them for lunch.

**NOW MUTATING
AT YOUR LOCAL
RETAILER ON THE
PLAYSTATION GAME
CONSOLE.**

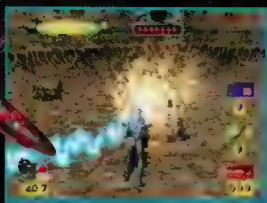

STEEL Harbinger™

She doesn't cook, but she'll fry, bake or roast anything she sees.



©1999 Windscape, Inc. All rights reserved. PlayStation and the PlayStation logo are trademarks of Sony Computer Entertainment Inc. Mutations is a registered trademark of Windscape, Inc. Steel Harbinger is the trademark of Windscape, Inc. All other trademarks and registered trademarks are the property of their respective holders.

<http://www.windscape.com>



SATURN



Alien TRILOGY

The Sci-Fi Saga Comes To The Saturn

Alien. *Aliens*. *Alien 3*. Who hasn't heard of the *Alien* series? Not only is it recognizable in the movie and comic book industry, but within the video game business as well. Alien TrilogY, the video game, was released by Acclaim for the PlayStation earlier this year. Saturn owners are still waiting, but not for too much longer. It may be worth it, as Alien TrilogY on the Saturn looks and feels just like the original.

Yes, it's another first-person shooter. Is it a good one? That will mostly depend on whether or not you liked the movies. If you didn't, you probably won't care too much for the game. It only offers six weapons (with a few explosives to throw as well)—all of which were seen in the movies. The levels are generally dark and dreary, and

they all look very similar.

So you won't find a lot of variety in the game, but what if you did like the movies? Then you'll probably love Alien TrilogY. The mood of the game comes straight from the movies: the excitement, the loneliness and the anxiety. Remember the nervousness you felt in the second film (*Aliens*) when the soldiers were walking down the dark tunnels? The only sound you heard was the motion tracker ticking as the evil creatures slowly closed in on the Marines. You'll soon get to re-live that whole

experience on your Saturn.

Not surprisingly, the plot starts out exactly like *Aliens*. The second movie was the favorite of the three among many fans; it was also the most action-oriented. You get to play the part of Ripley (Sigourney Weaver in the films). You are sent back to the planet LV 426 to see why contact with the colonists there has stopped. Of course, most of us know why the communications have

stopped, but that won't stop you from going back and eliminating the threat in a style that would make Rambo proud.

The general mood of the *Alien* films fit this type of game (a Doom clone) well, and this particular game does the movies justice. Alien TrilogY is just an overall well-made product that should be enticing to any fan of the great science-fiction series. ■

RELEASE DATE	DIFFICULTY	
September	Moderate	
PUBLISHER	% DONE	
Acclaim	100%	
THEME	PLAYERS	SIZE
3-D shooter	1	CD-ROM

DARE TO COMPARE



For authenticity's sake, many of the backgrounds and scenes from the game were taken directly from the *Alien* movies. Can you remember which movies these were from?



All movie scenes copyright © 20th Century Fox.



Just don't let the face-hugger into your digestive tract.



This alien is from the quicker red breed, seen only in *Alien 3*.

"...establishing
a new standard
in the platform genre."
-NEXT GENERATION

"Massive environment, go anywhere
gameplay and amazing depth give
Bubsy an entirely new perspective."
-DIEHARD GAMEFAN

"BUBSY 3D looks
to set the new standard
in action platform
gaming." -PSEXTRME



SEGA SATURN

RATING PENDING



wea
Visual Entertainment

ACCOLADE™

HIGHTAIL IT INTO A NEW DIMENSION!

<http://www.accolade.com> Call 1-800-245-7744 for product information

AKKOPY™ AND THE BUBBY CHARACTERS ARE REGISTERED TRADEMARKS BY ACCOLADE, INC. REGISTERED BY NEA.
[VARIOUS] LOCALIZING & LOCALIZATION, A VANDER PEGUE COMPANY. © 1998 ALL RIGHTS RESERVED. LICENSES FOR THIS COPYRIGHTED MATERIALS APPLIED FOR BY NEA. THE PLAYSTATION LOGO AND TRADEMARKS BY SONY CORP. REGISTERED BY SONY CORP. IN THE U.S. AND OTHER COUNTRIES. ACCOLADE AND SEGA ARE TRADEMARKS OF SEGA OF AMERICA, INC. © 1998 ALL RIGHTS RESERVED. THE BUBBY SERIES IS A REGISTERED TRADEMARK OF THE INTERACTIVE DIGITAL SYSTEMS GROUP, INC.

PLAYSTATION!

GAMER'S EDGE

Paris—it's a wacky place. Full of art, music and mimes. Why mimes? We don't know, but we do know that Paris is also the home of the Eiffel Tower. A big tower used for tourism. In *Twisted Metal*, the tower is also used to store weapons. Something is strange, though, as you drive near it. Besides the teleporter at the bottom, there's a remote-controlled explosive device at the base. One might think to pick it up and use it on an enemy. Of course, that can be done, but it would seem more fun to use it somewhere else...like maybe to blow up the tower. By placing it underneath the good ol' Eiffel Tower, near the center, getting far away and triggering the explosives, the tower topples over. Now you can drive on the rooftops of Paris, finding power-ups and outsmarting your enemies. Keep an eye out for other monuments and objects in the other levels of *Twisted Metal 2* to destroy. Talk about interactive backgrounds! Note: the version this was performed on was not a complete copy and may change in the final game.



TWISTED METAL 2

The World Tour Is Coming To Your Home

The last time we saw *Twisted Metal 2* it was simply a preview of what was to come. Sure, *EGM* got to play a bit of it, but after returning to the office, we wanted more. Sketches of the end cinemas and various levels helped our hunger but something was still missing. We wanted to hold the controller in our hands and play the game. We wanted the carnage of *TM2*. Our wait is over—but not yet complete.

As mentioned in last month's preview

feature, *Twisted Metal* is everything the first one was and so much more. So what has changed from the very early version we played some time ago?

The story is still the same. The evil Calypso has put together another deadly *Twisted Metal* tournament. The first left L.A. in ruins. Being a mastermind criminal (and unofficially a psycho) Calypso wasn't content. He wanted to go worldwide and that's what *TM2* is. The World Tour, in all of its twisted glory.

There are 12 characters to choose from. Now that *EGM*



actually has a playable copy of the game, we can show each of the players with their respective car. There is also talk of secret characters. If and when these are available, *EGM* will be sure to pass on the information to readers. Each of the characters has its own unique special weapon.

On top of the special weapon, players can obtain a whole arsenal of weapons. These include napalm, rockets, homing missiles, ricochet bombs, power rockets, remote explosives, a lightning bolt among others. Boy oh boy, if napalm won't take care

of an enemy, who knows what will. Of course players also have the standard machine guns. Each car has turbo boosters which run out of gas but can be replenished by finding the turbo power-up.

Can there be more? Of course! Each vehicle can also use a whole array of special moves. As mentioned



Now this is a strange thought. Usually windmills ground wheat to make flour. *Twisted Metal 2* might use these to grind flesh.



Wait a second! I thought Sweet Tooth was dead?



RELEASE DATE	DIFFICULTY	
November	Moderate	
PUBLISHER	% DONE	
SCEA	60%	
THME	PLAYERS	SIZE
Action	1 or 2	CD-Rom



The fire in Twisted Metal 2 looks incredible. Of course, visuals are one thing but, when it's knocking power out, the fire really stinks.

"...if napalm won't take an enemy out, who knows what will?"

in last month's preview, these moves are Up, Up, Down, Down type moves. Some include a force shield, a jump, a freeze beam and land mines. Since the copy of Twisted Metal 2 that EGM has is not yet complete, the special moves cannot be released (they may change). Fret not, when the moves are confirmed, EGM will do what it takes to get you the special moves as soon as they're available. From what we have heard about

the various moves, they'll be pretty cool looking as well as effective against the enemies gamers face in the levels of Twisted Metal 2.

Stay tuned to EGM in upcoming issues for more exclusive coverage of Twisted Metal 2 as it makes its way to being completed. Then it will be truly safe to say that EGM's hunger for harmless death and destruction will be satisfied...for now. ■

Gamer's Edge

Two-Player Strategy

Meet Joe Rybicki, assistant editor for *P.S.X.* and *CYBER SPORTS* Magazines. Yes, he is a busy man. But like all of us, Joe must take time out to see the new games that come through our offices. When Twisted Metal 2 arrived, the first thing that popped into many of our heads was Two-Player Deathmatch Mode. That's when Joe and I decided to see how TM2 fared in this department, since TM2 has a large array of weapons to find and utilize competitive play. Keep an eye on your radar as you drive in the various levels. So far, it seems like Paris and Hong Kong are ideal for two-player play. Of course, all the levels have their moments. Hiding in secret areas and hanging out on roofs is always a good thing to do when you're waiting for the enemy. Launch some napalm off of the roof or use a homing missile when you're far above on a ledge. This way it'll be almost impossible to miss your opponent. Joe, of course, was killed many times, but he put up a good fight.

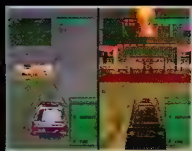

The Players

Axel



A tortured, tormented youth that's grown up to be one messed-up human axle.

Grasshopper



A dune-buggy with a need for destruction. What, no sand for you?

Hammerhead

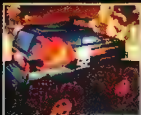

Children will be children. A bit more destructive, though, when in a monster truck.

Mortimor

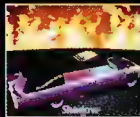

This guy takes his job a little too seriously. A good business person if you think about it.

Mr. Grimm



From the first Twisted Metal, except this time his cycle is extremely stylish.

Mr. Slam



Ever see *Falling Down*? If so, this guy is fed up. If not, let's just say this disgruntled postal worker.

Outlaw 2

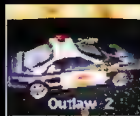

The first one left you breathless, the second will leave you screaming in pain. This cop is the law.

Roadkill



The original bad boy. His boomerang is back but his car is souped-up.

Specter



Hollywood star who wants to live his action movies. Nice rockets, face.

Thumper



Inner-city low-riders never used to have ground effects like this—a flamethrower!

Twister



Indy Car racing Mad Max style. Man, she is one hot-looking driver...for being hand-drawn, of course.

Warthog



He's a little dead, but he's still kicking—or should I say, firing? His barrage of missiles hurts plenty.

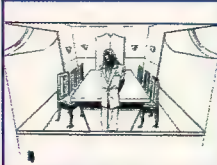

Calypso returns to watch his opponents twist each other.



Is that the flaming clown head on that stone wall? Hmm.

PLAYSTATION

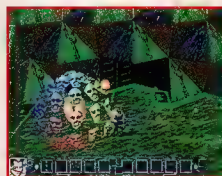
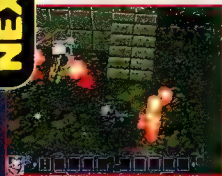
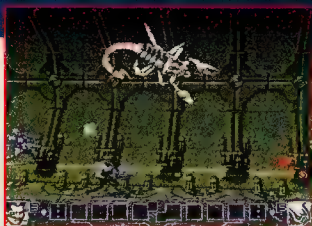
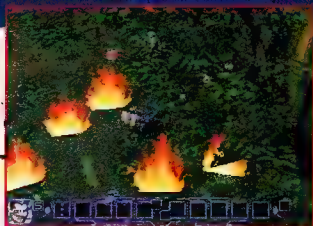

Contra

LEGACY OF WAR

The Classics Come To 32-Bits

Many video game enthusiasts may remember the game *Contra* for the 8-Bit Nintendo Entertainment System. It's a basic side-scrolling shooter that's considered one of the best classics of the genre. Since then, many sequels followed on several systems (including the Game Boy, Super NES and Sega Genesis—see Behind the Screens sidebar). Some were worthy follow-ups, some were

disappointments to fans of the series. Now for the first time, the company that has been bringing us all these *Contras*, Konami, is bringing the saga to the 32-Bit arena. Soon, PlayStation (and later, Saturn) owners will be the first to taste what Konami hopes will be a new era of *Contras*.

No one doubted that a 32-Bit *Contra* game would be made. After all, the previous installments collectively sold over 4 million units worldwide. The question is,

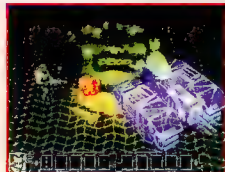
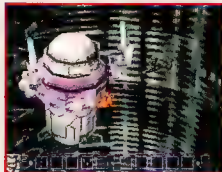

will this new sequel live up to its predecessors?

It's really too early to fairly judge right now. Randy Severin, senior product manager at Konami, isn't too wild about what he sees so far. He thinks that some of the levels are too bright and colorful, and some of the Bosses are not menacing enough. He knows that the first 32-Bit *Contra* title will be an important one for Konami, and he wants to make sure it comes out just right. The screen shots that you see on these pages, therefore, are subject to change.

But one thing that remains clear is that *Legacy of War* will follow the same tried-

and-true formula that made the other *Contra* games so successful. Basically, shoot anything and everything in sight. It's mindless and redundant, but hey, it's still fun.

The weapons that you'll see remain the same as in older *Contras* (see *Gamer's Edge* sidebar). The action, like we said, will stay the same as well. This time though, we'll get to see 3-D textured-

Gamer's Edge

Almost everyone's favorite *Contra* weapon is the spread shot. Will that carry over to *Legacy of War*? Here's a look at *Legacy's* basic weapons.

Machine Gun

Flamethrower

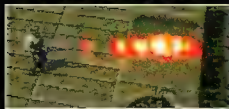

Spread Shot

Laser

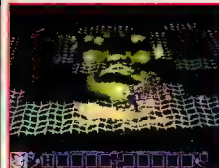
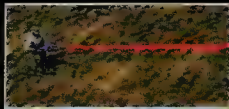

RELEASE DATE	DIFFICULTY
November	Adjustable
PUBLISHER	% DONE
Konami	80%
THEME	PLAYERS SIZE
Shooter 1 or 2	CD-ROM

Behind The SCREENS

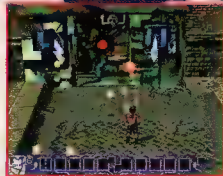

Like before, you'll have to shoot the red dots to pass the walls.



These gun pods are more dangerous with their guided lasers.

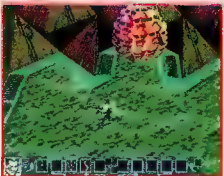

Learn this mid-Boss' patterns and you won't have any troubles.

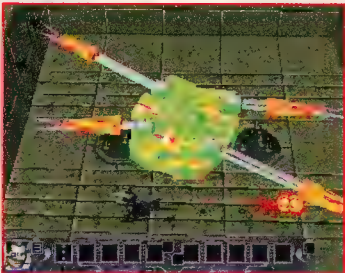

mapped environments. The levels look large and open, but your playing area will stay confined to a linear path.

Konami wants to take 3-D a step further and make a new visual option. This option is supposed to provide, "...an intense, lifelike combat experience, when viewed through 3-D glasses," as stated by Konami. Not much is known about this 3-D Mode, though it looks like what the old NES racing game, Rad Racer, attempted in the past—blurry red and blue images that didn't make anything three dimensional. Let's hope Konami stays away from this kind of cheap play.

Other features offered include the choice of four

"The question is, will this new sequel live up to its predecessors?"

different fighters, each with some weapons unique to him/her. Also, the selection of vehicles available has expanded to include tanks, jeeps, hovercrafts, helicopters and planes.

Of course, you'll be able to play two players at once. It wouldn't be a Contra game otherwise (let's forget about the Game Boy versions for argument's sake).

Konami is trying to make

sure that this new Contra will do the series proud. Often today, many companies get excited at the 32-Bit machines' graphical capabilities. Too much effort is put into making next-generation games look great, and the value of fun gameplay is pushed to the back burner. Fans will never put up with this for the first 32-Bit Contra, so Konami had better make sure their finished product is top-of-the-line! ■



See the sparkling power-up flying around? It begs to ask (as in all two-player Contra games), "Who gets to snag the new weapon?"

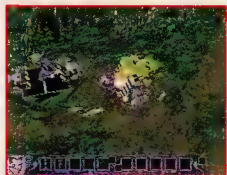
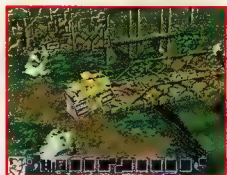

Most people may not remember all the Contra games that have been made over the years. Here's a nostalgic look at one of the best-running series in shooter-game history.

Contra-NES

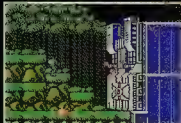

Super C-NES

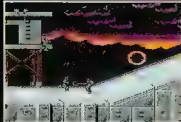

Contra Force-NES



Contra:The Alien Wars-GB

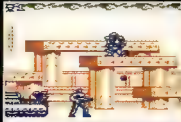

Operation C-GB

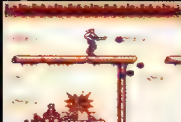

Contra Hard Corps-Genesis

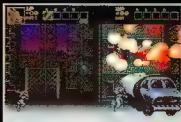

Contra 3:Alien Wars-SNES

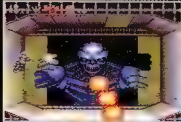

PLAYSTATION



Sadly, this explosion will be the last sight you'll see on the Super Chemical Reactor Level if you don't prevent the reactor meltdown.

DISRUPTOR

Your Mind Is The Ultimate Weapon

Can we use another Doom game? Universal Interactive Studios certainly hopes so. Their latest project is *Disruptor*. This will be the first title that UIS will publish for the PlayStation. They combined their Hollywood experience in production with the game-making talents of Insomniac Games, the developers of *Disruptor*.

This game offers you nine different weapons and five separate psionic powers (see sidebars).

Your missions will take you to many futuristic and fantastic worlds throughout our solar system. The 13 levels in 20 different

environments will test your 3-D shooting ability. You will visit strange areas from Jupiter's moons to Earth's orbit. Each level is unique in both looks and gameplay.

Just how can a first-person 3-D shooter be unique in gameplay? Each level has a different mission tied to it, which will leave you trying different strategies. For example, one level has you attempting to stop a super chemical reactor from exploding. You start out with 30 seconds, but you can find switches that will buy you more time. The layout of the level is fairly straightforward. You have to run through it as quickly as possible—don't stop to explore rooms or to kill

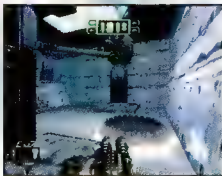
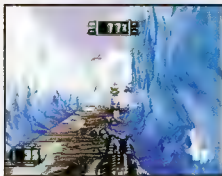

every enemy, otherwise you will lose the mission. On Mars, you have to find an ancient artifact discovered by some missing scientists. An electrical interference in the atmosphere prevents you from bringing weapons to the planet. Later, you can pick up guns dropped by enemies you

killed, but you'll have to rely on your psionic powers in the beginning to protect your well being.

The enemies have come a long ways in this type of game. Some of them are intelligent enough to not stay in one place while fighting you. You might see them duck

The Arsenal



Seven different weapons are available to you. Some of them share the same type of ammo, like the 180mm semi-automatic and automatic pistoles.

"Hopefully, the unique missions will help *Disruptor* stand out among the mass of similar-looking games."

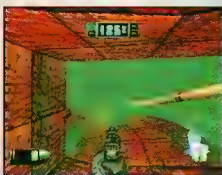

These psychedelic areas will recharge your psionic energies.

RELEASE DATE	DIFFICULTY	
November	Hard	
PUBLISHER	% DONE	
Universal Int.	80%	
THEME	PLAYERS	SIZE
3-D shooter	1	CD-ROM

STREET RACER

*It's a race.
It's a battle.
It's a blast.
It's coming this October.*



CHECK IT OUT! <http://www.ubisoft.com>

© 1996 Vivid Image. All Rights Reserved. © 1996 Ubi Soft Entertainment, Inc. All Rights Reserved. PlayStation, the PlayStation Logo and the PS Logo are trademarks of Sony Computer Entertainment, Inc. SEGA AND SEGA SATURN ARE TRADEMARKS OF SEGA ENTERPRISES, LTD. Nintendo and Game Boy are trademarks of Nintendo of America Inc. © 1996 Nintendo of America Inc. The ratings icon is a registered trademark of the Interactive Digital Software Association.

TOP-SECRET WEAPONS

Two top-secret weapons will be available to add to your arsenal. These weapons are only usable once but have that room-clearing personality that enemies just love to hate. If you find one, hold on to it like you would your security blanket. Unfortunately, we promised Universal Interactive that we wouldn't reveal the names of these weapons until they look like in action.

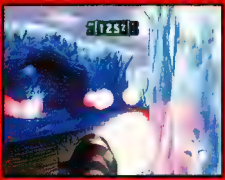

around the corner when the firefights are getting too heavy. It's not quite like challenging a human opponent, but it's definitely a step in the right direction.

Unfortunately, a Link Mode will not be made available to play another human (not that linking two PlayStations was that convenient in the first place). This adventure therefore, will be strictly a one-player experience.

Hopefully, the unique missions will help Disruptor stand out among the mass of similar-looking games. ■



These drones won't bother you. That is, until you bother them.

The Phase Repeater is the weapon of choice at EGM.

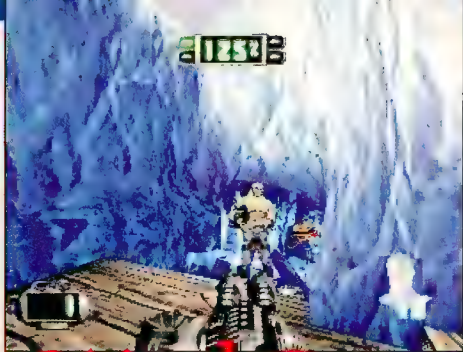

Mind Over MATTER

You cannot win by guns alone. As the game progresses, you will earn the right to use certain psionic powers. Don't forget, you'll have to use them efficiently. Make sure you know how much psionic energy is used for each power, less you find yourself in a difficult predicament. There's nothing worse than facing a rocket launching robot and not having enough psionic energy to turn your shields on.



Cost: 5—Shock is a short-range offensive weapon. It's pretty useless unless you are out of ammo. Try using your regular guns instead.



Cost: Variable—Use as a defensive and offensive tool. Explosive weapons can bounce off of you and hurt enemies around you.



Cost: 25—Guide this powerful missile into a group of enemies to kill them. As a bonus, they will leave you with recharges for your psionic energy.



Cost: 1—Drain is what replenishes your psionic energy. For the most part, you should keep your default ability on Drain so you'll never be short on energy.



Cost: 20 per 20 healed—Make sure you always have a minimum of 20 psionic energy points so you can heal when you're near death.

THE ONLY SPORT IN THE 23RD CENTURY



12 ALIEN RACES
SQUARE OFF IN THE
GREATEST CONTACT
SPORT EVER PLAYED.
DISCOVER THE
HIDDEN CHARACTERS
THAT STAND
BETWEEN YOU AND
PITBALL GLORY.

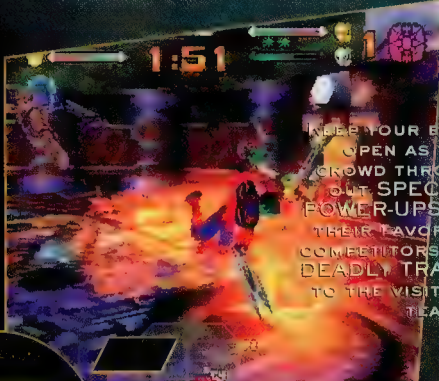

KEEP YOUR EYES
OPEN AS THE
CROWD THROWS
OUT SPECIAL
POWER-UPS TO
THEIR FAVORITE
COMPETITORS OR
DEADLY TRAPS
TO THE VISITING
TEAMS!

PITBALL™



USE THE UNIQUE
SPECIAL MOVES,
DEATH MOVES
AND ATTACKS
OF YOUR CHOSEN
WARRIORS TO
ANNIHILATE
YOUR OPPONENTS.



HIT THE COURT AND KILL
YOUR FRIENDS!
PLAY WITH UP TO
4 PLAYERS
SIMULTANEOUSLY
USING THE PLAYSTATION
MULTITAP.

EVERYTHING ELSE IS HISTORY

To order direct call: 1.800.245.7744



For Pitball hints and tips call
Accolade direct: 1.900.454.HINT

\$.99/Minute—If you are under 18, please get your parents permission
before making this call. Hints and tips available starting 11/96.

Visit the Pitball website at <http://www.accolade.com>

ACCOLADE

Pitball is a trademark of Accolade, Inc. ©1996 Accolade, Inc. All Rights Reserved. Licensed by Sony Computer Entertainment America for use with the PlayStation game console.
PlayStation and the PlayStation logo are trademarks of Sony Computer Entertainment Inc. The ratings icon is a registered trademark of the Interactive Digital Software Association.
THIS SOFTWARE IS COMPATIBLE WITH PLAYSTATION GAME CONSOLES WITH THE NTSC U/C DESIGNATION.

PLAYSTATION

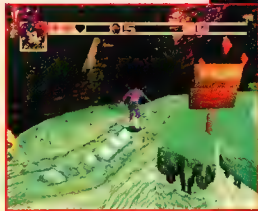

PANDEMONIUM

Jester Looking For Work

Any gamer who feels that the PlayStation has been recently left high and dry without any quality third-party titles coming out needs to take a look at Crystal Dynamics' latest chart stromer: Pandemonium. It utilizes a similar gaming structure as Crash Bandicoot as well as the better aspects of Sega's NIGHTS and blends them into a graphically outstanding title.

Players climb behind the reins of the mad jester-like hero to control him

through the 18+ levels of excitement. Perspective is in third-person point of view with your character always centered on the screen. Although technically the game controls like a side-scrolling title with each opposite direction on the keypad indicating either forward or backward in movement, it still appears to be a 3-D title. As stated earlier, the views automatically change at designated places in the paths. These mostly have you looking at your character from the side and from the rear, but occasionally you are found

trying to control your character for a few moments while looking him right in the face. This makes the title more interesting, but it forces the player to be extremely cautious while waiting for that unseen enemy to jump up right in front of him. The only control players have over the views at the time of this writing is the ability to zoom in or

out, giving the player a little more versatility.

While the background story still eludes many players, the gameplay is straightforward. Your job is to basically run through the mostly linear levels and collect as many diamonds as you can. In these levels there are also items such as heart health bonuses and stars to collect that help you along your path.

Enemies and the traps change in every level and the difficulty slowly increases as the player progresses. The most important tip to

"...there are over 18 levels each with separate sub-stages..."

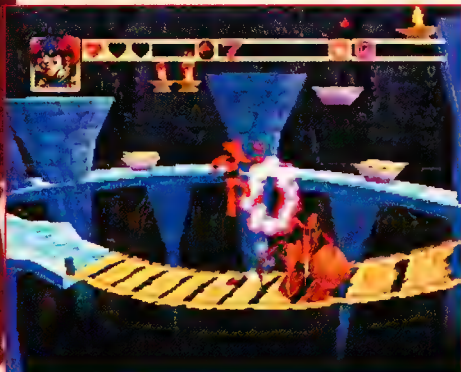

Misjudge a leap attack and you could end up as dinner for a ravenous beast such as this giant bridge-guarding spider.

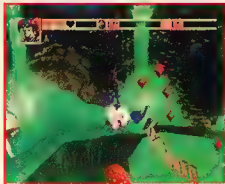

These treadmills roll quickly, use them for lightning-fast attacks.



Zoom capabilities give players a large view of the action.

DISRUPTOR

YOUR MIND IS THE ULTIMATE WEAPON.

INOMNIAC



Universal Interactive Studios, 100 Universal City Plaza, Universal City, CA 91606. ©1995 UNIVERSAL-INTERACTIVE STUDIOS, INC. DISRUPTOR IS A TRADEMARK OF UNIVERSAL INTERACTIVE STUDIOS, INC.
Licensed by Sony Computer Entertainment Association for use with the PlayStation game console. PlayStation and the PlayStation logo are trademarks of Sony Computer Entertainment Inc.
Call 1-800-771-8772 for information on Game Rating. The rating icon is a registered trademark of the Interactive Digital Software Association. Manufactured and printed in U.S.A.
THIS SOFTWARE IS COMPATIBLE WITH PLAYSTATION GAME CONSOLES WITH THE NTSC J/C DESIGNATION. U.S. AND FOREIGN PATENTS PENDING.

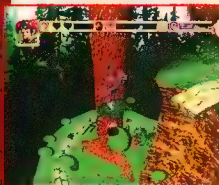
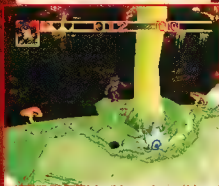

The gumdrop-looking items can be used to catapult you higher.



Some levels have hundreds of diamonds that are clustered in groups. Use well-placed jumps to grab them all with efficiency.

"...scaling the highest peaks of a walled castle."

remember—even while the difficulty is climbing—is not to give up on any level. Although they may seem tough, they can all be passed by using your memory. Even though this style of game can be beaten with correct timing and movements over and over again, it is still challenging for players to remember the exact timing of the traps and the enemy locations to get around them. Players will figure out how to finish the level after a few minutes of repeated attempts with the level layout like it is.

Right now there are over 18 levels each with separate sub-stages that stretch completion time longer than it first appears when the game is started. The levels are visually

appealing for players also. The design changes rapidly from one stage to the next. For instance, in the first part of a level you may be running around the outside of a giant tower looking for a key. And minutes later in that same level, you may be scaling the highest peaks of a walled castle. Many times players will find themselves only plowing through the stages just to see the next imaginative level that waits for them on the other side.

Pandemonium may disappoint players who were hoping that this was the PlayStation's chance to release a game to

combat the N64 and Mario. If players just take this title for what it is instead of what they hoped it would be, it would be much more appreciated. Sure it looks free-roaming and non-linear, but your paths are still tightly dictated until the end of the adventure. Small disappointing problems like this may hold it down, but they don't keep it down. On its own merits Pandemonium scores really high for the player with an open mind. No matter what players may have been hoping for, Pandemonium is still a fun-filled title with plenty of action to spread around. ■

Your most important weapon is your ability to jump. In classic Mario style, to defeat enemies, give them a bump on the head with the soles of your feet.

Most of the standard walking and flying enemies die from one hit and are easily dispatched from your path. Few other types need repeated hits (usually three) to get them to vanish. In these situations, you can continue to jump vertically on the creature's head (or head-like apparatus) by holding the Jump button while staying centered on the nasties' head. Most of these creatures don't move, making it even easier for them to be killed. All you need to do is hit them once and keep jumping as your character holds steady.

Another useful attack seldom found in games like this is the ability to jump forward while skipping off of the enemies' dome-pieces in front of you. This move is really fast and efficient, but it does take some practice to perfect. Jump too late and you will land in the creature's lap (and take damage). Jump too early and you just clear the creature.

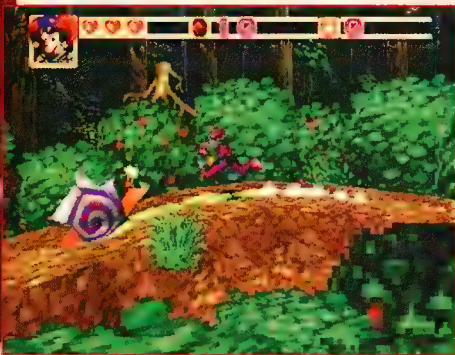
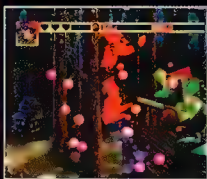

Stay out of the slime trail behind this snail, or you will slide uncontrollably into him and lose a precious point of health.

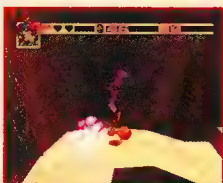

RELEASE DATE	DIFFICULTY	
November	Moderate	
PUBLISHER	% DONE	
Crystal Dynamics	75%	
THEME	PLAYERS	SIZE
Action	1	CD-ROM

Did Mom tell you it's never ok to play with your food? She's wrong.



Get ready for stick-to-your-ribs adventure!

- * 23 levels of wild, prehistorical fun.
- * Fantastic Graphics, animation, and sound.
- * The biggest, baddest, *hungriest* end boss ever.

"Prehistorik Man is a game that blows me away. I have but 3 words...go buy it!"

-K. Lee, Gamefan Magazine

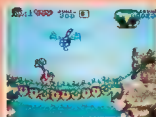
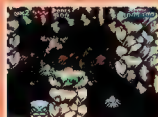
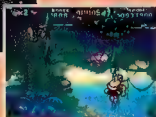

©1994 Titus Software Corporation

WANTED: brave adventurer, to risk life for missing treasure and beautiful girl. Yellowbelly cowards need not apply.



Can you handle the challenge?

- * Tons of hidden treasures and power-ups.
- * 17 action-packed levels to explore.
- * Stunning sights, sounds, and music.

"Ardy Lightfoot out-foxes the competition!"

-Nintendo Power Magazine

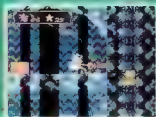
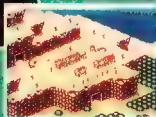

©1994 ASCII Corporation. All rights reserved. Licensed to Titus Software Corporation

Once upon a time, there were three little pigs...



...but these ain't just any piggs--They're superhero swine on a mission.

- * 6 hilarious, butt-slammin' adventures.
- * Extreme graphics and animation!
- * Battle against the most evil invention of all time.

"A clever, fun, action romp."

-Nintendo Power Magazine

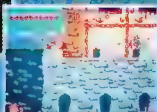

Blizzard, Star Wars, and Star Wars: The Phantom Menace are trademarks or registered trademarks of Lucasfilm Ltd. ©1997, Lucasfilm Entertainment Services Ltd.



Rent these exciting titles today at



BLACK & WHITE VIDEO is a registered trademark of Black & White Entertainment, Inc. ©1997, Black & White Entertainment, Inc.

PLAYSTATION

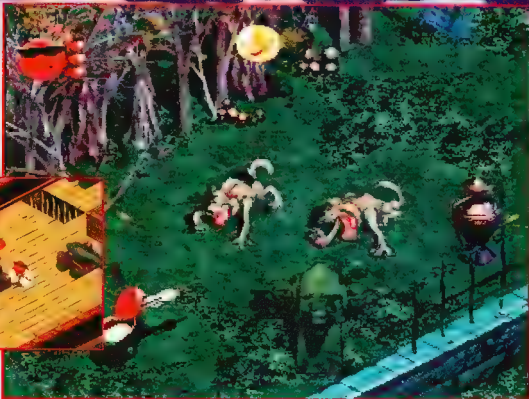
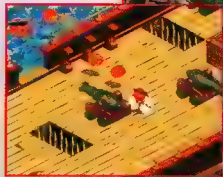
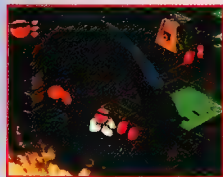

SPOT GOES TO HOLLYWOOD

Hang Out At The Coolest Spot In Tinsel Town

The days of 7-Up are over. It was a good drink, but Spot had to move on. He was destined to be more than just a mascot for a soda. He has become his own person—a character separated from the rest of the mascots of the world. Spot has become...well, cool.

Many gamers have seen shots of this game on the back of Sony PlayStation boxes or in *EGM* before and probably liked the sharp graphics with a

cartoony feel. We've finally been able to play a preview of it and so far it measures up to the hype.

Cool Spot is making his way through level after level—each with its own movie genre—trying to get out of the wacky film world. So how'd Cool Spot get in this pickle to begin with? After getting released from a movie theater's pop machine, Spot sneaks into the projection room. From there the fun starts. He should've never played

around with that darned projector—that's how he gets warped into the weird world where the game takes place.

The levels are set up like *Zaxxon*, in a three-quarter perspective but with a twist. Instead of just going in one direction all the time, Spot will go all over the place to make his way through each level.

Gamers will find stages that resemble *Indiana Jones* (i.e., the mine cart scene), a horror flick taking place in a large mansion and a typical swashbuckling pirate movie

complete with a giant octopus. With this many levels, players will be kept busy. Fret not, the red one still has his sparkling bubbles that made their appearance on the original game for the Genesis.

Keep an eye out for the 2-D characters thrown together with 3-D graphics for an interesting combination that's animated like a cartoon. Leave it to Virgin with their platform games to always



Space: the final frontier. These are the Journeys of a little, red dot...that flies around in a pop-bottle ship and destroys aliens!

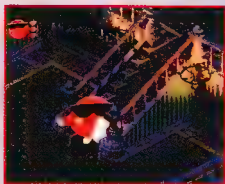

Each of the bonus rounds has its own film genre.

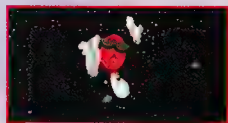

RELEASE DATE	DIFFICULTY	
October	Hard	
PUBLISHER	% DONE	
Virgin	100%	
THEME	PLAYERS	SIZE
Action	1	CD-ROM



White-water rafting? This is one of the things Spot can do.

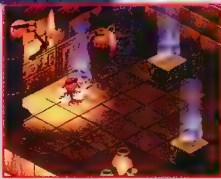

Once thought to be a bleemish, little red dot, he now isn't either here.



I've never personally seen a giant octopus, but I suppose they could be purple. Anything can happen in Hollywood!

have awesome character animation, examples being *Aladdin* and *Jungle Book*. The 3-D rendered backgrounds with 2-D animation in the foreground is similar to what Disney used in *Beauty and the Beast*. The outcome is what Mark Kelly, executive producer for Spot Goes to Hollywood, calls "outstanding." It's safe to say that EGM agrees. The graphics in Spot are flawless.

Gamers will fight hordes of Quasimodos in the mansion's

bell tower to swingin' salmon on the pirate ship. In each of these levels, Cool Spot can find a whole array of different items. The standard item, like in the old 16-Bit version, is the red dots. Since we're dealing with a 32-Bit world in a 3-D world, some new items have been added. Included are the "Hollywood Walk" stars, special letter coins, take-boards—which act as half-way markers—and movie reel warps which transport Spot to special areas.

When Spot collects all of the stars, an extra life is given. If all of the stars are

obtained from all the levels a special ending sequence is enabled. This includes segments of the game that didn't quite make it to the final cut.

Now that Cool Spot is breaking into new worlds, how long will it be until he makes his way to the 64-Bit realm—specifically onto the Nintendo 64?...Hmmm. ■

LEGAL TROUBLE

Why is it that whenever something funny comes along, these guys and gals called lawyers step in and start talking about these things called laws and even worse lawsuits?

Perhaps nothing major ever happened during the making of Spot Goes to Hollywood, but some of the other companies' lawyers made a stink when presented with a few of the parodies in the game. For instance, some of the levels were parodies of movies like *Blade Runner*, *Terminator*, *Predator*, *Tron* and *Aliens*.

These movie house lawyers said, "NO," and that's as far as the idea went. But don't get angry just yet. There is hope. By collecting all of the Walk of the Stars stars in the entire game, Spot will get a special ending with the "making of" included. In this cinema, some of the parodies that didn't make it into the game will be shown. You've gotta love hidden stuff!

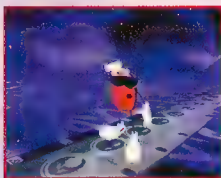

"Who would've thought a little red dot could do all this and so much more!"



Bonus areas within each level give players an opportunity to get some dots and the 1-Up giving stars. Be quick, there's a time limit.

Gamer's EDGE

Bosses

Level 1: The pounding and spitting giant octopus at the bow of the ship shouldn't be too much of a problem as long as you avoid his arms and cannon fire from above. Walking back and fourth across the ship is the best movement.

Level 2: The Spider's Lair is enough to make anyone with arachnophobia a little jittery. This one is obvious but avoid the spider at all costs. Good luck.

Level 3: You've finally made your way to the top of the mansion/bell tower. Defeat the Count by avoiding his bat and swoops while throwing plenty of deadly sparkles his way. Be careful not to fall off of the edge.

Level 4: Keep on target...the sci-fi style of this level will keep you at attention all the way up until the end when you face the "machine gun-packing, laser-blasting, horning machine-firing, big ol' ship" according to Mark Kelly, executive producer for Spot. Enough said.

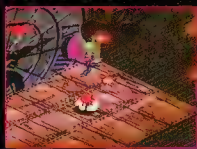
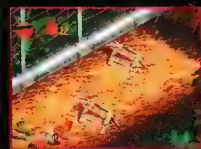

PLAYSTATION

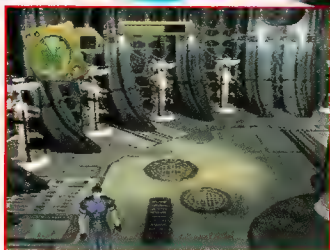

Perfect WEAPON

The Ultimate Battle Is The One You Fight Alone

What do you get when you mix Resident Evil with Tekken 2 (with a splash of Final Fight for flavor)? You get Perfect Weapon.

American Softworks Corporation (ASC) in conjunction with Gray Matter Inc. (the developers) is bringing to the PlayStation a game that covers a myriad of video game genres, and yet, cannot be defined as belonging to any one of them.

Perfect Weapon has exploration and puzzle elements similar to those of Resident Evil and Time Commando. When enemies are encountered the focus is shifted to combat.

You could be fighting a group of enemies who surround you, like Final Fight games but in 3-D. The attacks are not confined, however, to simple punches and kicks. The controls during fighting are very much like that of the Tekken games: independent left and right punches and kicks. Also like Tekken, many combos and throws are available. All together, you can perform over 100 martial arts moves which are derived from a multitude of real-life fighting styles, like praying mantis, drunken monkey and kickboxing.

This attention to fighting details is unprecedented. Sure, many one-on-one fighting games may have more moves.

However, when's the last time, you've played an adventure game with the fighting depth that even compares to Tekken? Not every move will be initially available. You'll have to advance through the game and fight the enemies that possess the different fighting styles.

The alien foes you will face are among the most challenging seen in any type of game. Up to 20 different species will inhabit the different levels. Each enemy is rendered in realtime and will fight you from any angle. Each race also has a distinct fighting technique. Some tend to throw, others like to punch. You'll be truly impressed with the artificial intelligence (see sidebar) when you are surrounded by five goons, all of whom are sitting back, waiting for the right moment to attack in unison.

These aliens inhabit five distinctly different worlds: desert, ice, forest, Chinese garden and industrial cyberhell. These

Behind The SCREENS

Perfectly Intelligent

ASC terms Perfect Weapon's artificial intelligence as BAI, or Behavior Artificial Intelligence. Enemies will learn patterns in your attacks and compensate for them. For example, if you're constantly foot sweeping your opponent, he will start to jump over the sweeps. This behavior of Perfect Weapon's enemies is quantum leaps over that of the bad guys of the Final Fight and Double Dragon days. You can forget about just tapping your Attack buttons over and over to defeat your foes.

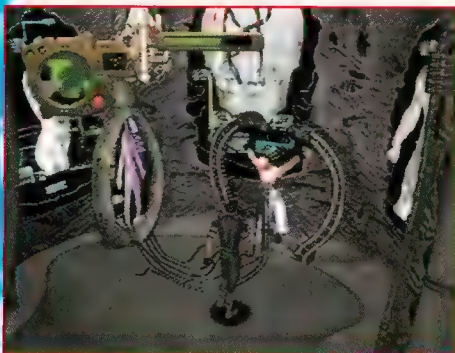

GAMER'S EDGE

Learn all of these moves well, young grasshopper. Simple punches and kicks won't cut it. Finding the right combination of moves is a necessity in becoming the Perfect Weapon. (This is just a sample of the many combos available.)

- , □ Jab-uppercut combo
- △, △, △ Triple uppercut combo
- + △ Spinning punch
- X or O Sweep kick
- Hold L1, release, O Helicopter kick
- , X Flip throw
- △, X Knee to body
- , X, X Super combo

levels are all beautifully prerendered and show off amazing details and light sourcing. ASC is boasting that when PW is completed, it will contain 1100 to 1300 separate 3-D locations (though that's not as impressive as it sounds; a large portion of those are actually the same locations viewed at different angles). And to complement the looks will be the soundtrack. Each level's music is amazingly ambient, moody and exciting.

Why are you (playing the part of Commander Blake Hunter) running around alien worlds in the first place? It seems this evil alien fiend thinks of you as Earth's best combatant. He kidnaps you to put you through a test of survival in

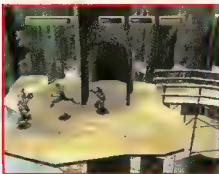

order to study you. His end plan is to have you become a Perfect Weapon, so that he could take those instincts and skills from you. Flattering that he thinks so highly of you, isn't it? Your job then, is to find your way out of this mess and get home.

ASC is so confident that Perfect Weapon will sit well with gamers, that a sequel named Final Weapon is already being planned. Meanwhile, PlayStation owners can look forward to seeing this truly ambitious title in November (with the Saturn version being released first quarter 1997). ■

RELEASE DATE	DIFFICULTY	
November Adjustable		
PUBLISHER	% DONE	
ASC	80%	
THEME	PLAYERS	SIZE
Action	1	CD-ROM



Gamer's EDGE

The Longest Battle

According to David Klein, the president of ASC, the fight with the final boss (who, at ASC's request, shall remain nameless) will be "the longest fight in video game history."

Why? This last boss has a computer that supplies him with regenerative powers. Players will have the option of shutting down this computer, if they can solve the puzzle. If they don't, then they'll be fighting a fierce battle with a seemingly invincible opponent.

Klein tells us that fighting the regenerating boss may take upward of 30 to 35 minutes. Even if the computer is shut down, a good player with plenty of health power-ups may find the battle lasting at least 20 minutes.

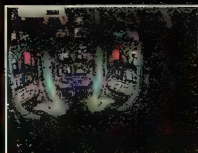

It's highly recommended that you shut this computer down.



The different-colored enemies indicate their rank and power.

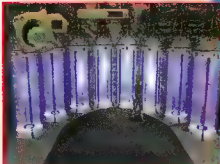

Blake finds the bodies of great warriors from other worlds.

Behind The Screens

Here's what Perfect Weapon's animated characters look like before they become animated video game characters. After the idea of a game is first formed, some sketches are drawn (lower left) to visualize those ideas. Later, wire frame models are designed on computers (lower right) to animate the characters.

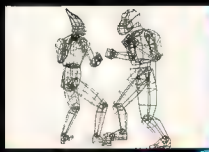
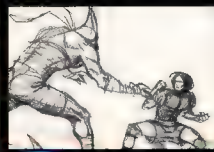

PLAYSTATION

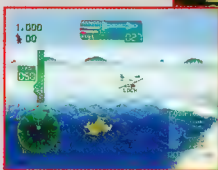
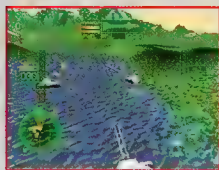

BLACK DAWN

Terrorize The Terrorists

Poor ChopLifter. The classic search-and-rescue shoot-'em-up has been ignored by the recent comeback of oldie-but-goodie games and arcade classics. While a new generation of game players is tearing through updated versions of Tempest, Robotron and other classics, ChopLifter seems to have become lost in gaming's good old days.

Or maybe not.

Virgin's upcoming Black Dawn looks suspiciously like a next-generation version of ChopLifter. Although much of this 3-D helicopter combat game is spent blowing bad guys out

of the sky, some missions send your chopper out to rescue soldiers and hostages. When your gunship touches down to pick up the passengers, they hop into your helicopter in a helter-skelter fashion fans will find familiar.

Similarities to classic games aside, however, Black Dawn is much more than ChopLifter revisited. Players pilot a Mohawk attack helicopter for Black Operations, an elite anti-terrorist force. Black Ops has been deployed to seven world regions, including the Arctic, the Arabian Desert, the jungles of South America and even New York City's Central Park. In addition

to these locales, pilots can soar through hidden bonus levels to pick up extra arms and armor.

Most regions have an average of five mini-missions to complete, and it is the game's variety of missions that sets it apart from other flight-combat titles. Some missions are simple search-and-destroy outings, but others have you rescuing hostages or transporting soldiers into enemy territory. When pilots complete a mission, they are radioed an in-flight briefing on their next assignment. Only by completing all the mini-missions do pilots clear one of the game's areas. Adding to the tension of each mission is Black Dawn's soundtrack. The game contains 16 fully orchestrated tunes, and the music speeds up as players near the end of each mission.

Black Dawn is being developed for Virgin by Black Ops, the same team that created Agile Warrior. But the game is a big improvement

over Agile Warrior—it has more missions and enemies, smarter AI and much sharper graphics. Pilots can fly their choppers from inside the cockpit, from a chase view or a third-person, wingman view (which works well when trying to locate hostages). Pilots

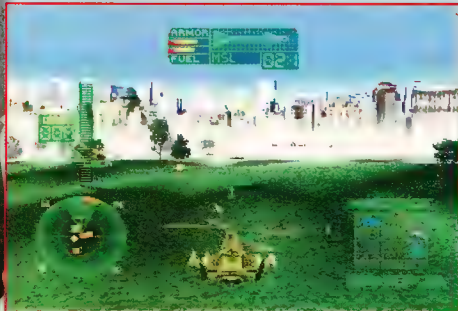

The hostages could use a lift to a friendly air base, so be nice and give them a ride. Just be careful not to hit them with stray bullets.



The Central Park terrorists are about to ruin everyone's picnic.

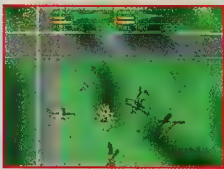

The Deathmatch Mode pits two players against each other.

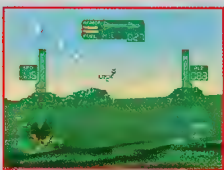
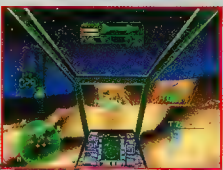



**STRIKE HARD
STRIKE FAST**

STRIKE POINT™

Navigate through 10 different landscapes, destroy everything in your path, and race to save the world from ecological Armageddon. Play Strike Point – the ultimate 3D fighter simulation game available for PlayStation.



TECHNOS
AMERICAN TECHNOS INC.

©1996 Microsoft Corporation. All rights reserved. PlayStation and the PlayStation logos are trademarks of Sony Computer Entertainment Inc. All other names are trademarks of their respective owners.

2010 N. First Street
San Jose, CA 95131

Behind The SCREENS



can also look (and shoot) to the left and right while playing in the cockpit view.

When players down enemy aircraft, power-ups hover above the foe's flaming wreckage. Some power-ups simply replenish armor or fuel. Others yield more missiles and bombs—such as napalm and unguided rockets.

Flight in Black Dawn is much simpler than in a sim. Players can choose between two Flight Modes: one that

lets them change altitude by changing the direction of their chopper's nose, and one that keeps the chopper at the same altitude no matter what direction the chopper is facing. The first mode is more realistic, but the second makes attacking ground targets easier.

This is one of the few flight games with a Two-Player Mode that doesn't require two PlayStations and a link cable. Called the Death-match Mode,



The bad guys are nice enough to leave power-ups when they die.

the two-player game has pilots battling each other while viewing their choppers from an overhead perspective.

Another unique feature is Black Dawn's computer-controlled helicopter wingman. This second attack chopper assists players as they go about their missions. It attacks targets that get away from the player and it will even cover the player's helicopter when it picks up hostages.

You'll appreciate the second chopper's help. Considering how many bogies fill Black Dawn's unfriendly skies, players will need all the help they can get. ■

Gamer's EDGE

There's a whole lot of bad guys in Black Dawn, and they're often all gunning for your helicopter at once. Fortunately, your chopper is so maneuverable it can use a defensive tactic usually found only in Doom-style games—strafing.

The top left and right joystick buttons send your chopper zooming sideways to the left or right, just like the strafe buttons do in Doom. Players can use these buttons to dodge enemy fire, but they can also turn the nose of the chopper toward the enemies while dodging. This tactic lets pilots fire off a few bullets or missiles even when they're on the run from enemy weaponry.

"Power-ups hover above the foe's flaming wreckage."

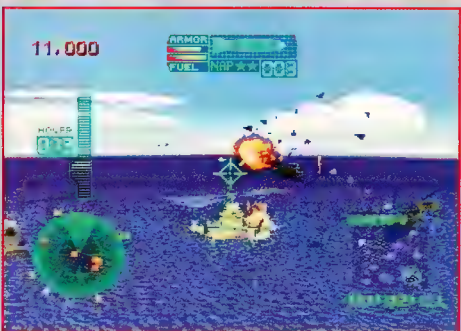
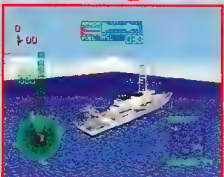

Enemy aircraft shed a ton of shrapnel when you nail them with your guns, and their glaringly bright explosions light up the battlefield.

Black Dawn is the second PlayStation game from Black Ops, the development team behind Agile Warrior. EGM talked with Black Ops President John Botti and Black Dawn's lead programmer, Will Botti (John's twin brother, by the way) about this intense flight game.

EGM With its hostage-rescue missions, Black Dawn looks like it was heavily influenced by ChopLifter. Was it?

WB: Botti: Quite honestly, yes. ChopLifter was one of my favorite games, and it definitely was an inspiration. We actually thought about doing a ChopLifter 3-D, but that wouldn't have played to our strengths in terms of the other elements of the shooter genre that we wanted to incorporate in the game. We wanted to have more than rescue missions.

EGM: One neat feature of Agile Warrior was that it let you play audio CDs in the PlayStation while playing the game. Does Black Dawn have the same feature?

WB: You can do it, but it's not going to work too well. The game accesses the CD a lot for in-flight briefings and other sound effects, so you'll end up hearing brief snatches of your music.

EGM: At first glance, Black Dawn looks similar to Agile Warrior in terms of graphics and gameplay. How is the game new and improved?

JB: Botti: We're using the guts of the 3-D engine that was developed for Agile Warrior, but Black Dawn's really a drastically different game. There's been a lot more time spent on the AI. The frame rate is a lot faster, and you can have literally dozens of things on screen. The skies can be cluttered with enemy helicopters or friendlies, and the frame rate doesn't suffer.

RELEASE DATE DIFFICULTY

October Moderate

PUBLISHER % DONE

Virgin 80%

THEME PLAYERS SIZE

Flight Sim 1 or 2 CD-ROM



Let Sonic and Tails Clean Your SEGA SATURN™



©1992 SEGA



©1991 SEGA

Introducing the **Cleaning Kit for Sega Saturn** - A two part, easy to use cleaning tool designed specially to clean and maintain your Sega Saturn System and all your games. Attached with soft bristles made of micro fibers, the self loading Cleaning Disc cleans the lens effectively without damage. You can also clean your Saturn software with the ergonomically designed Cleaning Pad and Liquid Cleaning Solution included. As an added bonus, you can watch Sonic the Hedgehog and his pal Tails doing the cleaning right on your T.V. screen!

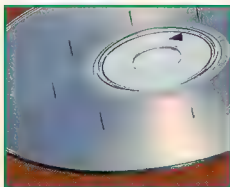

Attached with micro fiber bristles, the Cleaning Disc cleans the lens without harm.



High Quality Cleaning Pad to wipe discs without scratching.



Specially formulated Liquid Cleaning Solution to be used with Cleaning Pad.



**So just sit back,
and let Sonic and Tails
clean your SEGA Saturn.**



TM

Distributed by:
C-SEVEN International
2543-C Pacific Coast Highway
Torrance, CA 90505
Phone: (310) 530-9994
Fax: (310) 530-9995
Email: CSEVEN@NOWCOM.COM



This official seal is your assurance that this product meets the highest quality standards of SEGA™. Buy games and accessories with this seal to be sure that they are compatible with the SEGA SATURN™ SYSTEM.

SEGA, Sonic the Hedgehog and all related characters and indicia are trademarks of SEGA ENTERPRISES, LTD. ©1991 SEGA © 1992 SEGA All Rights Reserved

SEGA AND SEGA SATURN ARE TRADE MARKS OF SEGA ENTERPRISES, LTD. ALL RIGHTS RESERVED

PLAYSTATION



Gamer's Edge

Bilsten

The resident Boss, Bilsten, isn't anything special in terms of fighting ability, but a simple strategy can take him out. He relies on his brute strength to lower your power bar to the subterranean level. He has little special attacks or speed moves but can seriously beat an opposing character to a pulp, quickly. The way to win against him is to burn-rush him and hit with the biggest combos. Just TRY to get him before he gets you. It's a simple strategy but it's harder to implement than it is to talk about.



STAR GLADIATOR

Capcom Rockets Into 3-D

Even with the continued popularity of the Street Fighter series, Capcom refuses to be content with just two-dimensional fighters in their corner. Besides lending a valued hand in the development of Toshinden 2, little progress has come from this industry giant in the realm of 3-D fighting. This attempt to create a marketable product brought gamers what they demanded from a 3-D arena-style title bearing testimony to the capability of the company. This new title is called Star Gladiator.

Star Gladiator is a platform arena-based fighting title similar to its half-parent Toshinden 2. These stages are each unique to a certain character as in other titles and change as the player advances. They all seem to have a dominant "tech" feel to them, no matter what the theme is.



Three caps Up make Gore grow to giant size. Talk about rangal

Graphically the title is the cleanest seen in a long time. The stages and the characters are all brightly colored and use little darkness in the backgrounds to mask graphical flaws as many titles do. This gives the title a strong basis from which the rest of the game is built on.

With characters original to this title alone, Star Gladiator gives players the chance to try their hand at any of the races involved in this futuristic combat situation. There are some similarities between a few of the characters in current titles, but as a whole, they are all unique and can be adapted to



Finish off an opponent and watch the power be drained from his/her body. Use this chance to get a few cheap shots on his/her corpse.

a wide range of playing styles.

The action is based on the hovering arena where the non-cautious fighter can take an accidental plunge and forfeit the round. Character controls in this arena allow rolls and shuffles to the left or right as well as forward and backward movement. All the

characters' attacks are similar to the standard set by Street Fighter, making adaptation for players who are used to SF extremely quick.

Character moves are based around the range of some type of hand-held weapon the character wields. These, along with the occasional punch and kick, keep opponents at bay



RELEASE DATE	DIFFICULTY
November	Variable
PUBLISHER	% DONE
Capcom	70%
THEME	PLAYERS
Fighting 1 or 2	CD-ROM

THE 'STAKES ARE HIGH!

ENTER THE SWEEPSTAKES TO WIN AN NBA JAM EXTREME ARCADE GAME.

COMING TO
PLAYSTATION™
SEGA SATURN™ &
WINDOWS™ 95
IN NOVEMBER



NBA JAM EXTREME



MULTIPLE CAMERA ANGLES AND INSTANT REPLAYS!



BIG HEAD MODE AND TONS OF OTHER SECRET CODES AND HIDDEN PLAYERS!



ALL-NEW 'EXTREME' BUTTON: TRIPLE SPEED RUNNING, PASSING AND A WHOLE NEW LEVEL OF JAMS!

SWEEPSTAKES RULES:

1. No Purchase Necessary: To enter, mail the entry form or a standard size postcard containing name, address, and phone number to NBA Jam Extreme Sweepstakes, Ziff-Davis Publishing Company, 1920 Highland Avenue, 2nd Floor, Lombard, Illinois 60148. No purchase or payment of any money is necessary to enter. One entry per household. All entries must be handwritten. Mechanically reproduced entries will not be accepted. Entries must be received by November 1, 1996. All entries become exclusive property of Ziff-Davis Publishing Company (Ziff-Davis) and will not be acknowledged or returned. Ziff-Davis assumes no responsibility for lost, misplaced, late, illegible, incomplete, postage-due, or misdirected entries.
2. Prize: 1 Grand Prize: Grand Prize winner will receive one (1) NBA Jam Extreme arcade unit. Grand Prize has an approximate retail value of \$4,000. Winner will be determined by a random drawing from all valid entries by Ziff-Davis whose deadline see final. Drawing to be held on or about November 15, 1996. The Grand Prize will be awarded. Prize winner will be notified by mail. Prize is non-transferable. No substitutions of prize is allowed, except at the discretion of sponsor and if featured prize become unavailable.
3. Odds of Winning: The odds of winning will be determined by number of valid entries received.
4. Eligibility: Sweepstakes open to residents of United States and Canada only, void in Puerto Rico and the Province of Quebec, and where prohibited. Non-compliance with the time parameters contained herein or return of any prize/prize notification as undeliverable will result in disqualification and an alternate winner will be selected. Winner or their legal guardian must sign an affidavit of eligibility/release of liability/prize acceptance within 30 days of receipt or forfeit prize. If winner is a Canadian resident, in order to be declared the winner, he/she must first correctly answer, whose assistance of any kind (whether mechanical or otherwise), a time limited mathematical skill testing question to be administered by mail or by telephone at a mutually convenient time. By acceptance of prize, winner agrees to the use of their name and/or likeness for purposes of advertising, trade, or promotion without further compensation, unless prohibited by law. Employees of Ziff-Davis, Acclaim Entertainment, Inc. and their respective affiliates are not eligible. Neither Ziff-Davis, Acclaim Entertainment, Inc. nor their affiliates, subsidiaries, divisions, or related companies are responsible for any damages, losses, or expenses that consumers might incur as a result of this sweepstakes or receipt of prize. Winner accepting prize agrees that the prize is awarded on the condition that neither Acclaim Entertainment nor Ziff-Davis, and their respective agents, representatives, and employees will have any liability whatsoever for any injuries, losses, or damages of any kind resulting from acceptance, possession, or use of the prize. Winner further acknowledges that neither Acclaim Entertainment, Inc. nor Ziff-Davis has made nor is an any manner responsible or liable for any warranty, representation, or guarantee express or implied, in fact or in law, relative to any prize, including but not limited to its quality, mechanical condition or fitness.
5. Winner List: For a list of winners, send a stamped, self-addressed envelope to NBA Jam Extreme Sweepstakes Winners, 1920 Highland Ave, 2nd Floor, Lombard, IL 60148. Requests for winners lists must be received by December 1, 1996. Allow 4 weeks for delivery of winners list.
6. Restrictions: Void where prohibited or restricted by law. All federal, state and local regulations apply.
7. Sponsors: This sweepstakes is sponsored by Acclaim Entertainment, Inc. The NBA and individual NBA Team designations used on or in this product are trademarks, copyrighted designs and other forms of intellectual property of NBA Properties, Inc. and the respective Teams, and may not be used in whole or in part, without the prior written consent of NBA Properties, Inc. © 1996 NBA Properties, Inc. All other material © 1996 Acclaim Entertainment, Inc. All Rights Reserved.

Fill out and mail this entry to:
SENDAI PUBLISHING GROUP, INC.
1920 HIGHLAND AVENUE SUITE 222
P.O. BOX 285
LOMBARD, IL 60148

(PLEASE PRINT)

NAME

ADDRESS

APT#

CITY

STATE

ZIP

DAYTIME PHONE ()

DATE OF BIRTH

E-MAIL ADDRESS

SYSTEMS OWNED (Check all that apply)

Saturn PlayStation DOS CD-ROM Windows 95 N64

SYSTEMS YOU PLAN ON BUYING (Check all that apply)

Saturn PlayStation DOS CD-ROM Windows 95 N64

HOW MANY GAMES HAVE YOU PURCHASED IN THE PAST YEAR?

ENTRIES MUST BE RECEIVED BY NOVEMBER 1, 1996





Use Vector's Head Laser to clear out a path in front of his mechanical body. If someone gets in the way, it could be all she wrote for that fighter.



Ringal's Flame Breath can take many opponents by surprise.



Size isn't everything—use speed to fight against power.

"...use(s) little darkness...to mask graphical flaws..."

long enough to build up a combo. If an enemy does move in too close, there are grappling moves to make that enemy change his/her mind and back off. Some of the characters have potent long-range attacks that can be used for the same effect as Ryu's and Ken's fireballs. Each of the characters can be chosen to fit a player's individual tastes depending if a player likes to be up-close and personal or keep the range advantage.

Useable game features in Star Gladiator consist of an Arcade Mode and a Two-player Mode, as well as variable difficulty settings for the beginning or highly-advanced

player. There is also a Practice Mode that can help anyone become a fierce fighter if they put in the time to develop their skills.

Players used to the Capcom tradition for fine fighting titles need to move on to Star Gladiators. Its imaginative gameplay will be welcomed by all combat lovers whether they are accustomed to the 3-D world or not. ■



"...attacks are similar to the standard set by Street Fighter..."



Saturn's Flying Torpedo attack is similar to the special move used by a sumo wrestler who has a fetish for fighting in bath houses.

Training Mode

Training Modes are becoming increasingly popular in fighting titles, but Star Gladiator went one step further and has incorporated a chain move diagram for each character. This tree formation can be seen in the upper right-hand corner of the Practice Screen. It is based on the character chosen by the player and shows the button combinations needed to pull off the most fierce characters moves.

Just start on the left and plan your course. Once you think you have mastered all there is in the Practice Mode by beating up on the defenseless enemy, you can select to make the confrontation more realistic. This gives the enemy freedom to defend himself/herself (and take the initiative) instead of just being a punching bag.

Gamers will soon realize that pulling off that five-hit killer combo is twice as hard against a character that has the smarts to break up the onslaught.

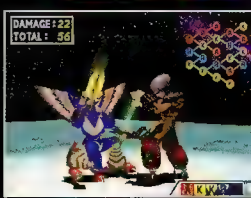

Spanish
Grand Prix

French
Grand Prix

Japanese
Grand Prix

Australian
Grand Prix

ICE TO WIN

Official Rules

1. To purchase necessary
2. To enter, complete official sweepstakes entry form located at participating retailer or hand print your name, address, city, state, zip code and daytime and evening phone numbers on a 3" x 5" piece of paper and include a Formula 1 game proof-of-purchase (EPC code or retail cash register receipt). In lieu of the proof-of-purchase, include a separate 3" x 5" card on which you handhand printed "Formula 1 Sweepstakes" and complete entry to "Formula 1 Sweepstakes", 969-G Edgewater Blvd., #755 Foster City, CA 94034.

3. Entries open as you wish. One entry allowed per envelope. Each entry must be mailed separately and received by January 15, 1997. Sponsor not responsible for lost, damaged, illegible, incomplete, postage due, mislabeled or late entries or mail. No mechanically reproduced or photocopied entries permitted.

4. First Grand Prix: One trip for two people to any Formula 1 Grand Prix race in the World. Trip includes round trip coach air travel from a major airport nearest to the winner's home to destination city, 7 days/6 nights hotel accommodations (double occupancy), travel to Formula 1 Grand Prix race and local ground transportation to and from airport and hotel (Approximate Retail Price Value: \$9300), race value may vary depending upon point of departure and location of race. Forty-five days advance notice required for travel. Trip must be taken by December 31, 1997. Block out dates may apply. Race dates and arrangements are subject to availability. Prizes (10):

any PlayStation with a PlayStation Formula 1 video game (Approximate Retail Price Value: \$269), Second Prize (25): any PlayStation Formula 1 video game (Approximate Retail Price Value: \$20), Tenth Prize (100): retail value of \$15. All prizes winners will be selected in a random drawing on or about February 1, 1997. Drawing will be conducted by an independent judging organization whose decisions are final in all respects. Trip prize won by a minor will be awarded to the name of the parent or legal guardian who must sign all required documents and in the case of Grand Prix, accompany minor on trip. Grand Prix winner will be notified by certified mail and required to sign an affidavit of eligibility and liability and publicly release which must be completed and returned within 7 days of notification or prize will be forfeited and awarded to an alternate winner. Travel companions, or their parent or legal guardian if companion is a minor, must sign and return a liability/publicity release form and insurance affidavit documents. First and Second Prize winners will be notified by letter.

5. By accepting a prize, winners consent to the use of their names and likeness for advertising and promotional purposes without additional compensation, except where prohibited. Winners also agree to release, discharge and hold harmless PlayStation, the respective advertising and promotion agencies and agents from all claims or damages arising out of acceptance, use, misuse of possession of any prize received in this sweepstakes.

6. Sweepstakes open to all legal U.S. residents, excluding Puerto Rico, 15 years of age or older, except employees of PlayStation, its affiliates, subsidiaries, distributor, advertising and promotion agencies and the immediate families of each. Void where prohibited, subject to federal, state and local laws and regulations. All entries become the property of the Sponsor and will not be returned.

7. Odds of winning depend on number of entries received. Prizes are non-transferable and no substitution or cash equivalent allowed except by the Sponsor who reserves the right to award a prize of equal or greater value if an advertised prize becomes unavailable. All federal, state and local laws on the prize grant the sole responsibility of the winner. All medals, gratuities and other law expenses not listed above are the sole responsibility of the Grand Prix winner.

8. All winners' names send a stamped, addressed envelope to "Formula 1 Winner's List", 969-G Edgewater Blvd., #755, Foster City, CA 94034. Requests must be received by January 15, 1997.

Sponsor: PlayStation, 969-G Edgewater Boulevard, Foster City, CA 94034.

WIN A TRIP TO THE '97 GRAND PRIX OF YOUR CHOICE!

Canadian
Grand Prix

Argentine
Grand Prix



Italian
Grand Prix

Brazilian
Grand Prix

SPORTS

EA SPORTS SETS UP AT THE LINE OF
SCRIMMAGE WITH MADDEN '97

This year, EA Sports hopes to throw the bomb and reclaim the Super Bowl of gaming from Sony Interactive Studios and GameDay, the winners of last year's gaming title.

It's football season again, and we at Team EGM are gearing up to hit the field with the latest news from the world of sports. In our last issue, we gave you a glimpse of some of the many football titles preparing for release on the home systems. Now it's time to take a closer look. For this issue, we bring you an interview with the godfather of football gaming himself, John Madden. Read what he had to say about the NFL, the upcoming season and his own long-anticipated game. We also take a detailed look at some of the strategy involved in Madden '97.

This month's previews section offers a lot of variety, with a first look at a Japanese wrestling game called Toukon Retsuden which Activision is translating for the U.S. market as Power Move Pro Wrestling. We also include a bowling game called Ten Pin Alley, the newest version of NHL for the Sega Genesis, the latest news on Waverace 64 for the Nintendo 64 and a

sneak peek at a new snowboarding game called Coolboarders. This game should be out in Japan by press time, and Sony may be releasing a U.S. version.

The Box Score is dominated by football games this month. We'll tell you where Madden, Quarterback Club and GameBreaker really stand in this season's football lineup. There's been a lot of talk about each of these games, but hype is sometimes nothing more than that—hype. Take a look inside for the real story.

We also review Andretti Racing, a high-energy title which is brought to you courtesy of the three Andrettis and EA Sports. This is more than just another racing game, so look inside for more info.

The world of sports gaming is constantly changing, evolving and redefining itself. You can count on us at Team EGM to keep you up to date on the latest and hottest news as soon as it comes our way.

THE LINEUP

- **PREVIEWS**
 - POWER MOVE PRO WRESTLING
 - TEN PIN ALLEY
 - NHL HOCKEY '97
 - COOLBOARDERS
 - WAVERACE 64
- **BOX SCORE**
 - MADDEN '97 (PLAYSTATION)
 - NCAA GAMEBREAKER (PLAYSTATION)
 - NFL QB CLUB '97 (SATURN)
 - ANDRETTI RACING (PLAYSTATION)
- **INTERVIEW**
 - MADDEN TELLS ALL TO TEAM EGM

QUICK SPOTS



Madden '97 is coming for the Sega Saturn from EA Sports.



Namco's PS World Stadium X is now on the Japanese market.



EA Sports is getting ready to tee it up with PGA Tour '97.



Natsume is preparing to go up through the gears with Highway 2000 for the Sony PlayStation.

Power Move Pro Wrestling



Move Pro Wrestling.

Although "realistic pro wrestling" may sound like a contradiction in terms, the developers of Toukon Retsuden have worked to make this title as lifelike as possible. The game features 12 different polygon-based wrestlers represented in full 3-D. Each wrestler has his own unique special moves, many of which can do extensive damage. As the match progresses, the wrestlers show fatigue by weaving unsteadily and gasping for breath, and Activision reports that the U.S. version will feature cumulative body damage that will indicate the status of your wrestler.

This is a helpful feature since there are no health bars on screen; watching your wrestler closely is the only way to know how much fight he has left in him. Although you will not have health bars, your wrestler will have "hit points" in two categories: strength and submission. Straightforward moves like kicks and Body Slams will deplete your opponent's strength points, while "submission" moves like the Sleeper Hold and the Camel Clutch will take away his submission points, until he finally gives up.

There are a variety of moves specific to the position of the two wrestlers, as well. For example, certain moves can be performed only when facing an opponent who is unsteady on his feet; others work only when your wrestler is standing directly behind the opponent. If he's face up on the mat, you'll also be able to perform different moves than you will if he's face down.

In order to translate this game for the U.S. market, Activision will be changing the name and appearance of each of the wrestlers, rings

and arenas. Other than that, however, this game is expected to remain intact from the Japanese version. With the popularity of wrestling leagues like the WCW and the WWF, Power Move Pro Wrestling should prove just as successful.



Wrestling as real as it gets

The developers are including a full repertoire of pro wrestling moves, like Pile Drivers, Body Slams, Rope Tosses and even the formidable Figure-Four Leg Lock, a particularly satisfying move that allows you to watch your opponent writhe in pain on the mat. In addition, certain positions in the ring will allow you to perform certain moves. For example, if you're near the ropes, you'll be able to toss your opponent out of the ring, vault over the top rope to stomp on his face then continue the fight on the floor. You'll have the option of bashing his face into the ring barrier or pummeling him until he's out cold long enough to be disqualified. But be careful—if you're out of the ring for too long, you'll run the risk of being disqualified yourself. This game will be so detailed, it will even let you drag your opponent around the ring, by his hair or his feet, or even roll him under the ropes and out of the ring if he's down long enough.



Few sports match professional wrestling for pure enjoyment.

There's nothing quite like seeing two or more grown men throwing each other around, smashing each other's faces into the ground and generally beating the snot out of each other—knowing all the while that somehow no one is going to get killed, mutilated or maimed for life. Although some may see pro wrestling as the quintessential U.S. pastime, it is a sport that is enjoyed worldwide, as evidenced by the success of Tom's Toukon Retsuden—New Japan Pro Wrestling. Soon Activision will be bringing this well-known Japanese wrestling game to America with the release of Power

RELEASE DATE	DIFFICULTY	
November	Moderate	
PUBLISHER	SIZE	
Activision	CD-ROM	
PLAYERS	THEME	% DONE
1 or 2	Wrestling	90%



You have to break a hold if your opponent reaches the ropes.

Japan's Toukon Retsuden gets an American face lift

FACE to FACE

with **JOHN MADDEN**
by Todd Mowatt and Joe Rybicki

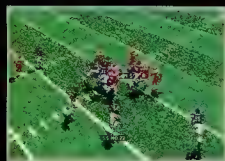
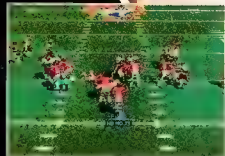

Madden NFL '97

John Madden is a name that has become synonymous with quality football gaming. Since the release of the first Madden Football for the 16-Bit systems, John Madden and EA Sports have worked together to produce in-depth and ultrarealistic football titles that have repeatedly set new standards for other games to follow. The release of Madden '97 for the 32-Bit systems is certain to revolutionize the video football industry once again.

Of course, Madden was a coach long before he was a game designer, and he continues to be one of the most knowledgeable football commentators in the business. It is his years of real NFL experience that makes it happen, and this is what has consistently set his football games a step above the competition. We spoke to Mr. Madden at the Electronic Entertainment Expo in May, and heard his thoughts on the game of football—both at home and on the field.

Team EGM: Which teams are looking good?

John Madden: I think the same teams that looked good last year. You know, the NFC's easy; I still think it's the Cowboys, the 49ers and Green Bay. The AFC, they're all kind of right in the middle. So I think those are the three best teams, and they're all in the NFC.

How do you think the Cowboys are going to do this year, with some of the problems they've been having?

They're going to be good. The problems will be done by the time the season starts. As long as they have Troy Aikman and Michael Irvin, with Emmitt Smith running the ball, and that big offensive line, Charles Haley on defense, Deion Sanders...it's a league of stars, and they've got the best stars.

Do you think Deion is going to ruin the Cowboys with his high salary?

No, no...that's what you have to have; you have to have stars. I mean, the teams that have the best players are the teams that win the Super Bowl. It may be a coincidence, but the place where Deion Sanders has been the last couple of years has been the team that's won the Super Bowl. So I think he may be worth it.

What did you think about the outcome of last year's Super Bowl?

I thought it was a good game. I know both teams, and they didn't play their best football. But the fact that neither team played their best football, I think, made for a good game. I mean, the Cowboys are better than that, and the Steelers are better than that. But neither one of them played well.

Is FOX broadcasting the Super Bowl?

Yeah. I'm looking forward to it. It's in New Orleans this year and that's a great city...a great place for a party.

What college players coming up do you think are really going to make an impact on the game?

I don't know; most rookies, unless they're a running back or maybe a wide receiver, have a tough time making an impact the first year. So if anyone's going to, it's going to be a wide receiver or a running back. Quarterbacks don't even play; there wasn't even one drafted. For offensive and defensive linemen, it takes awhile. Defensive backs, maybe some of them play...but I think if there's going to be an impact player, it'll be a wide receiver or a running back.

In terms of the replication of the game of football through your EA Sports games, how close do the games come, in your opinion, to the actual game of football?

As close as you can come. That's the whole goal of it, to get it where it *is* the game, where it's the same thing. And whatever happens in football, we put in the game. And any tendency, any new rule, any new formation, any new defense, anything that happens in the NFL, we put it in our football game—I make sure of that. So, I don't think you can get any closer to real football than what we have. ★

COORS FIELD.[®]
 THE WIND IS BLOWING
 OUT TO LEFT,
 AND YOUR BUDDY'S
 HANGING CURVE LOOKS
 ABOUT THIS BIG.



Grapefruit. Just hanging there for you to swat like a big round piñata. You might not get this chance again. After all, it's Coors Field[®], where the air is your friend. And who knows, your next game will probably be at Tiger Stadium[®], where the outfield is so deep you have to change area codes to call back to the bullpen. In fact, World Series Baseball™ II has all 28 Major League™ ballparks, replicated in 3-D detail so accurate you can practically see the peanut shells in general admission. Not to mention all the teams, players, rosters, stats, ratings – heck, even



their photos as they're announced at the plate.

It's all here. Along with five different ballpark perspectives, off-the-bat

camera angles, CD stereo sound. You know, icing on the cake stuff that makes World Series Baseball™ II so real, you expect to see commercials between innings. But you won't. Thank goodness.

For more info, visit
 Sega's web site at
<http://www.sega.com>
 or on Compuserve at
 GO SEGA.



World Series Baseball™ II. Also available on Genesis as World Series Baseball™ '96



Sega is registered in the U.S. Patent and Trademark Office. Sega Genesis, Sega Saturn and Sega Sports are trademarks of SEGA. The World Series is a trademark owned by Major League Baseball and may not be reproduced without written consent. Major League Baseball trademarks and copyrights are used with permission of Major League Baseball Properties, Inc. MLBPA, aka CHALBPA NGA. Officially licensed by the Major League Baseball Players Association. ©1996 SEGA, P.O. Box 9039, Redwood City, CA 94063. All rights reserved. Be sure to visit MLBS Official Web Site: [MLB.com](http://mlb.com) www.mlb.com

U.S. 1-900-200-SEGA \$ 85/min. (recorded)
 \$1.05 /min. (ext.) Must be 18 or have parental
 permission. TDD Phone required. Sega of
 America/Canada 1-900-451-3002. US \$1.20/min. (recorded/line)



SEGA SATURN

MADDEN NFL '97 STRATEGY



John Madden brings some of his years of coaching and football knowledge to Madden NFL '97.

POSITION YOUR RECEIVER



Sometimes you will need to maneuver your receiver into a better position to catch the ball. Drop back and get in front of the defender for your best chance at catching the ball. Unless you are several steps ahead of your defender, this should prove to be useful.

OFFENSIVE TACTICS

FAKE FIELD GOALS



Choose the fake field goal as an alternative to a two-point conversion. After the ball is hiked, take off for the sidelines then turn it up field into the end zone. This play is almost always certain to work against the computer.

TAKE IT UP THE MIDDLE

Under I-Formations, choose either of the FB Belly plays to give you positive yardage on a regular basis. Alternating between the two should consistently keep moving the ball. Audible out of this play if the defense brings in a middle linebacker. If the middle looks bad, just bounce around to the outside.



DEFENSIVE TACTICS

LINE STUNTS

Choosing one of the line stunts is the best choice for penetrating the offensive line. Plays such as the two on the left bring the linemen in on an angle, breaking down the offense better than just pushing the line straight back.



PRECISION TACKLING



Timing your tackles is very important for a successful game. Wait until you are on top of the ball carrier before you try to tackle him. This will insure that you don't miss and give up yardage.

TOUGH-PASS COVERAGE



Bring your defender in front of the receiver for the best shot breaking up the play. Watch the bumping when you are trying to get into position or you will get a pass interference call.



TEN PIN ALLEY

American Softworks Corporation is planning to bring bowling action to the PC and the PlayStation with this fall's release of *Ten Pin Alley*. Developed with the cooperation of the Bowling Hall of Fame and Museum, this game gives players the opportunity to bowl in different eras, including the '50s, the '90s and even the lanes of the future, complete with new rules and scoring. ASC is looking to re-create the experience of bowling as accurately as possible, with realistic sound effects, precise ball and pin physics and true-to-life lane

conditions that affect the behavior of the ball.

Players will be able to choose from a number of different characters, each with his or her own strengths and weaknesses. You'll also be able to choose both right- and left-handed players, since positioning changes depending on which hand is holding the ball. You can even select hair color, skin color and wardrobe.

Players begin the frame by aiming the ball then positioning the bowler on the lane. As the character approaches the line, the player chooses the strength of the throw, the release point and how much spin is put on the ball. You'll be able to hook the ball smoothly between the head pins, or hammer it down the middle and hope for a lucky pin bounce. The behavior of the pins will be physically exact, with



Accurate to the last pin drop



the player chooses the ball will have a greater or less effect depending on how hard the ball is thrown. In addition, if the ball is released too late—causing it to bounce—the spin will be even more pronounced, just like in real life. The sound effects and graphics will be dead-on, as well, from the sound of the ball first hitting the lane to the last pin raking the fall. You'll even hear the ball returning during your next shot.

With the intensity of the computations involved in every frame of *Ten Pin Alley*, players can expect a high degree of realism. This is sure to be as accurate a simulation of real bowling as is presently possible. For example, the degree of spin that

ASC is pinning their hopes on bowling



the spinning and bouncing found in the actual game. Pins will even be able to "walk" from their position if they rock hard enough. This means that you'll be able to experience the frustration of watching your last pin rock back and forth without going down.

In-depth options will let players customize the game, dictating factors like scoring method, gutter setup and lane conditions. The game will be further enhanced by entertaining animations that reflect the characters' performance. For example, nail a strike and your character might do a little dance; miss it by one pin and he might throw a tantrum. There will also be animations for when your character releases the ball too early or too late.

ASC tells us that over 20 percent of the U.S. population have bowled at least once. If this statistic is accurate, it's surprising that we don't see more bowling games on the market. Perhaps this is because the game relies so heavily upon real-world physics that it is difficult to re-create accurately. According to David Klein, president of ASC, their game performs 1.3 million computations each time

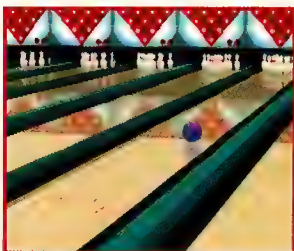

the ball heads down the lane. This makes a simulation hard to pull off well, and this may be the reason why we've seen relatively few bowling simulations. Nevertheless, from what we've seen, *Ten Pin Alley* is certain to live up to the expectations of eager bowling fans everywhere.

RELEASE DATE	DIFFICULTY	
1st Qtr. '97	Moderate	
PUBLISHER	SIZE	
American Softworks	CD-ROM	
PLAYERS	THEME	% DONE
1 or 2	Bowling	75%

F1 Challenge



FOR YOU, THE HELMET IS OPTIONAL.



The most realistic racing experience yet for the Sega Saturn. Amazing 3-D graphics and tight control for gameplay so intense you can almost feel your head rattle.

MONTECARLO



SELECT COURSE

Six action-packed tracks including Monte Carlo, Suzuka and Hockenheim and five top authentic Formula-1 racing teams featuring Ferrari, Benetton, and Williams.



Customizable player settings for greater control of your car's performance including mid-race pit row changes.



"This new racing sim sets the pace for the rest of the field... The game's 3-D graphics match or surpass Sega's previous racing titles..."

- CYBER SPORTS

DISTRIBUTED EXCLUSIVELY BY



INTERACTIVE ENTERTAINMENT



SEGA SATURN



RACE OVER TO V.I.E.'S WEB SITE

www.vio.com

SEGA Saturn and F1 Challenge are trademarks of SEGA. Licensed by FOCA to F1 Television. ©SEGA Enterprises, Ltd. 1995. All rights reserved. Virgin is a registered trademark of Virgin Enterprises, Ltd.

NHL '97

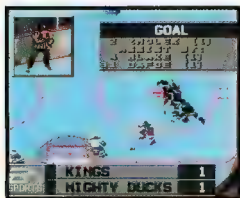
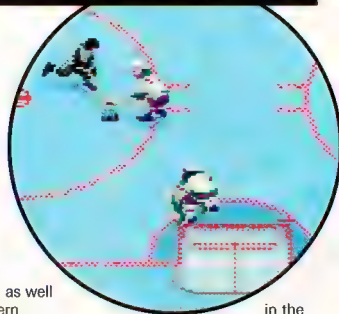

For six years now, EA Sports has reigned in the world of video hockey. No other title has come close to the success of their NHL franchise for the PC and console systems. Now they're setting up to release the newest update in the EA Sports legacy—NHL '97 for the Sega Genesis.



NHL '97 lets you re-create the moves of your favorite players.

Although this game doesn't appear to differ much visually from earlier versions, NHL '97 will include all the action that made the NHL series so popular, and will also have a host of features new to this latest version. For example, players will now be able to perform signature moves from the NHL's star players, like Fedorov, Forsberg and Messier.

The game also includes national teams from Canada,

America and Europe, as well as Eastern and Western Conference All-Star teams, which offer an extended league. You'll be able to build your own top team by trading and releasing players and signing free agents. You can put yourself in the game with the Create-A-Player Option.

Also new to this version is the inclusion of the All-Star Skills Competition, which will offer players the chance to test their abilities in categories like Rapid Fire, Puck Blast, Puck Handling and Shooting Accuracy. You'll be able to take control of the goalie

in the overall look of the game from previous versions, NHL '97 should offer up a challenge to diehard hockey aficionados—although fighting is noticeably absent.

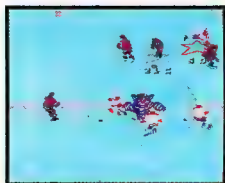

EA Sports continues its NHL legacy

during the Rapid Fire competition and do your best to fend off 30 high-speed shots from the opposition in the Rapid Fire. Or, if you wish, you can streak down the ice to try to slam the puck down the opposing team's goalie's throat in the Puck Blast. The game also includes a 3-on-3 Practice Mode that lets new players get the hang of the somewhat unique controls.

On the competitive side of things, NHL '97 will let you play a tournament with up to 16 different players. You'll also be able to set up fully customized playoffs between whichever teams you choose. Up to four seasons can be played simultaneously, and the game will maintain all-time user records, keeping track of statistics of the best players.

Although it's true that there have been only a few changes

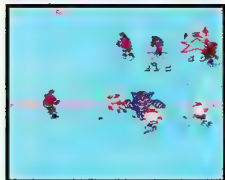

Design your own team

NHL '97 will feature many different team management options. You'll be able to put together your idea of the ultimate team by releasing players, signing free agents and making trades. You'll be able to create players and assign them a series of attributes to augment your team.

TEAM ROSTER



DETROIT

PLAYER

START-EXIT
C-GOALIE/PLAYER
74-SCROLL PLAYERS
A-CHANGE TEAMS

STATUS

2	VIACHESLAV FEDOROV	LD	BENCH
5	NIKLAS CUSTYNER	LD	BENCH
15	MIKE RAWSEY	LD	BENCH
27	MARC BERGEMAN	LD	BENCH
34	ANDERS ERICSSON	LD	BENCH
3	BOB ROUSE	RD	BENCH
18	VLADIMIR KOSTANTINOV	RD	ICE
27	PAUL COFFEY	RD	ICE
13	VIACHESLAV KOZLOV	LW	BENCH

RELEASE DATE

September

DIFFICULTY

Variable

PUBLISHER

EA Sports

SIZE

16-Meg

PLAYERS

1-4

THEME

Hockey

% DONE

100%

COOLBOARDERS

Some people call it a lifestyle. Others call it insanity. No matter what you call it, hurtling down a slope at incredible speeds with nothing but a flimsy fiberglass board to keep you on course is certainly a unique experience. You take your life into your hands with every bone-wrenching drop, and some might wonder whether the rewards are worth it. But that's snowboarding, and it's grown increasingly popular worldwide over the past few

years. Until now, no home video game has really capitalized on the snowboarding market. That's about to change: enter Coolboarders, the new title from Japan's UEP Systems, which is setting up to take over the snowboard niche in a big way. Snowboarding is huge in Japan, and Sony Computer Entertainment officials are seriously considering bringing out Coolboarders over here—with a few



Sony gets ready to catch some big air

years. Until now, no home video game has really capitalized on the snowboarding market. That's about to change: enter Coolboarders,

cosmetic changes and possibly a name change. This game will feature four different courses which will offer a variety of obstacles, like jumps, cliffs, moguls, trees and even some huge boulders that you'll need to slalom your way through. You'll be competing in a timed race, but you'll also score points for pulling off one of the ton of different tricks available to you, like the Stale Fish, the Late 180 and the

Melancholy Grab. It's unclear whether the time or the points will be the factor which decides who wins the race, but it's certain that both will be important. It looks like you'll be able to select your own gear, as well, which is sure to add personality to the game. When you win you should be given points that will allow you to upgrade to a newer snowboard.

The contestants will be presented as fully 3-D texture-mapped polygons, which should allow for realistic, fluid animation. The backgrounds look vivid and should complement the foreground action well.

Although it's still early in the development, it looks like this game will capture the feel of the snowboarding experience. Fans of the sport should keep an eye out for this one.

RELEASE DATE	DIFFICULTY	
December	N/A	
PUBLISHER	SIZE	
Sony	CD-ROM	
PLAYERS	THEME	% DONE
1	Racing	N/A



Show off on the slopes and score big

Coolboarders will give players the chance to live out their snowboarding fantasies on a number of treacherous downhill courses. The courses will feature a load of jumps and obstacles which will give you a chance to show off your talents. If you nail a trick, you'll be awarded points, which will probably be used to upgrade your gear, letting you purchase new boards and accessories.



TECMO® SUP



NTSC U/C

PlayStation 2



KIDS TO ADULTS



CONTENT RATED BY ESRB



TEAM NAMES, LOGOS, UNIFORMS, LOGOS AND OTHER ITEMS ARE TRADEMARKS OF THE LEAGUE INDICATED. SUPER BOWL™, THE BOWL™ AND THE VFL™ ARE REGISTERED TRADEMARKS OF THE NATIONAL FOOTBALL LEAGUE. ©1998 SFLP

TECMO®

TECMO® SUPER BOWL™
RESERVATION/DEPOSIT FORM:

Dear Retailer:

The customer whose name and address is listed below wishes to place a non-refundable deposit on Tecmo Super Bowl. Please contact your local game distributor and/or your central buying office for specific instructions.

Name _____ Amount of Deposit \$ _____
Address _____ Store Stamp or Receipt _____
City _____ State _____ Zip _____
Phone Number _____

Reserve me _____ copy(s) for the Sony PlayStation™

TECMO®

© Tecmo, Ltd. 1998. TECMO® is a registered trademark of Tecmo, Inc. Licensed by Sony Computer Entertainment America for use with the PlayStation game console. PlayStation and the PlayStation logo are trademarks of Sony Computer Entertainment Inc. This product has not yet been rated by the Entertainment Rating Software Board. For information about the ESRB ratings, please contact the ESRB at 1-800-771-ESRB.

Tecmo, Inc. • 19260 South Van Ness Avenue, Torrance, CA 90501

Phone (310) 787-2900

Fax (310) 787-3131

ER BOWL

NOW ON SALE!

\$59.99
OR LESS

TECMO
SUPER BOWL
NFL FOOTBALL
GAME INFO
©1996 TECMO LTD.

IT'S UN-BOWL-IEVABLE!

- SUPER REFINED POLYGON GRAPHICS
- INSTANT REPLAY
- LIVE COMMENTARY
- 3 DIFFERENT PLAYING PERSPECTIVES
- VARIABLE WEATHER CONDITIONS
- UNLIMITED PLAYER TRADES
- NEW PLAY BOOK SYSTEM AND NEW PLAYS
- UPDATED PLAYERS AND STATS
- NEW CROWD NOISES
- FREE EDIT: CREATE YOUR OWN DREAM TEAM
- FREE POSITIONS: PLACE ANY ONE ANYWHERE, ANY TIME
- NEW TOURNAMENT MODE FOR YOU AND 7 OF YOUR CLOSEST FRIENDS

Visit Tecmo Interactive at:
<http://www.tecmo.co.jp>



WAVERACE

Imagine the excitement of motocross racing, with all the jumps, spills and hairpin turns. Now take that race and put it on the water. That's the kind of experience found in jet ski racing, and although they might plague boaters everywhere, jet skis offer a thrill that can't be found in any other sport. Nintendo is getting ready to bring this experience into your living room with the release of Waverace 64 for the Nintendo 64. Although this game was originally planned as a speedboat racer, the developers have scrapped those vehicles in favor of the smaller, lighter and more



maneuverable jet skis. Regardless of the vehicle used, this is expected to be a game completely unlike any other racing title on the market.

The addition of water physics should make for a very unusual experience. Players will be forced to take into consideration the wakes of their opponents, which can be a critical factor in the craft's performance. It will also be necessary

Racing goes to new depths



to leave a lot more room for course corrections and direction changes, since watercrafts are much slower to respond than land-based vehicles. The controls will be simple: A single button will be used for the throttle, and the control stick will be used to steer. Nevertheless, the controls are expected to be challenging, since the vehicles will be controlled more by leaning than by conventional steering. This means that it will be possible to execute a quick 180 by leaning hard to one side and opening up the throttle. Of course, if you don't get the speed right, leaning over like that will send you swimming.

You'll also be forced to contend with weather conditions, like wind and waves, and although flying off a six-foot high wave on a roaring jet ski may sound exhilarating, the landings tend to hurt. Since the races will be set on lakes or oceans, there will be plenty of opportunity for some serious weather.

Racing is not expected to be the only mode available, however. The developers are also talking about an Attack Mode and a Stunt Mode, which should offer even more excitement. There will be fixed

jumps, as well as variable wave sizes, that will influence your performance on each of these levels. Two-player competition will be supported on a split screen, which should give this game the real-life competitive element that contributes to the longevity of some of the best titles.

As one of the relatively few games being developed for the N64, Waverace is certain to draw a lot of attention. With its simple controls and straightforward gameplay, however, it may be viewed by some as too shallow. Then again, some of the best games of all time have been some of the simplest. The verdict? It remains to be seen how well this title stands up in the Nintendo 64 lineup.

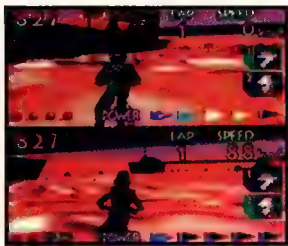

Watch those waves



Waverace 64 will offer different stunt courses which will give you the chance to take your jet ski hurtling through the air with a bunch of different spins and tricks at your disposal. You'll need to keep in mind the surface here; racing on the water is

meaningful (ok, losing isn't). The severely decreased friction coefficient means that you'll need to leave a lot more room for turns and stops. You'll also need to keep an eye on your opponents, since the waves made by their vehicles can send you bouncing and spinning off course. This should prove to be a great deal of fun in the split-screen two-player Mode, where you'll be able to take your friends out of the race for good.



RELEASE DATE	DIFFICULTY	
November	N/A	
PUBLISHER	SIZE	
Nintendo	64-Meg	
PLAYERS	THEME	% DONE
1 or 2	Racing	N/A



KONAMI
XXL
SPORTS SERIES™



IT'S A WHOLE NEW BALLGAME IN THE BOTTOM OF THE 9TH.

**FLUID 3-D
POLYGON ACTION**
STADIUM ANNOUNCER
**700 MLBPA
PLAYERS**
MEMORY BACKUP



SIGNATURE MOVES
TRADES
**FULL SEASON
AND PLAYOFF MODES**
**VOCAL UMP'S
ERRORS**



www.konami.com

©1996 Konami. Konami, the PlayStation™ and the PlayStation™ logos are trademarks of Sony Computer Entertainment, Inc. Sega Saturn™ is a trademark of Sega Enterprises. BOTTOM OF THE 9TH is a trademark of Konami Co., Ltd.



**NOW FOR THE
SEGA SATURN**



**3-D INTUITIVE
BATTING SYSTEM**
TRAINING MODE
WIND CONDITIONS
**"PLAY-BY-PLAY"
ANNOUNCER**
PLAYER STATS



"BOTTOM OF THE 9TH"™



Sporting Game Reviews

Current Favorites:

Todd Mowatt

• Madden NFL '97 • GameBreaker

Dindo Perez

• Madden NFL '97 • DecAthlete

NFL MADDEN '97 • PLAYSTATION • EA SPORTS

Todd Mowatt

EA Sports sat out the season last year. Now they are lining up at the line of scrimmage with a balanced offensive and defensive arsenal. The feel of Madden is incredible and is very easy to get into. Madden should school the competition with good graphics and great gameplay. There are no hidden teams in the game—the best teams of the past can be accessed right from the start. This game has overcome its first big test. Next up, GameDay '97.



This game was well worth the wait; this new PS installment is better than ever. Now you have all of your favorite teams in one CD with no hidden codes to find like in previous Genesis versions. The gameplay is incredible and is a big part of what makes this game so good. The precision player movements and actual football formations will make this year's Madden stand head and shoulders above the rest. The graphics and sound are awesome.

Dindo Perez

NFL QB CLUB '97 • PLAYSTATION • ACCLAIM

Todd Mowatt

Acclaim went back to the drawing board after last year's versions of QB Club. They motion-captured actual NFL quarterbacks and worked on the gameplay. The graphics are vastly improved, although the artificial intelligence is still too easy to beat and beat big. The game is more fun to play as a two-player game. But the true test of any sports simulation is how much fun the game is to play when you play against the computer.



I'm really sorry to say that I am disappointed. I had high hopes for this game, but the moment I sat down and started playing, I noticed something: For a 32-Bit game, I expected better graphics. Characters are pixilated and the action is slow and choppy. Running on the field is quite unrealistic. Other features such as trades and full realistic rosters do some justice, but NFL QB Club does need a face-lift in some areas.

Dindo Perez

NCAA GAMEBREAKER • PLAYSTATION • SONY INTERACTIVE SPORTS

Todd Mowatt

Sony is stepping at the line of scrimmage and has delivered a great college football gaming experience. There are a good number of plays and a countless number of options. This is one game that will be played in every college dorm in the country. The speed of the game is incredible, although the size of the player animations could have and should have been a little bit bigger. This one is in the running for gaming's Heisman trophy.

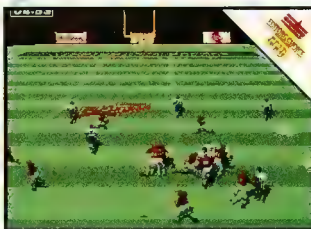

Sony has promised to bring you the best college football game and NCAA GameBreaker proves to be the one. In addition to all of the teams in Division 1A, you have all of the best gamebreakers from each team. The game is a bit fast even on Normal Mode, but the fast action sets the tone as you blow by defenders or receive bone-crushin' tackles. Up to eight players can go head to head and that's just part of the reason this game is a blast.

Dindo Perez

ANDRETTI RACING • PLAYSTATION • EA SPORTS

Todd Mowatt

EA Sports is firing on all cylinders. They have tweaked the engine of this game just right. It's not Ridge Racer Revolution, but it doesn't try to be. It's a very well done Indy Car racing experience. Plenty of tracks and a good number of big-time racing features will have you trying to improve your lap times, win the points championship, and go for the checkered flag well into the night. The fact that this game is four-player compatible is fantastic.



NASCAR and Indy in one game. What else can you ask for? Andretti Racing tries to mimic what you've seen in any NASCAR or Indy racing game, and it comes very close. Smooth animations, great graphics and easy controls are just a few features that make Andretti Racing an accurate racer. The best feature that certainly changes the gameplay is the link capability. You're able to play up to four players head-to-head. This game is fun to play.

Dindo Perez

BRUTAL ACTION. NOT BRUTAL ACTING.

POWER MOVE PRO WRESTLING™

Authentic wrestling moves. Extreme wrestling punishment. Delivered in real 3-D mayhem.



Pile-drive your opponent in incredibly motion-captured 3-D graphics!



Body-slam your adversary and perform over 50 other authentic wrestling moves!



Flying-kick your opponent with awesome true-to-life wrestling action!

Executing a flying kneedrop into your face next month. Available on Sony PlayStation®
Get your neck broken or your back cracked at <http://www.activision.com>.

ACTIVISION



THE TOP DEFENSIVE PLAYER
IN HIGH SCHOOL

THE BEST END
AVAILABLE FOR
RECRUITMENT



YOU'RE THE COACH!

YOU'RE THE ATHLETIC DIRECTOR!

YOU'RE RESPONSIBLE FOR RECRUITING
AND BUILDING THE NEXT NATIONAL
CHAMPIONSHIP TEAM!

BECOME NATIONAL CHAMPIONS

WITH

**mvp College
Football
'97™**



IT'S GOT ALL 111 DIVISION 1A TEAM PLAYBOOKS!

BUILD A NATIONAL CHAMPION!

This is no ordinary football game. MVP College Football '97™ has every Division 1A school—111 in all! Each team is accurately represented on both sides of the ball. You take the role of player, coach and athletic director—hire coaches, set your game-plan each week, recruit top high-school talent, and build a national champion team from the ground up. Users earn skill points during the season that can be used to improve players, hire high-prestige coaches, or improve training facilities. Season statistics and league leaders are tracked for each season. Use the **Replay** to check out or view the best plays and hardest hits.



REAL FOOTBALL HITTING!

It's the hardest hitting football game to date. All of the physics of football—precisely, tackles and collisions—have been painstakingly researched.

MVP College Football '97 has special Collision Zones to determine the outcome of hits. Direction of movement, the colliding players will dictate



momentum, and the skills and attributes the outcome of every tackle.

111 TEAMS, 111 PLAYBOOKS!

Comprehensive playbooks were designed with the help of Tom Walsh, former offensive coordinator of the Oakland Raiders and current CBS Radio college-football broadcaster. Each team runs the actual offense and defense of their real-life counterpart. You'll use detailed individual playbooks—after all, why have 111 teams if everyone uses the same playbook?



IS IT TELEVISION OR A VIDEO GAME?

There have never been player animations as realistic as in MVP College Football '97! Hundreds of hours of motion-captured data has been used in creating the most life-like characters to ever run across a video game field. Details of architecture, sky, and crowds create the feeling of sitting in the bleachers.



For more information, reach us on the WorldWide Web at <http://www.dataeast.com>, or www.mvpsports.com or online at CompuServe (see number below), or call our tipline at 1-900-454-5435. (\$9.95 first minute, \$7.75 thereafter/18 years or older/touch-tone phone required).

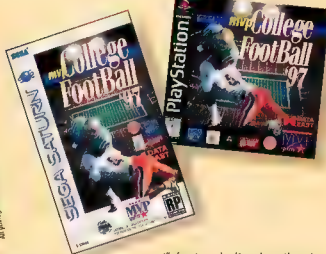

All information may be subject to change without notice.

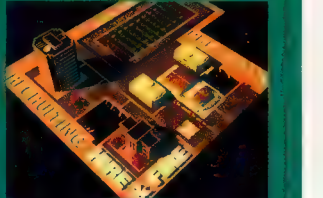
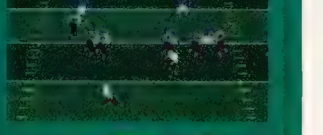

mvp College Football '97



MVP College Football '97™ is a trademark of Data East USA, Inc. Data East MVP Sports is a registered trademark of Data East USA, Inc. 1996 all rights reserved. BlazStry is a trademark of BlazStry Software. The "Officially Licensed College Products Label" is the exclusive property of The Collegiate Licensed Company. The Collegiate Licensed Product is the property of the Independent Licensing Group. Sega and Sega Sports are trademarks of SEGA ENTERPRISES, LTD. PlayStation, the PlayStation logo and the PS logo are trademarks of Sony Computer Entertainment America.

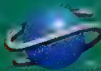

GET CONNECTED

NUKE™

www.nuke.com.

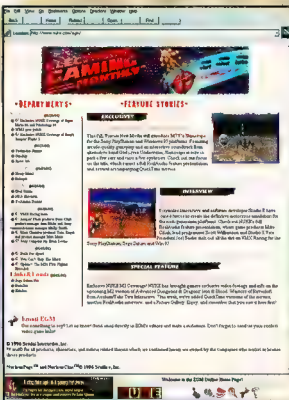

Interface gives you the chance to praise, gripe, ask, speculate or simply reflect. *EGM's* editors will discuss some of today's top issues in the video game industry. In addition, a prize will be awarded to the writer of the best letter submitted for the month (please make sure you enclose your mailing address).

You can reach the editors of *EGM* by writing to:

Interface, Letters to the Editor
1920 Highland Avenue, #222
Lombard, IL 60148

You can also e-mail the editors at 75052.1667@compuserve.com. *EGM* reserves the right to edit all correspondence for space.

Don't forget to check out *EGM's* articles, exclusive reviews and more on the World Wide Web via the *NUKE* home page at www.nuke.com.

Letter of the MONTH

OPEN LETTER TO THE INDUSTRY'S BIG SHOTS

Dear *EGM*,

Well here goes...an open letter to the game industry's "big players." **MATSUSHITA**-So you want M2 to be everywhere, eh? You want to incorporate it in DVD players? You want to license the technology to the PC industry? TVs? The Internet? What you do not realize is that a feat like that would take years. DVD players will not be mainstream for at least five years. By then, the next generation of consoles will arrive. Your problem is that you do not see the game industry as what it is...a game industry! If you license your \$100 million technology to other companies with no desire to be involved in the games industry, you will fail as a video game name.

SEGA-You are my personal favorite, but you have been messing up. Where do you think your Saturn would be today, if you had released a perfect home version of *Daytona*? Look, you are the gods of marketing, but you are also the gods of rushed games. Make sure the next system you make is 100 percent ready, and that no upgrades will be necessary for at least four years. Have at least five awesome games at launch, and you will do better. **SONY**-I will admit that you are a great company, and you have been doing really well. You have not fallen in the trap of trying to create a "dream technology box for every purpose." The only thing I might ask is to not get another console (*PlayStation 2*) out too soon. That will upset gamers. Try to let your console last as long as it can without upgrades, and you will be greatly respected, if not worshiped, by gamers.

NINTENDO-The Nintendo 64 better be what you claim it to be, and it better be out by Sept. 30, as you promised. I realize that games take time to make, as do consoles, but it better rock because Sony is a hard company to battle. I like the bulky drive concept. In essence, you have a format capable of everything a CD-ROM is capable of, minus the FMV

(and that's great...FMV sucks anyway). Just make sure the bulky drive is not too expensive. You better get it out before time runs out on your carts. Once you get to your cartridges' maximum meg per dollar capacity, the prices per cart will be too high. Be nice to us and avoid that.

Rodney Herrera
via e-mail

Great letter. You make excellent points about making too many upgrades. That's what hurt Sega's reputation with gamers: it upset their consumers when the Sega CD was promised to be the new wave of the future, then shortly after, the 32X, then the Saturn. Today, Sega and Sony have dropped hints on their future 64-Bit-plus systems. They have to be extremely careful, however, in how they are going to let their customers know about them. Should they get people (and stockholders) excited about the future of Sega and Sony? Maybe, but then that would seal thunder away from their "weaker" systems that are out in stores now. By the way, we had to cut out the part of your letter to Bill Gates saying that your computer was perfectly fine until Windows 95 showed up on it. Too bad...we loved it.



Congratulations Mr. Herrera. You win an Acclaim Dual Turbo Joystick. Please send us your address (attn: Dan Hsu) so we can mail you the prize. To everyone else: Please include your address in your correspondence (especially e-mail) if you want to be considered for Letter of the Month!

N64 PACK-INS

Dear EGM,

I have some new information concerning pack-ins for the Japanese N64. At my local games store, I inquired about the price and got a staggering response: over \$500 U.S.! It included two games; PilotWings 64 and Super Mario 64. They were sold as a pack and were non-separable. This seems to be a strange move since only three games are coming out at launch!

Ravi Hiranand
via e-mail

We've heard of a few countries selling gray imported Japanese N64s with packed-in PilotWings 64 and Mario 64 for up to \$900 U.S. All prices set outside of Japan for Japanese systems are on an individual basis, since they are not official Nintendo releases in those countries. If demand is so high that consumers are willing to pay that much, then all the more power to the greedy store owners.

DON'T BE SHY

Dear EGM,

I am writing in response to Charles Shy's letter in the June edition of EGM (#83). First, let's not forget the target audience of game manufacturers: 7- to 18-year-olds. I think that if he is not satisfied with the type of games coming out for the target audience, he should find a new hobby. The game companies should not concentrate on an older audience just because they have the money to pay for more expensive systems and games. If Chuck thinks he is so sophisticated and experienced, then he should remember that even he was 14 once.

James Barclay
Kuwait

You are mostly correct, but a new study by the Interactive Digital Software Association (IDSA) shows that people over the age of 18 are part of a major group that are using entertainment hardware and software. It seems that the older generation matters plenty to the game companies, as they are spending big bucks on video games. Also, Mr. Shy is entitled to an opinion. If he's not satisfied with the games coming out, that does not mean he has to forget about this

hobby. He can voice his grievances and hope things change. We might not all agree with what exactly he wants, but wait...Mr. Shy has something to say...

Dear EGM,

I was surprised to find a previous letter of mine published in Interface. After a thorough review of your reply, I came away greatly enlightened, yet also feeling that you may have missed my point. It's not that I want to put a stop to all of the "cutesy" games being produced, it's just that I feel that the industry is forgetting about the adults that have grown up playing games and who are continuing to play. Sooner or later, the push must be made toward more immersive gaming that will provide more depth and challenge for the older and more experienced gamer that may require it. In conclusion, I feel that if the companies of today are too afraid to step away from their old formulas and start to deliver a few more revolutionary games of a deeper level, then they could be overshadowed by the companies that will.

Charles Shy
Cleveland Heights, OH

Point taken, but your conclusion is a bit over-dramatic. Just as much money is to be made selling simpler games to the younger generation as selling complex games to the older generation. It's doubtful that a successful game company will be overshadowed by ignoring part of a big market. But have patience Mr. Shy. With advances in technology and more 64-Bit systems on the horizon, you'll soon get to see more of what you want.

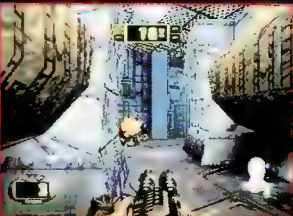

Games like Disruptor (featured in this month's Next Wave section) are designed with older players in mind. The graphics are realistic and some enemies are intelligent.

TOP 5 REASONS SHIGERU MIYAMOTO (THE MAKER OF MARIO GAMES) IS SO DARN CREATIVE

- 5 The new torture chamber built in the basement of Nintendo HQ.
- 4 Late night sake (you know, the wine) "brainstorming" sessions at the office.
- 3 Healthy Nintendo paychecks from deep accounts.
- 2 Three words: magical Mario mushrooms.
- 1 He's simply brilliant (and EGM gives him the utmost respect).

A HAPPY NATION

Dear EGM,

Well, at least we know what all of the Japanese gamers are doing right now: playing their brand-new N64. While in the meantime, we get the shaft (again) and have to suffer a few more months before we get to play. I'm sure you won't have to wait, will you Mr. or Ms. EGM editor who gets to play everything for free! Lucky jerks...anybody wanna trade jobs?

Steve Chaffin
via e-mail

By the time you read this (unless Nintendo shafts, as Mr. Chaffin so eloquently puts it, U.S. players again) you should be playing the N64 in your home. Yes we did get to play it, even before it was released in Japan, and no, we don't want to trade jobs. We don't care what you do, but you can't beat getting paid to play video games day in and day out!

NO MARIO PACK-IN

Dear EGM,

I heard that the N64 may try to better compete with the PlayStation and Saturn by reducing it's price to \$200

(continued on page 184)

IN THE PAGE

(continued from page 183)

and also offering a \$250 system with Mario 64 as a pack-in. Do you know anything more about this?

Jeff Hopman
jhopma97@calvin.edu

It seems that most of our mail lately is on the subject of the Nintendo 64! A representative from Nintendo privately told *EGM* that Mario 64 will probably not be included as a pack-in for a cheaper price. Why? Almost every N64 system buyer is going to buy Mario 64 anyways, like the Japanese consumers are doing. So why offer the two together for a lower price and lose potential income?



Super Mario 64 will be such a hot ticket that Nintendo will milk it for all it's worth.

LINKING THE DUKE

Dear *EGM*,

Do you know if Duke Nukem 3D for the Sony PlayStation will support a link cable?

Eric James
via e-mail

Yeah, we know.

FACING REALITY

Dear *EGM*,

Issue #85 is the best in a long time. I like all the new features. Just a suggestion: Why don't you make the faces of the Review Crew normal so that we can see what they really look like?

Eric Mattes
New York, NY

Thanks for the compliment. We are in the process of bringing back some of the old features our readers have requested and adding new ones we think they'll dig. (Check out the new paper the mag is printed on!) Please

let us know what you think. By the way, what do you mean make the Review Crew faces normal? That's what these freaks really look like.

DON'T BUY VIDEO GAME SYSTEMS???

Dear *EGM*,

Over the past few months, all I've been hearing about is the PlayStation, Saturn and the soon-to-come Nintendo 64. From what I've seen and heard about these systems, I've decided that buying any of them would be a big mistake. Why? Because I have a powerful PC sitting in my basement. Why should I go out and pay \$250 for a system? For the price of one system and maybe a game, I can get six games for my PC which I already own. Why waste the money? By the time the Nintendo 64 gets to America, there will be newer technology—I can play those same types of games for the N64 on my PC. I know for a fact that three-fourths of the population own a PC, so why go out and buy one of these expensive [game] systems? To all the PC owners: Stick with your PC. It's the only logical thing to do.

Dustin Weaver
boyblue@juno.com

We'd like to know how you "know for a fact" that three-fourths of the population owns a PC. First, we assume that you mean households. Otherwise you'd be telling us that three out of four people own a PC. Second, the Software Publishers Association (SPA), who conducts annual studies on this type of stuff, told us that "only" 34 percent of households in the U.S. have a PC (by the way, 29 percent of households have a video game console). When you brought up being able to buy six games for the price of one \$250 gaming system, you failed to realize that a PlayStation owner could buy 40+ games for the price of your \$2,500+ computer system. Of course a computer has many practical uses that a dedicated game console could not perform, and of course, many great games are out for the PC that are not available for home systems. But you are wrong if you think your PC will get to play everything that the systems offer. Good luck trying to find Mario 64 or NIGHTS for Windows 95. And good

luck playing your PC games on your living room couch, on your large-screen TV, with a few of your friends next to you drinking beers, er, sodas and battling it out in Super Bomberman. Let's also not forget about hardware problems. Mr. Conlan's letter describes it perfectly:

Dear *EGM*,

Much like the explosive video game market, computer games are getting better with each passing day. In fact, computers can boast faster gameplay, higher-quality graphics, better sound and faster access speed than any of the systems currently on the market. The question is: When computers have such an edge, why are console machines bought at all? The reason is that computers suffer from a

(continued on page 185)

Top Scariest Games



It's Halloween time, and *EGM* wants to recognize the top five games that may have given us a slight chill at one point or another.

5

Doom

Microsoft/Id Software



4

7th Guest

CD-ROM



3

Legacy of Kain

Microsoft/Genie



2

D

Microsoft/3DO



1

Resident Evil

PlayStation



(continued from page 184)

seemingly incurable plague of upgrade syndrome. When you buy a computer, it's high-tech. A few months down the line, everything is being made for the next model, and you are stuck having to upgrade, be it RAM, [storage] memory, operating system, modem speed, CD-ROM speed or sound card. It costs major bucks.

Richard Conlan
Attleboro, MA

Several years ago, 16-Bit systems debuted. It's guaranteed that games being produced for them today will work on those ancient machines. Several years ago, Intel's 486s were the top of the line. Today, they're too slow to run the newest software; Pentium processors are considered the norm, that is until P-6s are released. So if you have an old computer, what would you have to do to keep up? Spend \$500 on an Overdrive

chip, perhaps \$200 on a new 3-D video card, etc. By the way, after installing all of that, we hope that you won't have any of the compatibility problems PCs are known for.



Can you play four-player Bomberman over a computer network? We don't think so!

Don't mistake us, we love our PCs, but Mr. Weaver's arguments are narrow-minded. A market for dedicated game consoles will always thrive. If you don't like them, then don't get one and leave those of us who do alone.

NO TRUE PSYCHO

Dear EGM,

What happened to the Psycho Letter of the Month?

Andrew Price
Highland, CA

Frankly, those letters just got plain stupid. All the psycho letters lost their originality. The Psycho section became a forum for babbling that was not truly crazy, just mindless and effortless. But we promise you this, if we get a great, original letter once in a while, we'll print it in Interface. Of course, it'll have to touch on the subject of video games!

P.S. to Eric James—We were just teasing you. PlayStation's Duke Nukem 3D will be link compatible.

EGM LETTER ART

Where Creativity, Your Favorite Video Game and A Stamp Can Make You Immortal!

Or at least get your name and work in the magazine and win yourself a great controller (FIRST PRIZE ONLY)



Adam Sturch
Cimarron, NM

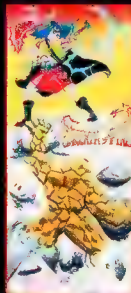

Bill Elder
Belmont, WV



Chad Lachier
Alliance, OH

WINNER!

Dallas Ragon • Naples, Italy



Congratulations, Mr. Ragon (who's actually in the U.S. military and is stationed in Italy). Your prize is on its way—an ASCII Specialized Control Pad for the PlayStation. It features rapid-fire controls for all buttons and slow motion for those intense moments.



Uzzette Landaverde • San Luis, Mexico



The ASCII
Specialized
Control Pad.

ADVERTISER INDEX

Acclaim	746-47, 76-77, 100-01, 122-23, 131
Accolade	139, 147
ACT Laboratories	135
Activision	18-19, 79, 179
American Softworks	111, 113
American Technos	157
ASCII Entertainment	67-69
Bantam America	29
BRE Software	189
C7 International	159
Capcom	49, 196
Crave	188
Crystal Dynamics	8-9
Crystal Rim	133
Data East	180-81
Eidos	88-89
Electronic Arts	30-31, 58-59
Game Express	193
Intercept Accessories	194-95
Interplay	35, 39
Japan Video Games	190
Konami	97, 177
Mindscape	137
Namco	4-5, 104-05
Nintendo	2-3
Playmates	41, 43, 45
Psychosis	63, 64-65, 81, 83, 85, 87
Samsung Electronics	24-25
SCAT Corp.	25
Sega of America	11-13, 52-53, 167, 169
Sony Computer	16-17, 50-51
Tecmo, Inc.	118-19, 174-75
THQ, Inc.	37
Titus Software	151
Tommo, Inc.	191
20th Century Fox	108-09
Ubi Soft	145
Universal Interactive Studios	149
Viacom New Media	99, 129
Video Game Discounts	192
Virgin Interactive Entertainment	171
Williams Entertainment	23, 27, 32-33, 36-37, 70-71, 73, 75, 186
Working Designs	

Another Installment of The

Shining Wisdom Contest

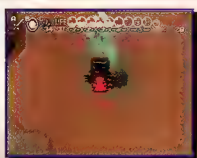
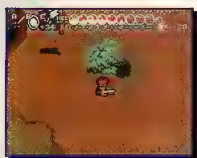

- | | |
|------------------------|----------------------------|
| 1 Dazzle Orb | 5 Life Bubble |
| 2 Record Book | 6 Medicine Bottle |
| 3 Miracle Diary | 7 Medicine Bottle |
| 4 Toydona USA | 8 Life Saver Bubble |

This is a general hint that's going to get you lots of hidden items. With this secret hint, you can boost your life, life stock and, of course, your completion ratio which will bring you closer to \$10,000. To find any of the secrets, simply equip the Blast Orb and any other item and blow it all away.

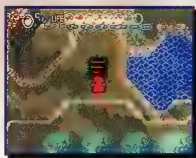
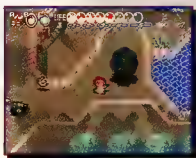

The Blast Orb



The Fire Orb

The Flame Orb is your best bet on this one... Equip it with any item, and you will be able to burn those discolored trees down. Once you have done this, stairs will lead the way to finding some very important secret items. They will help you through the game and could make you \$10,000 richer.

- | | |
|---------------------------|-----------------------|
| 1 Record Book | 5 Angel's Wing |
| 2 Shield Orb | 6 Life Bubble |
| 3 Life Save Bubble | 7 Record Book |
| 4 Record Book | 8 Angel's Wing |

You Could Win \$10,000

1. To enter: Send a legible photograph or a video tape showing the Final Status Summary Screen (as depicted below) from the Sega Saturn® Shining Wisdom for Shining Wisdom Contest to Working Designs, 18135 Clear Creek Road, Redding, CA 96001.

Enter as often as you wish, but only the single fastest time submitted by any one individual will be entered for final consideration. Limit one submission per game package. Duplicate game screens derived from the same save data source submitted by different individuals will be disqualified. Times and finish percentages generated by using software modification codes and/or hardware will be disqualified. Winner may be required to demonstrate skill used to gain winning time in order to claim grand prize. Entries must be received by November 1, 1998. All entries become property of Working Designs, Inc., and will not be acknowledged or returned. Working Designs, Inc. Assumes no responsibility for lost, mutilated, late, ineligible, incomplete, postage due, or misdirected entries. Unclaimed prizes will not be awarded. Limit one prize per family, organization, or household. **Prize:** One (1) Grand Prize: \$10,000. Twenty five (25) First Prizes: One year subscription to Electronic Gaming Monthly (Approximate retail value \$60). One Hundred (100) Turn-in-up prizes: Shining Wisdom Poster (Approximate retail value \$5). Winners will be determined on the basis of the fastest completion time amongst those entries with the highest completion ratio (as reported on the status screen sent as an entry requirement). Judges' decision to be made the week of November 4th, and winner will be notified by November 15th. All judges' decisions are final. Grand prize winner will be notified by Federal Express. Runner-up prize winners will be notified by mail. Results will be published in Electronic Gaming Monthly, as well as on Electronic Boutique's Internet Web page. No substitution of prizes is allowed, except at the discretion of Working Designs, Inc. Should one of the featured prizes become unavailable, a similar contest open to residents of United States and Canada only. Non-compliance with the rules of the contest and/or the return of the prize notification will be grounds for disqualification. In the event of a disqualification, the Grand Prize will be awarded to the next available entry. In the event of a disqualification, First and Runner-up prizes will not be re-assigned. Winners or their legal guardians shall sign an affidavit of eligibility/waiver of liability/prize acceptance within 30 days of receipt of final prize. By acceptance of prize winners agree to the use of their name and/or likeness for purposes of advertising, and/or promotion without further compensation, unless prohibited by law. Employees of Working Designs, Sentai Publishing Group, Inc., SEGA Enterprises, Electronic Boutique and their affiliates are not eligible. Neither Working Designs, Sentai Publishing Group, Inc., SEGA Enterprises, Electronic Boutique are responsible for any damages, losses, or expenses that consumers might incur as a result of this contest or receipt of prize. Winners accepting prize(s) agree that all prize(s) are awarded on the condition that Working Designs, Inc., Ziff-Davis Publishing Company, SEGA Enterprises, Inc., Electronic Boutique and their agents, representatives, and employees will have no liability whatsoever for any injuries, losses or damages of any kind resulting from acceptance, possession, or use of the prize(s). Winner further acknowledges that Working Designs, Inc., nor any of the contest sponsors has neither made nor is in any manner responsible or liable for any warranty, representation or guarantee expressed or implied, in fact or in law, relative to any prize, including but not limited to its quality, mechanical condition, or fitness. **Limit of Winner:** For a list of winners, send a self-addressed stamped envelope to Shining Wisdom Winners of Working Designs, 18135 Clear Creek Road, Redding, CA 96001. Requests for winners must be received by Dec. 15, 1998. Allow four weeks for delivery of winners list. **Restriction:** Void where prohibited or restricted by law. All federal, state and local regulations apply. **Copyright:** This contest is sponsored by Working Designs, Inc., Ziff-Davis Publishing Company, and Electronic Boutique. SEGA Enterprises, Ltd., is not a sponsor. Shining Wisdom is a trademark of SEGA Enterprises, Ltd., licensed by Working Designs, Inc. SEGA Saturn are trademarks of SEGA Enterprises, Ltd. ALL RIGHTS RESERVED. Electronic Gaming Monthly is a trademark of Ziff-Davis Publishing Company. Electronic Boutique is a registered trademark of Electronic Boutique, Inc.

Next Month

EGM²

Tips, Tricks and Strategies from the Gaming Gurus

October 1996

EGM² kicks off an issue of intense fighting action with tons of moves, combos and techniques for the current upswing of fighting games. Also be sure to check out the big three's famous games: NIGHTS, Crash and Mario 64. Inside you'll find the most up-to-date and complete cov-



EGM² gives you comprehensive Mario 64 coverage when you need it most!

erage of these big titles. Also, be sure to get in touch and get your fill in the new Gamers' Forum filled with real info for avid gamers from all walks of life and gaming.



Check out Crash's final, elusive island plus ALL the gems and secret areas!



FEATURE STORY

Look for an exclusive hands-on test of Virtua Fighter 3 and all the new arcade games.



EGM² travels the world to get the latest information on the games that will be hot in 1997!



Fighting Special

EGM² blows out the latest and greatest fighting games. From SF and MK to Tekken 2 and King of Fighters '96.



EGM² takes you through the whole Die Hard trilogy. Look for tips, tricks and strategy on the driving, shooting and platform levels in this gigantic three-in-one game.

ELECTRONIC GAMING MONTHLY

November 1996

The EGM editors are in the air flying to London and Tokyo to gather the latest information from the fall trade shows. Look for an exclusive first-hand walk-through with tons of screen shots and insider info.

Super Mario 64 is the hottest new game this year, and our Tricks editor has been working hard in rounding up a new batch of game-breaking codes to help you through this super cart. Don't miss it!

In Team EGM our editors plan on getting a first look at EA's hot NBA Live '97. Watch for our exclusive preview.

Our Review Crew is already



The Review Crew puts Final Doom to the test. How will it rate?

tearing into Final Doom for the PlayStation. Next issue they'll tell you if it lives up to its reputation, or if gamers should save their cash and wait for Quake. All this and much, much more!

Your #1 Source of American and Japanese Video Games

JAPAN VIDEO GAMES

DEALERS AND WHOLESALERS WELCOME CALL (818) 281-9282 FAX (818) 458-6845 eMail: japanvideo@aol.com

ULTRA 64



IMPORT
Available Now!

Call for price

Cruisin' USA
Blast Dozer
Body Harvest
Buggy Boggie
Kirby's Air Ride
Mission Impossible

Pilot Wings 64
Robo Tech
Shadows of the Empire
Star Fox 64
Super Mario Kart R
Turk Dinosaur Hunter
Waver Racer

SEGA SATURN

Saturn Converter

\$29

with game purchase



Now you can play any Import Saturn Games on your U.S. Saturn System w/ Saturn Converter

(Import)

Albert Odyssey 2
Classmate IF
Dark Savior
Dragon Ball Z
Dragon Force
Dynasty War 2
Enemy Zero
Fatal Fury 3
Fighting Vipers
Gals Panic
Godzilla
Gundam
Keio Geki

King of Fighter 95
Langrissr 3
Lunar Silver Story
Ogre Battle
Outrun/After Burner 2
Policeauts
Real Bout: Fatal Fury
Sailor Moon Super S
Samurai Shodown 3
Star Fighter 3000
Striker 1945

Telms Plus
Thunder Force GLD P
Tokimeki Mahjong
Tokimeki Mini Puzzle
Toshinden Ura
World Hero Perfect



and many more...

(US)

Alone in the Dark
Area 51
Buster Bro. Collection
Die Hard Trilogy
Dragon Force
Dragon's Lair 2
Fighting Vipers
Iron Man
John Madden 97
Legacy of Kain
Marvel Superheroes
NFL Full Contact
Nights
Project Overkill
Spot Goes Hollywood
Street Fighter Alpha 2
Tomb Raiders
Virtua Fighter Kid
World Series Baseball

IMPORT SPECIAL:

King of Fighter 95 \$59
Dragon Ball Z \$59
Rockman X \$59
Ruzzle Bobble 2 \$49
Bomberman \$69
Ninku \$69

Call for any games not listed above

SUPER FAMICOM

Dragon Ball Z
Dragon Ball Z Hyper
Dragon Quest 6
Final Fantasy 5
Fire Emblem
Star Ocean
S. Bomberman 3
Parodius
Romancing Saga 3
S Fire Pro Wrestling Prime

Power Pro Wrestling 96
Lord of Elemental
Sailor Moon RFG
Sailor Moon Super S
Secret Of Mana 3
Super Bomberman 4
Tales of Phantasia
Tengai Makyo Zoro
Treasure of Rudora

SPECIAL OF THE MONTH:

Bahamut Lagoon	\$69	Fire Pro Wrestling X	\$49
Gundam W	\$69	Ranma 1/2 S. Bl.	\$39
Gun Hazard	\$69	Yu Yu Hakusho 2	\$39

NEO GEO / NEO CD

NEO GEO CD

\$339

with any game of your choice

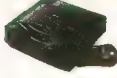

Art of Fighting 3
King of Fighter 95, 96
Metal Slug
Neo Drift Out
Over the Top
Pulstar

Ragnagard
Real Bout: Fatal Fury
Samurai RPG
Samurai Shodown 3
Shin Oh Ken
World Hero Perfect

**** Get \$5 off with purchase of 2nd Neo-Geo CD Title**
Large Selection of Used Neo-Geo Games \$50 or under**

SONY PLAYSTATION



(Import)

4th Avenue V.S.
Robot Wars
All Japan Pro Wrestling
All Japan Pro Wrestling 2
Arc the Lad 2
Burning Fest
Captain Tsubasa J
Cool Boarders
Macross Digital Mission
Dragon Ball Z
Genso Sukkoden
Gundam V, Z, O
King of Boxing
Megatudo 2098
Motor Toon GP 2
Namco Museum 3
Ogre Battle
Over Blood
Persona
Pinball Fantasy DLX
Rockman X3
Sailor Moon Super S
Samurai Shodown 3
Star Fighter 3000
Tenchi Muyou
Telms Plus
Tobal 1
Tokimeki Memorial Puzk
Wild Arms
Zero Divide

(US)

11th Hour
Bubble Bobble
Buster Bros Collection
Crash Bandicoot
Die Hard Trilogy
Dragon's Lair 2
Iron Man
John Madden 97
Jumping Flash 2
King of Fighter 95
Legacy of Kain
Marvel Super Heroes
MLB Pennant Race
NFL Full Contact
NHL Powerplay 96
Project Overkill
Ridge Racer Revolt
Street Fighter Alpha 2
Tekken 2
The Hive
X Men

IMPORT SPECIAL:

Gradius Deluxe \$49
King of Fighter 95 \$69
Namco Museum 2 \$55
Dragon B Z Legend \$69
Gundam #1 \$69
Choro Q \$69

PC ENGINE

Please call for any special order

PC ENGINE

Dragon Ball Z
Cosmic Fantasy 4
Sailor Moon Collection
Record of Loos W 2
Y's 4
Vastel 2
Arcade Card
Advanced V.G.

NEC FX



NEC FX

Battle Heat
Deep Blue Fleet
Far East of Eden
Graduation
Return to Zork
Team Innocent
Zenki
Der Langrissr

3DO

Get 4 Free Games with purchase of 3DO

\$169



\$19 SPECIAL SALES

Battle Sports
Blade Force
Pirates Space
Immercenary
Killing Time
Star Blade
Rise of Robot 2

John Madden
Gridders
Out of This World
Shadow
Soccer Kids
Jurassic Park

IMPORT 3DO GAMES

Yu Yu Hakusho (JPN) \$69 Sailor Moon (JPN) \$69

MEGADRIVE SPECIAL

Sailor Moon \$49 Dragon Ball Z \$49 w/ adaptor

Free Posters or Stickers with purchase of BBZ, Sailor Moon or Ranma Games!

Out of this World Savings!

GAME STAR

C.O.D. & Credit Card OK

Send \$1.00 for delivery of your catalog.

Complete Line of Super Nintendo, Genesis, Game Gear, and Virtua Boy. Check with us before you call anyone else!

For Mail Order or Wholesale CALL (818) 281-9282 or FAX (818) 458-6845 710 W. Los Tornos San Gabriel, California 91776

TO ORDER CALL 818-839-8755

PlayStation
 JAPANESE PLAYSTATION SYSTEM + 2 GAMES
\$299 + GAME & ACTION REPLAY
 Free Action Replay with a purchase of any Sony PlayStation game!!
SPECIAL

SEGA

SEGA SATURN™
 WHITE SATURN™ SYSTEM + 2 GAMES
\$299
 JAPANESE SATURN™

PlayStation
 SOULKNIGHT'S HOLIDAY
 ROBBY DEAD 6
 NINJA BAT
 NFL GAME DAY
 NHL FACE OFF
 ESPN EXT. GAMING
 CAPCOM
 PLAYSTATION 1
 SHOOT OUT
 MARSHALKERS
 HOCTAN

U.S. SATURN™ SYSTEM + 2 GAMES
\$199
U.S. SATURN™ SYSTEM + 2 GAMES + 1 FREE GIFT
\$249

PlayStation
 SOULKNIGHT'S HOLIDAY
 ROBBY DEAD 6
 NINJA BAT
 NFL GAME DAY
 NHL FACE OFF
 ESPN EXT. GAMING
 CAPCOM
 PLAYSTATION 1
 SHOOT OUT
 MARSHALKERS
 HOCTAN

NEO-GEO CDZ
 CDZ SYSTEM & FATAL FURY 3
\$400

MISSION STICK \$39
ARCADE RACER \$39
ACTION REPLAY \$69
 ENTER A CODE AND GET SPECIAL PRIZES WITH ACTION REPLAY!!
 BUY ONE FREE GIFT!!

COME VISIT OUR NEW STORE AT: 1045 E. Valley Blvd. San Gabriel, CA.

SPECIAL
 PLAYSTATION 1
 SHOOT OUT
 MARSHALKERS
 HOCTAN
\$29
\$29
\$59

MOVIE CARD
 NOW YOU CAN WATCH MOVIE ON YOUR SEGA SATURN™
\$179
ARCADE STEERING WHEEL
\$59
 FOR SEGA SATURN™
 JOYSTICK PLAYSTATION™

UNIVERSAL ADAPTOR
 NOW YOU CAN PLAY UNIVERSAL SATURN™ GAMES ON YOUR SEGA SATURN™ SYSTEM.
\$39
 SUPER UHS CABLE
\$29.99

JAPANESE PLAYSTATION™
COMING SOON FOR PLAYSTATION™
BRAND NEW
BRAND NEW

DRAGON BALL Z
 SUPER BATTLE BROTHERHOOD I
\$39
\$29
NOT

UNIVERSAL ADAPTOR
\$39

NOMAD
BRAND NEW
BRAND NEW
\$19

TOMMO™
MAIL ORDER DIVISION
 FOR DEALER & WHOLESALE
 TEL: 818-839-8755 ON
 FAX: 818-839-8711
 eMail: tommsgames@aol.com
 INTERNATIONAL FAX: 818-839-8752
 LONG BEACH
 18221 E. Gale Ave. City of Industry CA. 91708
NINTENDO 64

NINTENDO 64
 JAPANESE NINTENDO 64 SYSTEM
\$399
 SUPER MARIO

Sega™ and Sega Saturn™ are registered trademarks of Sega Entertainment, Ltd. All rights reserved. All names and logos are the registered trademarks of their respective companies. Not responsible for any misspelling.

NEO GEO CDS



NEW RELEASES & UPCOMING TITLES



US PlayStation Titles

Arc the Lad
Beyond the Beyond
Crash Bandicoot
Die Hard Trilogy
F-1 Racing
Genso Suikoden
Jumping Flash 2
Legacy of Kain
Madden '97
NFL GameDay '97
Project Overkill
Soviet Strike
Tekken 2
Twisted Metal 2
Wipeout 2



U.S. Saturn Titles

Bug Too
Command and Conquer
Dragon Force
King of Fighters '95
Legend of Oasis
Magic Knight Ray Earth
Magami Tensei
Nights
NFL '97
Rayman 2
Sonic Extreme
Three Dirty Dwarves
Tom Raider
World Series Baseball '97



PlayStation Titles

Arc the Lad V.2
Dragon Ball Z Legend
Fatal Fury: Real Bout
Fighting Illusion
Jumping Flash 2
King of Fighters '95
Macross: Digital Mission VFX
Mega Turbo 2006
Namco Classic Series
New Japan Wrestling 2
Over Blood
Ranma 1/2
SD Gundam Galaxian
S.F. Zero 2
Samurai Showdown 3
Tekken 2
Tobal No 1
Wild Arms



Saturn Titles

Albert Odyssey Gaiden
Dragon Ball Z Legend
Fatal Fury Real Bout
Fighting Vipers
Gundam: Side Story
King of Fighters '95
Lunar Remix
Megan 8
Sailor Moon Super S
Samurai Showdown 3
Toshinden URA
V.F. Portrait Genesis
Virtua Cop 2
Virtua Fighter Kids
World Heroes Perfect

JAPANESE IMPORTS



POSTERS • TOYS • T-SHIRTS • NOVELTIES



1st Poster \$10.00 each additional poster \$7.00

GAME MUSIC



JAPANAMATION TITLES



Visit us at
New L.I. SHOWROOM
167 Glen Cove Rd.
Carle Place, NY 11514
Tel: (516) 248-4911 Fax: (516) 248-4913
L.I. Hours: Mon-Sat 10am-9pm;
Sun 11am-6pm

"BLOW OUT SPECIALS!"

SONY PLAYSTATION		SEGA SATURN	
Descent	\$19.99	Aladdin	29.99
Brain Dead 13	29.99	Alans 3	19.99
Gen	29.99	Incredible Hulk	19.99
Kirikak (DNA Imperative)	29.99	Mortal Combat	19.99
Lemming JD	09.99	Shanda 3	19.99
Nova Slalom	29.99	Sonic 2	19.99
Primal Rage	29.99	Spartanman TV Series	19.99
Raiden Project	29.99	Top Gear 2	29.99
View Point	29.99	WWF Arcade	39.99
WWF Arcade	39.99	WWF Royal Rumble	19.99
X-Com UFO Defense	29.99	X-Men	19.99
Zero Divide	29.99		

SUPER NINTENDO	
Address Family Value	19.99
Final Fight 2	39.99
Killer Instinct	29.99
Kirby's Avalanche	19.99
Punchy & Rocky 2	29.99
Rocky Robot	29.99
Scoby Doo	29.99
Secret of Evermore	39.99

We Carry Game Gear Game Boy V-Boy Jaguar 3DO SEGA CD Give us a Call!!!

GAME EXPRESS INC.
OVER 2000 TITLES IN STOCK, LOWEST PRICES
EMAIL US AT gexpress@gnn.com

For Ordering: (212) 290-0031
Dealer Hotline: (212) 290-0426
For Fax Order: (212) 290-0432
Visit Our Mega Showroom at:
126-128 W. 32nd St.
New York, NY 10001

*Prices do not include shipping & handling

Price and availability are subject to change without notice. We accept all major credit cards. Money Order and C.O.D. Allow 14 business days for shipping when paying by personal check. All sales are final, we will only replace defective items with the same title. Game Express Inc. is not responsible for misprint. NY residents add 8.25% sales tax to your order. All trademarks/trademarks are the properties of their respective owners

MASTER IT

AND GET A FREE

Take a bite out of your games with InterAct's Game Shark! Summer may be coming to an end, but that doesn't mean your games should. The Game Shark for the PlayStation or the Saturn is your ultimate weapon against those back-to-school blues! You can fight longer, kill more, score higher and go farther in every game! Forget those thumb-twisting combo-moves and complex finger exercises. The Shark gives you more power in every game, every day! You'll torch your enemies with the flamethrower in **RESIDENT EVIL**, grab your BFG in **DOOM**, laugh at death in **KRAZY IVAN**, and go for *nothin'* but net in **NBA SHOOTOUT**.

The Game Shark gives you codes for all the games in this ad and more! **More codes + more games + more fun!** With the Game Shark, you won't just own games anymore. You won't just play games anymore. You'll master the games — every game — you can get your hands on.

And check out InterAct Accessories' full line of high-performance controllers for the PlayStation and Saturn. InterAct gamepads and joysticks give you the quickest response, fastest fire, and deadliest precision of any controller on the market. With the Game Shark and an InterAct controller, you'll have ultimate power at your fingertips!

**COMING THIS FALL FOR NINTENDO 64 — SHARKPAD PRO Controller!
HAMMERHEAD Programmable Pad! FLIGHT FORCE PRO 64 Flight Control System!**



THE GAME!

GAME SHARK T-SHIRT!



InterAct Accessories wants to send you back-to-school in style with a limited edition GAME SHARK T-SHIRT - **FREE!** You can show the world that you have mastered the game!

To get your exclusive, **FREE, GAME SHARK T-SHIRT**, simply purchase a Game Shark for either the PlayStation or Sega Saturn, fill out the coupon below and send it to us with your original sales receipt. You'll be sporting a Shark shirt in no time!

**Offer
Extended
Through
October!**

SEND ME BACK TO SCHOOL IN SHARK STYLE!

I've purchased a Game Shark for the PlayStation or Sega Saturn.

Send my **FREE** shirt here!

NAME _____

ADDRESS _____

CITY _____ STATE _____ ZIP _____

PHONE _____ E-MAIL _____

MAGAZINE I CLIPPED THIS COUPON OUT OF:

GamePro EGM Next Generation Game Players

SYSTEM(S) I OWN:

PlayStation Sega Saturn PC Nintendo 64 Sega Genesis SNES

Rules for Redemption: Send your original store sales receipt reflecting purchase of a Game Shark dated between August 1 and September 30, 1996, along with this coupon to: InterAct Accessories, Inc., 10945 McCormick Road, Hunt Valley, MD 21031 Attn: BTS SHIRT. Coupon must include complete name and address for order to be fulfilled. Please allow 4-6 weeks for delivery. Offer applicable to residents of the 50 United States and Puerto Rico only. Offer expires 10/31/96. Only one shirt per household please.

October 31, 1996

**COMING
SOON!**

**NINTENDO 64
GAME SHARK**

www.gameshark.com

INTERACT

InterAct Accessories, Inc.
A RECOTON® COMPANY
10945 McCormick Road
Hunt Valley, MD 21031

Flex Some 16-Bit Muscle



More Challenges!
Face a life and death hunt to locate six Infinity Gems before Thanos. The fate of the world depends on you.



More Heroes!
Master the brute strength of your favorite Super Hero - Spider-Man, Wolverine, Iron Man, Captain America, and the Incredible Hulk.



More Super-Villains!
Battle fiendish hordes assembled by Thanos, including Blackheart, Dr. Doom and the diabolical evil clones of The Thing, Silver Surfer, Vision and a dozen others.

MARVEL
COMICS

MARVEL SUPER HEROES™ IN

**WAR
OF THE
GEMS™**

FLEX MORE 16-BIT MUSCLE!

The most powerful collection of Marvel Super Heroes unite to battle a multitude of treacherous villains on your Super NES! It's an incredible action-adventure demanding your skill, cunning and might to defeat the forces of evil and Thanos' quest for power.



Made with love by

RETROMAGS

Our goal is to preserve classic video game magazines so that they are not lost permanently.

People interested in helping out in any capacity, please visit us at retromags.com.

No profit is made from these scans, nor do we offer anything available from the publishers themselves.

If you come across anyone selling releases from this site, please do not support them and do let us know.

Thank you!