

BYTE

MAY 1989

A MCGRAW-HILL PUBLICATION

REVIEWS

Ami
Pocket Computers:
Wizard and Organiser
TrueScan vs. OmniPage
TopSpeed Modula-2
Logic Gem

PRODUCT FOCUS

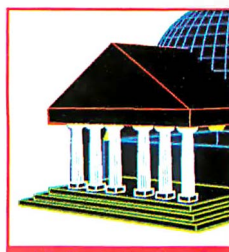

Unique tests of
3-D CAD packages

Sun's PC-PRICED WORKSTATIONS

New, affordable Unix alternatives
to the Mac II, PS/2 80, and NeXT computers

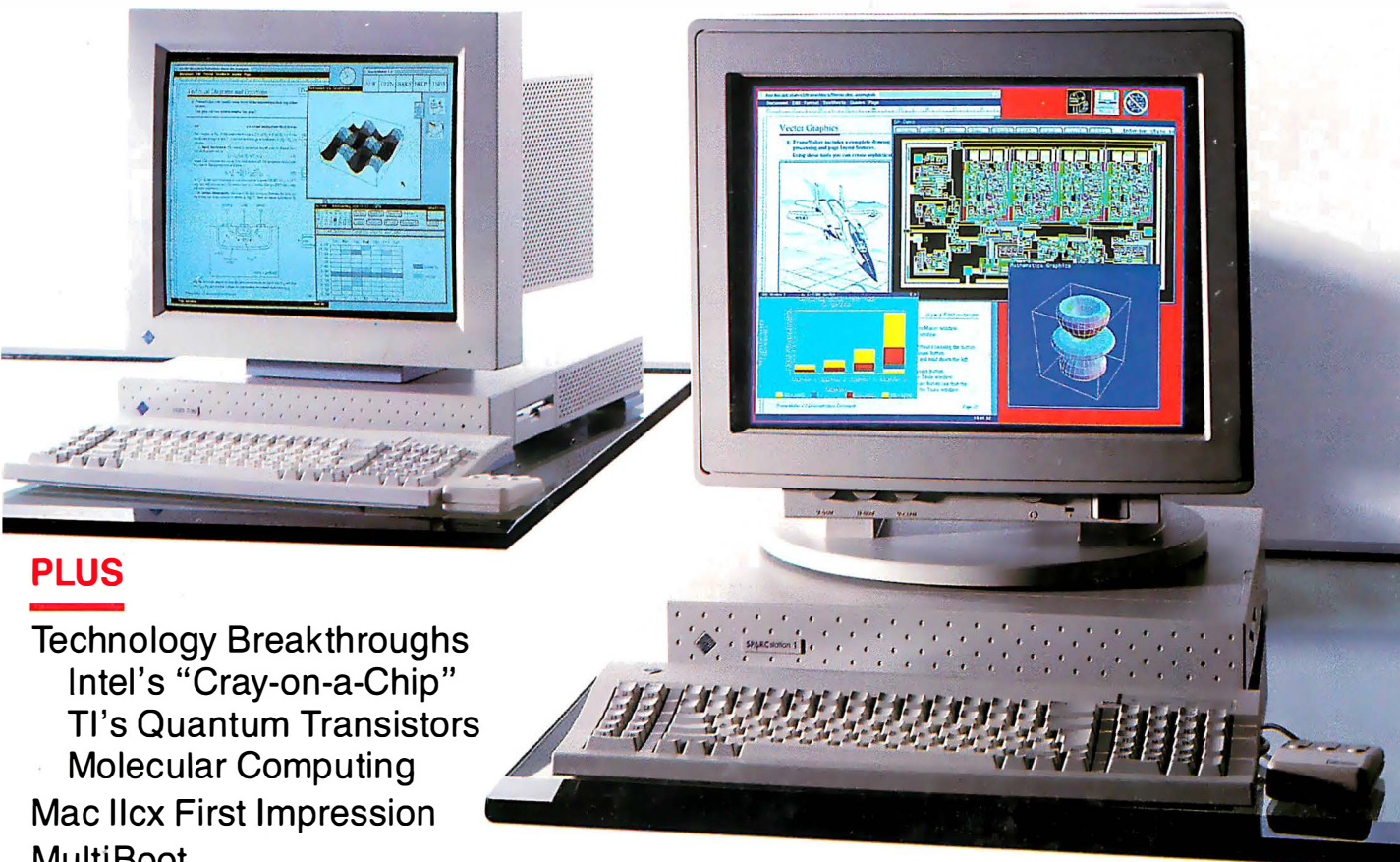

PLUS

- Technology Breakthroughs
- Intel's "Cray-on-a-Chip"
- TI's Quantum Transistors
- Molecular Computing
- Mac IIcx First Impression
- MultiBoot
- Lotus Magellan
- Disk Technician Advanced

02662



\$3.50 U.S.A./\$4.50 IN CANADA
0360-5280

05

Technically speaking, the System 325 is the most advanced 386™ computer we've ever built. And, according to PC Magazine, it's one of the most advanced 386 computers they've ever tested.

In benchmark after benchmark, the Dell System 325 25 MHz ran circles around a field

A PERSONAL COMPUTER THAT'S REALLY PERSONAL.

Of the more than 150,000 personal computers we've sold to date, each one's been individually configured to fit the needs of its owner.

The System 325 takes that idea

to its logical extreme.

For example, it runs either MS-DOS®, OS/2, or our own Dell UNIX® System V. Which is compatible with AT&T's System V Interface Definition. And the world of XENIX® applications.

If speed is of the essence, we can include an optional Intel^

**THE DELL 386 SYSTEM 325
HAS A 25 MHz CLOCK RATE,
CACHE MEMORY CONTROLLER,
90 MB 18ms ESDI DRIVE,
PAGE MODE INTERLEAVED MEMORY,
AND 100% COMPATIBILITY WITH
MS-DOS, OS/2 AND UNIX SYSTEM V.**

of 386-based systems. A field that included the Compaq^ 386/25.

A show of prowess that earned the System 325 PC Magazine's Editor's Choice award.

It was a goal we set for ourselves from the very beginning. And an objective anyone with a penchant for power and performance can appreciate.

80387 or WEITEK 3167 math coprocessor. And since nothing about this system is lightweight, the standard mass storage is a 90 MB ESDI disk drive. Or we can configure it with a 150 or 322 MB unit.

As you might expect, the output is just as intense. You can choose between VGA mono with paperwhite screen, or VGA Color



DOT MATRIX PRINTERS.

- Printer System 800: \$699.95
Our highest resolution text and graphics, 24-pin dot matrix printer. Draft quality at 200 cps. Letter quality at 66 cps. Parallel and serial interfaces. Wide carriage.
- Printer System 600: \$499.95
9-pin dot matrix. Draft quality at 240 cps. Near-letter quality at 60 cps. Parallel interface. Wide carriage.
- Printer System 300: \$199.95
9-pin dot matrix. Draft quality at 144 cps. Near-letter quality at 36 cps. Four standard fonts. Parallel interface. Narrow carriage.

LASER PRINTERS.



SO HOW COME YOU NEVER CALL?

THE DELL SYSTEM 325 25 MHz 386

STANDARD FEATURES:

- Intel 80386 microprocessor running at 25 MHz.
- Choice of 1 MB or 4 MB of RAM* expandable to 16 MB using a dedicated high speed 32-bit memory slot.
- Advanced Intel 82385 Cache Memory Controller with 32 KB of high speed static RAM cache.
- Page mode interleaved memory architecture.
- VGA systems include a high performance 16-bit video adapter.
- Socket for 25 MHz Intel 80387 or 25 MHz WEITEK 3167 math coprocessor.
- 5.25" 1.2 MB or 3.5" 1.44 MB diskette drive.
- Dual diskette and hard disk drive controller.
- Enhanced 101-key keyboard.
- 1 parallel and 2 serial ports.
- 200-watt power supply.
- 8 industry standard expansion slots.

OPTIONS:

- 25 MHz Intel 80387 math coprocessor.
- 25 MHz WEITEK 3167 math coprocessor.
- 1 MB or 4 MB RAM upgrade kit.
- 2 MB or 8 MB memory expansion board kit.

**Lease for as low as \$216/Month.

| System 325 | With Monitor & Adapter | | | |
|-------------------|------------------------|----------|----------------|----------|
| | VGA Mono | | VGA Color Plus | |
| Hard Disk Drives | 1 MB RAM | 4 MB RAM | 1 MB RAM | 4 MB RAM |
| 90 MB-18 ms ESDI | \$5,999 | \$7,299 | \$6,299 | \$7,599 |
| 150 MB-18 ms ESDI | \$6,499 | \$7,799 | \$6,799 | \$8,099 |
| 322 MB-18 ms ESDI | \$7,299 | \$8,599 | \$7,599 | \$8,899 |

Disclaimer: All systems are photographed with optional extras, which some computer retailers will often recognize.

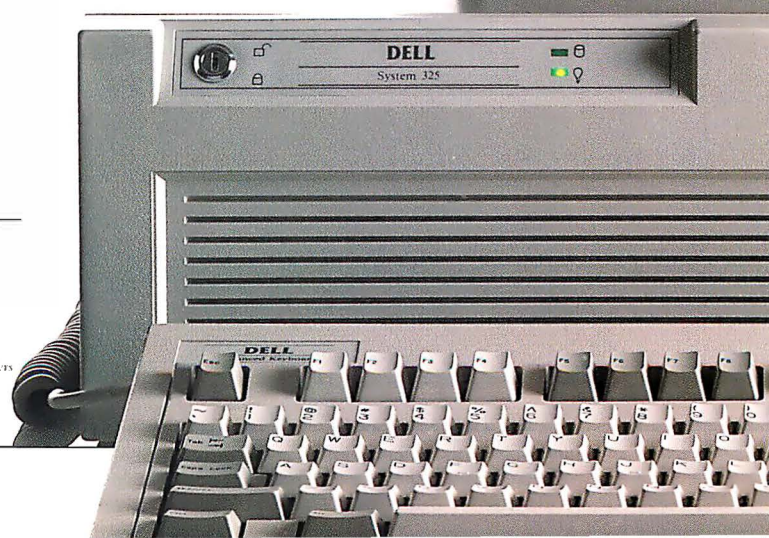
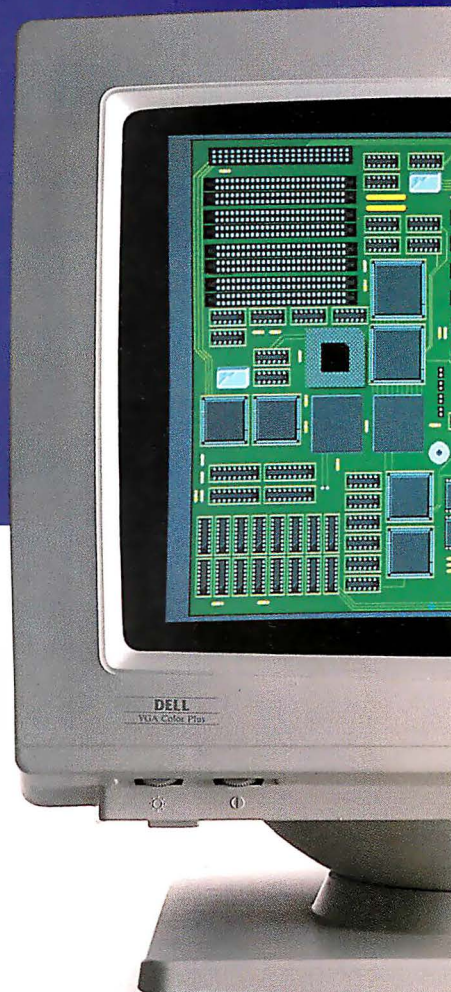

"The new top-of-the-line Dell System 325 is a flagship worth putting out in front of the fleet."

February 14, 1989

Laser System 150, 15 pages per minute: \$5,995.
 Laser System 80, 8 pages per minute: \$3,295.
 Laser System 60, 6 pages per minute: \$2,195.

All Dell laser printers come with 1.5 MBRAM, full-page 300 DPI graphics, and have 31 standard fonts (7 resident and 24 downloadable from diskette).

Dell laser printers also provide Hewlett-Packard LaserJet Plus[†], Epson/FX[‡], IBM Proprinter[†] and Diablo 630[†] emulations.

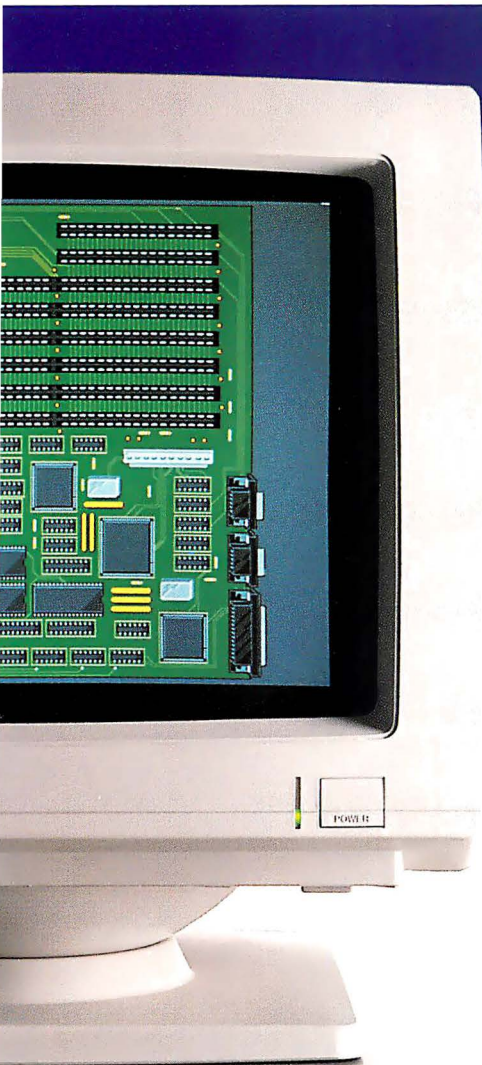

THE DELL SYSTEM 310
20 MHz 386.

The best combination of performance and value available.

STANDARD FEATURES:

- Intel 80386 microprocessor running at 20 MHz.
- Choice of 1 MB or 4 MB of RAM* expandable to 16 MB using a dedicated high speed 32-bit memory slot.
- Advanced Intel 82385 Cache Memory Controller with 32 KB of high speed static RAM cache.
- Page mode interleaved memory architecture.
- VGA systems include a high performance 16-bit video adapter.
- Socket for 20 MHz Intel 80387 or 20 MHz WEITEK 3167 math coprocessor.
- 5.25" 1.2 MB or 3.5" 1.44 MB diskette drive.
- Dual diskette and hard disk drive controller.
- Enhanced 101-key keyboard.
- 1 parallel and 2 serial ports.
- 200-watt power supply.
- 8 industry standard expansion slots.

OPTIONS:

- 20 MHz Intel 80387 math coprocessor.
- 20 MHz WEITEK 3167 math coprocessor.
- 1 MB or 4 MB RAM upgrade kit.
- 2 MB or 8 MB memory expansion board kit.

**Lease for as low as \$111/Month.

| System 310 | With Monitor & Adapter | | | |
|-------------------|------------------------|----------|----------------|---------|
| | Hard Disk Drives | VGA Mono | VGA Color Plus | |
| 40 MB-29 ms-11E | \$3,899 | \$5,199 | \$4,199 | \$5,499 |
| 90 MB-18 ms-ESDI | \$4,399 | \$5,699 | \$4,699 | \$5,999 |
| 150 MB-18 ms-ESDI | \$4,899 | \$6,199 | \$5,199 | \$6,499 |
| 322 MB-18 ms-ESDI | \$5,699 | \$6,999 | \$5,999 | \$7,299 |



THE DELL SYSTEM 220
20 MHz 286.

It's fast as most 386 computers. But at less than half the price. The footprint is small, too.

STANDARD FEATURES:

- 80286 microprocessor running at 20 MHz.
- 1MB of RAM* expandable to 16MB (8 MB on system board).
- Page mode interleaved memory architecture.
- LIM 4.0 support for memory over 1 MB.
- Integrated diskette and VGA video controller on system board.
- Socket for Intel 80287 math coprocessor.
- One 3.5" 1.44 MB diskette drive.
- Integrated high performance hard disk interface on system board.
- Enhanced 101-key keyboard.
- 1 parallel and 2 serial ports (integrated on system board).
- 3 full-sized industry standard expansion slots available.

OPTIONS:

- External 5.25" 1.2 MB diskette drive.
- 3.5" 1.44 MB diskette drive.
- Intel 80287 math coprocessor.
- 1 MB or 4 MB RAM upgrade kit.

**Lease for as low as \$86/Month.

| System 220 | With Monitor | |
|-----------------------------|--------------|----------------|
| | VGA Mono | VGA Color Plus |
| Hard Disk Drives | | |
| One Diskette Drive | \$2,299 | \$2,599 |
| 40 MB-29 ms-11E Hard Disk | \$2,999 | \$3,299 |
| 100 MB-25 ms-ESDI Hard Disk | \$3,599 | \$3,899 |



THE DELL SYSTEM 200
12.5 MHz 286.

This full-featured 286 computer runs at 12.5 MHz, and is completely Microsoft MS-DOS and MS OS/2 compatible.

STANDARD FEATURES:

- 80286 microprocessor running at 12.5 MHz.
- 640 KB of RAM expandable to 16 MB (4.6 MB on system board).
- Socket for Intel 80287 math coprocessor.
- 5.25" 1.2 MB or 3.5" 1.44 MB diskette drive.
- Dual diskette and hard disk drive controller.
- Enhanced 101-key keyboard.
- 1 parallel and 2 serial ports.
- 200-watt power supply.
- 6 industry standard expansion slots.

OPTIONS:

- Intel 80287 math coprocessor.
- 512 KB RAM upgrade kit.
- 2 MB RAM update kit.

**Lease for as low as \$93/Month.

| System 200 | With Monitor & Adapter | |
|-------------------|------------------------|----------------|
| | VGA Mono | VGA Color Plus |
| Hard Disk Drives | | |
| 40 MB-40 ms | \$2,499 | \$2,799 |
| 40 MB-28 ms | \$2,699 | \$2,999 |
| 90 MB-18 ms-ESDI | \$3,199 | \$3,499 |
| 150 MB-18 ms-ESDI | \$3,699 | \$3,999 |
| 322 MB-18 ms-ESDI | \$4,499 | \$4,799 |

*Performance enhancements (Systems 325, 310 and 220) Within the first megabyte of memory, 384 KB of memory is reserved for use by the system to enhance performance.

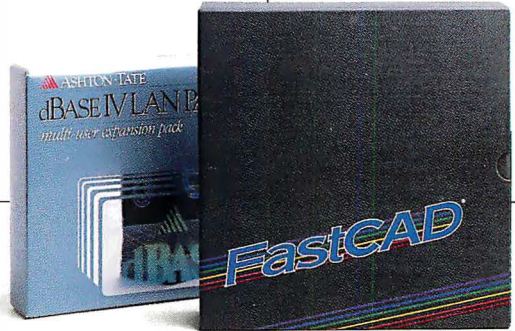

APPLICATION SOFTWARE.

We offer a complete line of software. Everything from complex CAD/CAM applications to fun flight simulator programs. All at extremely competitive prices.

OPERATING SYSTEM SOFTWARE.

- Dell Enhanced Microsoft[®] MS-DOS[®] 3.3: \$99.95.
- Dell Enhanced Microsoft MS-DOS 4.0: \$119.95.
- (Both MS-DOS versions with disk cache and other utilities)
- Dell Enhanced MS[®] OS/2 Standard Edition 1.0: \$324.95.
- Dell UNIX[®] System V/386, Release 3.2: Now Available. Call for details.

All prices and specifications are subject to change without notice. Dell cannot be responsible for errors in typographical or photographic. *Bundles based on a 36-month open-ended lease. †Leasing arranged by Leasing Group, Inc. In Canada, configurations and prices will vary. Microsoft, MS, MS-DOS, and XENIX are registered trademarks owned by Microsoft Corp. 386 is a trademark of Intel Corporation. UNIX is a registered trademark of AT&T. Dell UNIX System V is based on INTERACTIVE Systems Corporation's 386iX[™]. ‡Siemens trademarks of entities other than Dell Computer Corporation. †Service remote locations may incur additional travel charges. © 1989 DELL COMPUTER CORPORATION.

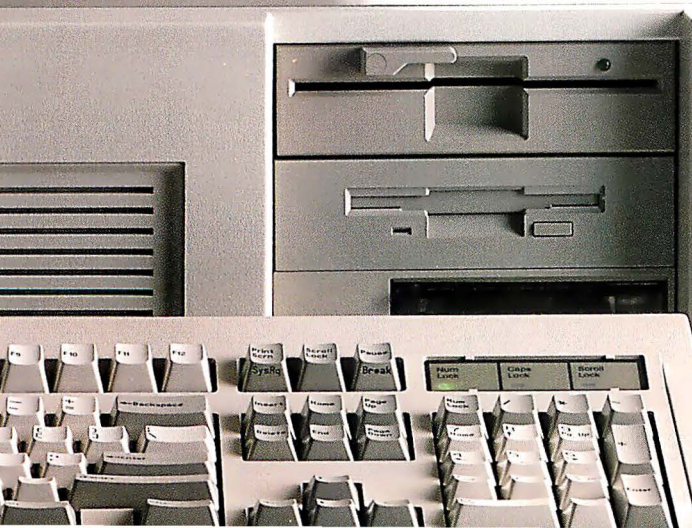

Plus, for high resolution colors displayed on a larger screen.

Even though the 325 gives you all this performance, it still leaves you six open slots for whatever else you might want to add.

And once you've told us what you want, we'll make sure what you want works—by burning-in the entire system unit.

COMPUTER RETAILERS ARE NO KNOWS.

In all probability, the average computer retailer won't have any understanding what makes the System 325 go.

He will, however, be quite aware of the fact that he could add a 35% markup if he could sell it in his store.

Which he can't.

Because we sell direct.

Meaning you now have the unique opportunity to talk directly with a computer expert. And ask things like, "What's the difference between IDE and ESDI?" Or, "How much SIMM RAM should I add?"

In other words, the kinds of questions you should be able to ask a retailer, but usually can't.

So as you might suspect, dealing direct not only saves you the 35% markup, but 100% of the aggravation.

DELL
COMPUTER
CORPORATION

Marty Brands
Account Representative

955 ARBORETUM BLVD., AUSTIN, TEXAS 78754-7299

FAX (512) 727-4320

TEL (512) 426-5150



WE COME WHEN WE'RE CALLED.

One of the things that very clearly sets a Dell system apart

from other computers is not just how they're sold, but how they're supported.

Overkill was one description used in a PC Week article.

Perhaps.

But then, we think you'll agree, when something goes wrong, you want as much help as

we'll refund your money.

No questions asked.

MAYBE YOU SHOULDN'T BUY ONE AFTER ALL.

No matter how many reasons we give you to buy a Dell system, sometimes it makes more sense to lease one instead.

BEST OF ALL, YOU WON'T HAVE TO EXPLAIN TO A COMPUTER RETAILER WHAT ALL THAT MEANS.

possible, right?

Which is why every Dell system comes with a toll-free technical support line and self-diagnostic software. We're able to solve 90% of all problems right over the phone. The other 10% receive next-day, desk-side service. Thanks to our new alliance with Xerox Corporation.

And you get all this help for a full year—whenever you need it—at no extra charge.^Δ

As you've probably guessed, one of the things that drives us most is customer satisfaction.

So we'd like to give you the ultimate guarantee: Try a System 325 in your office for a month. Run your toughest applications. Put it through its paces, at your pace. If you're not completely satisfied, send it back anytime within 30 days. And

Whether you need a single computer, or an office full, a leasing plan is like 100% financing.

And just as we can custom configure your computers, we can see to it you get a custom designed lease plan to fit your exact business needs. † A fact that has not gone unnoticed. Especially by the Fortune 500. Over half of whom now own or lease Dell systems.

And just as we welcome their business, we welcome your business, too. Just call us, toll-free. And don't be afraid to ask us the tough questions.

That's the part we like best.

DELL
COMPUTER
CORPORATION

TO ORDER, CALL
800-426-5150

IN CANADA, CALL 800-387-5752
IN GERMANY, CALL 06103/701100
IN THE U.K., CALL 0800 414535

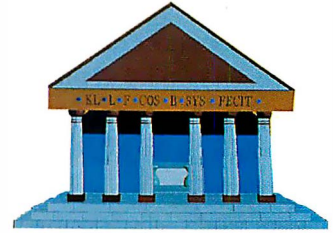

REVIEWS

PRODUCTS IN PERSPECTIVE

- 65 **What's New**
- 97 **Short Takes**
Lotus Magellan, a DOS file management system
Virtual, Connectix offers more Mac RAM for less
Compaq Fixed Disk Drive Expansion Unit, 1.2 gigabytes of on-line storage
MultiBoot, Bolt's answer to OS/2's dual-boot problem
Disk Technician Advanced, Prime Solutions' program predicts hard disk drive problems

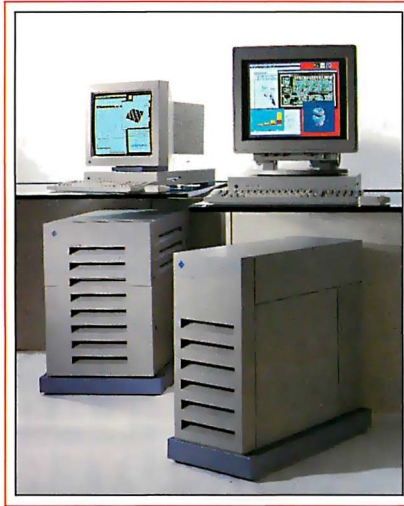

COVER STORY

FIRST IMPRESSIONS

Two Powerful Systems from Sun by Nick Baran page 108

The SPARCStation 1 and the Sun-3/80 offer workstation performance at PC prices.

FIRST IMPRESSIONS

- 113 **Intel's Cray-on-a-Chip**
by Frank Hayes
Intel's new high-speed 80860 RISC microprocessor features an on-chip FPU and a 3-D graphics processor.
- 117 **Apple's New Compact Mac IIx**
by Nick Baran
Apple's "mainstream" Mac II model has three slots, a 68030, and a petite footprint.

- 178 **Product Focus: The Third Dimension**
by Brad Holtz and Jon Udell
Three-dimensional modeling brings new excitement to microcomputer-based CAD.
- 195 **Computing in Hand**
by Wayne Rash Jr.
The Sharp Wizard and the Psion Organiser—two hand-held computers that pack a lot of functionality into a small size.
- 203 **Easy Reading**
by Phillip Robinson
TrueScan and OmniPage add page-recognition capabilities to the Mac or PC.
- 208C **Mac Goes Fax**
by Don Crabb
With fax modems for the Mac, claims of speed are less important than price and flexibility.

EXPERT ADVICE

- 123 **Computing at Chaos Manor: Springtime Renewal**
by Jerry Pournelle
What was once old is now new again.
- 143 **Applications Plus: Software Despotism: Truth and Fiction**
by Ezra Shapiro
The software you use at work could become a thorny professional issue.
- 151 **Down to Business: Uncommon Commonality**
Wayne Rash Jr.
Software that works on a number of different machines can save time, trouble, and money.



- 157 **Macinations: A Perfect Word Processor At Last?**
by Don Crabb
The search for the ideal writer's tool for the Mac might be over.
- 163 **OS/2 Notebook: Setting Up OS/2**
by Mark Minasi
Installing OS/2? Here are a few tricks, and some traps to avoid.
- 178 **COM1: The Mac Makes Connections**
by Brock N. Meeks
Mac-to-mainframe connectivity is about to become a reality.

- 211 TopSpeed Modula-2**
by *Barry Nance*
Produce efficient code in an integrated environment with JPI's compiler.
- 217 A Different Kind of CASE Tool**
by *Andrew Schulman*
Sterling Castle's Logic Gem is both a code generator and a logic interpreter.
- 221 A Window on Word Processing**
by *Lamont Wood*
Samna's Ami is one of the first word processors to take advantage of Microsoft Windows.

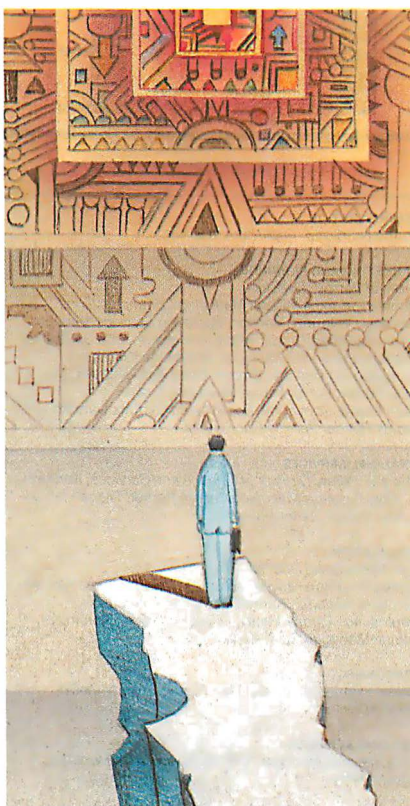

Quest for the Molecular Computer/268

HANDS ON

- 283 Under the Hood: Digital Video Interactive**
by *L. Brett Glass*
Digital audio, video, still pictures, and computer graphics form a personal computer environment.
- 291 Some Assembly Required: Directory Assistance, Part 1**
by *Rick Grehan*
The directory could be the single most important data structure in your computer.

IN DEPTH

- 225 Introduction: Unix**
- 227 Future Imperfect**
by *David Fiedler*
A view of recent developments in the Unix operating system and processors.
- 237 One Man's Experience**
by *John Unger*
Making the switch from DOS to Unix—a true story.
- 245 The Unix Connection**
by *Ben Smith*
Many small systems never take advantage of the UUCP tools, nor of the worldwide network that the tools connect.
- 253 Safe and Secure?**
by *Patrick Wood*
Unix comes with a lot of security systems, but it's up to you to turn them on and use them.
- 261 Interrupts Aren't Always Best**
by *George E. Pajari*
The choice between interrupts and polling in a Unix device driver can significantly affect performance.
- 266 Some Flavors of Unix**
A sampling of the forms of Unix available.

FEATURES

- 268 The Quest for the Molecular Computer**
by *Mark A. Clarkson*
Can we make computers that are smaller than living cells and faster than light?
- 275 The Quantum Transistor**
by *Mark Reed*
The rules of semiconductor physics don't apply on the molecular level.

Unix/225

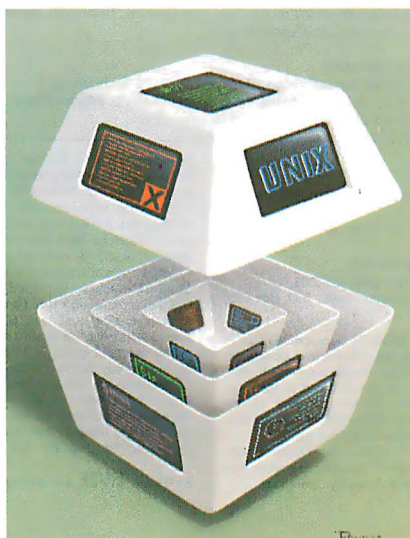

DEPARTMENTS

- 6** Editorial:
A Lot of Company
- 11** Microbytes
- 24** Letters and Ask BYTE
- 45** Chaos Manor Mail
- 51** Book Reviews
- 343** Coming Up in BYTE

READER SERVICE

- 342** Editorial Index by Company
- 344** Alphabetical Index to Advertisers
- 346** Index to Advertisers by Product Category
- Inquiry Reply Cards: after **348**

PROGRAM LISTINGS

From BIX: See **176**

From BYTEnet:
call (617) 861-9764

On disk or in print:
See card after **288**

BYTE (ISSN 0360-5280) is published monthly with an additional issue in October by McGraw-Hill, Inc. Postmaster: Send address changes, USPS Form 3579, and fulfillment questions to BYTE Subscriptions, P.O. Box 551, Hightstown, NJ 08520. Second-class postage paid at Peterborough, NH 03458, and additional mailing offices. Postage paid at Winnipeg, Manitoba. Registration number 9321. Printed in the United States of America.

Not responsible for lost manuscripts or photos. Opinions expressed by the authors are not necessarily those of BYTE.

Copyright © 1989 by McGraw-Hill, Inc. All rights reserved. Trademark registered in the United States Patent and Trademark Office.



Subscription questions or problems should be addressed to: BYTE Subscriber Service, P.O. Box 551, Hightstown, NJ 08520.

BYTE

EDITOR IN CHIEF
Frederic S. Langa

PUBLISHER/GROUP VICE PRESIDENT
J. Burt Totaro

OPERATIONS

Glenn Hartwig *Associate Managing Editor*

REVIEWS (Hardware, Software, Product Focus)

Michael Nadeau, *Associate Managing Editor*, Dennis Allen *Senior Technical Editor, Software*, Richard Grehan *Director, BYTE Lab*, Stephen Apiki *Testing Editor, BYTE Lab*, Stanford Diehl *Testing Editor, BYTE Lab*

NEWS AND TECHNOLOGY (Microbytes, What's New, Short Takes)

Rich Malloy *Associate Managing Editor*, D. Barker *Senior Editor, News and Technology*, Anne Fischer *Lent Senior Editor, New Products*, Andrew Reinhardt *Associate News Editor*

Peterborough: Roger Adams *Associate News Editor*, David Andrews *Associate News Editor*, Martha Hicks *Associate News Editor*

West Coast: Gene Smarte *Bureau Chief*, Costa Mesa, Nicholas Baran *Senior Technical Editor*, San Francisco, Frank Hayes *Associate News Editor*, Marlene Nesary *Associate News Editor*, Jeffrey Bertolucci *Editorial Assistant*, San Francisco

SENIOR TECHNICAL EDITORS

Ken Sheldon *Features*, Jane Morrill *Tazelaar in Depth*, Tom Thompson *At Large*

TECHNICAL EDITORS

Janet J. Barron, Robert Mitchell, Ben Smith, Jon Udell, Stanley Wszola

CONSULTING EDITORS

Jerry Pournelle, Ezra Shapiro, Don Crabb, Brett Glass, Brock N. Meeks, Mark Minasi, Wayne Rash Jr.

CONTRIBUTING EDITORS

Jonathan Amsterdam *Programming Projects*, Mark Dahmke *Video, Operating Systems*, Mark Haas *At Large*, Rik Jadrnick *CAD, Graphics, Spreadsheets*, Robert T. Kurosaka *Mathematical Recreations*, Alastair J. W. Mayer *Software*, Stan Miastkowski *New Technology*, Alan R. Miller *Languages and Engineering*, Dick Pountain *Algorithms*, Roger Powell *Computers and Music*, Phillip Robinson *Semiconductors*, Jon Shiell *High-Performance Systems*, George A. Stewart, *Book Reviews*, Ernest Tello *Artificial Intelligence*

COPY EDITORS

Lauren Stickler *Chief*, Cathy Kingery *Copy Administrator*, Susan Colwell, Jeff Edmonds, Judy Grehan, Nancy Hayes, Margaret A. Richard, Warren Williamson

EDITORIAL ASSISTANTS

Peggy Dunham *Office Manager*, Linda C. Ryan, June N. Sheldon, Lynn Susan Valley

ART

Nancy Rice *Director*, Joseph A. Gallagher *Assistant Director*, Lisa Nardecchia *Assistant*, Jan Muller *Assistant*, Alan Easton *Technical Artist*

PRODUCTION

David R. Anderson *Director*, Virginia Reardon *Senior Editorial Production Coordinator*, Barbara Busenbark *Editorial Production Coordinator*, Denise Chartrand *Editorial Production Coordinator*, Michael J. Lonsky *Editorial Production Coordinator*

TYPOGRAPHY

Sherry Fiske *Systems Manager*, Donna Sweeney *Applications Manager*, Christa Patterson

ADVERTISING/PRODUCTION (603) 924-6448

Lisa Wozmak *Director of Advertising Services*, Lyda Clark *Senior Account Coordinator*, Karen Cilley, Linda Fluhr; Wai Chiu Li *Quality Control Manager*, Rod Holden; Julie Murphree *Creative Services Manager*, Jeanne Gatcombe

ADMINISTRATION

Donna Nordlund, *Publisher's Assistant*

MARKETING AND PLANNING

Michele Perron, *Director*
Pamela Petrakos-Wilson *Marketing Communications Manager*, Wilbur S. Watson *Marketing Services Manager*, Dawn Matthews *Public Relations Manager*, Lisa Jo Steiner *Assistant Promotion Manager*, Stephanie Warnesky *Marketing Art Director*, Sharon Price *Associate Art Director*, Julie Perron *Senior Market Research Analyst*, Faith Kluntz *Copyrights Coordinator*, Cynthia Damato *Sands Reader Service Coordinator*

FINANCIAL SERVICES

Philip L. Penny *Director of Finance and Services*, Kenneth A. King *Business Manager*, Marilyn Parker, Diane Henry, JoAnn Walter, Jaime Huber

CIRCULATION

Dan McLaughlin *Director*
James Bingham *Newstand Sales Manager*, Vicki Weston *Assistant Manager*, Karen Desroches *Distribution Coordinator*, Donna Healy, *Direct Accounts Coordinator*, Louise Menegus *Back Issues*

PERSONNEL

Patricia Burke *Personnel Coordinator*, Beverly Goss *Receptionist*

BUILDING SERVICES

Tony Bennett *Manager*, Cliff Monkton, Mark Monkton, Agnes Perry



BYTE INFORMATION EXCHANGE

DIRECTOR

Stephen M. Laliberte

EXECUTIVE EDITOR

George Bond

MANAGING EDITOR

Tony Lockwood

MICROBYTES DAILY

D. Barker *Coordinator*, Peterborough, Rich Malloy *New York*, Gene Smarte *Costa Mesa*, Nicholas Baran *San Francisco*, Rick Cook *Phoenix*, Frank Hayes *San Francisco*, Martin Heller, *Boston*, Jason Levitt *Austin, TX*, Larry Loeb *Wallingford, CT*, Brock N. Meeks *San Francisco*, Stan Miastkowski *Peterborough*, Wayne Rash Jr., Sue Rosenberg *Washington, DC*, David Reed *Lexington, KY*

GROUP MODERATORS

David Allen *Applications*, Leroy Casterline *Other*, Marc Greenfield *Programming Languages*, Jim Howard *Graphics*, Gary Kendall *Operating Systems*, Steve Krenek *Computers*, Brock N. Meeks *Telecommunications*, Barry Nance *New Technology*, Donald Osgood *Computers*, Sue Rosenberg *Other*, Jon Swanson *Chips*

EXCHANGE EDITOR

Larry Loeb, *Macintosh Exchange Editor*

BUSINESS AND MARKETING

Patricia Bausum *Secretary*, Denise A. Greene *Customer Service*, Brian Warnock *Customer Service*, Tammy Burgess *Customer Credit and Billing*

TECHNOLOGY

Clayton Lisle *Director*, *Business Systems Technology*, ISCo., John Spadafora *Programmer/Analyst*, Wayne Power, *Senior Business Systems Analyst*

EDITORIAL AND BUSINESS OFFICE:

One Phoenix Mill Lane, Peterborough, NH 03458, (603) 924-9281.

West Coast Branch Offices: 425 Battery St., San Francisco, CA 94111, (415) 954-9718; 3001 Red Hill Ave., Building #1, Suite 222, Costa Mesa, CA 92626, (714) 557-6292.

New York Branch Editorial Office: 1221 Avenue of the Americas, New York, NY 10020, (212) 512-3175.

BYTEnet: (617) 861-9764 (set modem at 8-1-N or 7-1-E; 3000 or 1200 baud).

Editorial Fax: (603) 924-2550. Advertising Fax: (603) 924-7507. Telex: (603) 924-7861.

SUBSCRIPTION CUSTOMER SERVICE: Outside U.S. (509) 426-7070; inside U.S. (800) 525-5003.

For a new subscription—(800) 257-9402 U.S. only, or write to BYTE Subscription Dept., P.O. Box 555, Hightstown, NJ 08520.

Officers of McGraw-Hill Information Services Company: President: Walter D. Serwatka. Executive Vice Presidents: Kenneth E. Gazzola, Aerospace and Defense; Ira Herenstein, Computers and Communications; Russell C. White, Construction; Robert P. McGraw, Healthcare; Brian H. Hall, Legal. Senior Vice Presidents—Publishers: Laurence Altman, Data Communications; David J. McGrath, Engineering News-Record. Senior Vice Presidents: Robert D. Daleo, Finance; Michael J. Koeller, Human Resources. Group Vice Presidents: J. Burt Totaro, BYTE; Norbert Schumacher, Energy/Process Industries. Vice Presidents: George Elsingner, Circulation; Julia Lenard, Systems Planning and Technology.

Officers of McGraw-Hill, Inc.: Joseph L. Dionne, Chairman, President, and Chief Executive Officer; Robert N. Landes, Executive Vice President, General Counsel, and Secretary; Robert J. Bahash, Executive Vice President and Chief Financial Officer; Frank D. Penglase, Senior Vice President, Treasury Operations.

Founder: James H. McGraw (1860–1948). Executive, editorial, circulation, and advertising offices: One Phoenix Mill Lane, Peterborough, NH 03458, phone (603) 924-9281. Office hours: Monday through Thursday 8:30 AM–4:30 PM, Friday 8:30 AM–1:00 PM, Eastern Time. Address subscriptions to BYTE Subscriptions, P.O. Box 551, Hightstown, NJ 08520. Subscriptions are \$29.95 for one year, \$54.95 for two years, and \$74.95 for three years in the U.S. and its possessions. In Canada and Mexico, \$31.95 for one year, \$59.95 for two years, \$79.95 for three years. \$75 for one-year air delivery to Europe. \$28,800 for one-year air delivery to Japan. \$14,400 for one-year surface delivery to Japan, \$45 surface delivery elsewhere. Air delivery to selected areas at additional rates upon request. Single copy price is \$3.50 in the U.S. and its possessions, \$3.95 in Canada, \$4.50 in Europe, and \$5 elsewhere. Foreign subscriptions and sales should be remitted in U.S. funds drawn on a U.S. bank. Please allow six to eight weeks for delivery of first issue. Address editorial correspondence to: Editor, BYTE, One Phoenix Mill Lane, Peterborough, NH 03458. Unacceptable manuscripts will be returned if accompanied by sufficient postage. Where necessary, permission is granted by the copyright owner for libraries and others registered with the Copyright Clearance Center (CCC) to photocopy any article herein for the flat fee of \$1.50 per copy of the article or any part thereof. Correspondence and payment should be sent directly to the CCC, 29 Congress St., Salem, MA 01970. Specify ISSN 0360-5280/83, \$1.50. Copying done for other than personal or internal reference use without the permission of McGraw-Hill, Inc., is prohibited. Requests for special permission or bulk orders should be addressed to the publisher. BYTE is available in microform from University Microfilms International, 300 North Zeeb Rd., Dept. PR, Ann Arbor, MI 48106 or 18 Bedford Row, Dept. PR, London WC1R 4EJ, England.

BYTE and BYTE are registered trademarks of McGraw-Hill, Inc.

At last, an assistant that follows your directions

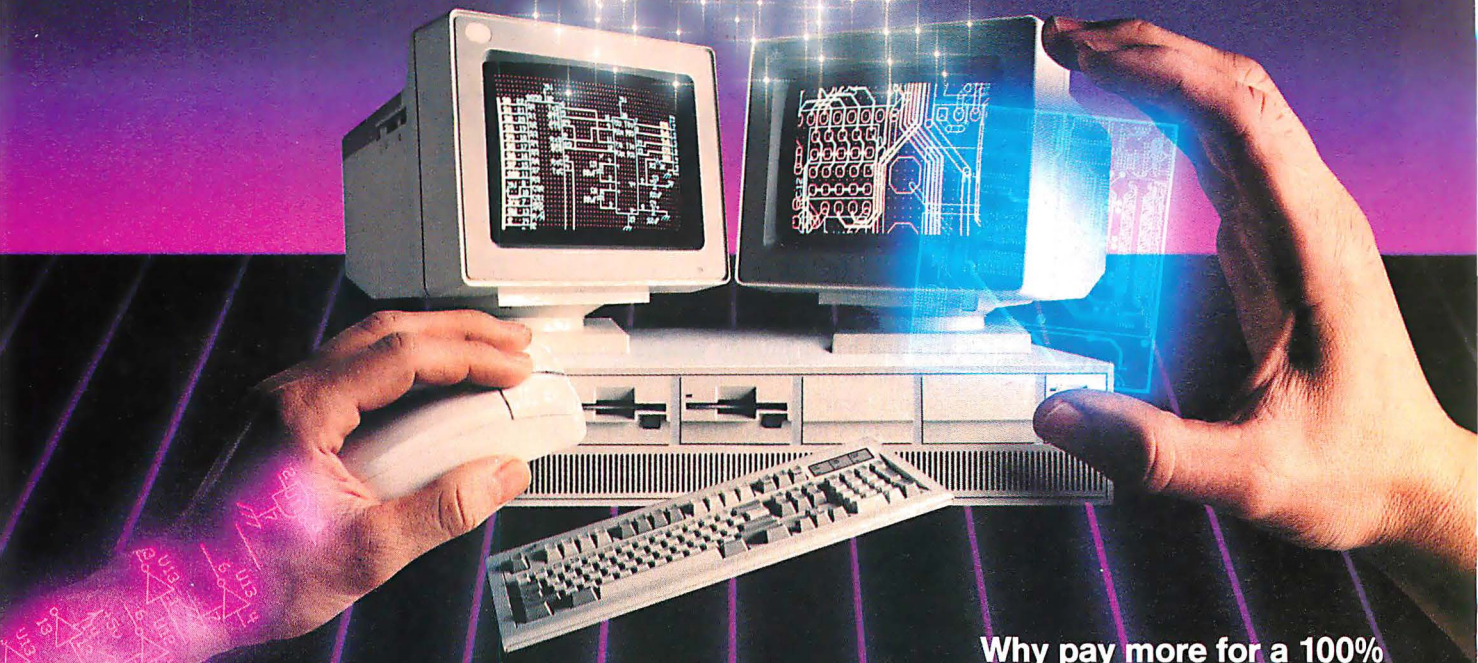

Wouldn't it be great to delegate your routing?

You can! We know your time is valuable. That's why Wintek pioneered comprehensive and affordable CAD packages for IBM personal computers. HiWIRE-Plus continued that tradition, integrating schematic-capture features and printed-circuit-artwork capabilities into one versatile package.

New autorouter.

The Autorouter for HiWIRE-Plus is powerful enough to handle the most demanding design problems, yet simple enough for a casual user. Just turn it loose on your design. It's hassle free because it works long hours, without supervision or errors.

100% autorouting.

The autorouter for HiWIRE-Plus rips-up, reroutes, and with appropriate design rules, racks up 100% completion.

- Forget gridded routers. This autorouter places vias and traces anywhere your design rules allow. With 1-mil resolution.
- Vary trace width and spacing for individual networks. Route 1, 2, 3, or more tracks between IC and connector pins.
- Set up boards from 1 to 250 layers, up to 60" x 60".
- Specify shape, size, and type of vias, layer-by-layer: through-hole, blind, buried, micro. Specify via types for individual networks.
- Use fewer vias and layers than comparably priced autorouters.
- For use on your IBM PC, XT, AT, PS/2, or compatible with 640K RAM.

Why pay more for a 100% autorouter?

Compare the features and performance to packages costing five times more. HiWIRE-Plus and the Autorouter for HiWIRE-Plus sell for \$895 each. Both have a no-nonsense, 30-day money-back guarantee. With unlimited, toll-free, no-charge technical support.

Let HiWIRE convince you that it makes a great assistant. Call us toll-free at (800) 742-6809 today and put HiWIRE-Plus and the Autorouter for HiWIRE-Plus to work for you tomorrow.



Wintek Corporation
1801 South Street
Lafayette, IN 47904-2993
Fax: (317) 448-4823
Phone: (317) 742-8428 or

(800) 742-6809

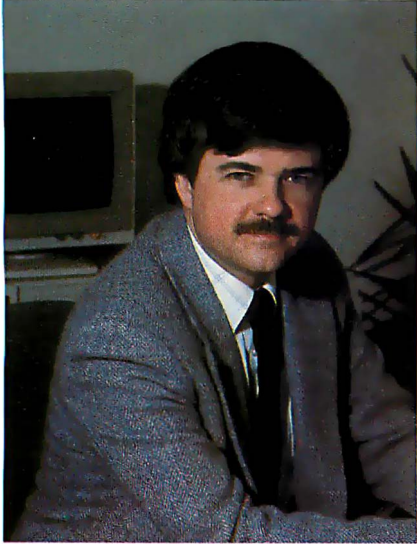

A LOT OF COMPANY

A report from West Germany shows worldwide links you might not know about

Hannover, West Germany—CeBIT, the world's largest computer and telecommunications exhibition, opened here in March, and, as always, BYTE was on the scene.

BYTE has a large and growing circulation in Europe. In fact, BYTE is the largest Pan-European computer magazine, with wide circulation in every country on the Continent, including the USSR. BYTE also goes to Asia, Africa, Australia, and South America. BYTE's English-language edition alone reaches over 1.5 million readers worldwide. And this isn't the only edition. BYTE's content is also licensed to other independent publications across the globe, appearing in numerous languages. You have a lot of company as you read this issue.

And it's a two-way street. By sending our editors around the globe and by working with people in other countries, BYTE can give you thorough coverage of not only the products available in your local computer store, but also significant desktop computer technologies and products from the increasingly important global market.

Witness our recent coverage of Japan's TRON project, Scotland's Rekursiv object-oriented chip, Soviet software, and so on. Our Microbytes service on BIX regularly carries news and product information from Europe and our friends at *Nikkei BYTE* in Japan. No other computer magazine brings you coverage like this.

Here's a sampling of what we saw at CeBIT, as reported by Senior Technical Editor Nick Baran:

CeBIT (which is a German acronym for Center for Office and Information Technology) draws about 3000 exhibitors and half a million visitors from all over the world.

This year's CeBIT kicked off West Germany's major commitment to ISDN telecommunications. ISDN allows the integration of text, graphics, video images, and voice communications on a single digital line. In an event that aired on West German television, the Post Office Minister, Dr. Schwarz-Schilling, introduced the first ISDN network in West Germany, with about 8000 nodes in eight major cities. Prime Minister Helmut Kohl participated in a multimedia conversation via ISDN with the mayor of Frankfurt. West Germany hopes to have a nationwide ISDN network by 1993.

One of the most popular exhibitors at CeBIT was Atari, which displayed its hand-held PC Folio "pocket computer." PC Folio runs MS-DOS and uses the 80C88 microprocessor. The device is about 8 inches long, 4 inches wide, and an inch thick. It has a 63-key keyboard and an 8-line, 40-character LCD.

One of the more interesting exhibits was Toshiba's prototype 14-inch color LCD. Based on active matrix technology, the display supports the VGA standard and displays 16 colors, with a resolution of 720 by 550 pixels. Toshiba also showed an 11-inch version of the display in a prototype laptop computer.

Almost 200 U.S. companies exhibited at CeBIT this year. Among them were Microsoft, Apple, IBM, Commodore, Novell, and Compaq.

Commodore is a major player in the West German microcomputer market. Sporting an enormous exhibition booth in the main hall at CeBIT, Commodore announced a Unix-based version of its Amiga 2500, which it is calling the Amiga 2500 UX, and a new version of its PC40 AT system, called the PC40-III.

The Amiga 2500 UX is virtually identical to the Motorola 68020-based Amiga

2500, except that it uses a separate 68851 processor for memory management. The clock speed of the 2500 UX is 14.2 MHz, and the machine comes standard with a 68881 math coprocessor and 3 megabytes of main memory. As is customary at West German product announcements, pricing for the 2500 UX was not discussed.

Big Blue looks as dominant as ever in West Germany. With over 7000 square meters of exhibition space in seven different locations at CeBIT, IBM's presence was felt in every technical category, from telecommunications to scientific and engineering applications.

IBM has major research and development projects under way in Stuttgart. Some of these projects were displayed at CeBIT. One of the most interesting was a language-comprehension project using an IBM PS/2. The objective is to make the computer understand the linguistic and logical relationships of German text so that the machine can answer questions about a given document stored in the computer.

A prototype using a 200-word description of a hiking trail was demonstrated. The program takes the text and breaks it down into its grammatical components (i.e., nouns, verbs, objects, and so forth) and then represents each sentence of the text in a logical form that is conceptually similar to an organizational chart. In the demonstration, the system was asked, "Where does the trail end?" The system answered, "The answer to your above question is: In Stuttgart." The language-comprehension project is a joint effort of IBM and several German universities and is planned for completion in 1991.

If it—or any other worldwide development—holds promise to make your use of your computer more productive and worthwhile, you can count on BYTE to bring you the news.

—Fred Langa
Editor in Chief
(BIX name "flanga")

DISCOVER COMPLETE

Gateway 2000 set out 4 years ago with one goal in mind. To be the #1 direct we knew that we had to provide "complete customer satisfaction". As we see quality equipment at the best price available anywhere. The customer has addition to this we had to build a reputation for incredible service that was confidently say that we have achieved these goals. Although we are not yet have thoroughly checked out the competition, and suggest that you do the GATEWAY 2000 computer system. And we can guarantee you that we will system. If you won't take our word for it take a look at what our customers chosen by BYTE magazine for their annual BYTE awards. Our 386-20 was Call us toll-free to discover "complete customer satisfaction".

"We are very happy that our system is at the top of the stack in both price and performance, but it is your courteous service that is uncontested by the competition."

— Pierce Haviland — Kingston, NY

"Overall, I feel that your product is outstanding and your service has been excellent."

— Eric Shogren — Stonington, CT



12 Mhz 286 VGA

2 Megs RAM
1.2 Meg 5 1/4" Drive
1.44 Meg 3.5" Drive
40 Meg 28ms SCSI Drive
10 Mbits/Sec DTR
16 Bit VGA Board
14" VGA COLOR Monitor
1 Parallel/2 Serial Ports
101 Key Keyboard
MS DOS 4.01

\$2295.00

16 Mhz \$2395.00

20 Mhz \$2495.00



25 Mhz 386 VGA

4 Megs RAM
1.2 Meg 5 1/4" Drive
1.44 Meg 3.5" Drive
150 Meg 16.5 ms ESDI Drive
10 Mbits/Sec DTR
16 Bit VGA Board
14" VGA COLOR Monitor
1 Parallel/2 Serial Ports
101 Key Keyboard
MS DOS 4.01

\$4495.00

(Call for 33 Mhz Option)



20 Mhz 386 VGA

1 Meg RAM
1.2 Meg 5 1/4" Drive
1.44 Meg 3.5" Drive
80 Meg 28ms SCSI Drive
10 Mbits/Sec DTR
16 Bit VGA Board
14" VGA COLOR Monitor
1 Parallel/2 Serial Ports
101 Key Keyboard
MS DOS 4.01

\$2995.00

(Upgrade to 4 Megs \$500)

All systems have a 30 day Money Back Guarantee and 1 Year Warranty.
Due to the Volatility in the DRAM Market all prices subject to change.

CUSTOMER SATISFACTION

marketer of micro computers in the nation. In order to attain this lofty goal it, to achieve "complete customer satisfaction" we had to supply the best to feel that he or she received most value for their hard earned money. In completely unheard of in the mail-order business. At this point we can the largest company in the market we strongly feel that we are the best. We same. We want you to feel entirely confident of your decision to purchase a do everything in our power to keep you satisfied after you receive your are saying about us. In addition to this we were the only "clone" company chosen out of the hundreds of products they reviewed for it's overall value.

- *"It is a refreshing experience to work with a company that trys very hard to give real service to the little guy."*
John Curran
Simi Valley, CA
- *"It is evident that the level of integrity at Gateway 2000 is high and definitely confidence inspiring."*
Elias Ilyia, Ph.D.
Seattle, WA

1 9 8 8

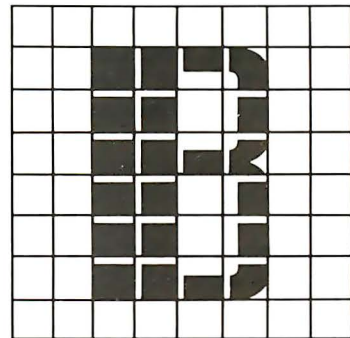

B Y T E

A W A R D O F

D I S T I N C T I O N

Gateway 2000
P. O. Box 2000
Sgt. Bluff, IA 51054
800-233-8472
712-943-2000





Creative License.

If you've ever tried to combine windows, menus, forms, and text entry to create an effective user interface, you know how challenging it can be.

Perhaps you've turned to a third-party library for help. Only to run into restrictions, limitations, and dead ends. So you had to compromise your design. Or modify the library source code. Or start over.

Which is precisely why we designed Vermont Views™, the new generation of Windows for Data®, the best-selling C library for user interfaces.

Vermont Views offers unbridled, unrestricted creative license.

The Human Interface Of Your Dreams

Vermont Views offers an unparalleled set of interface building blocks that you can combine in unlimited ways:

- Menus can be created in any style you choose, made scrollable vertically and horizontally, and nested to any level. Features include n-th character selection, checkmarks, and unavailable items.

- Data entry forms can be bigger than their display windows, have scrollable regions for the entry of variable lines of items, lists of choices for data entry, context sensitive help, and special decimal, date, time, and toggle fields.

- A mini word processor can be attached to a field window in a form or

used as a pop-up note taker.

You're In Charge

Because you can write and attach functions to the beginning and end of menus, forms, fields, and to keys, you're always in control.

Use these control functions to call up subsidiary forms and menus, change field values and the active field, exit or abort a form, do almost any task you can imagine.

All interactive capabilities of Vermont Views use a unique system of accessible keytables, so you can easily change or disable key assignments – even add to the functions provided for menus, forms, text entry, and windows.

One For All

Vermont Views is available for DOS, OS/2, UNIX, XENIX, and VMS. Maintain the same user interface on all of these operating systems with the same source code.

Vermont Views provides international portability as well, with full support for IBM international characters, flexible date and time formats, and changeable decimal and thousands separators.

Novice Or Expert

Despite its depth and flexibility, Vermont Views is easy to learn and use. Each major facility is covered in a single, self-

contained section of the manual, so you only need to learn capabilities as you use them.

To help you become an expert in no time, we include a free copy of the Norton Guides™ Engine and our own comprehensive Pop-Up Reference™. You'll have immediate, on-line access to function names, reference pages, structures and tables.

No-Time-Limit Guarantee

We've only touched on a fraction of what makes Vermont Views special. The only way to know it is to use it.

Try Vermont Views on your hardest problems.

For as long as you want. At no risk.

If not fully satisfied, return for a full refund. Anytime.

To Order Today Call 1-800-848-1248

Call to order Vermont Views today. And we'll send your "creative license" right away.

Prices: DOS \$395; with Source \$790. UNIX, XENIX, VMS, OS/2 please call.



Vermont
Creative
Software

Pinnacle Meadows, Richford, VT 05476

800-848-1248, 802-848-7731 Fax: 802-848-3502 Telex: 510-601-4160 VCISOFT

MICROBYTES

Staff-written highlights of developments in technology and the microcomputer industry, compiled from Microbytes Daily and BYTEweek reports

Diamond Film Has Promise for Tough Hard Disks

If it's true that diamonds are forever, the hard disk of the future might last "forever" if current research in diamond films proves successful. Researchers are working on synthetically producing thin carbon films that have the diamond crystalline structure; they're using a chemical process involving methane and hydrogen, two abundantly available raw materials.

Diamond, the hardest known raw material, also has a very low coefficient of friction and very high heat resistance, making it an excellent material for coating hard disk platters. While current oxide and metal-plated hard disk media suffer from "head crashes" and other problems due to wear and corrosion, diamond-film-coated hard disks would be much more reliable.

Several computer companies, including IBM, Seagate, and Hewlett-Packard, are interested in diamond-film technology, according to professor Stig Hagstrom of Stanford University's Department of Materials Science and Engineering. (Japanese companies actively involved in diamond-film studies are "ahead" of research developments in the U.S., he said.) Hard disks with diamond-film coatings are only "one to three years away," Hagstrom said.

The tricky part in all this is consistently producing diamond film. "If you're unlucky," Hagstrom said, "you end up with graphite." Another

considerable challenge is developing improved techniques for depositing the diamond film on a substrate. It's currently necessary to deposit the film at a temperature of 600°C, making the process impractical with plastics used in floppy disks. However, the high processing temperature does not present a problem for metal hard disk platters.

In the longer term, diamond film offers great potential as a semiconductor. Diamond is in the same family of elements as silicon and germanium and could conduct current at three times the speed of silicon (diamond has three times the "hole mobility" of silicon). Diamond film has much higher heat resistance than silicon and could operate as a transistor at temperatures from 6°C to 700°C, allowing much higher power than can be achieved from silicon. But before they can manufacture diamond transistors, chip makers will have to come up with effective "doping" techniques, which introduce impurities into the pure film material for controlling the electronic properties of the semiconductor. The Japanese have successfully doped diamond film. However, diamond semiconductors are probably five to ten years away, said Hagstrom.

For more information, contact Dr. Stig Hagstrom at the Stanford University Department of Materials Science and Engineering, Stanford, CA, (415) 723-2558.

Backplane Bus up Against the Wall; Designers Looking to New Architectures

The backplane bus architecture used on computers today will hit its peak performance levels in the next few years, several experts in the field predict. "We've hit the brick wall," said bus designer David Gustavson at the recent Buscon '89 conference. The most promising backplane-bus concept currently in the works is the Futurebus project (IEEE standard 896.1), which designers

hope will offer transfer rates of 200 to 300 megabytes per second (the fastest buses in use today offer transfer rates well under 20 megabytes per second). Futurebus represents the "end of the road" for conventional backplane bus architecture, said Paul Borrill of National Semiconductor. "Futurebus will be the last great bus."

The problem with backplane tech-

continued

NANOBYTES

Any doubts about Intel's 80860 RISC processor showing up in personal computers were dispensed with at the 80860's official debut. The major demo at the rollout pitted a Sun-4/110 (using a SPARC chip) against a Silicon Graphics Personal IRIS (with a MIPS chip) against an IBM PS/2 Model 80 that had a prototype 33-MHz 80860 bus-master card in it. The PS/2 was running OS/2 and used its 80386 for nothing but flashing up the dots generated by the 80860. Each system was running the same Mandelbrot fractal program; the PS/2 was the fastest. IBM executive James Cannavino confirmed that IBM and Intel are working on developing the bus-master card as a possible commercial product. Big Blue watchers still don't know how to interpret Cannavino code, but we think he was saying it's a product we'll be able to buy in a year or so.

Portable OS/2: "Making OS/2 popular is priority 1, 2, 3, 4, 5, and 6," says Microsoft's vice president of systems software, Steve Ballmer. The company is intent on making OS/2 widely used and plans to port it to non-IBM-type systems. Microsoft won't produce such an operating system for at least two years, but when it does, portable OS/2 will be going head to head with Unix, an established portable operating system that's been getting more ink than a candidate for Secretary of Defense.

Motorola wants to make its 88000 RISC processor a big hit in the Unix workstation market, but right now the chip is going through the stage of no commercial software. The **88open Consortium**, an independent group of companies whose biggest financial backer is Motorola, is trying to persuade developers to write for the 88000

continued

NANOBYTES

processor. The group's new Software Initiative Organization consists of 30 software vendors committed to providing programs for the 88000 RISC architecture. The organization will also certify software that's fully compatible with the 88000 Binary Compatibility Standard, which is based on AT&T Unix version 5.3 but will be compatible with Unix 5.4 when it's released later this year or early next year.

Initial backers of the SIO include some **major Unix software vendors**, such as ABSOFT (FORTRAN compilers), Frame Technology (desktop publishing), Informix (database management software), and Insignia Solutions and Phoenix Technologies (MS-DOS emulation software). So far, Sanyo/Icon, Data General, and Opus/Everex have introduced 88000-based systems.

Bernardo Huberman, a research fellow at Xerox PARC who spoke at the Clearpoint-sponsored chaos conference, eloquently described the world as being surrounded by a vast "**computational membrane**." As new generations of computers are linked into the world grid, Huberman said, chaos will inevitably become a major problem. Thinking about the effects of chaos on large networks of the future can be both sobering and frightening. The world banking system already relies on large networks, as do international companies like Hewlett-Packard, and spawning networks—giant multi-tasking environments wherein computing tasks roam in search of free computing resources—are expected to be a component in the theoretical "Star Wars" strategic defense system.

The Extended Industry Standard Architecture bus will overtake the Micro Channel in about a year, says a man who sells bus connectors. Fernando Ramirez, a sales engineer at Burndy Corp.—which makes EISA and Micro Channel connectors—says his company already has big commitments to buy EISA connectors

continued

nology is that it's inherently a "broadcast only" mechanism. "Only one guy can talk at a time," explained Gustavson. Current handshake protocols are limited by the time required for the signal to propagate from the sender to the receiver and then for a response to return to the sender.

While the Futurebus project greatly improves (theoretically) the performance of current bus technology, the only way to make significant gains is to introduce a new architecture, according to Gustavson. Current technologies might reach maximum data transfer rates of 200 megabytes to 300 megabytes per second, but new bus designs will be needed to reach transfer rates of 1 gigabyte per second or more.

Gustavson, an engineer at the Stanford Linear Accelerator; David James and Paul Sweazey of Apple Computer; and John Moussouris of MIPS Computer have been working on a new architecture, called the Scalable Coherent Interface (SCI), that employs the concept of parallel "point-to-point interconnects." In the SCI model, bursts of data are transmitted at one time, similar to the packet concept used on LANs. The packets of data are sent along "unidirectional links" from the CPU to a cache controller and finally to a SCSI interface that ties together incoming and outgoing links. Gustavson showed a prototype model of the concept using a modified Micro Channel board that had what Gustavson called a "transmitter" soldered on to it.

According to Gustavson, the initial target transfer rate is 1 gigabyte per second per processor, with a

maximum of 65,000 processors. In the ultimate SCI configuration, the 20 terabytes (that's 20,000 gigabytes) of data stored in the Library of Congress could be moved three times per second, according to Gustavson.

While current bus technology will peak out at transfer rates of about 300 megabytes per second, the gigabyte-per-second transfer rate of SCI may very well be needed in the next 10 years. The proposed Super Collider project in Texas, for example, will handle 400,000 gigabytes of raw data every year. The 100-MFLOPS processors of the future will require 1-gigabyte-per-second transfer rates to achieve full utilization.

There are, of course, some major technological hurdles to jump before the SCI project becomes a reality. First, there are currently no VLSI chips capable of handling the proposed transfer rates of 1 gigabyte per second or more. Second, the cache coherency mechanism, designed to make sure that a system never allows one processor to change a piece of data without all the other processors knowing about it, has not been fully worked out.

However, the SCI project is no pie in the sky. Gustavson said the technology for the VLSI chips will be available in the next year or two. The project now has an IEEE project number (IEEE 1596) and a sizable commitment of resources from Apple, Hewlett-Packard, and Norsk Data, Gustavson said.

For further information, contact David Gustavson at the Stanford Linear Accelerator, P.O. Box 4349, Stanford, CA 94309, (415) 926-2863.

New FORTRAN Standard at Least a Year Away

You can talk about C, you can talk about C++, you can talk about Ada, and you can talk Smalltalk. But when it comes to science and engineering applications, FORTRAN is still the world's standard programming language. And it's in dire need of an upgrade. FORTRAN 77, established in 1977, is the most recent standard; the last time FORTRAN was updated, Jimmy Carter was president, Eddie Murray and Andre Dawson were baseball's rookies of the year, and Radio Shack was selling the TRS-80 Model I for \$599.95. The forthcoming standard

has been known as FORTRAN 8X, which optimistically indicates that it will be ready sometime in this decade.

However, it looks like a new FORTRAN standard won't be ready until some time in 1990, according to Jerrold Wagener, vice chairman of the ANSI X3J3 subcommittee, which is working out the technical specifications of the new standard. At a recent meeting in Palo Alto, California, about 50 members of X3J3 hashed out details such as whether to have an INCLUDE statement in FORTRAN

continued

To learn Microsoft QuickBASIC, you only need a manual this thick.

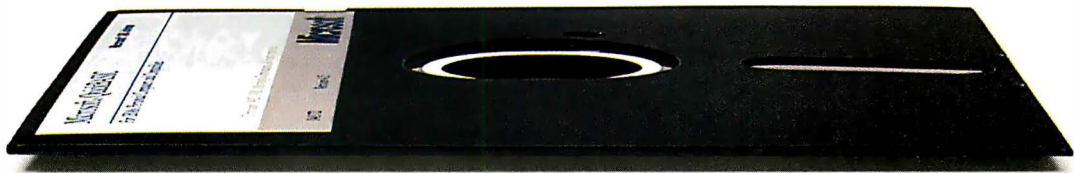

You're looking at something you won't see anywhere else.

It's called QB Advisor. A remarkable new hypertext electronic manual that can make you instantly more productive, even if you don't know the first thing about programming. QB Advisor actually lets you experiment by cutting and pasting useful sample programs right into your programming window. Only Microsoft has it. Only Microsoft could. And it's just one of the things you'll learn about new Microsoft® QuickBASIC version 4.5 for IBM® PCs and compatibles.

Another is the step-by-step tutorial that actually takes you through every stage of programming by working you through a complete program.

And QB Express—the interactive way to learn all about your programming environment in a matter of minutes—not hours.

Microsoft QuickBASIC also comes with Easy Menus that let you develop programs with

a minimum number of menu choices. Context-sensitive Help for immediate help with error messages and variables by simply punching a key, or clicking a mouse. And a built-in debugger that lets you see exactly what your program is doing, as it's doing it.

Best of all, Microsoft QuickBASIC is packed with enough power to handle whatever problems drove you to programming in the first place. Fact is, it translates your program into executable code at an incredible 150,000 lines per minute.

Microsoft QuickBASIC version 4.5. If programming is the only way out, this is the easiest way in.



Microsoft®
Making it all make sense.

"Personally, if everyone was pushing me for laser quality, I'd go with Fujitsu. They've got everything you need—Adobe PostScript, upgradeability, affordability—the works."



Letters. Graphics. Desktop publishing. Where will you ever find one printer that can handle them all?

Right here.

It's the new RX7100 series of personal page printers from Fujitsu.

Take a look at the desktop-sized RX7100 model. Perfect for most of your printing needs, with HP LaserJet™ Plus emulation, dual paper bins and a one-piece toner and drum cartridge for ease of replacement. When it comes to paper handling, the RX7100 is a real pro, automatically feeding anything from envelopes to legal size paper from the same bin.

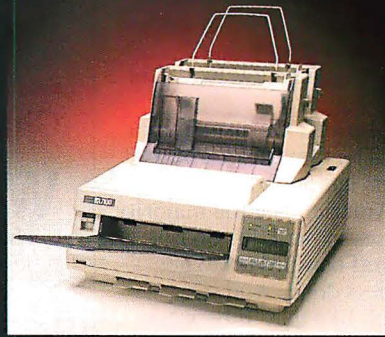

For true desktop publishing, the RX7100PS+ model adds Adobe® PostScript®, 35 resident fonts, 4 MB memory, HP LaserJet Series II® emulation with AppleTalk®, plus parallel and serial interfaces. So it's compatible with every system in your office, and then some.

The best part is, you can begin with the economical RX7100 and easily upgrade it to the top-of-the-line RX7100PS+ whenever you're ready.

Questions? Just call 1-800-626-4686.

Personally, we think everyone will thank you for it.

Fujitsu RX7100. The Personal Page Printer.



FUJITSU AMERICA
Computer Products Group

Circle 110 on Reader Service Card (DEALERS: 111)

NANOBYTES

from several makers of IBM PC AT compatibles, including **Hewlett-Packard, Olivetti, and Everex**. The EISA connector features a bilevel slot that can accommodate boards made for ATs as well as the 32-bit EISA boards when they arrive.

Not everyone foresees Easy Street for EISA-based computer systems. At Buscon '89, several bus watchers said **EISA is just a ploy** by PC clone makers to get IBM to lower its licensing fees for Micro Channel patents. EISA has the backing of Compaq, Zenith, Hewlett-Packard, Tandy, and other major makers of PC-compatible hardware.

Is it a revolution? Or just a minor rebellion? The **Gartner Group** claims in its latest study of computers in America that the majority of businesses in the U.S. **do not use personal computers** to get their business done. And it doesn't look like they'll be working with them any time soon. According to a Gartner study of 45,000 executives at 8000 business places around the country, 70 percent of all "nonfarm, nonresidential businesses do not possess a PC." Of those questioned, 9 percent said they planned to buy one this year.

The **National Institute of Standards and Technology** (formerly the National Bureau of Standards) is setting up a research program to study **security and management** issues relating to networks that use Open Systems Interconnection architecture or ISDN communications. NIST seeks joint participants who will provide funding, equipment, or staff. Contact NIST, B151 Technology Building, Gaithersburg, MD 20899.

As everybody in this industry knows, Apple is pushing hard to get its **Macs into corporate America**. Whether or not it's succeeding is a matter of conjecture and how much you believe the league of analysts. But one Mac watcher says **HyperCard's scripting language** is helping push

continued

(similar to the `#include` command in the C language) or whether "percent" and "dot" are equivalent notations. Among many other changes, the new FORTRAN will feature enhanced array operations, dynamic data structures, user-defined data types, pointers, and new regulations for numeric precision.

Agreeing on a new standard is an incredibly complex task. Many proposals have been contributed from FORTRAN programmers around the world. The committee must vote on each of these proposals.

The International Organization for Standards (ISO) is also working on a new FORTRAN standard, and that group's effort must be coordinated

with the ANSI work so that a single standard emerges.

"It's very critical to have a new standard," Wagener said. "It would be of tremendous benefit to scientific programming and would make the programming process much more efficient."

The X3J3 committee hopes to have its final proposal ready for public comment this fall. The document is nearly 400 pages long.

Anyone interested in reviewing or commenting on the FORTRAN 8X standard can obtain further information from J. L. Wagener, X3J3 Vice Chairman, Amoco Production Research, P.O. Box 3385, Tulsa, OK 74102.

Chaos Study Could Affect Computers, Networks

Will computers unlock the secrets of chaos? Will the science of chaos lead to drastically new types of computers? Chaos, or what the scientists more accurately call nonlinear dynamic systems, integrates the disciplines of physics, math, computer science, and biology. At a recent conference sponsored by Clearpoint Research, experts from those fields discussed the implications of using computers to study chaos and chaos's effect on the future of computer design. (By way of parenthetical and grossly simplified background, chaos is the tendency for systems to exhibit unpredictable, seemingly random behavior. Consider water flowing over a waterfall: All the supercomputers in the world couldn't predict the path an individual drop of water might take.)

Norman Packard, one of the innovators of chaos science and the director of the Center for Complex System Research, said the most immediate use of computers in the chaos field is in attempting to model chaos, doing what he termed "capturing real-world dynamics within the artificial world of the computer." But while computer simulation and modeling isn't exactly a new field, Packard said chaos modeling will eventually result in radical new computer designs that will change computers "from dumb brutes into innovative creatures."

Packard holds out little hope that existing studies of artificial intelligence and expert systems will make

any dramatic change in computers, saying that research is resulting in "brittle" systems that "don't have the ability to explore on their own." Current neural net research is a step in the right direction, he said, but researchers need to work harder to design models that "press up against the limits of predictability."

But while Packard sounded optimistic that chaos research will result in a "sharp transition" to a new breed of computers, he declined to speculate on details, saying it's a "science that's just being born." He did predict that computers of the future will consist of a "combination of randomness and structure" and said it might well be 10 to 20 years before we'll see commercial applications of these new systems.

While chaos studies might some day result in a new breed of computers, a more immediate problem is being studied by Bernardo Huberman, a research fellow at Xerox's Palo Alto Research Center (PARC). Huberman's research is pointing to potential problems caused by chaos factors in computer networks. As networks get larger, some begin to exhibit what Huberman terms "wildly unpredictable behavior." While this isn't a problem in a typical local-area (or even wide-area) network, PARC is developing next-generation "spawning networks" in which unpredictable behavior could be a problem.

A spawning network is a multi-tasking environment in which comput-

continued

BRIDGES

With Sysgen Bridge-Files,
data *can* get there from here.

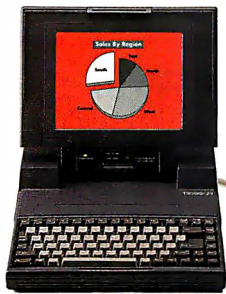

Toshiba® T3100 with NEW Bridge-Laptop™ 5.25/T. Work on 5.25" diskettes with your Toshiba laptops (T3100 and up). Dual capacities of 360Kb and unique 1.2Mb capacity—*more* than available from Toshiba!



Compaq® Deskpro™ with Bridge-File 3.5. Lets all popular PC compatibles access 3.5" PS/2 and laptop files. Dual 720Kb and 1.44Mb capacities.

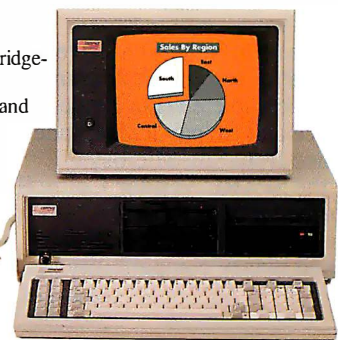

IBM® PS/2™ Model 30 286 with Bridge-File™ 5.25. Now compatible with DOS 4.0 and OS/2™. Give ALL your 3.5" systems easy access to 5.25" disks. Dual capacity 360 Kb/1.2 Mb access to all files.

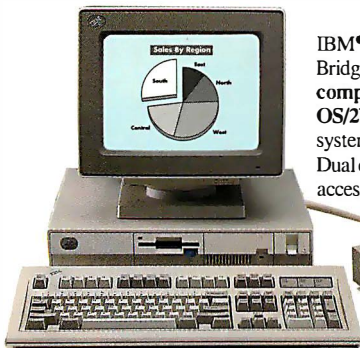

IBM PC/AT™ with Bridge-File 3.5. With Bridge-File any IBM PC/XT™ or AT generation computer can be upgraded to share information with your newer systems.

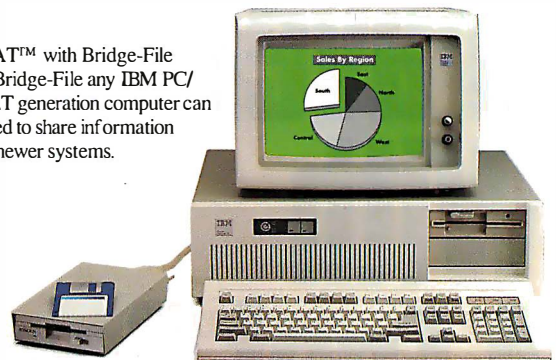

The problem.

Your PCs, PS/2s, Toshiba laptops and PC compatibles may share the same office. But still be worlds apart.

Different floppy disk sizes and formats can yield isolated information *islands* instead of productive work *groups*.

The Solution: Bridge-File 5.25 and Bridge-File 3.5 drives.

The only complete bridge family in the industry, Bridge-Files *can* get your data from here to there. And vice-versa. Your different computers will be working with common diskettes in no time flat.

Bridge-File 5.25 gets rave reviews for

its small footprint, ease of use and dual capacities. With over 100,000 at work for satisfied users, it's a proven best-seller. Now your PS/2s, Toshiba laptops and other 3.5" systems can access your PC files.

Bridge-File 3.5 lets your 5.25" PCs access files from other, 3.5" systems. And Bridge-File 3.5 functions as *either* an external or internal drive. Make all your current information accessible to all your computers.

Omni-Bridge™ Controller.

Control up to *four* 5.25", 3.5" and floppy tape drives in any combina-



tion. Omni-Bridge makes XT/AT upgrades easy — you get access to all your data, twice the transfer speed and increased storage. And it's economical — at \$95, Omni-Bridge is too good to pass up.

**For literature or the Bridge-File dealer nearest you, call:
1-800-821-2151**

SYSGEN

INCORPORATED

Sysgen Incorporated, 556 Gibraltar Drive, Milpitas, CA 95035.
©Copyright Sysgen, Inc. 1989. All trademarks above are the property of their respective holders.

NANOBYTES

Macs into corporate offices. At the recent Software Development '89 conference, consultant, author, and HyperTalk expert **Dan Shafer** said HyperTalk has specifically fueled Mac purchases because it lets users design their own front ends to applications. There's been "a surge in interest over the last six months because folks want to use Macs as front ends to databases nobody can understand," said Shafer. "Put a cartoon in front of a database, and people think they understand it better."

In a move to give the Sun-driven Scalable Processor Architecture (SPARC) complete vendor independence and, in particular, independence from Sun Microsystems, the **SPARC Vendor Council** has formed a "not for profit" organization to oversee the development and binary compatibility of

continued

ing tasks automatically migrate to machines that have free computing resources. In a spawning network, the database sort and report process that you start in one window before jumping to another application can actually be performed as a "spawned process" on some other machine in the network in a process completely transparent to the user.

According to Huberman, processes in spawning networks essentially "bid" for free computing resources. The lack of a central control in a spawning network is both its biggest advantage and the cause of unpredictable chaotic problems, he

said. Individual processes don't always "know" the state of the network and can sometimes cause situations that either lock up the network or cause it to act strangely. Huberman calls the whole thing a "computational ecosystem," and he said that his group is studying the ecology of biological systems in an effort to draw a parallel with what's happening in a spawning network.

Chaos scientists aren't ones to make glib predictions. They like to point out that despite millions of dollars spent on computers, weather services haven't become more accurate in their forecasts.

Unix Is One-Half of IBM's System Strategy

IBM is stepping up its investments in its Unix-based systems and software and is "dead serious about this market," IBM's U.S. general manager told a crowd of Unix users, developers, and vendors. Delivering the keynote address at UniForum in San

Francisco in March, Terry Lautenbach told the audience that IBM has "a long way to go to establish a leadership position" but that the company is committed to the Unix market. Lautenbach said IBM is "very pleased"

continued

Travel With A Fast Crowd.



Wherever your business takes you, take along the WorldPort 2400™ Portable Modem. Leaving the office doesn't have to mean leaving behind the world of high-speed, 2400 bps communications. Worldwide, in virtually every situation, including hotel rooms and phone booths, your ability to communicate clearly and efficiently remains intact.

Representing the cutting edge of modem technology, the WorldPort line of portable modems combine a broad range of features that bring you the best value in modems today. Features

that go far beyond costly internal units, such as Bell and CCITT standards, direct connect and acoustic interface (300 and 1200 bps), battery power, shirt pocket size, and a tiny price.

In fact, the WorldPort modems are the ultimate for both portable and desktop applications. And the WorldPort 2400 comes with Carbon Copy PLUS™ communications software, for even greater value.

If you want a modem that works where you do, put the WorldPort Series to work for you. In

the office. On the road. Or at home. For more information about our full line of WorldPort modems, or the name of your nearest dealer, call us at 800-541-0345. (In New York, 516-261-0423.)



Touchbase Systems, Inc.
160 Laurel Avenue
Northport, NY 11768
(516) 261-0423
TELEX: 6502848020
FAX: (516) 754-3491

WorldPort 2400 is a trademark of Touchbase Systems, Inc. Carbon Copy PLUS is a trademark of Meridian Technology, Inc.

THE COMPUSTAR[®] THEORY OF SENSIBILITY

$$C = at + mca^2 + eisa$$

Okay, we admit it may not be as profound as Einstein's Theory of Relativity. But, if you're a computer user, we bet it's a bit more, shall we say, "relative" — not to mention a whole lot more sensible.

The "C" stands for CompuStar[®] — the world's first and only multi-processor, convertible bus[™] microcomputer. And, as the theory states, CompuStar means AT, MCA and EISA compatibility — all in a single system.

A CONVERTIBLE BUS?

Each CompuStar features snap-in bus "modules" that let you convert from one bus standard to another — a PC/AT¹ bus, a PS/2 (MCA) bus. . . or both!

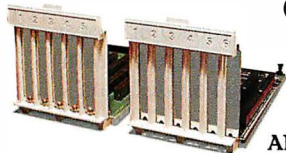

SNAP-IN PS/2
AND AT BUS MODULES.

Depending on configuration, you can have up to 13 AT and/or PS/2 bus expansion slots. Plus, when the new EISA bus becomes popular, we're licensed to offer it as well.

THREE COMPUTERS IN ONE.

Busess are not the only thing you can reconfigure in a CompuStar. Each system can be equipped with any of three CPU Modules — an 8086, an 80286 or an 80386. Since the modules are interchangeable, you won't have to worry about buying the *wrong* computer system. We'll even let you trade-in your CPU Module toward the purchase of any of



the other more powerful modules.* But that's not all. CompuStar features an incredible seven disk/tape compartments that we'll gladly custom configure for you at the factory. No matter what your application, we can tailor fit a CompuStar to match it precisely.

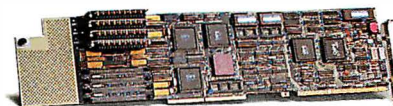

CPU MODULES ARE INTERCHANGEABLE.

IT'S NUMBER ONE RATED.

If you're thinking a computer with as much flexibility as CompuStar would have to compromise *something*, like performance — think again. With a MIPS³ rating of 6.1, the CompuStar is one of the fastest, most powerful systems available. In fact, CompuStar's performance and flexibility so impressed *InfoWorld* magazine they gave it the highest rating of all hardware products tested in 1988! That's astonishing when you consider you can buy a CompuStar for *thousands* of dollars *less* than a comparably equipped system from IBM or Compaq.

If you're shopping for the next generation in personal computers, why not call us today at 803/796-7800 to arrange an on-site no obligation 30 day CompuStar[®] trial in your office.* Relatively speaking, it's the only *sensible* thing to do.



Wells American

Circle 286 on Reader Service Card

Corporate Headquarters: 3243 Sunset Boulevard • West Columbia, SC 29169 • 803/796-7800 • FAX 803/796-7029

¹Personal Computer AT, AT, PS/2 and IBM are trademarks of International Business Machines Corporation. ²MCA is a trademark of IBM. ³Power Meter Version 1.2 (80386 25MHz model)
*Some restrictions may apply. Call us for details on our trade-in and total customer satisfaction programs.

NANOBYTES

SPARC processors from multiple vendors. Founding members of SPARC International include the manufacturers of the SPARC processor: Bipolar Integrated Technology, Fujitsu Microelectronics, LSI Logic, Cypress, and Texas Instruments.

Texas Instruments (Houston) has cranked up the speed of its **TMS34010** graphics processor to **60 MHz**. The original has a clock rate of 40 MHz. The new chips are \$76 each when you buy 10,000.

Intel said it will buy **Sun386i** systems for its circuit designers to use in developing "new generations" of ICs. Sun's 386i is a Unix system (with a DOS compatibility box) based on Intel's 80386 chip.

In what the company called "an incitement of guerrilla warfare,"

continued

with the progress of the Open Software Foundation (OSF) and will support the OSF/Motif graphical user interface being developed for Unix by Microsoft, Hewlett-Packard, and DEC.

Lautenbach emphasized that IBM views its Unix implementation, AIX, and its Systems Application Architecture (SAA) as two equally important "strategic platforms" for its customers. SAA will be the standard framework for IBM's proprietary operating systems, VM, MVS, AS/400, and OS/2. AIX will be the platform for IBM's products in the open architecture of the Unix environment. IBM will provide connectivity between AIX workstations and

SAA hosts and, if customers demand them, applications that run under both SAA and AIX.

IBM's enthusiasm for the Motif graphical interface raises the question of how IBM will use the NextStep user interface it has licensed from NeXT. It's unlikely that IBM will support two different and incompatible user interfaces on its Unix platform. It's reasonable, however, that IBM will use some of the NextStep technology, such as its development toolkit and object-oriented programming features. Many analysts have said that IBM hedged its bets when it licensed NextStep, just in case OSF fell apart and there was no other pictorial user interface that IBM could adopt.

Chip Makers Preview Memory Technologies

Fatter and faster memory technologies dominated this year's International Solid-State Circuits Conference in New York, where chip makers described advances in memory tech-

nology that will affect future personal computers and workstations.

Three Japanese companies revealed laboratory prototypes of the

continued

Microstat-II Can Save You Time and Money

Whether for industry, education, government, or pure research, no other statistics package can compare to Microstat-II in areas of coverage, accuracy, ease of use, and value. Just some of Microstat-II's features include

- Descriptive statistics (mean, standard deviation, variance, kurtosis, skewness, etc.)
- Regression Analysis: Simple, Multiple, Stepwise Multiple, forward and backward
- Cluster Analysis
- Canonical Correlation
- Correlation Analysis: matrix and cross products table
- ANOVA: Oneway, Twoway, Twoway with replicate
- LSD, Duncan's, Tukey, Newman-Keuls
- Crosstabs and Chi-square
- Hypothesis tests: mean or proportion
- Nonparametrics: Wald-Wolfowitz, Kruskal-Wallis, Wilcoxon, etc.
- Time Series: moving average, centered moving average, deseasonalization, exponential smoothing
- Probability Distributions: Normal, t, F, Poisson, etc.
- Frequency Distributions: value or range.
- Scatterplots (with simple regression)
- Factorials, Permutations, Combinations
- Up to eight times faster than the competition without loss of accuracy
- Online help plus easy to use keyboard or mouse input; no complex command language to learn
- Unequal cases, missing data, and aliased data, range checking
- Easy to use data entry system with file import capability
- Not copy protected
- Expanded user's manual

Requires an IBM PC, XT, AT, PS2 or compatible with 512K of memory 2 floppy disks or a hard drive. Price: \$395.00 with 30 day money back guarantee. Demo available for \$19.95. Please include \$4.00 for shipping. For information, call or write:

Orders: 1-800-952-0472

Technical Questions: 1-317-255-6476

FAX: 1-317-251-4604

Ecosoft Inc.

6413 N. College Ave.

Indianapolis, IN 46220



ECOSOFT



"Remote access to my PCs!"

"Ashton-Tate, Borland, IBM, Lotus, Microrim, Novell and 3Com all use Close-Up for their remote support. And now I know why. What a powerful management tool!"

It's true. Every major hardware and software manufacturer that offers remote services and support uses Close-Up.® Here's why. Close-Up gives you versatility, ease of use and reliability. It lets you work in tandem with your associates, share their screen and keyboard, access their DOS and run programs on their computer, *all remotely*. Business solutions. Just imagine the possibilities.

Customer Support

Take IBM for example. Our agreement covers over 100,000 copies of Close-Up for their support centers. Now IBM personnel can use their PCs to dial a customer's PC and be connected to their mini or mainframe. Linking

screens and keyboards as one unit. IBM and their customers can now diagnose problems together. *Simultaneously*.

Remote Order Entry

Novell uses Close-Up for its entire North American order/entry system. Their regional offices can call into any one of the 45 central office workstations running Close-Up and become part of Novell's order entry network. With file server access at full network speeds, 24 hours a day. And, using our print feature, reports are printed *remotely* at the regional sites.

Franchise Training & Support

Companies like Computerland, Kwik Kopy and PIP are opening new stores all the time. With Close-Up, they are able to train new employees, set up operating procedures, and monitor results instantly from their corporate offices. In fact, Computerland supports its large dealer network by using Close-Up with its Store Management System.

Point of Sale

Softsel uses Close-Up exclusively for their new Dial-Up SalesNet order/entry inventory system. They like Close-Up's error-corrected keystrokes and screens, ensuring that orders are entered accurately. Dealers can call in from around the country to check current inventory levels and review product/price descriptions. With ease.

Close-Up works at night ... so you don't have to.

Close-Up automates routine jobs day or night. Imagine an automated inventory and sales data system that calls all your offices, say 25 of them, each night (when phone costs are down). Back at your home office, Close-Up will run the inventory spreadsheet with a macro to consolidate the information. Close-Up then sends back the accumulated data. Even printing it out at each location for morning meetings. All this, while you sleep.

Join the Leaders

Close-Up is the clear choice of Fortune 500 companies and for compelling reasons. Why? Close-Up is quite simply more versatile, easier to use, and more reliable than any remote software on the market. Call us for an even closer look into:

- ▶ Remote Support ▶ Remote Order Entry
- ▶ Home to Office Communications ▶ PC to PC Communications ▶ PC to Mini or Mainframe
- ▶ PC to Information, Telex, & Electronic Mail Services ▶ Automated Communications
- ▶ Gateway to LANs

Call: 805/964-6767

Norton-Lambert®

PO Box 4085, Santa Barbara, CA 93140 USA
Telex 709170

Copyright Norton-Lambert Corp. 1988 IBM/PC/XT/AT, PS/2 and Compatibles

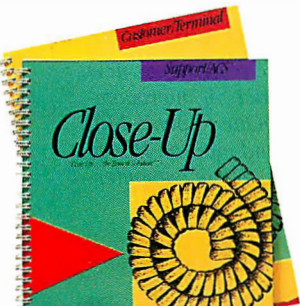

Circle 312 on Reader Service Card

NANOBYTES

Advanced Logic Research (ALR) (Irvine, CA) **reduced the prices** of some of its 80386-based systems. Most significantly reduced was a 25-MHz 80386 model that will now sell for less than \$3495. The price reductions are aimed primarily at the Flex-Cache line. In BYTE Lab tests, FlexCache systems rank among the fastest. The 20-MHz 386/220 is now probably the industry's first 80386-based system to sell for less than \$2000.

When **ALR** introduced its Micro-Flex 7000 Micro Channel clone last year, company officials told us the system would boast a 64-bit memory bus. Because of problems with some application software, however, the company had to redesign the computer to use a 64-bit bus only between the system's cache and main memory. Almost all other 80386 systems use a 32-bit bus. The increased width of the 64-bit bus should allow the ALR system to have slightly higher performance than other 80386-based systems.

Addison-Wesley (Reading, MA) has revised the *Amiga Technical Reference Series* to include information on System software version 1.3 and all three Amiga models.

Is **copy protection** coming back in another form? **Rainbow Technologies** (Irvine, CA) says it will be supplying **Ashton-Tate** with its SentinelPro "hardware key" for use with dBASE and Framework. Ashton-Tate will use the devices, which have to be stuck into the computer's printer port for the software to run, in some international markets where piracy rules. An Ashton-Tate official cited the Middle East as a pirate-rife market lacking in protection for owners of copyrights.

Lego, maker of those ubiquitous plastic building blocks, has formally endowed MIT with the Lego Chair of Learning Research. Lego inventor **Seymour Papert** was appointed as the first holder of the chair, which is made entirely of Legos, natch.

much-anticipated 16-megabit DRAM chip. Toshiba took the spotlight with a fast, 45-ns CMOS chip that uses ultrafine 0.6-micron technology. NEC weighed in with a 55-ns chip that uses 0.55-micron technology. And Mitsubishi scientists described a 60-ns DRAM chip with 0.5-micron rules that uses 3.3 volts instead of the 5 V that most chips use.

Each of these chips could hold 2 megabytes of data. It will be some time before such chips appear, however. The industry is only now beginning to see sufficient quantities of 1-megabit chips. The 16-megabit chips, two generations removed from the 1-megabit chips, probably will not be available for two to three years.

Hitachi researchers said they've developed technology that could permit DRAMs to run on just 1.5 V, which would be a boon to battery-powered computers. Hitachi said a 16-megabit 1.5-V DRAM could run for 500 hours on eight batteries.

IBM said that it has developed a 5-ns 128K-bit static RAM chip, the fastest ever made for its size. The chip has a 6.5-ns first-access time and a 5-ns cycle time; combined with 32-bit data I/O capacity, it offers data bandwidth as high as 6.4 gigabytes per second, higher than any previous

SRAM chip of 64K bytes or larger.

Texas Instruments, Hitachi, and Toshiba all disclosed high-capacity 1-megabit SRAM chips that break the previous speed record for their size. TI and Toshiba's chips have access times of only 8 ns, while the Hitachi clocks in at 9 ns.

Toshiba scientists said that they have developed a 4-megabit EEPROM device by reducing the number of memory cell components. Texas Instruments announced a 256K-bit flash EEPROM that requires only a single 5-V power supply for program, erasure, and read operations. TI said the chip's cost and performance were comparable to dual-power-supply EEPROMS (those that require 12 V to program and erase and 5 V to read) but that its application would be cheaper since only a single power source is required. The company projects that 5-V flash EEPROMS will be a major nonvolatile memory technology in the 1990s.

TI representatives also described a new 1-megabit CMOS "BurstMode" EPROM that uses 1.4-micron technology and offers 20-ns access time. TI said the speed and cost of this chip will make it a viable alternative to caching architectures that use more expensive SRAM chips.

Nobel Winner: Computers Are Tools, Not Brains

Computers can never replicate the power of the human brain, Nobel Prize winner Arno Penzias told computer scientists at the Association for Computing Machinery's recent conference on computer science, but they "can do an awful lot for us" if we accept them "as a tool rather than as a replacement."

"I see computers as an engine, and that's a good term because computers are like automobiles," said Penzias, vice president of research at AT&T Bell Laboratories. "Computers help you an awful lot with speed but are almost useless in terms of charting direction."

Penzias, who shared a Nobel

Prize in 1979 for his work in radio waves relating to the birth of the universe, wants to link fax machines with computers and, of all things, file cabinets. Noting that 90 percent of all paper that is filed is never again retrieved because we can't find it, the physicist thinks we should be able to fax directly to a file cabinet and create at the same time a scanned image of the page that is converted to ASCII so it can be searched and then retrieved. Penzias also wants computer scientists to concentrate on machines that help people rather than work like people. "The real challenge is not to emulate human beings with machines, but to reinforce them," Penzias said.

TECHNOLOGY NEWS WANTED. *We're always interested in hearing about new technological and scientific developments that might have an impact on microcomputers and the people who use them. Contact the Microbytes staff at One Phoenix Mill Lane, Peterborough, NH 03458; phone us at (603) 924-9281; or send mail on BIX to Microbytes. An electronic version of Microbytes, offering a wider variety of computer-related news on a daily basis, is available on BIX and some BBSes.*

10 YEARS

2727 W. Glendale Ave., Phoenix, AZ 85051
 Phone Hours: Mon. thru Fri. 6:30 AM-9:00 PM MST
 Saturday 9:00 AM-5:00 PM MST
 Technical Support: 1-800-421-3135

EPSON LQ-950

40% OFF

- The LQ-950 combines SmartPark™ paper handling with 24-pin Letter Quality printing excellence.
- LQ-950's SelectType front control panel gives you push-button control of an array of impressive features.

Our Price **\$554***
 Sug. Retail \$949

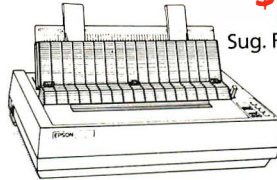

*Price is net of \$75 manufacturer's rebate good thru 5-31-89

We carry all Epson products at comparable savings.

EPSON FX-1050

- Wide-carriage 9-Pin Printer
- SmartPark™ a unique Epson paper-handling innovation
- The FX-1050 prints 264 CPS in high speed draft
- 54 CPS in near letter quality mode

40% OFF

Our Price **\$469**
 Sug. Retail \$799

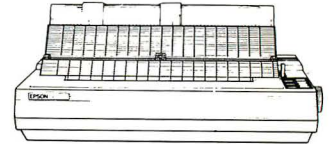

WAREHOUSE DATA PRODUCTS

TO ORDER IN THE U.S.A. & CANADA
1-800-421-3135
 We Welcome International Accounts
 Call Our Fax Line (602) 246-7805

EPSON LQ-1050 24-PIN PRINTER

45% OFF

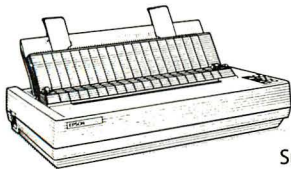

Our Price **\$679***
 Sug. Retail \$1199

*Price reflects manufacturer's rebate good thru 5-31-89

SOFTWARE

| | | | |
|-----------------------------------|------------------------------------|---|---|
| ACCOUNTING | INTEGRATED | LANGUAGES | UTILITIES |
| ACCPAC BPI \$234 | Enable OA \$352 | Flowchart II Plus \$142 | Allways \$40 |
| DacEasy Acct. 3.0 55 | Microsoft Works 83 | Microsoft C Compiler Ver. 5.1 295 | Copy II PC 19 |
| DacEasy Payroll 55 | BE 1st Choice 3.0 88 | MS Fortran Ver. 4.1 295 | Desktop Ver. 2.2 72 |
| Dollars & Sense 3.1 100 | Smart System 455 | MS Macro Assembler Ver. 5.1 98 | Fastback Plus 104 |
| Managing Your Money 5.0 117 | DESKTOP PUBLISHING | MS Quick Basic 4.5 65 | Formworks w/Fill & File 85 |
| Peachtree Complete 149 | Pagemaker Ver. 3.0 \$475 | MS/Quick C 65 | Graph in the Box 2 73 |
| Quicken 2.0 28 | PFS: First Publisher 2.0 73 | Turbo Basic 1.1 65 | Mace Gold 79 |
| DATA BASE MANAGERS | Ventura Publisher 2.0 449 | Turbo C Ver. 2.0 90 | Microsoft Windows 286 Ver. 2.1 65 |
| Clipper \$410 | COMMUNICATIONS | Turbo Pascal 5.0 93 | Norton Advanced 4.5 75 |
| Data Perfect 283 | Carbon Copy Plus \$105 | SPREADSHEET | PC Tools Deluxe 37 |
| DBase IV 463 | PC Anywhere III 69 | Lotus 1-2-3 w/Allways \$289 | Sidekick Plus 120 |
| DBase IV Developers Ed. 799 | Procomm Plus 42 | Lucid 3D 79 | Timeslips III 113 |
| DB-XL Diamond 115 | PROJECT MANAGER | Quattro 156 | CAD/GRAPHICS |
| Fox Base Plus 2.1 190 | Timeline Ver. 3.0 \$364 | Plan Perfect 189 | Design Cad 2D & 3D \$148 |
| Paradox 3.0 435 | Harvard Total Proj. Mgr. 369 | WORD PROCESSING | Generic Cad Level 3 133 |
| PFS: Profile 165 | MULTI-USER SOFTWARE | Grammatik III \$49 | Grasp 79 |
| Q&A 3.0 215 | FoxBase \$299 | SP/PC 165 | Harvard Graphics Ver. 2.1 265 |
| Quicksilver Diamond 329 | Microsoft Word 205 | Word Perfect Ver. 5.0 219 | PFS: First Pub. Ver. 2.0 73 |
| Revelation Advanced 460 | Word Perfect 339 | Word Perfect Library Ver. 2.0 65 | Printshop 33 |
| RBase for DOS 425 | | Wordstar Pro 5.0 239 | Showpartner F.X. 199 |

HARDWARE

| | | | |
|--------------------------------|--------------------------------|-------------------------------|-----------------------------------|
| COMPUTERS | HARD CARDS | LOGITECH | INTEL |
| ARC Pro Turbo 286 Call | Plus 20 MB \$519 | Clear \$63 | Above 286 Plus 416 |
| ACER | Plus 40 MB 649 | HiRes 73 | Above 286 I/O 469 |
| 710 w/o Monitor \$785 | HARD DRIVES | PS/2 57 | Connection Co-Processor 739 |
| 900 w/o Monitor 1199 | SEAGATE | PRINTERS | ORCHID |
| AT&T | ST-225 20MB w/cont \$259 | CITIZEN | Ram Quest Extra PS/2 339 |
| 6285 WGS 1499 | ST-238 30 MB w/cont 279 | 120D \$146 | Tiny Turbo 289 |
| 6300 WGS 899 | 40 MB AT 251 349 | OKIDATA | MODEMS |
| 6386 WGS, 40MB H.D. 2999 | MONITORS | OKI 320 359 | EVEREX |
| TOSHIBA LAPTOPS | Amdek 410 \$145 | OKI 390 499 | 300/1200 w/Soft \$69 |
| T 1200 FB \$1569 | Mitsubishi Diamond \$45 | PANASONIC | 2400 EXT. Error Cor. 189 |
| T 1200 HB 2419 | Princeton Max 15 249 | 1180 339 | HAYES |
| T 1600 3359 | Princeton Ultrasync 509 | STAR MICRONICS | 1200B INT w/Soft 289 |
| T 3100 E 2839 | Samsung Ultrasync 89 | NX 1000 179 | US ROBOTICS |
| TS200 140 6389 | Samsung Amber Flat 89 | NX 1000 Color 238 | 2400w/o Soft 335 |
| VGA/EGA BOARDS | Samsung RGB 249 | BOARDS | ACCESSORIES |
| ATI EGA Wonder B00 \$229 | Samsung EGA 369 | AST | Copy II PC Deluxe Bd \$101 |
| ATI VGA Wonder 312 | Samsung Multisync 449 | Rampage 286 Plus \$509 | Curtis Ruby 69 |
| Orchid Pro Designer 299 | Zenith 1490 599 | EVEREX | Logical Connection 512K 532 |
| Paradise VGA Prof 485 | MICE/SCANNERS | 2MB Above PC/XT 79 | Masterpiece + 95 |
| Vega V-RAM 485 | Complete Scanners \$149 | 3MB Above AT w/o Mem 89 | 150 Watt Power Supply 69 |

Lasers

Best Prices on ALL Laser Printers!

We carry a complete line of the most popular printers on the market today.

Call us Today

Toll-Free 1-800-421-3135.

USER FRIENDLY TERMS & CONDITIONS:

We welcome international accounts, please call for special pricing. Volume discounts for corporate and institutional orders. We do not charge your credit card until your order is shipped. Shipping minimum is \$5.00. Arizona orders + 6.7% sales tax. Personal/company checks allow fourteen (14) days to clear.

BY05

- All shipments insured at no extra cost.
- All prices are subject to change without notice.
- We do not guarantee compatibility.
- All trademarks are registered.



CALL FOR ITEMS NOT SHOWN
1-800-421-3135



DADiSP..

Let Your Instruments
Do The Talking.™



Talk to your instruments with **DADiSP-488**. Use over 150 functions to display and analyze your waveforms, as easy as typing a name. Run external data acquisition software, or *your own analysis programs*. Create new functions with *DADiSP Macros*.



the First Spreadsheet
designed exclusively for
Scientists and Engineers.

(617) 577-1133

Ask about DADiSP for IBM-PC/XT/AT, DEC MicroVAX, HP9000, Masscomp 5000, and Sun Workstations. For further information write DSP Development Corporation, One Kendall Square, Cambridge, MA 02139, (617) 577-1133

Mention this magazine and receive an Evaluation Disk FREE. A \$20 value.



LETTERS

and Ask *BYTE*

It's a Plot

The Product Focus entitled "Plotters in Perspective" by Stanford Diehl and Steve Apiki (December 1988) was interesting, but I would like to make a few comments.

First, the article should have included data on overshoot. Under some conditions, even a small amount of this can be very annoying.

Also, I believe the term "friction roller" is inaccurate. From what I have read, a grit-covered wheel first makes an indented pattern in the paper. Later travel falls into the same pattern; otherwise, the paper would eventually lose registration.

Finally, why are the prices so high? Even the lowest-cost unit is nearly \$800. Surely American industry can do better, or is everything going to end up being built overseas?

Frank J. Wilson
Tomasles, CA

Wall Street Raider Update

I always enjoy Jerry Pournelle's column in *BYTE*, and I particularly enjoyed the January column, since Jerry had some nice things to say about my corporate takeover/stock market simulation, *Wall Street Raider*. However, I should point out that he was reviewing a copy that my former software publisher, Oasis Press, sent him way back in 1986.

Oasis Press, which has moved to Oregon, still sells the program but no longer publishes it. The current publisher of *Wall Street Raider* is Intracorp Software (14160 Southwest 139th Court, Miami,

WE WANT TO HEAR FROM YOU. Please double-space your letter on one side of the page and include your name and address. We can print listings and tables along with a letter if they are short and legible. Address correspondence to Letters Editor, *BYTE*, One Phoenix Mill Lane, Peterborough, NH 03458.

Because of space limitations, we reserve the right to edit letters. Generally, it takes four months from the time we receive a letter until we publish it.

FL 33186, (800) 468-7226). The program costs \$34.95.

Michael D. Jenkins
Alameda, CA

I'll Stick with IntegrAda

I think the review of IntegrAda by Karl Nyberg and Jon Udell (January) grossly misrepresents the product. I bought IntegrAda a couple of months ago, and I love it. It is a Stoneman-like environment surrounding a validated Ada compiler that runs very well on my home microcomputer. It's easy to use, and I have had few problems with it (and most of those were my own fault). And it cost me just \$500. I actually prefer it to the multi-thousand-dollar products available to me at my workplace.

Nyberg and Udell stated that they used version 4.0. I have version 4.0.1. I have to believe that most of the reviewers' negative comments are based on the older version, because so many of the faults they point out are nonexistent on my version. Other perceived "faults" seem to be based on a comparison of IntegrAda with products that cost much, much more.

Dan Keller
Huntington Beach, CA

Algorithm Optimizing

I recently noticed a massive speedup of the Sieve of Eratosthenes, one of your language benchmarks. In this algorithm, the idea is to initialize a set of flags, then repeatedly increment a pointer from 1 to an upper limit until it indexes an initialized flag. This, then, is a prime number, so all multiples within range (except itself) have their associated flag cleared. The process then continues so that, at the end, any untouched flag indicates a prime index. But all the multiples of any prime n between itself and n^2 will have been crossed off already because they are of the form $(n \times m)$ where $2 \leq m \leq n-1$, and multiples of all these m have been crossed off already! Therefore, you need only start searching/crossing off at n^2 rather than $2 \times n$, and you need only

continued

Leader of the Mac!



The Experts Agree:

FoxBASE + /Mac's New Version 1.10 is the Ultimate Relational Database Management System for the Macintosh!

Don Crabb, *InfoWorld*, July 11, 1988:

"FoxBASE+ /Mac proved to be as easy to use as any Mac relational database we've tested."

Macworld, September, 1988:

"FoxBASE+ /Mac deserves serious consideration as both a stand-alone database product and a connectivity solution."

Richard Skrinde, *MacUser*, September, 1988:

"FoxBASE+ /Mac is a racehorse that will outrun the other Macintosh databases."

Arthur Fuller, *Computing Canada*, June 9, 1988:

"So phenomenally great that it justifies the purchase of a Macintosh just to run it!"

Michael Masterson, *MacWEEK*, June 7, 1988:

"FoxBASE+ /Mac proves beyond a doubt that the Mac is a suitable platform for supporting fast database operations."

BYTE, September, 1988:

"FoxBASE+ /Mac combines dBASE compatibility with a strong list of features and a work environment with which Mac users will feel comfortable."

Charles Seiter, *Macworld*, October, 1988:

"It's the fastest general purpose Mac database, often ten to a hundred times faster than its competitors."

FoxBASE+ /Mac Version 1.10 includes everything you love about the original FoxBASE+ /Mac PLUS a new form generator, an outstanding application generator and a complete template language system — all designed to save you time and effort! Now you can develop complete database applications in just minutes!

And now Fox Software introduces FoxBASE+ /Mac Multi-User, leading the industry with the ultimate in data sharing — *concurrent data access!* For the first time, networked Macs and PCs can simultaneously share the same data files!* In addition, FoxBASE+ /Mac Multi-User supports an unlimited number of users on your network.

Even with all these enhancements, Version 1.10 doesn't cost any more — it's still only \$395! And our new Multi-User is just \$595!

FoxBASE+ /Mac earned an exceptional 7.0 rating on *InfoWorld's* Software Review, and a 4.5 rating on *MacUser's* scale. It's the one Mac database system that has it all!

Join the experts NOW! Contact your local quality software dealer, or order your copy of FoxBASE+ /Mac by calling (419) 874-0162, Ext. 320. Free demo package available.

Why be a follower when you can go with the *leader!*

Fox Software

Nothing Runs Like a Fox.

Fox Software
118 W. South Boundary
Perrysburg, OH 43551

(419) 874-0162, Ext. 320.
FAX: (419) 874-8678
TELEX: 6503040827 FOX

* Requires a copy of FoxBASE+ /LAN, our PC multi-user software, on the network file server. FoxBASE+ /Mac and FoxBASE+ /Mac Multi-User are trademarks of Fox Software. dBASE is a trademark of Ashton-Tate. Macintosh is a trademark of Apple Computer, Inc.

Circle 108 on Reader Service Card

MAY 1989 • BYTE 25



A Brand New Resolution The Handy Scanner HS-3000

Free HALO DPE™

The handiest little scanner in the world just got even better. The Handy Scanner 3000 (now DPE) offers you clarity and versatility in a little package. Like our other Handy Scanners, the Handy Scanner 3000 for the IBM PC, PS/2s and compatibles can handle almost all the jobs the desktop mislels can, but it's smaller and easier to use.

We give you the features you need the most in a Handy Scanner. The new 4-1/8" scanning width makes short work of the biggest pictures. You can switch the scanner between 400/300/200/100 DPI. For those really important pictures, the Handy Scanner 3000 lets you have it all with 400 DPI resolution. The real-time screen display lets you instantly see your scan, so you can quickly make scanner adjustments as necessary. With adjustable halftones and contrast, you get a clean, clear picture. Two col-

ors, such as red or reddish skin tones can be scanned without losing detail.

The Handy Scanner 3000 comes complete with full-featured, powerful software for scanning, editing, and merging text with your graphics. Saved scan files are compatible with almost all graphic software, including PageMaker, Ventura, WordPerfect 5.0, and many others. The package includes the scanner, interface card, the HALO DPE (the publishing software package worth \$195), a utility diskette and an instruction manual.

The Handy Scanner 3000 is a little scanner that does a lot, and now it does it even better.

\$299.95

ADDED SPECIAL NOW OCR SOFTWARE AVAILABLE

Converts scanned images from scanner into ASCII text for use with word processors, data bases, etc.

Reg. \$199.95
if purchased with HS-3000 ONLY

\$79.95

LOGITECH SCANMAN

- 200 dpi
- 4" scanning width
- IBM, PC, XT, AT, PS/2 (25 & 30)



Complete with Logitech™ "Scanware"™ Software

\$189.95

QUALITY CUSTOMER SERVICE 508-278-6555

TECHNICAL ASSISTANCE 508-278-6556



TOLL FREE ORDER LINE
1-800-635-0300

TRUE DATA PRODUCTS

115 MAIN ST., P.O. BOX 347
UXBRIDGE, MA 01569
508-278-6555

HOURS: MON-FRI. 9-6, SAT. 10-4 (EST)

CORPORATE P.O.'S WELCOMED

ALL PACKAGES SHIPPED UPS EXCEPT CANADA AND A.P.O.'S

C.O.D.'S ADD \$2.30

MASTER CHARGE/VISA ADD 3%

1 YEAR WARRANTY UNLESS OTHERWISE NOTED

PRICES TERMS CONDITIONS SUBJECT TO CHANGE WITHOUT NOTICE

LETTERS

search up to the square root of your upper limit (if max = 8192, you need only search up to $n = 90$).

So, in BASIC:

```
max=8192 : root=90 : DIM flags(max)
FOR num=1 TO max : flags(num)=TRUE :
NEXT num
FOR num=2 TO root : IF flags
(num) THEN
FOR mult=num*num TO max STEP num:
flags(mult)=FALSE : NEXT
END IF : NEXT num
```

The chance to fake benchmarks semi-legitimately comes up yet again. But the real question is, How long will it be before an "optimizing compiler" can find speedups like this? Or is there a mass market for "algorithm optimizers"?

Nick Pelling
Hornchurch, Essex, U.K.

News Brief

The January Microbyte entitled "Japanese Giants Offer New Unix Systems" announces Sony's new Unix workstations and attributes "NeWS" to the name of this line of hardware. The name "news" is indeed correct, but, in fact, "NeWS," as printed, is the trademark of Sun Microsystems' network-based graphical windowing system.

Your attention to these details is important and appreciated.

Stacey M. Cannon
Sun Microsystems, Inc.
Billerica, MA

More on Bridges

"When One LAN Is Not Enough" by William Stallings (January) successfully shed light on many important aspects of internetworking. However, the author made several misleading statements and omissions with regard to bridges. Bridges can have considerably more functionality than the article discusses, and readers should understand all that current bridge products have to offer when evaluating internetworking options.

First, bridges do not depend on upper-layer protocols (ISO layers 3 to 7). Upper-layer protocol independency is a characteristic of bridges, routers, and gateways, and it makes bridges the most flexible internetworking solution available. Bridges do not assume anything about any upper-layer protocols. In some cases, they do not even depend on lower-layer protocols. For example, an IEEE 802.5 token-ring bridge will bridge two networks that follow the IEEE 802.5

continued

Call us for a free AnthroCart catalog: **800-325-3841**





Anthro® Technology Furniture®

3221 N.W. Yeon St.
Portland, Oregon 97210
(503) 241-7113

Anthro, AnthroCart and Technology Furniture are registered trademarks of Anthro.

PC EXPERTS AGREE:



Proteus® offers the fastest for the least, and supports them the most.

Proteus® sells the fastest personal computers you'll find. But as experts from BYTE, InfoWorld, Personal Computing, and others have discovered, our computers are more than just fast.

"The Proteus is an excellent value for the performance it offers potential buyers. Its speed, expansion capability, and service contract put it in a class with the big boys."

Personal Computing Magazine

"You get... fifteen months of service coverage – and onsite at that. Even without the warranty, we highly recommend this machine."

Computer Buyers Guide

"A remarkable range of performance and operational capabilities."

BYTE Magazine

For the fastest, most economical, best supported computers available, follow the experts to Proteus.

"This IBM-compatible is so fast I have had trouble measuring its speed."

Business Computer Digest

"Proteus is markedly faster than any other personal computer we've worked with, including Deskpro 386/20."

Personal Computing Magazine

"The Proteus is one of the fastest desktop computer systems we tested, a zero-wait-state hot rod."

InfoWorld Magazine

"... a complete multi-user solution that arrives with all peripherals and operating systems installed and tested... a very powerful machine that does what it claims."

Computer Shopper Magazine

PROTEUS 286-16

16MHz, ZERO WAIT STATE

- 80386 CPU running at 16MHz
- 640K RAM
- 8 expansion slots
- 5 drive bays
- 2 serial & 1 parallel port
- 1:1 interleave
- Hard disk & floppy controller
- 200W power supply
- 101-key enhanced keyboard
- 15-month on-site service free
- Made in U.S.A. **\$1,495**

COMPLETE SYSTEMS:

- Monochrome System \$1,656
- EGA Color Plus System \$2,112
- VGA 16-bit 800x600 System \$2,407



PROTEUS 386-20

20MHz, ZERO WAIT STATE

- Intel 80386 CPU at 16MHz
- Optional 80386-20MHz
- 1MB RAM – Expandable to 16MB
- Intel 82385 EE cache ctr
- 32K fast cache
- 2 serial & 1 parallel port
- 1.2MB floppy drive
- Dual HD & floppy controller
- 1:1 interleave
- 200W power supply, 110/220V
- 101 key tactile keyboard
- 15-month free on-site service
- Made in U.S.A. **\$2,695**

COMPLETE SYSTEMS:

- Monochrome System \$2,939
- EGA Color Plus System \$3,495
- VGA 16-bit 800x600 System \$3,790



PROTEUS 386-25

25MHz, ZERO WAIT STATE

- Intel 80386 CPU at 25MHz
- 1MB RAM expandable to 16MB
- Intel 82385EE cache ctr
- 32K fast cache
- 387 coprocessor support
- 2 serial & 1 parallel port
- Dual HD & floppy controller
- 1:1 interleave
- 200W power supply, 110/220V
- 1.2MB floppy drive
- 101 key tactile keyboard
- 15-month free on-site service
- Made in U.S.A. **\$3,995**

COMPLETE SYSTEMS:

- Monochrome System \$4,021
- EGA Color Plus System \$4,667
- VGA 16-bit 800x600 Multiscan System \$4,962



PROTEUS SYSTEM 3400ME UNIX & DOS

MULTIUSER SYSTEM

- 80386-25 CPU, 25 MHz opt. 33 MHz
- 8-User system support
- 4MB 32-bit RAM
- Intel 82385 ctr
- Cache Memory
- 150MB ESDI fast hard disk
- 1.2MB 5.25" or 3.5" 1.44MB fd
- Upright server Case, 8 drive bays
- 250W 110/220v power supply
- SCO XENIX/PC MOS operating sys.
- High res. 14" console/monitor
- Graphics controller
- Parallel & serial ports
- 15-month free on-site service
- **COMPLETE SYSTEM: \$8,795**
- Choice of optional terminals & Proteus Lightwave graphics term.



To order, call us direct. 1-800-782-8387 In N.J. call 201-614-7000

For 24 hr catalog, call 1-800-548-5036 using your modem set at 1200B or 2400B/N/8/1.

Technical Support Hotline: 1-800-541-8933 Reseller/VAR programs available.

Custom configurations available.

All trademarks recognized. © Proteus is a registered trademark of Proteus Technology Corp. All prices, terms, specs subject to change.

proteus
THE INTELLIGENT CONCLUSION
75 Kingsland Ave.,
Clifton, N.J. 07014

As your introduction to
The Library of Computer
and Information Sciences...

Take Any 3 Books

(Publishers' prices shown)

PROFESSIONAL TOOLS

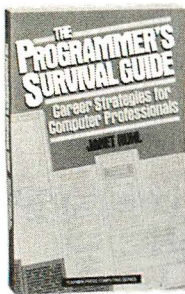

70810 \$16.95

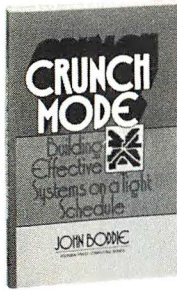

41254 \$29.00

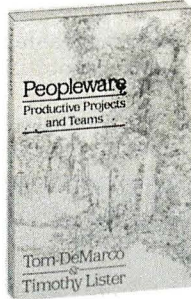

67818 \$23.00

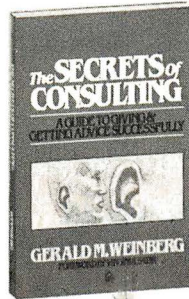

77620 \$25.00

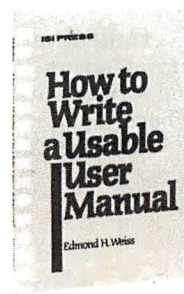

53920 \$14.95

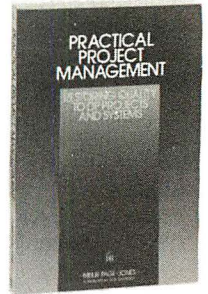

69930 \$28.00

SOFTWARE DEVELOPMENT/SYSTEMS DESIGN

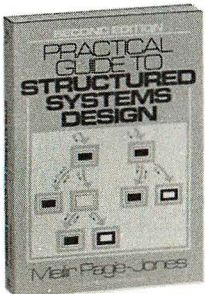

69939 \$35.00



52342-2 \$39.95
(Counts as 2 choices)

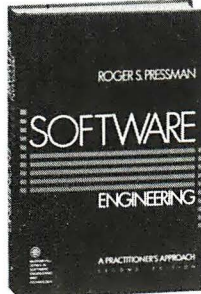

79162-2 \$44.95
(Counts as 2 choices)

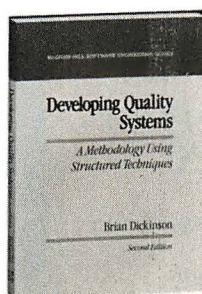

42061-2 \$39.95
(Counts as 2 choices)

ARTIFICIAL INTELLIGENCE

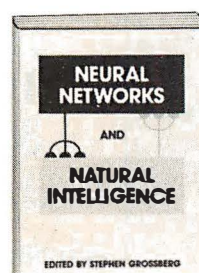

64019 \$35.00

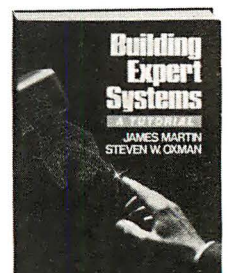

36972-2 \$48.00
(Counts as 2 choices)

COMPUTER SCIENCE

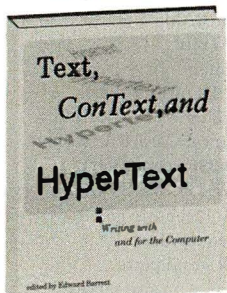

82841 \$35.00

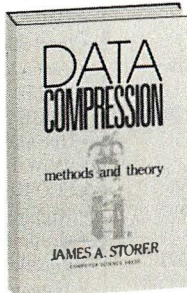

41649-2 \$44.95
(Counts as 2 choices)

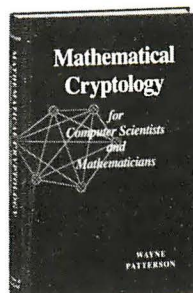

61000-2 \$37.50
(Counts as 2 choices)

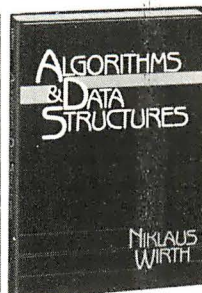

32490-2 \$37.33
(Counts as 2 choices)

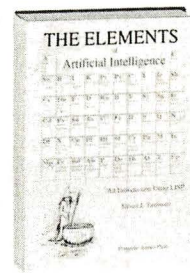

44177-2 \$35.95
(Counts as 2 choices)

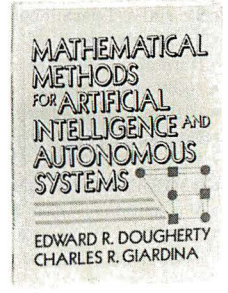

61314-2 \$55.00
(Counts as 2 choices)

COMMUNICATIONS

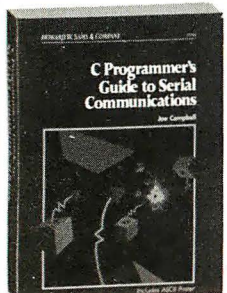

37173 \$22.95

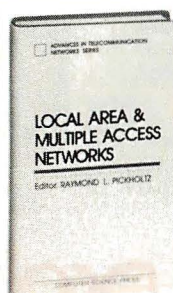

58751-2 \$40.00
(Counts as 2 choices)

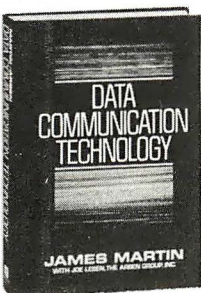

41648-2 \$49.00
(Counts as 2 choices)

OPERATING SYSTEMS

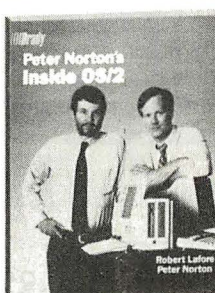

68428 \$24.95

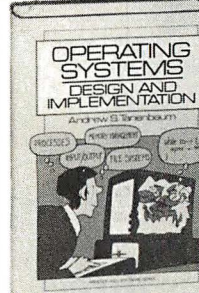

66004-2 \$46.00
(Counts as 2 choices)



66006-2 \$48.00
(Counts as 2 choices)

The Library of Computer and Information Sciences

Call 1-800-777-1146 to join now!

Please accept my application for trial membership and send me the three volumes indicated, billing me only \$1.00 each, plus shipping and handling. I agree to purchase at least three additional Selections or Alternates over the next 12 months. Savings range up to 30% and occasionally even more. My membership is cancelable any time after I buy these three additional books. A shipping and handling charge is added to all shipments.

No-Risk Guarantee: If I am not satisfied—for any reason—I may return my introductory books within 10 days. My membership will be canceled, and I will owe nothing.

3 books for \$1.00 each:

| | | |
|--|--|--|
| | | |
|--|--|--|

Indicate by number the books you want. A few expensive books (as noted) count as more than one choice.

Name _____

Firm _____
(If you want subscription sent to your office)

Address _____ Apt. _____

City _____

State _____ Zip _____

(Books purchased for professional purposes may be a tax-deductible expense. Offer good in Continental U.S. and Canada only. Prices slightly higher in Canada.)

7-FF9

BYTE 5/89

The Library of Computer and Information Sciences

Call 1-800-777-1146 to join now!

Please accept my application for trial membership and send me the three volumes indicated, billing me only \$1.00 each, plus shipping and handling. I agree to purchase at least three additional Selections or Alternates over the next 12 months. Savings range up to 30% and occasionally even more. My membership is cancelable any time after I buy these three additional books. A shipping and handling charge is added to all shipments.

No-Risk Guarantee: If I am not satisfied—for any reason—I may return my introductory books within 10 days. My membership will be canceled, and I will owe nothing.

3 books for \$1.00 each:

| | | |
|--|--|--|
| | | |
|--|--|--|

Indicate by number the books you want. A few expensive books (as noted) count as more than one choice.

Name _____

Firm _____
(If you want subscription sent to your office)

Address _____ Apt. _____

City _____

State _____ Zip _____

(Books purchased for professional purposes may be a tax-deductible expense. Offer good in Continental U.S. and Canada only. Prices slightly higher in Canada.)

7-FF9

BYTE 5/89

10-Day
Free Examination!



BUSINESS REPLY MAIL
FIRST CLASS PERMIT NO. 230 RIVERSIDE, NJ

POSTAGE WILL BE PAID BY ADDRESSEE

NO POSTAGE
NECESSARY
IF MAILED
IN THE
UNITED STATES



**The Library of Computer
and Information Sciences**
Riverside, New Jersey 08075-9889



10-Day
Free Examination!



BUSINESS REPLY MAIL
FIRST CLASS PERMIT NO. 230 RIVERSIDE, NJ

POSTAGE WILL BE PAID BY ADDRESSEE

NO POSTAGE
NECESSARY
IF MAILED
IN THE
UNITED STATES

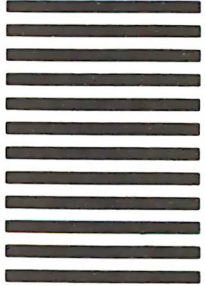

**The Library of Computer
and Information Sciences**
Riverside, New Jersey 08075-9889



For Only \$1.00 Each

values
to
\$105⁰⁰

You simply agree to buy 3 more books—at handsome discounts—within the next 12 months.

PROGRAMMING IN C

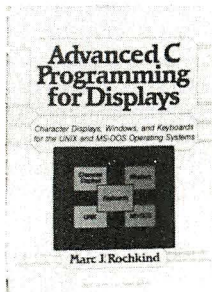

32274 \$32.95

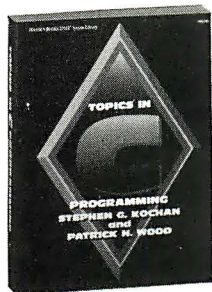

84408 \$24.95

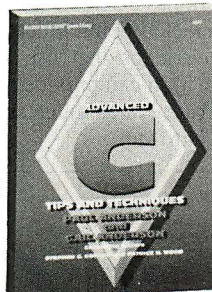

32273 \$24.95

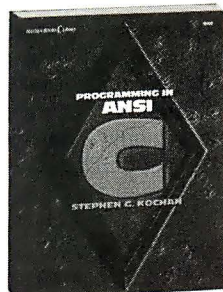

70674 \$24.95

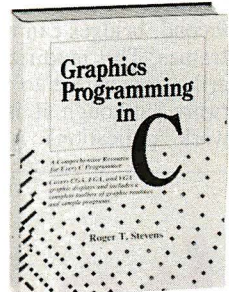

50565 \$24.95

MICROS

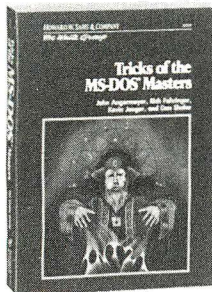

84741 \$24.95

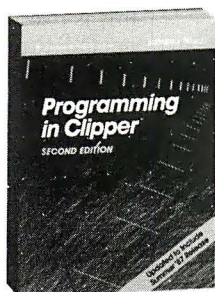

70686 \$32.95

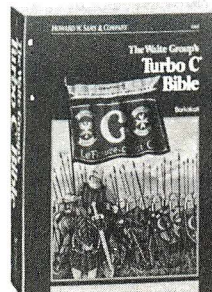

84839 \$24.95

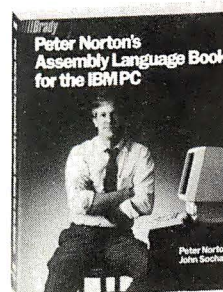

68427 \$21.95

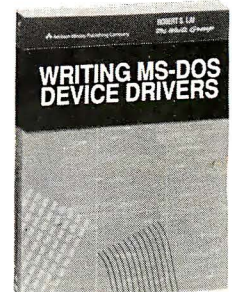

87958 \$24.95

UNIX



32288 \$29.95

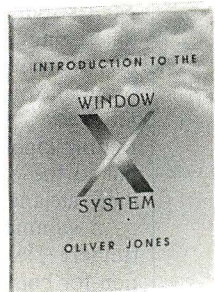

56530 \$32.00

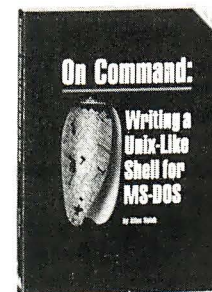

65326-2 \$39.95
(Counts as 2 choices)

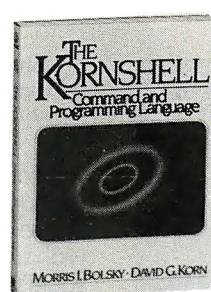

57390 \$26.00

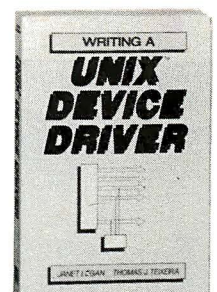

87727 \$24.95

4 Good Reasons to Join

1. The Finest Books. Of the hundreds of books submitted to us each year, only the very finest are selected and offered. Moreover, our books are always of equal quality to publishers' editions, *never* economy editions.

2. Big Savings. In addition to getting 3 books for only \$1.00 each when you join, you keep saving substantially, up to 30% and occasionally even more. (For example, your total savings as a trial member—including this introductory offer—can easily be over 50%. That's like getting every other book free!)

3. Bonus Books. Also, you will immediately become eligible to participate in our Bonus Book Plan, with savings of 65% off the publishers' prices.

4. Convenient Service. At 3-4 week intervals (16 times per year), you will receive the Library of Computer and Information Sciences News, describing the Main

Selection and Alternate Selections, together with a dated reply card. If you want the Main Selection, do nothing, and it will be sent to you automatically. If you prefer another selection, or no book at all, simply indicate your choice on the card and return it by the date specified. You will have at least 10 days to decide. If, because of late mail delivery of the News, you should receive a book you do not want, we guarantee return postage.

If reply card is missing, please write to The Library of Computer and Information Sciences, Dept. 7-FF9, Riverside, NJ 08075, for membership information and an application.

Call 1-800-777-1146 to join today!

Byte 5/89

MAY 1989 • BYTE 29

standard. These two networks can have any combination of NetBIOS, APPC, ISO, IEEE 802.2 LLC, or any other protocol running over IEEE 802.5. Applications using any of these protocols over IEEE 802.5 can communicate through this bridge.

Second, bridges can modify forwarded frames. This modification is not necessarily transparent to network system software, although it is transparent to network applications. A prime example

of this is source routing, often used in conjunction with IEEE 802.5. In source routing, all possible routes between two nodes are determined when the nodes begin communicating with each other. After the initial route has been determined, all frames between the two nodes carry the selected communication route with them. Bridges that use a source-routing algorithm can provide much better performance with a much smaller investment of hardware.

Third, ISO layer 2 (Data Link Control, or DLC) is further subdivided into two sublayers—Logical Link Control (LLC) and Media Access Control (MAC). Bridges can be implemented over either the DLC-MAC sublayer or over the physical layer (layer 1). Stallings's article discusses only the latter type of bridge. The major advantage of a bridge over the DLC-MAC layer is that it can support different physical mediums. For example, a 4-megabit-per-second token ring and a 16-megabit-per-second token ring could be bridged. As another example, a IEEE 802.5 token ring and an IEEE 802.3 Ethernet could be bridged. The latter bridge could use a source-routing algorithm on the token-ring side and a different bridging algorithm on the Ethernet side.

Fourth, bridges can be found between very dissimilar networks. An example of this is two LANs in different cities connected through a wide-area network (WAN). Layered protocols could be used in this situation. For example, to bridge two token-ring LANs over an X.25 WAN, a layered protocol of IEEE 802.2 LLC over X.25 might be used. No standards currently exist for layered protocols, although proprietary implementations can be found.

As an sample implementation, NCR's Financial Systems Division is developing an internetworking solution for token-ring LANs and X.25 or SDLC WANs using a proprietary layered protocol. NCR's solution can support both remote token rings and single remote workstations communicating through the same bridge. This bridge operates over the DLC-MAC sublayer and uses a source-routing algorithm to maximize throughput to the extent allowed by the WAN data rate and reliability.

In summary, bridges can be an extremely flexible internetworking solution for both similar and dissimilar networks. They do not require identical upper-layer protocols, and in some cases they don't even require similar lower-layer protocols. LANs and WANs can be internetworked transparently to network applications with throughput limited only by the data rate and reliability of the WAN.

Peter J. Kulik
NCR Corp.
Dayton, OH

Unstructured GOTO

I read "Trees 'n Keys" by Rick Grehan (January, February, and March) with interest, especially since I have some expe-

continued

the Telcor modem "simply ate up our data."

38.4K
bps



John H. Humphrey and Gary S. Smock
High Speed Modems
June 1988, Byte Magazine

you find that hard to believe, prove it to yourself. Order a pair at \$1195 apiece and try them for thirty days. High speed file transfer software for your PC-AT is included.

Call us toll free in the U.S. at 1-800-826-2938. Elsewhere call 1-508-653-3995. VISA and Mastercard accepted. Also available through local distributors.

**tel
cor** | TELCOR
SYSTEMS
CORPORATION

*the world's fastest
dial modems*

Our patented Model 2496 data compressing modem was the only 2400 bps unit included in this evaluation of 9600 bps dial modems. And it was judged the surprise of the lot!

Just imagine what our 9600 bps modem can do . . . dial data throughput up to 38,400 bps. What's more, the Telcor Model 2938 also talks to 300, 1200 and 2400 bps modems and fully supports MNP Levels 2-6.

The Telcor Model 2938 outperforms any other dial modem in the world. If

Look great without a lot of makeup.

Transforming a blank piece of paper into a document that's as appealing as this calls for plenty of page makeup.

But if you're like the rest of the world, you've barely got enough time to write, let alone struggle with formatting.

Well, now you don't have to. Because Ami is here. And it's about time.

Ami can save you about three quarters of the time you're currently spending on everything from simple letters and memos to presentations, reports and newsletters.

How?



By letting you write your words and make up your pages *at the same time*.

In fact, you don't have to do any makeup at all.

Because Ami gives you over two dozen pre-designed style sheets that let you instantaneously transform

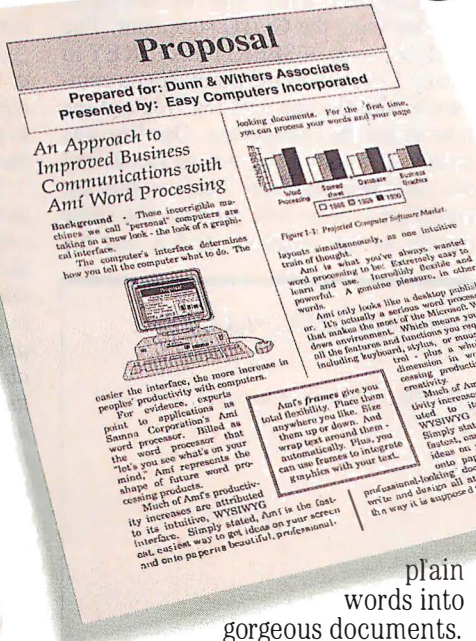

An Approach to Improved Business Communications with Ami Word Processing

Background - These incredible machines we call "personal" computers are taking on a new look - the look of a professional interface. The computer's interface determines how you tell the computer what to do. The

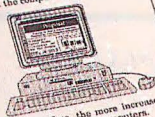

...easier the interface, the more increase in people's productivity with computers.

For evidence, experts point to applications as Sigma Corporation's Ami word processor. Billed as the word processor that "let's you see what's on your mind," Ami represents the shape of future word processing products.

Much of Ami's productivity increases are attributed to its initiative, WYSIWYG interface. Simply stated, Ami is the first and easiest way to get ideas on your screen and onto paper as beautiful, professional-

looking documents. For the first time, you can process your words and your page



Figure 1: Projected Computer Software Market

layouts simultaneously, as one intuitive train of thought.

Ami is what you've always wanted word processing to be. Extremely easy to learn and use. Intuitively flexible and powerful. A genuine pleasure in editing words.

Ami really looks like a desktop publisher. It's actually a serious word processor that makes the most of the Microsoft Windows environment. Which means you get all the features and functions you require - plus a whole new dimension in word processing productivity and creativity.

Much of Ami's productivity increases are attributed to its initiative, WYSIWYG interface. Simply stated, Ami is the first and easiest way to get ideas on your screen and onto paper as beautiful, professional-looking documents. Think - write and design all at once - naturally. It's a way it is supposed to be.

worry. A runtime version is included.)

You can integrate text and graphics. Import both from other programs. And admire your documents from four fully editable page views.

Right now, we suggest you admire the \$199 price tag and

"A fast personal word processor... that makes it easier to produce great-looking reports, letters and memos than any other PC word processor."

PC/Computing

"Surprisingly sophisticated... quite simple to learn and use... among the most powerful of the executive word processors."

Michael J. Miller, in InfoWorld

"Makes desktop publishing class output a snap for the average user."

William Zachmann, in PC Week

plain words into gorgeous documents.

Ami looks a lot like a desktop publisher. And the documents you can create with it have desktop publishing written all over them.

But as you'll quickly discover, Ami is a serious word processor that makes the most of Microsoft® Windows.

(If you don't have Windows, don't

send in this coupon right away.

Or just pick up the phone and call us at 1-800-831-9679.

Then you can take advantage of our 30-day money back guarantee.

Now that should help you make up your mind.

SAMNA

Make me look great for \$199.

Please rush me Ami.

Name _____

Address _____

City/State/Zip _____

Disk size: 5¼" 1.2MB 3½" 720K

Phone _____

Check enclosed AMEX Visa MasterCard

Card No. _____ Exp. _____

Send coupon to: SAMNA, 5600 Glenridge Drive, Atlanta, GA 30342

Add \$10 for shipping & handling (GA residents add sales tax). Prices valid in U.S. only.

CALL 1-800-831-9679 FOR YOUR NEAREST DEALER.

BYTE

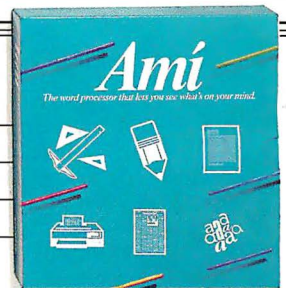

Requires IBM® AT, PS/2 or compatible (80286 or 386 CPU); EGA, VGA, or Hercules compatible displays; MS/DOS 3.0 or higher.

Ami is a trademark of Samna Corporation. All other trademarks and copyrights are acknowledged.

Circle 241 on Reader Service Card

rience implementing B-trees. My interest arises, in part, from the differences in our approaches to implementing B-trees. Some of my routines, such as insertion routing, are recursive in nature, whereas Grehan's approach is interactive.

I found the series enjoyable and informative. However, I was somewhat dismayed with listing 4 (January, page 390), the pseudocode for SEEK_NEXT_KEY. In particular, I believe that the unstructured use of the GOTO statement is inappropriate. Furthermore, this listing provides an excellent example of the need to use structured code whenever possible.

First, I must assume that there was a typographical error in the listing and that GOTO L1; should have read GOTO L2; since the only label called L1 is in listing 3 on page 388. Proceeding with this assumption, I found that label L2 was nested within a WHILE loop that is also nested within a REPEAT loop. A GOTO statement should never transfer control to

the middle of a control structure, such as a WHILE loop or a REPEAT loop. The question arises, as in this case, as to what happens after the GOTO statement is executed. Since the WHILE statement was not executed, where should control be transferred when the END statement for the WHILE is encountered? Should control be transferred to the WHILE statement or continue on to the next (END) statement? The problem arises again when the END statement for the REPEAT statement is encountered.

If you accept the premise that I have presented, the next question is whether SEEK_NEXT_KEY can be rewritten without using the GOTO statement. The modified code of SEEK_NEXT_KEY in listing 1 illustrates the point. If you compare it with Grehan's listing, you can see how minor the changes are. One line was modified, another line was replaced, and the label was removed. I believe that the modified routine will produce the same results as the original, and it has the

added advantage of being more readable.

I hope that Grehan will find my comments useful. On the other hand, if I have misinterpreted his pseudocode, I would appreciate further clarification.

Gary W. Wester
Normal, IL

First of all, thanks for catching the typo; label L2 should have been L1. My intention for the WHILE loop is that the body of the loop continues to execute as long as the enclosing condition is satisfied. Even though the WHILE statement precedes the loop body, control doesn't pass out of the loop at its completion until the condition is reevaluated and found to be false.

Next, the code you presented does show a GOTO-less SEEK_NEXT_KEY algorithm, and I thank you for taking the time to present it. But let me point something out.

The pseudocode that I presented in that particular column was derived from the original machine code. I sought to make the pseudocode as structured as possible while following what was really going on in the assembly code. (In fact, I was amazed at the amount of structure I was able to impart.) Consequently, while the listing you've shown would work, it does not accurately reflect what takes place in the actual program, and I wanted the pseudocode to track the program for the benefit of those readers who would either upload or purchase the source code.

I'll do my best to keep GOTOs out of the pseudocode listings. But if I am forced to include any, I'll be sure to add enough comments to the code so that there will be no confusion over program flow into or out of looping structures. —Rick Grehan

Price Curve

I have a few comments regarding "Migrating: Up or Down?" by Wayne Rash Jr. in the Fall 1988 *IBM Special Edition*.

It seems to me that a distinction should be made between commercial applications and in-house applications that are not usually commercially available. As far as the latter are concerned, Rash is most likely to be right: All that you need to make the mainframe/minicomputer-to-microcomputer move is a suitable compiler and lots of core memory and coffee. However, when it comes to the former class of applications, matters are not quite as simple as that. Most software houses making mainframe or minicomputer software are used to a much healthier profit margin than that of the microcomputer industry. This stems from the fact that buyers usually are at least small-

continued

Listing 1: Reader Wester's version of pseudocode for SEEK_NEXT_KEY.

```
SEEK_NEXT_KEY:
  IF number of keys in file = 0 then RETURN file empty error;
  IF file is rewound
    BEGIN
      CURRENT_KEY_SECTOR := Root;
      IFLAG := 0;
      KEYOFFSET := -1;
    END
  GET(CURRENT_KEY_SECTOR);
  REPEAT
    IF IFLAG NOT = 0
      BEGIN
        IF KEYOFFSET NOT = number of keys on node
          BEGIN
            IFLAG = 0;
            RETURN;
          END
        IF Pseudo stack is empty
          BEGIN
            REWINDKEY;
            RETURN end of file error;
          END
        POP(CURRENT_KEY_SECTOR, KEYOFFSET);
        GET(CURRENT_KEY_SECTOR);
      END
    ELSE
      BEGIN
        KEYOFFSET := KEYOFFSET + 1;
        IFLAG := 1;
        WHILE key node pointer at KEYOFFSET NOT = 0
          BEGIN
            TEMP := key node pointer at KEYOFFSET;
            PUSH(CURRENT_KEY_SECTOR, KEYOFFSET);
            CURRENT_KEY_SECTOR := TEMP;
            KEYOFFSET := 0;
            GET(CURRENT_KEY_SECTOR);
          END
        END
      END
    END REPEAT
```

Turn a task into child's play.

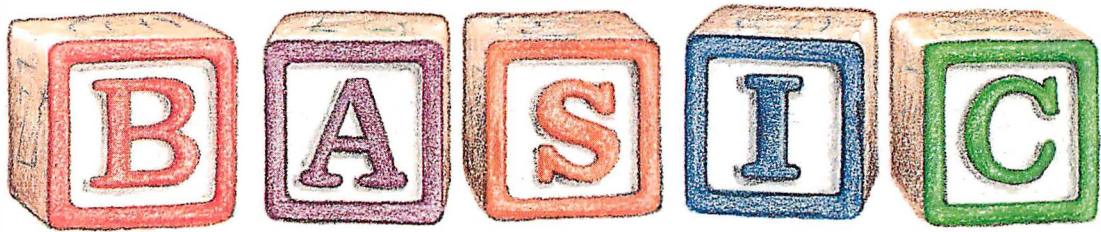

PROBAS™ Basic Programming Library

Announcing **PROBAS** Version 3.0, now with over 365 assembly routines to really kick QuickBASIC and BASCOM into high gear. **BYTE** magazine calls **PROBAS** a "Super-charger for QuickBASIC". Thousands of programmers rely on **PROBAS** to make their life easier and to enhance their programs with features like:

- A 1,000 page 2 volume manual
- Full-featured windowing
- Screen snapshots (Text & Graphics)
- String, array, and pointer sorts
- Lightning-fast file I/O
- Full mouse support

Create dazzling screens in text mode, CGA, EGA, VGA or Hercules graphic modes. Save and restore screen snapshots to arrays, EMS memory or files. Full featured windowing to meet the most demanding jobs. The **PROBAS** system of virtual screens allows you to draw full or partial screens to memory, and then snap them on in an eyeblink. You can even create virtual screens far larger than the display screen.

Sick of running out of string space? Store hundreds of K in numeric arrays or megabytes in extended or expanded memory. Tired of using a kludgy SHELL to DIR to read a directory or archive files? Scan sub-directories or .ARC files using wild-cards and store thousands of file names, dates, and times. Wish you could drag a window containing text or a menu around the screen with a mouse? It's easy!

PROBAS gives you a complete set of blazingly-fast file routines. Read or write huge chunks of data at a clip, with file locking and error handling so that you can even use them in subprograms. You'll never want to use BASIC's file I/O again! Sort data with lightning fast array and pointer sorts. Search files or arrays at assembly speeds. **PROBAS** also has over 200 other essential services including handy string, date, time, directory and array manipulation, string, screen and data compression, full mouse support, valuable equipment and input routines and faster replacements for most BASIC commands.

Whether you are a professional or a novice, **PROBAS** will boost your BASIC in ways you never dreamt possible. **PROBAS** allows professionals to save time and work and lets novices write professional-quality programs quickly and easily. After all, how much is a few hundred hours of your time really worth?

For all versions of QuickBASIC and BASCOM including BASCOM 6.0 for OS/2. **Just \$135.00!**

PROREF™ On-Line Help For PROBAS

PROREF provides pop-up help for the routines in **PROBAS** and is an extension of the QuickBASIC programming environment. Find help on any routine with a few keystrokes or mouse clicks. Pop-up an ASCII chart, calculator, scan code module, box diagram, your own help information or almost any DOS program via a hot-key. **Just \$50.00!**

PROSCREEN™ Screen Management

PROSCREEN is a full-featured screen generator/editor that will save you more design and coding time than you ever thought possible. **PROSCREEN** treats screens like a word processor treats text to provide complete control over characters, colors, and placement. Design input screens with up to 130 fields and 19 pre-defined and 2 user-defined masks. Use **PROBAS** or the included BASIC/Assembler subroutines to access the screens. No kludgy code generators here! Comes with subroutine source, extensive on-line help, and a 285 page manual. **Just \$99.00!**

PROMATH™ Mathematics Library

PROMATH is a collection of over 150 high-level routines that provide mathematical functions and operations for programmers who often work in mathematics, science, or engineering. Complex variables, real and complex matrices, real and complex trigonometric and hyperbolic functions and their inverses, solution of linear equations, integration, differential equations, Fast Fourier transforms, graphics support, and many other useful routines are provided.

For years Fortran has been the language of choice for scientific and engineering applications, but it lacks many of the useful features of QuickBASIC. **PROMATH** contains most of the Fortran mathematical and numeric functions and allows you to easily translate Fortran code to BASIC or write new programs in BASIC while retaining Fortran's numerical prowess.

The **PROMATH** manual is over 200 pages and provides a complete description of each routine, including any algorithm and the mathematical formula the routine uses, shown in standard notation. For QuickBASIC 4 and BASCOM 6 only. **Just \$99.00!**

PROBAS™ TOOLKIT

The **TOOLKIT** is a collection of assembly and BASIC modules that use the **PROBAS** library to save you even more hours of grunt work. Why spend hundreds of hours re-inventing the wheel when you can just plug in **TOOLKIT** modules like:

- Menu Generators
- Fast B-tree indexing
- Mini-editor with word-wrap
- Patch .EXE files
- Protected storage areas
- Julian date routines

The **TOOLKIT** also includes clock, calendar, windowing, BCD math routines and much more, complete with BASIC source code and a comprehensive manual. The **PROBAS TOOLKIT** adds capabilities and helps conserve your most valuable asset of all—time! Requires **PROBAS**. **Just \$99.00!**

PROBAS™ TELECOMM TOOLKIT

The **PROBAS TELECOMM TOOLKIT** is a collection of high-level communications modules that you plug into your code to provide popular file transfer protocols, terminal emulations, login scripts and baud rates up to 115,200 baud. You get:

- Xmodem/Modem7/Xmodem-1k
- Ymodem (single and batch)
- CRC-16 and Checksum
- VT52, VT100, ANSI BBS etc.
- Auto Dialer & data base
- Documented BASIC source

Why use clumsy SHELLs to complex terminal programs when you can plug just the communications routines you need into your code? Implement just the features and commands you want. Requires **PROBAS**. **Just \$75.00!**

Our thirty day, money-back guarantee assures you the highest quality and our technical support staff is always ready to help.

HAMMERLY
COMPUTER SERVICES, INC.

9309 JASMINE COURT • LAUREL, MD 20707

(800) 343-7484

INT'L. ORDERS: (301) 953-2191 FAX: (301) 725-8147
BBS: (301) 953-7738

Add \$5.00 per item (\$8.00 Canada) for shipping per order. Europe: \$39.00 for 1st item plus \$5.00 for each additional item. Visa, M/C, C.O.D. (US Only) checks and approved POs accepted. Trademarks **PROBAS**, **PROREF**, **PROSCREEN**, **PROMATH**: Hammerly Computer Services, Inc. QuickBASIC, BASCOM: Microsoft Corp.

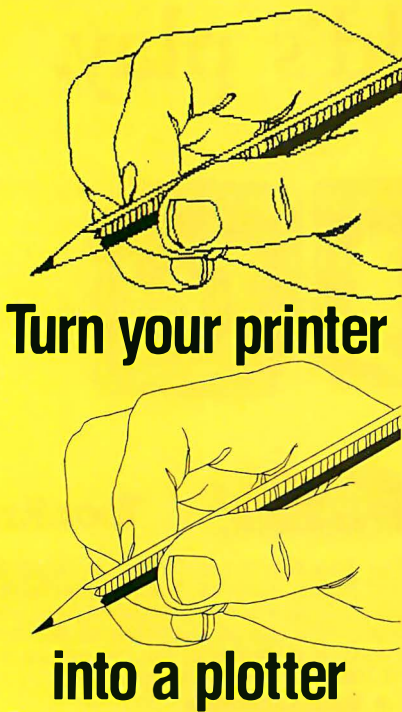

Turn your printer into a plotter

Imagine your present printer turning out crisp, high resolution plots while you continue to work, *without interruption*, at your PC.

The EOgraph Plus add-on board lets you do that, and more.

You have total control over eight different line widths, and as many colors as your printer offers.

You can produce drawings 15 feet long, and longer, in any carriage width.

How about multiple plots, or automatic queuing of text and plots? Yes, the EOgraph Plus lets you do that, too—with ease.

Think of it! Using virtually *any* CAD or graphics program, you can work at your PC while your printer generates plotter-quality drawings with nearly incredible detail.

Best of all, you get all of this without the headaches, or expense, of baby sitting a plotter.

Thousands of users agree: No other PC add-on can increase your productivity, or pay for itself so quickly, as the EOgraph Plus.

It may sound too good to be true, until you call for the facts, toll-free, at 1-800-548-5780.

DEALER INQUIRIES
WELCOME

**EOgraph
Plus™**

Eotron Corp / 121 Westpark Road / Dayton, OH 45459

Please send information and independent test reports to:

NAME _____
ADDRESS _____
CITY _____ STATE _____ ZIP _____

BYT

size corporations that can afford to pay \$5000 and up for an application. You would never get away with prices like that in the microcomputer world. Thus, there is not much incentive to port.

I think we'll have to wait for the time when corporations make the shift from the centralized-mainframe way of doing things to the decentralized network-of-high-powered-PC-with-server way of doing things. Alas, that may be quite a while—by the year 2001, perhaps?

T. Christiansen
Copenhagen, Denmark

I have to agree that with prices that normally run less than \$1000 (U.S.), there is a smaller margin of profit per package than there is with mainframe and mini-computer software. You must know, of course, that the net profit per package hardly reflects the true profit picture for a software company. Otherwise, Lotus, Ashton-Tate, and Microsoft would be paupers. The reason that they are not is simply that there are many millions more microcomputers than there are minicomputers or mainframes. As a result, these companies make their money in volume. In any case, you are correct.

I was aiming my comments more at organizations that would be moving their own applications rather than those in commercial sales. I think, however, that the same rules apply to any package, whether it is developed in-house or commercial. In addition, the economics work out well for the smaller computer. If you had to sell the same package to a minicomputer user or a microcomputer user, you would probably sell it for about \$5000 (U.S.) for the minicomputer package and \$750 (U.S.) for the microcomputer package. The difference is in the number of users. Most minicomputers will support between 64 and 128 users. Microcomputers, on the other hand, support one user. Multiply 750 by 64, and you will begin to see why microcomputer software vendors are so profitable.

—Wayne Rash Jr.

Word Processor Woes

Somebody finally said it. Ezra Shapiro's comments on overloaded word processors ("The Blight of Bloated Software," January) are my sentiments exactly. I would add that the bells and whistles craze started before laser printers.

When I put together my IBM clone, I could hardly wait to try out WordStar or some other supercharged word processor. I was disappointed. All I wanted was a fast word processor for letters, memos, and reports. I was leaving a Commodore

64 that, with its word processing cartridge, was up and running before the monitor was warm. Six seconds, and I was producing.

I tried others that were no better. The Commodore went back on-line. A friend recommended PFS. I loaded it and printed out a memo over my lunch hour without help from the manual. All I want now is a spelling checker with the same simple word processor.

Robert Ziller
New Richmond, WI

Awards Candidate

Thanks for "The BYTE Awards" (January). One truly unique hardware/software item that you did not list is Dave Small's Spectre 128 Macintosh emulator (for the Atari ST). To the best of my knowledge, it's the only emulator that allows HyperCard, Excel, Microsoft Word, Microsoft Works, MultiFinder, and so on, to run on a non-Mac computer. This hardware/software emulator uses the 128K-byte Apple ROM chips and runs the programs as fast as or faster than a Mac SE or a Mac Plus.

Spectre 128 emulates a Mac Plus; Small's earlier emulator (Magic Sac) uses the 64K-byte ROM Apple chip set and emulates a fat Mac on the 1040ST. A Translator box is also available that allows Mac disks to read/write on an ST. The Epstart software program lets me use my Epson MX-80 printer as an "Imagewriter" to print out materials.

This emulator has opened up Mac software to thousands of Atari ST users. It's truly an award winner.

Conrad Weiler
Santa Barbara, CA

Author's Lament

I'd like to thank Don Crabb for the very nice write-up of my program, Music Mouse, in "MS-DOS, MiniFans, Math, and Mice" (October 1988). I think there is one point very much worth making, though, in the wake of his description.

Programs like mine are often the work of single individuals, not companies, as Crabb implies by attributing both the program's design and the terminology, concepts, and features it introduces to its publisher (Opcode Systems). To attribute a program's content elsewhere than to its actual designer/author does a substantial disservice to the many independent software authors who have pioneered new uses of computers and helped make these new tools meaningful to people in original ways that would never have happened if design and development

continued

It's time to get a new, better linker. . .

.RTLink™

\$195.00

"The more I used .RTLink, the more I *USED* it...."

a sure sign that a product actually fits one of my programming needs. It significantly improved my productivity...."

Steve Steiner, Data Based Advisor February, 1989

UNIQUE FEATURES:

- **Advanced Overlays** - supports advanced overlay management in ALL languages, even Turbo C, and, for the first time, QuickBASIC. Features multiple overlay areas, nested overlay areas, internal and external overlays, and reloading of overlays on function return. (see 'Other Features:' below)
- **Run Time Libraries (.RTLs)** - .RTLs are optional, easily-created files that can be used to manipulate link speeds, and significantly REDUCE .EXE SIZE. Generally, .RTLs are files that contain common code which is repeated in groups of .EXE files. These files can dynamically link to .EXEs at load time. They reduce the repetitive storage of common code. This results in smaller .EXEs and reduces disk space requirements on shipping media, target and development machines, and reduces the amount of time required to modem updates to remote locations. Production-version RTLs usually contain commonly used language-library code and/or utility code. However...
- **Faster Linking** - ...during development, RTLs can be used to store pre-linked modules. This allows programmers to set aside much of the code that is not being modified, thereby significantly enhancing link speeds. In straight links, RTLink is faster than your current overlay linker. However, RTLink is even faster when RTLs are used as a productivity tool during the development and testing phase. All of the code within an .RTL is pre-linked. Therefore, you can place stable code into an .RTL to eliminate the need to relink it during development. This use of .RTLs can result in lightning fast linking without affecting program testing.
- **Profiling** - provides highly-detailed performance statistics about your program without code modification. Timing sequences are adjustable to thousandths of a second. Source code is provided for the read/analysis utility which allows customized statistics reporting.
- **LIBLIST** - cross-references .OBJ and .LIB files. Illustrates interrelationships and dependencies between modules. Provides much more detailed information than utilities such as LIB.

"The only significant advancement in linking technology in years"

RTLink is a feature-rich overlay linker with unique capabilities and functions which are not available in any other linker, or even attainable at the same high degree of performance in another product.

You can **quickly begin using RTLink** just as you would your current linker, because RTLink supports common link-input formats. However, unlike other linkers, .RTLink provides other easy-to-learn features which can dramatically increase your productivity and your programs performance

"I am very impressed with the product and the people at Pocket Soft, Inc. The product does what it claims to do and the people know their stuff."

Don Powells,
Nantucket Corporation

OTHER FEATURES:

- Multiple Overlays (32,767)
- Nested Overlays (32,767 deep)
- External Overlays
- Internal Overlays
- Maps files
- On-line help
- Quick-start files (ARFs on disk)
- Excellent documentation
- Free tech support
- Easy to use
- Easy to learn
- No performance degradation
- No source code changes
- No royalties
- No risk (30 day refund policy)

WORKS WITH:*

- Microsoft® C™
- Turbo C®
- Clipper™
- MASM™
- QuickBASIC™
- BASIC
- COBOL
- FORTRAN
- Clarion™
- Quicksilver™

*And most other DOS Compilers which produce .OBJ files.

Order yours today! \$195.00

Visa, Master Card or C.O.D

Call: (713) 460-5600

FAX: (713) 460-2651

Pocket Soft, Inc. 7676 Hillmont, #195 Houston, TX 77040

Trademarks: All Pocket Soft products are trademarks of Pocket Soft, Inc. Other brand and product names are trademarks of their respective holders. © 1989 Pocket Soft Inc.

Circle 209 on Reader Service Card

MAY 1989 • BYTE 35

The
ProSpeed™ 386
desktop.

To understand
its massive
power,

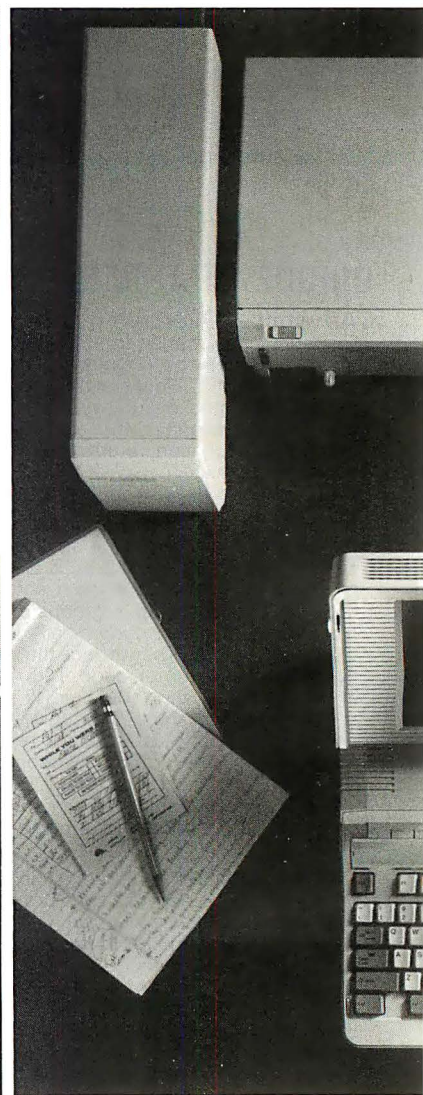
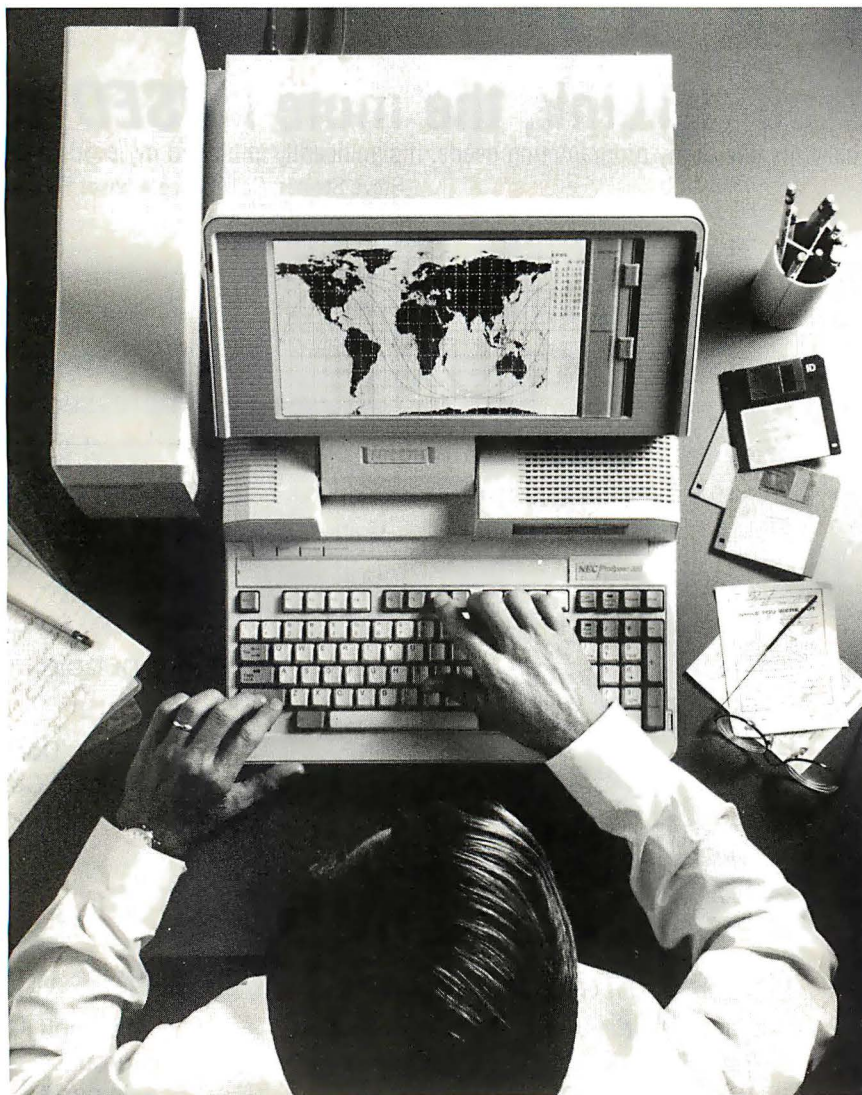

In the past, people who were serious about their computers have had a serious dilemma.

They could either buy a powerful desktop and give up any thoughts of portability. Or get a laptop, and forget about expansion and connectivity capabilities.

But never could they find a computer flexible enough to give them both.

Until now. With the ProSpeed 386 from NEC.

As you'd expect from a powerful 386 desktop, it runs at a swift 16MHz, has a full seven expansion slots and up to four drives. So it can handle anything you throw its way.

And when you want to take it on the road, it's still a high-powered computer. The laptop unit is not only available in both 40 and 100 MB hard disks, it's also battery operated and has up to 10 MB's of memory. There's even a paperwhite monograph screen with EGA

you have
to take it
apart.

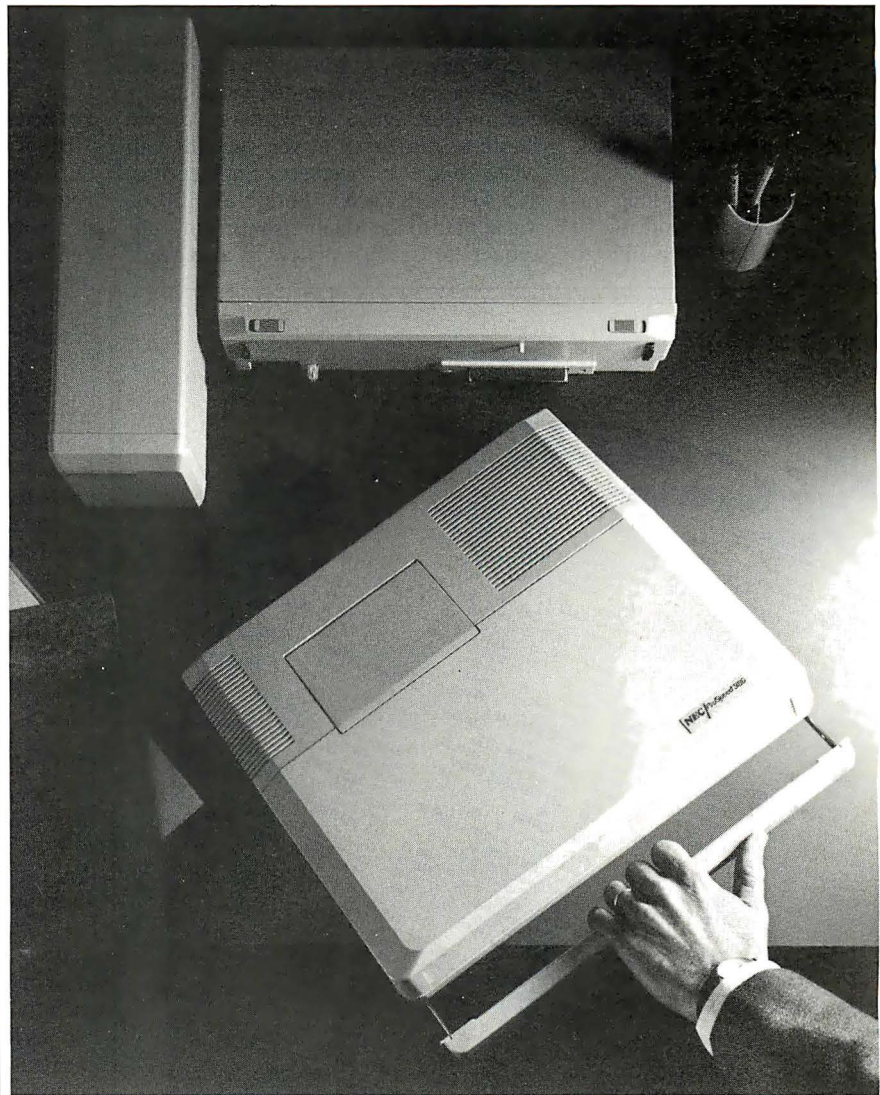
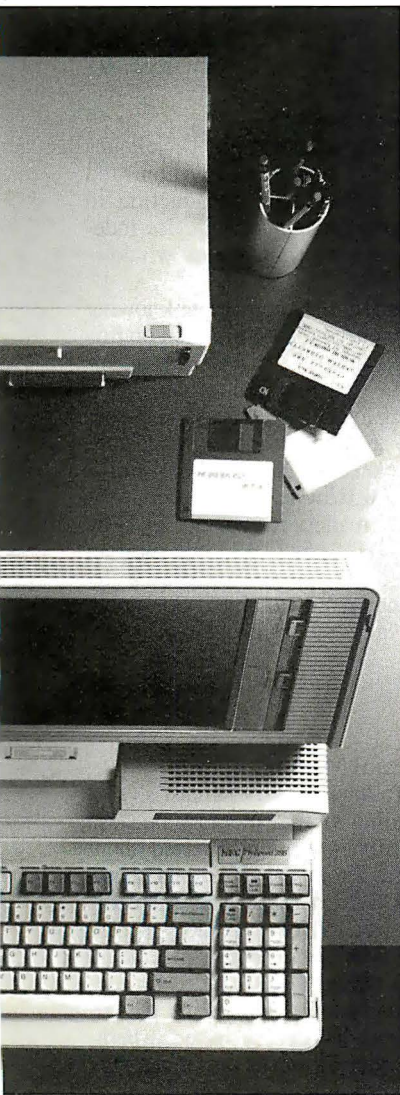

resolution that provides the readability and graphics capabilities of a full-sized CRT.

All this and total connectivity capability, too. When you want to turn it back into a desktop, you merely slide the computer into a unique docking station that never

leaves your desk. It contains two standard drive bays as well as the capacity for four full-sized cards. So in a matter of seconds, you're fully integrated back into your office.

No manual reconfiguring. No phone lines to connect. No cable hook ups.

The price isn't a hassle either. So if you'd like us to continue taking the ProSpeed 386 apart, call NEC Home Electronics (USA) Inc. at 1-800-FONE-NEC. Or, if you'd like to dissect it yourself, call for product literature at 1-800-826-2255.

were left entirely to corporations and marketing departments.

In cases such as Music Mouse's, publishers are responsible for distribution and other services to a program's end users, but not for a program's design or development. This division of labor is especially common in software for music and art.

The U.S. is a country with a long tradition of solitary inventors working at their own expense on their own time to

realize personal visions, and some of us in this field still fall into that tradition.

Also worth mentioning is the fact that, in addition to the Macintosh version Crabb described, Music Mouse is now also available in expanded versions for Amiga and Atari ST computers. Anyone interested in these newer versions can write to me at Aesthetic Engineering, 175 Duane St., New York, NY 10013. An update to the Macintosh version, subsequent to Crabb's review, is also avail-

able for its publisher, Opcode Systems, and it does run properly under Multi-Finder.

Laurie Spiegel
New York, NY

Information Source

"The X Window System" by Dick Pountain (January) was a well-written and generally informative introduction to this emerging standard for device-independent, network-transparent windowing systems.

Your readers may appreciate knowing of another source for information on this technology: the X User's Group, an independent, international organization started in January 1988. XUG sponsors Xhibition, an annual trade show and conference devoted to X Windows, and it publishes *XNextEvent*, a newsletter.

Interested readers can contact XUG by telephone at (617) 547-0634, via Internet E-mail at xug@expo.lcs.mit.edu, or by mail c/o Integrated Computer Solutions, 163 Harvard St., Cambridge, MA 02139.

David Lewis
Cambridge, MA

OS/2 Virtual Memory

I've been following Mark Minasi's OS/2 saga regarding virtual memory because so little has been written or tested about this feature. From the time data that's given in "OS/2 Consumerism" (December 1988), the virtual memory sector write/read swap times can be calculated to be in the range of 3 seconds to 4.3 seconds (on his system). This is not trivial, and, as Minasi has demonstrated, whether virtual memory works or not depends on how the program is crafted.

Consider this. Spreadsheets generally save data in row/column order. So what happens when you recalculate in column mode? Thrash! And what of these humongous programs with subroutines scattered hither and yon when they enter a nested loop? Thrash!

Not that long ago, CP/M programmers had to arrange program modules so that the overlays allowed the program to function in perceived real time. Virtual memory will apparently require the same attention to detail.

For BYTE, the time has now arrived to develop a virtual memory/time test curve in which a program is progressively squeezed into less RAM and its performance time measured. This would establish the Perceived Time Threshold, the point at which the slowing of the program begins to irritate the user, and the

continued

SUNDAY 10-5 **PROMPT DELIVERY**

GRAPHIC CARD
ATI VGA Wonder 289.99
Paradise VGA Plus 254.99
Para. VGA Plus-16 449.99
Paradise VGA Prof. 339.99
Video 7 Fast VGA 459.99
Vid. TV Ram VGA

MONITORS
Amdeco 210 89.99
Mish Diam. Scan 479.95
NEC Multisync GS 239.00
CALL
NEC Multisync 2-A 549.99
CALL
NEC Multi Plus 249.99
NEC Multi XL 249.00
PGS Max 15 469.80
PGS Ultrasonic 569.00
Seiko Cal 1430 579.99
Zenith 14" Fla 39.99

PRINTERS
Diconix 150 cps 299.99
Diconix 300 cps 424.99
Diconix 300 Wide 299.99
Epson FX-850 299.99
Epson FX-1050 514.99
Epson LQ-500 714.99
Epson LQ-850 899.99
Epson LQ-1050 899.99
Epson LQ-2550 1299.00
Epson LX-800 189.00

COMPUTERS
Mac SE/30 40 MB 1229.00
Mac Plus 3999.00
Mac II X 800K Dr. 2125.00
Mac SE 2-80MB 2549.99
Mac SE 2-16 MB RAM 4999.99
Mac II 4 MB RAM 429.00
Mac II 8 MB RAM 729.00
Mac II X 80 MB 1029.00
Mac Color Mon. 499.00
Image II 1299.00
20MB Ext. Dr. 189.00
Apple Scanner 1969.99
2400 Ext. (MAC) 1969.99
AST PREM 286 140 X 1 MB Ram 40 MB 1549.99
AST PREM 286 512K 1.2 FID 40 MB HD 1549.99
AST PREM386 C/20MHz 1 MB 1.2 FID 1969.99

MOUSE
Logitech w/Solow. 99.99
Logitech C-7 69.99
Logitech Clear Case 79.99
Logitech H1 REZ 99.99
Microsoft Mouse 3450.00

LASER PRINTER
Apple Laser II NT 1399.99
Canon Series II 655.99
Canon Series II 1584.95
HP Laser Jet II 329.99
HP Laser Jet HP 2729.99
HP Laser II D 3029.99

MODEMS
Everett 2400 Int. 135.00
Enter 2400 Ext. 169.00
U.S. ROBOTICS Courier HS1-2400 270.00
Courier HS1-9600 575.00

FACSIMILE (FAX)
Canon Fax B 1199.99
Murata 1900 699.99
Murata 1600 919.99
Pan. KXF-120 924.99
Pan. KXF-150 1299.99
Pan. UF-250 1509.99
Ricoh FR-800 619.99
Sharp FO-220 774.99
Sharp FO-300 1169.99
Sharp FO-400 1169.99
Sharp UL-350 1169.99

COMPAQ
NEC P-5200 499.99
NEC 5300 649.99
Okidata 320 329.99
Okidata 321 454.99
Okidata 390 599.99
Okidata 393 174.99
Panasonic KXP-1180 499.99
Panasonic KXP-1524 399.99
Panasonic KXP-1592 169.99
Panasonic KXP-1595 299.99
Star Nc-1000 359.99
Star Nc-2400 549.99
Tosh. Exp. Writer 301 849.99
Tosh. P-341 SL 544.99
Tosh. P-351 SX 849.99

CANON COPIERS
PC-57 325.00
PC-58 325.00
PC-59 325.00
PC-60 325.00
PC-61 325.00
PC-62 325.00
PC-63 325.00
PC-64 325.00
PC-65 325.00
PC-66 325.00
PC-67 325.00
PC-68 325.00
PC-69 325.00
PC-70 325.00
PC-71 325.00
PC-72 325.00
PC-73 325.00
PC-74 325.00
PC-75 325.00
PC-76 325.00
PC-77 325.00
PC-78 325.00
PC-79 325.00
PC-80 325.00
PC-81 325.00
PC-82 325.00
PC-83 325.00
PC-84 325.00
PC-85 325.00
PC-86 325.00
PC-87 325.00
PC-88 325.00
PC-89 325.00
PC-90 325.00

SEAGATE DRIVES
PC-57 325.00
PC-58 325.00
PC-59 325.00
PC-60 325.00
PC-61 325.00
PC-62 325.00
PC-63 325.00
PC-64 325.00
PC-65 325.00
PC-66 325.00
PC-67 325.00
PC-68 325.00
PC-69 325.00
PC-70 325.00
PC-71 325.00
PC-72 325.00
PC-73 325.00
PC-74 325.00
PC-75 325.00
PC-76 325.00
PC-77 325.00
PC-78 325.00
PC-79 325.00
PC-80 325.00
PC-81 325.00
PC-82 325.00
PC-83 325.00
PC-84 325.00
PC-85 325.00
PC-86 325.00
PC-87 325.00
PC-88 325.00
PC-89 325.00
PC-90 325.00

ZENITH
184-12 FID 1949.99
184-2 20 MB 2349.99
286 1-FID 20 MB 4299.99
286 1-FID 40 MB 4299.99
386 1-FID 40 MB 199.00

HAND SCANNERS
Logitech Scanman 195.00
400 DPI NEW

EMERSON
JVC
Hayes
Star
Verbatim
DIABLO
COMMODORE
ORION
OKIDATA
QUADRAM
AMDEK

WORLDWIDE INQUIRIES PROMPTLY FILLED

GUARANTEED LOWEST PRICES
1-800-874-1235

TOLL FREE OUT OF N.Y.
IN N.Y.S. (800) 223-6779 — N.Y.C. (212) 463-8330
S & W COMPUTERS & ELECTRONICS
31 West 21 Street, New York, N.Y. 10011
HOURS: Sun. 10-5, Mon-Thurs. 9-6, Fri. 9-2, Sat. Closed • Credit cards charged at time of order. DISCOVER, M.C., VISA C.O.D. • Not responsible for type errors. Prices subject to change without notice. Returns with our written authorization. Qty. Ltd.

ALL MERCHANDISE SHIPPED IN FACTORY SEALED CARTONS, 100% GUARANTEED

Pop Quiz. Stop. This is a test. For the next 60 seconds, we will be conducting a quiz about Macintosh® II Videographics. Do not turn the page until you have looked at the visual clue and answered all the questions.

Which Macintosh II graphics card offers the widest range of capture and display resolutions—NTSC, PAL, Apple® Monitor, hi-res, interlaced, non-interlaced and other modes?

a) NuVista 2M b) NuVista 4M c) All of the above

Name the only videographics card which provides true-color, real-time capture and broadcast-quality display while occupying only a single slot in a Macintosh II.

a) NuVista 2M b) NuVista 4M c) All of the above

Which videographics card offers full QuickDraw™ compatibility at 1,2,4,8,16 or 32-bits per pixel?

a) NuVista 2M b) NuVista 4M c) All of the above

Visual clue for Videographics test.

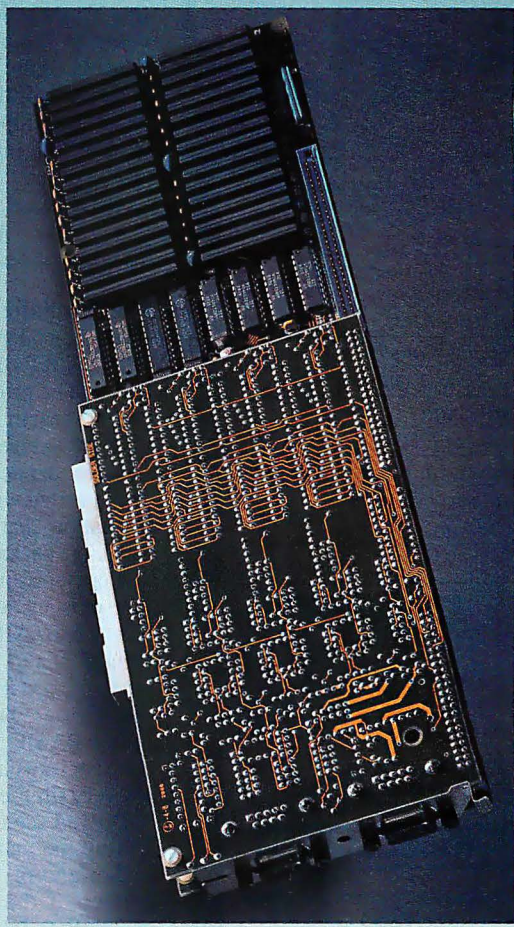

If you chose (c) on all three questions, congratulations! You know that the NuVista series from Truevision is the answer to all your advanced videographics needs. The NuVista is available with either 2Megabytes or 4Megabytes of video memory, and creates professional video effects and computer graphics using any QuickDraw compatible software, now and in the future. No patches, no gimmicks, no hassles.

So whether your application is video production, digital pre-press, presentation graphics or 3D renderings, you'll find the NuVista will pass *your* test with flying colors. Oh, and if you answered (a) or (b) to any question above, give yourself half credit. Then obtain even more NuVista information by requesting a copy of our educational brochure True color? True answers. or visiting your local Authorized Truevision Reseller. Either way, you can find all the answers with a NuVista. Call us at **800-858-TRUE**.

You may now return to your regular reading.



7351 Shadeland Station, Suite 100, Indianapolis, IN 46256

INTERNATIONAL: Canada 416/499-9400 France 33-13-952-6253 Italy 39-2-242-4551 Switzerland 41-1-825-0949 U.K. 44-1-991-0121
West Germany 49-89-612-0010 Other 617-229-6900

Apple and Macintosh are registered trademarks and Quick Draw is a trademark of Apple Computer. Truevision is a registered trademark and NuVista is a trademark of Truevision, Inc.
© Truevision Inc. 1989

Circle 273 on Reader Service Card

Rack & Desk PC/AT Chassis

Integrand's new Chassis/System is not another IBM mechanical and electrical clone. An entirely fresh packaging design approach has been taken using modular construction. At present, over 40 optional stock modules allow you to customize our standard chassis to nearly any requirement. Integrand offers high quality, advanced design hardware along with applications and technical support all at prices competitive with imports. Why settle for less?

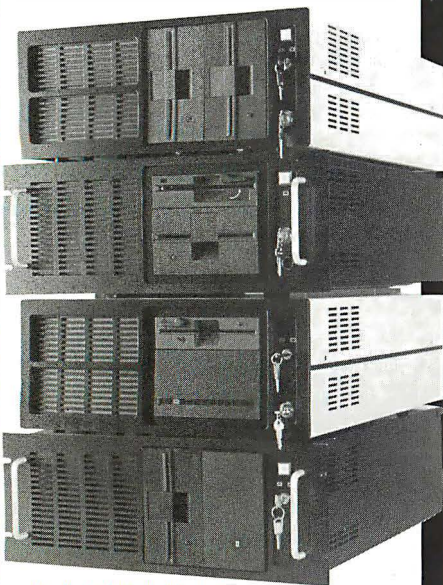

Rack & Desk Models

Accepts PC, XT, AT Motherboards
and Passive Backplanes

Doesn't Look Like IBM

Rugged, Modular Construction

Excellent Air Flow & Cooling

Optional Card Cage Fan

Designed to meet FCC

204 Watt Supply, UL Recognized

145W & 85W also available

Reasonably Priced

Now Available
Passive
Backplanes

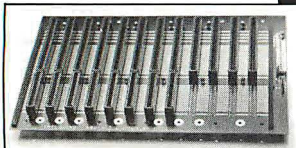

INTEGRAND

RESEARCH CORP.

Call or write for descriptive brochure and prices:
8620 Roosevelt Ave. • Visalia, CA 93291

209/651-1203

TELEX 5106012830 (INTEGRAND UD)

FAX 209/651-1353

We accept Bank Americard/VISA and MasterCard

IBM, PC, XT, AT trademarks of International Business Machines.
Drives and computer boards not included.

ASK BYTE

Thrash Point, which marks the spot where the program goes logarithmically into oblivion.

The user would benefit from knowing the real memory requirements of an OS/2 program. After all, it would make a difference whether the program is to operate in the foreground or background, or if the program has switches to allow for speed/memory trade-offs.

Walter J. Rottenkolber
Visalia, CA

FIXES

- "Dialing Up 1990" by Brock N. Meeks (January) states that XMODEM transfers files in 128K-byte packets. In fact, XMODEM transfers files in 128-byte packets.
- Michael E. Nadeau's March text box entitled "Battle of the SXs" (page 278) contained two inaccuracies concerning the Twinhead Superset 490. The unit contains three 16-bit and one 8-bit expansion slots, not four 16-bit slots, as stated. Also, the Magic Combo graphics driver is a chip on the motherboard, not a card. BYTE regrets the errors.

ASK BYTE

Breaking the Barrier

I am considering moving up from an IBM PC XT compatible to an 80386 machine. The problem is that there's an apparent dearth of language software to take advantage of the 80386's capabilities. In particular, I need a language package that will avoid the 64K-byte segmentation that is built into 8086/8088 language packages.

I currently use Turbo Basic, and I'd like to stick with it or some other advanced BASIC. I reluctantly would change over to FORTRAN or some other language just to get around the segmentation barrier, but I have written and use many BASIC programs routinely. A massive translation job would be feasible but very time-consuming.

Do you see on the horizon any big effort by the major software houses, such as Borland or Microsoft, to market upgrades of their 8086/8088 language packages to take advantage of 80386 capabilities? I have written Borland regarding the prospect of its coming out with a new version of Turbo Basic. Borland said that, as a matter of policy, it doesn't reveal its plans of this nature. I understand

the company's position in a highly competitive market, but there is a gaping hole in software availability in this regard. Meanwhile, I, and presumably others, hang in suspense.

T. H. Siddall III
New Orleans, LA

There are at least two routes you can take. One is to purchase an 80386 machine and get a copy of MetaWare's High C 386 (MetaWare, Inc., 903 Pacific Ave., Suite 201, Santa Cruz, CA 95060, (408) 429-6382). Coupled with Phar Lap's 386|ASM|LINK assembler/linker package, you can generate true 80386 protected-mode applications.

Another possibility that allows you to keep your XT clone is to purchase an 80386 coprocessor. In particular, A.I. Architects' HummingBoard (A.I. Architects, One Intercontinental Way, Peabody, MA 01960, (508) 535-7510) plugs into an XT or an AT, and running OS/386 gives you a DOS-like environment with many of the advantages of the protected-mode world. This would at least let you run your existing BASIC applications while porting to the 80386 world. OS/386 includes software for patching Microsoft C 4.0 and Microsoft FORTRAN to allow these languages to create protected-mode programs.—R. G.

The Need to Test

I want to build a digital chip tester, and my idea is to let the computer read and set the pins. I would use one line from the computer as a strobe, and the others could set and read latches that would hold input data.

My problem is that I need a parallel port that I can read from as well as write to. I remember an article in BYTE describing how to modify a parallel port to make it bidirectional. Software is no problem for me; I just need some help with the hardware.

Randall Kern
Camano Island, WA

Before you rush off to build your digital chip tester, you might want to investigate Steve Ciarcia's IC Tester in the November and December 1987 BYTE. On the other hand, if you're determined to construct your own tester, refer to the September 1988 Circuit Cellar for the recipe for making a parallel printer port bidirectional.—R. G.

Solving Mathematical Problems

I have written a few programs in Quick-BASIC and C that manipulate mathemat-

continued

Virtual Memory for DOS!

MicroWay is your best source for the software and hardware you need to get true 32 bit performance from your 386. These include 32-bit tools, such as NDP Fortran and C, and the 32-bit applications that were developed with them (see last paragraph). These products run in protected mode under Unix, Xenix, or Phar Lap extended MS-DOS.

Starting with release 1.4VM, NDP Fortran and C not only access 4 gigabytes of memory, but run with Phar Lap's new VMM extension which provides 386 protected mode virtual memory. Now you can run a program with a 30 MB array on a 2 MB system simply by having 30 MB of free space on your hard disk.

MicroWay also offers transputer based parallel processing boards and languages that run in an XT, AT, or 386. Each of the T800 RISC processors on these boards packs the power

Dr. Robert Atwell, leading defense scientist, calculates that NDP Fortran-386 is saving him \$12,000 per month in rentals of VAX hardware and software while doubling his productivity!

Fred Ziegler of AspenTech in Cambridge, Mass. reports, "I ported 900,000 lines of Fortran source in two weeks without a single problem!" AspenTech's Chemical Modeling System is in use on mainframes worldwide and is probably the largest application to ever run on an Intel processor.

Dr. Jerry Ginsberg of Georgia Tech reports, "My problems run a factor of six faster using NDP Fortran-386 on an mW1167 equipped 386/20 than they do on my MicroVAX II."

of a 20 MHz 386/1167. Our best selling board, the Quadputer2™, has four T800s and boasts 40 MIPS/6 megaflops of processor throughput.

MicroWay manufactures Weitek 1167 and 3167 coprocessor cards that run with the 80386. Both cards include an 80387 socket. The 1167 is 2 to 4 times faster than the 80387. The 3167 runs 30% faster than the 1167 in double precision. The key to achieving this speed increase is our NDP Fortran or C and the new 32-bit applications that offer Weitek support. Either processor provides a dramatic increase in throughput for graphics intensive applications. These include VersaCad and Hoops 3D graphics, ANVIL 5000 CAD/CAM, SRAC and Swanson Analysis finite element packages, Mathematica and a host of other packages that were recently ported to the 386 using our NDP Fortran and NDP C. Please call (508) 746-7341 for more information.

32-Bit Compilers and Tools

NDP Fortran-386™ and NDP C-386™ Compilers generate globally optimized, mainframe quality code. Both run in 386 protected mode under Unix, Xenix or Phar Lap extended MS-DOS. The memory model employed uses 2 segments, each of which can be up to 4 gigabytes. They generate code for the 80287, 80387, mW3167 or mW1167. Both include high speed EGA graphics extensions written in C that perform BASIC-like screen operations.

- NDP Fortran-386™ Full implementation of FORTRAN-77 with Berkeley 4.2 and Fortran-66 extensions. \$595
- NDP Fortran-386/VM \$695
- NDP Fortran-386/UNIX \$795
- NDP C-386™ Full implementation of AT&T's PCC with MS and ANSI extensions. . . \$595
- NDP C-386/VM \$695
- NDP C-386/UNIX \$795

Phar Lap 386/VMM extensions are supported by the VM releases of NDP Fortran and C. Virtual memory is used automatically by the compilers and the code they generate. This makes it possible to compile and run programs as large as the free space on your hard disk.
Phar Lap Virtual Memory Manager . . \$295
Phar Lap Development Tools \$495

NDP Windows™ — NDP Windows includes 80 functions that let you create, store, and recall menus and windows. It works with NDP C-386 and drives all the popular graphics adapters Library: \$125, C Source: \$250

NDP Plot™ — Calcomp compatible plot package that is callable from NDP Fortran. It includes drivers for popular plotters and printers. Works with CGA, MDA, EGA and VGA . . \$325

NDP/FFT™ — Includes 40 fast running, hand coded algorithms for single and double dimensioned FFTs which take advantage of the 32-bit addressing of the 386 or your hard disk. Callable from NDP Fortran with mW1167 and 80387 support. \$250
387FFT for 16-bit compilers \$250

NDP to HALO '88 Graphics Interface — This module enables you to call graphics routines in HALO '88 from NDP Fortran or C. \$100

MicroWay® 80386 Support (508) 746-7341

Parallel Processing

Videoputer™

The highest performance graphics card on the market. Uses a T800 and TI 34010 in conjunction with a 130 MHz BrookTree DAC. The board comes with one meg of system RAM, one meg of video RAM and a library of graphics primitives. It runs standalone or in conjunction with a transputer network and drives 32 and 64 KHz analog monitors \$4995

Monoputer2™

The world's most popular PC transputer development product now extends the memory available for developing transputer applications from 2 to 16 megabytes. The board features a DMA bus interface for fast I/O.

- Monoputer2 with T414 (0 MB) \$995
- Monoputer2 with T800 (0 MB) \$1495

Quadputer2™

This board for the AT or 386 can be purchased with 2, 3 or 4 transputers and 1 or 4 megabytes of memory per transputer. Two or more Quadputers can be linked together to build networks of up to 100 or more transputers providing mainframe power from \$3495

Transputer Compilers and Applications

These Parallel languages are designed for use with Monoputer2 and Quadputer2.

- Logical Systems Parallel C \$595
- 3L Parallel C or 3L Parallel Fortran . . \$895
- Microfield - Finite element analysis . . \$1600
- ParaSoft: Parallel Environment . . . \$500
- Performance Monitor \$500
- C Source Level Debugger \$500
- T800/NAG™ (See NDP/NAG) \$2750

387BASIC™ — Our 16-bit MS compatible compiler introduces numeric register variables to produce the fastest running 80x87 code on the market \$249

Weitek-Based Coprocessor Boards

mW1167™ and mW3167™ coprocessor boards are built at MicroWay using Weitek components. Each includes an 80387 socket.
mW1167-16 \$895
mW1167-20 \$1095
mW1167 Microchannel-16/20 CALL
3167-20 \$995
3167-25 \$1295
mW3167/80387 Board \$150

Intel Coprocessors and RAM

8087 \$84
8087-2 \$120
80287-8 \$195
80287-10 \$220
80C287A (CMOS) \$280
80387-16 \$350
80387-16SX \$310
80387-20 \$400
80387-25 \$500
287Turbo-12 (for AT compatibles) . . . \$350
RAMPak™ - 1 meg 32-bit memory module for Compaq system memory board . . \$650
256K 100ns DRAM CALL
256K SIMMS CALL
1 MB SIMMS CALL
(All of our Intel coprocessors include 87Test.)

Multi-User Accelerators

MicroWay's AT8™ and AT16™ intelligent serial controllers run 8 to 16 terminals under Unix or Xenix without bogging down your AT, 80386 or PS/2 PC. AT8: \$895 AT16: \$1295

32-Bit Applications

PSTAT-386 — Popular mainframe statistics package. Full version was ported. \$1495
NDP/NAG™ — Features a library of 268 engineering and scientific numerical algorithms. Callable from NDP Fortran \$895
Call for our list of new 32-bit applications.

12 MHz PC Accelerators

FastCACHE-286 12 MHz \$299
SuperCACHE-286 12 MHz \$399
FastCACHE-286 9 MHz \$199

MicroWay

World Leader in PC Numerics

Corporate Headquarters: P.O. Box 79, Kingston, MA 02364 USA (508) 746-7341
32 High St., Kingston-Upon-Thames, U.K., 01-541-5466
USA FAX 508-746-4678 Australia 02-439-8400 Germany 069-75-1428

ical equations. For example, one program finds the definite integral of a function, and another finds the root(s) of an equation. However, every time I work with a new function, I must go back, edit the source code, and then recompile. This gets old fast.

As you can see, I want to enter a mathematical equation while the compiled program is running. I was able to do this using GWBASIC, but the compiled languages do not support the statements that I used in the interpreter.

My question is, Is there some kind of magic subprogram that I can write in assembly language, or in the compiled language itself, that modifies the memory

locations in which the language stores equations?

James M. Pothering
Pottsville, PA

What you're looking for is expression parsing and execution at run time, and, as you've discovered, interpreted languages, by their very nature, usually provide this capability. You've already mentioned GWBASIC; in addition, APL's execute operator lets you move program statements into a character array that is then executed on the fly.

There are a number of places you can investigate for quick help. Dick Poun-tain's "Changing Reverse Polish to In-

fix" (January 1988) describes a simple parser in FORTH. Or, if you find C more palatable, locate a copy of Herbert Schildt's Advanced Turbo C (Osborne/McGraw-Hill, 1987). This book includes a chapter on expression parsing and evaluation, complete with source code that you should be able to graft onto your existing applications.—R. G.

Expanding Floppies

I have an IBM PC with two full-height floppy disk drives. Recently, one of the drives was severely damaged, and I'm thinking of replacing that drive with two half-height disk drives—one 3½-inch

continued

**PC XNET
THE CARD THAT BRINGS X.25 PERFORMANCE
TO YOUR PERSONAL COMPUTER
THINK ABOUT IT!**

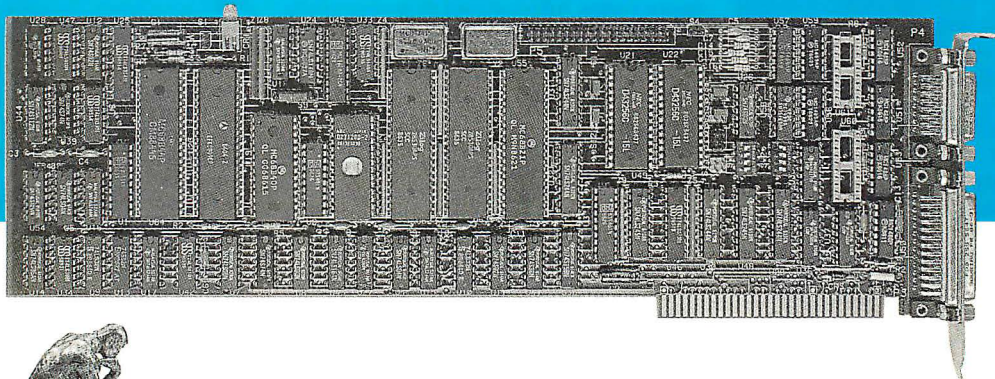

And think about OST, the European leader in the field of private X.25 networks. With two channels supporting speeds at 64 Kbps and 128 virtual circuits each, our PC XNET adapter card brings to personal computers and compatibles a level of performance never reached before.

Easy access via MS DOS, XENIX and NETBIOS makes the PC XNET card the perfect tool for emulating terminals, file servers or providing a gateway to local Area Networks. Fully compatible with many protocols such as X.25, X32 and X.21, the PC XNET card enables computers to be connected to any type of network.

Furthermore, applications programs you develop on the PC XNET card can be transferred to the PC SNET card, OST's ISDN interface card available since October 1988.

So, if you are thinking of X.25 capability for your computer think about OST. In the European league table of packet-switching equipment, we are number one!

OST, SA

Rue du Bas-Village. Z.I. Sud-Est
35515 Cesson-Sévigné Cedex
Tel. : (33) 99.32.50.50.
Fax : (33) 99.41.71.75. Telex : 730 839



OST, Inc

14 225 - F Sullyfield Circle
Chantilly, VA 22021
Tel. : (1) 703 817 0400
Fax : (1) 703 817 0402

Networking Intelligence

SHECOM

SHECOM XT TURBO SYSTEM

8088 10 MHZ CPU
256K RAM
One 360K FDD
Serial/Parallel Ports
84 Keyboard
12" Amber Monitor
Real Time Clock
2 Year Limited Warranty
ONLY \$545.00

SYSTEM 286 BY SHECOM

Start As Low As
\$1495.00

Call Today
And We Will
Help You Configure
One For Your Needs.
You Have

A Choice of 10 MHZ, 12 MHZ,
16 MHZ and 20 MHZ Systems

TOSHIBA LAPTOP CORNER

| | | |
|---------|------------------------------------|--------|
| T1200F | 80C86 CPU 9.54 or 4.77 | \$1395 |
| T1200FB | Same as above W/BACKLIT | \$1625 |
| T1200H | 80C86 CPU W/20 MB HDD | \$2395 |
| T1200HB | Same as above W/BACKLIT | \$2585 |
| T1600 | 80C86 12 MHZ CPU 20MG/BACKLIT | \$3325 |
| T3100E | 80C86 12 MHZ 20MB HDD & GAS PLASMA | \$2995 |
| T3200 | 80C86 12 MHZ 40MB HDD & GAS PLASMA | \$3995 |
| T5100 | 80C86 16 MHZ 2MB RAM 40MG HDD | \$5185 |
| T5200 | 80C86 20 MHZ 40MG HDD | \$6595 |
| T5200 | 80C86 20 MHZ 100MG HDD | \$7675 |

ADD ON CARDS

| | |
|---|----------|
| XT I/O PLUS II S/P.G.CLC. | \$49.50 |
| XT MULTI I/O 1/2 CARD S.P.G.CLC/ FDC 2 DRIVES | \$59.00 |
| XT MULTI I/O SERIAL KIT | \$13.00 |
| XT MULTI I/O W/VIDEO | \$110.00 |
| AT SERIAL/PARALLEL CARD | \$38.50 |
| AT I/O CARD S/P/2ND SERIAL OPTION | \$40.50 |
| AT 2ND SERIAL KIT | \$20.00 |
| RS232 CARD 1 PORT | \$22.00 |
| RS232 CARD 2 PORT (2ND PORT OPTIONAL) | \$30.00 |
| RS232 2ND SERIAL PORT | \$13.00 |
| GAME CARDS | \$14.00 |
| PRINTER CARD | \$16.50 |

VIDEO CARDS

| | |
|---|----------|
| MONO GRAPHICS CARD W/PP | \$55.00 |
| MONO GRAPHICS CARD NO/PP | \$50.00 |
| COLOR GRAPHICS CARD NO/PP | \$48.50 |
| COLOR GRAPHICS CARD W/PP | \$50.60 |
| EGA CARD FULLY MGA, HGA, CGA, EGA AUTO SWITCH | \$155.00 |
| GENOA 4880-7 SUPER HI RES EGA, 800x800 | \$235.00 |
| GENOA 5100-VGA CARD, 800x800 | \$415.00 |
| GENOA 5200-SUPER VGA CARD, 1072x780 | \$540.00 |
| PARADISE EGA 350 CARD 640x350 | \$215.50 |
| PARADISE EGA 480 CARD 640x480 | \$235.50 |
| PARADISE VGA PLUS 800x600 | \$370.00 |
| PARADISE VGA PLUS 16, 16 BIT 256KB MEMORY | \$420.50 |
| PARADISE VGA PROFESSIONAL 512KB MEMORY | \$570.00 |

DRAMS

1 MEG x 1 - 80 NS
1 MEG x 1 - 100 NS
1 MEG x 1 - 120 NS
256K x 1 - 60 NS
256K x 1 - 70 NS
256K x 1 - 80 NS
256K x 1 - 10 NS
256K x 1 - 12 NS
256K x 1 - 15 NS
64K x 1 - 10 NS
64K x 1 - 12 NS
64K x 1 - 15 NS

CALL!

CO-PROCESSORS

8087-3
8087-2/10
80287
80287-8
80287-10
80287-12 NEW ITEM
80387-15
80387-20
80387-25

CALL!

SIMMS / SIPPS

1 MEG X 8 80
1 MEG X 8 100
1 MEG X 8 120
1 MEG X 9 80
1 MEG X 9 85
1 MEG X 9 100
1 MEG X 9 120
258 X 9 80 100 120
258 X 8 80 100 120

CALL!

MONITORS

EGA Monitors
as low as \$445.00
Multisync Monitors
as low as \$475.00
VGA Monitors
as low as \$525.00
Monochrome Monitors
as low as \$80.00

**We carry name brand software too:
LOTUS 123, WORD STAR 2000, WORD PERFECT, VENTURA,
XEROX PUBLISHER, PRINT SHOP, QUATRO, PEACH TREE &
MANY MORE.**

ACCESSORIES & SPECIALS

MOUSES ARE HERE TO STAY!

KRAFT MOUSE Reg \$70 NOW \$58
LOGITECH SUNAL Reg \$85 NOW \$70
LOGITECH BUS MOUSE \$99
LOGITECH HI RES MOUSE \$110
SUMMASKETCH 12x12 \$485
LOGITECH HANDY SCAN \$225
PANASONIC SCANNER 300 x 300 DPI \$1,000

JOIN
THE SHECOM
CLUB FOR ONLY
\$25.00
AND SAVE
\$\$\$

| | |
|---------------------------------|-------|
| SAMSUNG INT 1200 MODEM | \$85 |
| SAMSUNG EXT 1200 MODEM | \$120 |
| SAMSUNG INT 2400 MODEM | \$150 |
| SAMSUNG EXT 2400 MODEM | \$195 |
| SMART ONE INT 1200 MODEM | \$75 |
| MASTER COM INT 2400 | \$140 |
| THE COMPLETE 9600 FAX CARD | \$510 |
| THE COMPLETE FAX 4800 | \$335 |
| NITSUKI FLAT BED FAX Reg. \$850 | \$750 |

SHECOM COMPUTERS, INC.

22755-G Savi Ranch Parkway
Yorba Linda, CA 92686
FAX: (714) 637-6293

Call before you buy and
SAVE! SAVE! SAVE!

Most orders shipped within 48 hours or less
HOURS
M-F 8 a.m.-6 p.m. SAT 11 a.m.-3 p.m.

Ask for our Desktop Publishing
CAD/CAM/CAE System Packages
PACIFIC TIME
Prices subject to
change without notice.

INQUIRIES 714-637-4800

Circle 246 on Reader Service Card (DEALERS: 247)

TECH SUPPORT 714-637-5921

SALES ORDERS CALL

1-800-366-4433

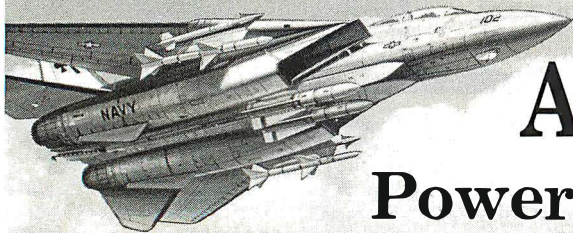

American Power Machines

GRUMMAN F-14A TOMCAT (1972)

This two-seat carrierborne fighter has an advanced radar that can simultaneously track 24 targets and direct attacks against any six of them at a distance of up to 100 miles.

SPECS. 80386

- True Intel 25MHz CPU
- 25MHz Chips & Technology Neat Set
- Deluxe, Digital Tower Chassis/230 Power Supply
- 1MB RAM (640K Base, 384K ROM Shadow)
- 8 I/O Slots (1 32 Bit, 4 16 Bit, 3 8 Bit)
- 1.2 MB F.D.D.
- 1.44 MB F.D.D.
- 150 MB Maxtor ESDI Hard Disk Drive (17 MS)
- 14" Flat Screen Monochrome Monitor & Card
- Serial/Parallel Ports
- 101 Keyboard
- Motherboard Expandable to 8MB/16MB max.

25 MHz

Tower 386 DX-T
\$3,899



SPECS. 386-20 MHz

- True Intel 20 MHz CPU
- 1 MB RAM (640 K Base, 384 ROM Shadow)
- 8 I/O Slots (1 32 Bit, 4 16 Bit, 3 8 Bit)
- 1.1 Interleaved Hard/Floppy Controller
- 1.2 MB Floppy Disk Drive
- 1.44 MB Floppy Disk Drive
- 80 MB Seagate Hard Disk Drive
- Serial/Parallel Ports
- 14" Flat Screen Monochrome Monitor & Card
- 101 Keyboard

\$2,699

SPECS. 386-20 MHz Gas Plasma Portable

- Deluxe 4 Shade Gas Plasma
- 640 x 400 Resolution
- True Intel 80386-20 MHz CPU
- 1 MB RAM (640 K Base, 384 K ROM Shadow)
- Motherboard Expandable to 8 MB
- 1.2 MB Floppy Disk Drive
- 40 MB, 28 MS Hard Disk Drive
- Serial/Parallel Ports
- 80387 Socket
- 3 Expansion Slots Available
- 20 Lbs. with Carrying Case
- RGB/MGP Ext. Output, Ega Optional

\$2,999

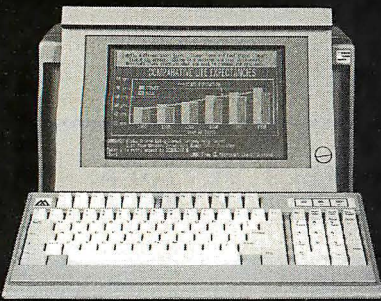

OPTIONS:

| | |
|-----------------------------|-----------------|
| EGA CARD & MONITOR ADD..... | \$350.00 |
| VGA CARD & MONITOR ADD..... | \$499.00 |
| 64 K CACHE OPTION ADD..... | \$475.00 |

CALL FOR LATEST MEMORY UPGRADE COSTS. ALL SYSTEMS FULLY MS, PC DOS COMPATIBLE. RUNS UNIX PC MOS, PIC, NOVELL AND OS/2 MULTI-USER OPERATING SYSTEMS. SYSTEMS MAKE EXCELLENT FILE SERVERS OR HIGH END WORK STATIONS.

SUBSTANTIAL DISCOUNTS FOR VOLUME BUYERS.

MICRO TELESIS

INCORPORATED

1260A Logan Ave., Ste. A2
Costa Mesa, CA 92626

(714) 557-2003 Fax: (714) 557-9729

and one 5 1/4-inch. Can I do this by simply installing a floppy disk controller and connecting the drives to the controller, or is there more to it?

Brian Hong
Glen Ellyn, IL

There's more to it. First, you're looking at installing three floppy disk drives on your system, and that implies some additional controller hardware beyond more drives. Then you've got software problems to contend with. Depending on the age of your XT, it's likely that your BIOS supports only 360K-byte drives, so you'll have to add device drivers (the .SYS files you often see in CONFIG.SYS) to allow your machine to recognize drives of 720K bytes and 1.44 megabytes (the standards for 3 1/2-inch drives). You won't be able to boot from these high-density drives, but if you boot your machine from a hard disk anyway, there's no problem.

A number of vendors provide the necessary controller board hardware, as well as the software device drivers you need to attach 3 1/2- and 5 1/4-inch high-density floppy disk drives to your XT. Check out these companies:

*Manzana MicroSystems, Inc.
P.O. Box 2117
Goleta, CA 93118
(805) 968-1387*

*Micro Solutions, Inc.
132 West Lincoln Hwy.
DeKalb, IL 60115
(815) 756-3411*

*Sysgen, Inc.
556 Gibraltar Dr.
Milpitas, CA 95035
(408) 263-4411*

—R. G./S. W.

SCSI's for Me

I am a retired electrical engineer with some experience with computers (I am rapidly learning more). From what I have read, the SCSI sounds like what I have been looking for to transfer data between various types of computers and some control systems that I am planning.

Where I can find the standard connectors, pin assignments, and data transfer rates for SCSI?

Robert J. Nedreski
Erie, PA

For a detailed look at SCSI, see the three-part Circuit Cellar series ("Adding SCSI to the SB180 Computer") beginning in the May 1986 BYTE.—R. G. ■

IF YOU LIKED OUR AD, YOU'LL LOVE THE BOOK.

On the front gatefold of this magazine, you'll find a 4-page ad about our 386™ systems, 286 systems, laser printers, and low direct-from-the-manufacturer prices. And if you



like what you see, we have a 28-page catalog you'll like even more. Just send the card below, and we'll send you a free copy.

Or call (800) 426-5150. In Canada, call (800) 387-5752.

© 1988 DELL COMPUTER CORPORATION. 386 is a trademark of Intel Corporation.

GET OUR FREE 28-PAGE CATALOG OF DELL COMPUTER SYSTEMS.

This new catalog is the best place to shop for high performance 386 and 286 systems. We also offer a full line of software, peripherals, enhancement products, and networking solutions. Just send this card, and we'll send you a copy.

Name: _____

Title: _____

Company: _____

Address: _____

City: _____ State: _____ Zip: _____

Phone: _____

Please have a Dell representative call me.

- | | |
|---|---|
| 1. Are you a (select one): | 4. How many PCs do you have installed now? |
| A <input type="checkbox"/> End user | A <input type="checkbox"/> 1-10 |
| B <input type="checkbox"/> Consultant | B <input type="checkbox"/> 11-20 |
| C <input type="checkbox"/> Reseller | C <input type="checkbox"/> Over 21 |
| D <input type="checkbox"/> Corporate Purchaser | |
| E <input type="checkbox"/> DP/MIS Manager | 5. How many PCs do you (your company) plan to purchase in the next twelve months? |
| 2. Which products are you most interested in? | A <input type="checkbox"/> 1-10 |
| A <input type="checkbox"/> 286 architecture | B <input type="checkbox"/> 11-20 |
| B <input type="checkbox"/> 386 architecture | C <input type="checkbox"/> Over 21 |
| 3. Are you interested in computer products for: | 6. Is your requirement: |
| A <input type="checkbox"/> Home | A <input type="checkbox"/> Immediate |
| B <input type="checkbox"/> Business | B <input type="checkbox"/> 1-3 Months |
| | C <input type="checkbox"/> Over 3 Months |
| | D <input type="checkbox"/> Info only |

AD CODE 51EE9

GET OUR FREE 28-PAGE CATALOG OF DELL COMPUTER SYSTEMS.

This new catalog is the best place to shop for high performance 386 and 286 systems. We also offer a full line of software, peripherals, enhancement products, and networking solutions. Just send this card, and we'll send you a copy.

Name: _____

Title: _____

Company: _____

Address: _____

City: _____ State: _____ Zip: _____

Phone: _____

Please have a Dell representative call me.

- | | |
|---|---|
| 1. Are you a (select one): | 4. How many PCs do you have installed now? |
| A <input type="checkbox"/> End user | A <input type="checkbox"/> 1-10 |
| B <input type="checkbox"/> Consultant | B <input type="checkbox"/> 11-20 |
| C <input type="checkbox"/> Reseller | C <input type="checkbox"/> Over 21 |
| D <input type="checkbox"/> Corporate Purchaser | |
| E <input type="checkbox"/> DP/MIS Manager | 5. How many PCs do you (your company) plan to purchase in the next twelve months? |
| 2. Which products are you most interested in? | A <input type="checkbox"/> 1-10 |
| A <input type="checkbox"/> 286 architecture | B <input type="checkbox"/> 11-20 |
| B <input type="checkbox"/> 386 architecture | C <input type="checkbox"/> Over 21 |
| 3. Are you interested in computer products for: | 6. Is your requirement: |
| A <input type="checkbox"/> Home | A <input type="checkbox"/> Immediate |
| B <input type="checkbox"/> Business | B <input type="checkbox"/> 1-3 Months |
| | C <input type="checkbox"/> Over 3 Months |
| | D <input type="checkbox"/> Info only |

AD CODE 51EE9

IF YOU CAN'T CALL, WRITE.

On the front gatefold of this magazine, there's a 4-page ad for Dell Computer Systems. It invites you to call our toll-free number, so you

can get our free 28-page catalog. But if you'd rather send this card, that's fine with us. Just fill it out, and we'll get a catalog to you right away.



NO POSTAGE
NECESSARY
IF MAILED
IN THE
UNITED STATES

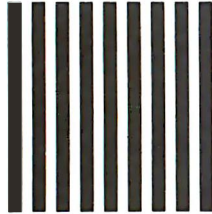

NO POSTAGE
NECESSARY
IF MAILED
IN THE
UNITED STATES



BUSINESS REPLY MAIL

FIRST CLASS MAIL PERMIT NO. 6745 AUSTIN, TEXAS

POSTAGE WILL BE PAID BY THE ADDRESSEE

DELL COMPUTER CORPORATION

Dept. ME
9505 Arboretum Boulevard
Austin, Texas 78759-9969



BUSINESS REPLY MAIL

FIRST CLASS MAIL PERMIT NO. 6745 AUSTIN, TEXAS

POSTAGE WILL BE PAID BY THE ADDRESSEE

DELL COMPUTER CORPORATION

Dept. ME
9505 Arboretum Boulevard
Austin, Texas 78759-9969



CHAOS MANOR MAIL

*Jerry Pournelle answers questions about his column
and related computer topics*

Mrs. Pournelle's Reading Program

Dear Jerry,

After reading your column for many years, I have finally decided to write. Once again, you have made a reference to your wife's reading program, but I see no mention in the Items Discussed box of where to buy it or how much it costs. As a father of school-age children, I would be very interested in obtaining a copy of this program. Is it commercially available, or is it available only to educational institutions? Other fathers in this area would also like to try out the program.

I also enjoyed your comments on Sprint, since it is the first major piece of software I've bought with my own money (my company buys whatever I need in the way of compilers, assemblers, and editors). I would disagree only with your comments on vanilla Sprint. I'm writing this letter using Sprint, and I enjoy it much more than any other word processor I've used. I'm sure that I'll start customizing the program as soon as I have time, but until then, I'm satisfied with what I've got.

Blaine Binkerd
Orem, UT

I'm finally finishing Mrs. Pournelle's Reading Program; see my Computing at Chaos Manor column in the April BYTE for more details.

Thanks for the kind words.—Jerry

Sprint Solutions

Dear Jerry,

The day after I read your account of Sprint's mysterious file conversion error message, Conversion error 37, I had solved the same problem. When converting files, you must execute Sprint from \sprint (or from whatever subdirectory in which you have installed it) and give paths to the input and output files. It seems that for all operations other than file conversion, Sprint can be executed from anywhere and correctly find its files in \sprint.

Your hopping from better to better word processor is fascinating, though your file conversion troubles show there

are occasional penalties. I am happy enough just to have upgraded from DisplayWrite 3.0 (the standard at work) to Sprint 1.0 while keeping the ability to export files the secretaries' word processors can read.

Richard J. Wilcox
West Orange, NJ

Thanks!

Actually, I have backslid. I'm back to Q&A Write again. I'm used to it, and it does just about everything I need to do. But I have Sprint on my hard disk, and it's installed in a DESQview window when I need it.—Jerry

Tampering with Digital Evidence

Dear Jerry,

In your closing comments in Computing at Chaos Manor (October 1988), you expressed concern about courts accepting photographs as evidence in light of the ability to process images digitally. Lawyers, of course, have already given this subject some thought.

I've been working for five years with a company whose original business was color separations but is now "electronic color imaging," or ECI for short. For years, the power players in the publishing, advertising, and packaging industries have been taking advantage of the new digital technology available just now to people who use desktop publishing systems. Digital color retouching and "finessed" image assembly at photographic resolutions are old hat to us.

A couple of years ago, a lawyer contacted a supervisor at my company to have the supervisor testify as an expert witness in a case in which some photographic evidence had the lawyer's client red-handed.

continued

Jerry Pournelle holds a doctorate in psychology and is a science fiction writer who also earns a comfortable living writing about computers present and future. He can be reached c/o BYTE, One Phoenix Mill Lane, Peterborough, NH 03458, or on BIX as "jerryyp."

Circle 47 on Reader Service Card

Four ways to build better programs...

C TOOLS PLUS \$129

Full featured function library.

For Microsoft C and QuickC.

- ◆ TSR support ◆ direct video access
- ◆ VGA and EGA support ◆ windows and menus
- ◆ interrupt service routines ◆ & much more!

C ASYNCH MANAGER \$175

Asynchronous communication manager.

For Microsoft C, QuickC, and Turbo C.

- ◆ speeds to 19.2K baud
- ◆ XON/XOFF protocol ◆ hardware handshaking
- ◆ X Modem file transfer ◆ I/O buffers up to 64K
- ◆ & much more!

POWER SCREEN \$129

Screen I/O manager.

For Microsoft C, Turbo C, Turbo Pascal and QuickBASIC

- ◆ screen painter
 - ◆ virtual screens ◆ data validation
 - ◆ context sensitive help ◆ unlimited screens
 - ◆ definable keys ◆ & much more!
- Includes the Norton Guides Instant Access Program with an online reference database.

Turbo C TOOLS/2.0 \$149

New Version!

Full featured function library.

For Borland's Turbo C 2.0, 1.5 and 1.0.

- ◆ mouse support ◆ virtual windows and menus
 - ◆ context sensitive help screens ◆ TSR support
 - ◆ direct video access ◆ VGA and EGA support
 - ◆ interrupt service routines ◆ & much more!
- Includes the Norton Guides Instant Access Program with an online reference database.

We're Blaise Computing, manufacturers of high quality function libraries designed to reduce the time and technical expertise required for serious applications development.

All of our packages include a comprehensive user reference manual with extensive examples, and sample programs.

We have a full line of products for C and Pascal. For a free brochure or to order call

(800) 333-8087
Fax (415) 540-1938



BLAISE COMPUTING INC.

2560 Ninth Street, Suite 316 Berkeley, CA 94710 (415) 540-5441

Trademarks are property of their respective holders: TurboC, Turbo Pascal, The Norton Guides Instant Access Program, Microsoft C, QuickC, and QuickBASIC.

Technically, if the photograph could be discredited in court, it would not be admitted as evidence. The supervisor, however, didn't like the idea of going into court to discredit a photo that his own trained eyes knew was bona fide. He declined to testify, but that doesn't mean that the issue of admitting photographs in court will go unnoticed.

I am not a lawyer. There are laws regarding what's allowed as evidence and what's not, even as far as photographs

are concerned. Retouching as an art has been with us for years. The crux of the issue today lies in the computer; it's possible to synthesize bogus evidence in photography that leaves no clue of being fake. Textures, features, shadows, even photographic grain (to some degree) can be cloned digitally to produce a completely convincing image. Certainly an adept ECI operator will produce more convincing results than a novice, and the ECI system at hand will determine in

practical terms what kind of image manipulation is possible, but, given enough time and money, one can fake quite amazing things.

If I were asked to be an expert witness, I would also decline, given the situation as mentioned above. But I would not be without major reservations about the larger issues:

1. Publicly, who or what do you believe when you know a picture necessarily has no bearing on reality? Suddenly, photographs, which until recently have been accepted unconsciously as relating directly to reality, are only as truthful as illustration.

2. Legally, can an illustration, photographic or especially digital, be admitted in court? This seems unlikely. The courts will have to assess the technology used to produce the imagery in order to determine the reliability of the evidence in the image. This creates a new burden on the court system, read alternatively as a new advantage for those who are privileged with money, good lawyers, or good imaging abilities.

3. Politically, photo propaganda can reach new heights. In situations in which an audience or society might be naive about what can be done with pictures, there are potential windfalls for those who can manage an ECI project to political advantage.

4. Practically, you could be doing ECI tomorrow on your 80386 or Mac II. These systems are faster than the original mainframes used in ECI shops for years. ECI system manufacturers are working constantly to interface small personal systems, used largely now for design, to their own production systems. Just as you send text on disk for typesetting in Atex format, you can do the same with pictures for output as halftones on a Linotronic or as a color print on a MacDonald-Dettwiler:

Ultimately, publishing will be much faster, more colorful, more interesting, and even more fun to do, but it will not come without the price of responsibility in authorship or without responsible awareness in the audience. Ignoring the issue leaves us at the mercy of those who would alienate or manipulate us all—with our own pictures, of course.

Kurt Heintz
Chicago, IL

Thanks! I only raised the question; clearly, you've got a lot more information than I did.

It does look to be tricky. . . —Jerry ■

ONLY FORTRON COMES WITH ONE FULL YEAR OF SERVICE. FREE. ON-SITE.



NetSet™ 286
NEAT, low 3" profile,
10, 12, 16, 20 MHz

80386 File Server
16, 20, 25, 33 MHz

Desktop 286, 386
10, 12, 16, 20 MHz

When you buy any Fortron 286 or 386-based IBM-Compatible, one full year of service at your site is part of the package. Just call the service hot line, and we'll take care of you from a network of 300 service locations throughout the country.

Because we build our systems right here, you always know exactly who to call for any kind of support you need. And you'll get it, Fast, with no hidden cost.

Here's your chance to be your own PC dealer by dealing directly with Fortron, service and savings, that's the Fortron Difference.

To Order Call Toll Free
800-821-9771

FORTRON

Fortron/Source Corp.

6818-G Patterson Pass Road, Livermore, CA 94550
Telex: 559291 in CA 415-373-1008 Fax: 415-373-1168

If You Want To Talk Fast DBMS Call 1-800-db_RAIMA And Start Screaming

You'll be screaming, all right. db_VISTA III from Raima Corporation will give you the flexibility of a relational DBMS and the lightning speed of the network database model.

Written for C Programmers. C Source Code Available.

The interactive database utilities and outstanding documentation make db_VISTA III easy to learn. Use with popular screen managers and source code application generators (see tech panel) for greater productivity. All applications are portable to VMS, UNIX, OS/2, MS-DOS, MS Windows, even Macintosh.

db_VISTA is Fast. Using benchmarks originated at *PC Tech Journal* Laboratories, db_VISTA III performed 3 to 12 times faster than the average relational database! Call us and we'll send you the results.

Relational and Network Model Technology for Programming Flexibility.

Retrieve a record fast using the relational keyed access method, and all related records can be immediately available using the network database model. You decide how to combine both for best application performance.

db_VISTA III™
Database Development System



db_VISTA: High Performance DBMS

Multi-user, Single User
Fast data access: B-tree indexing, network database model, virtual memory disk caching
Multiple database access
Referential integrity
Automatic recovery
Record and file locking
Database consistency check
Easy-to-use interactive access programs
Data Definition Language patterned after C



db_QUERY - SQL-based Query:
Relational interface to db_VISTA databases

db_REWISE - Database Restructure Program: Redesign your database

Add WKS Library for Lotus 1-2-3:
Fast C and BASIC interface to Lotus, dBASE and others

Operating Systems: VMS, ULTRIX, UNIX System V, BSD 4.2, SunOS, QNX, XENIX, OS/2, MSDOS, Macintosh, MS Windows

C Compilers: VAX, UNIX, XENIX, SunOS, Microsoft, Lattice, TurboC, LightspeedC, MPW

LANs: 3Com, Novell, LifeNet, Banyan, and any other MS-DOS NetBIOS-compatible LAN. AppleShare and network-independent versions.

Other compatible C Tools:
Pro™ source code application generator.
Screen managers: C-scape™, Vermont Views™, DataWindows™

No Royalties. That's been our policy since 1984, when db_VISTA was first introduced. Save thousands of dollars per installation!

SQL Support. Retrieve data quickly with SQL-based db_QUERY. Use it ad hoc or build it into applications. Report writer capabilities included.

db_VISTA III Puts You in Some Fast Company.

Thousands of C programmers in over 50 countries worldwide use db_VISTA III. At companies with names like APPLE, ARCO, AT&T, Citicorp, EDS, Federal Express, Proctor & Gamble, Hewlett Packard, IBM, NASA...

Call for Screaming-Fast Answers. You don't have to wait for database performance this good. Call our toll-free number for more information and quick response to any questions you have concerning db_VISTA III. And ask about consulting, training and development services available to Raima customers.

Call 1-800-db_RAIMA
(That's 1-800-327-2462)

RAIMA™
CORPORATION

BY59

Raima Corporation 3245 146th Place S.E., Bellevue, WA 98007 USA (206)747-5570 Telex: 6503018237 MCI UW FAX: (206)747-1991 Texas: (214) 231-3131
International: U.K.: (0992) 500919 Germany: 07127/5244 Switzerland: (01)725 04 10 France: (1)47 727777 Benelux: (02159)47 758 Sweden: (013)124780
Italy: (011) 8124040 · (045) 584711 Denmark (02) 887249 Norway (02) 448855 Australia: (02) 959 5122 Japan: (03) 473-7432 Taiwan: (02) 511-3277 © 1989

CMO...Your Nationwide Source

PC 100



BASIC SYSTEM CONFIGURATION:

- Intel 8088, 10 MHz Speed
- 640K, Expandable to 1640K
- 360K Floppy Disk Drive
- Floppy Disk Drive Controller
- Clock Calendar with Battery Backup
- 150 Watt Power Supply
- MS-DOS & GW-Basic
- 4 Half Height Front Storage Slots
- 102-Key Switchable Keyboard
- 3-In-One Video Adapter

MONITOR:

- 14" Color RGB
- Tilt & Swivel Base
- 80 x 25 Display
- Green Text Switch

SYSTEM PRICE
\$869

AMIGA

| | |
|-------------------------------|-------|
| Aegis Development | |
| Draw Plus 2000 | \$159 |
| Lights, Camera, Action | 52 |
| Videoscape 3D | 139 |
| Cinemaware | |
| TV Sports | 32 |
| Electronic Arts | |
| Deluxe Paint II | 89 |
| Photo Lab | 99 |
| Epyx Software | |
| XJ-500 Joystick | 15 |
| Gold Disk Software | |
| Professional Draw | 139 |
| Lattice | |
| Lattice C 5.0 | 189 |
| Micro Systems Int. | |
| Raw Copy V1.3 | 44 |
| Micro Systems Software | |
| The Works Platinum | 189 |
| New Tek Inc. | |
| Digi-View Gold | 149 |
| Digi-Paint | 39 |

| | |
|--------------------------|------|
| Sub-Logic Corp. | |
| Flight Simulator II | \$39 |
| WordPerfect Corp. | |
| WordPerfect | 189 |

MACINTOSH

| | |
|------------------------|------|
| Olympia | |
| NP-30 Mac 150cps | 289 |
| Seikosha | |
| SP-1000AP Mac | 239 |
| Everex | |
| EMAC 20 Deluxe 20MB | 595 |
| EMAC 60T 60MB Backup | 895 |
| PCPC | |
| 45MB SCSI Hard Drive | 999 |
| Cornerstone | |
| SinglePage Display SE | 759 |
| DualPage Display SE | 1259 |
| Magnavox | |
| 9CM080 14" VGA Display | 519 |
| RasterOps | |
| 1948S Trinitron | 3395 |
| Sigma Designs | |
| PageView SE | 849 |
| LaserView II | 1899 |

New Image Technology

| | |
|------------------------------|--------|
| MacScan Pro Sheetfeed | \$1399 |
| MacScan Pro Flatbed | 1789 |
| Practical Peripherals | |
| Mac 2400 Stand Alone | 239 |
| Shiva | |
| NetModem V2400 | 429 |

MONITORS

| | |
|--------------------------|-----|
| Amdek | |
| Video 210 Amber | 85 |
| Video 410 TTL Monochrome | 145 |
| Video 432 VGA Monochrome | 169 |
| Color 732 VGA Color | 399 |
| Cornerstone | |
| SinglePage Display | 899 |
| Magnavox | |
| 7BM623 12" TTL Amber | 89 |
| CM8762 14" Comp/RGB | 249 |
| 9CM053 14" HiRes EGA | 369 |
| 9CM062 14" VGA Display | 349 |
| 9CM082 14" VGA Display | 399 |
| NEC | |
| JC-1403 Multisync IIA | 529 |
| Packard Bell | |
| PB-1272 12" TTL Mono | 79 |
| PB-1472 14" TTL 132 Col. | 109 |
| PB-1422EG 14" HiRes EGA | 359 |



POLAROID
Palette EGA Plus
\$2199

| | |
|-------------------------------|------|
| Seiko Instruments | |
| CM-1430 14" VGA | 629 |
| Taxan | |
| 119 12" Composite Amber Mono. | 89 |
| 770+ MultiVision Display | 499 |
| Wyse Terminals | |
| WY-30, 50, 60 | Call |
| Zenith | |
| ZFM-1490 14" VGA Analog | 619 |

MULTIFUNCTION

| | |
|---------------------------|-----|
| ATD-ZuckerBoard | |
| Color Half Card | 79 |
| Monochrome Graphics Adpt. | 79 |
| AST | |
| Six Pak Plus Board | 119 |
| VGA Plus Adapter | 389 |

Boca Research

| | |
|------------------------|-------|
| TopHat 128K Expansion | \$129 |
| BocaRam/AT 0-4MB Board | 149 |
| Boca MultiEGA | 189 |
| DCA | |
| Irma 2 3278 Board | 729 |



5th GENERATION
Logical Connection
256K \$419

| | |
|----------------------------|------|
| Emerald | |
| 3XTwin 5251 Local Emulat. | 669 |
| Everex | |
| Magic I/O AT Par/Ser | 59 |
| Ram 3000 Deluxe 0-3MB Bcl. | 89 |
| Micro Enhancer EGA | 169 |
| Hercules | |
| Graphics Card Plus | 179 |
| Intel | |
| AboveBoard 2 Plus w/OK | 319 |
| AboveBoard PS/286 w/512K | 419 |
| AboveBoard Plus w/512K | 429 |
| AboveBoard Plus I/O 512K | 579 |
| Inboard 386/PC 80386 CPU | 589 |
| 8087 IBM PC/XT CoP. | 95 |
| 80287-8 IBM XT 8MHz CoP. | 219 |
| 80387-16 16MHz 80386 | 399 |
| Orchid Technology | |
| ProDesigner VGA | 329 |
| TinyTurbo 286 | 279 |
| Paradise | |
| AutoSwitch EGA 480 Adpt. | Call |
| Video 7 | |
| Vega VGA Adapter | 285 |
| FastWrite Video Adapter | 349 |

STORAGE DEVICES

| | |
|----------------------------|-----|
| American Power | |
| 450AT + UPS Backup | 439 |
| ATD-ZuckerBoard | |
| Tandy 30MB HardCard | 479 |
| Everex | |
| Floppy Stream 40 40MB Int. | 359 |
| Excel Stream 40T 40MB Int. | 529 |
| Miniscribe | |
| 8425 20MB 3 1/2" 40Msec | 259 |
| 3650 40MB 5 1/4" 61Msec | 349 |
| 6085 70MB 5 1/4" 28Msec | 599 |
| Mountain Computer | |
| TD-4340 40MB Int. Tape | 319 |

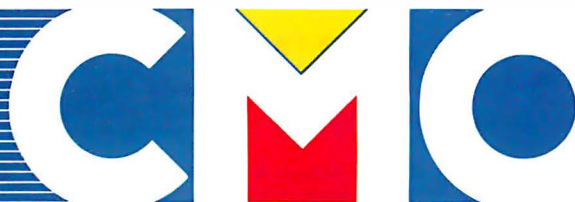

Your Source for Hardware, Software & Peripherals

For Quality Computer Products.

| | |
|-----------------------------|-------|
| Mountain Computer | |
| TD-8000 80MB Ext. Tape | \$445 |
| Plus Development | |
| 20MB HardCard | 549 |
| Seagate | |
| ST-225 20MB w/cont | 249 |
| ST-238 30MB w/cont | 279 |
| Sysgen | |
| Bridge-File 5 1/2" External | 249 |
| SmartImage 60MB Internal | 479 |
| QIC-File 60MB External | 599 |
| Omni Board Controller | 79 |

COMPUTERS

| | |
|----------------------------|------|
| Amstrad | |
| PPC-640 Portable | 849 |
| AST | |
| Premium 286 Model 80 | 1459 |
| Compaq | |
| Deskpro & Portable 286/386 | Call |
| NEC | |
| Multimate Laptops | Call |
| PC-TOO | |
| 640K 10MHz 8088 Desktop | 699 |
| 512K 12MHz 80286 Desktop | 999 |
| Sysgen | |
| ProSystem 12MHz w/40MB | 1999 |
| Toshiba | |
| T1000 8088 Laptop | 789 |
| T1200 Floppy/HrdD Lpt | Call |
| Zenith | |
| 80286/386 Desktops | Call |
| SuperSport 20MB w/Modem | 1999 |



ZENITH
SuperSport 20MB
w/Modem \$1999

COMMUNICATIONS

| | |
|----------------------------|-----|
| Anchor | |
| 6480 C64/128 1200 Baud | 99 |
| 520 ST520/1040 1200 Baud | 129 |
| 2400 Baud External | 169 |
| Atari | |
| XMM301 XL/XE 300 Baud | 44 |
| SX-212 ST Modem | 89 |
| Avatex | |
| 1200 HC External | 99 |
| 2400 Baud External | 179 |
| Everex | |
| Evercom 12 1200 Baud Int. | 79 |
| Evercom 24 2400 Internal | 149 |
| Evercom 24E+ 2400 Bd. Ext. | 199 |
| Hayes | |
| SmartModem 1200 Baud | 289 |
| SmartModem 2400 Baud | 429 |
| Intel | |
| 2400B Classic Internal | 249 |
| Murata | |
| ML200 Facsimile | 779 |
| Panasonic | |
| FX-89 Fax Board | 699 |

This Month's Featured Product:

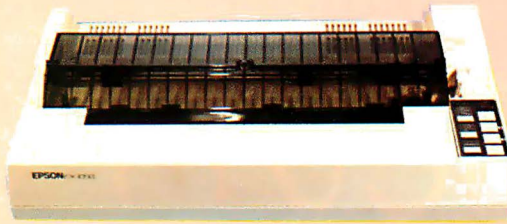

EPSON FX-1050
264 CPS, 132 Column **\$445**

| | |
|------------------------------|--------|
| FX-505 Hi-Res Scanner | \$1049 |
| Practical Peripherals | |
| 1200 Baud Internal | 69 |
| 1200 Baud Stand Alone | 109 |
| 2400 Baud Stand Alone | 189 |
| 2400 Baud Internal | 159 |



ANCHOR
2400 Baud Lightning
f/i \$109

| | |
|----------------------------|-----|
| Sharp | |
| FO-220 Facsimile Machine | 999 |
| Supra | |
| 2400AT 2400 Baud Atari | 169 |
| The Complete PC | |
| Complete FaxBoard 4800 | 269 |
| Complete Answering Machine | 249 |

PRINTERS

| | |
|---------------------------|------|
| Alps | |
| ASP-1000 9-Pin Flatbed | 189 |
| Allegro 24 24-Pin Flatbed | 349 |
| Brother | |
| M-1709 240cps, 132 Col. | 389 |
| M1724L 24-Wire, 132 Col. | 569 |
| HR-20 20cps Daisywheel | 359 |
| HR-40 40cps Daisywheel | 599 |
| Epson | |
| LX-800 180cps, 132 Col. | 165 |
| FX-850 264cps, 80 Col. | Call |
| LQ-500 180cps, 24-Wire | 279 |
| LQ-850 330cps, 24-Wire | Call |
| LQ-950 264cps, 24-Wire | Call |
| LQ-1050 330cps, 132 Col. | Call |
| Hewlett-Packard | |
| 2225 Thinkjet | 339 |
| NEC | |
| P2200 Pinwriter 24-Wire | 349 |
| P5200 Pinwriter 265cps | 579 |
| Okidata | |
| ML-182+ 180cps, 80 Col. | 249 |
| ML-320 300cps, 80 Col. | 359 |
| ML-390 270cps, 24-Wire | 499 |
| Panasonic | |
| KX-P1180 192cps, 80 Col. | 189 |

| | |
|----------------------------|-------|
| KX-P1191 280cps, 80 Col. | \$259 |
| KX-P1124 192cps, 24-Wire | 349 |
| KX-P1524 24-Wire, 132 Col. | 579 |
| Star Micronics | |
| NX-1000 144cps, 80 Col. | 169 |
| NX-1000 RainBow Color | 239 |
| NX-2400 24-Wire, 80 Col. | 369 |
| Toshiba | |
| ExpressWriter 311 | New |

MS-DOS SOFTWARE

| | |
|--------------------------|-----|
| Ashton-Tate | |
| dBase IV | 479 |
| MultiMate Advantage II | 289 |
| Borland | |
| Paradox R-Database | 439 |
| Quattro | 149 |
| Central Point | |
| PC Tools Deluxe | 49 |
| DAC Software | |
| DAC-EASY Accounting | 59 |
| 5th Generation | |
| FastBack Plus | 99 |
| Fox Software | |
| Fox Base + Development | 199 |
| IMSI | |
| OptiMouse w/Dr. Halo III | 79 |
| Logitech | |
| C7 Mouse w/Software | 79 |
| ScanMan Scanner | 199 |

| | |
|----------------------------|-------|
| Lotus Development | |
| Lotus 1-2-3 | \$299 |
| MECA | |
| Managing Your Money | 119 |
| Meridian Technology | |
| CarbonCopy Plus 5.0 | 119 |
| Microsoft | |
| Serial or Buss Mouse | 109 |
| MSC | |
| OmniMouse | 49 |
| Peter Norton | |
| Advanced Utilities | 79 |
| Peachtree | |
| Complete Accounting | 169 |
| Quarterdeck | |
| DESQView 2.02 | 79 |
| Server Technology | |
| EasyLan Starter Kit | 179 |
| Software Publishing | |
| 1st Choice 3.0 | 89 |
| 1st Publisher 2.0 | 79 |
| Professional Write 2.0 | 179 |
| The Complete PC | |
| HandScan For PC | 179 |
| Traveling Software | |
| Lap-Link Plus | 84 |
| WordPerfect Corp. | |
| WordPerfect 5.0 | 219 |
| Xerox | |
| Ventura Publishing 2.0 | 449 |

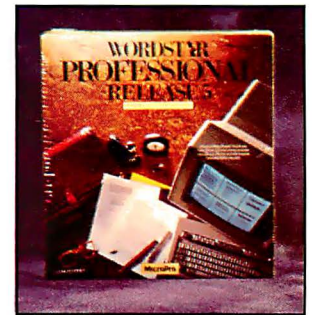

MICROPRO
Wordstar Pro 5.0
\$199



Your Source for Hardware, Software & Peripherals

In U.S.A.

800-233-8950

In Canada call: 800-233-8949

All Other Areas call: 717-327-9575 Fax call: 717-327-1217
Educational, Governmental and Corporate Organizations
Call toll-free: 1-800-221-4283

CMO, 101 Reighard Ave., Dept. A1, Williamsport, PA 17701

Over 400,000 SATISFIED CUSTOMERS • MAJOR CREDIT CARDS ACCEPTED

POLICY: Add 3% (minimum \$7.00) shipping and handling. Larger shipments may require additional charges. Personal and company checks require 3 weeks to clear. For faster delivery, use your credit card or send cashier's check or bank money order. Credit cards are not charged until we ship. Pennsylvania and Maryland residents add appropriate sales tax. All prices are U.S.A. prices and are subject to change. All items are subject to availability. Defective software will be replaced with the same item only. Hardware will be replaced or repaired at our discretion within the terms and limits of the manufacturer's warranty. We cannot guarantee compatibility. All sales are final and returned shipments are subject to a restocking fee. We are not responsible for typographic or photographic errors.



A105

Concurrent DOS 386

Think small in a big way

When you think multiuser/multitasking, think Concurrent™ DOS 386, the big name in small systems from Digital Research, architects of the first standard operating system for personal computers. Now, Concurrent DOS 386 allows multiple users to share peripherals, files and applications, using serial terminal workstations linked by RS-232 cables to the system. It's fast, reliable and economical.

The big news today is small systems

Concurrent DOS 386 meets the increasing demands placed on small systems by supporting multiple DOS programs on both the system console and attached terminals. You can run popular programs such as Lotus® 1-2-3®, dBase® III, WordPerfect® and many more, with full math coprocessor support. The system runs up to 255 tasks simultaneously, with full intertask communications and byte-level record, file and device locking.

For people who hate waiting in line

Concurrent DOS 386 brings you all the remarkable speed and power of the Intel® 80386 processor. A prioritized pre-emptive scheduler allows task execution

and intertask communication by several users at near full processor speed while letting some tasks "interrupt" others according to the needs of each user.

A small system with a big memory

Concurrent DOS 386 gives you access to four gigabytes of linear physical memory. Its powerful memory paging capability fully supports the Expanded Memory Specification with no additional hardware or software.

Menus at a touch

Now you can create and customize menus, while programmable function keys let you condense complex commands to a single keystroke. The file manager runs standard operating system functions, plus you have an on-line help facility, text editor and support for DOS-based device drivers.

Multiuser color graphics

Now with the introduction of the newest member of the Concurrent DOS family, Concurrent DOS 386/Multiuser Graphics Edition, your demands for high-resolution EGA bit-mapped graphics in the workstation environment can

be met. Take advantage of advanced technology allowing you to run popular DOS-based graphics programs on individual workstations as well as on the system console without sacrificing system performance. Ask us about this exciting new version of Concurrent DOS 386.

All you have to remember is Concurrent DOS 386

Concurrent DOS 386 from Digital Research is the name to remember when it comes to 386 technology. The power and versatility of Concurrent DOS 386 are giving a new meaning to the word multiuser.

**CALL DIGITAL RESEARCH AT
1-800-443-4200 AND ASK FOR OUR
CONCURRENT DOS PROGRAMMER
INFORMATION KIT.**

**CONCURRENT DOS 386:
SHARING THE SYSTEM AFFORDABLY**

Digital Research and the Digital Research logo are registered trademarks, and Concurrent is a trademark of Digital Research Inc. Other product names are registered trademarks or trademarks of their respective owners. Specifications are subject to change without notice. Copyright © 1988, Digital Research Inc. All rights reserved.

 **DIGITAL RESEARCH®**

BOOK REVIEWS

Advanced OS/2 Programming

by Ray Duncan

Microsoft Press, Redmond, WA: 1989, 781 pages, \$24.95

Reviewed by G. Michael Vose

When IBM tried to set the microcomputer world on fire with its new OS/2 operating system in the spring of 1987, it focused on OS/2's ability to run more than one program at a time and on the promise of huge RAM memories. A while later, the emphasis shifted to the graphical user interface, the Presentation Manager, and its benefits to a computing public crying for application "ease of use."

Early OS/2 programmers learning version 1.0 were stuck with writing so-called kernel applications—programs that used an Application Program Interface (API) based solely on the OS/2 kernel. The kernel is the part of OS/2 that manages memory, files, timers, multitasking, interprocess communications, and, through device drivers, hardware resources. Only later did a Presentation Manager API arrive that allowed programmers to create applications in a graphical environment.

Since then, programmers have worked hard learning the OS/2 ropes. The OS/2 world of tomorrow will likely be peopled with two classes of software developer: the kernel expert and the Presentation Manager guru. Each class will create slightly different applications.

The kernel experts will write utility programs, program development tools, communications programs, and LAN management tools. The Presentation Manager experts

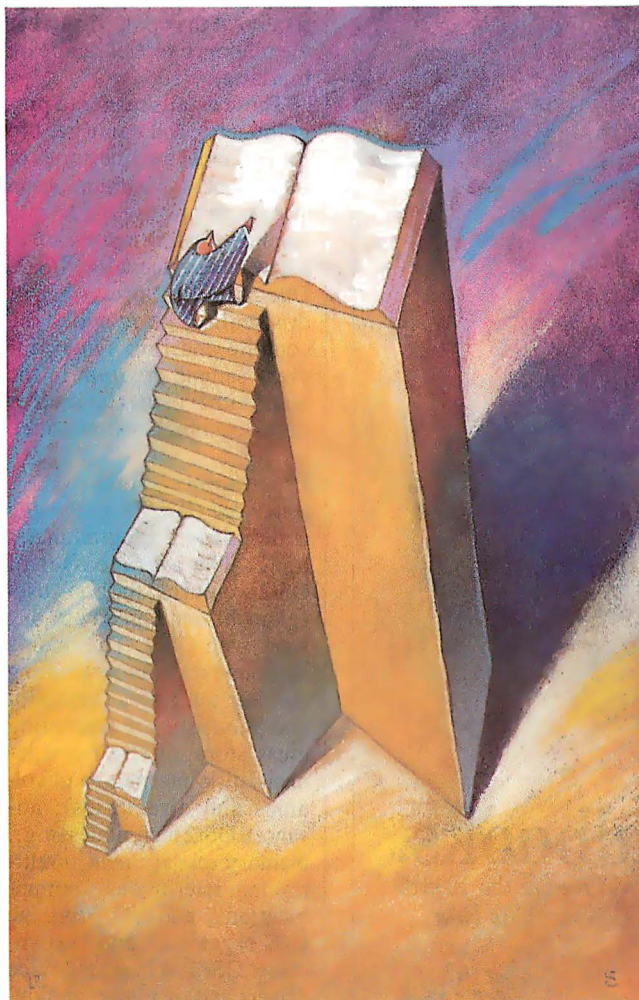

will write paint/draw/illustrator programs, desktop publishing systems, and spreadsheets and database managers richly endowed with features.

The kernel wizards will eventually come to use *Advanced OS/2 Programming* as their bible. This indispensable guide to the inner workings of the OS/2 kernel is the most important book on the subject to date. Many of the program-

mers who are currently wrapped up in the complexities of the Presentation Manager may ignore this book, which is heavily sprinkled with assembly language code examples, in favor of volumes containing C source code examples of Presentation Manager programs. But every OS/2 programmer will eventually turn to this book for its lucid explanations of OS/2 es-

oterica, such as writing filters, device drivers, and device monitors.

Detailed Descriptions

The previously published books on OS/2 programming have provided a little more detail with each succeeding "generation." The first wave of books, including those by Microsoft's Gordon Letwin and IBM's Ed Iacobucci, outlined OS/2 design goals and syntax details. The next wave, which brought books by Michael Young and Dave Cortesi, provided explanations of OS/2 based on some real programming experience. Ray Duncan's book provides yet another increase in the level of detail, all based on actual programming experience with OS/2. For example, Duncan's explanation of the use of the `VioPopUp/VioEndPopUp` services is twice as long as Young's in *Programmer's Guide to OS/2*. Duncan's description warns against using these services except for true background processes. His warning derives from the dramatic changes in screen mode that these services make possible, which can trouble users.

The level of detail here goes to the heart of kernel programming. Duncan explains exactly how an OS/2 program gets loaded into the computer, and his memory maps detail each step of the process. He gives full-syntax explanations of each component of a module definition file. He even explains the structure of file allocation table (FAT) organization for programmers who might be coming to OS/2 with no MS-DOS background. There is also a section that explains the use of Microsoft's OS/2 programming tools, including Macro Assembler (MASM), C 5.1, LINK, the

continued

ALSO REVIEWED

Algorithmics: Theory and Practice

Operating Systems Design: The XINU Approach

A Visual Introduction to SQL

Image Processing.

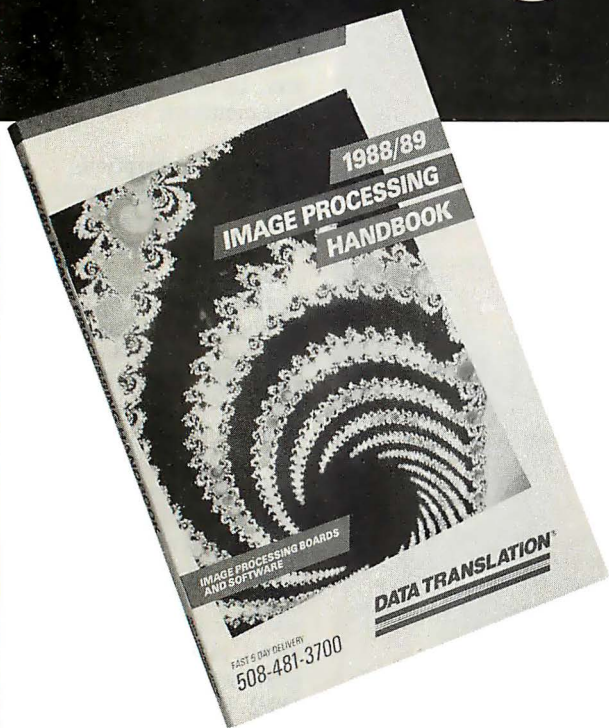

Free Handbooks.

Data Translation invites you to receive the 1988/89 Image Processing Handbook and the 1989 New Products Handbook.

The Book

1988/89 Image Processing Handbook - featuring full product information and 28 documentary stories on image processing and array processing.

The Booklet

1989 New Products Handbook - supplement to our 1988/89 Image Processing Handbook provides new product information, complete pricing and documentary stories.

R.S.V.P. to receive an edition

1-800-221-6071

DATA TRANSLATION®

100 Locke Drive, Marlboro, MA 01752-1192 USA

utilities Cref, Make, and Bind, and the Library Manager. This attention to detail permeates every subject and section of the book, including the reference section (more on this later).

These details matter to programmers. You can't get too excited about the fine points of interprocess communication if you can't figure out how to compile and link a program in a new environment like OS/2. Duncan never loses sight of this reality; he provides the compile and link syntax for every sample program in the book, either in the text itself or in the example's source code.

Programmer's Book

Advanced OS/2 Programming is definitely a programmer's book. The average user of OS/2 won't find the book useful in his or her day-to-day work with OS/2. The book's sections tackle programming the user interfaces (keyboard and mouse); programming mass storage (file management, disk internals, and volumes and directories); advanced OS/2 techniques (e.g., memory management, multitasking, interprocess communications, and I/O privilege level segments); and customizing OS/2 (filters, device drivers and monitors, and dynamic link libraries).

Pulling together more than two years of experience with OS/2, Ray Duncan wrote *Advanced OS/2 Programming* from a unique perspective: As an acknowledged expert on MS-DOS, having written *Advanced MS-DOS Programming* and edited the massive *MS-DOS Encyclopedia*, Duncan explains and evaluates many of OS/2's capabilities from an MS-DOS programmer's slant. He describes tasks that an MS-DOS programmer would perform and explains why some MS-DOS programming techniques work while others do not. For example, in the chapter on file management, Duncan explains why the MS-DOS technique of forcing a disk update

by closing and reopening a file handle, or by making a copy of the handle and then closing it, is both inefficient and unnecessary in OS/2.

But this MS-DOS insider's view of OS/2 is only one of the book's interesting features. Duncan even talks about how OS/2 calls affect high-level language program portability. C programs that make direct calls to API services for file management instead of using C run-time library calls will be faster and more compact but less portable. By definition, a kernel application is likely to be less portable than a Presentation Manager program. The various APIs being written to put a Presentation Manager face on Unix will guarantee that developers who want maximum portability will write to the Presentation Manager API. Nevertheless, Duncan's discussion of how the use of certain kernel API functions make C code less portable was instructive.

Programmers will also appreciate the many program examples in this book. All the sample code is offered in assembly language, with duplicate C source code for about a third of the programs. The listings are often nifty utilities that you can use to perform some meaningful task under OS/2: A *Whereis* utility searches a hard disk to find the location of a file; a *Snap* utility uses a device monitor to eavesdrop on the keyboard for a key sequence that tells the program to take a "snapshot" of the current screen and store it in a disk file; and a *Dump* utility displays the hexadecimal values of a section of memory. All the code in the book is available on disk from Microsoft Press at additional cost.

There's even some humor here. For example, in one sample program designed to read mouse events and display the mouse position, the program terminates by displaying the words *Have a Mice Day*. In the reference guide, one of the mouse API services defines

continued

October 27, 1988

Mr. Charles Bostwick
Bostwick Parker Company
13644 148th Avenue
Detroit, Michigan 49684

Dear Mr. Bostwick:

The results of the computer simulation are in, and you'll find them quite fascinating. Here is an interesting surprise: the greatest sales potential exists with product three. What's more, the largest sales will number three. What's more, the largest sales will result from Europe and the Far East, not the United States.

Bostwick Parker Co.
New Product Sales Projections

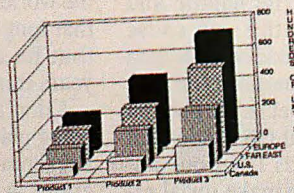

These sales projections take into account the requested in the model. Specifically, the greatest sales potential was reduced to reflect the simulation was reduced to reflect the simulation in the

October 27, 1988

Mr. Charles Bostwick
Bostwick Parker Company
13644 148th Avenue
Detroit, Michigan 49684

Dear Mr. Bostwick:

The results of the computer simulation are in, and I think you'll find them quite fascinating. Here is an interesting surprise: the greatest sales potential exists with product number three. What's more, the largest sales will result from Europe and the Far East, not the United States.

Bostwick Parker Co.
New Product Sales Projections



These sales projections take into account the requested in the model. Specifically, the greatest sales potential was reduced to reflect the simulation was reduced to reflect the simulation in the

CAN YOU SPOT THE \$700 DIFFERENCE?

One of the nearly identical samples you see above was printed with the HP Laserjet Series II. The other is from the Mannesmann Tally® MT905. Both are reprinted here exactly as they came out of the printers.

But what might surprise you is the rather dramatic difference in the manufacturers' suggested retail prices.

The Mannesmann Tally laser is \$700 less. Yet it offers the same high quality output, lowers operating costs 25 percent, and prints at six pages per minute.

The MT905 comes with the same resident type fonts as HP, accepts standard HP font cartridges, and lets you choose optional memory upgrades from one to four megabytes.



MT905 Specifications

- Technology: scanning laser.
- Print Speed: 6-pages per minute.
- Resolution: 300 x 300 dpi.
- Emulations: HP Series-II, [optional emulations: Epson, IBM® Proprinter, & Diablo 630.]
- Standard I/Os: Serial & parallel.
- Memory: 512K. [upgrades: 1, 2, & 4 megabytes.]
- Typefaces: Courier medium & bold, line printer, accepts standard HP font cartridges or any downloadable font in HP-format, 6-resident fonts + 2 font cartridge slots.
- Paper Handling: 250-sheet input & output bins. Manual feed handles single sheets, envelopes, transparencies, and labels.
- Workload: 4,000 pages-per-month.
- Suggested Retail: \$1,995.

For more convenient paper handling, the universal paper cassette holds letter, legal, and international sizes, plus up to 15 standard envelopes. You can choose face-down output to keep long documents in the right order. And the manual feed lets you print labels or transparencies.

So any way you figure, the answer still comes up the same. The Mannesmann Tally laser looks perfect. And so does the price.

For the name of your nearest dealer, call the toll-free number listed below.

**MANNESMANN
TALLY**

1-800-843-1347

Ext. 334

Epson and IBM are registered trademarks.

PROTECT INTELLIGENCE WITH INTELLIGENCE



SOFTWARE PROTECTION KEYS BY PROTECH

PROTECH KEYS:

- are totally transparent to the end user
- allow unlimited back up copies
- free up disk drives
- do not interfere with peripheral operations
- are easy to install
- protect software developers' revenues
- assembler based routines (not drivers)
- encrypted routines
- physically unique hardware KEYS
- sophisticated software installation advice
- provide the highest level of protection available

THE MEMORY KEY

The MEMORY KEY is a programmable software protection device. Each byte of memory can be addressed in groups or individually. Possible applications for the MEMORY KEY include:

- modular package control
- serialization
- customization
- access control to PCs
- demo control
- software leasing
- updating modules in the field
- any "counter" operation

For a demonstration package or additional information, please write or call:

1-800-843-0413

PROTECH MARKETING, INC.
4905 Pine Cone Drive • Building 10
Durham, North Carolina 27707
(919) 490-4970 FAX (919) 490-4974

THE KEY
The KEY provides effective software protection while insuring customer satisfaction. The KEY is a random response device which is designed for identically reproduced software packages.

units of mouse movement as "mickeys."

A Unique Reference

Unlike the earlier book by Gordon Letwin, *Advanced OS/2 Programming* seldom waxes theoretical about OS/2. Even when explaining why OS/2 acts as it does under a given set of circumstances, Duncan's explanations lean more toward the practical. For example, he warns you that multiple threads within a process can access the same file by using its file handle and cautions that this can cause onethreadtoread or writedata to a different part of a file than the thread expects. He goes on to explain that OS/2 does not protect threads from one another or try to make serial requests among threads; programmers must handle this detail themselves. Later, in a section on using semaphores, he explains how you write code to protect threads from one another.

The reference section uses a unique approach to presenting the essential facts about each API service. Icons, including one that features a circle with a diagonal line through it—an international symbol for "no"—superimposed over the letters PM for Presentation Manager, tell you at a glance if a given API service works with the Presentation Manager, if it was added to version 1.1 of OS/2, if it can be called from the I/O Privilege Level (ring 2), if it is a Family API service, or if the service is an advanced Vio function designed to work with the Presentation Manager.

In addition, the reference section provides a complete guide to the DosDevIOctl and the DevHlp device functions that are essential to writing device drivers. The appendixes contain a complete description of the OS/2 load module format—the so-called new EXE format—including a listing of the NEWEXE.HC header file that defines the structure of the OS/2 load module tables and a description of module-

definition file syntax. A glossary and a 20-page index round out the references.

Highly Recommended

Duncan offers a wealth of information in this volume, and he manages to pack it into a very readable 495 pages of main text. His writing style evolved from his early days of writing for computer magazines, and it remains very easy to take. His two-plus years of experience with OS/2 make him one of just a few people in the world who have used OS/2 that long. The understanding that he developed in those years shows.

I don't think the emphasis being placed today on writing Presentation Manager programs will diminish the importance of solid references on the OS/2 kernel. Likewise, it will always be important to write some programs in assembly language to attain maximum performance.

In these pages last July, I recommended books by Gordon Letwin and Ed Iacobucci for any OS/2 programmer's library. Since then, I haven't seen a book I'd recommend more than *Advanced OS/2 Programming*.

BRIEFLY NOTED

Algorithmics: Theory and Practice by Gilles Brassard and Paul Bratley, Prentice-Hall, Englewood Cliffs, NJ: 1988, 361 pages, \$42 (hardcover). In the 21 years that have passed since the publication of volume 1 of Donald Knuth's immortal *Art of Computer Programming*, the in-depth analysis of algorithms has progressed from an arcane art taught in only a few computer science departments to a required part of any accredited college computing curriculum. Moreover, the development and use of efficient computer algorithms has diffused outward from computer science into areas as diverse as quantitative management,

continued

OS/2 ~~or~~ DOS? MultiBoot is the answer.

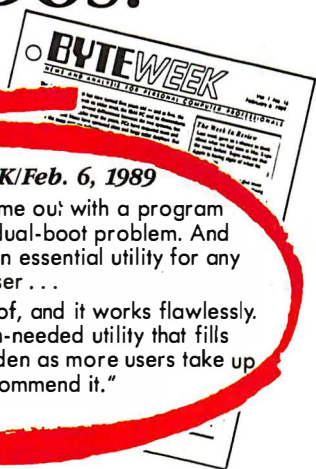

From *BYTEWEEK*/Feb. 6, 1989

"... Bolt Systems has come out with a program that does away with the dual-boot problem. And at \$49, MultiBoot will be an essential utility for any OS/2 user..."

MultiBoot is simple, foolproof, and it works flawlessly. It's an example of a much-needed utility that fills a niche, a niche that will widen as more users take up OS/2. We recommend it."

Not all DOS programs work in the OS/2 compatibility box. MultiBoot lets you install both systems in your computer. MultiBoot works with DOS versions 3.0-4.01 up. And OS/2 versions 1.0 and 1.1.

TO ORDER:

Send \$49.95* + \$3.00 shipping and handling (check or money order) to:

MultiBoot, Bolt Systems, Inc.
4340 East-West Highway
Bethesda, Maryland 20814

or call 1-301-656-7133.
FAX: 1-301-907-8736, and order by Visa/Mastercard. Specify 3.5" or 5.25" diskettes.
Ask about our volume discounts



*Maryland residents add 5% sales tax.

The Cool Machine Cometh



OKIDATA introduces a line of PC modems that run so cool they're guaranteed for 5 years.

Our new 1200, 2400 and 2400 *Plus* PC modems are built around a very simple fact: the cooler they run, the longer they last.

That's important in any modem, and it's vital in the case of an internal board. That's why we engineered a special chip that does the work of three ordinary chips. It also generates less heat—and consumes 50% less power—than the leading brand. Which is why we back our modems twice as long as they do.

But reliability on the inside comes as no surprise when the OKIDATA name is on the outside.

We have over a century of experience in telecommunications all over the world. And you'll see it in everything we make, from tank-tough printers to award-winning PC modems to a full line of high-speed modems.

To see our new "cool machines" in person, visit your OKIDATA dealer. Or call 1-800-OKIDATA for the name of the dealer nearest you.

Circle 192 on Reader Service Card

PC DIGEST

... gave five stars to our 1200 bps modem and top-rated our 2400 bps modem.

PC WORLD

... gave our 2400 their coveted "Best Buy" title.

Registered Trademarks: OKIDATA, Oki America, Inc.,
Marque déposée de Oki America, Inc.
Trademarks: *PC Digest*, National Software Testing
Laboratories, Inc.; *PC World*, PC World Commu-
nications, Inc.

OKIDATA®
an OKI AMERICA company

We put business on paper.

Some views on why the NEC MultiSync

There's a lot more to the new MultiSync® 3D monitor from NEC than meets the eye. Because instead of making one monitor for each



graphics board, we've developed a monitor that enhances

the performance of the modes on practically any board.

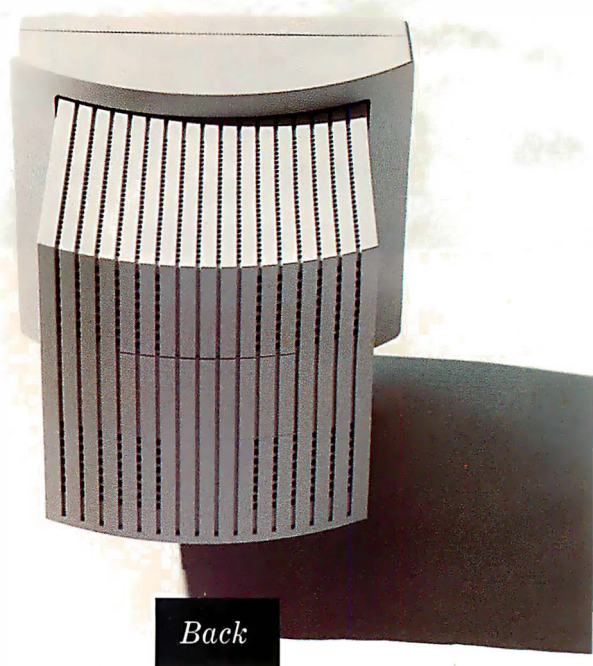

With its new microprocessor-controlled digital tuning system, MultiSync 3D can adjust to a given video standard with a precision matched only by a few high-end single-frequency monitors.

Making it perfectly compatible with virtually all systems and boards. From 8514A, SuperVGA and Mac II to VGA, EGA, MDA and

3D is the new monitor standard.

CGA. For an incredible maximum resolution of 1024 x 768.

What's more, MultiSync 3D is equally compatible with you and your workplace. There are upfront controls, for easier access. A 14" non-glare screen on a tilt-swivel base, for more comfortable viewing. And, as you can see, there's even a full 360 degree design.

The way we see it, MultiSync 3D

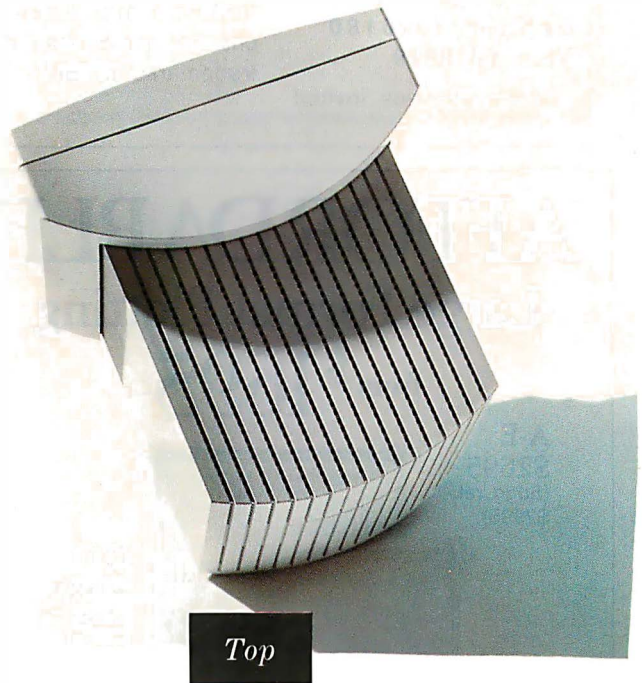
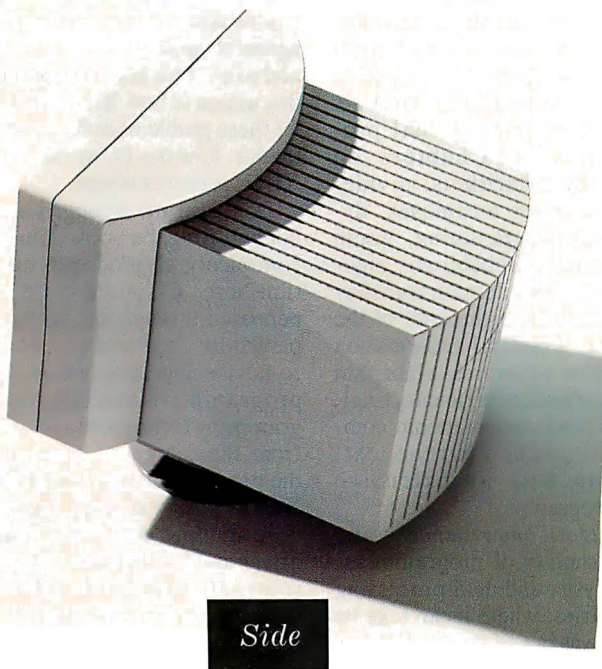

has dramatically raised the

standards by which all other color monitors will be judged.

MultiSync is a registered trademark of NEC Home Electronics (USA) Inc.

For literature, call 1-800-826-2255. For technical details call NEC

Mac II is a registered trademark of Apple Computer, Inc.

Home Electronics (USA) Inc. 1-800-FONE-NEC.

©1989 NEC Home Electronics (USA) Inc.

NEC

MAY 1989 • BYTE 57

IF YOU DESIGN ADD-IN BOARDS FOR THE NEW
IBM PS/2 SYSTEM YOU NEED OUR

MICROCHANNEL 4860 C INTERFACE CHIP

Just some of the Functions implemented:
Program. Option Select * 32 Bit Data Bus Contr.
Multi Device Arbitration * Channel Check Indicator
Memory and I/O Transfer contr. * Wait State Log.
16 Programmable Address Levels.
It comes in a 68 pin PLCC and is fabricated in 1.5u
CMOS, only consumes 150mW. You can replace 10
to 20 TTL devices, a board real estate saving of
20 to 65 sqcm. A reduction of board development
time of some weeks is realistic. Only requires 2
additional 74LS245 for 16 bit systems, or 4 for
32 bit systems. The chip costs US\$ 15,- in
quantities of 5000 and is available now.

EDC GmbH, Taunusstr.51
8 MUNICH 40 W. GERMANY

Tel. (89) 3507076

Fax. (89) 3596180

Tx. 5212599

IBM, PS/2 and Micro-
channel are registered
trademarks of IBM

Dealer inquiries invited

AFFORDABLE

Large Format Plotting

from \$1695

A-E
\$2695
(Sugg. ret.
\$2995)



C-D
\$1695
(Sugg. ret.
\$2295)

Made in USA

A-D
\$2295
(Sugg. ret.
\$2695)

ECONOMICAL: \$1000 less than other
large format plotters without sacrificing
quality.

MULTIPLE MEDIA SIZES: As small as
8½ x 11 or as large as 36 x 48. Eliminates
the need for a second plotter.

REPEATABILITY AND RESOLUTION:
.002 assures quality suitable for the most
demanding applications including PCB
artwork.

SPEED: 10" per second assures excellent
drawing throughout.

DM/PL is a registered trademark of Houston Instrument

VACUUM PAPER HOLD DOWN: Guarantees
perfect registration every time.

CALL FOR FREE SAMPLE PLOT

(415) 490-8380

International Distributors Invited

ZERICON

40491 Encyclopedia Circle, Fremont, CA 94538

civil engineering, epidemiology, banking and finance, and cryptography—in short, into every field in which computers have become indispensable tools. Programmers today, whether formally trained or not, are expected to recognize when and where code efficiency is crucial and to be able to make an informed choice as to the type of algorithm to use.

Algorithmics: Theory and Practice is an excellent self-contained guide to the study of efficient algorithms. Although it was written as a college textbook (a purpose that it will undoubtedly serve well), the authors have put together a collection of information that includes almost every important category of algorithm that's available to today's working professional programmers. Chapters on greedy algorithms, divide-and-conquer techniques, dynamic programming, graph searches, probabilistic algorithms, and domain transformations form the core of the book. Practical information on data structures, algorithm specification, efficiency analysis, and computational complexity round out the text, along with an extensive bibliography.

Algorithmics should be on the shelves of programmers, analysts, and data-processing libraries, where it can take its place as one of the most up-to-date and well-written books in its field.—Eric Bobinsky

Operating Systems Design: The XINU Approach by Douglas Comer and Timothy Foswood, Prentice-Hall, Englewood Cliffs, NJ: 1988, 502 pages, \$46. XINU is a recursive acronym that stands for "XINU is not Unix." PC-XINU (the version described in this book) is also not an operating system in the same sense as MS-DOS; that is, you do not boot your computer in the XINU environment. PC-XINU exists as a library of routines that you link into whatever C program you in-

tend to run under PC-XINU. When you execute the program, PC-XINU then takes over and functions independently of MS-DOS (PC-XINU routes all system-level calls around DOS to the BIOS). Within this framework, you can experiment with the fundamentals of a multiprocessing operating system: Your program can "fork" multiple concurrent processes; tasks can communicate with one another through semaphores and message passing; and so on.

Operating Systems Design: The XINU Approach is not an overview text, so don't look here for analyses of how various popular operating systems handle issues of memory management, process scheduling, and so on. This book is rather a discussion of how XINU tackles these problems and, in particular, how the PC version of XINU is implemented.

Don't get me wrong: I am not belittling the book. You'll find plenty of good information here. C source code is peppered throughout, accompanied by clear explanations, so novice and intermediate C programmers can lift programming techniques and tips from the examples. Also, in the process of describing PC-XINU's lowest-level hardware routines (e.g., the disk driver and the keyboard input routine), this book offers working examples for the IBM PC assembly language programmer. I was particularly pleased with the brief but useful description of the disk and video system interrupt calls. If you've ever wondered how to reroute interrupt vectors, you'll find working examples here. And PC-XINU's technique of using assembly language only when necessary provides guidance for writing interrupt drivers in high-level language, shepherded by small, easy-to-understand assembly routines.

As a nice plus, chapter 14 covers PC-XINU's elementary window management system (with the emphasis on

continued

NEW AVOCET C™ FOR MICROCONTROLLERS— A BREAKTHROUGH IN SPEED AND QUALITY.

Introducing Avocet C.™ Fast, optimizing cross-compilers that can cut microcontroller development time in half—without sacrificing code quality.

From concept to code in a fraction of the time.

Programming in C lets you concentrate on end results, not annoying details—so you get more done, faster. And rapid compilation takes the frustration out. But for microcontrollers, you need more than speed. You need tight, high-quality code.

That's why we spent two years field-testing and perfecting Avocet C for both speed and quality. We built in three separate phases of optimization—for object code tight enough for real applications. And we integrated Avocet C with an assembler package that's mature in its own right—not an afterthought. So you can still work magic at the bits-and-bytes level.

Avocet C saves you time in all phases of development. Our run-time library is extensive—no need to write the routines yourself. You'll arrive at bug-free code faster, thanks to LINT-like type checking. And your program's useful life is extended, because you can recompile for other target chips.

Testing is easier, too. Avocet C is ANSI-standard—so you can test generic parts of your program with host-resident systems like Microsoft Quick-C™ and Codeview.™ And when you're ready for hardware-specific testing, Avocet's AVSIM Simulator/Debugger tests microcontroller code right on your PC.

An excellent value.

Just \$895 buys Avocet C for your favorite chip: Intel 8051 or 8096, Hitachi 64180, or Zilog Z80—with more to follow. And Avocet C includes the latest version of AVMAC—Avocet's superfast, professional assembly-language development package. *(If you're already a registered AVMAC owner, you can upgrade to Avocet C for only \$595.)*

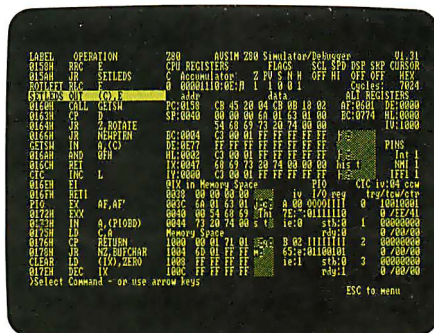

The AVSIM Full-Screen Display

AVOCET

SYSTEMS, INC.®

THE SOURCE FOR QUALITY PERSONAL μ P DEVELOPMENT TOOLS.

Circle 29 on Reader Service Card

Free Catalog

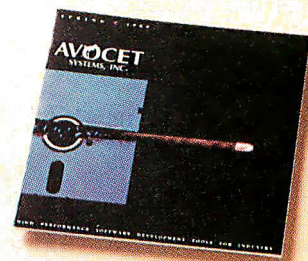

Call Toll-Free 800-448-8500*

For your free Avocet catalog—to order—or for more information about Avocet C and other Avocet products.

The best technology— responsive, personal service.

Avocet offers a powerful, comprehensive approach to microcontroller development.

Avocet development tools put the most advanced technology at your fingertips. The Avocet staff stands ready to give you complete support—including technical assistance—on a moment's notice. And we'll ship your order in 48 hours or less.

Call 800-448-8500. Discover how Avocet can speed up your next project.

Avocet Systems, Inc., 120 Union Street
P.O. Box 490BP, Rockport, Maine 04856
*In Maine, or outside U.S., call (207) 236-9055
TLX: 467210 Avocet CI, FAX: (207) 236-6713

© 1988 Avocet Systems, Inc. All rights reserved. Quick-C and Codeviewer trademarks of Microsoft Corp. Logo and name Avocet are registered trademarks of Avocet Systems, Inc.

AMX 86

KADAK's
engineers bring
years of practical real-time
experience to this mature

MULTI-TASKING SYSTEM (version 2.0)

for the IBM® PC, PC/XT and PC/AT

- No royalties
- IBM PC DOS® support
- C language support
- Preemptive scheduler
- Time slicing available
- Source code of the C interface and device drivers is included
- Intertask message passing
- Dynamic operations:
 - task create/delete
 - task priorities
 - memory allocation
- Event Manager
- Semaphore Manager

AMX86™ operates on any 8086/88, 80186/88, 80286 system.

Demo package \$25 US
Manual only \$75 US
AMX86 system \$2195 US
(shipping/handling extra)

KADAK Products Ltd.

206-1847 W. Broadway
Vancouver, B.C., Canada
V6J 1Y5



Telephone: (604) 734-2796
Telex: 04-55670

Also available for 8080, Z80, 68000

“elementary”). Given the growing acceptance of windows as primary components of an operating system (observe the Macintosh Finder, Sun's SunView, and OS/2's Presentation Manager), it's good to see a description of windows in an operating-system book.

For an additional \$79.95, Prentice-Hall will send you PC disks containing all the software that's described in the book. You'll need either Microsoft C with MASM and LINK, or Turbo C. Appendix 2 is the PC-XINU programmer's manual and includes sample programs and command-line scripts for compiling, linking, and executing a XINU application. This appendix also summarizes all the XINU system calls.

My only real complaint with the book is that there's an unusual amount of white space throughout. In many places, more than 75 percent of a page has been left empty; this seems to occur in the vicinity of many of the longer listings—perhaps it was a typesetting problem.

The greatest strength of *Operating Systems Design: The XINU Approach* is that it offers a working example of the fruits of modular design and an eye toward portability. Versions of XINU are now running on everything from the PDP-11 to the Mac II to—of course—the IBM PC. Working examples are always helpful, so if the operating-system section of your library is heavy on theory and needs some balancing on the application side, look for *Operating Systems Design: The XINU Approach*.—Rick Grehan

A Visual Introduction to SQL by J. Harvey Trimble Jr. and David Chappell, John Wiley & Sons, New York: 1989, 270 pages, \$24.95. This book is written for the nontechnical user, but it is valuable to even the seasoned user of relational databases. Although there has been a great deal of talk about SQL (pronounced “sequel,”

the acronym for Structured Query Language) in the past few months, little has been written about its use. SQL has become the de facto standard for interfacing application programs with relational database systems. It is also becoming the widely used “quick and dirty” method for users to retrieve data from database systems. SQL is found in dBASE IV, Paradox, Informix, Oracle, and most multiuser relational database systems.

A Visual Introduction to SQL is especially appealing to those of us who are visually oriented learners. Clear and simple diagrams help to build the reader's understanding of the many possibilities of SQL queries. (Metaphor Computer Systems in Mountain View, California, originated the diagramming method.)

The authors use only a single database made up of five tables (data files) for all the examples throughout the text. They give numerous examples of each concept as they build the reader's ability to retrieve complex, multiple table joins in a single line of SQL. One line of SQL is equivalent to dozens of lines of dBASE programming.

Although the authors cover the querying principles well, they offer little more than cursory treatment of database construction and indexing. They never mention the most common Unix relational DBMS, Informix, or the numerous 4GL products.

A Visual Introduction to SQL is a helpful text for understanding querying, but it is far from a complete reference on SQL.—Ben Smith ■

CONTRIBUTORS

G. Michael Vose is a coeditor of *OS Report: News and Views on OS/2*. **Eric Bobinsky** works on computational plasma physics at NASA's Lewis Research Center in Cleveland, Ohio. **Rick Grehan** is director of the BYTE Lab. **Ben Smith** is a BYTE technical editor.

presenting

PADS

SUPERSTATION

for TOTAL INTEGRATION

Now you can obtain complete cradle-to-grave performance from your personal computer CAD system when performing electronic packaging design. From schematic capture to printed circuit design, to 100% completion autorouting capabilities, it's all here. We already offer the best selling PCB design software in the industry, and now you have one more reason you should be using PADS: *Total Integration*. Call our Sales Hotline today to receive a free Integrated Evaluation Package for the PADS-SUPERSTATION.

call today!

In MA: (508) 486-8929
Outside MA: (800) 255-7814

CAD
Software, Inc.
119 Russell St.
Littleton, MA 01460

**NOW! Larger Data Sets.
Upgrades Available**

MODEL FITTING RESULTS FOR: YIELD

| INDEPENDENT VARIABLE | COEFFICIENT | STD. ERROR | T-VALUE | SIG. LEVEL |
|----------------------|--------------|------------|---------|------------|
| CONSTANT | | | | 0.0018 |
| time | -3977.847583 | 747.932209 | -5.3185 | 0.0016 |
| time^2 | 17.862499 | 3.288094 | 5.4325 | 0.0386 |
| temp | -0.021469 | 0.008136 | -2.6386 | |
| temp^2 | 44.997502 | 9.614533 | 4.6802 | |
| time*temp | -0.124651 | 0.032546 | -3.8300 | |
| | -0.0975 | 0.020297 | -4.8037 | |

SE = 2.029674 MAE = 1.173868
 0.000000 0.000000
 R-SQ. (ADJ.) = 0.7865
 Previously: 0.0000
 12 observations fitted, forecast(s) computed for 0 missing val. of dep

FURTHER ANOVA FOR VARIABLES IN THE ORDER

| SOURCE | SUM OF SQUARES | DF | MEAN SQ. |
|-----------|----------------|----|-----------|
| time | 15.3890909 | 1 | 15.389091 |
| time^2 | 15.6011921 | 1 | 15.601192 |
| temp | 1.0765657 | 1 | 1.076566 |
| temp^2 | 60.4298606 | 1 | 60.429861 |
| time*temp | 95.0625000 | 1 | 95.062500 |
| Model | 187.559209 | 5 | |

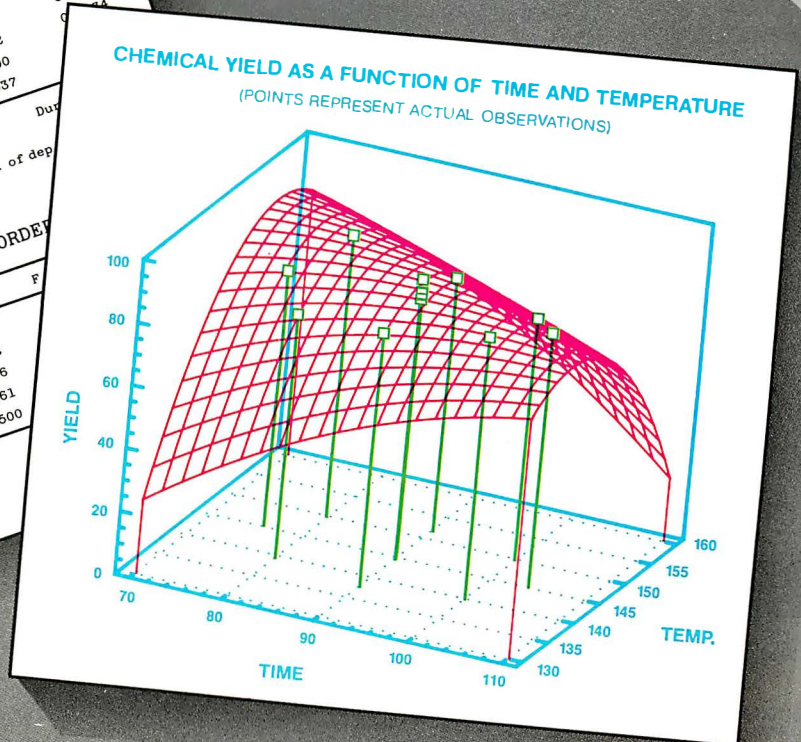

BRAINS & BEAUTY

STATGRAPHICS®. Sophisticated Data Analysis and Gorgeous Graphics — In An Easy-to-Use PC Statistics Package.

Get the best of both worlds with STATGRAPHICS — sophisticated data analysis *and* a dazzling array of graphics in an easy-to-use PC statistics package.

Powerful Statistics. Realize the full potential of your analytical skills. STATGRAPHICS gives you over 250 statistical procedures including ANOVA, regression analysis, quality control procedures, experimental design, multivariate techniques, nonparametric methods, exploratory data analysis, forecasting, time series analysis, and more.

Incredible Graphics. Turn the "Ho-Hum" into the "Ah-Ha!" STATGRAPHICS includes over 50 types of graphs that allow you to analyze your data visually and communicate your results brilliantly!

Easy To Learn and Use. Enter your data using our full-screen editor, or import data directly from your ASCII, dBASE®, Lotus®, or DIF files. STATGRAPHICS is completely menu-driven and includes online HELP, a self-paced tutorial,

handy reference cards, and a user's guide complete with examples and sample data sets. No wonder *InfoWorld* said STATGRAPHICS "makes interactive data analysis and knock-your-socks-off graphics easy."

Why compromise? Get the power of sophisticated data analysis *and* gorgeous graphics with STATGRAPHICS — all for only \$895.* For more details or to order today, call:

(800) 592-0050 ext. 400

**In Maryland, (301) 984-5123;
 Outside the U.S., (301) 984-5412 for
 the name of the dealer nearest you.**

Ask about our money-back guarantee!

STSC STSC, Inc.
 2115 East Jefferson Street
 Rockville, MD 20852

Circle 253 on Reader Service Card

* Suggested retail price in U.S. and Canada. International prices vary. STATGRAPHICS, dBASE, and Lotus are registered trademarks of Statistical Graphics Corp., Ashton-Tate, and Lotus Development Corp., respectively.

Programmer's Paradise offers an



WE'LL MATCH NATIONALLY ADVERTISED PRICES.

386 PRODUCTS

| | LIST | OURS |
|-------------------------|------|------|
| 386 ASM/LINK | 495 | 399 |
| 386MAX | 75 | 66 |
| 386MAX PROFESSIONAL | 129 | 115 |
| 387BASIC | 249 | 229 |
| 80386 UR/FORTH | 350 | 315 |
| F77L-EM/32 | 895 | 829 |
| High C 386 | 895 | 799 |
| HTBasic 386 | 800 | 719 |
| NDP C-386 | 595 | 529 |
| NDP FORTRAN-386 | 595 | 529 |
| Professional Pascal 386 | 895 | 799 |

ASSEMBLY LANGUAGE

| | LIST | OURS |
|--------------------------|------|------|
| Advantage Disassembler | 295 | 279 |
| ASMFLOW | 100 | 89 |
| Incra | 180 | 149 |
| MS Macro Assembler | 150 | 99 |
| OPTASM | 125 | 105 |
| Sourcer w/BIOS Source | 140 | 125 |
| Turbo Assembler/Debugger | 150 | 112 |
| Visible Computer: 80286 | 100 | 89 |

BASIC LANGUAGE

| | LIST | OURS |
|-------------------------|------|------|
| db/LIB | 139 | 121 |
| FaceIt | 99 | 90 |
| GraphPak Professional | 149 | 127 |
| MS BASIC/6.0 | 295 | 199 |
| ProBas | 135 | 125 |
| ProBas Telecomm Toolkit | 75 | 70 |
| ProBas Toolkit | 99 | 94 |
| ProScreen | 99 | 94 |
| QuickBASIC | 99 | 69 |
| QuickComm | 139 | 119 |
| QuickPak Professional | 149 | 129 |
| QuickPak Scientific | 79 | 70 |
| QuickWindows Advanced | 139 | 125 |
| SoftCode | 79 | 70 |
| True BASIC | 100 | 69 |
| Turbo Basic | 100 | 75 |

C COMPILERS

| | LIST | OURS |
|--------------------------|------|------|
| AZTEC C Commercial | 499 | CALL |
| High C | 595 | 549 |
| Lattice C 3.4 | 450 | 289 |
| Microsoft C | 450 | 299 |
| QuickC 2.0 | 99 | 69 |
| Turbo C 2.0 | 150 | 112 |
| Turbo C 2.0 Professional | 250 | 185 |
| WATCOM C | 295 | 269 |
| Zortech C + w/source | 150 | 129 |
| | 250 | 209 |

C CODE GENERATORS

| | LIST | OURS |
|----------------------------|------|------|
| DATABOSS Applic. Generator | 399 | 379 |
| Matrix Layout | 150 | 139 |
| PRO-C | 495 | 459 |
| w/Workbench | 595 | 569 |

C COMMUNICATIONS

| | LIST | OURS |
|--------------------------|------|------|
| BreakOut II | 125 | 99 |
| C ASYNCH MANAGER | 175 | 137 |
| Essential Communications | 185 | 121 |

| | LIST | OURS |
|----------------------------|------|------|
| Greenleaf Comm Library | 229 | 169 |
| Greenleaf ViewComm | 495 | CALL |
| Lattice Communication Lib. | 250 | CALL |

C LIBRARIES/UTILITIES

| | LIST | OURS |
|----------------------------|------|------|
| C TOOLS PLUS/5.0 | 149 | 115 |
| C Utility Library | 199 | 139 |
| CxPERT | 395 | 335 |
| Greenleaf Business Mathlib | 239 | 169 |
| Greenleaf Functions | 209 | 155 |
| Greenleaf SuperFunctions | 265 | 189 |
| Multi-C | 249 | 229 |
| PCYACC | 395 | 359 |
| PC-lint | 139 | 101 |
| PforCe | 395 | 229 |
| TimeSlicer | 295 | 279 |
| w/source code | 1000 | 899 |
| Turbo C TOOLS/2.0 | 129 | 99 |
| vLIB | 99 | 89 |
| WKS Library | 195 | 189 |

C SCREENS/WINDOWS

| | LIST | OURS |
|-----------------------------|------|------|
| C-Scene | 299 | 282 |
| w/Look & Feel | 399 | 379 |
| C-Worthy w/forms and source | 495 | 439 |
| Greenleaf DataWindows | 295 | 229 |
| Greenleaf MakeForm | 125 | 90 |
| HI-SCREEN XL | 149 | 129 |
| IAM | 750 | 679 |
| JYACC FORMAKER | 495 | 449 |
| Panel Plus | 495 | 395 |
| Vermont Views | 395 | CALL |
| w/source code | 790 | CALL |
| Vitamin C | 225 | 162 |
| VCScreen | 149 | 109 |
| WINPRO2 | 250 | CALL |

COBOL LANGUAGE

| | LIST | OURS |
|-----------------------------|------|------|
| Micro Focus | 1800 | 1499 |
| COBOL2 w/Toolset | 900 | 749 |
| COBOL2 Toolset | 149 | 129 |
| Personal COBOL | 900 | 599 |
| MS COBOL | 995 | 849 |
| Realia COBOL | 1145 | 979 |
| w/RealMENU | 950 | 799 |
| RM/COBOL | 1250 | 1059 |
| RM/COBOL-85 | 395 | 349 |
| RM/Screens | 400 | 375 |
| SCREENIO | 395 | 359 |
| XDB-COBOL (Realia) | 595 | 509 |
| XDB-COBOL (Microsoft/Focus) | 595 | 509 |

DBASE DEVELOPMENT

| | LIST | OURS |
|------------------------------|------|------|
| CLARION | 695 | 589 |
| Clear + | 200 | 169 |
| Clipper | 695 | 439 |
| dBASE III Plus | 695 | 399 |
| dBASE IV | 795 | 485 |
| dBASE IV Developer's Edition | 1295 | CALL |
| dBFast/DOS | 119 | 109 |
| DEBUG | 195 | 179 |
| dGE | 195 | 179 |
| Flipper | 195 | 169 |
| FoxBASE+ | 395 | 249 |
| FoxBASE+/386 | 595 | 399 |

| | LIST | OURS |
|--------------------------|------|------|
| Friendly Finder | 99 | 90 |
| Genifer | 395 | 259 |
| Integrated Dev. Library | 149 | 129 |
| Magic PC | 195 | 169 |
| Paradox 3.0 | 725 | 543 |
| PC/Focus | 1295 | 778 |
| QuickSilver | 599 | 369 |
| R&R | 150 | 129 |
| w/Clipper/FoxBASE module | 199 | 179 |
| R:Base for DOS | 725 | 529 |
| Scrimage | 149 | 119 |
| Silver Comm Library | 189 | 159 |
| Silver Paint Library | 100 | 90 |
| Sycero db | 695 | 669 |
| Tom Rettig's Library | 100 | 80 |
| UI Programmer 2 | 595 | CALL |

DEBUGGERS

| | LIST | OURS |
|----------------------|------|------|
| 386 DEBUG | 195 | 145 |
| Periscope I/512K | 795 | 675 |
| Periscope III 10 MHz | 1395 | 1255 |
| Periscope IV | CALL | CALL |
| Sherlock | 195 | 179 |
| Softprobe II/TX | 395 | 359 |

DOCUMENTATION

| | LIST | OURS |
|--------------------|------|------|
| Clear+ (C) | 200 | 169 |
| EasyFlow | 150 | 125 |
| FLOW CHARTING II + | 229 | 207 |
| Source Print | 97 | 80 |
| Tree Diagrammer | 77 | 70 |

EDITORS

| | LIST | OURS |
|---------------|------|------|
| BRIEF | 195 | CALL |
| w/dBRIEF | 275 | CALL |
| Epsilon | 195 | 151 |
| KEDIT | 150 | 120 |
| MKS VI | 149 | 127 |
| Multi-Edit | 99 | 90 |
| Norton Editor | 75 | 70 |
| PC/EDT + | 295 | 269 |
| Pi Editor | 149 | 129 |
| SLICK Editor | 195 | 155 |
| SPF/PC | 245 | 185 |
| VEDIT PLUS | 185 | 115 |
| Vq | 270 | CALL |

FILE MANAGEMENT

| | LIST | OURS |
|-----------------------|------|------|
| Apex Database Library | 395 | CALL |
| Btrieve | 245 | 185 |
| Btrieve/N | 595 | 459 |
| CBTREE | 159 | 135 |
| C-Index for MSC | 195 | 175 |
| C-Index for Turbo C | 100 | 90 |
| C-Index Plus | 395 | 329 |
| C-ISAM | 225 | 209 |
| c-tree | 395 | 318 |
| d-tree | 495 | 395 |
| r-tree | 295 | 241 |
| c-tree/r-tree | 650 | 523 |
| CQL | 225 | 199 |
| w/PASS | 395 | 349 |
| dbc III | 250 | 169 |
| dbc III PLUS | 500 | 399 |
| db.FILE | 395 | 322 |
| db.RETRIEVE | 395 | 322 |
| Essential B-Tree | 99 | 89 |
| w/source | 198 | 149 |
| FABS Plus | 195 | 172 |
| Network Version | 295 | 269 |
| Informix Products | CALL | CALL |
| Netware SQL | 595 | 489 |
| pBase | 149 | 135 |
| Turbo Programmer/C | 549 | 449 |
| XDB-C | 395 | 359 |
| XQL | 795 | 599 |
| Xtrieve | 595 | 459 |
| Report Executive | 149 | 109 |

FORTRAN LANGUAGE

| | LIST | OURS |
|---------------------------|------|------|
| F77L | 477 | 429 |
| F77L-EM/32 | 895 | 829 |
| GRAFLIB | 175 | 159 |
| Grafmatic | 135 | 119 |
| Grafmatic/Plotmatic | 240 | 219 |
| GRAFPLUS | 50 | 45 |
| Lahey Personal FORTRAN 77 | 95 | 89 |
| MS FORTRAN | 450 | 299 |
| PLOTHI | 175 | 159 |
| PLOTHP | 175 | 159 |
| Plotmatic | 135 | 119 |
| Printmatic | 135 | 119 |
| RM/FORTRAN | 595 | 499 |
| SPINDRIFT Library | 149 | 135 |
| TEKMAR Graphics Library | 195 | 169 |
| WATFOR FORTRAN | 375 | 337 |

GRAPHICS LIBRARIES

| | LIST | OURS |
|--------------------------|------|------|
| Essential Graphics | 299 | 229 |
| GraphiC | 395 | 322 |
| Graphics and Animation | 100 | 89 |
| GSS Graphic Dev. Toolkit | 595 | 509 |
| HALO '88 | 325 | 229 |
| HALO '88 for MS Devel. | 595 | 399 |
| PCX Programmer's Toolkit | 125 | 115 |
| PCX F/X | 99 | 90 |
| PCX Text | 99 | 90 |
| Turbo Geometry Library | 150 | 135 |

LIST OURS

| | LIST | OURS |
|-------------------|------|------|
| LINK & LOCATE + + | 395 | 359 |
| OPTLIB | 49 | 45 |
| OPTLINK | 125 | 115 |
| Plink86plus | 495 | 279 |
| PolyLibrarian II | 149 | 131 |
| .RTLink | 195 | 185 |

LINKERS/LIBRARIANS

| | LIST | OURS |
|-------------------|------|------|
| LINK & LOCATE + + | 395 | 359 |
| OPTLIB | 49 | 45 |
| OPTLINK | 125 | 115 |
| Plink86plus | 495 | 279 |
| PolyLibrarian II | 149 | 131 |
| .RTLink | 195 | 185 |

MODULA-2

| | LIST | OURS |
|--------------------|------|------|
| LOGITECH Modula-2: | | |
| Compiler Pack | 99 | 81 |
| Development System | 249 | 199 |
| TopSpeed Modula-2: | | |
| Compiler Kit | 100 | 89 |
| DOS 3-Pack | 180 | 159 |

OBJECT-ORIENTED PROGRAMMING

| | LIST | OURS |
|----------------------|------|------|
| ACTOR | 495 | 423 |
| Language Extension I | 99 | 95 |
| C.talk | 150 | 137 |
| C.talk/Windows | 450 | 399 |
| Smalltalk/V | 100 | 85 |
| Communications | 50 | 45 |
| EGA/VGA Color Ext. | 50 | 45 |
| Goodies #1, #2 or #3 | 50 | 45 |
| Smalltalk/V286 | 200 | 169 |
| Zortech C + + | 150 | 129 |
| w/source | 250 | 209 |

OPERATING SYSTEMS/CONTROL PROGRAMS

| | LIST | OURS |
|------------------------------|------|------|
| Concurrent DOS 386 (3 users) | 395 | 335 |
| 10-User System | 495 | 419 |
| DESQview386 (w/ QEMM) | 190 | 169 |
| QEMM 386 | 60 | 55 |
| MS Windows/386 | 195 | 130 |
| PC-MOS 386 (single user) | 195 | 179 |
| 5 Users | 595 | 539 |
| VM/386 | 245 | 209 |
| VM/386 Multi-user | 895 | 759 |

OS/2 TOOLS

| | LIST | OURS |
|---------------------------|------|------|
| Btrieve for OS/2 | 595 | 455 |
| Epsilon for OS/2 | 195 | 151 |
| Greenleaf DataWindows | 395 | 309 |
| GSS Dev. Toolkit for OS/2 | 695 | 559 |
| KEDIT for OS/2 | 175 | 139 |
| MKS MAKE | 249 | 219 |
| MKS TOOLKIT | 495 | 439 |
| MKS RCS | 395 | 349 |
| MKS VI | 199 | 175 |
| Modula OS/2 | 349 | 279 |
| NeWS/2 | 495 | CALL |
| PCYACC/2 | 395 | 359 |
| PolyAWK for OS/2 | 199 | 159 |
| Vitamin C (OS/2) | 345 | 279 |
| Vermont Views for OS/2 | CALL | CALL |

PASCAL LANGUAGE

| | LIST | OURS |
|-----------------------|------|------|
| B-tree Filer | 125 | 99 |
| DATABOSS | 399 | 359 |
| MS Pascal | 300 | 189 |
| Pascal ASYNCH MANAGER | 175 | 137 |
| POWER SCREEN | 129 | 99 |
| Professional Pascal | 595 | 549 |
| Turbo Analyst | 99 | 79 |

NEW RELEASES

Unbeatable Selection 1-800-445-7899

This Month's Special Offer! FREE!*

With any purchase of software totaling \$100 or more—VEDIT Jr., by CompuView, a powerful, flexible editor ideal for program development and general purpose text editing. It's fast, intuitive and features undos, unlimited keystroke macros, pull-down menus, context sensitive help, automatic indent, unlimited file size and much more!
*(While supplies last)

| | LIST | OURS |
|--------------------------------|------|------|
| TURBO META-MENU | 149 | 139 |
| Turbo Pascal 5.0 | 150 | 112 |
| Turbo Pascal 5.0 Professional | 250 | 187 |
| Turbo Plus | 100 | 89 |
| TurboMAGIC | 199 | 179 |
| Turbo-Plus 5.0 | 100 | 80 |
| PROTOTYPING | | |
| Dan Bricklin's Demo Program II | 195 | 179 |
| Grasp 3.5 | 199 | 169 |
| Instant Replay III | 150 | 131 |
| Proteus | 149 | 125 |
| Show Partner F/X | 350 | 319 |
| REFERENCE GUIDES | | |
| Command Tips | 90 | 80 |
| Norton Guides | 100 | 75 |
| Tom Rettig's HELP | 120 | 105 |
| SORT UTILITIES | | |
| AutoSort | 150 | 131 |
| MS Sort | 195 | 130 |
| Opt-Tech Sort | 149 | 105 |
| Sortex | 150 | 129 |
| TRANSLATORS | | |
| Bas_C (Commercial) | 375 | 323 |
| Bas_Pas (Commercial) | 280 | 242 |
| BASTOC | 495 | 399 |
| dBx TRANSLATOR | 550 | 469 |
| PROMULA.FORTRAN | 450 | 425 |
| TP2C | 249 | 199 |
| UTILITIES | | |
| 1 DIR Plus | 95 | 75 |
| BACK-IT | 129 | 120 |
| Command Plus | 80 | 70 |
| w/Programmer's Toolkit | 130 | 115 |
| Copy II PC | 40 | 35 |
| COPY II PC Option Board | 159 | 139 |
| Disk Technician Advanced | 190 | 159 |
| Disk Technician Plus | 130 | 119 |
| FASTBACK Plus | 189 | 142 |
| HELP ME | 99 | 90 |
| hTest:hFormat | 90 | 80 |
| MACE GOLD | 149 | 129 |
| MACE Utilities | 99 | 90 |
| Magellan | 139 | CALL |
| MKS Toolkit | 199 | 169 |
| Norton Commander | 89 | 56 |
| Norton Utilities | 100 | 61 |
| Norton Utilities, Advanced | 150 | 101 |
| Pathfinder | 70 | 65 |
| PC Fullback | 70 | 59 |
| PC/Tools Deluxe | 80 | 70 |
| V OPT | 50 | 47 |
| Vfeature Deluxe | 120 | 111 |
| Vtools | 50 | 47 |
| XENOCOPY-PC | 80 | 70 |
| XTree | 70 | 60 |
| XTree Pro | 129 | 111 |
| VERSION CONTROL SYS. | | |
| MKS RCS | 189 | 161 |
| PVCS (Corporate) | 395 | 332 |
| PVCS (Personal) | 149 | 131 |
| Seidl Version Manager | 300 | 269 |
| TLIB | 100 | 90 |
| OTHER LANGUAGES | | |
| APL*PLUS PC | 695 | 529 |
| C-terp | 298 | 219 |
| Janus/Ada C Pak | 129 | 115 |
| muLISP-87 Interpreter | 300 | 219 |
| PC Scheme | 95 | 79 |
| PC/FORTH + | 250 | 225 |
| Personal Rexx | 150 | 129 |
| Turbo Prolog | 150 | 112 |
| XENIX/UNIX SOFTWARE | | |
| APL*PLUS | 995 | 699 |
| Aspen Korn Shell | 125 | 109 |
| Basmark QuickBASIC (386) | 695 | 629 |
| db—FILE | CALL | CALL |
| EDIX | 275 | 252 |
| Epsilon | 195 | 152 |
| Informix Products | CALL | CALL |

| | LIST | OURS |
|------------------------------|------|------|
| JAM | 1350 | 1219 |
| JYACC FORMAKER | 895 | 799 |
| Micro Focus COBOL/2 (386) | 3500 | 2995 |
| Microport Sys. V/386 (comp.) | 899 | 759 |
| Microport Sys. V/AT (comp.) | 649 | 549 |
| Microsoft FORTRAN | 695 | CALL |
| Microsoft Pascal | 695 | CALL |
| MKS Trilogy | 119 | 105 |
| PANEL PLUS | 795 | 675 |
| SCO 386 XENIX Sys V (comp.) | 1495 | 1195 |
| SCO MultiView (386) | 495 | 399 |
| SCO XENIX System V (comp.) | 1295 | 999 |

| | LIST | OURS |
|------------|------|------|
| COMPUVIEW | | |
| Vedit Jr. | 29 | CALL |
| Vedit | CALL | CALL |
| Vedit Plus | 185 | 115 |

| | LIST | OURS |
|---------------------------|------|------|
| MICROSOFT | | |
| MS BASIC/6.0 | 295 | 199 |
| MS C | 450 | 299 |
| MS COBOL | 900 | 599 |
| MS Excel | 495 | 299 |
| MS FORTRAN | 450 | 299 |
| MS Mach 20 | 495 | 329 |
| MS Macro Assembler | 150 | 105 |
| MS Mouse, Bus or Serial | | |
| w/Paintbrush, Mouse Menus | 150 | 105 |
| w/EasyCAD | 175 | 129 |
| w/Paintbrush & Windows | 200 | 149 |
| MS OS/2 Prog. Toolkit | 350 | 229 |
| MS Pascal | 300 | 199 |
| MS QuickBASIC 4.5 | 99 | 69 |
| MS QuickC 2.0 | 99 | 69 |
| MS Windows | 99 | 69 |
| MS Windows/386 | 195 | 130 |
| MS Windows Dev. Kit | 500 | 319 |
| MS Word | 450 | 285 |

| | LIST | OURS |
|-----------------------------|------|------|
| MORTICE KERN SYSTEMS | | |
| MKS AWK | 99 | 89 |
| MKS LEX:YACC | 249 | 219 |
| MKS MAKE | 149 | 135 |
| MKS RCS | 189 | 169 |
| MKS SQPS | 495 | 479 |
| MKS Toolkit | 199 | 179 |
| MKS Trilogy | 119 | 105 |
| MKS VI | 149 | 135 |

| | LIST | OURS |
|-------------------------|------|------|
| PERISCOPE | | |
| Periscope I/512K | 795 | 675 |
| Periscope I/OK | 545 | 489 |
| Periscope II | 175 | 155 |
| Periscope IIx | 145 | 129 |
| Periscope III | 1395 | 1255 |
| Periscope III PLUS/512K | 1995 | 1795 |
| Periscope III PLUS/OK | 1745 | 1569 |
| Periscope IV | CALL | CALL |

| | LIST | OURS |
|--|------|------|
| SOUTH MOUNTAIN (ESSENTIAL SOFTWARE) | | |
| Breakout II | 125 | 99 |
| C Utility Library | 199 | 169 |
| Essential B-Tree | 99 | 89 |
| w/source | 198 | 169 |
| Essential Communications | 185 | 149 |
| Essential Graphics | 299 | 249 |
| w/source code | 598 | 539 |
| /*resident C*/ | 99 | 89 |
| w/source code | 198 | 169 |
| Screen Star | 99 | 89 |
| w/source code | 198 | 169 |

PROGRAMMER'S POLICIES

Phone Orders
Hours 9 AM-7 PM EST. We accept MasterCard, Visa, American Express. Include \$4.00 per item for shipping and handling. All shipments by UPS ground. Rush service available.

Mail Orders
POs by mail or fax are welcome. Please include phone number.

International Service
Phone number required with order. Call or fax for additional information.

Dealers and Corporate Accounts
Call for information.

Unbeatable Prices
We'll match nationally advertised prices. (Subject to same terms and conditions.)

Return Policy
30-day no-hassle return policy. Some manufacturer's products cannot be returned once disk seals are broken.

VERMONT VIEWS

Create the human interface of your dreams. Vermont Views offers an unparalleled set of C interface building blocks that you can combine in unlimited ways.

Create menus in any style you choose, scrollable vertically and horizontally, and nested to any level. Data entry forms can be bigger than their display windows and have scrollable regions. A mini word processor can be attached to a field window in a form or used as a pop-up note taker. And Vermont Views' modular construction and thorough documentation make it easy to learn and use. List: \$395 Ours: CALL



Vermont Creative Software

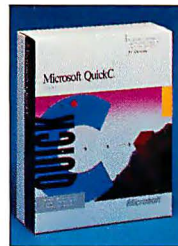

Microsoft®

MICROSOFT QuickC 2.0

Microsoft QuickC Compiler 2.0 offers both technology enhancements to help programmers master C quickly and easily, and tremendous productivity benefits for the C programmer who prefers an integrated environment. Version 2.0 contains an online reference system, Microsoft QuickC Advisor, which uses hypertext technology to place a wealth of information and example C code at your fingertips. QuickC 2.0 now features incremental compilation and linking which dramatically improves compilation speed, and a built-in, in-line assembler. You can edit, compile/assemble and debug C and in-line assembly code without leaving the environment. List: \$99 Ours: \$69

NEW PERISCOPE IV HARDWARE-ASSISTED DEBUGGER

Periscope Model IV is the powerful new hardware-assisted debugger for 286 and 386 PCs running up to 25MHz with 0 wait states. Its specialty is helping you find the bugs that software debuggers can't find. It will show you exactly what's going on in your system; save you days of debugging time; help you optimize your code; give you real-time debugging on a wide range of machines; help you make your software more robust; and much more. With it you get the full-function, easy-to-use Periscope software. List: CALL Ours: CALL

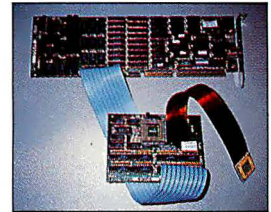

PERISCOPE

VEDIT PLUS 3.0



New VEDIT PLUS 3.0 is the ideal programmer's editor with stunning performance, speed and versatility. New features include 1000 level undo, columnar blocks, true regular expressions, an easy to use pull-down menu system and context sensitive help. You also get multiple file editing (any file size), windows, total configurability and the most powerful macro programming language available. The new automatic compiler support is highly flexible and comes ready to use for Microsoft, Borland and many other compilers and assemblers. List: \$185 Ours: \$115

CompuView

In NY: 914-332-4548
Customer Service: 914-332-0869
International Orders: 914-332-4548
Telex: 510-601-7602

Fax: 914-332-4021
Call or Write for Latest Free Catalog!

1-800-445-7899

Programmer's Paradise

A Division of Voyager Software Corp
55 South Broadway, Tarrytown, NY 10591

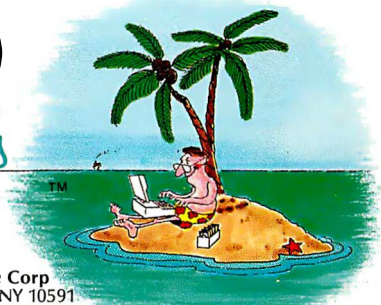

NOW YOUR SOFTWARE CAN TEST ITSELF.

Your customers expect software that works. All the time. The key to software quality is exhaustive testing. It's also an engineer's worst nightmare. But it doesn't have to be. Because now you can automate your software testing.

Introducing the Atron Evaluator. The first and only non-intrusive automated PC-based software testing tool.

The Atron Evaluator automatically runs your software regression testing programs. All of them. All day. All night. Giving you thoroughly tested, higher quality software.

The Atron Evaluator is hardware-based. And since it's non-intrusive, software behavior is tested without the risk of alteration. Once your tests have run, you can refer to automatically generated test reports to double-check test results.

The Atron Evaluator saves time. And time makes you money. Development cycles are shortened, so your software gets to market sooner. And while your test programs are running, you can be more productive. Start a new project. Or go home.

For more information about the Atron Evaluator, call us at **1-800-283-5933**. And put an end to your worst nightmares. Automatically.



A Division of CADRE Technologies

Saratoga Office Center
12950 Saratoga Avenue
Saratoga, California 95070

Circle 28 on Reader Service Card

In Europe, contact:

Elverex Limited, Enterprise House
Plassey Technology Park, Limerick, Ireland
Phone: 061-338177

QA Training Limited, Cecily Hill Castle
Cirencester, Gloucestershire, GL7 2EF, England
Phone: (0285) 5888

WHAT'S NEW

HARDWARE • SYSTEMS

HP System Supports X Windows

The Hewlett-Packard 9000 Model 340SRX workstation offers three-dimensional graphics with 4-MIPS performance on an HP-UX (HP's version of Unix V) operating system. The 340SRX also supports X Windows.

The brains of the 340SRX are Motorola's 68030 microprocessor coupled with the 68882 FPU, both running at 16.7 MHz. It has 4 megabytes of memory (expandable to 16 megabytes).

Besides X Windows, communications involves a built-in RS-232C port and two general-purpose interface bus (GPIB) ports, and you choose either an AUI LAN interface (for thick coaxial cabling) or a ThinLAN interface (for thin coaxial cabling). Supported protocols include ARPA Berkeley, TCP/IP, Ethernet IEEE 802.3, and NFS.

Optional interfaces are available for HP-IB and SCSI.

The system has a 16-inch color monitor with 1280- by 1024-pixel resolution. There are eight three-dimensional frame-buffer planes (upgradable to 24) and 256 display colors (upgradable to 16.7 million). The system also includes the Starbase Graphics Library.

Price: \$14,900.

Contact: Hewlett-Packard, 19310 Pruneridge Ave., Cupertino, CA 95014, (800) 752-0900.

Inquiry 1123.



The HP 9000 Model 340SRX does three-dimensional graphics, X Windows, and LANs.

Dolch Ships 25-MHz 80386 Portable

At the heart of the new Dolch portable is a 25-MHz, zero-wait-state microprocessor that Dolch Computer Systems claims is 32 percent faster than the Compaq Portable 386.

The Dolch-P.A.C. (for portable add-in computer) measures 16 by 10 by 8 inches and weighs 20 pounds.

The key to system speed, Dolch says, is a proprietary 64K-byte disk-cache buffer-management system.

The standard configuration includes a CGA display (EGA optional), an 86-key keyboard that's detachable so you can replace it with your own keyboard, three open slots (two full-length 16-bit and one half-length 8-bit), 4 megabytes of RAM, a 1.2-megabyte 5 1/4-inch floppy disk

drive, and a SCSI port.

Price: \$9495.

Contact: Dolch Computer Systems, 2029 O'Toole Ave., San Jose, CA 95131, (408) 435-1881.

Inquiry 1125.

You Need This "Virus-Proof" PC

The Immune System, a DOS-based 80286 computer, is designed for security by one of the largest computer security companies in the nation.

Along with some things you'd expect on a standard clone, such as 1 megabyte of RAM, a 1.2-megabyte 5 1/4-inch floppy disk drive, and a 40-megabyte hard disk drive, there's a "virus-proof" feature that keeps unauthorized .EXE and .COM files from entering or running on the system.

SEND US YOUR NEW PRODUCT RELEASE

We'd like to consider your product for publication. Send us full information, including its price, ship date, and an address and telephone number where readers can get further information. Send to New Products Editor, BYTE, One Phoenix Mill Lane, Peterborough, NH 03458. Information contained in these items is based on manufacturers' written statements and/or telephone interviews with BYTE reporters. BYTE has not formally reviewed each product mentioned. These items, along with additional new product announcements, are posted regularly on BIX in the microbytes.sw and microbytes.hw conferences.

There's also a modem package that purports to secure and encrypt real-time conversations, as well as provide a system-use audit trail, a system-access audit trail, and nearly 25 more security features. American Computer Security Industries has even gone so far as to secure the clock so only specified users can set or change the time.

Price: \$2995.

Contact: American Computer Security Industries, 122 Blue Hills Court, Nashville, TN 37214, (615) 883-6741.

Inquiry 1126.

Personal Mainframe for Your AT

How much number-crunching is enough? Opus Systems thinks there's plenty of room for improvement over a standard AT clone; in fact, the company would like to lift the lid of your machine and drop a new computer inside.

The Personal Mainframe Series 400 consists of a coprocessor board that contains a Motorola 88000 RISC CPU and 4 megabytes of RAM—enough to run Unix, which also comes with the system.

Opus is offering the Series 8000, which consists of a Series 400 coprocessor inside an Everex Step/286. The resulting systems are rated at 35,000 Dhrystones and 17 MIPS, according to Opus. **Price:** Series 400, \$5000; Series 8000, \$9995.

Contact: Opus Systems, 20863 Stevens Creek Blvd., Bldg. 400, Cupertino, CA 95014, (408) 446-2110, or Everex Systems, 48431 Milmont Dr., Fremont, CA 94538, (415) 498-1111.

Inquiry 1124.

continued

IBM Laser Printer Speaks AppleTalk

Big Blue has acknowledged Apple Computer's dominance of the desktop publishing business with the addition of an AppleTalk port to its PagePrinter laser printer.

In fact, the new IBM PagePrinter II supports Adobe Postscript, HP LaserJet, and IBM ProPrinter emulation and has parallel, serial, and AppleTalk connectors, making it suitable for use with any personal computer system.

The 300-dpi PagePrinter II prints at 6 pages per minute. Inside, it has an on-board 16-MHz 68000 processor and 2 megabytes of RAM, expandable to 4 megabytes. Its predecessor, the PagePrinter, featured a 10-MHz 68000 processor on an add-on board, which used an expansion slot in the host PC and limited its use to IBM PC-compatible computers.

The original PagePrinter had only 13 fonts in ROM. The new PagePrinter II has 43 Adobe PostScript fonts built into ROM and can support an additional 60 fonts with the 2-megabyte memory expansion.

Price: \$4999.

Contact: IBM, DRM, Dept. 122, 101 Paragon Dr., Montvale, NJ 07645. For a dealer near you, call (800) 426-7257, ext. 122.

Inquiry 1128.

Exploit Your NeXT's DSP for CD-Quality Sound

Get a jump on digital-signal-processing (DSP) microchip technology with the Digital Ears-I from Metaresearch. This peripheral allows you and your NeXT computer to enter and record



PagePrinter II supports most PCs and Macintoshes.

high-quality sounds on compact disk. You can then incorporate them into programs, reports, and applications.

It takes audio-line-level signals (in stereo or mono) and converts them to CD-format digital information for processing by your NeXT computer's DSP. With two channels of stereo line input into two channels of 16-bit, 44.1-kHz digital information, you and your NeXT computer can create sound files with a signal-to-noise ratio of 90 decibels and a channel cross-talk rating (in stereo mode) of -85 dB at 10 kHz.

The package includes sample recordings and software that allows you to create sound files in the standard NeXT format. Total harmonic distortion is rated at -90 dB, A/D input voltage is rated at ± 5 volts, and input impedance is 100,000 ohms.

You might consider making a low-cost digital recording studio, developing voice and speech analysis software, or using the peripheral as a high-frequency, high-resolution laboratory voltage-measurement device.

Price: \$825.

Contact: Metaresearch, Inc., 516 Southeast Morrison, Suite M-1, Portland, OR 97214, (503) 238-5728.

Inquiry 1129.

Replace Your Keyboard Inexpensively

Membrane-switching technology is approaching capacitance-switching technology in keyboards for IBM PCs, according to Key Tronic Corp.

The Professional Series MB 101 is rated at 30 million life cycles per key switching.

Price: \$89.
Contact: Key Tronic Corp., P.O. Box 14687, Spokane, WA 99214, (800) 262-6006; in Washington, (509) 927-5515.
Inquiry 1130.

Erasable, Optical Media Greets Your Mac

For your reading, writing, and erasing whims, the Jasmine DirectOptical disk drive features removable 5 1/4-inch cartridges with 297.6 megabytes of formatted storage capacity per side.

The drives are based on a Ricoh mechanism, with average seek times rated at 50 ms. Data transfer at the SCSI port is 1.2 megabytes per second.

Price: \$4995.
Contact: Jasmine Technologies, Inc., 1740 Army St., San Francisco, CA 94124, (800) 347-3228; in California, (415) 282-1111.
Inquiry 1131.

Scanner Matches Typesetting Resolution

The Hewlett Packard 9195A Image/OCR Desktop Scanner is an 8-bit, 256-level gray-scale scanner.

Add some software from third-party developers, and Macintosh users can scan documents and manipulate the scanned images the way a photographer "custom prints" a photograph, Hewlett Packard claims. While PC users don't have the Macintosh's graphics capabilities, they can use it for automatic scaling and optical character recognition.

Whatever the computer, you can use either laser printers with resolutions of 300 dpi by 300 dpi, or typesetters. The 8-bit scanner matches output resolution from 12 dpi to 1500 dpi in one-dot increments.

DeskScan software for your PC allows you to use the ScanJet Plus as a simple copy machine with a default resolution of 216 dpi.

Interactive scaling displays the effects of size adjustments to the image on your computer screen. Scanned files are stored and brought to PC application software through file formats including TIFF, Microsoft Paint, GEM, PC Paintbrush, and EPSF. Mac users can run HP's Desk Gallery Plus software with image files stored in TIFF, EPSF, MacPaint, PICT, and the Clipboard.

Price: \$1595; interfaces for PCs, Macs, and PS/2s, \$595 each; document feeder, \$595; OCR software, \$595.
Contact: Hewlett-Packard Co., 19310 Pruneridge Ave., Cupertino, CA 95014, (800) 752-0900.
Inquiry 1132.

continued

After centuries of practice, mankind perfects engineering calculations: MathCAD.

Announcing MathCAD: A Calculating Renaissance For Your Mac.

What the historians will call it, only time will tell.

Perhaps the Century of Speed, or the Era of Ease. But whatever the name, this is the age of MathCAD, the only math package that looks and works the way you think.

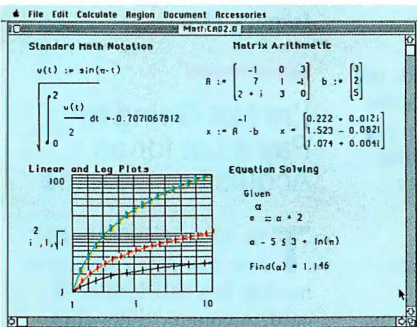

MathCAD takes full advantage of the Macintosh® interface, with features that make it simple to enter operators and Greek letters into equations.

MathCAD is the best selling math software in the world because it lets you perform engineering and scientific calculations in a way that's faster, more natural and less error-prone than the way you're doing them now—whether you're using a scratchpad, calculator, spreadsheet, or program that you wrote yourself. It gives you more control and more flexibility than ever before.

MathCAD's live document interface™ lets you enter equations anywhere on the screen, add text, and graph the results. Then print your analysis as a presentation quality document.

And it has over 120 commonly

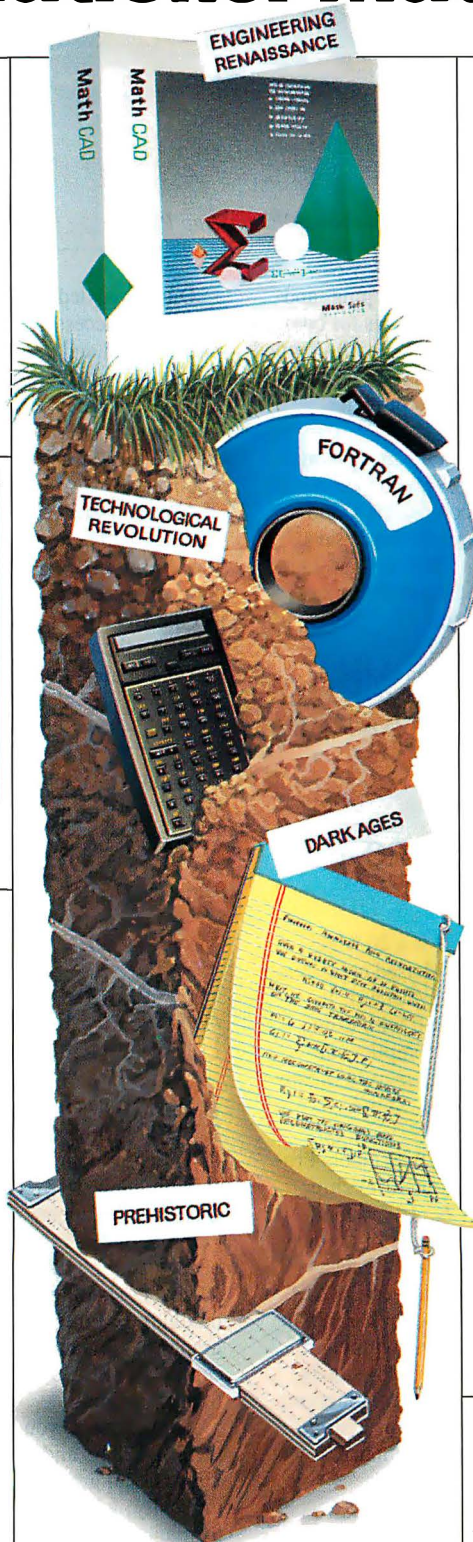

used functions built right in, for handling all kinds of equations and formulas, as well as exponentials, differentials, cubic splines, FFTs and matrices.

No matter what kind of work you do, MathCAD has a solution for you. In fact, it's used by over 50,000 engineers and scientists, including electrical, industrial, and mechanical engineers, physicists, biologists, and economists.

But don't take our word for it. Just recently MathCAD was reviewed as being "everything you have ever dreamed about in a mathematical toolbox." And when it was compared to the competition, it was "MathCAD by a mile."

And if you work with an IBM® PC or compatible, there's a MathCAD version designed exclusively for you. Or if you use both Macs and PCs, don't worry: MathCAD files are completely compatible between the two.

Look for MathCAD at your local software dealer. Or call MathSoft at 1-800-MATHCAD (in MA, 617-577-1017) for more information or for a free demo disk.

Speed, power and flexibility. Enter the new era of engineering and scientific calculations, with MathCAD.

System Requirements: Apple Macintosh Plus, SE or II, with a minimum of 1MB RAM. Supports all Image Writers® and Laser Writers®.

MathCAD®

MathSoft, Inc. One Kendall Square, Cambridge, MA 02139

Accelerate Those Model 50s and 60s

The Hummingbird 50/60 is a 20-MHz 80286-based add-in board that boosts the performance of your IBM PS/2 Models 50, 50 Z, and 60 up to that of the 80386-based 20-MHz Models 70 and 80. It also includes 3270-emulator software.

To install it, you use a special "chip-puller" tool to remove the 80286 from the original motherboard. You plug the adapter module into the Hummingbird adapter card, which you plug into the Micro Channel slot.

Once your installation is complete, you've got a zero-wait-state, 20-MHz, CMOS 80286 chip and 32K bytes of 55-ns static RAM. The cache is updated during direct-memory-access reads, and there's a programmable cache for adapter ROMs.

Manufacturer Polywell claims the new system operates exactly as before—with the same support for the 80287 chip, for example.

For software that is dependent on the slower clock speed, the HiSpeed program is available to temporarily disable the cache. The 3270 emulation works at all speeds.

Price: \$995.

Contact: Polywell, Inc., 61C Airport Blvd., South San Francisco, CA 94080, (415) 583-7222.

Inquiry 1133.

Scion Captures No-Wait Redraw

The Scion Image Capture Board for the PC and the Image Capture Board II for the Mac II both digitize and display images at 30 frames per second. There's no wait for redraw.

Both 8-bit cards allow 24-

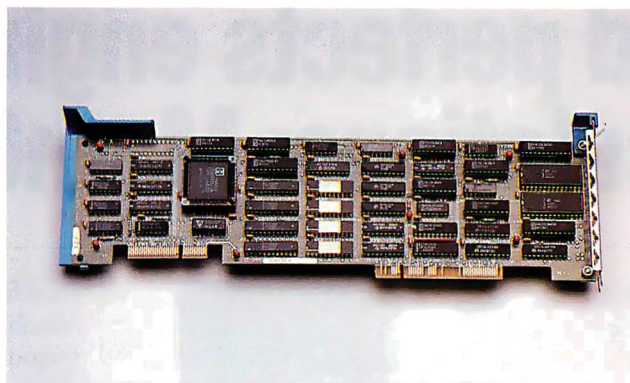

Polywell's Hummingbird 50/60 revs up PS/2s.

bit capturing, cropping, and centering of images for color display. Images are bit-mapped into 256 levels of gray, and both cards can provide halftones.

Input can be any National Television System Committee (NTSC) compatible video source, and the cards save images in TIFF format. Output resolution is 640 pixels by 480 pixels.

Price: \$1195.

Contact: Scion Corp., 3 North Main St., Walkersville, MD 21793, (301) 845-4045.

Inquiry 1135.

Give Your PC a SPARC

The SP-1 is a 20-MHz SPARC-based coprocessor system on an AT card. It comes bundled with C and FORTRAN compilers derived from those used in Sun Microsystems' Sun-4 workstations.

The SPARC (Scalable Processor Architecture) chip, model CY7C601, is combined with Texas Instruments' T18847 FPU and 8 megabytes of interleaved DRAM. Each SPARC chip has 136 32-bit registers, with eight overlapping windows of 24 registers each. Manufacturer Definicon Systems claims 12-MIPS performance.

Once installed, the coprocessor can access graphics cards, serial and parallel ports, A/D converters, disk drives, and other peripherals by using the 80286 or 80386 host CPU as an I/O controller.

The included software translates DOS commands into the Unix-type format that the Sun compilers expect. So you get the DOS you're familiar with and the functionality of working in a Sun environment.

Price: \$5495; with 8 megabytes, \$7495.

Contact: Definicon Systems, Inc., 1100 Business Center Cir., Newbury Park, CA 91320, (805) 499-0652.

Inquiry 1136.

Surface Mount Allows Field Upgrading

Matrox has introduced three dimensions to its AT graphics controller cards.

With the new PG-1281C, you get two-dimensional graphics and upgrade capabilities through the SM-1281C/F (shading-engine module) for three-dimensional graphics. This upgrade process takes only 30 minutes, Matrox claims.

Alternatively, you can buy the SM-1281C and have three-dimensional graphics automatically, with the same performance as with the two-dimensional and three-

dimensional shading-engine module.

The PG-1281C gives you 125,000 vectors per second and 30,000 cps and can be upgraded with the SM-1281C/F for 80,000 three-dimensional vectors per second. Matrox claims that you can then generate up to 20,000 Gouraud-shaded polygons per second for fast rendering of shaded images.

Price: PG-1281C, \$4995; SM-1281C/F, \$3995; SM-1281C, \$8495.

Contact: Matrox Electronics Systems, Ltd., 1055 St-Regis Blvd., Dorval, Quebec, Canada H9P 2T4, (514) 685-2630.

Inquiry 1137.

I'm Not Going to Pay a Lot for an Acquisition Module

The ADAC 5500MF is a low-cost data acquisition module in a half-length AT card. A counter/timer chip provides it with three programmable timers, which allow the 5500MF to be used in pulse-generation, timing, and counting applications.

The 5500MF will accept as many as eight analog inputs multiplexed to a 12-bit A/D converter. Hardware conversion time is 40 μ s, and 25-kHz throughputs can be achieved. Each module has 16 lines of TTL-level I/O.

LabTech Acquire software allows you to perform data acquisition on four of the eight analog inputs and one digital input. Up to 50 samples per second can be manipulated.

Price: \$295.

Contact: ADAC Corp., 70 Tower Office Park, Woburn, MA 01801, (800) 648-6589; in Massachusetts, (617) 935-6668.

Inquiry 1138.

continued

Pull out all the stops

Turbo C® Professional is the *only* production-quality C compiler with a completely integrated environment.

Everything you need—all the tools—are *included* in this environment, so you never waste time stopping, starting, and switching between tools.

And you're not forced into trade-offs between high-productivity programming and small, fast, reliable code. Instead you get the fastest and the best of both worlds.

There's tight integration between editor, compiler, linker, and debugger that lets you race through your program with a fast edit/compile/run/debug cycle.

Only Turbo C Professional gets it all together

Now everything you need to write and debug production-quality, optimized code in *both* C and

Assembly language is all yours in one package.

With Turbo C Professional you get:

- Turbo C 2.0 with its own integrated development environment—Compiler, Editor, Debugger, and Linker.
- Plus a separate command-line C Compiler
- Turbo Assembler®—a complete Macro Assembler that's more compatible with MASM than MASM is with itself.
- And the new source-level Turbo Debugger® that lets you debug *any size program*. Turbo C Professional has it all.

Turbo C 2.0

- Compiles over 16,000 lines per minute
- Hypertext online Help
- Supports inline assembly
- All six memory models supported
- More than 450 library functions

Turbo Assembler

- Assembles up to 48,000 lines per minute
- Compatible with MASM 4.0, 5.0, 5.1
- Full 386 support
- Assembles multiple files

Turbo Debugger

- Debug any size program
- Browse through structures with data debugging
- Set conditional breakpoints, break on memory access
- Stop, run code, log expressions
- 386 ICE capabilities

Turbo C, Turbo Pascal, Turbo Assembler, and Turbo Debugger are registered trademarks of Borland International. Copyright © 1989, Borland International, Inc. All rights reserved. BI 1286

Code: MC05

Turbo Debugger is a winner

Turbo Debugger won *PC Magazine's* most recent Award for Technical Excellence, and here's what they said:

"Everyone who's tried the Turbo Debugger agrees. It wins the (development tool) category's award for Technical Excellence hands down. The user interface is simple yet elegant; the program works the way programmers want to work. Yet again, Borland has advanced the state of the art in an eminently useful way."

Bill Machrone, Editor-in-Chief, *PC Magazine*

Debug any size program

Turbo Debugger lets you debug on a remote machine. That's a win. And in virtual mode of the 386, it allows you to debug *any size program*. Even your largest—*especially* your largest. That's a huge win.

And it can give you 12 *different* views of your code. It supports browse-through data debugging; offers flexible breakpoints; supports in-circuit emulation; offers EMS support; has a "Point & Shoot" integrated debugging environment, and is completely CodeView® compatible. Turbo C Professional does all that, so *it* wins—and so do *you*.

Pull out all the stops

Turbo C's integrated environment lets you completely stop stopping. Your program is never interrupted. No stops and no gaps. You compile faster. Link faster. Work faster. Think faster. So turn to Turbo C Professional: There's nothing stopping you now.

This is no ordinary Demo

Not one, not two, but three different demos on the same disk: Turbo C, Turbo Pascal,® and Turbo Debugger. We'll send you the demo disk and fact sheets with technical information for \$4.95. **To order, CALL (800) 345-2888 Ext. 200**



B O R L A N D

POWER TION

...d the field had been ranked and the odds
...sonal computer spreadsheet software. a

New program ...es to fend off Spreadsheet war

...NGE, Mass. — Lo-
...red to fight the
...ar with sweep-
...its reseller pro-

• A restructuring
...MIF plan. The qual-
...ining comen-
...phanz

Spreadsheet Ready to Pounce

January 28, 1989

Analysts said that
... 1-2-3 will b

...t Gain
...on Riv
...creating a spreadsheet

The Spreadsheet Important Update.

to be precise. Linking either in memory or on disk, either pages of the same spreadsheet or independent, either SuperCalc5's files or Lotus® 1-2-3®'s.

and compatible computers but also takes full advantage of 286 and 386 machines when you decide to make that transition.

And if all that isn't enough to make you run out today and join the revolution, there's even more incentive.

Like our free demo disk offer through July 31, 1989. And our \$100 upgrade offer for just about any spreadsheet you're using. Call 1-800-531-5236. In Canada call 1-800-663-6904.

Which finally brings us to our admittedly biased outlook for the much touted spreadsheet war. With SuperCalc5, peace is at hand.

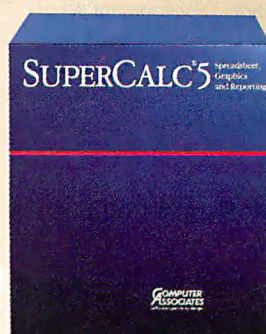

Andy's Bunnies
Income Statement
FY Ending January 31, 1991
Unaudited

| | This Year | Last Year |
|---|-------------|-------------|
| Revenue: | | |
| Sales | \$5,778,453 | \$4,009,872 |
| License | \$1,444,775 | \$477,313 |
| Sales Discounts | (243,999) | (497,248) |
| Rentals-Related Fees | \$67,991 | \$124,507 |
| | \$7,462,220 | \$4,104,442 |
| Cost of Sales: | | |
| Opening Inventory | \$9,642,251 | \$5,476,212 |
| Purchases | \$139,814 | \$4,229,264 |
| Freight In | \$5,722 | \$4,342 |
| | \$9,827,787 | \$9,740,118 |
| Ending Inventory | \$7,234,110 | \$9,659,241 |
| Cost of merchandise | \$2,493,256 | \$1,080,877 |
| Direct labor | \$1,447,951 | \$1,477,243 |
| Employee benefits | \$289,390 | \$335,449 |
| Rentals supplies | \$279,444 | \$310,442 |
| Total Cost of Sales | \$4,911,257 | \$2,919,861 |
| Gross Profit | \$2,550,963 | \$1,772,317 |
| Less selling, general and admin expenses | \$469,867 | \$195,771 |
| Earnings (Loss) from operations | \$2,081,096 | \$1,211,243 |
| Other income and expense: | | |
| Interest income | \$11,309 | \$9,765 |
| Other income | \$17,899 | \$15,666 |
| Gain (Loss) on sale of fixed assets | (327) | 85 |
| | \$28,829 | \$25,431 |
| Provision for income taxes: | | |
| Current income taxes | \$1,043,287 | \$405,771 |
| Deferred income taxes | \$0 | \$0 |
| | \$1,043,287 | \$405,771 |
| Net earnings (loss) for period | \$1,043,287 | \$600,222 |

Produce annual-report quality output everyday.

Letting you easily move 1-2-3 macros into SuperCalc5 and back again. Even toggling between menus is a snap for SuperCalc5.

But not for Excel®.

Which now brings us to the "E" word. Unlike Excel, SuperCalc5 runs on all IBM®

Microsoft. IBM is a registered trademark of International Business Machines.

Circle 61 on Reader Service Card

COMPUTER ASSOCIATES
Software superior by design.

Measurement Control at Its Finest

The Universal Data Manager is a general-purpose data-acquisition and -control system that's run with your 80286 or 80386 machine. It communicates through RS-232C or IEEE-488 channels.

The measurement and control configuration of the UDM can be any combination of analog and digital I/O functions. In the IEEE-488 bus configuration, up to 15 units can be connected to each computer, with multiple communications channels. Signal extenders allow you to locate the UDM some distance from the computer.

Standard equipment on the UDM includes several support libraries (e.g., BIOS, IEEE-488, and RS-232C) and high-level Data Manager commands.

You can manipulate I/O so that it will acquire data automatically at high speed until the system's internal data buffers are filled. Then the computer can perform data reduction and analysis. Data can also be acquired or sent until a particular pattern occurs.

Price: \$860.

Contact: Development Associates, 1520 South Lyon St., Santa Ana, CA 92705, (714) 835-9512.

Inquiry 1152.

Gray-Scale LCD Projector for PCs Includes Memory

The PC Viewer is an LCD peripheral for an overhead projector. It comes with 1 megabyte of static RAM for storing computer-generated presentation frames. It works with IBM PCs and compatibles that have CGA, EGA, and VGA graphics capabilities, as



The UDM controls RS-232C and IEEE-488 I/O.

well as with the Apple II and Macintosh computers.

With it, you don't need the computer when you make your presentation—all you need is the 12- by 12- by 2-inch PC Viewer and an overhead projector. You simply plug the PC Viewer into your computer, bring up the screen you want to store, and select the screen-capture option using the projector's remote controller. Once you've stored the images, you can leave the computer behind.

PC Viewer is so small because it's made of a heat-resistant LCD material. It comes with an electronic pointer and an infrared hand-held remote controller that can be used to edit the timing and sequence of the stored display frames. Up to 100 frames can be stored in the 1-megabyte memory space.

Price: Gray-scale, \$2995; blue/yellow display, \$2695.

Contact: In Focus Systems, Inc., 7649 Southwest Mohawk St., Tualatin, OR 97062, (503) 692-4968.

Inquiry 1153.

Plot Faster with Your LaserJet

Plotter in a Cartridge is a complete emulation of Hewlett-Packard's 7475A plotter, and it implements the Hewlett-Packard Graphics Language (HPGL) on an HP LaserJet Series II printer.

Pacific Data claims that Plotter in a Cartridge will plot complex layouts, like circuit boards, more than 10 times as fast as PC-based HPGL plotters.

Plotter in a Cartridge plugs into the font cartridge slot of the printer and is compatible with all the major CAD, presentation graphics,

and spreadsheet graphics software. Features include variable pan/line thicknesses, x- and y-axis scaling, arc and circle generation, plot rotation, multiple fill and shading patterns, and paper-sizing capabilities.

Price: \$395.

Contact: Pacific Data Products, 6404 Nancy Ridge Dr., San Diego, CA 92121, (619) 552-0880.

Inquiry 1154.

Server Provides Network Access to CD-ROM Drives

The Network-OS CD Server allows multiuser access of up to 14 CD-ROM drives through Novell and CBIS network operating systems.

You can also use it to share printers, disk drives, files, and other resources. It is hardware-independent as long as your networking hardware is NetBIOS-compatible.

The standard Network-OS CD Server system includes one drive in the tower-size file server, which can read any 600-megabyte CD-ROM information in ISO 9660/High Sierra format. It comes with a display, a keyboard, and a 5¼-inch floppy disk drive, and it has a SCSI port.

Its brain is a one-wait-state 12-MHz 80286 CPU with 640K bytes of RAM (upgradable to 16K bytes).

The standard system allows installation of up to seven drives; an optional expansion chassis can have an additional seven drives.

Price: \$5250; Network-OS software, \$160 per node.

Contact: CBIS, Inc., 5875 Peachtree Industrial Blvd., Bldg. 100/170, Norcross, GA 30092, (404) 446-1332.

Inquiry 1155.

continued



And then...
Maxell created
the RD Series.

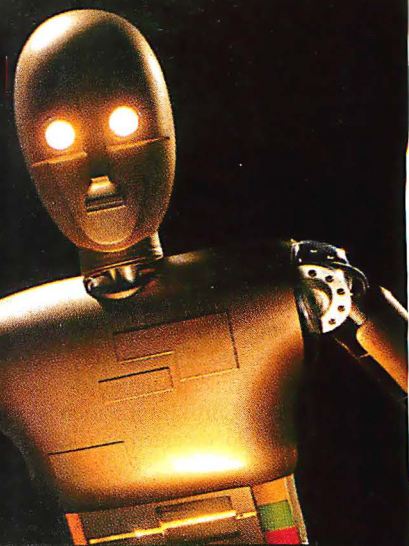

The
Evolution
of the
Floppy Disk

Maxell Corporation of America, 22-08 Route 2008, Fair Lawn, NJ 07410

Never before has this level of Reliability and Durability been available in floppy disks. Introducing the new RD Series from Maxell. Twice the durability of the disks you're now using. Twice the resistance to dust and dirt. And the RD Series is ten times more reliable than conventional floppy disks. The Gold Standard has always meant maximum safety for your data. Now it means even more.



maxell[®]
THE GOLD STANDARD

ADIC Guarantees File Server Backup

The LANbacker 8000 guarantees data backup from your IBM PC or compatible NetWare file server, claims Advanced Digital Information Corp. Information is filed and documented by file or session backup date.

Auto Execution Monitor software lets you set up everything in advance, and you can daisy chain up to seven of the dot-matrix-printer-size units. Then you can sit back and let the software and 3M-designed DC-2000 data cartridges do their thing.

Price: With 60-megabyte cartridges, \$5995; with 120-megabyte cartridges, \$7995.

Contact: Advanced Digital Information Corp., 14737 Northeast 87th St., P.O. Box 2996, Redmond, WA 98073, (800) 336-1233; in Washington, (206) 881-8004.

Inquiry 1142.

Turn Your XT into an X Windows Workstation

P-C-Xview is a communications package from Graphic Software Systems. It works in XT compatibles that are already connected on an Ethernet.

Version 1.0 works only with the Exelan 205T Ethernet cards. Version 1.1 will work with any FTP drivers currently written for cards from 3Com, InterLAN (formerly Micom-InterLAN), Western Digital, and others. Version 1.1 will also support LIM/EMS 4.0.

Price: \$295; version 1.1, \$320.

Contact: Graphic Software Systems, Inc., 9590 Southwest Gemini Dr., Beaverton, OR 97005, (503) 641-2200.

Inquiry 1144.



Data cartridge backup on the LANbacker 8000.

IGOR Uploads, IGOR Downloads

With accompanying file transfer software, IGOR can be preset to initiate and perform as many as three host sessions and as many as 12 file transfers between your PC and your host. That includes support for 3270 emulators.

IGOR comes either bundled with a 3270 card or unbundled. It requires about 85K bytes of RAM on your IBM PC or compatible. LAN support is planned.

Price: \$150 for software alone; software and card, \$650.

Contact: Lazarus Data Products, 815 Manhattan Ave., Manhattan Beach, CA 90266, (213) 318-6290.

Inquiry 1151.

Banyan Ships Vines 3.1

Banyan recently enhanced its network operating system, Vines, to support additional add-in cards and a new developer's toolkit.

Vines 3.1 now supports

IBM's 16-mbps Token Ring interface cards, 3Com's 3C603 cards, DOS 4.0 for Vines clients, and Compaq's internal 135-megabyte tape drives for 80386-based systems.

An optional toolkit contains a standard Unix System V development environment and a mail gateway to support the integration of Banyan Mail with other vendors' mail systems.

Price: Vines 3.1, \$4995; toolkit, \$1995.

Contact: Banyan Systems, Inc., 115 Flanders Rd., Westboro, MA 01581, (508) 898-1000.

Inquiry 1143.

AppleTalk File Server

The DirectServe system acts as a file server for up to 20 Macintoshes on an AppleTalk network, something that was previously available only by using at least a Mac Plus or by dedicating a personal computer.

One of the main advantages, Jasmine claims, is speed. With memory-caching techniques, Jasmine estimates a 20 percent to 40 percent increase over using a Mac as the server. And you're still assured of compatibility with the AppleTalk Filing Protocol.

Each DirectServe is driven

by a 10-MHz zero-wait-state 68010 microprocessor. The standard motherboard comes with 1 megabyte of RAM and can accommodate up to 32 users. Memory can be expanded to 2 or 4 megabytes.

You'll still need a hard disk drive with a capacity of up to 300 megabytes, depending on your applications.

Price: \$1299.

Contact: Jasmine Technologies, Inc., 1740 Army St., San Francisco, CA 94124, (800) 347-3228; in California, (415) 282-1111.

Inquiry 1141.

Server Supports 15 Simultaneous Dial-Up Sessions

Novell is using Quarterdeck's multitasking, multiwindowing DESQview software in a product that will provide improved remote-access capabilities. It's called the NetWare Access Server.

To use it, you'll need DESQview, the NetWare Driver, and Novell wide-area-network interface module (WNIM Plus) boards on an 80386-based machine. You and 15 colleagues on the road or in remote offices can have dial-up access to the Novell LAN resources in the main office through a single dedicated file server.

Each of the WNIM Plus boards supports four simultaneous sessions. Since DESQview supports 15 sessions, you'll need four boards for maximum dial-up support.

Price: Bundled with DESQview, \$1995; each WNIM Plus board, \$895.

Contact: Novell, Inc., 122 East 1700 S, Provo, UT 84601, (800) 453-1267; in Utah, (801) 379-5900.

Inquiry 1140.

continued

More power to the people.



ORACLE has led a revolution in PC relational database technology. More power. More portability. More connectivity. More reasons than ever to make ORACLE your corporate standard database.



New tools with even more power.

We're proud to announce our newest release—Professional ORACLE Version 5.1B. Now you can run your applications in OS/2 or in protected mode above 640K in MS-DOS. So you have more room for more powerful applications. And those same applications run unmodified on almost all workstations, minicomputers and mainframes.

Version 5.1B delivers a new level of power to your PC developers including the latest versions of:

- SQL*Forms® NEW! Enhanced 4th-generation application development environment.
- SQL*Menu® NEW! Flexible interface builder for defining complex menu systems.

• SQL*ReportWriter™ NEW! Non-procedural development and runtime powerhouse for producing any report.

• SQL*Plus® Oracle's ANSI-standard SQL query and administration tool.

• Pro*C™ The C-language pre-compiler and subroutine call interface to ORACLE.

Learn SQL on us.

Learn the language of the revolution. Order Professional ORACLE today for \$1299 and we'll include ORACLE SQL*Tutor, a nine-module PC-based SQL instruction program that sells by itself for \$199.

Try ORACLE for \$199.

Our Trial Version is identical to Professional ORACLE, but can't be used in networked configurations and allows a maximum user database size of 1 MB. It's a powerful tool for prototyping your first ORACLE application. And its price can be applied to the purchase of a full Professional ORACLE license.

ORACLE®

COMPATIBILITY • PORTABILITY • CONNECTABILITY

Call 1-800-ORACLE1, ext.4931 today.

Money-back guarantee.

If you haven't tried ORACLE yet, now there's even more reason to join the SQL revolution. More tools. More power. If ORACLE 5.1B doesn't revolutionize the way you develop PC database applications, return it within 30 days for a full refund.

Call 1-800-ORACLE1 ext.4931, or an ORACLE MasterVAR today.

Dear Oracle

Oracle Direct • 20 Davis Dr. • Belmont, CA 94002
1-800-ORACLE1, ext. 4931

Since your 30-day money-back guarantee eliminates any risk on my part, please send me the software below. Enclosed is my check, or VISA MasterCard AmEx credit card authorization. Offer valid only in the USA. Please send 5.25" High Density or 3.5" disks.

- Professional ORACLE for MS-DOS with free ORACLE SQL*Tutor for \$1299 \$ _____
- Professional ORACLE for MS-DOS Trial Version for \$199 \$ _____
- Professional ORACLE for OS/2 for \$1299 \$ _____

Professional ORACLE Requirements: MS-DOS—80286/80386 PC with MS-DOS V3.1+, hard disk, 640KB of memory and 896K extended memory required. 2.5MB of extended memory recommended (required for SQL*ReportWriter). OS/2—80286/80386 PC w/OS/2 V1.0, hard disk, 3MB memory. SQL*ReportWriter not available for OS/2 and is replaced by SQL-Report2

- Just send ORACLE SQL*Tutor for \$199 \$ _____
- Minimum Requirements: 256K PC with hard disk. Color monitor suggested.

Subtotal \$ _____

Please add appropriate sales tax \$ _____

Total enclosed/authorized (USA only) \$ _____

NAME _____ TITLE _____

COMPANY _____

STREET (no P.O. boxes, please) _____

CITY _____ STATE _____ ZIP _____

PHONE _____

CREDIT CARD NO. _____ CARD EXPIRATION DATE _____

SIGNATURE _____ TODAY'S DATE _____ BYTE.MAG _____

The first 25MHz Micro Channel[®] compatible

ALR's MicroFlex 7000

*Now we're
making waves
with IBM[®].*



At ALR, we thrive on opportunities to beat our competitors. Our 25MHz 80386[®] based MicroFlex 7000 is no exception.

Unmatched performance

Our proprietary "pre-fetch" FlexCache[™] design delivers the most efficient form of microcomputer processing. By combining a true 64-bit cache bus with 64-KB cache memory, performance increases 30% when compared to other 32-bit computers. And 64KB of high-speed cache memory enables you to

experience the fastest throughput for sophisticated applications. For those seeking large storage capacities, the MicroFlex 7000 gives the option of 120 or 300MB of disk storage using high-speed ESDI controllers with 1:1 interleave.

The most built-in features

The MicroFlex 7000 includes our super VGA controller with 800 X 600 graphics resolution and the sleek tower chassis offers the most internal expansion capabilities of any Micro Channel

system available. Our one-year warranty with unlimited technical support and On-site servicing available from Intel[®] can't be beat. So make some waves of your own at the office with ALR's MicroFlex 7000. For more information and the name and number of your local authorized ALR reseller, please call:

1-800-444-4ALR

Advanced Logic Research, Inc.
9401 Jeronimo, Irvine, CA 92718
(714) 581-6770 FAX:(714) 581-9240

For our Canadian office:
1-800-443-4CAN

For our UK office: 1-714-581-6770
For our Singapore-Asia/Pacific office:
(65) 258-1286 FAX: (65) 258-1285

FlexCache is a trademark of Advanced Logic Research, Inc. 80386 is a registered trademark of Intel Corp. IBM and Micro Channel are registered trademarks of International Business Machines Corp. Shown with optional monitor. Prices and configurations subject to change without notice. Certified FCC class A, for business use only. Copyright 1989 Advanced Logic Research.

Surfing was never this fast!

Introducing ALR's FlexCache™ 25386Z



Frankie Avalon

ALR
California
Home of the World's First 386
Advanced Logic Research Inc.

Kowabunga!

Hold on because ALR's FlexCache 25386Z is 25MHz 80386® raw power and speed. *Souped-up* with 64Kb of high-speed cache, this powerhouse motherboard is PC Magazine's 1988 winner for Technical Excellence. With the standard features of the entire Z-line consisting of our super VGA card with 800 X 600 graphics resolution, 1Mb of main memory, 3 1/2" 1.44 PS/2® compatible floppy drive and the award winning



PC Kwik® disk caching utility, the FlexCache 25386Z is ready to roll. Of course you have the option of 40-or 120Mb of fixed disk storage controlled by full-track data buffering with "look-ahead cache" and 1:1 interleave. The FlexCache 25386Z is the first 25MHz small-footprint system available right off the showroom floor for as little as \$5200 dollars. No bargaining required. Don't forget about ALR's unprecedented 3-year warranty on the motherboard or our full one-year

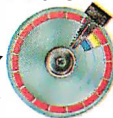

system factory warranty. You can also get On-site servicing from Intel. ALR products are sold through an international network of authorized resellers. Call today for the reseller nearest you.

1-800-444-4ALR

Advanced Logic Research, Inc.
9401 Jeronimo, Irvine, CA 92718
(714) 581-6770 FAX:(714) 581-9240

For our Canadian office:
1-800-443-4CAN
For our UK office: 1-714-581-6770
For our Singapore-Asia/Pacific office:
(65) 258-1286 FAX: (65) 258-1285

FlexCache is a trademark of Advanced Logic Research, Inc. 80386 and PS/2 are registered trademarks of Intel Corp. PC Kwik is a registered trademark of Multisoft Corp. Shown with optional monitors. Certified FCC Class A, for business use only. Prices and configurations subject to change without notice. Copyright 1989 Advanced Logic Research, Inc.

For the Integration of Fax

Three new products help you integrate fax services through your LAN. Two use intelligent machines, and one is an extension of an E-mail package.

The Facsimile Server from Interpreter bundles a Wyse 286 and a fax add-in card from Brook Trout with software groomed in the legal market. Each unit includes 1 megabyte of RAM, a 20-megabyte hard disk drive, a 1.2-megabyte 5 1/4-inch floppy disk drive, an Ethernet card (in one of several slots), a serial port, and a parallel port.

Two key features are automatic (and confidential, if you want) routing through the network to the addressee, and transparent conversion of text to editable word processing or spreadsheet formats.

Price: \$5600.

Contact: Interpreter, Inc., 11455 West 48th Ave., Wheat Ridge, CO 80033, (800) 232-4687; in Colorado, (303) 431-8991.

Inquiry 1145.

With its first product, called FaxPress, Castelle took a proprietary approach to a fax server. This reduces not only the unit's size (to 3 by 11 by 12 inches) but also its price. You forfeit only the industry-standard bus.

Each FaxPress includes two Motorola 68000 microprocessors, one acting as the fax processor and one acting as the network processor. You get 1.5 megabytes of RAM, a serial port, a parallel port, and an Ethernet board.

Price: \$3650.

Contact: Castelle, 2540 Mission College Blvd., Suite 102, Santa Clara, CA 95054, (408) 496-0474.

Inquiry 1146.



FaxPress dedicates PC service on your NetWare network.

FAXlink from cc:Mail uses the Intel Connection CoProcessor board. A single workstation on your network equipped with the board acts as a fax gateway for an entire local- or wide-area network of cc:Mail users.

It's an extension of the cc:Mail software, so you're notified when you have text or graphics just as you are with mail messages on cc:Mail. It's the same user interface. And as with the other products, there are broadcast capabilities and timed capabilities.

Price: \$995 per server.

Contact: cc:Mail, Inc., 385 Sherman Ave., Palo Alto, CA 94306, (415) 321-0430.

Inquiry 1147.

How V.22bis Modems Are Progressing

The 2400-series V.22bis modems from Racal-Vadic offer you 2400-bps asynchronous transmission over analog transmission facilities.

Of course, you get the de facto standard MNP-4 (and lower) error control and

backward compatibility to 300-bps modems. The modems are available in an internal half-height model, or as an external peripheral for the XT, AT, or PS/2s. There are also some extras, like the ability to store up to four telephone numbers.

Price: \$395.

Contact: Racal-Vadic, 1525 McCarthy Blvd., Milpitas, CA 95035, (800) 432-8008; in California, (408) 432-8008.

Inquiry 1149.

Wide-Area Network Solution Greets PCs, etc.

10-NET TCP is a single-network solution for LANs, terminal servers, PCs, and microcomputer-to-mainframe equipment.

With this TCP/IP software, you're transparently connected from 10-Net's LAN equipment to Digital Communications Associates' WAN equipment. All you see is a common interface.

The package includes software modules and utilities for TCP/IP protocols, a file transfer protocol (remote host to PC and back), Telnet terminal emulation (log-on to remote host), and simple mail transfer protocol.

Price: \$395.

Contact: Digital Communications Associates, Inc., 1000 Alderman Dr., Alpharetta, GA 30201, (404) 442-4000.

Inquiry 1150.

Frederick Engineering Shrinks a DACS

The μ DACS, a miniature version of a digital-access cross-connect switch, consists of a PC-compatible add-in card and application software.

DACSes have long been used for switching as few as 128 "T1" telecommunications lines, with each T1 defined as a stream of electrical pulses at the telecommunications-standard 1.544-mbps data rate. DACSes are priced at a hefty \$100,000 or more.

The μ DACS lets your personal computer receive as many as 16 telecommunications lines, each carrying information at the T1 rate. Then it reroutes the lines with its own transmitter. It can also switch up to 384 lines at the DS0 rate of 64 kbps.

You manipulate the μ DACS either locally through your PC or remotely on an asynchronous terminal connected through the RS-232C ports.

Applications include digital hubbing, "broadcast" cross-connect, channel drop and insert, network management, and facility data link.

Price: \$20,000, including an XT clone.
Contact: Frederick Engineering, Inc., 10200 Old Columbia Rd., Columbia, MD 21046, (301) 290-9000.
Inquiry 1148.

continued

The End of Plain Vanilla PC Graphics

More Vibrant Colors and Higher Resolution. Any Way You Scoop it.

Now, Genoa dishes up more ways to eliminate the monotony of monochrome. Or the lifeless look of low-res color. With a brilliant line-up of IBM compatible graphics cards, designed to please any palate.

The creme de la creme in performance. For CAD and desktop publishing, get the ultimate in high performance: SuperHGA™, with an on-board graphics processor. It puts ultra hi-res images on any IBM 8514-compatible display with blazing speed. At 1024 x 768

resolution with 256 on-screen colors from a palette of 16 million.

Your choice of flavors, a la any mode. Genoa serves up a full menu of SuperVGA™ and SuperEGA cards. All of which extend the IBM standards—with VGA resolutions of up to 1024 x 768 in 16 colors in both non-interlaced and interlaced modes, and up to 800 x 600 in 256 colors.

The pint-size combo package. For sparkling color and monochrome graphics in one economical half card, choose our SuperSpectrum™. It's 100% CGA, MDA and Hercules compatible, with double scanned CGA for quality game images. Plus 132-column text for full spreadsheets.

So if your graphics board is producing nothing but "board-dom," go to your dealer today and order some Genoan graphic excitement. Call (408) 432-9090 today. Or write Genoa Systems Corporation, 75 E. Trimble Rd., San Jose, CA 95131; FAX (408) 434-0997, London 44-01-225-3247; Taiwan 886-02-776-3933.

IBM is a trademark of IBM Corp. Hercules is a trademark of Hercules Technology. SuperHGA, SuperVGA 16-bit Graphics Adapter, SuperVGA, SuperEGA HiRes and SuperSpectrum are trademarks of Genoa Systems Corp.

Circle 305 on Reader Service Card

Insist on
Genoan Value.
GENOA



C++ for Unix

Guidelines C++ is now available for Unix V/386. The C++ language is a superset of C and is ANSI C compatible. C++ supports object-oriented programming with features such as classes, inheritance, member functions, constructors and destructors, data hiding, and data abstraction.

Guidelines C++ for Unix V/386 works with the standard Unix C compiler and supports cross-translation with DOS as the target system.

Price: \$495.

Contact: Guidelines Software, Inc., P.O. Box 749, Orinda, CA 94563, (415) 254-9183.

Inquiry 1110.

Semantic Checker for Mac Programmers

Programming in C on the Mac is simplified with the release of McClint, a programming tool in the C Programmer's McTool Series from MMC AD Systems.

McClint (pronounced Mic-See-Lint) semantically analyzes either single or multiple source listings in interactive or batch fashion. The program checks variable types, conditional and assignment statement usage, arithmetic operations in conditional expressions, misplaced semicolons, function argument passing, and variable initialization.

McClint automatically constructs its own prototypes for any C source code, the company reports. The program also incorporates options that let you select the program's

target system and the selective enabling/disabling of individual and/or groups of warning and error messages.

The program supports Finder and MultiFinder. With MultiFinder, the program can analyze C source files in the background while you edit, compile, or perform other tasks in the foreground.

The program also has an editing and search system that lets you create and modify C source code. Editing features include selection of tab sizes, font type and sizes, automatic highlighting of C keywords, comments, functions, Macintosh Toolbox calls, and more. The search facility supports multiple file searches, manual and automatic string replacement, and an optional Unix grep facility.

McClint runs on any Mac with System 4.2 or higher and at least 1 megabyte of memory.

Price: \$99.95.

Contact: MMC AD Systems, Box 360845, Milpitas, CA 95035, (408) 263-0781.

Inquiry 1108.

DOS Assembler Upgraded

Version 3.0 of the A86 Assembler includes support for linkable OBJ files, instruction sets for all processors in the 8086 family, assembly-time floating-point-expression arithmetic, and assembly language source file libraries. The company also reports that the process of converting MASM source files to A86 is now easier due to more compatibility features such as forward references to variables.

A86 is a shareware assembler for MS-DOS computers, written by Eric Isaacson. A86 does not require all the red-tape directives that other assemblers require, according to the company. The pro-

gram's set of OBJ defaults are compatible with most languages, so you can choose to omit the MASM red-tape directives.

Price: \$50, includes source file library tool.

Contact: Eric Isaacson Software, 416 East University St., Bloomington, IN 47401, (812) 339-1811.

Inquiry 1111.

Triple Dose of Graphics

Genus Microprogramming's trio of graphics programs let you incorporate graphics into your programs.

The PCX Programmer's Toolkit 3.5 offers over 45 routines to display, save, and print PCX bit-mapped graphics. Seven utility programs let you capture screens, display images, manage image libraries, and print image files. You can also use graphics from PC Paintbrush, scanners, clip art, or captured screens. Version 3.5 adds support for extended VGA modes that can display up to 800 by 600 pixels in 256 colors.

The program PCX Text lets you display text in graphics mode. Routines let you accept user input, scale fonts, and place text anywhere on the screen. A font editor lets you create your own text styles. You can use up to 256 different text styles on the screen at once, according to Genus.

The special-effects program, PCX F/X, lets you fade, wipe, push, roll, slide, split, crush, spiral, and explode your graphics.

The three programs sup-

port all modes of CGA, EGA, VGA, Hercules, and 8514/A graphics adapters, according to Genus. Linkable libraries are provided for a variety of languages. To run any of the three graphics programs, you need an IBM PC with a graphics card and DOS 2.0 or higher.

Price: Programmer's Toolkit 3.5, \$125; Text, \$99; F/X, \$99.

Contact: Genus Microprogramming, 11315 Meadow Lake, Houston, TX 77077, (800) 227-0918; in Texas, (713) 771-4914.

Inquiry 1109.

Prototyping in Pascal and C

ProtoGen lets you create prototypes by entering word processor-like commands in an interactive environment, according to MacCulloch. The programming tool lets you generate Turbo Pascal, Turbo C, and Microsoft C prototypes and source code with three kinds of menus.

The program treats prototypes as data and generates object files in your target language. You can make changes to prototypes with a WYSIWYG editor, and you can import screens that you've created with Dan Bricklin's Demo program.

To run ProtoGen, you need an IBM PC with 384K bytes of RAM, DOS 2.1 or higher, and a target compiler for generating code. You don't need a compiler for prototype generation.

Price: \$79.99.

Contact: MacCulloch, Prymak, Ltd., 1411 University Ave. W, Windsor, Ontario, N9B 1B8, Canada, (800) 336-1166 or (800) 225-1166; in Ontario, (519) 977-0903.

Inquiry 1112.

continued

Announcing a big leap in mouse technology.

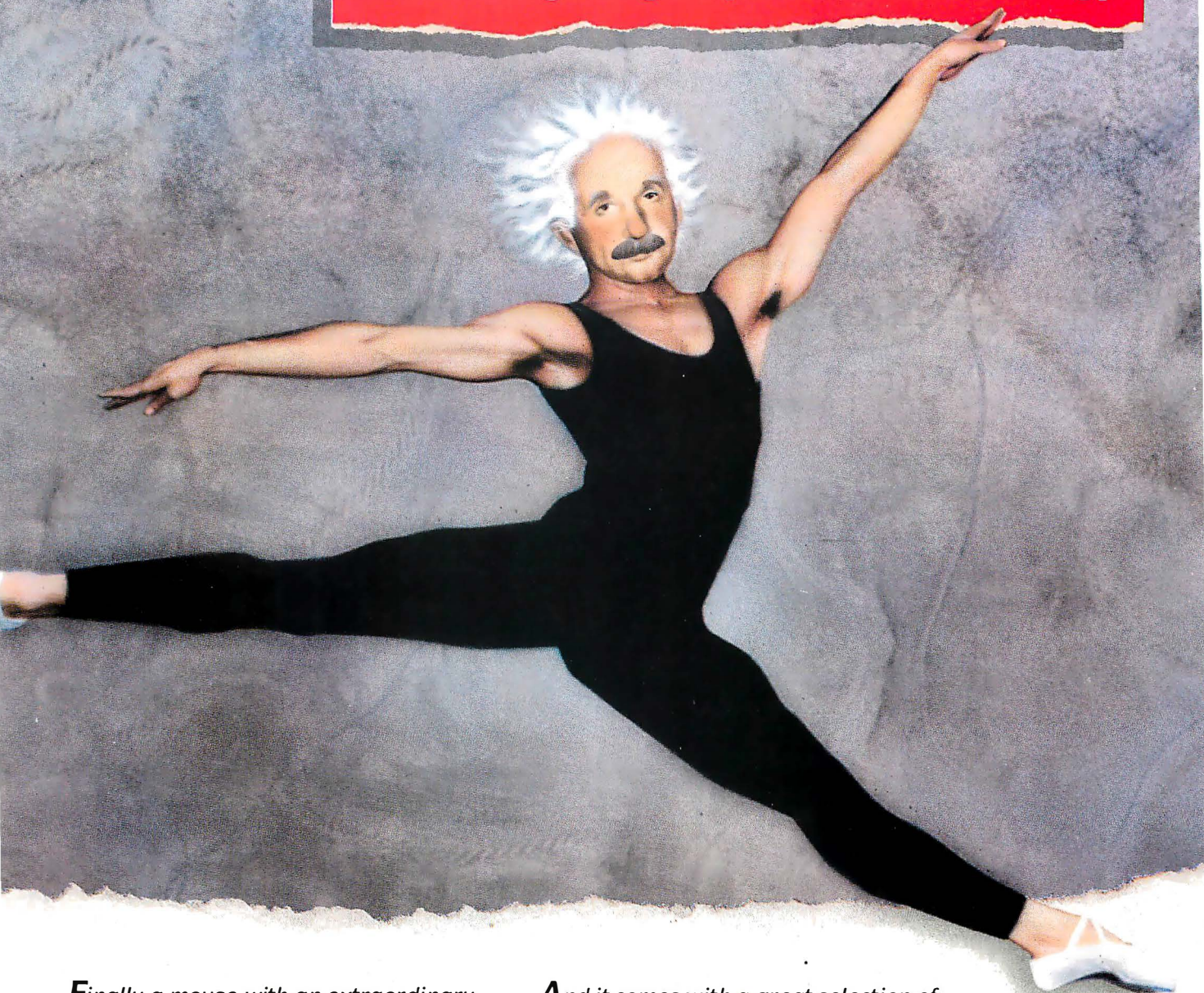

Finally a mouse with an extraordinary body and a mind to match.

The Logitech Mouse is tuned to accelerate your cursor across any screen with the mere flick of a wrist. And slow it down on arrival for pixel-point control.

It's guaranteed to work with all IBM personal computer applications.

And it comes with a great selection of MouseWare™ including Pop-Up DOS™—the ultimate DOS handler; the Mouse-2-3™ shell; 35 menus for popular keyboard-based applications; and unlimited Product Support.

*For your nearest dealer, call Logitech at:
800-231-7717*

*In California:
800-552-8885*

*In Europe:
+ + 41-21-869-96-56*

Circle 158 on Reader Service Card

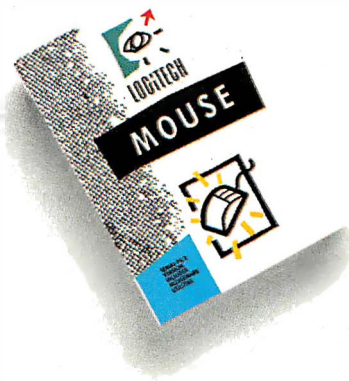



COMPAQ DESKPRO 386s



COMPAQ PORTABLE 386

The Compaq 386 line Think of it as a buffet

For more and more personal computer users, higher PC performance is no longer a luxury. New operating systems and more-demanding applications are making it a necessity.

That's one reason Compaq has created the broadest line of Intel 386™-based personal computers available. Each is designed to deliver the highest-performing solution for every

different user's needs, with unmatched industry-standard compatibility and connectivity.

Take the COMPAQ DESKPRO 386/25, for example. For users who require the ultimate in performance, it's the most powerful personal computer available. And with standard features like eight expansion slots, your choice of four different storage devices and a wide selection of graphics

controllers, it's one of the most flexible personal computers, too.

The COMPAQ DESKPRO 386/20e brings the power of a 20-MHz 386 chip to personal computer users who are outgrowing their 286-based PC's.

VGA graphics, one megabyte of memory and interfaces for a mouse and printer come standard. In a sleek package that fits where



COMPAQ DESKPRO 386/20e



COMPAQ DESKPRO 386/25

of personal computers. for the power-hungry.

other PC's this powerful won't.

The COMPAQ DESKPRO 386s is also something of a breakthrough. It's the first PC designed to offer affordable 386 performance to people who are considering 286 PC's.

Compaq even makes high-performance personal computing available for takeout. With the most advanced, full-function, 386-based portable: the COMPAQ PORTABLE 386.

But then, who's more qualified than Compaq to make a high-performance PC to suit any taste? After all, we created the world's first 386-based personal computer back in 1986. Since then, we've emerged as the world leader in high-performance computing. That's why more FORTUNE 1000 firms have added Compaq to their approved vendor lists than any other brand.

To satisfy your hunger for more power, call 1-800-231-0900, Operator 86. In Canada, 1-800-263-5868, Operator 86. We'll give you the location of your nearest Authorized COMPAQ Computer Dealer and a free brochure.

COMPAQ® and COMPAQ PORTABLE 386® are trademarks of Compaq Computer Corporation. Intel® and Intel 386 are trademarks of Intel Corporation. ®Registered U.S. Patent and Trademark Office. ©1989 Compaq Computer Corporation. All rights reserved. COMPAQ DESKPRO 386/25 graphics ©1988 Accent Software, Inc.

COMPAQ

It simply works better.



Talk to your customer instead of your computer

Control your IBM PC while you control your audience. All by yourself, you can give picture-perfect, PC-assisted sales presentations, make super group demonstrations, or even teach classes. In every case your attention will be focused on your audience, not on your PC.

The secret is Remote Keyboard... a hand-held control device for running and manipulating programs on your PC or compatible from as far away as 50 feet.

A fingertip touch on a button lets you display, alter or change data in the blink of an eye. You can roam the room, keeping in eye contact with your audience while controlling your computer with Remote Keyboard's infrared signals.

"It's neat," Remote Keyboard users say. They're right, too. It fits the palm of your hand and is UL-listed and FCC-approved. With Remote Keyboard, you don't need an aide at the keyboard. You're in control of the audience and your PC.

It installs in less than a minute — without tools! Even if you're all thumbs, Remote Keyboard is simple to install. It has just three components — your wireless, hand-held device, a receiver which plugs into your PC's serial interface, and a software driver on a diskette. Put it together, touch a button, and you're in complete control.

Pay more attention to your prospects, and sell more successfully! Remote Keyboard is a wonderful teaching tool, too, and a must for PC-assisted product demonstrations.

JUST \$395...30-DAY MONEY-BACK GUARANTEE...USE YOUR CREDIT CARD.

This handy device is just \$395.00 plus \$5.00 for shipping and handling. It comes with a 1-year limited warranty. So put yourself in control...order RISK-FREE now by calling:

(800) 331-3903

FORTE
COMMUNICATIONS

680 W. Maude Avenue • Sunnyvale, California 94086
Phone (408) 733-5100 • FAX (408) 733-5600

Remote Keyboard is a trademark of Forte Communications, Inc.
IBM and IBM PC are trademarks of IBM Corporation. © 1989 Forte Communications, Inc.

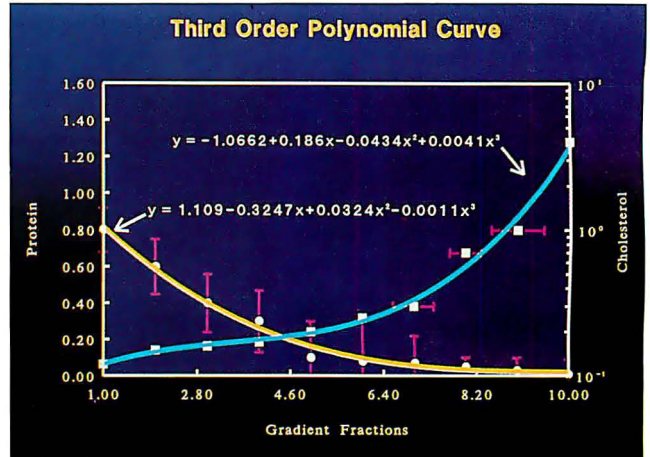

SlideWrite Plus is presentation graphics software created for scientists and engineers.

Graphics from the Lab

Advanced Graphics Software's latest version of SlideWrite Plus is aimed at scientists and engineers who need to produce graphs and charts for publication.

The enhanced version 3.0 has over 100 new features, including increased font support, use of 30 hardware fonts, improved color support, more line types and thicknesses, and more fill patterns.

The 16 software fonts that come with the program can all be accessed at once. Version 3.0 now supports 16 foreground and 16 background colors. Fill patterns include more plotter hatch patterns and halftones for the Hewlett-Packard LaserJet printer and other raster output devices.

Equation plotting capabilities let you plot any equation in the form of $y=f(x)$. You can define up to 12 equations and control the number of points generated for smooth plotting, according to Advanced Graphics Software.

A curve-fitting feature lets you draw a smooth curve through all your data points; you can specify line thicknesses and patterns of each curve. Then you can ask the program to display and print

the numbers used to draw the curvefits and equations.

ASCII data can be read into a graph, and you can import TIFF, PCX, and CGM files and use them for special effects in charts. The program can calculate mean, standard deviation, and standard error on the fly when reading in an ASCII data file.

The program comes on three disks, one of which includes a library of figures and sample charts. SlideWrite Plus 3.0 runs on the IBM PC with DOS 2.0 or higher and at least 390K bytes of free RAM. It also supports a mouse, if you have one.

Price: \$445.

Contact: Advanced Graphics Software, 333 West Maude Ave., Suite 105, Sunnyvale, CA 94086, (408) 749-8620.

Inquiry 1105.

Least Squares Regression Analysis

FitAll is available in two versions: The Standard Edition (SE) fits data to 20 different built-in functions with over 50 variations. The Research Edition (RE) lets you modify the program so it will fit data to almost any function. The RE comes in source

continued

Reach for ultimate portability

Systems Start at \$790.00!



120 MBytes of power, speed and security in a revolutionary, removable hard drive.

At last, the Disk Pack gives you everything you've always wished for in a data storage system. The speed and high storage capacity of a hard drive. The ease and convenience of a floppy diskette. And the safety of a tape backup. All wrapped up in a state-of-the-art rugged unit, about the size of a paperback book. Designed to make your life a lot simpler and more secure.

True portability is here

Just picture this: With the Disk Pack you carry your whole work environment with you, wherever you go. All your files, all your data stay organized and configured just the way you created them. Between your office and remote sites. Or home. Or another department. You can even mail a Disk Pack. It's that rugged.

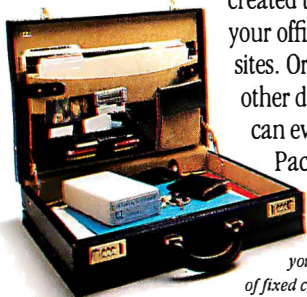

The Disk Pack frees you from the constraints of fixed computers. Your whole work environment fits in the palm of your hand.

Total security for your data

Simply slide out a Disk Pack module and lock away your entire business customer base and payroll figures in a drawer or safe. Same for lawyer,

banker or accountant sensitive data and Uncle Sam confidential information. All fully secured in a snap.

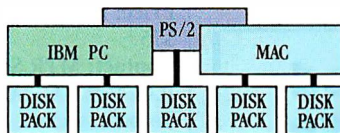

Get full data portability and security on the computer of your choice. Macintosh, PC-Compatible or PS/2.

Blazing speed Rock-solid reliability Limitless expansion

Breakthrough technology makes the Disk Pack four to five times more reliable than other removable products. Access times as low as 13 ms make it one of the fastest hard drives on the market. The Disk Pack doesn't limit you to a single storage capacity either. You can interchange 20-, 40-, 80- or 120-MByte modules in your

system and between systems. Link modules up for a whopping Half-GByte + of on-line data. Store them for unlimited off-line data. And do lightning-fast data backups.

That's not all. The Disk Pack turns a shared computer into your fully personal machine within seconds. It's ideal for space grabbing applications such as color graphics, CAD, or music. One Disk Pack module does the job of 100 diskettes. Ten times faster. And with a lot less hassle.



The Disk Pack is ideal for data security. Lock it away and forget about accidental or intentional data loss.

And thanks to the Disk Pack's unique architecture, you'll use it equally well on any Mac, Apple, PC-compatible or PS/2 computer. It's that advanced.

Outside the USA, contact IEF, Tel: (33) 1 45 57 14 14
217 Quai de Stalingrad 92134 Issy, France

For more information call

1-800-322-4744

IEF DISK PACK®

The new standard in data storage technology

MEGADRIVE

S Y S T E M S
11693 San Vicente Blvd, Suite 370
Los Angeles, CA 90049
Disk Pack is a trademark of IEF



YES! I want to know more about Mega Drive Systems' new data storage technology. Please rush me more information about the Disk Pack and your free booklet "20 Valuable Facts About Hard Disk Care and Maintenance" today.

Name _____
Company _____
Address _____
City _____ State _____ Zip _____
Phone (____) _____

Mega Drive Systems, Inc.

11693 San Vicente Blvd, Suite 370
Los Angeles, CA 90049 (213) 556-1663

Number of Micros _____ Mac _____ PC _____

Protect Your Copies of **BYTE**

NOW AVAILABLE: Custom-designed library files or binders in elegant blue simulated leather stamped in gold leaf.

Binders—Holds 6 issues, opens flat for easy reading.
\$9.95 each, two for \$18.95, or four for \$35.95.



Files—Holds 6 issues.
\$7.95 each, two for \$14.95, or four for \$27.95.



Order Now!

Mail to: Jesse Jones Industries,
Dept. BY, 499 East Erie Ave.,
Philadelphia, PA 19134

CALL TOLL FREE (24 hours):
1-800-972-5858

Please send _____ files;
binders for BYTE magazine.

Name: _____

Enclosed is \$ _____.
Add \$1 per file/binder for postage and
handling. Outside U.S.A. add \$2.50 per
file/binder (U.S. funds only please).

Address: _____
(No Post Office Box)

Charge my: (minimum \$15)

City: _____

____ American Express
____ Visa _____ MasterCard
____ Diners Club

State: _____ Zip: _____

Satisfaction guaranteed. Pennsylvania residents add 6% sales tax.
Allow 5-6 weeks delivery in the U.S.

Card # _____

Exp. Date _____

Signature _____

BYTE

WHAT'S NEW

SCIENCE AND ENGINEERING

code, which you must compile with TurboPascal.

Both versions of FitAll provide three types of weighting schemes; report standard deviations of the resolved parameters and fit; and make two-dimensional graphs of the data, the fit, and the residuals. Both versions generate calibration graphs and tables and can export tables and graphs to WordPerfect 5.0.

Both the FA-SE and the FA-RE support CGA, MCGA, EGA, VGA, and Hercules graphics. The FA-SE uses an 8087 math coprocessor, if you have one.

To run FitAll, you need an IBM PC with DOS 2.0 or higher, 512K bytes of RAM, and a graphics adapter. To run FA-RE, you need at least a 1.2-megabyte hard disk drive and Turbo Pascal 4.0 or higher.

Price: FA-SE, \$50; FA-RE, \$75.

Contact: MTR Software, P.O. Box 902, Station P, Toronto, Ontario M5S 2Z2, Canada, (416) 924-2481.

Inquiry 1104.

Engineering Data Software

Tech*Graph*Pad combines data-retrieval, data-manipulation, and data-output capabilities. Version 3.0 includes a worksheet that lets you retrieve data from Lotus 1-2-3, Symphony, or Quattro, an improved user interface, user-selectable color control, and support for Hewlett-Packard output devices.

Other enhancements include the ability to read and plot an unlimited number of data points per set, and the ability to import binary or two's complement data files from data-acquisition devices.

Tech*Graph*Pad runs on the IBM PC with 512K bytes of RAM and DOS 2.1 or higher.

Price: \$395.

Contact: Binary Engineering, 100 Fifth Ave., Waltham, MA 02154, (617) 890-1812.

Inquiry 1103.

continued

Introducing the Smallest 80386 based PC Compatible Single Board Computer Only 4" x 6"



Quark/PC® II

- VGA® VidedColor LCD Controller
- SCSI Hard Disk Control
- Up to 4 Mbytes Memory and more

To order or enquire call us today.
Megatel Computer Corporation
(416) 745-7214 FAX (416) 745-8792

174 Turbine Drive, Weston, Ontario M9L 2S2

Distributors

Germany — Tech Team (06074) 98031 FAX (06074) 90248
Italy & Southern Europe — NCS Italia (0331) 256-524 FAX (0331) 256-018
U.K. — Densitron (0959) 76331 FAX (0959) 71017
Australia — Asp Microcomputers (03) 500-0628 FAX (03) 500-9461
Denmark — Ingeniorfirmaet (02) 440488 FAX (02) 440715
Finland — Digipoint (3580) 757 1711 FAX (3580) 757 0844
Norway — AD Elektronikk (09) 877110 FAX (09) 875990
Sweden — (040) 97 10 90 FAX (040) 13 90 38

Quark is a registered U.S. trademark of F. & K. MFG. Co. Ltd. VGA is a registered trademark of IBM Corp.

megatel

Theorist Joins the Macintosh Algebra Arena

With Theorist, you can enter equations naturally and manipulate them with a click of a mouse, according to Allan Bonadio Associates, publishers of Expressionist.

Theorist files, called notebooks, store the equations, their graphs, and supporting text and pictures.

To graph an equation, you select the equations desired and pick one of six menu options for graphs. There are five different types of two-dimensional graphs included, along with one type of three-dimensional graph. You can draw graphs in black and white or in gray scales or color on the Mac II. You can

examine the graphed equations by scrolling with a hand cursor, which moves the two-dimensional graph sideways or up and down to rotate the three-dimensional graph.

Theorist differs from other Macintosh algebra programs in that it requires only 1 megabyte of memory, offers an easy-to-use user interface, and will be priced lower. Allan Bonadio Associates expects Theorist to ship this summer.

Price: From \$130 to \$500.

Contact: Allan Bonadio Assoc., 814 Castro St., San Francisco, CA 94114, (415) 282-5864.

Inquiry 1106.

The smart buy for PC Power Protection is now . . .

The Smart UPS For LAN's

. . . Reliable Protection From Data Loss

MINUTEMAN[®]
UNINTERRUPTIBLE POWER SUPPLIES

**INTRODUCING
1KVA
ON-LINE UPS**

TOTAL POWER PROTECTION:

- BLACKOUTS
- BROWNOUTS
- OVERLOADS
- OVERVOLTAGE
- SURGES/SPIKES
- EMI/RFI

"For All Sensitive Electronic Equipment"



- A unique software package that interfaces your LAN's and Minuteman UPS system for an automatic and orderly network shutdown due to power failures . . . before data loss occurs!
- Compatible with SCO XENIX 2.2.3
- Compatible with Novell Systems: ELS 2.12 and above
Advanced Netware 2.10 and above
SFT Netware 2.10 and above
- Selectable power loss warning times and shut-down times
- Instantaneous user notification
- Also interfaces to Wide Area Networks
- Auto Shutdown of UPS for unattended operation
- The only software available that supports ELS Level II
- No Novell monitoring hardware required
- Network Manager Suggested Retail Price when purchased with a Minuteman UPS Model: \$199

| Power Output | 120 Volt Models | 230 Volt Models |
|--------------|-----------------|-----------------|
| 250 WATT | \$ 379.00 | \$ 429.00 |
| 300 WATT | \$ 549.00 | N/A |
| 500 WATT | \$ 699.00 | \$ 799.00 |
| 600 WATT | \$ 899.00 | \$1049.00 |
| 900 WATT | \$1249.00 | N/A |
| 1000 WATT * | \$2249.00 | \$2549.00 |
| 1200 WATT | \$1499.00 | \$1749.00 |
| 1600 WATT | \$1999.00 | \$2299.00 |

* On-line model **Suggested Retail**

- One millisecond transfer time *
- Synchronized sinewave *
- Full one year warranty
- Order-Ship same day

* 250 watt and 500 watt units offer 4 msec transfer time, PWM waveform



PARA SYSTEMS, INC.

1455 LeMay Drive
Carrollton, TX 75007

Telephone:
(214) 446-7363

1-800-238-7272

FAX: (214) 446-9011

TELEX: 140275 OMEGA

**You Want A Laser Printer
With Faster Processing Speed,
Sharper 400 dpi Resolution
And More Powerful Functionality.
But You Think
You Can't Afford It.**

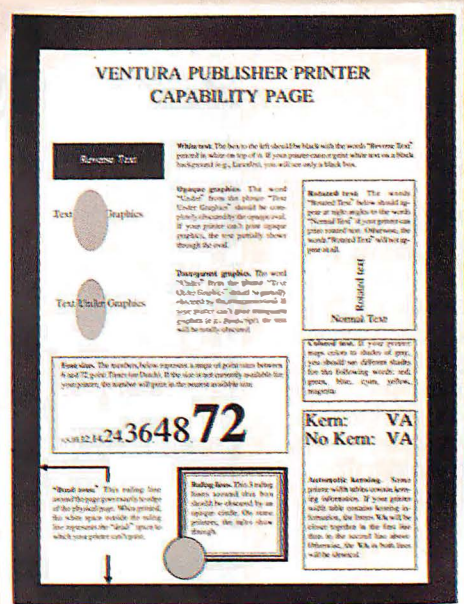
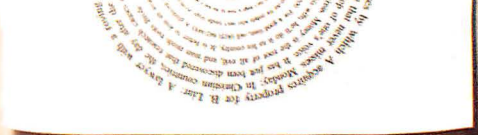
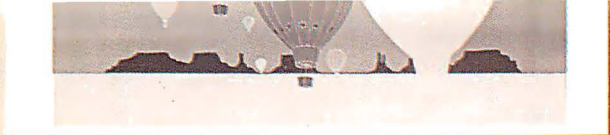

- ▲ You'll see complex graphics reproduced with unbelievable sharpness.
- ▼ You'll have the power to integrate text and graphics in bold, new ways.



PAGEMAKER IS SET UP TO create work that mimics the way professional designers work with a laser printer. With a desk emulation capable of 600 dpi resolution, the computer screen becomes a blank page on a professional, accompanied by a toolbar of design tools. A point-and-click interface allows you to create, modify, and delete multiple columns of varying widths, adding page numbers, and more. Then the printer fills the page with the real graphics created with other professional printers, complete with halftone and registration marks.

PEOPLE CAN CHOOSE FROM A NUMBER OF FEATURES to raise the quality of their printed materials. Registration and halftone marks, words for development, outlines, and screens, leaving white and black space between lines and between words for improved readability and appearance of text. PageMaker outlines words in red, yellow, or blue graphics to fit the printer's font, show lines, show lines, and fill them with patterns or dots of gray, all with the same quality and color accuracy, without resorting to the original word processor.

DESIGNERS AND COMPOSITORS Alike have benefited from PageMaker as the most realistic way to publish high quality, low cost materials. With an emphasis on speed, convenience and simplicity in the first case, more setting means a valuable time of publication. More time for business to sell your books.

PAGEMAKER: WHERE DESKTOP PUBLISHING BEGINS

ADDRESS INFORMATION in North America, both the leading publishing industry with PageMaker page layout software that allows individuals and businesses to create professional-looking publications in-house. PageMaker's introduction into the market has met with a great deal of industry acceptance, particularly from the U.S. press. In fact, the computer industry's influential magazine, *Graphic Arts Technology*, named it the "Year's Software Product" of the Year (October 1987).

THE ADVANTAGE of desktop publishing, now controlled by AlphaGraphics and PageMaker, is that it gives you the tools you need to produce professional-quality materials. From newsletters, catalogs, forms, and mailings, to corporate manuals and magazines, know the advantages in graphics on your desktop computer and how PageMaker, the backbone of PageMaker, makes this the first time, people could publish their own quality special publications with ease.

Desktop Publishing Sales in Billions of Dollars



- ▲ The ACE language can do virtually anything you want with type—at speeds you never thought were possible.
- ▼ Business presentation graphics can really come alive.

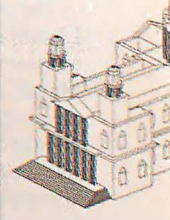
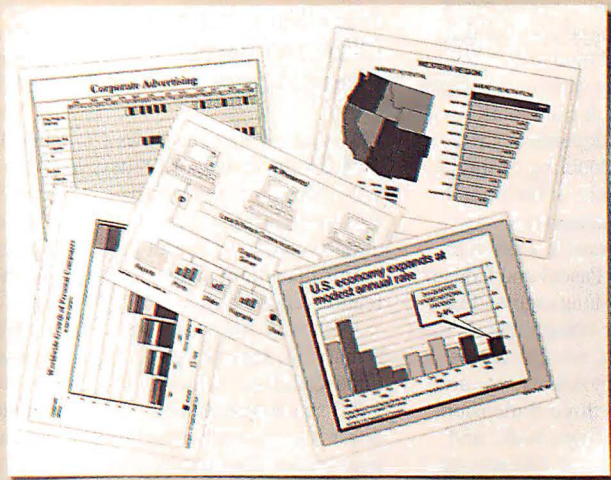

Allow Us To Draw Some Conclusions.

The Genicom 6142: The Industry's Best Value In A Laser Printer. Finally, someone built a laser printer with everything you need—including an affordable price.

The Genicom 6100 Series gets its power from the unique combination of raster image processing hardware and the efficient ACE page description language. With a powerful font mechanism for scaling and rotating capability, it can process integrated text and graphics significantly faster than comparable printers.

Your work will look much more impressive. Its 400 dpi resolution, compared to 300 dpi printers, yields a superior quality image—a 78% improvement.

Compatibility is no problem. ACE driver kits are included so it works with the major desktop publishing and word processing software. And emulations are available for HP LaserJet II®, HP GL®, Diablo 630®, and IBM GF®.

Call us today for more information or for the reseller nearest you. Then you can draw your own conclusions about the remarkable Genicom 6142.



GENICOM
Ideas that work as hard as you do.

Genicom Drive, Waynesboro, Virginia 22980
Toll-free 1-800-4-GENICOM.
Reseller and Dealer inquiries invited.

Plot Demographics with Analysis Tool

P SRC Software's IPSS (Interactive Population Statistical System) is a graphics-based demographics package for business marketers, demographers, and educators. The program can plot the changing demographics in a market area, study the implications of a growing or declining population in a region, and forecast a portion of product demand driven by changing population, the company reports.

Demographic measures of the program include: total births, child mortality, child/woman ratio, crude birth rate and death rate, total deaths, age dependency ratios, population doubling timing, life expectancy at birth, and many more categories.

The program is written in LightSpeed Pascal and Consul-assembly language and is MultiFinder-compatible. With the program, you can create population pyramids, bar and line graphs, three-dimensional population pyramids, and lexis surface and 100 percent surface graphics.

You can use the program to paste graphics directly into spreadsheet or word processing programs and automatically convert them to numerical data.

IPSS works on the Mac Plus, SE, II, or Ix with two 800K-byte floppy disk drives or a hard disk drive and requires 1 megabyte of memory.

Price: IPSS, \$295; IPSS II, \$395 (requires a 68020/68030 processor and a 68881/68882 math coprocessor).

Contact: Population and Society Research Center, Bowling Green State University, Bowling Green, OH 43403, (419) 372-2497.

Inquiry 1116.

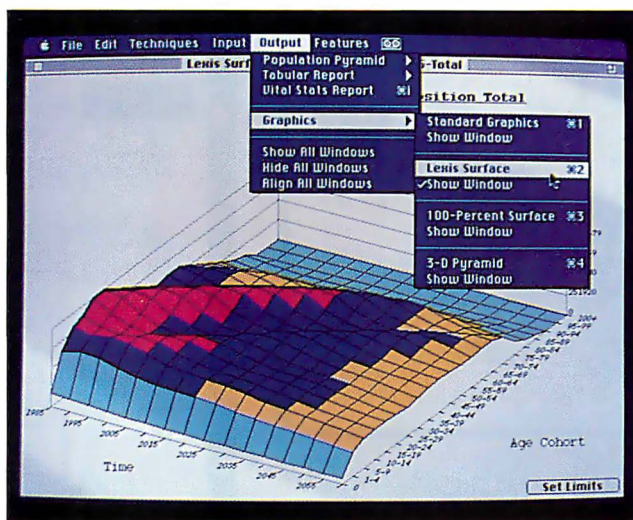

Demographic statistics graphically displayed with IPSS.

New Spreadsheets Claim to Beat Latest Lotus

As spreadsheet users wait for the arrival of Lotus 1-2-3 version 3, two companies have released three-dimensional spreadsheet programs that claim many features of the next 1-2-3.

Computer Associates International reports that its SuperCalc5 coexists with 1-2-3 so completely that it doesn't require an import/export feature for Lotus worksheets. SuperCalc5 automatically recognizes and adjusts for .WKS and .WK1 file ex-

tensions. Other features include multiple spreadsheet linking, three-dimensional graphics, and built-in auditing and debugging.

You can mix SuperCalc5 and 1-2-3 menu commands from the menu and in macros. And because macro conversion is reversible, you can move macros back and forth between the two spreadsheet programs.

SuperCalc5's three-dimensional linking method allows you to link spreadsheets in memory or on disk. Up to 255 spreadsheets can be linked.

The program offers more than 100 two- and three-dimensional graphics.

SuperCalc5 will run on

any IBM PC or compatible with 512K bytes of RAM, a hard disk drive, and DOS 3.0 or higher.

Price: \$495.

Contact: Computer Associates International, Inc., 1240 McKay Dr., San Jose, CA 95131, (800) 531-5236; in California, (408) 432-1727.
Inquiry 1114.

Mosaic Corp.'s Twin Level III also includes many of the promised features of the next Lotus 1-2-3, including the ability to view several spreadsheets at once, background and minimal recalculation, linked files, and three-dimensional worksheets.

One feature allows you to link forms into the database or user-defined functions. Another feature, called Easyform with Data Entry, allows you to use spreadsheet cells as a form.

Twin Level III requires 375K bytes of RAM and will run on any IBM PC or compatible with dual floppy disk drives.

Price: \$249.

Contact: Mosaic Marketing, Inc., 1972 Massachusetts Ave., Cambridge, MA 02140, (617) 491-2434.
Inquiry 1200.

continued

Word Processor for Windows Imports Graphics

Myrriad, a word processor that requires Microsoft Windows, has several features that you would normally associate with desktop publishing programs. It can import and export graphics and text through the clipboard and wrap text around an imported image. By using the program's multiple-document windowing capabilities, you can cut sections of one document and paste them into another, according

to the program's publisher.

Myriad can also add borders from hairline to about 1/3-inch width around the graphical image. Borders are used to associate a graphics frame with enclosed text—if you move the paragraph or other body of the document, the frame moves with it. Myriad also provides style sheets, document merge, table and index generation, full-page preview, headers and footers, automatic footnote placement,

and WYSIWYG presentation.

Included with the program is Beckman Associates' Thesaurus & Speller. Myriad requires Microsoft Windows 286 or 386 version 2.03 or higher. The company recommends 1 megabyte of disk space.

Price: \$249.95.

Contact: Beckman Associates, Ltd., 928 Oakcrest St., Suite A, Iowa City, IA 52246, (319) 354-5116.
Inquiry 1113.

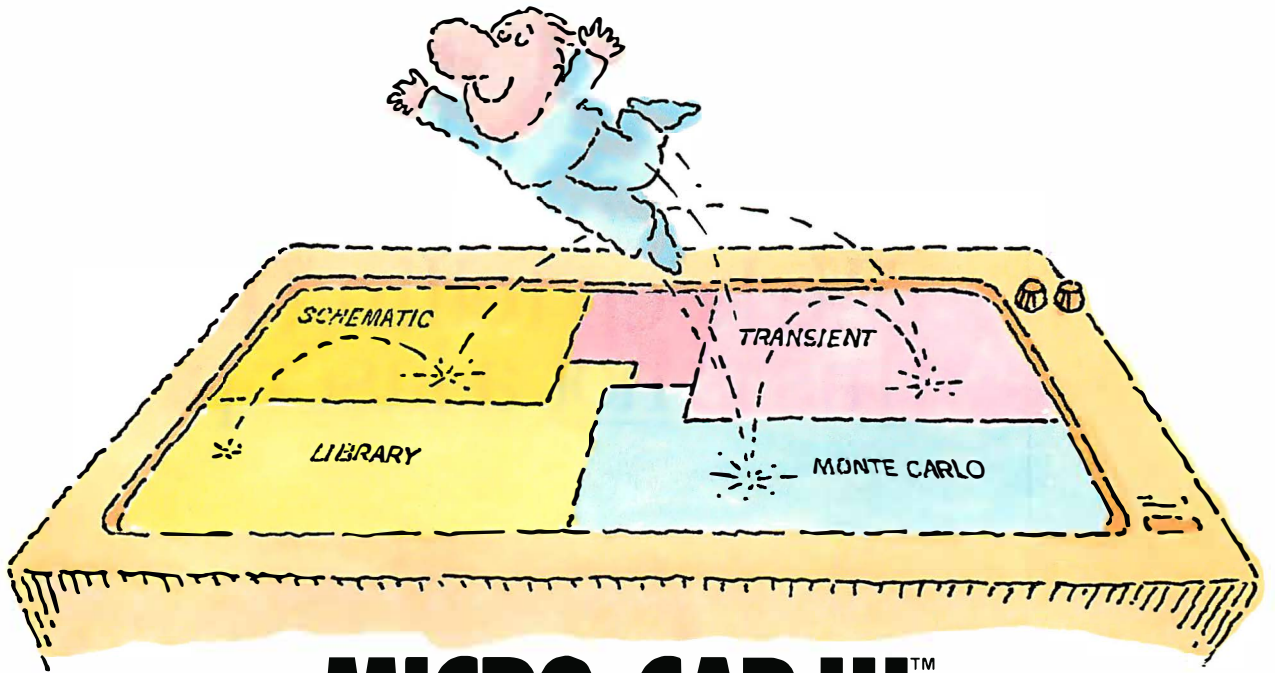

MICRO-CAP III.™ THIRD-GENERATION INTERACTIVE CIRCUIT ANALYSIS. MORE POWER. MORE SPEED. LESS WORK.

MICRO-CAP III,™ the third generation of the top selling IBM® PC-based interactive CAE tool, adds even more accuracy, speed, and simplicity to circuit design and simulation.

The program's window-based operation and schematic editor make circuit creation a breeze. And super-fast SPICE-like routines mean quick AC, DC, Fourier and transient analysis — right from schematics. You can combine simulations of digital and analog circuits via integrated switch models and macros. And, using stepped component values, rapidly generate multiple plots to fine-tune your circuits.

We've added routines for noise, impedance and conductance — even Monte Carlo routines for statistical analysis of production yield. Plus algebraic formula parsers for plotting almost any desired function.

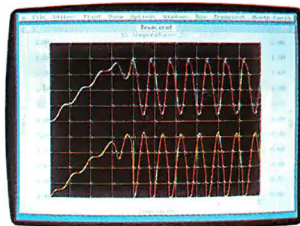

Transient analysis

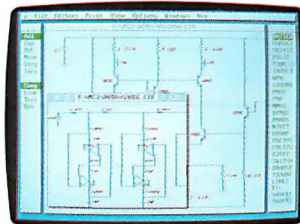

Schematic editor

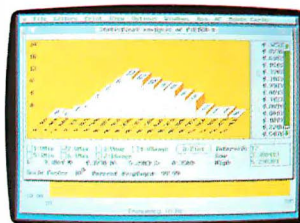

Monte Carlo analysis

Modeling power leaps upward as well, to Gummel-Poon BJT and Level 3 MOS — supported, of course, by a built-in Parameter Estimation Program and extended standard parts library.

There's support for Hercules®, CGA, MCGA, EGA and VGA displays. Output for laser plotters and printers. And a lot more.

The cost? Just \$1495. Evaluation versions are only \$150.

Naturally, you'll want to call or write for a free brochure and demo disk.

spectrum

1021 S. Wolfe Road,
Sunnyvale, CA 94086
(408) 738-4387

MICRO-CAP III is a registered trademark of Spectrum Software.
Hercules is a registered trademark of Hercules Computer Technology.
IBM is a registered trademark of International Business Machines, Inc.

We keep telling people
this is not a laser printer.

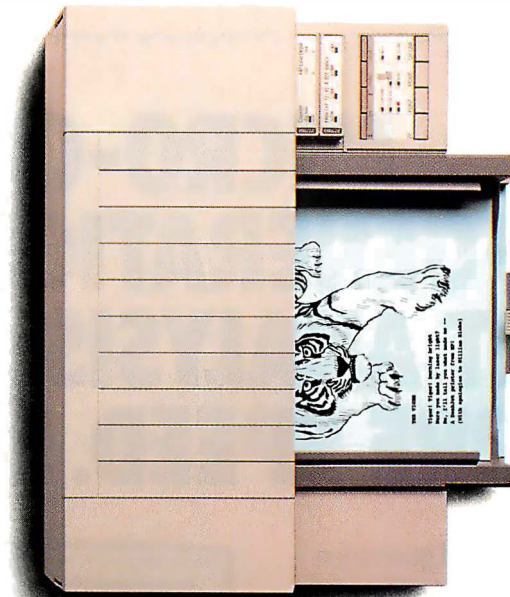

The new \$995 HP DeskJet PLUS Printer.

But they keep looking at the evidence.



Mr. Arnold R. Jones
220 Bush Street, Suite 845
San Francisco, CA 94104

Dear Reader:

Imagine being able to put out merged text and graphics that look in fact, that your clients will think you're using a laser printer. You're using the \$995 HP DeskJet PLUS printer instead.

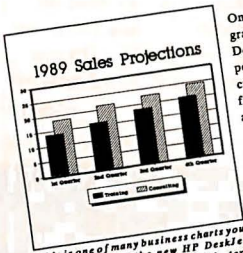

One reason you can graphs around so DeskJet PLUS printer popular software create your messages favorite program and beautifully.

We call it a pe small price, fo

Of course, w how good it trip to your for yourse

This is one of many business charts you can print out on the new HP DeskJet PLUS printer. Software for this test and graphics demonstration by Harvard Graphics.

Sincerely,

Alan Grube
Alan Grube

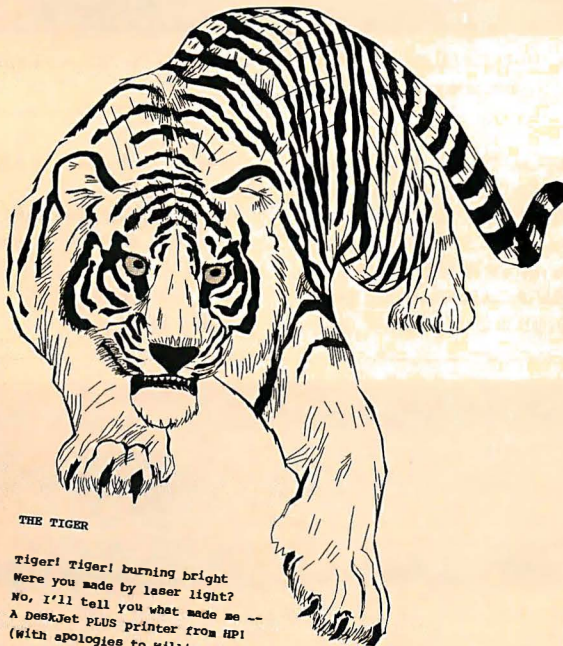

THE TIGER

Tiger! Tiger! burning bright
Were you made by laser light?
No, I'll tell you what made me --
A DeskJet PLUS printer from HP!
(with apologies to William Blake)

MegaCorp 1988 Sales History

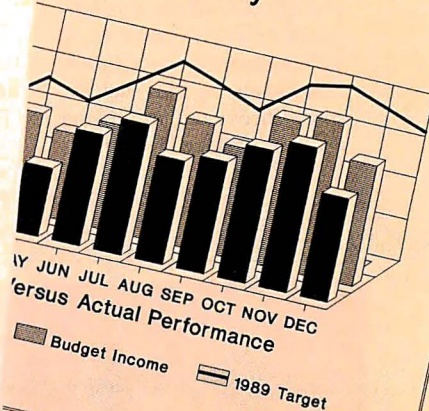

You won't believe your eyes (or ears), either. The HP DeskJet PLUS printer gives you the same crisp, black lettering. Clean, sharp graphics. And whisper-quiet operation. But it uses advanced inkjet technology to supply these laser-like qualities for the price of a 24-wire printer.

For just \$995, you get 300 dpi in a trim 15-pound package that's twice as fast as the original. What's more, it has built-in landscape and improved font selection. Including ten built-in fonts and over 100 optional fonts, with sizes up to 30 points. And its 20,000-hour MTBF

assures a long, happy life.

So call 1-800-752-0900, Ext. 276J for the name of your nearest authorized HP dealer. Then judge the HP DeskJet PLUS printer for yourself.



Timberline and Autodesk Interface

With the Precision CAD-Link interface, building estimators can take off dimensions and building specs electronically from any AutoCAD drawing files. Using Precision Estimating Plus software from Timberline, Precision CADlink links similar information needs of various building phases.

While using the interface, you still have all the capabilities of AutoCAD available, as well as the facilities of Precision Estimating Plus such as spreadsheet-based estimating and user-designed formulas.

Precision CADLink is compatible with AutoCAD version 10 and with the AEC

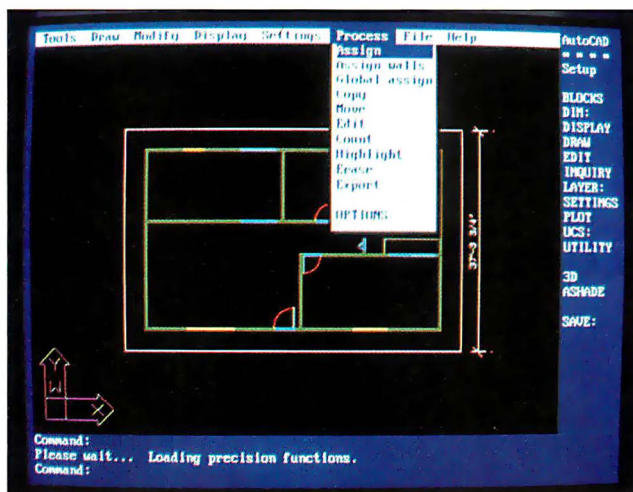

Precision CADLink integrates information for building designers and construction cost estimators.

template for full architectural drawing capabilities.

To run the interface, you need AutoCAD version 10 running on an IBM PC with 640K bytes of extended memory, DOS 2.1 or higher, and

at least 512K bytes of RAM.

Price: \$490.

Contact: Timberline Software Corp., 9405 Southwest Gemini, Beaverton, OR 97005, (503) 644-8155.

Inquiry 1118.

Two for the Mac

Two recently released programs offer different approaches to CAD on the Macintosh.

Claris CAD is a straightforward two-dimensional design program that includes mouse and keyboard entry, the ability to construct fillets, tangents, and perpendiculars, and auto-dimensioning. The program offers over 5000 methods for creating and editing geometry, according to Claris.

The program supports freehand and object-oriented sketching. You can read all files created by MacDraw and output them in PICT format. IGES and DXF translators are

continued



Protect the one you love.

Yours is not just any computer. It's your friend. Your confidant. Your business partner.

You wouldn't be without it.

But it can happen in a flash. A sudden storm, distant ditch digger, motor, or even a toy metallic balloon can send data-killing, component-killing electric surges and sags smack into your computer. Even knock it out altogether.

It's a matter of time before this happens to you. So protect your friend with Emerson's

new low-cost SW1000 Uninterruptible Power System. Only 2¼ in. high, it fits smartly right under your PC's monitor for less than \$700.

In a brownout or blackout, a battery will instantly take over giving you ten minutes or more to shut down your computer.

Call 1-800-Back-UPS for the Emerson dealer nearest you. Before it's too late.

EMERSON
Computer Power
Computers Won't Run Right
On The Wrong Fuel.

*Limit 1 per customer. Offer expires September 30, 1989. Dealer: For reimbursement, forward copy of sales slip, UPS serial No., and customer name, address and phone number to: Marketing Services, Emerson Computer Power, 3300 S. Standard Street, Santa Ana, CA 92705.

© 1989 Emerson Electric Co.

MAX·VGA™ adapter works with flying colors



providing VGA® compatibility equal to IBM's own VGA adapter

with features that make MAX·VGA unequalled by any other VGA adapter

- Operates up to 400% faster than IBM VGA adapter
- Extended modes (require 512K of RAM): 1024x768 – 16 colors; 640x480 – 256 colors
- Full BIOS and REGISTER compatibility with MDA®, CGA®, MCGA®, EGA®, VGA® and Hercules®
- Works with either XT™ or AT®: 16 bit design – auto-detects and adapts to 8 bit slots
- High-res drivers for popular software

For more information about Maxon's new MAX·VGA adapter, phone (415) 377-0269, FAX (415) 377-0236 or write to Maxon Systems, Inc., One Waters Park Drive, Ste. 117, San Mateo, CA 94403.

maxon®
SYSTEMS INCORPORATED
A Wholly Owned Subsidiary of Maxon Electronics Co. Ltd. of Korea

The following are trademarks or registered trademarks of the companies listed: IBM, XT, AT, VGA, MDA, CGA, MCGA and EGA – International Business Machines Corporation; Hercules – Hercules Computer Technology, Inc.; VGA Wonder – ATI Technologies, Inc.; FastWrite VGA – Video Seven Inc.; VGA Professional – Paradise Systems, Inc.; MAX·VGA – Maxon Systems, Inc.; and PC TECH JOURNAL – Ziff Communications Company.

| VGA COMPATIBILITY EVALUATION SUITE – PC TECH JOURNAL® (November, 1988 issue) | | |
|---|--------------------------|-------------------|
| VGA ADAPTERS | TESTS PASSED | TESTS FAILED |
| IBM® VGA | 1-12, 14-18 | 13* |
| MAX·VGA™ | 1-12, 14-18 | 13* |
| ATI® VGA WONDER™ | 1-5, 7, 9-12, 15, 17, 18 | 6, 8, 13*, 14, 16 |
| VIDEO SEVEN® FASTWRITE VGA™ | 1-5, 7-12, 15-18 | 6, 13*, 14 |
| PARADISE™ VGA PROFESSIONAL™ | 1-11, 14-18 | 12, 13* |

*Refers to "Hardware General Register" – reserved control registers and vertical interrupt do not affect operation as seen by applications programs.

optional, enabling you to import or export files to and from AutoCAD and other CAD programs. Claris reports that the number of layers is limited only by memory.

Claris CAD runs on the Mac Plus, SE, or II with at least 1 megabyte of memory. Recommended system software includes System 6.0, Finder 6.1, MultiFinder 6.0, and LaserWriter 5.2.

Claris CAD comes with a tutorial videotape and workbook.

Price: \$799; IGES and DXF translators, \$299 each.

Contact: Claris Corp., 440 Clyde Ave., Mountain View, CA 94043, (415) 960-1500. **Inquiry 1119.**

An upgraded VersaCAD also offers two-dimensional construction but goes a

step further than Claris, with three-dimensional viewing, HyperCard stacks, and the ability to operate under Apple's A/UX operating system.

VersaCAD also includes IGES, DXF, and ASCII file translators.

Enhancements to version 2.1 include improved refresh, zoom, and pan operations. Radial and diametral dimensioning of arcs and circles is also added.

VersaCAD's A/UX feature supports the Macintosh Binary Format, providing Unix users with an ability to run Macintosh and A/UX applications with complete file transfer, the company reports.

VersaCAD/Macintosh Edition runs on the Mac Plus, SE, or II with a minimum of 1

megabyte of memory. A math coprocessor is recommended.

Price: \$1995.
Contact: Versacad Corp., 2124 Main St., Huntington Beach, CA 92648, (714) 960-7720.

Inquiry 1120.

Three-Dimensional Solids Modeling

Protocol helps you prepare mechanical designs by letting you see your creation in three dimensions before you construct it. The program verifies all clearances and lets you see all parts. Once you've approved the plan, you can easily draft the technical documentation from the program's model.

Protocol calculates volume, mass, center of gravity, and total or selected wire-frame with hidden line removal or shaded views. The program uses Boolean operations. Other capabilities of Protocol include automatic cross-sectioning with hatching, preparation of exploded views, and presentation of 18 views at the touch of a key.

To run Protocol, you'll need an IBM PC with 512K bytes of RAM (640K bytes for large designs), a hard disk drive with at least 1.5 megabytes, and a CGA, EGA, or Hercules display card. The company recommends an 80286 or 80386 processor.

Price: \$1900.
Contact: CSE Corp., 600 Seco Rd., Monroeville, PA 15146, (412) 856-9200. **Inquiry 1121.**

News Bulletin...

GTEK® has added the **NEW Micro Channel Serial Communications Co-Processor (MCSS-9I)**, with up to **nine channels**, to their line of high-performance communications products. Call Toll Free 1-800-255-GTEK (4835) for more details on this or any of our other development and communications products.



9000 Eprom Programmer

If speed is what you want, GTEK®'s **Model 9000 Eprom Programmer** will never let you down. Its quick pulse and intelligent programming algorithms give you **Super Fast** speed, and you can program the chip of your choice, including MPUs and megabit parts.



9800 Gang Programmer

Ten Times Faster than its predecessor, the **9800 Gang Programmer** has **supersonic** quick pulse programming algorithms. What's more, you'll get your programming completed **8 times faster** by programming 8 eproms at a time. Plus, the 9800 programs megabit parts.

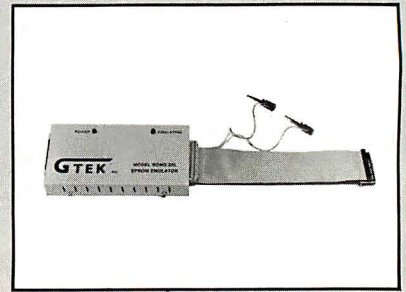

ROMX-2XL Eprom Emulator

GTEK®'s **ROMX-2XL** emulates 2716-27010 eproms and comes with communications software for PC/XT/AT/PS2 type computers. **ROMX-2XL** supports 16 and 32 bit data paths. The time saved on just one development project will more than pay for a **ROMX-2XL!**

ORDER TOLL FREE 1-800-255-GTEK (4835)
FAX: 1-801-487-0935
MS & Technical Support 1-801-487-8048

GTEK® INC.

DEVELOPMENT HARDWARE & SOFTWARE
P. O. Box 2310
Bay St. Louis, MS 39521-2310 U.S.A.

NEW!
Version 2.0

More LaserJet Fonts Than Anybody!

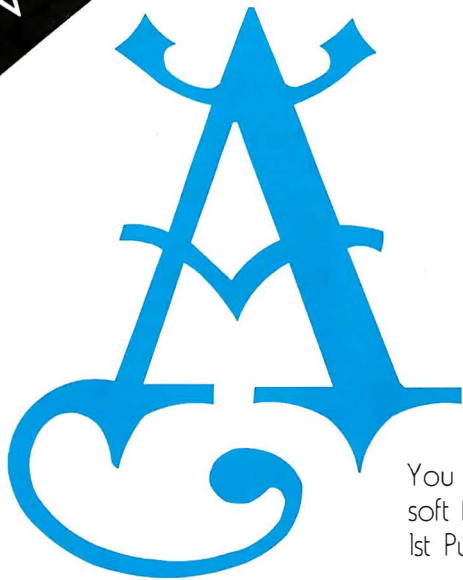

272 Scalable Fonts for HP LaserJet+, II and compatible printers. With *Digi-dui!.. 2.0*, you can quickly and easily make high quality fonts in any size, 3.0-720.0 points, plus slant, expand, rotate, flop, and reverse options. Fill patterns and multiple symbol sets. Make portrait and landscape fonts, with full or partial character sets. **Easy to use!**

You can use DIGI-FONTS with all programs which support soft fonts, including WordPerfect, Ventura, PageMaker, 1st Publisher, WordStar, PCWrite, and MicroSoft Word.

Digi-dui!.. 2.0

Includes 8 DIGI-FONTS, Typeface catalog

\$89.95 + \$3 shipping

Complete Set

Digi-dui!.. 2.0 + 272 DIGI-FONTS

\$439.90 + \$6 shipping

Order Today!
(800) 242-5665

System Requirements

IBM PC/XT/AT or compatible
Hard disk, 5 1/4" floppy
MS-DOS 3.0 or higher
384K RAM Memory
HP LaserJet+, or II or
compatible printer.

DIGI-FONTS, inc.

3000 Youngfield Street, Suite 285
Lakewood, Colorado 80215
(303) 233-8113 FAX (303) 526-9502

VISA, Mastercard, American Express, COD or prepaid orders gladly accepted. Personal checks welcome. Sorry, no billing. Please add \$3 for COD orders. We ship UPS 2nd day delivery unless otherwise requested. We are generally open Monday - Friday, 7 am - 6 pm and Saturdays, 8 am - 3 pm MST. Give us a call, and if we're here, we will be happy to take your order and answer any questions we can. This ad set entirely with DIGI-FONTS' Typefaces. Trademarks are the property of their owners.

le Authoritative (C
ional *Elegant* Trustw
e Reberent Hardwor
Traditional Patrioti
quished *Personal* Honora
nial *Creative* Professio
rtive *Ερθδite* Ope
Fashionable *Regal* Clas
L **Lucky** Artistic PR
ny Modern Organi
cal **Uptown** Antiqu
mentary **Nouveau** Sle
Pretty True **FORMA**
mple Honest **Forth**
thoughtful Exoric **Bu**
gnerian Prudent Se
riendly **Important**
Productive **Efficien**
e Clear **Lively** Suk
ng Suave Proud **H**
Sincere Rich **Funlo**
old Urbane Popular
ent **Intense** Matu
ionist Gentle **Educa**
SSEUR **Gaelic** **Foll**
ealthy Perfectionist
us Permanent **Specb**
y **Different** Sanguin
l Lean Medieval **Forc**
py **Generous** Fastidio
thoritative Honorab
ant **Opulent** Congen
stworthy Open **Perso**
rdworking Distingu
genial *Creative* Profe
sertive *ΓΡΕΕΚ* *Op*
onable *Victorian* Shy
ky **FORMAL** Practica
ssic Updated Typee
town **Practical** O
elle *Elementary* Sle
nny *Feminine* True
gnerian *Friendly* Sex
Productive **Efficien**
e Clear **Lively** Suk

WHAT'S NEW

PACIFIC

Microprocessor Troubleshooting Clinic

Micro Systems Institute is sponsoring a four-day course designed to provide a background in microprocessor fundamentals and troubleshooting techniques for technicians and engineers. Equipment familiarization and hands-on experimentation will be emphasized.

The seminar will cover a background in microprocessor systems and explain TTL and CMOS devices, probes, programming, I/O, memory and memory devices, diagnostic programs, interrupts, emulation, signature analysis, bus systems, digital troubleshooting, test equipment, and logic

analyzers. The seminar will be held June 13 to 16 in Portland, Oregon, at the Red Lion-Jantzen Beach hotel. **Price:** \$845.

Contact: Micro Systems Institute, 73 Institute Rd., Garnett, KS 66032, (913) 898-4695.

Inquiry 926.

Send Us Your Local News

BYTE is expanding its coverage of the Pacific region. If you would like your event, conference, or users group covered, please send information to: Regional Editor, BYTE, One Phoenix Mill Lane, Peterborough, NH 03458. Please take into account a 2½-month lead time.

Two IEEE Conferences on Circuits

The IEEE Custom Integrated Circuits Conference will be held at the Town & Country Hotel in San Diego, California, May 15 to 18. Scheduled sessions include programmable devices, data converters, mixed analog/digital applications, highly parallel architecture and neural nets, and telecommunications circuits, to name a few.

Price: Before May 1: \$125 for IEEE members, \$155 for nonmembers; after May 1: \$160 for members, \$190 for nonmembers.

Contact: Technical Program Coordinator CICC '89, 1597 Ridge Rd. W, Suite 101C,

Rochester, NY 14615, (716) 865-7164.

Inquiry 931.

The 1989 IEEE International Symposium on Circuits and Systems will be held May 9 to 11 at the Portland Hilton in Portland. Topics of sessions include CAD, VLSI design, fault analysis, high-speed circuits, circuits and systems theory, analog signal processing, linear and nonlinear digital filters, large-scale networks, multidimensional signal processing, and many others.

Price: \$240 for members; \$280 for nonmembers.

Contact: Gail Floyd, P.O. Box 500, M.S. 50-370, Beaverton, OR 97077, (503) 627-6107.

Inquiry 932.

continued

AutoKey 400 programmable macro keys!

Simplify DOS, D-base, Lotus 1-2-3.
Boost your CAD performance.
Automate word processing.

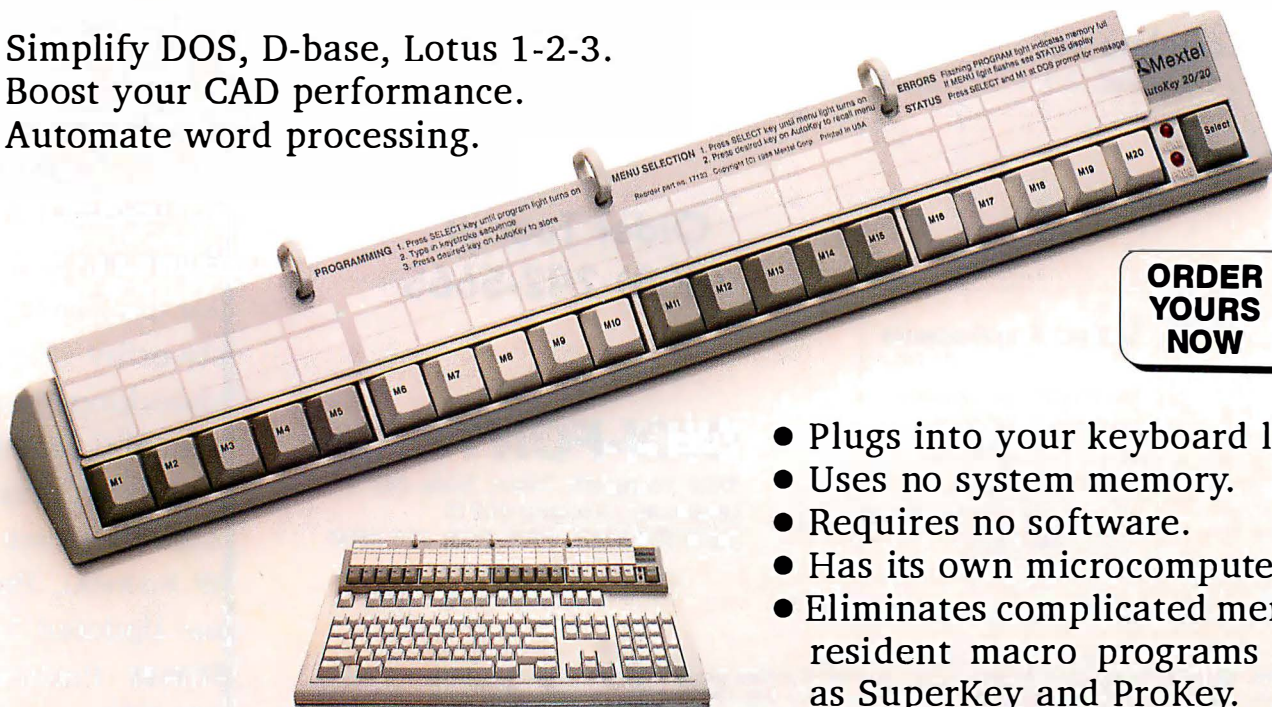

**ORDER
YOURS
NOW**

- Plugs into your keyboard line.
- Uses no system memory.
- Requires no software.
- Has its own microcomputer.
- Eliminates complicated memory resident macro programs such as SuperKey and ProKey.

Mextel Corp. 159 Beeline Road
Bensenville, Illinois 60106

AutoKey is trademark of Mextel Corp. All other product names are trademarks of their respective manufacturers. ©1989 MEXTEL CORP.

Call 1-800-888-4146
(inside IL call 312-595-4146)

AutoKey 40 \$139.00
AutoKey 20/20 \$289.00

Visa/MC/AmEx.

FINALLY, ONE DISC DRIVE SOURCE

HARD DRIVES

ST506 Interface - 3 1/2" Hlf. Ht.

| | | |
|------------------|-----------|--------|
| Seagate ST125 | 20mb/28ms | \$ 249 |
| Seagate ST138 | 30mb/28ms | 299 |
| Mitsubishi MR535 | 42mb/22ms | 525 |
| Toshiba MK134FA | 42mb/25ms | 495 |

ST506 Interface - 5 1/4" Hlf. Ht.

| | | |
|-----------------|-----------|--------|
| Seagate ST225 | 20mb/65ms | \$ 225 |
| Seagate ST238 | 30mb/65ms | 249 |
| Miniscribe 3650 | 40mb/65ms | 349 |
| Seagate ST251 | 42mb/40ms | 355 |
| Seagate ST251-1 | 40mb/28ms | 445 |
| Seagate ST277R | 65mb/40ms | 445 |

ST506 Interface - 5 1/4" Full Ht.

| | | |
|-------------------|------------|--------|
| Micropolis 1325 | 72mb/28ms | \$ 695 |
| Seagate ST4096 | 80mb/28ms | 599 |
| Maxtor XT1140 | 120mb/28ms | 1,625 |
| Newbury Data 1140 | 120mb/25ms | 1,395 |
| Maxtor XT2190 | 150mb/28ms | 1,895 |

SCSI Interface - 5 1/4" Full Ht.

| | | |
|--------------------|------------|---------|
| Newbury Data 3170S | 147mb/19ms | \$1,595 |
| Maxtor XT3280S | 244mb/16ms | 1,895 |
| Siemens 2300 | 310mb/16ms | 2,295 |
| Newbury Data 3380S | 320mb/19ms | 2,495 |
| Maxtor 4380S | 320mb/16ms | 2,795 |
| Siemens 4420 | 383mb/16ms | 2,495 |
| Maxtor XT8760S | 660mb/16ms | 5,195 |

ESDI Interface - 5 1/4" Full Ht.

| | | |
|--------------------|------------|---------|
| Newbury Data 4175E | 147mb/19ms | \$1,495 |
| Siemens 1300 | 310mb/25ms | 2,295 |
| Newbury Data 4380E | 320mb/19ms | 2,295 |
| Maxtor XT4380E | 320mb/16ms | 2,795 |
| Siemens 4410 | 383mb/16ms | 2,495 |
| Maxtor XT8760E | 660mb/16ms | 4,995 |

**1 YR. WARRANTY
ON ALL PRODUCTS
EXCEPT AS NOTED.**

FLOPPY DRIVES

3 1/2" Hlf. Ht.

| | | |
|---------|--------|--------|
| Teac | 720k | \$ 110 |
| Fujitsu | 720k | 105 |
| Teac | 1.44mb | 120 |
| Fujitsu | 1.44mb | 115 |

5 1/4" Hlf. Ht.

| | | |
|--------------|-------|-------|
| YE-Data | 360k | \$ 69 |
| Alps IBM | 360k | 69 |
| Teac FD55BR | 360k | 79 |
| Fujitsu | 360k | 75 |
| Teac FD55GFR | 1.2mb | 115 |
| Fujitsu | 1.2mb | 110 |

TAPE DRIVES

TANDBERG 1/4" Tape Drives

| | | |
|-----------|--------------|--------|
| Mdl. 3620 | 60mb/SCSI | \$ 645 |
| Mdl. 3610 | 60mb/QIC-02 | 645 |
| Mdl. 3640 | 125mb/SCSI | 795 |
| Mdl. 3630 | 125mb/QIC-02 | 795 |
| Mdl. 3660 | 150mb/SCSI | 895 |
| Mdl. 3650 | 150mb/QIC-02 | 895 |

IBM PS/2 KITS

| | |
|-----------------------------|--------|
| 360k Floppy w/Case & Cable | \$ 210 |
| 1.2mb Floppy w/Case & Cable | 250 |

CONTROLLERS

| | |
|--|-------|
| Mini Micro Floppy, 1.2mb | \$ 69 |
| "Big" Floppy, 360k | 59 |
| WD1002-WX1 Tandy | 99 |
| WD-WXT-GEN | 79 |
| WD1003-WA2 AT | 149 |
| ADAPTEC 2072A XT RLL | 99 |
| XEBEC 1210, XT, 10-20mb only | 59 |
| DTC 5287, AT RLL | 195 |
| Perstor 200 Series, AT (8 Bit) | 225 |
| Perstor/Sequel SQ6180F, AT (16 Bit) | 325 |
| LCS 6620, 16MHz, AT | 149 |
| Data Master 44-800 - 3 1/2", 5 1/4", 8" Floppy | 79 |
| SCSI Controller, Future Domain TMC841 (Kit) | 350 |
| Omti 8620, ESDI Controller | 295 |
| WD1007-WA2, ESDI, AT (HD & FI) | 325 |
| WD1007-WAH, ESDI, AT (HD) | 315 |

CABLES

| | |
|--------------|-------|
| XT Cable Set | \$ 15 |
| AT Cable Set | 15 |

DRIVE CASES

| | |
|--------------------------------|--------|
| Hard Drive with Power Supply | \$ 165 |
| Floppy Drive with Power Supply | 99 |

- Thousands of disc drives in stock, call or write for brochure.

SPECIAL KITS FOR IBM AT & COMPATIBLES

Formatted capacity

| | |
|--------------|--------|
| 84mb - ST506 | \$ 695 |
| 175mb - ESDI | 1,395 |
| 230mb - ESDI | 1,695 |
| 320mb - ESDI | 1,995 |

**KIT INCLUDES:
DISC DRIVE
CONTROLLER
SOFTWARE
INSTRUCTIONS**

- 90 DAY WARRANTY, LIMITED QUANTITIES

HARD DRIVE REPAIR SPECIAL

SPECIAL REPAIR DISCOUNT COUPON

90 day Warranty on all repairs.

Ampex, Atasi, CDC, CMI, Fujitsu, Hitachi, IBM, Maxtor, Micropolis, Microscience, Miniscribe, NEC, Quantum, Lapine, Priam, Rodime, Seagate, Shugart, Tandon, Titan, Tulin, Toshiba, Newbury Data and most other brands.

**FLOPPY DRIVE REPAIRS
5 1/4" ... FLAT RATE \$45**

HARD DRIVES

Capacity Flat Rate SPECIAL

| | | |
|-------------------|-------|-----------------|
| 10-19mb | \$99 | \$89.10 |
| 20-30mb | \$125 | \$112.50 |
| 31-40mb | \$150 | \$135.00 |
| 41-49mb | \$175 | \$157.50 |
| 50-85mb | \$210 | \$189.00 |
| 86-120mb | \$275 | \$247.50 |
| 121-150mb | \$325 | \$292.50 |
| Test & Evaluation | \$25 | |

SHIPPING YOUR DRIVE FOR REPAIR

Pack your drive carefully and well protected in a sturdy shipping box. Include with the shipment a note with your name, address, daytime telephone number and a brief description of the problem with the drive.

jb TECHNOLOGIES, INC.
21011 Itasca St. - #F
Chatsworth, CA 91311
Telephone (818) 709-6400

COUPON MUST BE SENT WITH DRIVE

VALID THROUGH MAY 31, 1989

jb TECHNOLOGIES, INC.

21011 Itasca St., #F
Chatsworth, CA 91311

Circle 536 on Reader Service Card

Telephone: (818) 709-6400

Telex: 678953

FAX: (818) 341-2935

- Corporate, Government and School POs welcomed.
- Visa or Mastercard welcomed.
- COD, Cashier's Check or Money Order.
- Personal Check - Shipment after Clearance.
- California residents must add applicable sales tax.
- All prices subject to change without notice.

MAY 1989 • B Y T E 96PC-3

Report Helps Users Groups Gain Tax-Exempt Status

Although the benefits for a users group are numerous, gaining tax-exempt status involves considerable time, effort, and, quite possibly, a lot of hair and teeth pulling—the process can be complicated and time-consuming. Users groups will do well to use the services of an attorney or accountant from the start: A nonprofit organization does not by definition automatically qualify for tax-exempt status, and your group may need to submit additional information beyond that of your original application.

Although most users groups opt for the 501 (c) (3)

educational route, a group can also qualify as a social club, civic league, or other classification. Gaining 501 (c) (3) status has the most advantages for the typical users group, but it also carries the highest number of restrictions.

If you want to form a tax-exempt users group or convert to that status but don't know where to begin, the Apple Computer User Group Connection will provide to any users group a 60-page report that will show you how. Prepared by Thomas Warrick, a lawyer and former president of Washington Apple Pi, the report covers why a users group should consider becoming tax-exempt, the advantages and disadvantages of each classification, and steps to take in the application process.

Contact: Apple Computer,

Inc., User Group Connection, 20525 Mariani Ave., Cupertino, CA 95014, (408) 974-6343.

Optical Storage Forum in San Jose

The fourth international Optical Storage Forum will convene May 9 to 11 at the Fairmont Hotel in San Jose. The forum will focus on the actions required by optical storage companies to make the transition from a promising technology to a major growth industry.

Price: \$995.

Contact: Cartlidge & Associates, Inc., 3097 Moorpark Ave., Suite 202, San Jose, CA 95128, (408) 554-6644.

Inquiry 927.

MUMPS Users Group Annual Meeting

Everything from introductory tutorials on the MUMPS (for Massachusetts General Hospital Utility Multi-programming System) language to writing MUMPS applications will be featured at the eighteenth annual meeting for users of the language. The conference will be held in Seattle May 15 to 19 at the Washington State Convention and Trade Center.

Price: Full registration, \$275; one day only, \$170.

Contact: MUMPS Users' Group, 4321 Hartwick Rd., Suite 100, College Park, MD 20740, (301) 779-6555.

Inquiry 929.

WE ARE THE LOW PRICED LAN EXPERTS

MICRO UNIVERSE™

"Lowest Prices in the Universe"

WORDPERFECT VER. 5.0 218.00 LAN VER. 326.00

(800) 441-4LAN National Order Line • (213) 316-6598 In California

SYSTEM

| | |
|----------------------------|---------------|
| ACERSTATION | \$ 982 |
| ACER900-2MB | \$1668 |
| ACER910 | \$1198 |
| ACER915 | \$1161 |
| ACER1100/16MHz | \$2472 |
| AST Model 80 | \$1470 |
| AST Model 300 | \$2688 |

LAPTOPS

| | |
|--------------------------|--------|
| Toshiba 1000 | \$ 795 |
| Toshiba 1200 | \$1409 |
| Zenith Super Sport | \$3630 |
| Mitsubishi | |
| MP286L | \$2430 |

PRINTERS

| | |
|------------------------|---------------|
| HP LaserJet | \$1595 |
| Panasonic | |
| 1191i NEW | \$ 232 |
| Laser Partner | \$1496 |
| NEC | |
| P5200 | \$ 509 |
| LC890 | \$3160 |
| Toshiba | |
| P351SX | \$ 970 |
| P321SL | \$ 487 |

LAN PRODUCTS

| | |
|---|------------|
| Novell Complete 2-Users Turnkey Network | |
| Installed & Configured \$2,300 | |
| Novell ELS I | \$385.00 |
| 4 Port Passive Hub | \$19.95 |
| Arcnet Card | \$96.00 |
| BNC Connectors | \$1.85/ea. |
| BNC "T" Connectors | \$2.95/ea. |
| Complete 2 User Kit ... \$580.00 | |
| Novell Complete 4-Users Turnkey Network | |
| Installed & Configured \$4,399 | |
| Novell ELS II | \$ 843.00 |
| Novell Netware 2-15 | \$1778.00 |
| 4 port Active Hub | \$ 98.00 |
| 8 Port Active Hub | \$ 251.00 |
| Ethernet Card | \$ 185.00 |
| Cabling (RG-58) | .12¢/ft. |
| 4 User Kit | \$1150.00 |
| Call for Other Novell Turnkey LAN Packages! | |

TAPE DRIVE

| | |
|---------------------|--------|
| Archive 150MB | \$ 825 |
| Mountain 150 | \$1526 |

SOFTWARE

| | |
|------------------------------|--------------|
| WordPerfect 5.0 | \$218 |
| WordPerfect 5.0 (LAN) | \$326 |
| Lotus 123 | \$288 |
| R: Base for DOS | \$488 |
| R: Base for DOS (LAN) | \$662 |
| Pagemaker 3.0 | \$486 |
| DBaseIII+ | \$415 |
| DBaseIII+ (LAN Pack) | \$620 |
| MicroSoft Word | \$209 |
| MicroSoft Window2.1 | \$ 62 |
| PC Excel | \$225 |
| Flight Simulator | \$ 29 |
| Sprint | \$124 |
| WordStar 5.0 | \$229 |

BOARDS

| | |
|--------------------------|-------|
| Intel 386/PC | \$641 |
| Intel Above Board+ | \$421 |
| AST Six Pak Plus | \$274 |
| IRMA II | \$697 |
| ATI EGA Wonder | \$221 |
| Everex EGA | \$162 |
| Paradise VGA+ | \$258 |

MODEMS

| | |
|-------------------|-------|
| Hayes 2400B | \$400 |
| Hayes 1200B | \$250 |

UPS

| | |
|-----------------------|-------|
| DataShield 800W | \$656 |
|-----------------------|-------|

MISC.

Ribbons Best Price!
 Microsoft Mouse \$111 || MasterPiece + | \$109 |
| CoProcessor 287/10 | \$245 |
| Ribbons | Best Price! |
| **Laplank Plus** | **\$ 83** |
| Fastback Plus | \$101 |
| Prices are subject to change without notice & reflect cash discounts. We accept most major credit cards, personal/company checks. Corporate accounts welcome. On-site Network installation & training available. Ask about our RENT-A-LAN Program. Shipping + 3% handling. In California & International Orders: **(213) 316-6598** Technical Assistance Line: **(213) 316-4008** **(213) 470-0788** | |

CALL FOR ITEMS NOT LISTED

MAGIC PC™: It used to be a secret...

The Story Behind dBASE

Not Anymore!

Thousands of top Professional and Corporate DBMS developers revealed to **PCWEEK**¹ the secret to their success: Magic PC – The Visual Database Language.

Surprised? We're not. We knew all along that database pro's, consultants and VARs guard Magic PC as a valuable trade secret. No wonder. It gives them a superior competitive edge: powerful applications 10-20 times faster than any DBMS or 4GL.

More interesting is how the respondents placed a lesser-known package, Aker Corp.'s Magic PC, in the top grouping and relegated a very well-known package, Ashton-Tate's dBASE III Plus, to eighth place.

| Line | Item | Type | Description | Quantity | Unit Price | Total Price | | | | | | | | |
|--|----------------------|------|----------------------|----------------|-------------|-------------|-----|-------------|------|-------|-----|----------------------|---|----------|
| 999 | 99999 | A | AAAAAAAAAAAAAAAAAAAA | -9.999 | -999.999.99 | -999.999.99 | | | | | | | | |
| <table border="1"> <thead> <tr> <th>No.</th> <th>Description</th> <th>Type</th> <th>Price</th> </tr> </thead> <tbody> <tr> <td>999</td> <td>AAAAAAAAAAAAAAAAAAAA</td> <td>A</td> <td>-999.999</td> </tr> </tbody> </table> | | | | | | | No. | Description | Type | Price | 999 | AAAAAAAAAAAAAAAAAAAA | A | -999.999 |
| No. | Description | Type | Price | | | | | | | | | | | |
| 999 | AAAAAAAAAAAAAAAAAAAA | A | -999.999 | | | | | | | | | | | |
| | | | | Order Sum | | -999.999.99 | | | | | | | | |
| | | | | Discount | | -999.999.99 | | | | | | | | |
| | | | | Sub-Total | | -999.999.99 | | | | | | | | |
| | | | | Sales Tax | | -999.999.99 | | | | | | | | |
| | | | | Order Total | | -999.999.99 | | | | | | | | |
| | | | | In Stock: | | -999.999 | | | | | | | | |
| | | | | Total Orders: | | -999.999 | | | | | | | | |
| | | | | Avail to Sell: | | -999.999 | | | | | | | | |

PC TECH Journal concurs:

"Magic PC's database engine delivers powerful applications in a fraction of the time... there is no competitive product."

State-of-the-art Features

Automatic non-procedural processing

Event-driven execution control

Multi-User RDBMS

Quick Prototyping

Multi-file zoom lookups

Easy-to-use user interface

Built-in visual query-by-example

Proven BTRIEVE® Performance

Magic PC is based on Novell's Btrieve® for maximum performance and reliability. And if you already program with Btrieve®, use Magic PC to create instant customizations of your existing applications with full file compatibility, beyond Xtrieve® and Rtrieve®.

International inquiries call **M.S.E. Ltd.**
(972) 3 751-4195 FAX: (972) 3 751-6218

Goodbye 4GLs

Magic PC's revolutionary power and programming speed obsoletes conventional database languages, just like CAD obsoletes manual drafting. Magic PC frees you from the entire coding and maintenance responsibility, so you can concentrate on your system design.

You specify dictionaries, processing flow scheme and drawings of screens, reports, windows, menus, etc. Design changes are easily applied on the fly and automatically maintained. Your design is immediately executed by Magic PC's stand-alone runtime engine.

You finish even before conventional DBMS programmers normally begin the coding phase. Imagine saving all those months of tedious trial-and-error coding, debugging, testing and re-coding.

30 Day Money Back Guarantee

Discover the secret to professional DBMS success. Order your copy of Magic PC now without any risk! Magic PC single user \$299, Magic LAN multi-user \$699². But, if you'd rather spend your time coding — simply return in 30 days and we'll refund you promptly less \$19.95 restocking, no questions asked.

Dealers Welcome

800-345-6244

In CA 714-250-1718

Fax: 714-955-0199

AKER

19782 MacArthur Bl. Suite 305, Irvine, CA 92715

¹ PC WEEK, Jan. 16 '89

² Add \$10 P&H. tax in CA. Requires IBM/100% comp. 512K hard disk, DOS 3.1 or later. Includes Btrieve runtime. 5.25" not copy protected. © Copyright Aker, 1989. Btrieve®, Xtrieve®, Rtrieve® are trademarks of Novell.

PC WEEK

PC WEEK REVIEWS POLL

Four DBMS Contenders Awarded Top Honors By Respondents

75 Magic PC Ver. 2.5
Aker Corp.
Tied for tops in Programming Languages and Report Flexibility

75 Paradox ver. 2.0
Borland International
Shared highest ratings in Report Flexibility and Documentation

75 FoxBase Plus Ver. 2.1
Fox Software
Awarded top honors in Support features and Performance

75 dBase III Plus Ver. 1.2
WardTech Systems
Rated tops in Ease of Programmability

72 VP-Info Ver. 1.4
Paperback Software
Rated the highest in Value Relative to Cost, Installation

71 R:base for DOS
Micromim
Solid showing with above-average scores in all but one attribute

70 Advanced Revelation Ver. 1.2
Revelation Technologies
Respectable showing with six above-average scores

69 DataEase Ver. 2.53
DataEase
Solid showing; below average score in Programming Language

68 The Smart Database Ver. 3.1
Informix Software
Below-average scores in eight features, including Performance

66 Condor 3 Ver. 2.20
Condor Computer
Tied for tops in Documentation Clarity, lowest in Reporting

65 dBASE III Plus Ver. 1.1
Ashton-Tate
Nine below-average scores; above average in Documentation

64 PC/Focus Ver. 3.0
Information Builders
Lowest in Relative Value; shared tops in Report Flexibility

63 Professional Oracle Ver. 5.1A
Oracle Corp.
Decent showing. Average scores, but lowest in Installation

62 Omnis Quartz Ver. 1.13
Blyth Software
Rated lowest in Performance, Ease of Programmability

62 DataFlex Ver. 2.3
Data Access Corp.
Bottom scores in Documentation Clarity, Vendor Support features

61 KnowledgeMan/2 Ver. 2.5
Micro Data Base Systems
Rated lowest in Power of User Interface and Ease of Use

“As an industry leader, we can offer you an opportunity that’s as unique as you are.”



KAISER PERMANENTE

Good People. Good Medicine.

- Are you as comfortable with a circuit board as with a COBOL manual?
- Can you handle the responsibility for a project from beginning to end?
- Can you specify, design, program and train users on a computer system?

Our Technology Evaluation and Support Department is looking for talented, creative individuals to help this major health care provider in Southern California explore the future. Selected candidates will have 5 years experience in data processing, including electronics, programming and

analysis. Must have the ability to work on small, innovative computers, robotics and other technology related projects involving BASIC, FORTRAN, COBOL, “C” and multiple database languages on multiple machines, such as IBM mainframe, CP/M, MacIntosh or UNIX-type microcomputers.

For consideration, please submit resume with salary history to: **Kaiser Permanente, Dept. 9095/RH/JOU-102-5/89, 393 E. Walnut Street, Pasadena, CA 91188-5080.** Equal Opportunity Employer.



FOUR GUYS COMPUTERS IN HOUSE SERVICE & SUPPORT

“INVADING THE COMPUTER WORLD”
136 WEST 32ND ST. (BTWN. 6-7 AVES.), NEW YORK, NY 10001

FREE GIFT
w/Every Order

OPEN 7 DAYS
MON-SAT 10-8
SUN 10-6

CORPORATE ACCOUNTS WELCOME

PHONE ORDERS ACCEPTED
IN NYS (212) 643-3900
ON SAT (212) 239-4350

1-800-242-4GUY

CALL & ASK US TO BEAT YOUR BEST PRICE

IF YOU DON'T SEE WHAT YOU WANT, ASK FOR IT.

COMPAQ DESKPRO 286
12 MHz • 1.2 Floppy Drive • 40 MB H.D. **\$1975**

COMPAQ DESKPRO
386S VGA
40 MEG H.D. **\$3249**

HYUNDAI 286C 640K
30 Meg Hard Drive & More!
18 Month Warranty **\$1199**

SANYO 286 AT COMP.
1 MEG on MB - 1.2 Floppy DOS Included **\$1199**

NEW AST 286
AT Compatible 512K **\$999** IN STOCK ON SALE!

AST **\$1629**
AST PREMIUM 286
10 MHz • 512K • 1.2 Floppy Seagate 40 MB H.D.

FOUNTAIN TECH 386/16
1 Meg RAM 1.2 Floppy 101 Keyboard **\$1699**

FOUNTAIN TECH FAST 12 MHz
100% IBM Compatible • 286/12
1.2 Floppy DOS and BASIC
101E Keyboard **\$899**

AMIGA
All Commodore Amiga products in stock — Greatly Discounted. Call & Will Beat Any Price.

APPLE COMPUTERS
Apple IIGS
Apple IIC Plus
Macintosh SE
MAC II **IN STOCK**
MAC SE 30 NEW
MAC Plus
Image Writer II
Apple Laser Writer

Commodore Colt XT Compatible
2 Floppies w/CGP/MGP and monitor **\$749**

PACKARD BELL XT
2 Floppies MGP/CGP mono monitor **\$799**

ACTION PRINTERS
BY EPSON ALL IN STOCK

LAPTOP COMPUTERS
TOSHIBA T-1200 IN STOCK
TOSHIBA T-1200 FB CALL
TOSHIBA T-1200 HB CALL
TOSHIBA 1600 CALL
TOSHIBA A3200 CALL
TOSHIBA 5100 CALL
TOSHIBA 5200 CALL
ZENITH 184-1 (2 drives) CALL
ZENITH 184-20 CALL
ZENITH SUPERSPORT 286 CALL
ZENITH SUPERSPORT 386/40 IN STOCK CALL
NEC MULTISPEED HD CALL
MITSUBISHI 286 CALL
NEC ULTRALITE CALL

Panasonic
Office Automation
2 Year Warranty on all Panasonic Printers
Pan. KXP1180 \$179.00
Pan. KXP1191 \$239.00
Pan. KXP1124 IN STOCK
Pan. KXP1524 \$519.95
Pan. KXP1592 \$379.95
Pan. KXP1595 \$429.95
Brother HL8 \$1799.00
HP Laserjet II \$1595
Panasonic Laser \$1399.90

ALL PRINTER PRICES VALID ONLY WITH PURCHASE OF CABLE

MONTHLY SPECIALS
Ext. PC Comp. 1200
Modem \$99.00
Citizen MSP10 \$229.00
Diconix 150 \$299.00
FASTRAX BY BRIDGEWAY \$49.95
Hewlett Packard Desk Jet \$679.00

COMPLETE PC ANSWERING MACHINE ALL IN STOCK
FAX CARD 2400
FAX CARD 9600
SCANNER

brother Authorized Dealer
Brother 1509 In Stock
Brother 1709 \$339.00
Brother 1109 In Stock
Brother HR-20 \$339.00
Brother HR-40 \$529.00
Brother Twinwriter In Stock

MODEMS MICE
Prometheus Genius \$39.95
US Robotics Logitech
Hayes Microsoft
Practical Peripherals ALL IN STOCK
Novation

FAX MACHINES
Scanners CALL

ALL OUR PRODUCTS ARE FACTORY FRESH WITH FULL WARRANTY. NOT RESPONSIBLE FOR TYPO ERRORS. ALL PRICES IN THIS AD CASH ONLY. 10 DAY RETURN WITH ALL ORIGINAL PACKAGING AND RETURN AUTHORIZATION. SHIPPING AND HANDLING EXTRA. THIS AD SUPERCEDES ALL OTHER ADS. PRICES AND AVAILABILITY SUBJECT TO CHANGE WITHOUT NOTICE. DEPARTMENT OF CONSUMER AFFAIRS #800105 #05694



Finally ... a professional menu system in a *graphics* environment for Turbo-C, Microsoft-C, Turbo-Pascal: **graphics-MENU™**

ONLY \$149 (TP) SOURCE AVAILABLE
works with MetaGraphics MetaWindow

graphics-MENU from Island Systems is a comprehensive utilities package that allows the developer of graphics applications to quickly create a user friendly interface. You can spend more time focussing on the internals of your application.

- Mouse Handling.
- Keyboard support for most menu types.
- Pulldown Menu & Popup messages.
- Underlying graphics automatically saved.
- Button menus in any arrangement.
- Mouse can drag menus & messages to reveal image beneath.

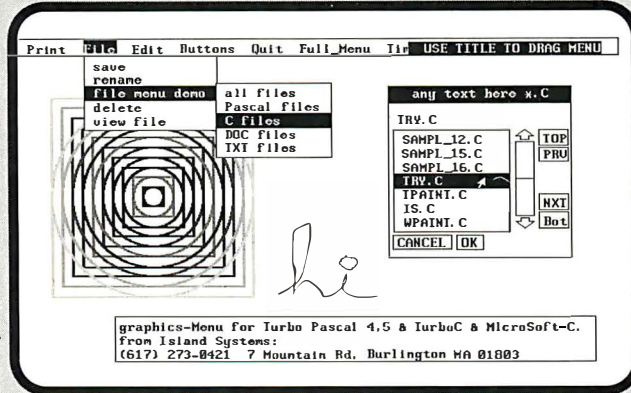

graphics-Menu for Turbo Pascal 4.5 & TurboC & MicroSoft-C.
From Island Systems:
(617) 273-0421 7 Mountain Rd. Burlington MA 01803

We are also including two utility programs: **CurEdit** and **MenuDesigner**. CurEdit is a Cursor icon Editor that enables you to create custom cursor icons and associate them with any mouse button or chord. MenuDesigner is a powerful utility that enables you to create and view complex horizontal & vertical menu structures *on-screen* and then writes C or Pascal to implement this structure in your application.

Requires: MetaWindow® (MetaGraphics Software Corp). IBM with graphics & mouse (suggested). 30 day money-back guarantee on non-source.

graphics-MENU
TP 4 or 5 \$149
with source . . . \$224
TC or MS-C . . . \$195
with source . . . \$295
MetaWindow®
TP or TC \$95
TP & TC & MS-C \$195

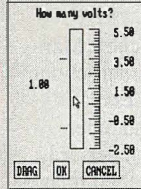

- Vertical list optionally titled.
- Horizontal list with corresponding pulldown menus that may have nested sub-menus to any depth.
- Popup message boxes with or without user prompt.
- Controls & gauges with analog style entry.

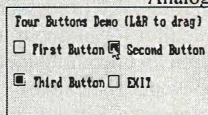
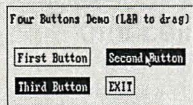

- Limitless hybrids of the above menus for customization.
- Geometric interface functions: point rotation, distance, degrees / radians conversion, true 4-quadrant arctan.
- Analog clock settable by moving its hands with the mouse.

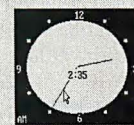

Island Systems
7 Mountain Rd. Burlington MA 01803
CALL
(617) 273-0421



BYTE & FLOPPY COMPUTERS



Intel Inboard 386..... \$695
For your IBM PC/XT and Compaq Portables



- 16MHz 80386 Runs Up to 10 Times Faster Than an IBM PC/XT Alone
- 1 MB of Memory
- Compatible with all Major Application Programs — 1-2-3, AutoCAD, dBASEIII, Word, and Many Others

Intel Above Board Plus I/O
with 512K Expandable to 8MB
Parallel & Serial Ports

Also Works with PS2 Model 30 **\$495**

Intel Above Board Plus
with 512K RAM Expandable to 8MB

Also works with PS2 Model 30 **\$435**

Intel Math Processors

| | |
|----------------------|------|
| 8087 (5 MHz)..... | \$95 |
| 8087-2 (8 MHz)..... | 135 |
| 8087-1 (10 MHz)..... | 190 |
| 80287 (6 MHz)..... | 150 |
| 80287-8 (8 MHz)..... | 225 |
| 80287 (10 MHz)..... | 255 |
| 80387 (16 MHz)..... | 380 |
| 80387 (20 MHz)..... | 450 |
| 80387 (25 MHz)..... | 575 |

AST Xformer/286

Replace Your IBMXT MOTHER-BOARD with AST Xformer/286. **\$490**
Limited Stock

PACIFIC

DATA PRODUCTS

Plotter in a Cartridge

HPGL Emulation for Laser Printers



Plotter Emulation for HP LaserJet SeriesII in a Cartridge **\$325**

We Will Ship Today All Advertised Items in Stock



4770 Ruffner Street
San Diego, CA 92111

(619) 571-9013

BYTE & FLOPPY COMPUTERS

FAX (619) 571-9083

We are not responsible for topographical errors.

No Extra Charge for VISA or M. C.

C.O.D Cashiers Check Only

Free Shipping By U.P.S

For Air Shipment Add \$5 Per Item

CD-ROM with over 15,000 Programs

PC-SIG has started shipping the sixth edition of its PC-SIG Library on CD-ROM. The new disk contains the equivalent of 1240 disks, with more than 15,000 programs.

PC-SIG reports that the disk's directory, which contains program descriptions and file listings for every program on the disk, is over 3 megabytes long. To help you search for a program by title, disk number, filename, or key word, the company included the WordCruncher text retrieval system from Electronic Text Corp. PC-SIG also included a Copy-Access program to automate the process of going to a program on the CD-ROM and copying all the program's files to another disk.

All the programs on the disk are shareware or public domain. The disk works with any Hi Sierra-format CD-ROM player.

Price: \$495.
Contact: PC-SIG, 1030-D East Duane Ave., Sunnyvale, CA 94086, (408) 730-9291.
Inquiry 906.

DEC Text-Processing Utility Emulation

Designed for experienced users of Digital Equipment Corp.'s Text Processing Utility (TPU), nu/TPU lets you define its interface to work in the same way you're used to working in the VAX/VMS, Unix, or DOS environment.

a/Soft developed the text editor as a full implementation of DEC's TPU with features that include multiple windows and buffering, definable interfaces, 92 built-in editing procedures, flexible key-

board mapping, EDT and EVE editing keypads, automated error recovery, and a high-level procedural language.

EVE, EDT, VI, and Word-Star interfaces are included with the product: you can modify the interfaces or use nu/TPU to build your own editing interface.

In the DOS environment, nu/TPU works on the IBM PC and compatibles with DOS 3.0 or higher and requires 300K bytes of RAM.

Price: DOS version, \$325; Unix-based versions, between \$395 and \$2500.

Contact: a/Soft Development, Inc., 1353 Salem St., North Andover, MA 01845, (508) 683-4369.

Inquiry 900.

PixelPaint 2.0 Features Pantone, Dithering

PixelPaint, the 8-bit color paint program that helped establish the Mac II as a machine for engineering and graphics arts, now features Pantone color-matching capabilities. The program's developer, SuperMac, reports it has solved the "banding" problem sometimes evident in 8-bit color paint products.

The PixelPaint 2.0 toolbox has also been enhanced with masking tools to create air-brush effects, smoothing, blending, and dithering techniques for the application of color.

PixelPaint 2.0 reads and writes files stored in MacPaint, PICT, PICT2, EPS, and black-and-white TIFF file formats. The program supports QuickDraw and PostScript output devices, including digital typesetting and color-separation equipment.

The recommended mini-

mum requirement is a Mac II or SE/30 with 2 megabytes of memory, a hard disk drive, an 8-bit graphics card, System 6.0 or higher, and a color or gray-scale display.

Price: \$395.

Contact: SuperMac Technology, 485 Potrero Ave., Sunnyvale, CA 94086, (408) 245-2202.

Inquiry 904.

Scheduler Links to Word Processor for Detailed Info

PCCAL is a scheduling utility that you can link to your word processor or text editor for in-depth information on an upcoming meeting or event. You can use the program to schedule individuals by themselves or in groups, thereby avoiding scheduling conflicts when you need to schedule a workgroup meeting. If a conflict occurs, the program tells you and helps find an open slot.

You can display several schedules side-by-side on screen, and you can view a list of those attendees by requesting appointment detail.

PCCAL's three-week display allows for canceling and moving appointments and the automatic scheduling of repeat appointments. Category assignments let you include only those for meetings pertinent to their job responsibilities.

The program runs on the IBM PC or compatibles with DOS 3.1 or higher and 256K bytes of RAM. Other versions of the program can run on SCO Xenix systems, PC networks, and the HP3000.

Price: PCCAL for PCs, \$95; SCO Xenix version, \$395; HP3000 version, \$795; PC Network version, \$795.

Contact: Bradford Business Systems, 25301 Cabot Rd., Suite 201, Laguna Hills, CA 92653, (714) 859-4428.

Inquiry 1199.

Four Connectivity Products for the Mac

One difference between the Mac SE/30 and the Mac SE is that the 030 Direct Slot's 120-pin Euro-DIN connector isn't compatible with the 96-pin Mac SE expansion slots. The MaraThon 120/96 Bus Adapter card, one of six new Dove Computer Corp. products, allows expansion cards designed for the original Mac SE to function on the SE/30.

The company's new MaraThon Scanner Card allows a Mac II user to access Canon's IX-12 and other similar scanners. The card lets you move scanned images into the Mac II to use with graphics, optical character recognition, and page layout programs with NuBus speed and performance, the company reports.

The MaraThon 030X is a 32-MHz accelerator card for the Mac IIx. Dove reports an average of 25 percent performance increase, up to 40 percent in processor-intensive tasks. Similarly, the MaraThon 030/SE is a 32-MHz accelerator card for the Mac SE, which Dove reports will double the machine's performance. It can accommodate up to 4 megabytes of on-board RAM, and it fits in the SE expansion slot.

Price: MaraThon 120/96 Bus Adapter, \$199; MaraThon Scanner Card, \$199; MaraThon 030X, \$1599; MaraThon 030/SE, \$1999.

Price: Dove Computer Corp., 1200 North 23rd St., Wilmington, NC 28405, (800) 622-7627; in North Carolina, (919) 763-7918.

Inquiry 903.

SHORT TAKES

BYTE editors' hands-on views of new products

Magellan

Virtual

Compaq Fixed Disk
Drive Expansion Unit

MultiBoot

Disk Technician
Advanced

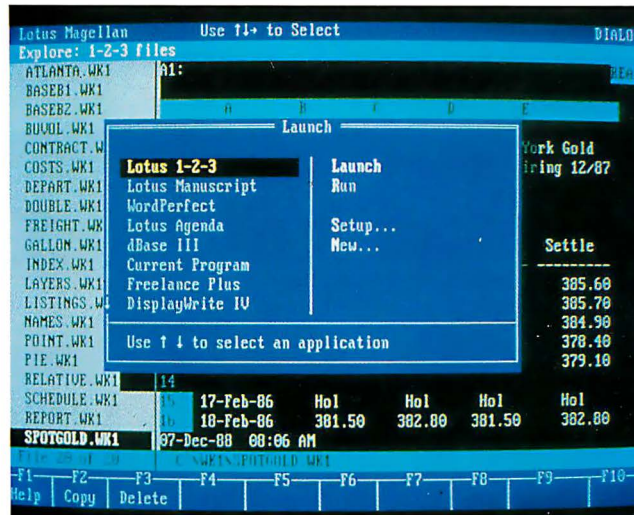

stamp, size, and so on.

I found both the file viewer and the index with fuzzy searching to be powerful and clever, but I do have some criticisms.

After years of performing text searches, I missed the specificity of exact matches. Often, my goal is not to gather loosely related information but to find a specific citation. My biggest complaint is with the speed of travel within view windows. The index helped me find files quickly, but having done so, locating matches within a file was a lot slower.

In all fairness, I must confess a tough precondition: I try to use every software package I evaluate without first reading the manual. Although Magellan uses conventions made familiar by Lotus 1-2-3, like highlighted options and first-letter or cursor selection of actions, I sometimes got lost in the program. Like any sophisticated product, Magellan has features and power not immediately apparent, but there were also basic functions I couldn't figure out without consulting the manual.

My biggest question about Magellan is that I'm not sure if finding files on a hard disk is as big a problem as Lotus would have you believe—especially because to solve this problem, you have to employ a new and different file management system that, for all its strengths, also introduces its own set of limitations. The basic directory/subdirectory organization has come in for criticism mostly from software companies trying to sell DOS enhancements.

Finally, your most important decision factor before buying Magellan is whether you use the applications that it now supports: Nonsupported data types can't necessarily be

continued

Circumnavigating the Disk with Magellan

Magellan is one of a growing number of DOS file management systems on the market designed to narrow the ease-of-use gap between IBM PC-compatible and Macintosh microcomputers. The Lotus product, similar to Norton Commander and XTree, lets you locate, organize, and sort files across multiple drives, directories, and sub-directories through a cursor-and-function-key interface.

Magellan also harnesses two software technologies that set it in a class by itself: a file indexing/text search system permitting rapid file retrieval with "fuzzy" search criteria, and a file viewer that lets you peer into the contents of files without loading the applications that generated them.

Magellan incorporates a proprietary new indexing scheme that requires only 6 percent to 7 percent of the space used by the source files, yet it is very fast. For example, in 9.5 seconds, I searched 12 megabytes' worth of files for references to software lawsuits and found 127 files (on a 20-megabyte hard disk drive in an 8-MHz 80286 machine).

To perform fuzzy searches

with Magellan, your queries can be English-like and free-form. For example, I looked for references to "optical or laser storage systems," and I found 146 files with three exact matches in 10.75 seconds.

Once you've selected a file, Magellan determines from its data structure which application program generated it and then calls up an appropriate viewer. The viewer shows the contents of the file in native mode (i.e., as it would appear inside the host application).

Magellan is fast enough that the view window fills almost instantaneously after the filename is highlighted, so you can really use the program to browse through your hard disk, file by file.

Using arrow keys, you can also enter the view window, scroll around inside the file, and copy sections to other files. Or, if you wish, you can launch into the application directly from the view window.

Like most shell programs, Magellan gets around the notorious inadequacies of DOS in file handling and file information presentation. You can gather files into groups, regardless of their paths, based on criteria like subject matter (via searches) or filename and extension (including logical NOT, useful for excluding irrelevant files), and you can display them by group or in a tree diagram. You can sort file groups very quickly by name and/or extension, date/time

THE FACTS

Magellan
\$139 until June 30;
\$195 thereafter

Requirements:
IBM PC or compatible
with 512K bytes
of RAM, DOS 2.1
or higher, and
a hard disk drive.

Lotus Development Corp.
55 Cambridge Pkwy.
Cambridge, MA 02142
(617) 577-8500
Inquiry 1025.

viewed, nor can their host applications be launched, from within Magellan. Applications that the program currently supports include Lotus

1-2-3, Symphony, Manuscript, Agenda, WordPerfect, DisplayWrite, dBASE, Word, WordStar, and MultiMate. You can also view ASCII files.

Although Lotus is confident that viewers will be developed for other applications, this will depend on whether Magellan becomes a market

standard. Until that happens, only users of the most popular programs will enjoy the full power of Magellan.

—Andrew Reinhardt

More Mac RAM for Less

One of the great dilemmas Macintosh II users face this year is whether to spend their hard-earned dollars on additional RAM for their systems (to run the new generation of memory-hungry applications on the market) or on a new hardware peripheral. Beyond 2 megabytes, you must add RAM in 4-megabyte increments. At the stratospheric price of \$1999 per increment, it's enough to make you consider buying a large hard disk drive or a tape backup unit instead.

Connectix now offers hope in the form of real virtual memory (where sections of code are swapped as needed from limited memory to and from a hard disk) for the Mac II with its appropriately named **Virtual**. Virtual implements 8 megabytes of demand-paged virtual memory using a software INIT, 2 megabytes of physical RAM, the Motorola 68851 paged-memory-management-unit (PMMU) chip, and an 8-megabyte contiguous region on your hard disk. Since the 24-bit addressing scheme of the current Mac operating system limits you to 16 megabytes (with half of that dedicated to ROM, I/O, and slots), you can obtain a maximum of only 8 megabytes of memory, virtual or otherwise.

Virtual works by using the PMMU chip to determine when a chunk of memory—called a page—should be swapped from disk into memory. In combination with the PMMU chip, a pseudo least-recently-used algorithm decides what part of RAM has had the least amount of activity and swaps that page out of the disk to make room for the page being loaded in. Natu-

rally, the more physical memory you have, the better your system's performance will be, since less time is spent swapping pages to the hard disk. If you've spent your cash on a high-speed hard disk drive, you'll also be rewarded with a more responsive machine.

You may notice a delay and some hard disk activity when you pull down a menu or click on a tool icon as the memory holding that piece of code loads into RAM and executes. This type of delay becomes particularly noticeable when you have many applications running under MultiFinder.

For this reason, Virtual is well suited for use with MultiFinder: The foreground application gets most of its code swapped into RAM, while all the background applications get their code swapped to disk. When you select a background application to work with, thus making it the foreground application, its code gets swapped back in as you use it.

Nevertheless, Virtual has its limits. If you're working with huge sets of data or have many large applications running, Virtual can get in a situation called *thrashing*, where it spends more time swapping

pages to and from disk than executing code. The only solution to this problem is to use smaller data sets, run fewer applications, or (ouch!) buy more RAM. Also, Virtual might not work with NuBus boards or certain SCSI peripherals that write directly to RAM, thus bypassing the virtual memory system.

Virtual comes in two versions. The first one costs \$695 and supplies the PMMU chip and the software INIT. For those who already have a PMMU chip installed, there's a software-only version for \$295.

I installed Virtual on a Mac II equipped with a 40-megabyte internal Apple hard disk drive, 2 megabytes of RAM, and SuperMac's Spectrum/24 video board and 19-inch monitor. The chatty 34-page manual has plenty of information on how Virtual works, tips for using it with MultiFinder, a troubleshooting guide, and four photos that show exactly how to remove the hardware-memory-mapper-unit chip inside the computer and replace it with the PMMU chip. After that, it's just a matter of dragging the INIT to the start-up disk's System Folder and restarting the Mac.

I used my typical day-to-day mix of applications with Virtual: the MindWrite 2.1 word processor, Think C 3.0, ResEdit 2.1, PixelPaint 1.0, MasterJuggler, Mathematica 1.1, and the usual army of utilities and INITs. Unfortunately, Virtual 1.0 gave me intermittent crashes, and it hung if I tried using an external SuperMac 150-megabyte Data-Frame hard disk drive as the start-up disk. It did work with

continued



THE FACTS

Virtual
with PMMU, \$695;
software only, \$295

Requirements:
Mac II with 2 megabytes
of RAM and a hard
disk drive running
System 6.0.2/Finder 6.1
or higher.

Connectix
125 Constitution Dr.
Menlo Park, CA 94025
(415) 324-0727
Inquiry 1026.



Embedded systems designers have already used CrossCode C in over 357 different applications.

How to choose a 68000 C compiler for your ROMable code development

These twelve important CrossCode C features could make the difference between success and failure

It's hard to know ahead of time what features you'll be needing in a 68000 C compiler. But if you're using CrossCode C you won't need to think ahead, because CrossCode C is already equipped with these twelve important features for your ROMable code development:

1. **A 100% ROMable Compiler:** CrossCode C splits its output into five memory sections for easy placement into ROM or RAM at link time.
2. **Integrated C and Assembler:** You can write your code in any combination of C and assembly language.
3. **Readable Assembly Language Output:** The compiler generates assembly language code *with your C language source code embedded as comments*, so you can see each statement's compiled output.
4. **Optimized Code:** CrossCode C uses minimum required precision when evaluating expressions. It also "folds" constants at compilation time, converts multiplications to shifts when possible, and eliminates superfluous branches.
5. **Custom Optimization:** You can optimize compiler output for your application because *you* control the sizes of C types, including pointers, *floats*, and all integral types.

6. **Register Optimization:** Ten registers are reserved for your register variables, and there's an option to automatically declare all stack variables as *register*, so you can instantly optimize programs that were written without registers in mind.

7. **C Library Source:** An extensive C library containing over 47 C functions is provided in source form.

8. **No Limitations:** No matter how large your program is, CrossCode C will compile it. There are no limits on the number of symbols in your program, the size of your input file, or the size of a C function.

9. **68030 Support:** If you're using the 68030, CrossCode C will use its extra instructions and addressing modes.

10. **Floating Point Support:** If you're using the 68881, the compiler performs floating point operations through the coprocessor, and floating point register variables are stored in 68881 registers.

11. **Position Independence:** Both position independent code and data can be generated if needed.

12. **ANSI Standards:** CrossCode C tracks the ANSI C standard, so *your* code

will always be standard, too.

There's More

CrossCode C comes with an assembler, a linker, and a tool to help you prepare your object code for transmission to PROM programmers and emulators. And there's another special tool that gives you symbolic debugging support by helping you to prepare symbol tables for virtually all types of emulators.

CrossCode C is available under MS-DOS for just \$1595, and it runs on all IBM PCs and compatibles (640K memory and hard disk are required). Also available under UNIX, XENIX, and VMS.

CALL TODAY for more information:

1-800-448-7733
(ask for extension 2001)

Outside the United States, please dial

PHONE: **1-312-971-8170**
FAX: **1-312-971-8513**

SOFTWARE DEVELOPMENT SYSTEMS, INC.
DEPARTMENT 21
4248 BELLE AIRE LANE
DOWNERS GROVE, ILLINOIS 60515 USA

CrossCode™ is a trademark of SOFTWARE DEVELOPMENT SYSTEMS, INC. MS-DOS® is a registered trademark of Microsoft. UNIX® is a registered trademark of AT&T. XENIX® is a registered trademark of Microsoft.

an external Rodime Model 140 Plus 140-megabyte hard disk drive using the 2.10 driver. A call to technical support at Connectix got me the latest version (1.03) of the INIT: We linked our Macs by modem and used the XMODEM protocol to transmit the new INIT to me.

Since then, Virtual has been solid and reliable. I've managed to hang the machine

only once, and it took a lot of effort. Avalon Development's PhotoMac application also causes Virtual to hang. Connectix is aware of the problem. Be sure to check with Connectix to see that your hard disk drive and applications are compatible with Virtual.

Nevertheless, it's nice to cut and paste graphics from Mathematica (which uses 2.5 megabytes) to PixelPaint (using 2

megabytes) on a Mac II with only 2 megabytes of physical RAM. I've run a Howtek Scanmaster color scanner on the system with no problems. MultiFinder really sings when you have enough RAM to load a lot of applications, and the background printing is nice once you can make use of it.

Virtual's price is attractive, considering what you'd have to spend to get the equivalent

physical memory (\$3998). If you're lacking a PMMU chip in your Mac II system, it's a good way to get one, particularly with Apple's own 32-bit operating system and virtual memory implementation due sometime this year. If your work demands acres of RAM, but you're short of both memory and cash, Virtual provides a cost-effective alternative.

—Tom Thompson

Turn Your Compaq into a LAN Server with Gigabytes



Modern applications like LANs, multiuser environments, and very large databases require fast, heavy-duty hard disk storage. Previously,

Compaq owners were limited to using only one large hard disk drive. But, with the **Compaq Fixed Disk Drive Expansion Unit**, you can have up to 1.2 gigabytes of on-line hard disk storage.

The Expansion Unit is an external hard disk system for Compaq computers. It features one or two 300-megabyte hard disk drives, an ESDI hard disk drive controller card, a case with a built-in power supply, a 4-foot connecting cable, and software. You can also install two Expansion Units in one system.

The two drives in my review unit were MiniScribe 9380Es. This 5¼-inch full-height drive has a very fast 16-microsecond access time and a 1-to-1 interleave. Coupled with the 16K-byte forward-reading buffer on the controller card, Compaq says, the system has a data transfer rate of 10 megabits per second.

I tested the Expansion Unit

with a Compaq Deskpro 386/20e and found that it's easy to install. First, I had to remove the existing hard disk drives in my system, since the ESDI drives can't coexist with other types of hard disk drives and controller cards. Next, I plugged the ESDI controller card into a 16-bit slot. A cable connects the system with the external Expansion Unit. The Unit's size is 14½ by 6½ by 16½ inches, and it resembles the Deskpro computers.

Compaq recommends using its version of DOS 3.3. The Expansion Unit comes with a disk of utility programs, including replacements for the standard FORMAT and FDISK DOS programs and a CACHE program to create a hard disk cache in system RAM or expanded memory.

One interesting feature is that the drives are not limited to the 32-megabyte partition imposed by DOS. With the EXTDISK.SYS device driver program on the utility disk, you can partition each 300-megabyte drive as one logical

drive. Thus, you can have files as large as the total capacity of the drive.

When used on a LAN, you can configure the system to provide disk mirroring or disk duplexing. Disk mirroring, using one controller card and two identical drives, creates two drives with identical files. Disk duplexing, using two controller cards and two disk drives, improves the performance. The LAN with disk duplexing can service two read requests by accessing the drive that can perform the read operation faster.

Who needs all this storage space, and who's going to pay over \$13,000 to get it? Someone who needs a file server on a LAN, most likely. Compaq even throws in the software for using the unit with the Novell LAN system. At first glance, the Expansion Unit appears to be a very expensive peripheral, but combined with a fast 80386-based system, it's the type of hardware that dreams are made of.

—Stan Wszola

THE FACTS

Compaq Fixed Disk Drive Expansion Unit
\$6999; second
300-megabyte hard disk
drive, \$6499

Requirements:
Compaq Deskpro 286
or 386 computer,
Compaq's version of
MS-DOS 3.3 or higher,
and one full-length
16-bit slot.

Compaq Computer
Corp.
20555 FM 149
P.O. Box 692000
Houston, TX 77269
(713) 370-0670
Inquiry 1027.

MultiBoot Brings OS/2 Back to Earth

When I installed IBM's OS/2 1.1 on my system, little did I know that I was in for a rude surprise. The dual-boot feature that had been in the Software Development Kit versions of OS/2 and had let

me boot either DOS or OS/2 at start-up was gone. But thankfully, Bolt Systems has come to the rescue with a program called **MultiBoot**, which does away with the dual-boot prob-

continued

How To Get In On Our Frequent Flyer Program

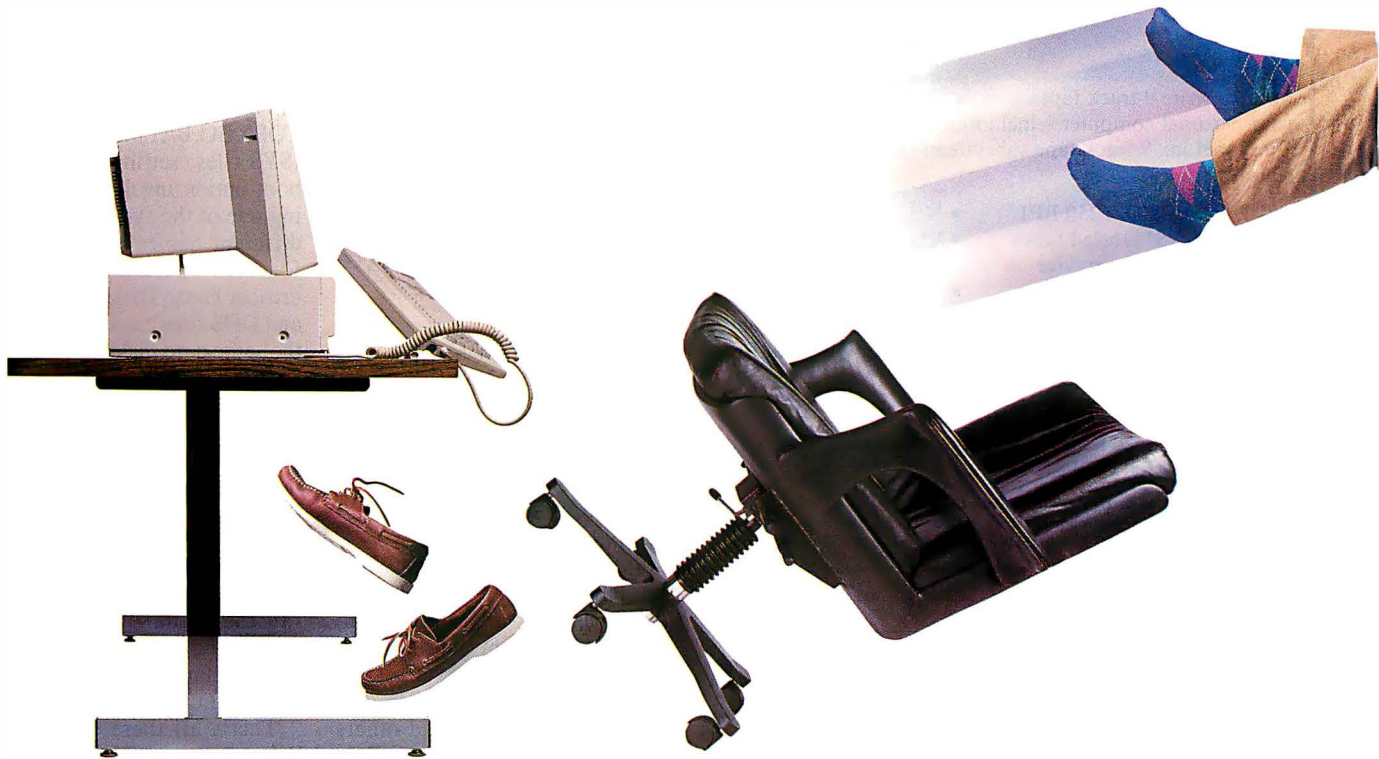

Our new software product will increase the speed of any PC system so dramatically that we're tempted to include a pilot's license (and seat-belt) as standard equipment.

We call it FAST! And from the moment you load it, you'll find that's an understatement. A *gross* understatement.

Using any benchmark or performance test you choose, FAST!

DATA TRANSFER RATES
IN KILOBYTES PER SECOND

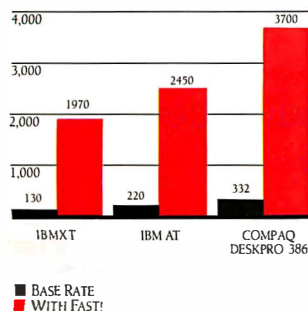

multiplies the actual processing speed of your system, by four times . . . six times . . . eight times . . . or *more*, depending on your system and application.

With FAST!, a IBM XT system easily outraces a Compaq Deskpro 386, using a standard data transfer performance benchmark. And without enhancing the hardware in any way.

We've got a winner on our hands.

Speed Enhancement, Without Hardware Upgrades

Our remarkable enhancement is achieved by very simple means. We took a well-known speed-enhancement technique called "disk caching," and improved it. By a mile.

FAST! literally anticipates what data your CPU will be seeking, and reads that data from your drive or floppy into a special RAM buffer (or "cache"), *before* the CPU asks for it.

Which means that your CPU spends almost no time waiting for disk reads, the most notorious time-

glutton of all. The more disk-intensive your application (database, for example), the more time FAST! will save you.

And since FAST! reduces drive read time drastically, it also reduces wear and tear on your drive, extending its life.

FAST! Blows Away The Competition

Priced at just \$99, FAST! is

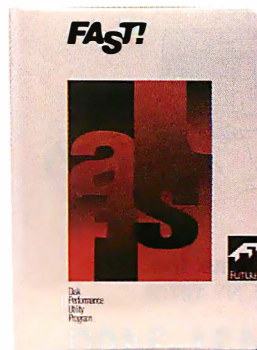

competitively priced with other disk-enhancement utility software. Yet it offers vastly superior results—four times the performance of the closest competitors.

And it's hundreds less than hardware upgrade options like faster drives, turbo boards, or entire system upgrades, while again offering superior speed enhancement. And FAST! works with XT, AT, 386 and PS/2 systems, in conventional, extended or expanded RAM.

If you want to give your computer breakneck processing speed, get FAST! To order, call Future Computer Systems at (603) 894-6975. Or, ask your local computer dealer. For FAX orders: (603) 894-6670



Future Computer Systems
26 Keewaydin Drive, Building H2
Salem, NH 03079
(603) 894-6975

XT, AT and PS/2 are trademarks of International Business Machines Corporation. Compaq DESKPRO 386 is a trademark of Compaq Computer Corporation. FAST! is a trademark of Future Computer Systems.

9-Track Tape Drives: Yes! for IBM PC/XT/AT/386 and PS/2

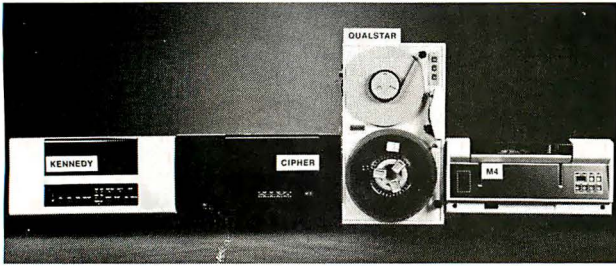

Read or write 9-track tapes from mainframes and minis to your personal computer - including the **PS/2 Micro Channel**. Our TapeLinx 9-track tape subsystems offer these important features:

- 800, 1600, 3200, 6250 BPI
- IBM & ANSI labeled tapes
- Quality customer service
- High speed controller
- Network backup
- EBCDIC/ASCII
- DOS, XENIX, UNIX
- DOS device driver

For quick delivery we stock all major manufacturers' tape drives including Cipher, Kennedy, M4 Data, Qualstar. Prices start at \$3,755. Call Today!



Overland Data Inc.

5620 Kearny Mesa Rd. • San Diego, CA 92111
Tel: (619) 571-5555 ext. 84 • FAX: (619) 571-0982

TapeLinx is a registered trademark of Overland Data, Inc.
IBM PC, XT, AT, PS/2 (Personal System/2) and Micro Channel are registered trademarks of IBM Corp.
XENIX and MS-DOS are registered trademarks of Microsoft Corp.

THE FACTS

MultiBoot \$49.95

Requirements:
An 80286- or 80386-based IBM PC, PS/2, or compatible with OS/2 Standard Edition 1.1 or higher, DOS 3.0 or higher, and a hard disk drive.

Bolt Systems, Inc.
4340 East-West Hwy.
Bethesda, MD 20814
(301) 656-7133
Inquiry 1028.

IBMBIO.COM, which must be the first file in your directory and start in the first sector of the hard disk. OS/2 also looks for a file called IBM-BIO.COM, but it doesn't care where it's located on the disk (as long as it's contiguous).

Since both DOS and OS/2 look for different system files that would otherwise have the same name, as well as for AUTOEXEC.BAT and CONFIG.SYS files, setting up a dual-boot option involves modifying one of the systems so that different names can be used for each operating system's critical files. Then both OS/2 and DOS files can be copied to the same hard disk. This is exactly what MultiBoot does.

Installation is easy. You need a floppy disk-based DOS boot disk, but I already had one. I booted my system under DOS from the floppy disk, ran a preinstallation program that automatically modified the OS/2 system files, and then ran the actual installation, specifying that I wanted DOS as my default start-up operating system.

That's all there was to it. When I rebooted my system, MultiBoot (which was appended to both my DOS and OS/2 boot records during installation) took initial control. If I don't take any further action, MultiBoot starts up DOS. But if I want to start up OS/2, all I need to do is press the Caps Lock key within 4 seconds.

MultiBoot is simple, inexpensive, and foolproof, and it works flawlessly. It's a good example of a utility that fills a much-needed niche.

—Stan Miastkowski

lem for good. Now that it's installed in my system, I can boot either operating system from my hard disk. [Editor's note: *For more on MultiBoot, see Mark Minasi's OS/2 Notebook in this issue.*]

Sure, OS/2 does have the compatibility box, which ostensibly lets me run DOS applications from within OS/2. But I've found that some DOS programs just don't run correctly in the box, and others slow down appreciably. Furthermore, I was chagrined to find that in order to start my system in DOS, I'd need to create a DOS start-up disk, on a floppy disk no less. It took me nearly an hour to make up the disk and get DOS back up on my screen.

MultiBoot, on the other hand, automates the process of booting under either OS/2 or DOS. The reason dual booting is possible at all is the result of the different ways DOS and OS/2 start up. When you start DOS, it looks for a file called

Disk Technician Advanced Keeps Disks Virile

The weak link in any micro-computer is the one you depend on for so much, your hard disk drive. Because it's an electromechanical device and works with tiny toler-

ances, a hard disk drive does wear. Platters warp, heads get out of alignment, and the repeated stresses and strains of on/off cycling take their toll.

continued

Top Quality HPI

HEWLETT PACKARD

Authorized Dealer

Impact Computer Systems, Inc.
Glen Wild Rd. Glen Wild, NY 12738

Call Now 1-800-431-3400

In N.Y. State 914-434-3338

Now In Stock!

Hewlett-Packard Supplies

CAD Plotters from Hewlett-Packard

- Fast Service
- Fast Delivery
- Low Prices
- Corporate Accounts Welcomed

Because Resources Should Be Shared

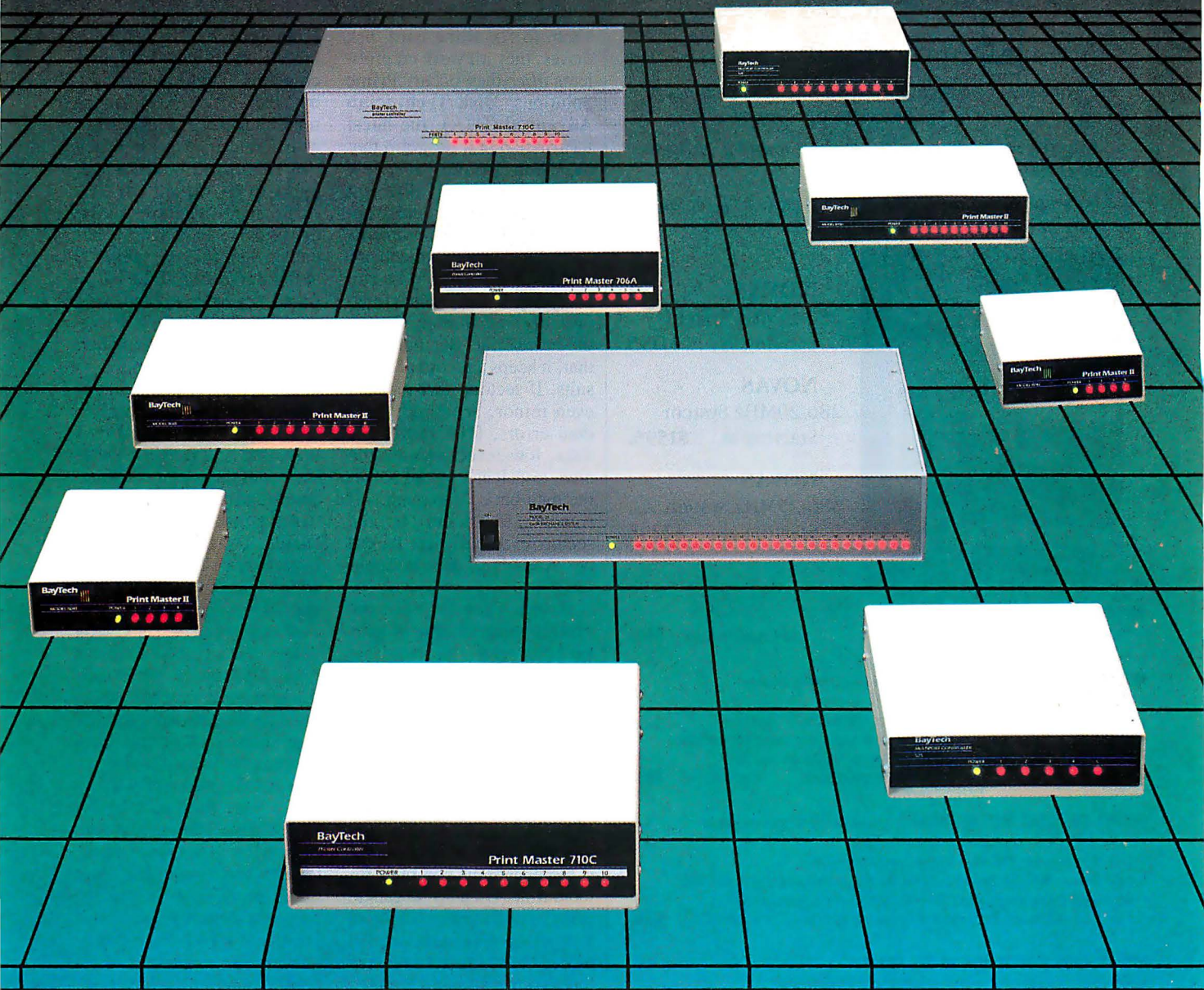

BayTech engineers resource sharing solutions.

Because we know your applications for sharing printers, plotters, modems and data are unique, BayTech has developed over 30 resource sharing products, which offer you a broad range of solutions for sharing your resources.

We realize that you shouldn't have to fit your application to the specifications of a single product. With BayTech, you select the

model that meets *your* needs.

From simply sharing one or more printers between computers, to creating a complete network of computers, printers, plotters and modems, BayTech has a product designed for you.

Call us toll-free today. Our technical support staff will show you how to make the most of your resources.



*Bay Technical Associates, Inc.
Data Communications Products Division
200 N. Second Street, P.O. Box 387
Bay St. Louis, MS 39520 USA
FAX: 601-467-4551
Telex: 910-333-1618 BAYTECH
Phone: 601-467-8231 or toll-free*

800-523-2702

NEW FROM **NOVAS**



HONORED BY PC MAGAZINE

"...It gave better performance than ALL the machines of this group on most of the processor benchmark tests..."

"...Working my way down the tower, I found a 'NOVAS SUPER TURBO 286X MOTHERBOARD'..."

"...It's so flexible that it makes living without a big name no chore at all..."

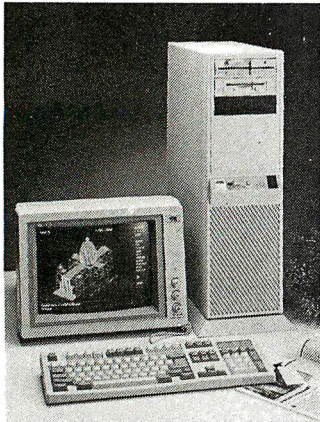

NOVAS
286-14MHz System
Starting at . . . \$1195

NOVAS
286-20MHz System
Starting at . . . \$1595.

NOVAS
386-25MHz System
Starting at . . . \$2295

NOVAS 386SX MOTHERBOARD

• 386 power without the 386 price.

NEVER MORE THAN... \$495

NOVAS 386 MOTHERBOARD Available in 25/20/16MHz versions

- 80386 by Intel, AMI Bios, EMS Support
- Chips & Technologies 386 CHIPset, sockets for 80287 & 80387/Weitek
- Expandable to 16MB (Simm) on board, Interleave/page mode memory 0 wait state
- Shadow RAM, Independent Clock, On board battery, 8 I/O expansion slots
- 1 serial & 1 parallel port on board (optional 2nd serial port). STARTING AT... \$895

NOVAS 286 NEAT MOTHERBOARD available in 20/16/14MHz versions

- 80286 CMOS by Harris, AMI Bios, EMS 4.0 support
- Chips & Technologies 286 NEAT CHIPset, socket for 80287
- Expandable to 8MB (Simm) on board, Interleave/page mode memory 0 wait state
- Shadow RAM, Independent Clock, On board battery, 8 I/O expansion slots
- 1 serial & 1 parallel port on board (3 more optional serial ports). STARTING AT... \$345

NOVAS 4000 SUPER VGA 16 BIT CARD

- 100% IBM compatibility at register plus gate level, Shadow RAM
- Expandable to 1MB of display memory, Supports 132 columns for Lotus 1,2,3
- Chips and Technologies 450 VGA product line chips, Analog & Digital Outputs
- 640 x 480 in 256 colors, 800 x 600 in 16 colors, 1024 x 768 in 4 colors
- Backward capability to EGA, CGA, Hercules, and MDA. NEVER MORE THAN... \$395

NOVAS 386-20MHz w/64k CACHE CONTROLLER

- Increases performance up to 25% NEVER MORE THAN... \$1495.

"...FULLY LICENSED TO UTILIZE  PATENTS..."



Quality Products From
COMPUTRADE CO.
780 MONTAGUE EXPRESSWAY,
SUITE 501, SAN JOSE, CA 95131

OEM, VARS, & DEALERS WELCOME
Corporate & University Discounts

*Service in USA

**VGA, XT, AT & IBM are trademarks of International Business Machines
Prices & specs subject to change

U.S. SALES: (408) 435-2662
U.S. FAX: (408) 435-5458

SHORT TAKES

Although many programs claim to fix ailing hard disk drives, they all work on problems *after* they occur. Prime Solutions' **Disk Technician Advanced (DTA)**, the latest incarnation of a program that has been around for a few years, is an entirely different animal. It takes the unique approach of predicting problems and taking steps to avoid them.

DTA is designed to be run every day. Its approach is to repeatedly and thoroughly test the entire drive. But more than that, it keeps a record of its results. If sectors start to show even minor, seemingly random errors, DTA moves the data, low-level formats the area, tests it again, and moves the data back. If enough soft (random) errors show up, the sectors eventually get locked out. And it's all done automatically.

If you tell it to, DTA also optimizes the interleave of your hard disk drive. I've found that many hard disk drives have interleaves that are too high. DTA tests the disk for optimum interleave and changes it on the fly. This can result in increased performance.

DTA performs three levels of testing: daily, weekly, and monthly. Each level of testing is more rigorous and requires more time. On a 30-megabyte drive, a daily test takes about 5 minutes, a weekly test 1½ hours, and the exhaustive monthly test almost 4 hours.

Over a three-month period, I ran DTA on five different machines. Two of the machines had identical 32-megabyte hard disk drives, and the remaining three used a variety of different drives with capacities ranging from 20 megabytes to 64 megabytes. It's surprising to see how similar drives can behave very differently when they're subjected to regular testing. DTA hasn't found a single problem with one of the 32-megabyte drives, while the other one has numerous soft and hard errors.

I also tried to trick DTA by using a run-length-limited controller with a hard disk drive that isn't rated for the 26 sectors of the RLL controller. So instead of the 20 megabytes that the disk was designed to handle, it was formatted for 30 megabytes. This situation, which I don't suggest you try, put DTA to the supreme test, and it passed with flying colors. Nearly every time it runs, DTA finds soft errors. It's kept itself very busy moving data around and reformatting sectors. And the drive continues to work just fine.

You can run DTA from either your hard disk or the floppy disk. I found that running it from a floppy disk, though less convenient, does make more sense since the program also keeps a record of your disk's FAT (file allocation table), enabling it to recover data after a drive crash. DTA also comes with a resident automatic head-parking utility that consumes a paltry 700 bytes of RAM.

Early versions of the original Disk Technician occasionally had their problems, but DTA is now a mature, reliable, and versatile product. It works with virtually all hard disk drives and controllers, and it isn't copy-protected. At first glance, I thought that its \$189.95 price tag was very high. But the more I use it, the more I realize that it's a true bargain—a veritable fountain of youth for your hard disk drives.

—Stan Miastkowski ■

THE FACTS

Disk Technician Advanced
\$189.95

Requirements:
IBM PC, PS/2, or compatible with at least 512K bytes of RAM, DOS 2.1 or higher, and a hard disk drive.

Prime Solutions, Inc.
1940 Garnet Ave.
San Diego, CA 92109
(619) 274-5000
Inquiry 1029.

DESKTOP MAPPING ENTERS THE MAINSTREAM

Fortune 500 companies are playing *visual "what-if"* with their databases

When The Wall Street Journal, Forbes magazine, Business Week and Financial News Network start covering a new type of software, it's a good indication of the potential for mainstream business use. That is what has happened to MapInfo Corp.'s MapInfo desktop mapping software — and in just over a year's time.

Part of the cause for the groundswelling interest in MapInfo is the recent estimates that 80 percent of business organizations with PC's can benefit from this new tool, once they discover its capabilities. In fact, MapInfo is being used in over 100 different applications by corporations, governments, and utilities. Here are some examples:

■ Fortune 500 companies are using MapInfo, and for many different purposes. They are displaying information about existing customers, prospects, and market demographics on a variety of street, regional, national or world computer maps. Some, with thousands of outlets or branches

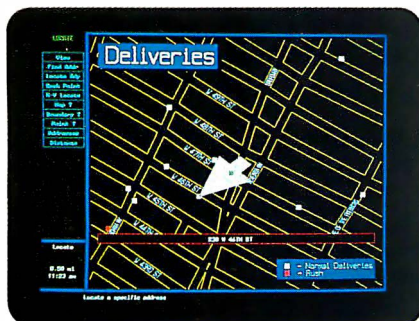

Find Addresses MapInfo Corp.'s street maps come with every address already in place, accurate to the correct block and side of street. Simply type an address and MapInfo locates it for you. Or, automatically plot existing data on the map for "what-if" analyses.

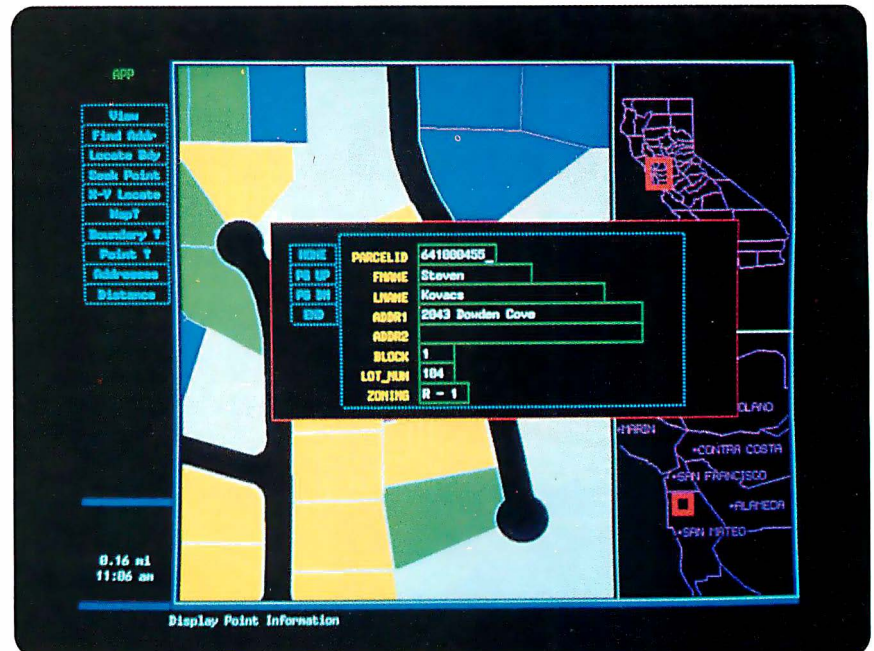

Database Information Merged With Maps MapInfo is the only software designed to directly tie dBASE files with maps. The parcels shown here were auto-matically shaded based on the data about each. A window is displayed that reveals the actual data behind a particular parcel.

nationwide, are using MapInfo to optimize allocation of resources. Others are plotting their delivery sites on computer maps with MapInfo to help with routing and dispatch.

■ Government is using MapInfo in a big way, from federal applications right down to the local level. In fact, cities and towns across the nation are using MapInfo's computer map of their municipalities to monitor highway maintenance, store zoning information for land use, maintain accurate tax parcel maps for proper assessment, and establish efficient snow and garbage removal patterns. And their police, fire, and emergency services also picked up quickly on the power of MapInfo for speeding the delivery of their services, as well as making them more efficient, and adding a whole new trend analysis capability.

■ Utilities, including telephone, cable, electric and gas, are finding MapInfo to be an indispensable tool. MapInfo lets them draw their networks onto existing computer street maps and plot all existing customers and prospects to help with route planning,

new installations, maintenance and overall facilities management.

Since every address is already in MapInfo's metro street maps—to the correct block and side of street—anyone can use MapInfo to instantly find the location of specific addresses, or to plot the locations of

"80 percent of business organizations with PC's can benefit from this new tool ..."

records in existing databases. Moreover, with MapInfo's capabilities, anyone can play a visual "what-if," for everything from planning their reseller networks, sales territories, distribution routes, promotional campaigns, resource allocation, and so forth.

That's just a small sampling. MapInfo Corp. has set up a toll-free hot line to answer questions about your applications. For more information write to MapInfo at 200 Broadway, Troy, NY 12180, or call 518-274-8673, or 1-800-FASTMAP toll free.

Power



T5200: 20MHz 386 processor, 2 internal IBM®-compatible expansion slots, VGA gas plasma display with VGA monitor port, 40MB or 100MB hard disk, 2MB RAM standard expandable to 8MB, 1.44MB 3½" diskette drive.

At Toshiba, we're not only committed to making computers more portable, but also to making portables more powerful.

Which is why, in our effort to constantly improve and refine our machines, we've added three new computers to what is already the most complete family of truly portables available.

Each designed to be powerful enough to take on the increasingly complex tasks that face today's sophisticated PC users.

First, the T1600 which weighs under 12 pounds and which is the fastest battery-

powered computer we've ever made.

Second, the T3100e, the successor to our most popular machine—the T3100/20. We've made it nearly two pounds lighter and a lot faster—we've even added expansion capabilities. About the only thing we didn't add was more size.

T1600: Battery-powered 286/12MHz, coprocessor socket, 20MB hard disk at 27msec, 1.44MB 3½" diskette drive, 1MB RAM expandable to 5MB, detachable backlit EGA compatible LCD, removable rechargeable battery pack.

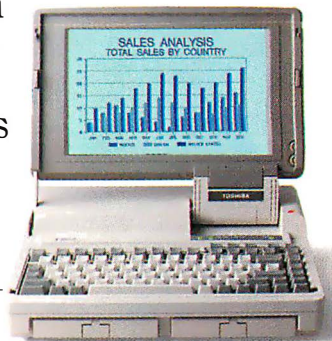

Toshiba is the world leader in truly portable PCs and manufactures a complete line of high quality dot-matrix and laser printers. For more information call 1-800-457-7777. All Toshiba PCs are backed by the Exceptional Care program (no-cost enrollment required). IBM is a registered trademark of International Business Machines Corporation. Model T5200 has not been approved by the Federal Communications Commission. This device is not, and may not be, offered for sale or lease, or sold or leased until the approval of FCC has been obtained.

Surge.



And finally, the T5200, which has enough power to replace virtually any desktop PC.

But we haven't just concentrated on power and portability. We've also constantly looked for ways to make our machines more durable, more reliable, and easier to use—down to the 800 number our customers can call for help with any technical question that might come up.

We figure that's what our users demand.

And it's by anticipating the growing needs of our users that we have continually found ways to make our machines weigh

less and do more. So you can work wherever you want and however you want.

All of which might make it tempting for some people to abandon their desktop for the convenience of portability. Go ahead.

We've given you the power to do it.

T3100e: 12MHz 286 with 80287 co-processor socket, internal half-length IBM slot, 20MB hard disk with 27 msec access, 1MB RAM expandable to 5MB, gas plasma display, 1.44MB 3 1/2" diskette drive.



In Touch with Tomorrow
TOSHIBA

Toshiba America Inc., Information Systems Division

Circle 267 on Reader Service Card
(DEALERS: 268)

MAY 1989 • BYTE 107

Two Powerful Systems from Sun

Thanks to a high-speed SPARC processor and a 68030 CPU, two externally identical new workstations from Sun offer workstation performance at PC prices

There has been much discussion about the blurring distinction between high-performance personal computers and low-end workstations. Indeed, this phenomenon is no longer a matter of conjecture and speculation; now, it's a reality. In recent months, there has been a flurry of new product announcements from traditional minicomputer and workstation vendors offering powerful, Unix-based machines for under \$10,000. Among the most competitive and important introductions are two new workstation product lines from Sun Microsystems.

The first of these is the Sun's new SPARCStation 1. It is one of the first systems based on Sun's high-performance SPARC chip. SPARC stands for Scalable Processor Architecture, which is the

Sun version of RISC architecture. The SPARCStation is said to perform at a rate of 12 million instructions per second (MIPS), yet it is priced at \$10,000.

Next, I'll look at the new Sun-3/80, a 3-MIPS machine using the Motorola 68030, with base prices starting at around \$5000. These two machines represent the entry-level systems of each of the new product lines.

An important, but optional, component of these new machines is a unique graphics accelerator, called the GX, which I will also describe in this article.

The product lines also include high-end members such as the Sun-3/400, a 33-MHz 68030 machine priced at around \$35,000, and the SPARCStation 300, which has a 25-MHz SPARC processor and starts at about \$25,000. I will not cover these higher-end machines in this article, although it should be pointed out that these machines offer full binary compatibility with their entry-level counterparts.

At first glance, the Sun-3/80 and SPARCStation 1 stack up favorably against comparably priced personal computers, such as the Mac II, the IBM PS/2 Model 80, and even the NeXT computer. However, these new machines are still very much traditional Unix workstations, and there is no interface "layer" insulating the user from the Unix operating system. In other words, there is no slick graphical interface such as NextStep or the Macintosh interface, although there are development tools for creating such interfaces. But the bottom line is that you have to know Unix to use these machines and you have to rely on individual applications developers to provide a friendly interface. Sun says this will change, but as of this writing, if you buy one of these workstations, be prepared to learn Unix.

Another thing about Sun workstations is that you can't just hop down to ComputerLand and buy one. They are distributed through direct sales and value-

added resellers. Your local newsstand will probably not feature magazines advertising software for Sun workstations. You need to get Sun's huge Catalyst catalog; with it, you can order software directly from the vendors. Nevertheless, these are machines that deserve serious consideration for serious work. They provide excellent graphics, high performance, and a substantial software base.

From the Outside Looking In

Externally, the SPARCStation 1 and the Sun-3/80 are identical machines (see photo 1). The system unit for each is a sleek 16- by 16-inch package, only 2½ inches high, designed by Frog Design, which is also responsible for the NeXT computer's external design. It features a universal 85-watt power supply and bays for one 1.44-megabyte 3½-inch floppy disk drive and two 100-megabyte 3½-inch hard disk drives. The 100-megabyte drives have an average access time of 23 milliseconds and throughput of about 1.2 megabytes per second. An optional expansion box is also available that can store a 327-megabyte 5¼-inch hard disk drive as well as a 150-megabyte tape backup unit.

Both the 3/80 and the SPARCStation come with an optical mouse and an IBM PC AT-compatible keyboard (called the Type 4 keyboard), which has been standard on the 80386-based Sun386i, introduced last year (July 1988 BYTE). This keyboard is now standard on the entire Sun product line.

A variety of monitors are available with the systems. They range from 17- and 19-inch monochrome and gray-scale monitors to 16- and 19-inch 8-bit color monitors, all with 1152- by 900-pixel resolution.

The rest of the machine resides on an 8½- by 11-inch logic board. It is on the logic board where the similarity ends between the Sun-3/80 and the SPARCStation 1 (see photo 2).

continued



Photo 1: *The SPARCStation 1 and Sun-3/80 (inset). The exterior appearance and form factor are identical. The footprint is 16 by 16 inches. The SPARCStation 1 is shown with the new 17-inch monochrome display.*

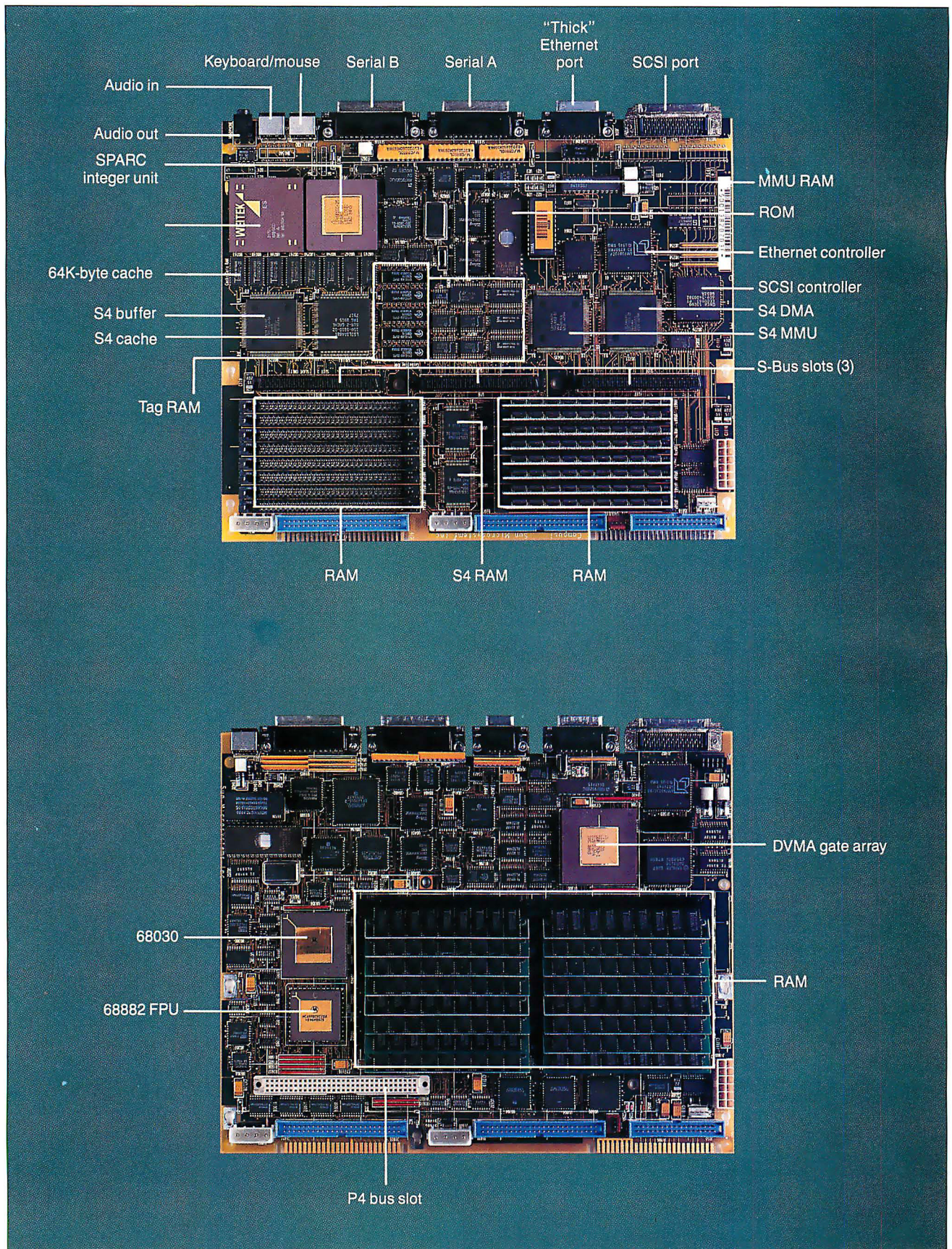

Photo 2: The logic boards for (a) the SPARCStation 1 and (b) the Sun-3/80. The SPARCStation board has three S-Bus expansion slots, versus the single P4 bus slot on the 3/80 logic board. Note the S4 DMA controller, which controls the DMA of the SCSI, Ethernet, and serial ports to the S-Bus. The SPARCStation board also features a 20-MHz SPARC CPU and custom FPU. The 3/80 features the 20-MHz 68030 and 68882 FPU.

The SPARCStation 1

The SPARCStation features a SPARC CPU with a clock speed of 20 MHz. A block diagram of the SPARCStation logic board is shown in figure 1. The machine comes standard with an FPU that offers performance of about 1.5 million floating-point operations per second (MFLOPS), which is about 10 times the performance of the Motorola 68882 FPU used in the Mac II, the NeXT computer, and the Sun-3/80.

The SPARCStation comes with 4 megabytes of RAM and is expandable to 16 megabytes. The system board currently uses 1-megabit single in-line memory modules, but it will accept 4-megabit SIMMs when they become available.

The logic board includes two serial ports, one Ethernet port, one SCSI port, and three expansion slots controlled by a new proprietary bus called the S-Bus.

The S-Bus is one of the most interesting features of the SPARCStation. It is a synchronous 32-bit bus that operates at the clock speed of the host CPU (20 MHz, in this case) and features direct memory access capability, allowing the CPU to offload much of the I/O processing to the separate DMA channels on the S-Bus.

The S-Bus is more than just an expansion-slot bus. It includes separate channels for the SCSI, Ethernet, and serial ports, which all have DMA and direct virtual memory access (DVMA) through the S-Bus. The CPU has access to a 64K-byte cache memory, allowing it to operate at full speed during most I/O operations. A six-chip VLSI chip set controls the cache, memory management, DMA and DVMA, the clock, the keyboard, and the mouse, as well as access to the peripheral ports (SCSI, Ethernet, and serial).

The S-Bus expansion slot connectors are used primarily for video cards, frame buffers, and graphics accelerators, and possibly for a second Ethernet card. Add-in boards are 5 by 4 inches and can be either single- or double-sided. It should be noted that the S-Bus is a multiple master bus. This means that, in addition to the CPU, the S-Bus expansion cards (e.g., an Ethernet controller) can temporarily take control of the bus for faster processing. The three-slot S-Bus on the SPARCStation has two master slots and one slave slot.

The S-Bus can operate at burst data transfer rates of about 60 megabytes per second, which is several times faster than the VME bus used on other Sun workstations and on many Unix-based workstations from other vendors.

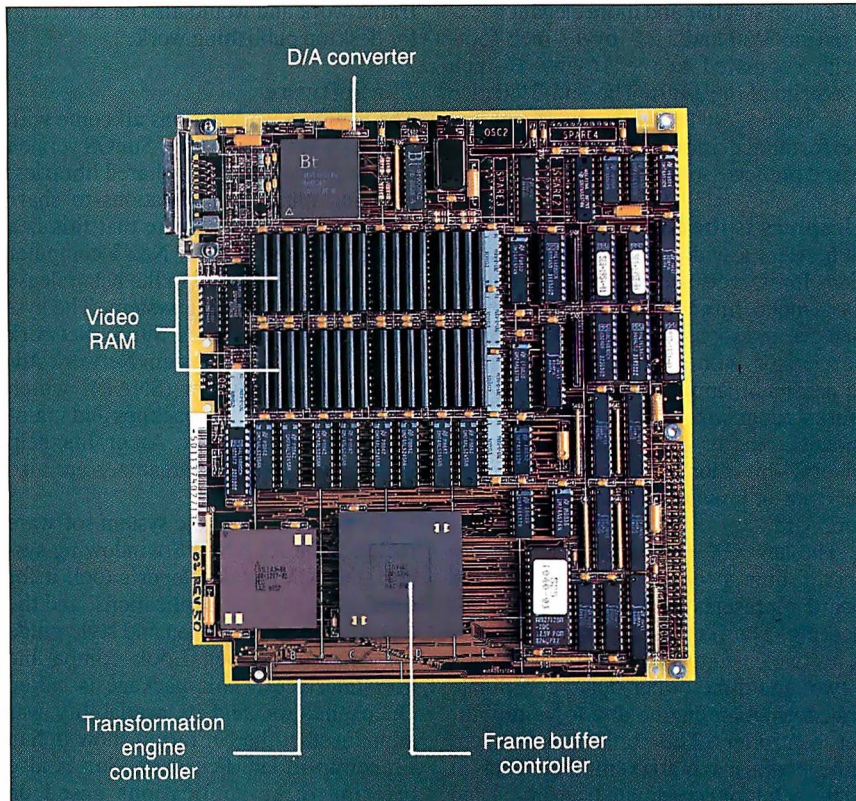

Photo 3: The GX graphics accelerator card. Note the two gate arrays on the lower left side of the board. The left chip is the coordinate transformation engine. The right one is the frame buffer controller.

The S-Bus is currently available only on the SPARCStation 1, but it will become the standard bus on future Sun machines (however, higher-end machines will continue to offer VME slots in addition to Sun's proprietary bus architecture).

The SPARCStation includes a single-channel audio interface chip and an internal speaker as well as a jack for connecting to external speakers. The system software, which is discussed later in the article, includes a Sound Tool which can handle 8000 8-bit samples per second. However, the audio capabilities of the SPARCStation are fairly minimal when compared to either the Apple Sound Chip or the sound capabilities of the NeXT computer. Graphics and numeric processing are the real strong points of the SPARCStation.

The Sun-3/80

The Sun-3/80 is the successor to the popular Sun-3/50 and -3/60 workstations. Although SPARC may be Sun's architecture for the future, the company is not about to abandon its large Motorola user base. Motorola-based machines still account for over 60 percent of Sun's reve-

nues, and there is a large investment in Sun-3 software. So, rather than neglect its Motorola line, Sun has greatly improved it by stepping up to the Motorola 68030 processor.

The Sun-3/80 features a 20-MHz 68030 and a standard 68882 FPU. The 3/80 uses the same single-slot, proprietary 32-bit asynchronous bus as the earlier Sun-3 models. This bus, called the P4 bus, also provides high performance like the S-Bus, but it does not include the DMA or multiple master capabilities of the S-Bus.

Sun is sticking with the P4 on its Motorola line and also on its higher-end SPARC machines simply to provide compatibility with the earlier models (in other words, users can upgrade to these new machines and still use their old frame buffer cards).

The Sun-3/80 comes standard with 4 megabytes of RAM (made up of 1-megabit SIMMs) and is expandable to 16 megabytes. The logic board has two serial ports, one parallel port, one Ethernet port, and one SCSI port. The machine does not have audio capability.

Basically, the Sun-3/80 is a Sun-3/60

continued

in a much smaller and more elegant package (the 3/60 had a 21- by 17-inch footprint compared to the 16- by 16-inch footprint of the 3/80). The Sun-3/80 also offers a modest 10 percent to 15 percent performance increase over its 68020-based predecessors.

Graphics Is the Key

Sun offers a wide range of graphics options for its workstations, ranging from a basic monochrome frame buffer to an expensive and sophisticated 32-bit graphics accelerator with Z-buffering for three-dimensional applications. The low-end workstations are usually equipped with monochrome or color frame buffers (8-bit or 24-bit color) or with the new GX 8-bit color or gray-scale graphics accelerator board.

The new GX graphics accelerator deserves some special attention because the board represents some innovative engineering. The GX board (see photo 3) features two custom gate arrays that provide a two- and three-dimensional coordinate transformation engine and a frame buffer controller. The transformation engine performs matrix mathematics at high speed for coordinate translation and rotation, scaling, and pan and zoom. It also controls a 32- by 32-pixel hardware cursor that eliminates the cursor overlay plane in memory, used in most conventional frame buffers. Results from the coordinate transformation engine are sent directly to the frame buffer controller, which performs antialiasing, raster operations, clipping, and bit-blt operations. The board has 1 megabyte of video RAM, which interfaces through the D/A converter to the 1-megapixel display.

According to Sun engineers, the performance of the GX board depends entirely on the processing power of the host CPU and FPU. The GX can execute coordinate transformations up to a theoretical performance limit of 51 MFLOPS. It has been benchmarked at about 15 MFLOPS when running with a Motorola 68020, according to Sun engineers.

But you have to see the GX in action to appreciate its performance. In a demonstration on a Sun-3/60, the GX showed blazing speed in everything from text scrolling to pan and zoom on highly complex circuit diagrams. Sun claims that the GX offers up to 50 times the performance of conventional frame buffers.

The GX board fits in either the Sun-3/80 or SPARCStation 1 (P4 or S-Bus configurations). In the SPARCStation, the GX board takes up two expansion slots. The GX board is ideal for two- and three-dimensional drafting and wire-

frame work and would also be beneficial for desktop publishing work.

The Software

The new Sun workstations all come with the Sun's version of Unix, SunOS version 4.0. SunOS 4.0 features shared libraries, allowing multiple applications to share libraries in memory. Note that this is a feature promised for the NeXT computer but was not functional in the beta release of the NeXT operating system. The system software includes Sun's Network File System and the System Network Administration Program (SNAP), which allows automated file backups and maintenance on the network. An on-line help facility and Desktop Organizer are also included.

On top of SunOS, the system software includes the X11/NeWS windowing system, the X/View developer's toolkit for developing window applications, and the Open Look specification and style guide for designing Open Look-compatible user interfaces. This package is called OpenWindows, and its availability was announced at the Uniforum show in San Francisco in late February. Sun is also offering three applications based on Open Look: SunWrite, SunPaint, and SunDraw.

The OpenWindows package is fine for software developers working on Open Look applications. What is missing, however, is a standard user interface for end users. The customer still has to know how to install and "bring up" Unix on the system. And the end user still has to know how to load applications and how to execute Unix commands from the console. According to one Sun product manager, Sun will soon offer Unix preinstalled on the hard disk with a "plug and play" installation routine so that uninitiated users will be able to start up the system easily.

Having Unix preinstalled on the disk is certainly a step in the right direction. But Sun must recognize that it needs an easy-to-use, graphical user interface if it wants to be successful in the mainstream personal computer market. Engineers and students may have no problem picking up Unix. But less technical users are intimidated by the Unix command language, and with good reason.

The lack of a user interface represents a major deficiency in Sun's overall product offering. We can only hope that Sun rectifies this situation soon. It would be a shame to see such powerful and well-engineered hardware be compromised by the lack of equally well-engineered operating-system software.

Sun offers a wide range of programming languages and compilers, text editors, debuggers, and utilities. A recent addition is the Soft Co-Processor, an MS-DOS-emulation program from Phoenix Technologies, which Sun distributes under the name Dos Windows. In addition, there is indeed an enormous variety of third-party software applications available for SunOS, with everything from advanced scientific and statistical packages to desktop publishing software. While all SunOS applications will run on either the Motorola or SPARC architectures, there is no binary compatibility between the two architectures. Applications must be compiled separately to run on either platform (this compilation, of course, is taken care of by the software developer).

Pricing

At the time of this writing, Sun had not made final decisions on pricing. Price comparison is further complicated by the fact that Sun sells only complete systems; there is no price breakdown by components. I can give some ballpark estimates, however. The SPARCStation 1 will have a base price in the neighborhood of \$10,000. If you add a 100-megabyte hard disk drive and a monochrome monitor, the price will be about \$12,000. If you add the GX accelerator board, figure a total of about \$14,000.

By contrast, the Sun-3/80 starts at around \$5000. A color system with a 100-megabyte hard disk drive would cost about \$10,000. Add another \$2000 or so for the GX accelerator board. Again, these are rough estimates. By the time this article is in print, Sun will have announced more exact pricing.

When you put together a complete system, these machines are still well within striking distance of fully configured Mac IIs or IBM PS/2 Model 80s. The NeXT computer comes in substantially cheaper if you stick to the slow optical disk. But none of these machines offers the level of performance or graphics capability available in the SPARCStation 1. The Sun-3/80 equipped with the GX accelerator is also a formidable competitor.

The Sun-3/80 and SPARCStation 1 are impressive machines and will undoubtedly be very successful. The one missing link, however, is a powerful and easy-to-use graphical interface. With the addition of that link, these Sun systems would be hard to beat. ■

Nick Baran is a BYTE senior technical editor based in San Francisco. He can be reached on BIX as "nickbaran."

Intel's Cray-on-a-Chip

Designed as a microprocessor version of the Cray 1, Intel's new high-speed 80860 RISC microprocessor sports an on-chip FPU and a 3-D graphics processor

Last fall, speculation was running rampant about Intel's forthcoming 80486 microprocessor. Rumors circulated that it was a veritable mainframe-on-a-chip—a CPU so powerful that it could serve as the heart of the entire computer industry, from desktop microcomputers to supercomputers. Now it appears that some of those rumors weren't about the 80486 after all, but about another new chip from Intel, the 80860.

The 80860, Intel's first full-scale RISC processor, made its initial appearance in February at the IEEE's International Solid-State Circuits Conference in New York City. Known then only by its code name, "N-10," the chip appeared to be the highlight of the show. Intel's designers described their brainchild as a 64-bit processor containing 1 million transistors. It could run at up to 50 MHz and could perform at a rate of 105,000 Dhrystones per second—about 13 times faster than the fastest 80386-based system. Moreover, the 80860 included an on-chip FPU that was capable of performing 17 million floating-point operations per second (MFLOPS) and a three-dimensional graphics processor. The designers of the 80860 claimed that

it was a one-chip version of the Cray supercomputer.

Two weeks later, Intel officially announced the chip and dubbed it the Intel 80860. The new chip would be expensive, to be sure, but it wouldn't cost much more than a high-speed numeric coprocessor. Although the chip's RISC architecture prevents it from being 8088 compatible, it could become extremely popular nonetheless. When it becomes available next month, the 80860 should have a significant impact on graphics- and Unix-based systems.

When I set out to write this First Impression, I had three questions in mind. Exactly how good is the 80860? Is it really a Cray-on-a-chip? And if it's really that fast, how did it get that way?

YARP?

In some ways, you might tend to dismiss the 80860 as YARP—yet another RISC processor. Several other RISC processors are already available. One of the most popular is the SPARC chip set, which is used in the Sun-4 workstation line and the new Sun SPARCStation 1 (see page 108). Running second in popularity is the MIPS processor, which is the CPU for the Silicon Graphics Personal IRIS workstation (see "Silicon Graphics Brings Down Cost of 3-D Graphics," *Microbytes*, November 1988, page 16). A third contender, Motorola's 88000, is just beginning to appear in workstations from Opus, Everex, and Data General. A fourth is IBM's own RISC CPU, the processor used in IBM's RT PC. The RISC processor market has become so crowded, in fact, that one chip maker, AMD, has decided to pull its RISC chip, the 29000, out of the competition.

But the 80860 is special in several ways. First, while its more established competitors are actually chip sets, the 80860 is a single chip. The SPARC, for example, uses separate chips for integer

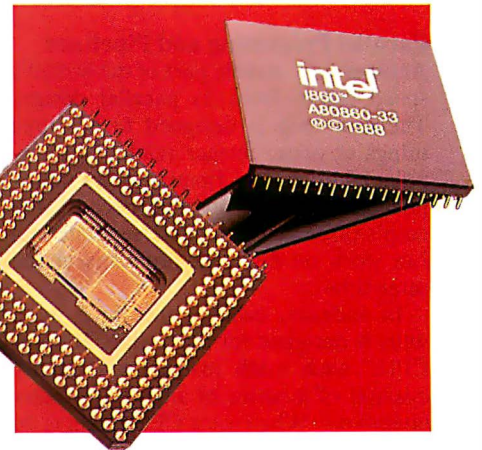

math, floating-point math, memory management, and other functions, typically five chips in all. The 88000 improves on that; it has all the math functions on one chip and requires only two extra chips for instruction and data caches. By contrast, Intel designed the 80860 with a million transistors, which allowed the designers to fit everything, including the memory caches, on a single chip. Among other things, this means that the 80860 will take up less space on printed circuit boards or add-in cards, and it should use less power.

But there's another advantage to having everything on a single chip: speed. RISC processors, after all, are purposely designed to run fast. Their instruction sets have been pared down to a bare minimum of simple instructions that can each be performed in a single clock cycle. In the case of very fast processors, however, when memory is on one chip and the processor is on a separate one, the transfer of information from one chip to another cannot keep up with the CPU's internal speed. Faster RAM helps, but there is still a natural speed limit to how fast you can move data around on a printed circuit board. And when you are trying to save

continued

nanoseconds, even the small distances between chips can seem like light-years.

With everything on a single chip, the 80860 sidesteps many of these delays. Once data or instructions are read into the cache through the 64-bit-wide bus, they move around the chip internally on pathways as wide as 128 bits—and at transfer rates that are reportedly more than a billion bits per second. The caches are big enough (4K bytes for instructions, 8K bytes for data) that reasonably large loops (those that have up to 1000 instructions) will fit completely into the cache.

Parallel Processing and Pipelines

Another very sizable part of the 80860's speed comes from its parallel design. The new chip is designed to do three things at once: integer math, floating-point addition, and floating-point multiplication. This is possible because the chip's three math units are separate and can work on different problems at the same time.

In addition, each of the three math units is designed for pipelining. In most CPUs, each math instruction actually consists of a series of smaller, simpler operations. When most CPUs receive an instruction, they take a piece of data and perform each of these smaller operations separately on the data until the instruction is finished. The CPU then begins work on the next instruction and the next piece of data. By contrast, a pipelined system such as the 80860 is like an assembly line, with each of the smaller operations lined up in sequence on the production line.

As soon as the the first piece of data has completed the first stage of the assembly line, the CPU can start work on the second instruction and the second piece of data. Thus, even though an instruction may take dozens of clock cycles to complete, the 80860 can still produce one new result every clock cycle—from *each* of the math units. That means that, at 40 MHz, the 80860 can theoretically produce as many as 120 million results per second.

One problem with pipelining is that it requires that the CPU perform exactly the same operation on the data each time the pipeline is used. In other words, you cannot retool the assembly line. Another problem involves memory. Pipelining works effectively only when there is data in the data cache. This cache feeds the assembly line at much higher speeds than regular memory can.

The 80860's floating-point adder and multiplier can also be linked together for

vector operations. Indeed, Intel's designers say the 80860 is specifically modeled after Cray's vector-processing supercomputers. The company also claims that many of the vectorizing programming tools that were originally designed for the Cray will also be able to optimize 80860 software, but because the 80860 isn't limited to a vector register architecture, it is reportedly easier to program.

Graphics: Z-Buffers and Shading

To give the 80860 even more power, Intel filled one small hole in the chip with spe-

IBM and
Intel have already
shown an 80860 on
a PS/2 graphics card
that can probably
run rings around most
other workstations.

cial three-dimensional graphics hardware. This feature takes up only about one-thirtieth of the chip's area, but it provides special functions like z-buffering and Gouraud and Phong shading. Z-buffers store information on the third dimension of each pixel in an image and allow high-speed three-dimensional imaging.

The on-chip graphics processor makes sense for a chip that wants to do the work of a Cray, since a large proportion of supercomputing consists of graphics rendering. In fact, it is in a graphics coprocessor board that the 80860 will probably first appear as a product. IBM and Intel have already shown a PS/2 Micro Channel bus-master card built around the 80860 that can probably let a Model 80 run rings around most other workstations. Unfortunately, neither IBM nor Intel has indicated when the card will be available as a product.

It is easy to conclude that the chip might be confined to graphics workstations, but one Intel engineer pointed out that the company isn't just interested in the traditional workstation market. "We want to sell a lot of chips—a lot more than Sun sells workstations," he said.

The 80860 will go anywhere Intel can find a niche for it. It is designed to work easily in parallel with other 80860s, with existing 80386s, or with the forthcoming 80486s. It can work either as a coprocessor or as part of a multiprocessing system. That means it could work in the whole range of computer applications, from plug-in personal computer cards to minisupercomputers. Indeed, Intel says a minisupercomputer will be in beta test by the end of this year.

In June, a 33-MHz version of the first 80860 will become available. A 40-MHz version will be out by the end of the year, and the 50-MHz version should arrive in 1990. The 33-MHz version will be available in quantity for about \$750—roughly as expensive as an 8087 math coprocessor was in 1981. And as more 80860s are produced, the price will begin to drop. Within two or three years, the price of an 80860-based workstation should be well below \$10,000.

By then, there should be plenty of software to take advantage of the chip's power. Although the chip cannot directly run DOS or OS/2, it should be a powerful Unix engine. In fact, two separate versions of Unix are currently in the works—one from AT&T (System V release 4, which should be available by the end of the year) and a multiprocessor version from Olivetti. And although the 80860 cannot run OS/2 directly, Intel claims that there are already hooks in OS/2 to use the 80860 as a coprocessor. C, FORTRAN, and Pascal compilers are reportedly already available, along with math libraries for the functions that aren't provided on-chip.

Competition with the 80486?

Although Intel might sound as if it wants the new 80860 to become as ubiquitous as its popular 80x86 family, the new chip is not designed to replace the 80486 or its successors. In fact, the company made a point of saying that the 80486 would be officially announced around the time you read this. The two chips share much of the same technology, but the 80860 is the more ambitious of the two, aiming at supercomputing.

The 80860 is clearly a very exciting chip. Whether that will be enough to grab a big share of the graphics, workstation, and supercomputing market remains to be seen. But as it stands, it's the fastest thing on silicon—and the closest anyone's come yet to a Cray-on-a-chip. ■

Frank Hayes is a BYTE associate news editor based in San Francisco. He can be reached on BIX as "frankhayes."

We'll never try to sell you a laser printer.

We will, however, try to sell you on a laser printer language.

The PostScript® language from Adobe Systems.

You see, there are two kinds of printers and typesetters in the world. Those that support PostScript. And those that do not.

The ones that do—at last count there were 46—are completely compatible. That means, when you print a file on a PostScript printer from one manufacturer, you can print the same

file on a PostScript typesetter from a completely different manufacturer. And that's good to know, since more than 25 different O.E.M.'s have adopted the Adobe PostScript language.

On the other hand, when you print a file on a printer that doesn't support PostScript, that's virtually the only place you can print it. Forever.

Since there are so many different PostScript printers and typesetters, you can pick the one that

meets your specific needs. For paper handling options. Printing speeds. Choice of resolutions. And black & white or color output.

And only Adobe PostScript gives you absolute freedom to select the best hardware and more than 3,000 software programs for virtually every application, platform and budget.

Isn't it time you bought into the PostScript language?

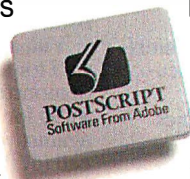

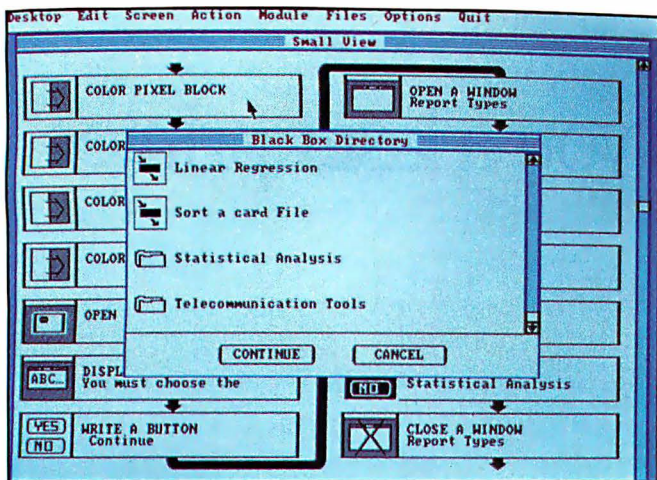

OOPS. Using sophisticated Object-Oriented Programming, Matrix Layout gives you the power to build complete applications faster than you thought possible. And that's just the beginning.

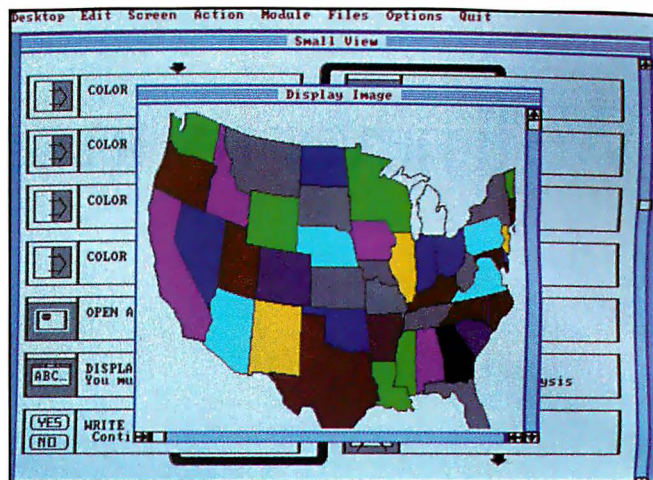

CASE. Layout's Computer Aided Software Engineering functions let you design programs using an intuitive flowchart model. Then, Layout can automatically turn your flowchart into source code or even an .EXE file.

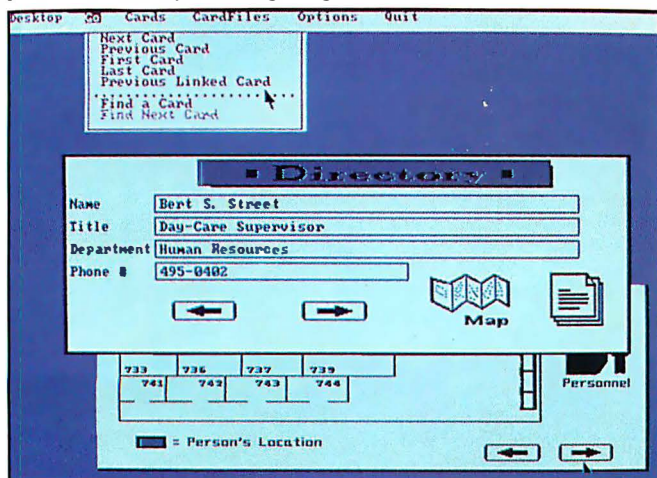

Hypertext. Layout puts all the features of Hypercard® on your PC and in your programs. Use Layout's graphical user interface to create documents with action links to related documents in any file. Or to create hyperlink applications.

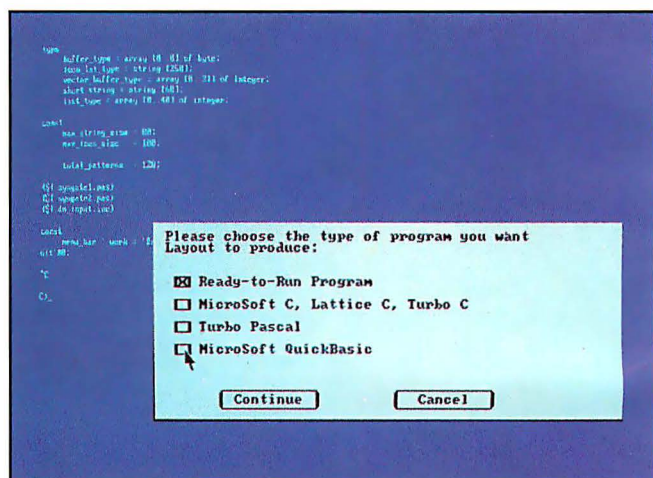

Plus, your favorite programming language(s). Using Layout's tools, you can cut your coding time up to 70 percent, and still produce ready-to-run programs in your choice of languages.

A Great Programming Tool Should Contain All Of The Above.

Presenting Matrix Layout, the first full software development system for the PC to promise you all the above. And deliver.

Sit down to Layout's intuitive user interface and in minutes you'll be using advanced OOPS (Object-Oriented Programming System) and CASE technology to build your program. Simply draw a flowchart indicating the windows, buttons, menus, text, and graphics you want.

A Cut Above Other Tools.

Layout also provides flowchart elements for Hypertext data base capabilities, math functions, variable management, conditional branching and looping. And, its open architecture allows you to build your own Black Box elements — to create exactly the program you want.

When your flowchart is ready, Layout uses

artificial intelligence technology to automatically turn it into code — Turbo Pascal, Turbo C, Microsoft C, QuickBasic or Lattice C. Or create a ready-to-run .EXE file right from within Layout.

It's so efficient, your programs will run incredibly fast, even on a standard 256K PC. Plus, they'll include Layout's automatic mouse support and device independence.

All The Above And More.

- Matrix Helpmaker helps you create context-sensitive help and complete on-line documentation for your programs.
- Matrix Paint offers a full set of graphics

tools, scanner support, and clip-art files to make your programs look professional.

- Finally, Matrix Desktop gives you a simple, visual way to organize files and disks.

For A Lot Below.

Layout delivers all the above for just \$149.95 — a lot below what you'd expect. Especially when you throw in free customer support, no copy protection, and a 30-day, money-back guarantee.

Video Tape Offer. Still not convinced? Call for a copy of our Matrix Layout VHS demonstration video at 1-800-533-5644 (just \$9.95 for shipping and handling, credited against your purchase). In Massachusetts, call (617) 567-0037.

Any way you look at it, Matrix Layout is the ultimate PC programmer's tool. And that's the bottom line.

M A T R I X
L A Y O U T

Matrix Software Technology Corporation • One Massachusetts Technology Center • Harborside Drive • Boston, MA 02128 • (617) 567-0037

Matrix Software/UK • Plymouth, England • 0752-796-363 • Matrix Software/Belgium • Geldenaaksebaan 476 • 3030 Leuven • 016202064
The following are registered and unregistered trademarks of the companies listed: Matrix Layout, Matrix Paint, Matrix Helpmaker, Matrix Desktop, Matrix Software Technology Corporation; Macintosh, Hypercard, Apple Computer, Inc.

Apple's New Compact Mac IIx

By chopping the number of expansion slots in half, Apple creates a sleek new version of its top-of-the-line Macintosh

In early March, Apple introduced yet another member of its growing family of Macintosh II computers. This new addition to the family is called the Mac IIcx, and, as you might be able to guess from the name, it is essentially a compact version of the Mac IIx.

It has a footprint of about 12 by 15 inches (see photo 1) and can sit either horizontally on the desktop or a bookcase, or vertically on the floor. The system's smaller size is made possible by having only three NuBus expansion slots instead of the six slots available in the Mac II and IIx.

Although smaller, the new Mac has the same 16-MHz 68030 processor as the Mac IIx and offers exactly the same performance. Additionally, its logic board (see photo 2) has the same circuitry as the IIx. This includes the new 256K-byte single in-line memory module (SIMM) ROM and the FDHD (for "floppy disk high-intensity") internal floppy disk drive controller that can read and write to MS-DOS, OS/2, and Apple II 3½-inch floppy disks.

One minor difference, unfortunately, is that the ROM SIMMs are soldered rather than removable as they are in the Mac IIx and SE/30. However, there are empty ROM sockets on the board for inserting new ROMs, should the need arise. Apple engineers told us that the ROMs were soldered simply to reduce the manufacturing cost.

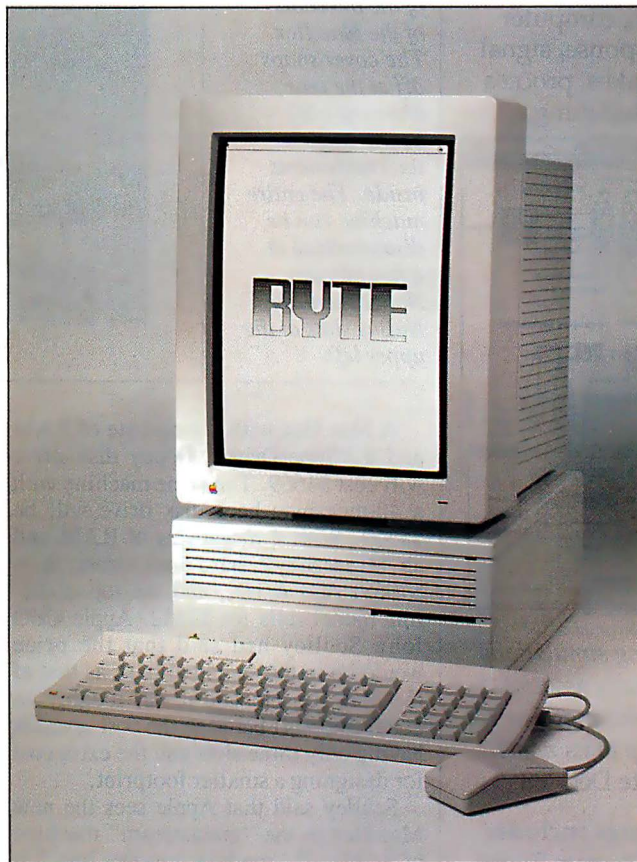

Photo 1: The Mac IIcx shown with the Apple Portrait Display. The reduced footprint covers an area of slightly more than a square foot. You can place the computer itself either horizontally or vertically.

What is interesting about the Mac IIcx is its physical design and modular construction, which remind me of the IBM PS/2 series. The cover, power supply, and drive housings all have snap fittings made of high-impact plastic. This allows you to disassemble the entire machine in a few minutes.

As mentioned earlier, the machine should be equally at home either on top of your desk or beside it. There are no vent slots on the sides or bottom of the unit that might be accidentally blocked. The unit even comes with removable feet and has a bezel on the rear that would allow you to insert the unit into a wall bracket (the bracket will be provided by

third-party suppliers).

The IIcx has a quiet 90-watt power supply (in contrast to the 220-W power supply on the Mac II and IIx) and two 3½-inch bays for a floppy disk drive and a hard disk drive (the Mac II and IIx have 5¼-inch bays, although they can also be used to carry 3½-inch drives).

Other new features include an external DB-19 serial port for connecting an external floppy disk drive and an auto-restart capability. The auto-restart causes the machine to automatically reboot itself in the event of a power outage. This feature makes it ideal for use as a network file server.

continued



Simulate with Extend™

Model electronic systems, cash flow, factory production, computer networks, neural response, signal processing, earthquakes, process control, material handling...

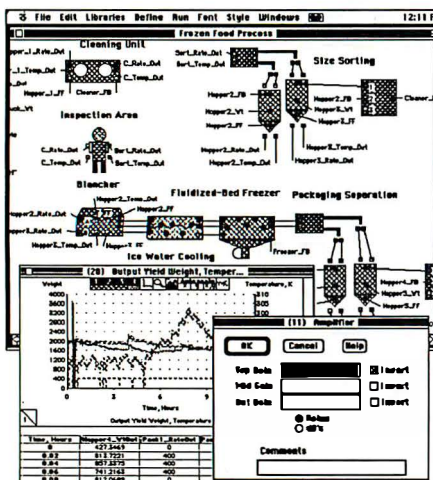

"... create some dazzling simulations without the pain normally associated with simulation programming. For my money, Extend lives up to its name."

- Don Crabb, Byte Dec. '88

Extend's unique features include:

- Continuous and Discrete Event
- Block diagram, library based
- Built-in programming language
- Custom dialog boxes and icons
- More than 150 built-in functions
- User defined functions
- File, Serial, Driver I/O
- Engineering libraries included
- \$495 for the Mac Plus, SE, II, IIX

Now Shipping Version 1.1!

Imagine That, Inc.

(408) 365-0305

7109 Via Carmela, San Jose CA 95139

Imagine That! and Extend are trademarks of Imagine That, Inc.

THE MAC IICX

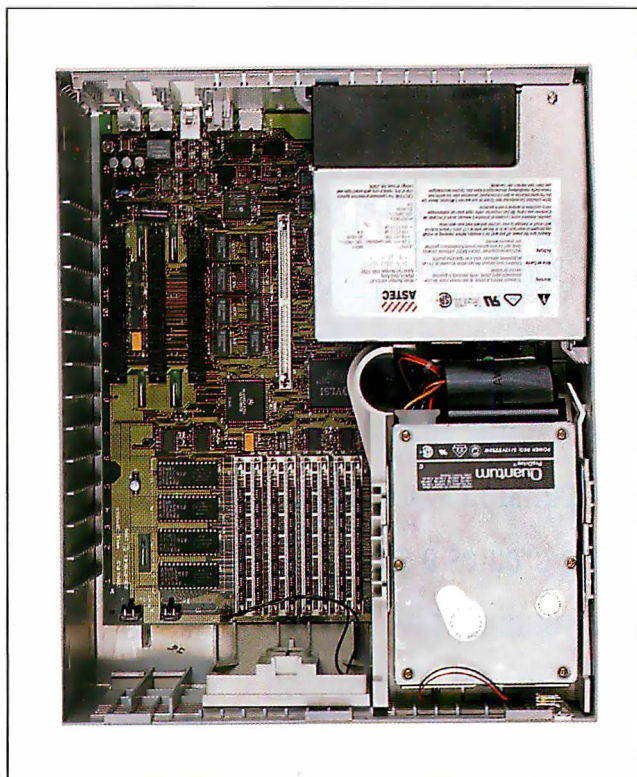

Photo 2:

An overhead view of the internals of the Mac IICX. The cover snaps off at the rear, allowing easy access to the components inside. The entire machine can be disassembled in a few minutes. Notice the three NuBus slots at the upper left.

A Mac IICX with 1 megabyte of RAM and a "SuperDrive" floppy disk drive will cost \$4669. The same machine with a 40-megabyte hard disk drive will be \$5369. With 4 megabytes of RAM and an 80-megabyte hard disk drive, it is \$7069. Add A/UX, and the top-of-the-line model sells for \$7552. Apple CEO John Sculley had said that the price would be in the same ballpark as that of the Mac IIx. He said it was roughly an equal trade-off between the cost saved in having only three slots and the extra cost for designing a smaller footprint.

Sculley said that Apple sees the new Mac IICX as the "mainstream" machine of its Mac II "modular product line." It is certainly the most physically appealing. Unless you need six expansion slots, the Mac IICX is a more practical package than the Mac IIx. It's quieter and takes up less room, but it's just as powerful.

New Monitors

Apple has also announced a new 15-inch portrait-oriented gray-scale monitor, the Apple Portrait Display (\$1099), which features 640-by-870-pixel resolution (80 dots per inch). The monitor requires the use of a Mac II Video Card Expansion kit (\$599), which can be configured with either 2-bit or 4-bit pixel depth (allowing display of four shades of gray).

The monitor is shown in photo 1 with the IICX. A nice feature of the Apple Por-

trait Display is that it has three Apple Desktop Bus connectors, so you can connect it directly to the keyboard, mouse, or other ADB device. This, along with the fact that Apple supplies a 6-foot cable for connection to the host computer, allows you to place the computer at a comfortable distance away.

The Portrait Display provides an excellent, crisp picture. It is ideal for word processing and desktop publishing.

In addition, Apple announced a new landscape-style 21-inch gray-scale monitor offering 1152-by-870-pixel resolution (with the standard 77 dpi). Called the Apple Two-Page Monochrome Monitor (\$2149), it also requires a special video card (\$599) that is slightly different from the card used with the Portrait Display. The Two-Page video card comes with 2-bit pixel depth, allowing two or four gray levels. An optional 4-bit-per-pixel upgrade (consisting of eight video RAM chips) allows display of 16 gray levels. Apple says the Two-Page Monitor will be available in May.

The new Apple products do not constitute a revolutionary change in the Macintosh world. However, they reinforce a sense of continued improvement in the Mac line, which is welcome indeed. ■

Nick Baran is a BYTE senior technical editor based in San Francisco. You can contact him on BIX as "nickbaran."

Produce Programs in a Flash

With Smalltalk-80, the Best in Object-Oriented Technology.

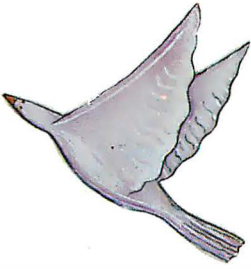

It's amazing.

In just a few years, object-oriented technology has become an overwhelming favorite. Witness the success of graphical user interfaces. But what's the best environment for developing these object-oriented programs?

Fortunately, that's no mystery. It's the Smalltalk-80™ program development environment from ParcPlace Systems. Pioneers of object-oriented technology.

We deliver the most complete, fully-integrated system available, with everything you need to quickly and easily develop and implement programs. Including a library of reusable code modules. Browsers, inspectors, and debuggers. Text and graphics editors. Online assistance. Dynamic cross referencing. And much more.

In fact, Smalltalk-80 is so comprehensive, Byte Magazine (1/89) felt compelled to rave, it "... includes everything you need for program development. Everything. And all the goodies are honest-to-God fully integrated."

Even better, Smalltalk-80 gives you true portability. Write programs on a UNIX® workstation and deliver them directly on DOS and MAC OS machines. Or vice versa.

To make sure you start fast and stay productive, we provide the best tech support in the business. Including training, documentation, a hotline, and more.

For details on Smalltalk-80, write:

ParcPlace Systems
1550 Plymouth Street
Mountain View, CA 94043

Call 1-800-822-7880, ext. 20; in California, 415-859-1000, ext. 20. Or use E-Mail. Our address: info@parcplace.com.

When you see what it can do, you won't believe your eyes.



ParcPlace

Smalltalk-80 is a trademark of ParcPlace Systems, Inc. UNIX is a registered trademark of AT&T. © 1989, ParcPlace Systems, Inc.

Circle 201 on Reader Service Card

MAY 1989 • BYTE 119

Benefit from breakthrough and experience

Complete* 6, 12, 16 and 20 MHZ Systems with

SIVA Systems from VNS America Corp. delivers the uncompromising power you want, plus the hardware/software products you need. Promptly. Courteously.

Enjoy the AT®-compatibility, speed and future upgradeability you would expect from up-to-date premium quality computers. And, enjoy the fast service so many have come to appreciate from VNS America Corp.

About VNS America Corp.

VNS America Corp. and its associate companies pool their expertise and buying power to bring you premium, name brand products at breakthrough prices.

We're bold, colorful and innovative. We have to be to gain your attention in this ultra-competitive industry. But, our products and service are first rate because we need your confidence to succeed.

IBM set the standard... we're just making it affordable to thousands of companies, individuals and industry that want quality at the best prices.

TRY US
Call 1-800-252-4212

VNS America Corp.

Suite 270, 910 Boston Post Road
Marlboro, Massachusetts 01752 U.S.A.
In Massachusetts 508-481-3726
FAX: 508-481-2218

The Powerful SIVA 386 System

Standard 386 Features:

- 32-bit Intel 80386-16 CPU.
- 1MB of 32-bit RAM on board. System expandable to 16MB.
- 16/20 MHz Keyboard selectable.
- ST-251-1 Seagate 40MB Formatted 28 ms high speed, with ultra high speed Controller 1:1 interleave.
- 1.2MB High Capacity Floppy Drive.
- Super deluxe heavy duty tower case with 5 half-height drive openings.
- High-resolution 12" Non-Glare Amber Display. Tilt and Swivel base, Hercules-compatible Adapter.
- EGA Controller Standard.
- 101 Key Enhanced Keyboard, Pleasant "Tactile-Click" Feel.
- 80287/387 Math-Coprocessors optional.
- Fully compatible with virtually all XT/AT and 386 software.

\$2495

Upgrades for your 386 System:

- VGA Color Upgrade — add only \$495.
- EGA Upgrade — add only \$295.
- 20 MHz CPU Upgrade — add only \$195.
- Call for all other options and upgrades.



pricing from VNS America™ unmatched performance!

Premium Name Brand Peripherals and Software!

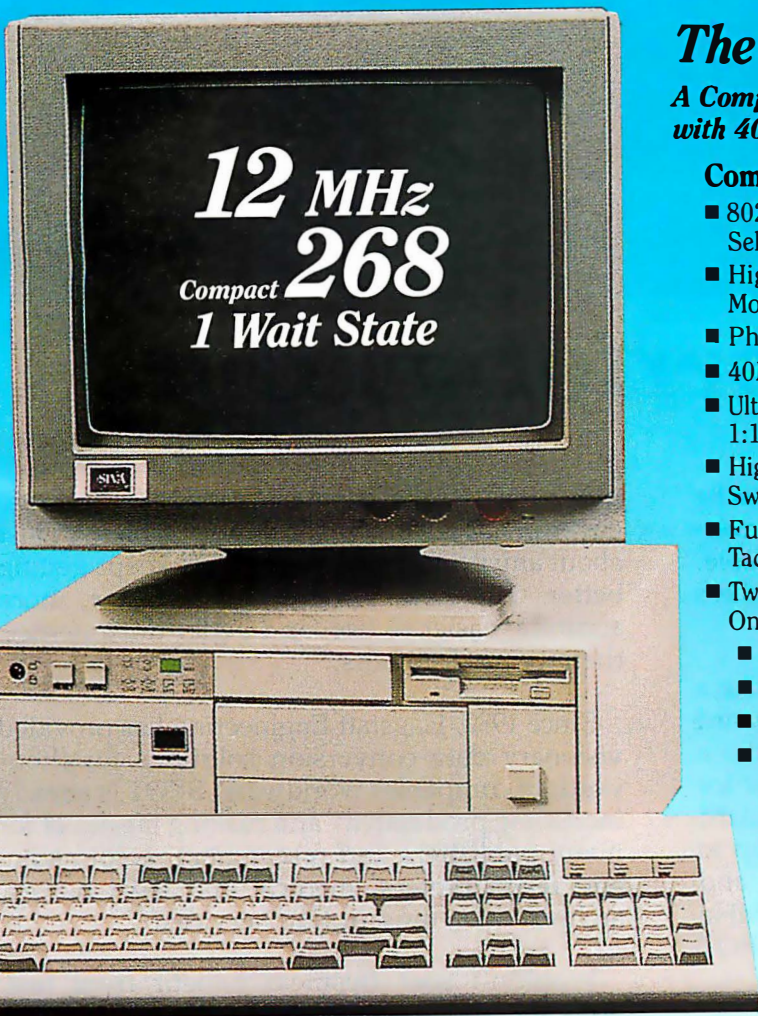

The Economical SIVA 286

**A Complete 12 MHz High-Speed SIVA 286 System
with 40MB (28MS-ST251-1) Hard Disk**

Complete System Features:

- 80286 CPU, 6/12.5 MHz Dual Speed, Keyboard Selectable
- High-Speed RAM, 512K Expandable to 4MB on the Motherboard (16MB System Total)
- Phoenix BIOS
- 40MB Hard Drive, 1.2MB Floppy Drive
- Ultra High-Speed Floppy, Hard Disk Controller 1:1 Interleave, 800KB/Sec Transfer Rate
- High Resolution 12" Amber Display with Tilt and Swivel Base, Compatible Graphics Controller
- Full 101-Key Enhanced Keyboard, Pleasant Tactile-Click Feel
- Two Serial and One Parallel Printer Ports and One Mouse Port (IBM PS/2 Compatible)
 - 3-16 Bit and 1-8 Bit Free Expansion Slots
 - Clock Calendar with 10-Year Life Battery Backup
 - 80287 Support, up to 10 MHz
 - Meets FCC Requirements

\$1295

Standard System Including all Standard Features except Hard Disk \$995

Lowest Cost Compilable Upgrader

- Additional 512K Memory for \$195.
- 1.5MB Additional Memory for \$395.
- EGA Upgrade for \$295.

Nine Reasons to Call VNS America Now...

- Produced by High Technology Manufacturing Processes
- FullySurface Mounted Technology
- EGA Controller Standard
- Supports 3.5" and 5.25" Floppy Disks
- 10-Year Battery Life
- Phoenix BIOS
- No Memory Surcharge (We're not opportunists!)
- Same Day Shipment (Competitors often take 4-6 weeks.)
- 100%-Compatible with Your Budget

**Complete: includes 12 MHz high-speed SIVA 286 System with 40 MB hard disk drive, monitor and keyboard.*

™ VNS America is a trademark of VNS America Corp.

Circle 283 on Reader Service Card

VNS America Corp.

**Order Now Toll-Free
1-800-252-4212**

**Complete unit includes CPU, monitor, keyboard and 40 MB hard disk drive.*

The Only Character Recognition System



That Outperforms Ours

Nature's character recognition system can be trained to read any language. Flagstaff Engineering's **SPOT OCR Text Reader** is also trainable. It has read text printed in thousands of typefaces in over 130 different languages!

The SPOT OCR Text Reader works just like a typist who reads a page, then uses a keyboard to transfer the information on the page into a computer file—except SPOT uses a scanner for eyes and outputs the text directly into standard text files. SPOT is also faster. It can read up to 35 characters per second on a 16MHz AT, and up to 65 characters per second on a 25MHz machine (that's 780 words per minute). SPOT supports most major makes of scanners.

Using sophisticated statistical techniques, SPOT recognizes characters like the brain does: by examining their shape and context. Like nature's original, SPOT is very flexible. It can glance over an entire page or zoom in on a few lines of text. SPOT can read newspapers,

magazines, books, manuals, invoices, contracts, government documents, columns, tables . . . just about any printed text. And SPOT keeps getting better. The **new Version 3.0** is faster, more accurate, easier to use, and better documented than its predecessors.

Since 1982, Flagstaff Engineering has provided visionary data conversion solutions for thousands of companies worldwide. SPOT is already increasing productivity and making life easier for many publishers and researchers, accountants and telemarketers, medical and legal offices, archival and transcription services.

Wouldn't *your* business benefit from fast, accurate, and low-cost OCR software? Give us a call and let our application specialists explain how you can save time and money with SPOT, *the* OCR text-entry solution.

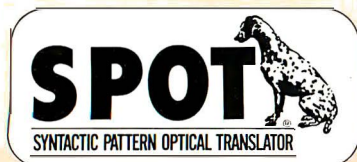

Join Flagstaff Engineering's
BIX conference: flageng

Circle 96 on Reader Service Card for
S.P.O.T. 3.0 Version
97 for 9 Track Tape
98 for Disk Conversion Systems Up-Date
99 for DEALERS only

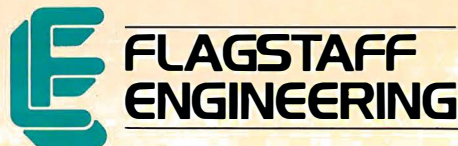

Helping People Read a World of Information

1120 Kaibab Lane • Flagstaff, AZ 86001
602-779-3341 • FAX 602-779-5998



SPRINGTIME RENEWAL

Jerry uses a “relentless application of logic” to convert an old program and rebuild an old computer

I had really intended to get this in early, but instead I’m late. No matter how fast I run, I seem always to be doomed to stay about three weeks behind. I do have reasons. . . .

What happened this time was a trip to Washington, DC, to help the Smithsonian Institution set up Zeke II. The old boy looked pretty happy in his new quarters in an attic of “the nation’s attic.” It’s getting crowded up there, but he had a table all to himself, and they seem to appreciate him.

He’s in the Museum of American History; if you haven’t been there, you should go. There are exhibits of everything from the original copy of “The Star-Spangled Banner” to technology, including bridge cable, early steam locomotives, and old typewriters. They haven’t yet set up the History of Computing section where they’re hoping to put Zeke, but that’s coming soon.

Another reason for my Washington trip was to present the SSX (Space Ship Experimental) briefing to the Office of Management and Budget and the Space Council. The SSX is, technically, a multi-engine, *savable* Single Stage to Orbit Vertical Takeoff and Landing Aerospike ship. What that means is that it flies up and down like the Apollo Lunar Module, but with this difference: if an engine goes out on takeoff, you can hover the ship, burn off the fuel, and land it again.

Several things make the SSX possible. One is new capabilities in airframe

structure. Another is small computers: while there will generally be a human commander aboard the SSX, the stick-and-rudder pilot will be a microcomputer. If you want a model of the SSX taking off, get a plastic bottle of soda water, empty half of it, and try to balance it on one finger as you push it rapidly toward the ceiling. It’s something a skilled human can just do—as long as there aren’t any strong winds and other distractions. Of course, it’s duck soup for a computer to control, wind or no wind. You could even write the control program in compiled BASIC, like Microsoft QuickBASIC 4.5.

The Citizens Advisory Council on National Space Policy is recommending the SSX as the low-cost way to get America moving in space again. Now if we can just get enough people behind it. . . .

Printer Problems

I’ve been making refinements in Mrs. Pournelle’s Reading Program while we look for a publisher. The program is now completely converted to QuickBASIC 4.5, and it runs like a charm.

I’m also converting my old accounting system. I use it because it’s still the only accounting system that makes your books look like the examples you see in Accounting 101 texts. The program handles everything: each month I type in the credit-card expenditures and bills—for regular bills, I have to put in only the amounts—and everything is written up into journals, with expenses allocated to their proper accounts (business or personal). Then it writes the checks. Before I wrote this system, tax time at Chaos Manor was sheer hell. It’s not all that easy now, but it’s sure better.

My accounting package was originally written for CP/M. The Golem, my big CompuPro 286, runs concurrent CP/M and has a Z80 slave board that runs the package (and all my other old CP/M programs). The problem is, last December the Golem went back up to CompuPro for

a full refurbishing, including conversion to the new CompuPro 386 cards. When he comes back, he’ll be awesome.

Alas, accounting and bill paying won’t wait. There was nothing for it: I had to get my accounting and check-writing system running on the Big Cheetah 386 under DOS. Worse, since I’d put things off, I had one evening to do it.

Still, it seemed simple enough: my son Alex long ago recompiled all those programs to run with DOS; they’re available from Workman & Associates. However, eons ago when I wrote those programs, I carefully formatted the output of the check-writing program and had checks printed; and in those days my main printer was a serial NEC Spinwriter.

Connecting serial printers is a black art. Among other things, you need a printer driver, which is a program that tells your computer what your printer expects; and I don’t have one for the NEC Spinwriter.

I don’t need one. My PCompatibles connect to printers through the Printer Optimizer, which is intelligent enough to accept standard parallel output from your computer and convert that to whatever protocol your printer expects. In other words, the Printer Optimizer is capable of being just about any printer driver you’d like it to be.

The Printer Optimizer is “programmed” in hardware; there’s a small gizmo like a miniature telephone switchboard that lets you connect up the output the way the printer expects and some DIP switches to let you set up communications protocols. This is all explained in the manual. Alas, although the NEC Spinwriter and my Hewlett-Packard LaserJet Plus are both serial printers, the Spinwriter expects an entirely different setup from the LaserJet Plus.

I could, of course, carefully record how things were set for the LaserJet Plus and then change the wiring to fit the Spinwriter, but I hate to take chances.

continued

SOLUTIONS

CHAOS MANOR

Bigger—

Vfeature Deluxe[™] lets your DOS system use hard disks it thought it couldn't, all in one bootable piece—no artificial partitions! You can even span your old drive with the new one for more capacity. Use RLL, ESDI, or SCSI, and laugh at DOS partition limits. \$120

DUB-14[™] takes a different approach to drive expansion, stretches your AT's Drive Table to support the drive *YOU* choose! Comes with setup and low-level format routines, and it's OS independent. \$95

Faster—

Vcache[™] accelerates disk operations, avoids repetitive accesses by storing data in RAM as you read it so it's there for you the next time you need it—no waiting! Works with any type of memory, caches up to 15 Mb, bundles accelerators for your diskettes, screens, and keyboard. \$59.95

Vopt[™] saves head motion by eliminating DOS file fragmentation. In a few seconds at boot time, *Vopt* arranges all your files neatly in contiguous clusters so you won't waste any time reading them back. Bundles timing and diagnostic utilities. \$59.95

Safer—

Vlock[™] protects your system and its data from vandals and accidents. System access passwords control booting, activity menus decide who does what to which files, even locks out Ctl-Break during boot! \$135

Easier—

Vtools[™] is a slick set of disk management tools for DOS and OS/2. Display directories in whatever order you like, browse files and change or delete them, compare and update multiple versions, find and manipulate categories of files, and more! \$49.95

SEE YOUR DEALER OR CALL TOLL-FREE

1 (800) 284-3269



GOLDEN BOW SYSTEMS
2870 5TH AVENUE
SAN DIEGO, CA 92103
(619) 298-9349

FAX (619) 298-9950 TELEX 201520 GBS UR
MC/VISA US shpg/hdlg \$3 CA orders add 7%

Vfeature, DUB14, Vcache, Vopt, Vlock and Vtools are trademarks of Golden Bow Systems.

While we do production printing on the big Kyocera F-3010 laser printer—like the upcoming *The Children's Hour*, a novella set in Larry Niven's shared-universe Man/Kzin War series—I do a lot of work with the LaserJet Plus.

Then I remembered: a year or so ago ACT sent me their new and updated Printer Optimizer, and I still have the old one I'd used for years. I *knew* it would run the Spinwriter because long ago it once had, even though it had since been reset to run the LaserJet Plus. There's hardly any memory in the old Printer Optimizer (that got sent back), but what the heck, a check-writing program doesn't need a lot of memory; I don't write *that* many checks each month.

It wasn't as easy as I thought it would be, because I've forgotten the Spinwriter settings. The Printer Optimizer manual has diagrams of how to set the switches and wire patches for nearly every conceivable printer; but I long ago misplaced the Spinwriter manuals, so I can't tell what its data transfer rate, parity, and other protocol settings are; and naturally this was in the middle of the night, so I couldn't call anyone who had the manuals. There are 36 ways the NEC might conceivably be set. I could see this might be a career.

Actually, it wasn't all that bad. I started with the suggested default settings from the Printer Optimizer manual, studied the switch settings on the Spinwriter, and tried to remember what we'd done back in the dark ages when that was my main printer. I thought I remembered that we'd set it on "Mark Parity," but the rest was a mystery. Time to experiment. Turn off the Printer Optimizer. Change a switch. Turn it back on. Go over to Big Cheetah, do Control-P, and type a letter. Nothing. Go back and try again. . . . On about the sixth try, I got a satisfactory click from the printer. After that, it was easy.

It's still not set absolutely right. I can print checks one at a time, but if I send over a number of them at once, I get data check errors. That means I've overrun the Spinwriter's buffer, and when it frantically tells the Printer Optimizer to stop sending data, the Printer Optimizer isn't listening because some switch is set wrong. By this time, it was late enough that I didn't care, and I printed one check at a time. Next month, I'll do it right.

QuickBASIC 4.5

It has been a long time since I wrote those accounting programs. CP/M has only 64K bytes of memory, limiting features and forcing me to use some very cryptic

commands. Now that memory isn't a problem, I could fix a lot of that.

Some of the programs were written in Microsoft BASCOM 1.0, but most are in CBASIC CB86. CBASIC still exists, but the publishers haven't made any improvements in years. However, Minnow Bear Computers makes a toolkit that keeps CBASIC relatively current; until Microsoft brought out version 4.0 of QuickBASIC, CBASIC CB86 with Minnow Bear CBC Tools was probably the best compiled BASIC in the world.

If you work with CBASIC, you should be aware of Minnow Bear; it's the only support for the language you're likely to get. Minnow Bear also publishes a program that will convert your CBASIC programs into C (Microsoft, Aztec, or Borland Turbo versions). However, I have no desire to learn C, which in my judgment is a fine language for full-time programmers, but not so hot for people like me who program in bits and pieces.

I'd like to move all those programs from BASCOM 1.0 and CBASIC CB86 to QuickBASIC 4.5. The problem is that QuickBASIC 4.5 has some bugs in its conversion system.

I found this out when I tried to read in ALLOC.BAS from the old BASCOM 1.0 code. ALLOC.BAS takes a journal in which you've entered items in any order you please (including stuff from previous years) and allocates all those entries to the right journals. It's useful because credit-card entries often don't get onto my bill for several months after the purchase was actually made.

BASCOM permitted you to have continued lines—that is,

```
INPUT # 1, A(1), A(2), A(3),  
A(4), A(5)
```

would read in the five variables in BASCOM; but when I read that line into QuickBASIC 4.5, all it saw was the first physical line and left the second line *blank*! It did that for nearly 40 entries scattered throughout the old code.

This was disconcerting to say the least; I spent half an hour cutting and pasting and generally getting the code entered properly. (That was the dumb way to do it, of course; what I should have done was use a programming editor to go through and concatenate all those continued lines. Ah, well.) Eventually, the program compiled, but it still didn't work, mostly due to problems with IF. . . THEN statements not properly terminated with END IF. It took another hour to track those down, but now I'm

continued

"TOPSPEED MODULA-2 IS A CLEAR WINNER!"

— Scott Robert Ladd, Computer Language



"Everything about this product exudes quality...it is one of the most complete and powerful development systems available today."

Scott Robert Ladd
Computer Language

"...TopSpeed™ is surely one of the finest new products introduced to date in the PC arena...DDJ doesn't give unqualified raves very often, but there's no question about it in this case; JPI's TopSpeed Modula-2 is first-rate."

Kent Porter
Dr. Dobbs Journal

"JPI Modula-2 looks like another classic in the making. It generates code as good as or better than leading C compilers and the programming environment is a genuine pleasure to use."

Dick Pountain
BYTE Magazine
Aug. '88, pg. 88IS-13

In England and Europe contact:
Jensen & Partners UK Ltd., 63 Clerkenwell Road, London EC1M 5NP. Phone: (01)253-4333.
DOS Compiler: £59.95, TechKit £34.95, VID £34.95, DOS 3-Pack £119.95, OS/2 Compiler £124.95.

Handling charges: In UK please phone for VAT & P&P. In Europe, add £6 for up to 3 products, £2 for each additional product.

Circle 141 on Reader Service Card

TopSpeed Modula-2 is a high-speed optimizing compiler (3,000-5,000 lines/min. on a PC AT 8MHz), integrated menu-driven environment with multi-window/multi-file editor, automatic *make*, fast smart linker. All Modula-2 sources to libraries included. **BONUS:** Complete high-speed window management module included with source. 258-page User's Manual and 190-page Language Tutorial.

OS/2 version now available: Runs in protected mode under OS/2 Standard or Extended Edition 1.0 or 1.1. Generates standard .OBJ files and .DLLs. Comes with fast, smart linker, built-in assembler. Modula-2 and assembly source code for libraries included (and fully compatible with DOS version). Full support of all OS/2 calls. Same integrated configurable environment as the DOS version.

VID (Visual Interactive Debugger): An integrated multi-window symbolic debugger for DOS. View source code as it executes. Single-step and trace through multiple modules. Qualify breakpoints with expressions. Examine & modify variables in symbolic form, including arrays, records & pointers. Automatic trace of variables accessed. Includes symbolic disassembler, execution profiler. 78-page manual. (DOS only)

The TechKit™ includes: Assembler source for start-up code and run-time library, JPI TopSpeed Assembler (30,000 lines/min.), TSR module, communications driver, PROM locator, dynamic overlays, and technical information. 72-page manual. (DOS only)

System Requirements: IBM PC or compatible, 384K available RAM, two floppy drives (hard disk recommended).



TopSpeed's seamlessly integrated environment.



VID (Visual Interactive Debugger): power without complexity.

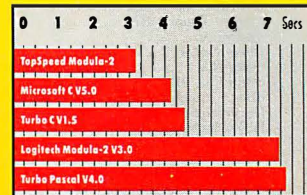

Sieve benchmark measured by the British Standards Institution (BSI) — 25 iterations on an 8MHz AT.

DOS Compiler \$99.95
TechKit \$59.95
VID \$59.95

DOS 3-Pack \$199.95
(Compiler, TechKit & VID)

OS/2 Compiler \$195.00

To Order:

In the US, call:
1-800-543-5202

In Canada, call:
1-800-543-8452

Or mail us your order with a check, money order, or VISA/MC information. 30-day unconditional money-back guarantee.

Shipping & handling charges:

In North America: add \$5 for each product ordered. CA residents please add applicable sales tax. Overseas: Add \$20 for EACH compiler and \$8 for each other product. 3-pack s & h is \$36.00.



Jensen &
Partners
International

1101 San Antonio Rd.
Suite 301
Mountain View, CA 94043
Phone: (415)967-3200

TopSpeed and TechKit are trademarks of Jensen & Partners International. Other brand and product names are trademarks or registered trademarks of their respective holders.

MAY 1989 • BYTE 125

THE PROGRAMMER'S SHOP

helps save time, money, and cut frustrations. Compare, evaluate, and find products.

FREE Latest Catalog

Over 900+ programmer's tools, including 100+ products for Dbase support and file management. Call today! **Mention BY589.**

New Discovery

Pro-C
by Vestronix generates commented, structured C source for screen programs, reports, menus, multi-file updates, system documentation, context-sensitive help. Runs under DOS, QNX, Xenix, Unix, Workbench provides source for 60+ library routines. No royalties. MS, Lattice, Zortech, Quick, Turbo C. \$459

Assemblers

| | List | Ours |
|--------------------------|------|------|
| MS Macro Asm | 150 | 105 |
| Turbo Assembler/Debugger | 150 | 115 |
| Visible Computer 80286 | 100 | 89 |

C Language - Compilers

| | List | Ours |
|--------------------------------|------|------|
| AZTEC C86 - Commercial | 499 | Call |
| High C-286 - by MetaWare | 595 | 549 |
| Instant C/16M | 795 | 699 |
| Lattice C - V3.4 | 450 | 289 |
| Microsoft C 5.1 - w/CodeView | 450 | 299 |
| Microsoft QuickC 2.0 | 99 | 75 |
| Turbo C - by Borland | 150 | 115 |
| Turbo C Professional | 250 | 179 |
| Watcom C6.5 - highly optimized | 295 | Call |

Dbase & Tools

| | List | Ours |
|------------------------------|------|------|
| Buzzwords Toolboxes | 295 | 249 |
| CLEAR+ for dBASE | 200 | 159 |
| Clipper Summer '87 | 695 | 469 |
| dBASE IV | 795 | Call |
| Dbase Online | 99 | 89 |
| dBMAN V | 190 | Call |
| dBRIEF w/BRIEF | 275 | 179 |
| dBug - source debugger | 195 | 179 |
| Documentor | 295 | 239 |
| DBXL Interpreter | 199 | 149 |
| FoxBASE+ - V2.1 | 395 | 259 |
| Genifer - code generator | 395 | 259 |
| R&R Relational Report Writer | 149 | 139 |
| SoftCode w/dBASE templates | 80 | 69 |
| Quicksilver Diamond | 599 | 369 |
| UI Programmer | 295 | 239 |

Debuggers

| | List | Ours |
|--------------------------------|------|------|
| Periscope II - breakout switch | 175 | 139 |
| Periscope III - 10 MHz version | 1395 | 1119 |
| SoftProbe II TX - debug | 395 | 345 |
| Sourcer | 100 | 89 |

Editors

| | List | Ours |
|-------------------------|------|------|
| BRIEF | 195 | Call |
| COMPEDITOR | 175 | 165 |
| Edix | 195 | 159 |
| Epsilon - like EMACS | 195 | 169 |
| KEDIT - like XEDIT, V.4 | 150 | 125 |
| Personal Rexx | 150 | 139 |
| MKS VI | 149 | 129 |
| PI Editor | 195 | Call |
| SPF/PC - V2.0 | 245 | 185 |
| Vedit Plus | 185 | 129 |

Text Screen Addons

| | List | Ours |
|------------------------------|------|------|
| AEWindows | 225 | 139 |
| C Windows Toolkit | 100 | 95 |
| C Worthy w/forms | 295 | Call |
| C-scape | 399 | 379 |
| Curses - by Aspen Scientific | 159 | 109 |
| with source | 289 | 279 |
| Greenleaf DataWindows | 295 | 219 |
| JAM by JYACC | 750 | 679 |
| Vitamin C - source, menus | 225 | 169 |
| Vermont Views - replaces WFD | 395 | 349 |
| with source | 790 | 659 |

Note: Mention this ad. Some prices are specials. Ask about COD and POs. Formats 3" laptop now available, plus 200 others. UPS surface shipping add \$4/per normal item. All prices subject to change without notice.

Established 1983. We carry over 1,100 different products. Call today for complete technical information and advice, our catalog, literature, and solid value.

5-B Pond Park Road
Hingham, MA 02043
Mass: 800-421-8006
or 617-740-2510 3/89
Telex: 071-5348
FAX: 749-2081

800-421-8006

HOURS:
M-F 8:30 - 8:00
Sat. 10:00 - 4:00

happily adding features to ALLOC.BAS.

Next, I want to convert the other files from CBASIC. Of course, CBASIC also allows continuation lines, and I used a lot of them. Fortunately, they're all marked by a slash at their end, so I suppose it will be possible to search through the sources with the Norton Editor and close all those lines up. It will also be a fair degree of bother; and CBASIC uses multi-line functions in quite a different manner from QuickBASIC 4.5. That conversion isn't going to be easy.

Of course, it's hardly Microsoft's fault that converting from CBASIC is work; but I do wish they had some mechanism for continuing lines. If you must put everything on one line, the source code gets very long and very ugly, nearly impossible to read, much less print out in a decently structured format. Sometimes it's no problem to code in short lines, but once in a while there are disadvantages. In the example above, I'd have to do

```
INPUT # 1, A(1), A(2), A(3)
INPUT # 1, A(4), A(5)
```

which works, of course, but unless the compiler is smarter than I think it is, it's going to be somewhat slower. Maybe the thing to do is to debug everything in the readable format, then take out the continuations just before the final compile.

I understand that Microsoft has moved QuickBASIC from the languages group over to consumer products. I hope that doesn't mean they think the language is finished. There are a number of things it needs, starting with some mechanism for continuing lines. They can also fix some overflow bugs: even in version 4.5, there are programs that will run in the interpreted mode but blow up when compiled. (In fairness, most—nearly all in fact—of those problems seem to be peculiar to 80386 machines with an 80387 math chip.) I'd also very much like to see a compiler toggle that complains if you try to run with undeclared variables.

Then they can make some improvements in their code generator. That's no easy task, given all the features of QuickBASIC 4.5 with its on-line context-sensitive help (which can often be more useful than the rather oddly organized documents). I suspect the proper way to reduce the size and generally speed up Microsoft QuickBASIC code would be to write a second compiler whose input is code already known to compile and run; perhaps *already compiled* code, the output of the present compiler. That second compiler wouldn't need so many debug-

continued

Infinitor™

PROGRAMMABLE EDITOR

Introducing the editor that's as good as you are

Infinitor puts new creative power in your hands and opens up editing possibilities ad infinitum.

Infinitor's powerful TPL™ Text Processing Language lets you emulate EMACS, VI or your favorite editor. Perform complex text processing functions. Compile while inside the editor. And create your own on-line references and commands.

Its Nimble Windows™ lets you edit 10 files at once without shuffling between files. You can select, size, position and split windows at a keystroke.

You also get unlimited file size, re-configurable keyboard, auto indent, block manipulation, search and replace, restore line, on-line help and more. All for \$150, with a money-back guarantee.

Isn't it time you had the editor that's as good as you are? Order now.

1-800-526-5368



AGRANAT SYSTEMS
PO Box 4415
Brockton, MA 02401-4415

For IBM PCs or compatibles with 384K or more, 5.25 inch format.

THE NEW STANDARD FOR HIGH PERFORMANCE STATISTICAL SOFTWARE

CSS

**COMPLETE STATISTICAL SYSTEM
WITH DATA BASE MANAGEMENT
AND GRAPHICS**

A powerful, comprehensive, elegant, and super-fast statistical package for IBM (PC, AT, PS/2) and compatible computers. ■ The CSS optimized user interface with fast hierarchical menus incorporates elements of artificial intelligence; even complex analyses require only a few keystrokes (batch processing is also supported). ■ CSS features comprehensive, state-of-the-art implementations of: *Basic statistics, Multi-way frequency tables, Nonparametric statistics, Exploratory data analysis with analytic graphs, Multiple regression methods, Time series analysis with modeling and forecasting (incl. full ARIMA), General ANOVA/ANCOVA/MANOVA, Contrast analysis, Discriminant function analysis, Factor analysis, Principal components, Multidimensional scaling, Item analysis/Reliability, Log-linear analysis, Cluster analysis, Non-linear estimation, Logit/Probit analysis, Canonical analysis, Survival and Failure Time analysis (Censored data), Quality Control analysis, and much more.* ■ All statistical procedures are integrated with fast data base management and instant, presentation quality graphics (over 100 types); full support for all mono and color graphics boards (incl. VGA) and over 100 plotters and printers (incl. the HP and Postscript standards). ■ All CSS screen output is displayed via customized Scrollsheets™ (i.e., dynamic, user controlled, multi-layered tables with cells expandable into pop-up windows); all numbers in a Scrollsheet™ can be instantly converted into a variety of presentation quality graphs; contents of different Scrollsheets™ can be instantly aggregated, combined, compared, plotted, printed, or saved. ■ The flexibility of the CSS input/output is practically unlimited: CSS offers an intelligent interface (read/write) to all common file formats (Lotus, Symphony, dBase, dBase III+, dBase IV, SYLK, ...) and special utilities to easily access data from incompatible programs; graphics can be saved in files compatible with desktop publishing programs (Aldus, Ventura). ■ CSS data files can be as large as your operating system (DOS) allows; OS/2 version coming soon. ■ CSS precision exceeds the standards of all common precision benchmarks. ■ *Technical note: The CSS user interface and all I/O were written in Assembler and bypass DOS; graphics and data management were written in Assembler and C; the computational algorithms were written in Assembler and optimized Fortran.* ■ \$495 (plus \$5 sh/h); 14-day money back guarantee.

Circle 252 on Reader Service Card



StatSoft

2325 East 13th Street ■ Tulsa, OK 74104 ■ (918) 583-4149

Fax: (918) 583-4376

Overseas Offices: StatSoft of Europe (Hamburg, FRG), ph: 040/4200347, StatSoft UK (London, UK), ph: 0438/310056 or 316561, StatSoft Pacific (Melbourne, Australia), ph: 613-663-6580

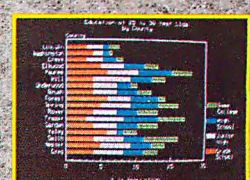
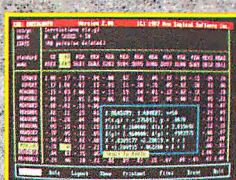
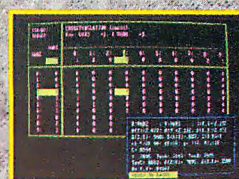
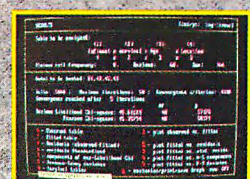
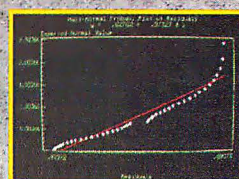
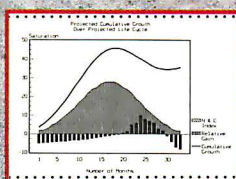
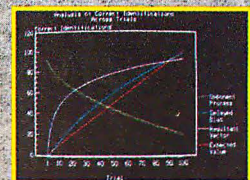
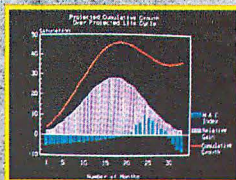
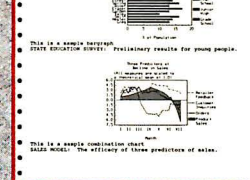
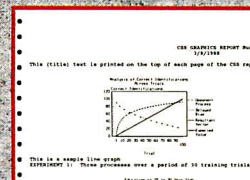
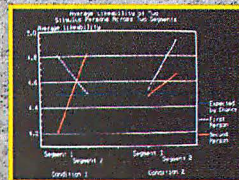
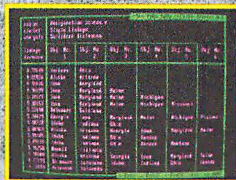
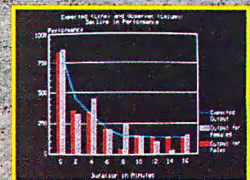
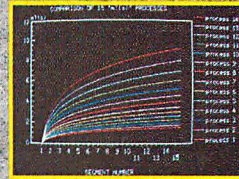
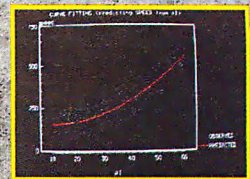
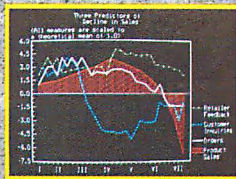

ging features, nor would it have to do so much error checking.

For all that, I'm getting quite fond of QuickBASIC 4.5, and I continue to work with it.

QuickBASIC Tools

I have two major packages of QuickBASIC tools: QuickPak Professional from Crescent Software and ProBas (Professional BASIC Programming Library) from Hammerly Computer Ser-

vices. They're both quite useful. Each company has additional toolkits: Hammerly has the ProBas Toolkit, which takes the stuff in their first kit and combines it into a number of complex programs, while Crescent has a Graphics Pak. Alas, what with everything else this month, I didn't get much chance to look at the advanced packages, but I have worked with the QuickBASIC tools.

Comparing these toolkits isn't easy; each has features the other lacks. If I had

to buy just one, I'd get the Crescent package for two reasons: first, it contains more assembly language functions that can be manipulated by name in QuickBASIC 4.x and higher. For example, something very useful in both packages is a way to determine if a file exists without having to use the ON ERROR GOTO error trap. (Error traps add a lot to code size and complexity; while they're useful as diagnostics and debugging aids as you build the program, it's far better to do without them in the final version.) ProBas does that this way:

```
CALL EXIST (Filename$, Found%)
IF Found% THEN PRINT Filename$,
"exists."
```

QuickPak accomplishes the same job with:

```
IF EXIST(Filename$) THEN PRINT
Filename$; " exists."
```

There are many other such instances. Clearly, the QuickPak way is simpler. Of course, only QuickBASIC version 4.0 and above work that way; for earlier versions, QuickPak has to use the same method ProBas does.

The other reason I mildly prefer QuickPak is that it has more higher-level routines, such as menu construction, which are available only in the extra-cost ProBas Toolkit. In contrast, there are more functions in ProBas.

There's considerable overlap in the two toolkits. They both let you add mice to your programs. Both have editing functions, screen managers, and the like. However, the overlap is not 100 percent, and each package contains some useful stuff that the other doesn't have. Anyone doing serious QuickBASIC programming would do well to get both, and either one is worth having.

Project X Dies

Shortly after my problems with their copy routine—see last month's column—Project X Software vanished: their telephones were disconnected, and mail is returned unopened.

In a way, that's a pity. Both Crescent and Hammerly have stated that Project X made rather free with other people's code, which is a pretty serious charge; and I certainly had enough trouble with their DOS routines. On the other hand, they also had some features, such as dialog boxes, that were pretty nifty and not available in the other toolkits.

There's not much to be done about
continued

ARE YOU STILL DRAWING FLOWCHARTS BY HAND?

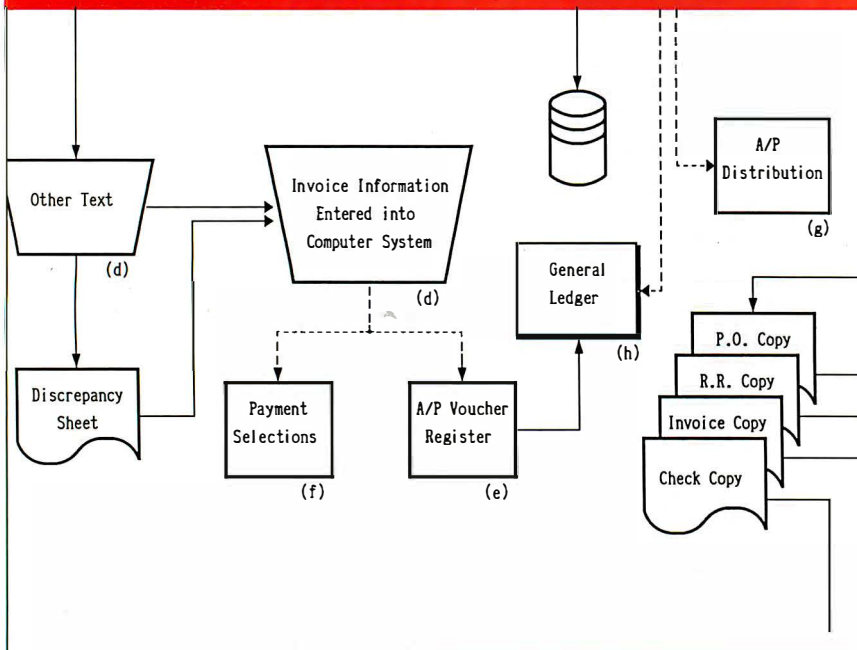

FLOW CHARTING II+

Flow Charting II+ will *amaze* you with its speed, power and simplicity.

- Update and print charts as fast as the situation changes
- See your revisions right away—no long wait for charts to be hand drawn
- Select 26 standard shapes; 10 text fonts
- Tutorial manual makes learning easy
- Runs on IBM or compatibles
- Produces excellent organizational charts!
- Only \$229!

PATTON & PATTON

Software Corporation

Excellence in charting the flow of ideas

For more information, see your local retailer or call
1-800-525-0082, ext. 47 (outside Calif.) 408-629-5376 (Calif./Int'l.)
81 Great Oaks Blvd., San Jose, CA 95119

3 books for only \$1.95



and get **FREE!**
dBASE IV™ Essentials

YES! Please accept my membership in the *Computer Professionals' Book Society* and send me the volumes I have listed below, plus my free copy of dBASE IV Essentials (3116P), billing me only \$1.95 plus shipping and handling charges. I understand that the books are sent on a 10-Day Free

Examination basis. If dissatisfied in any way, I may return the books within 10 days and incur no further obligation. Otherwise, I agree to pay the enclosed invoice promptly and to receive regular club bulletins as described in "How the Club Works." To complete my membership obligation I need only purchase 3 additional books at regular members prices during the next 2 years, and may resign at any time thereafter.

NAME _____

NAME OF FIRM _____
(If you want Society Bulletins sent to your office)

ADDRESS _____

CITY _____ STATE _____ ZIP _____

SIGNATURE _____

Valid for new members only. Foreign applicants will receive special ordering instructions. Canada *must* remit in U.S. funds. This order is subject to acceptance by the *Computer Professionals' Book Society*. BYP589



3 books for only \$1.95



and get **FREE!**
dBASE IV™ Essentials

YES! Please accept my membership in the *Computer Professionals' Book Society* and send me the volumes I have listed below, plus my free copy of dBASE IV Essentials (3116P), billing me only \$1.95 plus shipping and handling charges. I understand that the books are sent on a 10-Day Free

Examination basis. If dissatisfied in any way, I may return the books within 10 days and incur no further obligation. Otherwise, I agree to pay the enclosed invoice promptly and to receive regular club bulletins as described in "How the Club Works." To complete my membership obligation I need only purchase 3 additional books at regular members prices during the next 2 years, and may resign at any time thereafter.

NAME _____

NAME OF FIRM _____
(If you want Society Bulletins sent to your office)

ADDRESS _____

CITY _____ STATE _____ ZIP _____

SIGNATURE _____

Valid for new members only. Foreign applicants will receive special ordering instructions. Canada *must* remit in U.S. funds. This order is subject to acceptance by the *Computer Professionals' Book Society*. BYP589





NO POSTAGE
NECESSARY
IF MAILED
IN THE
UNITED STATES

BUSINESS REPLY MAIL

FIRST CLASS PERMIT NO. 9 BLUE RIDGE SUMMIT, PA 17214

POSTAGE WILL BE PAID BY ADDRESSEE

Computer Professionals'

Book Society

Blue Ridge Summit, PA 17214-9988

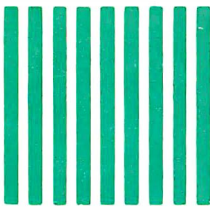

NO POSTAGE
NECESSARY
IF MAILED
IN THE
UNITED STATES

BUSINESS REPLY MAIL

FIRST CLASS PERMIT NO. 9 BLUE RIDGE SUMMIT, PA 17214

POSTAGE WILL BE PAID BY ADDRESSEE

Computer Professionals'

Book Society

Blue Ridge Summit, PA 17214-9988

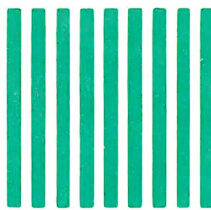

THE COMPUTER PROFESSIONALS' BOOK SOCIETY

The easy, reliable way to satisfy your professional book needs . . .

3 books for only \$1⁹⁵ (Values to \$195.80)

and get **dBASE IV™ Essentials** FREE!

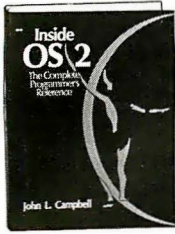

3019 \$39.95
Counts as 2

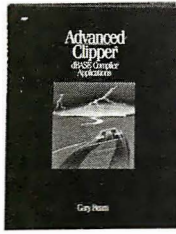

3007P \$17.95

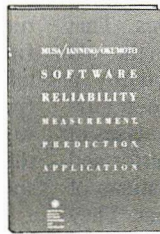

9824 \$49.95



9815 \$38.95



9829 \$45.00

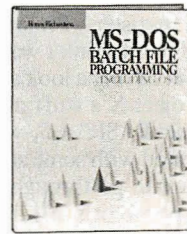

3028 \$27.95

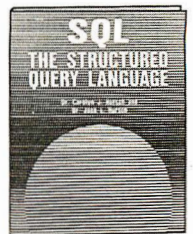

3016P \$17.95



2838 \$19.95

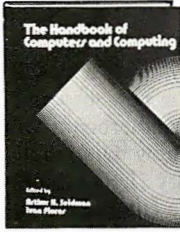

9785 \$86.95

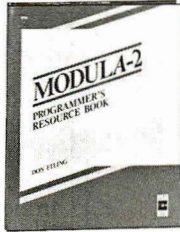

2741P \$19.95

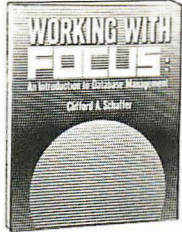

2810P \$22.95

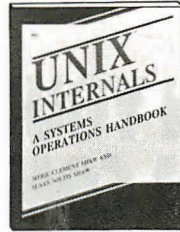

2951P \$18.95

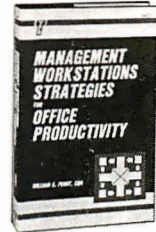

2833 \$21.95

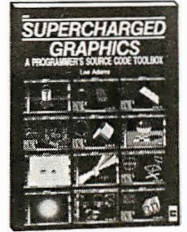

2959P \$19.95

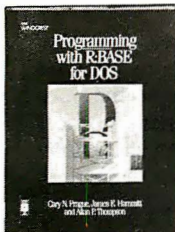

3196P \$24.95



2897 \$27.95

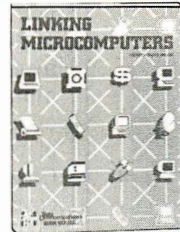

9798P \$29.95

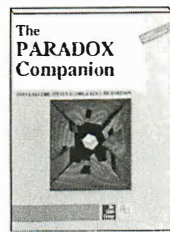

9810P \$24.95

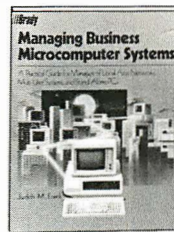

9764P \$19.95

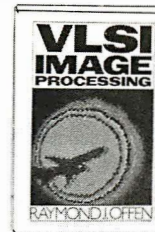

9832 \$36.95



3047 \$34.95

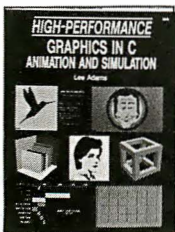
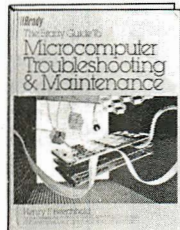
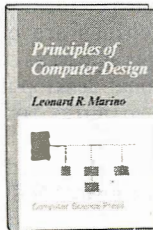

3049P \$26.95

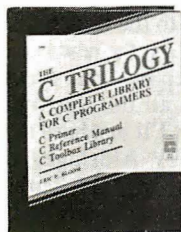

2890 \$34.95



9808 \$34.95

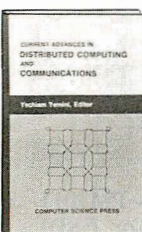

9777 \$49.95

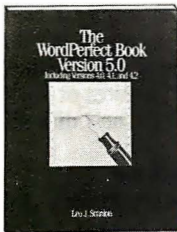

3127P \$16.95



2888 \$32.95

All books are hardcover unless numbers are followed by a "P" for paperback.
©1989 Computer Professionals' Book Society, Blue Ridge Summit, PA 17234-0870

FREE when you join the



dBASE IV™ Essentials

A unique and timely discussion of all the new programming features offered by dBASE IV™ —including both SQL and QBE.

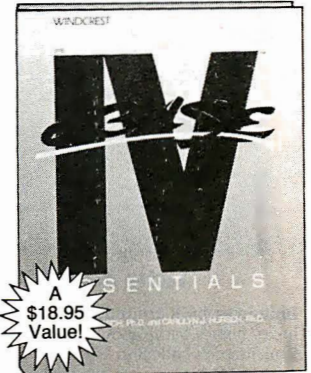

A \$18.95 Value!

How the Club Works

YOUR BENEFITS: You get 3 books for \$1.95 plus shipping and handling when you join. You keep on saving with discounts up to 50% off as a member.

YOUR PROFESSIONAL BOOKSTORE BY MAIL: Every 3-4 weeks, you will receive the Computer Professionals' Book Society News describing the Main Selection and Alternates, as well as bonus offers and special sales, with scores of titles to choose from.

AUTOMATIC ORDER: If you want the Main Selection, do nothing and it will be sent to you automatically. If you prefer another selection, or no selection at all, simply indicate your choice on the reply form provided. As a member, you agree to purchase at least 3 books within the next 2 years and may resign at any time thereafter.

BONUS BOOKS: Starting immediately, you will be eligible for our *Bonus Book Plan*, with savings of up to 80% off publishers' prices.

IRONCLAD NO-RISK GUARANTEE: If not satisfied with your books, return them within 10 days without obligation!

EXCEPTIONAL QUALITY: All books are quality publishers' editions especially selected by our Editorial Board.

BYP589

that, of course. Although Crescent will send you the source code to their assembly language routines—you have to request it when you register—Project X didn't do that, and I don't think I want to try their code without having a look at the source. Much of Project X's stuff didn't quite work with QuickBASIC 4.5, while the rest has to be viewed with some suspicion; I wouldn't want to go through last month again. I suppose it's all moot anyway.

Jazzing Up Big Cheetah

The conventional wisdom is that computers are plenty fast enough; what slows things down are disk operations. That was certainly true enough in the old days. It may not be so now. Certainly, a number of colleagues have been surprised when they did careful analyses of what operations were being performed during long compiles, recalculations of spreadsheets, and things like that. They found that more often than not, the sys-

tems were compute-bound rather than I/O-bound.

On the other hand, machines are getting faster. My Big Cheetah 386 can run fine at 25 MHz, and the people at Cheetah are anxiously awaiting 33-MHz chips from Intel. The Cheetah board should work with those at full speed, and that, they think, should definitely put the speed limits back in disk operations.

In anticipation of the event, they've been experimenting with new disk controllers. Last week, Cheetah sent Larry Aldridge, from Sterling Solutions (1824 Starfire Ave., Corona, CA 91719, (714) 371-1767), with a whole batch of new goodies: a new power supply, a new Cheetah motherboard with new ROMs, and the new Distributed Processing Technology (DPT) intelligent disk controller. We figured it would take about 4 hours to install the works. Of course, nothing goes the way you think it will...

Big Cheetah is a tower machine. This means that when you want to work on him, you can either get down on the floor or lift him onto a workbench. In most places that would be no trouble, but in Chaos Manor, finding a workbench not covered to three layers isn't easy. Eventually, I cleared off a cart and we took Big Cheetah apart.

Once you get them up on the table, tower machines are quite open, and everything is at least as easy to get at as in a conventional desktop machine. It took about 20 minutes to change power supplies.

The new one is called the Turbo Cool 250 and comes from P.C. Power & Cooling. It delivers 250 watts of power (formerly 200). It also puts out considerably more air—and thus more noise. Compared to the 8-inch disk drives I endured for years, the new fan is as quiet as a field mouse; but you certainly can hear it. Given all the electronics we installed, I expect I'll just have to get used to it.

Larry Aldridge, who studies these things, says the Turbo Cool 250 is the best power supply on the market. It runs cooler, and there's more power filtering than in the standard power box. Since the best power supply doesn't cost a lot more than the cheapest, it's foolish to stint.

Changing the motherboard took another 20 minutes or so. Then it was time to install the new disk controller.

Frustrations

The new controller is DPT's PM3011 Caching Disk Controller for ESDI drives. Cheetah's Gene Sumrall con-

continued

WHY DESIGN YOUR PRODUCT AROUND A COMPUTER?

Design the computer in.

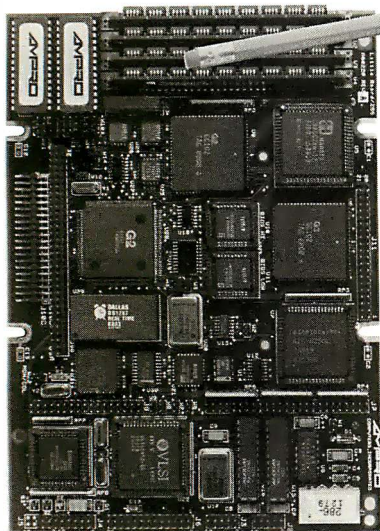

Little Board™/286

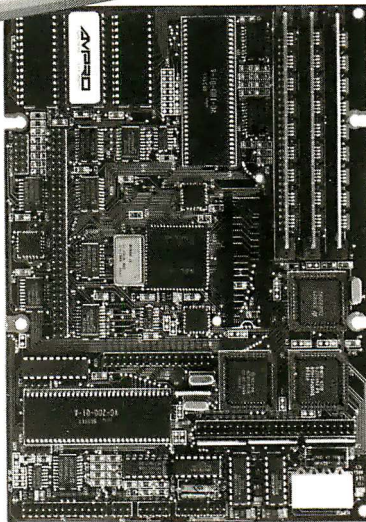

Little Board/PC

Built-in vs. built-around. External systems mean boxes, boards, backplanes, cables, and reliability problems. Ampro's Little Boards give you a complete system on a single board you can build right into your product.

Small size. Big power. Eliminate the bulk and constraints of multi-board, backplane-based systems. Embed a Little Board that requires just 2/3rds the power and volume of a 5 1/4" floppy drive. But with the full power of a PC or AT®.

Fully compatible. Little Board/286 and Little Board/PC are functionally identical to multi-board PCs and ATs. They run PC-DOS™ 2.0 to 3.X. They run DOS languages, compilers and applications. You'll be standing on a proven foundation of hardware and software.

Ampro's Single Board Systems. It's all there. Up to a Megabyte of RAM. RS-232C and Parallel ports. AT/PC-compatible controllers and bus expansion. EGA/CGA/MDA and Hercules™.

compatible video options. Even optional solid-state disk. Plus SCSI support for hard disk, tape, optical drives, bubble drives... you name it. And, low power consumption (+5VDC, less than 8W) and a wide operating temperature range (0 to 60°C). Perfect for standalone operation and harsh environments.

Anywhere that reliability is a critical consideration. Available worldwide. For information and the name of your nearest U.S. or international Ampro representative, call us at the number below. Or write for Little Board Product information.

Now includes DR-DOS™

408-734-2800

Fax: 408-734-2939 TLX: 4940302

AMPRO

COMPUTERS, INCORPORATED

1130 Mountain View/Alviso Road
Sunnyvale, CA 94089

Reps: Australia—61 3 720-3298; Austria—43-222/45 45 01; Canada—(604) 438-0028; Denmark—45 3 66 20 20; Finland—358 0 585-322; France—331 4502-1800; Germany, West—49 89 611-6151; Israel—972 3 49-16-95; Italy—39 6 811-9406; Japan—81 3 257-2630; Netherlands—010-411 85 20; Spain—M34 3204-2099; Sweden—46 8 55-00-65; Switzerland—41 1 740-41-05; United Kingdom—44 2 964-35511; USA—contact AMPRO

Trademarks: IBM, AT—IBM Corp.; Hercules—Hercules Computer Technology, Inc.; Little Board—Ampro Computers, Inc.; DR-DOS—Digital Research, Inc.

MAXXICAD

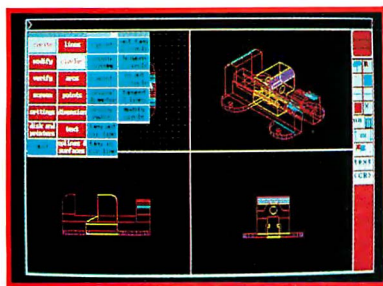
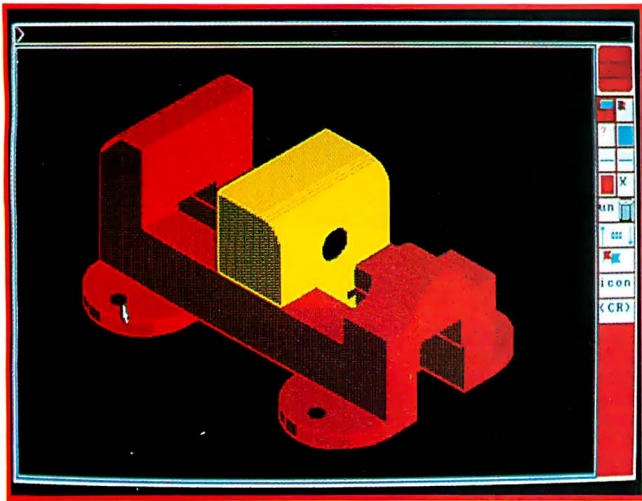
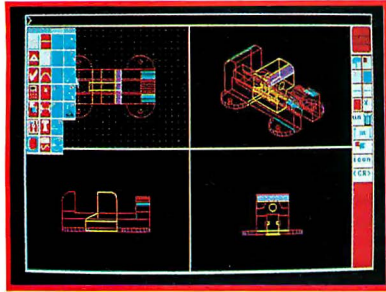
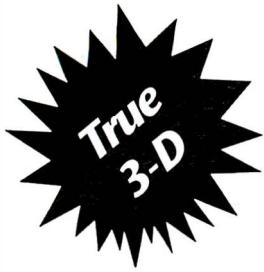

- Model mode (3D) or picture mode (2D) selectable at any time
- Optional "pop-up" icon or text command structure
- A dynamic on screen example available for each of 200+ commands
- Displays up to 14 active views simultaneously
- Dynamic rotation and translation of views
- Modification of entities
- Complex surfaces
- Dimensioning and tolerancing includes 18 options
- Multiple utility commands available during sessions
- Efficient file storage, security, back-up and recovery
- Three levels of documentation
- 24 hour telephone availability

"Maxxicadd stands as one of the most promising CAD products in today's market."

"Maxxicadd's remarkably simple user interface and on-line animated help facility is a dealer's dream come true. Within a day, any dealer (or, for that matter, user) can learn enough of the package to be giving demonstrations."

- Reprinted from Computer Graphics Today, August, 1988

"Engineering Tools For The Twenty First Century"



CRTC

COMPUTER RESOURCE TECHNOLOGY CORP.

2164 East Broadway Road, Suite 310

Tempe, Arizona 85282

(602) 921-9638

Call toll-free for more information and a demonstration disk.

1(800)544-0746, Ext. 923

Aw...What the Heck!

EXTREMELY POWERFUL

DesignCAD 3-D version 2.0 is as powerful as most CAD systems costing \$5000-\$10,000! Features like: Complex Extrusions-linear, scalar, and circular, Blending of Surfaces, Shading, Cross Sectioning, Complex Sweeps and Translations, and Boolean operations make DesignCAD 3-D one of the most powerful 3-D CAD systems available... at any price! Engineers, Architects and Consultants constantly tell us that they use CAD systems costing thousands of dollars which are not as powerful as DesignCAD 3-D.

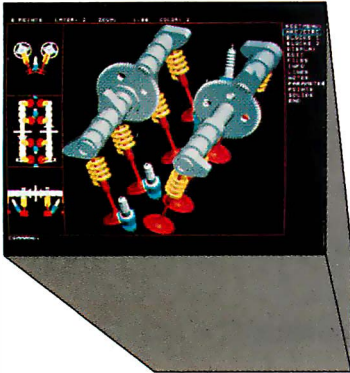

VERY EASY TO USE

Just because DesignCAD 3-D is powerful doesn't mean it is difficult to use. Single keystroke commands and side-bar menus which give short directions on how to proceed make DesignCAD 3-D a snap to use! While not required, DesignCAD 3-D supports all popular digitizers and mice.

Many of the older, more cumbersome CAD systems require weeks of training before a user can be productive. DesignCAD 3-D users find they can be producing useful drawings in a matter of minutes! In a recent CAD contest only one contestant was able to match our drawing time. The package sold for \$3000.00. The other CAD packages took up to twice as long to perform the same drawing and cost up to \$5000.00!

Still don't believe us? The goblet pictured below required only 16 keystrokes and 3 commands to create! The top, front, side, and isometric views were created simultaneously... in less than one minute!

VERY LOW PRICED

The first question asked by many people is, "Why is DesignCAD 3-D priced so low?" The answer? After developing DesignCAD 3-D version 2.0, we were unable to decide how the product should be priced. We consulted experts. We used the finest spreadsheets on the market. We took employee polls. Finally, in the great American Tradition, we said, "Aw... What the Heck! Let's see the other guys beat this price!" DesignCAD 3-D version 2.0 sells for \$399.

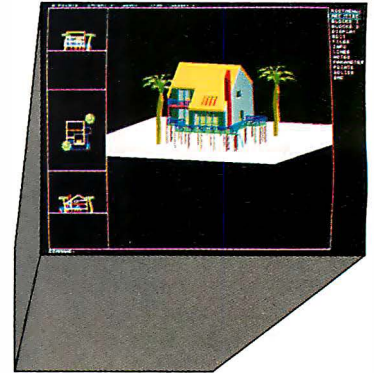

DesignCAD 3-D only \$399!

WHY BUY THIS ONE?

There is a very important reason to buy DesignCAD 3-D. PERFORMANCE. No other CAD system can match our price/performance ratio. Many people make the serious mistake of thinking that it is necessary to spend thousands of dollars to obtain "a good 3-D CAD system." This is not true! We talk to people everyday that are sadly disappointed with their "expensive" CAD systems. Don't be one of them! Call us and we will send you a complete set of literature and a free slide show demo disk. Once you compare DesignCAD 3-D version 2.0 with other CAD systems we know you will choose DesignCAD 3-D.

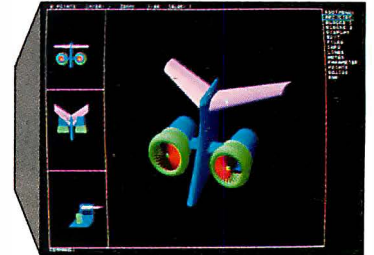
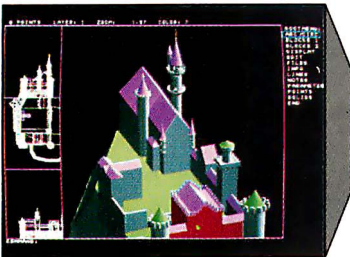

DON'T TAKE OUR WORD FOR IT

Here is what other people have to say about DesignCAD 3-D:

"After you've worked with DesignCAD, the single keystroke commands are simple to remember and it becomes easy to "flick one key" to execute a command. An extremely ergonomically designed program."

HENRY LEVET, Levett & Daigle Architects - New Orleans, LA
Designed a 65,000 sq. ft. nursing home using DesignCAD

"Recently I worked with a firm that builds decks. They purchased your product on my recommendation. I sat down with them and in two hours they were very proficient in DesignCAD. Now they are more effective; and we can communicate... it's wonderful to be able to do a block repeat 42 times and there are 42 2x4's to make the deck!"

J. TURNER, Architect, TAO Ltd. - The Woodlands, Texas

"Allows scientists and engineers to expend minimum time learning and using CAD software so that their time can be expended on the project at hand. It also allows scientists and engineers to quickly present to management all views of a subject. (3-D)."

DR. STEVENS, NASA Space Scientist/Engineer

HOW DO I GET ONE?

DesignCAD 3-D version 2.0 is available from most retail computer stores, or you may order directly from us. DesignCAD 3-D is available in a number of foreign languages from distributors throughout the world. All you need to run DesignCAD 3-D is an IBM PC Compatible and 640K RAM. DesignCAD 3-D supports most graphics cards, printers, plotters and digitizers. Free information and a demo diskette are available by contacting us at:



American
Small Business Computers, Inc.

327 South Mill Street
Pryor, OK 74361
918/825-4844
FAX: 01-918-825-6359
TELEX: 9102400302

siders this the best all-around microcomputer controller in the world. The controller card has a 68000 chip on-board; in fact, this controller is smarter than the 128K-byte Macintosh was. It comes with half a megabyte of disk cache memory; you can also get an optional 4 megabytes on a second board. The two boards are to be connected with a ribbon cable, and that was our first problem.

Big Cheetah wants his disk controller in the first slot (in a tower, that's the top slot). The next two slots are for 32-bit memory and are labeled "High Word" and "Low Word." Thus, the PM3011 needs to go in slot 1, and its additional memory has to go in slot 4. The problem was that the cable Larry brought was just long enough to bridge one of the memory boards. There was no way it was going to bridge two; we had to leave out the extra memory.

It doesn't seem to matter: the PM3011 can use all that memory when it's servicing a number of busy users, but there's not much way that I'll need it, even if I keep a dozen DESQview windows open at once. The Coretest utility can't even measure the seek times on this controller and the Priam drive: something less than half a millisecond! I have the memory board here, and I suppose one day I'll install it; but I doubt that I'll notice the difference.

It was now time to reformat the Priam 330-megabyte hard disk drive. In preparation, I had copied everything off onto the Maximum Storage WORM (write once, read many times) drive. That took almost an hour, since I decided to copy all the files onto a new WORM cartridge. Next time, I'll copy only those with dates later than the last backup, but we were due for a new complete backup.

The DPT format program asks you for your disk's defect list. We laboriously read that off the table glued on top of the Priam drive; something we'll never have to do again, since the DPT software will write off the list to a floppy disk. I've since learned, though, that this is needless work; the DPT format program automatically finds all the bad sectors anyway.

Before formatting, we put Big Cheetah back together again. I thought that was an act of defiance sure to be punished by the gods; generally, I do all my tests before putting the case back on. Larry Aldridge disagreed. "I don't see how it can be good for a disk to format it while it's on its side," he pointed out. "There's sure to be gravity drag, and it just doesn't seem reasonable." After I thought that over, I had to agree. I do

know a lot of people who take an ordinary machine and stand it on edge (and, thus, the hard disk drive on its side). I don't know if that causes any problems, but perhaps it's best not to take chances.

Once Big Cheetah was back together, we tried to fire him up. It didn't work. The controller couldn't find the hard disk. The PM3011 wants you to tell it that your hard disk is a Type One, even though it's not likely to be. The controller then looks at the disk to determine the true number of heads and tracks and sectors. Unfortunately, it didn't at all like what it was finding out about my Priam drive.

It turns out that some early Priam drives were formatted to only 310 megabytes rather than 330. I'm not sure why; I think Larry explained it, but I've forgotten. The important point is that the controller couldn't recognize this format, and it kept making plaintive noises while it hunted.

The solution was to remove the data cable while the machine booted up from a floppy disk. Then we reconnected the cable and started the format process. That takes a bit more than 2 hours, so we

went to lunch. When we came back, the formatting was done, and it was time to partition the disk.

There are many partitioning programs. If you don't want any single partition to be larger than 32 megabytes, the DOS FDISK utility will do the job. If you want larger partitions, there are a number of choices. One is DOS 4.0x, which also has other advantages; but from everything I have heard, it will be another few weeks before that's stable enough to use reliably. I'm a believer in the old adage of "Be not the first by whom the new is tried, nor yet the last to cast the old aside," and I think I'll stay with DOS 3.3 for a while yet.

If you rule out DOS 4.0x, there are several commercial programs to make large partitions. The one that I normally use is SpeedStor. Larry Aldridge likes Disk Manager from Ontrack Computer Systems. Both Cheetah and DPT recommend Disk Manager. In our case, it didn't matter. We used Disk Manager to set up my big Priam drive with two 32-megabyte drives and one humongous 260-megabyte drive, but when we booted

continued

People are talking about us.

When professional FORTRAN programmers develop or port large programs they use Lahey's F77L-EM/32 and F77L-EM/16, *PC Magazine's 1988 Technical Excellence Award Winners*. F77L-EM/32 is a fast 32-bit protected-mode compiler that accesses up to 4 gigabytes of memory on 80386s. F77L-EM/16 gives 80286 users the power to create 15 megabyte programs. These protected-mode FORTRANs include the features that have made them, and our F77L and Lahey Personal FORTRAN, market leaders: full ANSI 77 Standard, VAX and IBM VS extensions, fast compilation, comprehensive diagnostics, and a powerful debugger.



When people talk about FORTRAN
the name mentioned most often is

Lahey
Computer Systems Inc.

Contact us to discuss our products and your needs. (800) 548-4778
Lahey Computer Systems, Inc. P.O. Box 6091, Incline Village, NV 89450
Tel: (702) 831-2500 FAX: (702) 831-8123 Tlx: 9102401256

BEST



Complete 386 SYSTEM

- 80386-20 MHz CPU
- Support 80287, 80387 & WEITEK processor
- Six 16 Bit, Two 8 Bit BUS
- 1 MB RAM (Expandable 2,4,8 MB on board), 32 Bit
- RAM Architecture (Interleaved Page Mode)
- AMI Bios
- Realtime Clock/Calendar
- 1.2 MB Floppy Drive
- Fast 1 to 1 Interleaved Hard Disk Controller
- VGA Adapter & VGA Monitor
- 80 MB Hard Drive (287ms)
- 101 Enhanced Keyboard
- Vertical Case
- MS-DOS 3.3 GW Basic
- 1 Year Warranty
- Support: NOVELL/3COM/PC NET/LanLink/OS/2

\$2990

NEW MINI PORTABLE BEST-286 LCD

- 10 MHz 0 WAIT (12MHz Option)
- 512 K RAM
- 1.2 M. Floppy Drive
- 30 MB Hard Disk (Seagate 138 28ms)
- 200 W DC Fan Power Supply
- Serial & Parallel
- Non-Glare LCD Screen
- Super Twist
- Built-In Back Light
- 640 x 200 Dots
- Weight 22 lbs
- Padded Soft Carry Bag
- Dimension 16" x 8" x 9"

\$1600



286 BABY MOTHER BOARD

- 10 MHz \$265
- 12 MHz \$295
- Mono Monitor \$79
- Fujitsu 101 Enhance Keyboard \$45
- EGA PLUS 640 x 480 (Paradise Compatible) \$139

PORTABLE CASE

- 9" Dual Amber Monitor
- 200 W Power Supply \$359

LCD CASE

- 640 x 200 Dots \$549



VTI-33 SYSTEM

- 8088-2 10 MHz
- 640 K RAM**
- 2 360K Floppy Drive
- Serial, Parallel Port
- Clock, Calendar
- AT Style Keyboard
- Build in Mono/Color Graphic
- MONO MONITOR**
- MS-DOS 3.3, GW Basic

\$749

COLOR SYSTEM \$919

BEST-286 PORTABLE

- 10 MHz (12 MHz Optional)
- 512 K RAM
- One 1.2 MB Floppy Drive
- 7 Expansion Slots
- 200 W DC Fan Power Supply
- 9" Dual Amber Screen
- Mono or Color Graphic Card
- 2 Serial & 1 Parallel Port
- 84 Key Soft Tough Key Board

\$1115

BEST-88 PORTABLE \$845



VTI-55 SYSTEM

- 80286 8/12 MHz
- Award bios
- 640K-120ns
- 1.2 MB Floppy Drive
- 40 MB** Hard Disk Seagate ST-251 with NCL
- 2 Serial 1 Parallel
- Clock Calendar
- 101 Enhance Keyboard
- ATI EGA Wonder Card
- EGA MONITOR**
- MS-DOS 3.3, GW Basic

\$1799

MONO SYSTEM \$1499

One Year Warranty

CALL FOR QUANTITY PRICE

BEST COMPUTER INC.
5017 Telegraph Road
Los Angeles, CA 90022

MON - SAT 9:00 - 6:00 PACIFIC TIME
PRICE & SPEC. ARE SUBJECT TO CHANGE WITHOUT NOTICE

Circle 42 on Reader Service Card
(DEALERS: 43)

Tel: (213) 265-0900
Tech: (213) 265-0300
Fax: (213) 265-4234
Toll: **(800)634-7920**
Outside Cal.



Credit Card Purchase Subject to Service Charge.

up the system, it wouldn't work. We could access the smaller C and D drives, but things got flaky when we tried to read and write to the enormous E drive. Worse, when I used XCOPY to bring some files from the WORM drive (now F), it all seemed to work, but only about half the files actually got copied. Something clearly was wrong.

The next step was to repartition the disk. We needed to get rid of that enormous logical drive and divide things up into a bunch of 32-megabyte drives.

That didn't work, either. XCOPY still wasn't reliable. Neither were some other utilities. Something was really wrong.

It was also well after midnight. Between one thing and another, we'd been at this for over 10 hours, and while Larry Aldridge was willing to stay on, I sent him on his way; but first, I made sure that I kept all the parts that had been replaced on Big Cheetah.

Troubleshooting

Back when I was in the aerospace business, I sometimes had to run laboratories. In those days, we were creating new technology, particularly in medical electronics, and invariably, just before a big test something would go wrong. I got a reputation as an electronic genius because we'd send for the engineers, and while they were trying to understand what had gone wrong, I'd very likely get the equipment going.

My reputation was truly undeserved; most of that stuff was far beyond my technical competence, and if I'd tried to reason my way, I'd have been as lost as the engineers were. Instead, while they were thinking, I puttered about. "Relentless application of logic," I'd mutter, while trying to put things back the way they were the last time it all worked; then I'd add a component at a time, testing as I went along.

It seemed to me that the same technique was called for here. The problem with Big Cheetah was that we'd made several changes at the same time; the thing to do was put the machine back the way it was and start over.

First, I put the old motherboard back in. Next thing would be to put the original Priam controller in. On the other hand, reformatting would take hours. It was already very late, well after midnight, and I had heard a lot of good things about the DPT controller. It couldn't hurt to give it one more try. . . .

My first attempt was an utter failure. It turns out that the red stripe on the drive cable goes to the left on floppy disk drive A, but to the right on B (which is a 3½-

inch drive). It's also not clear which way it goes on the controller. Once I got that fixed, I held my breath and booted up.

It worked fine. Disk access was faster than anything I'd ever seen before, and after half an hour I was pretty well convinced the system was reliable. Later, I found out that the problem was an intermittently faulty chip on the new motherboard.

For the moment, though, I had a different problem. Since I now had the same disk partitions I'd had the day before, except for the last one (the DPT controller formats about 10 more megabytes on the Priam drive than it had previously), it seemed logical simply to copy all the files from the WORM right back to where they'd been. That would be simple enough, since I'd created directories C1, D1, E1, and so forth on the Maximum Storage WORM cartridge and used XCOPY to move everything, subdirectories and all, for each logical drive. To restore it then, all I had to do was type:

```
XCOPY N:\C1\*.* C:\v\s/e
```

and repeat that for drives D through J

(there not being anything worth keeping on drives K through M).

All went well until I got to drive F; then I got DOS error messages. Strange DOS error messages.

It was now very late, but I was determined to have the machine running before I went to bed.

New Norton Disk Doctor

The first thing I tried was Norton Disk Doctor. There's a story to that. You may recall that when I used NDD the last time I had problems with my hard disk, it managed to vanish my C drive. I wrote that up and sent a copy of the manuscript to Peter Norton.

The next morning, I'm told, Norton instituted a crash program to fix the problem. A week later, a messenger delivered an updated NDD with a note promising that this one would work properly. I tried it out on a couple of other machines without difficulty, but of course that didn't tell me much. Here was a chance to test it on a disk with real problems.

It looked at drive F and asked, "Do
continued

People are talking about us.

"Lahey F77L is definitely for the programmer's market, with features for the casual and professional user...*EDITOR'S CHOICE*" *PC Magazine*

"It is a fantastic product." *PC Australia*

"This is a very good implementation of FORTRAN, better than the one I use on my minicomputer system." *IEEE Software*

"It should be the last FORTRAN compiler you will need to buy..." *Your Computer*

"Lahey F77L was by far the easiest compiler to use..." *Programmer's Journal*

"Compilation speed is Lahey FORTRAN's most remarkable feature; it is unbelievably fast...Realistically, Lahey FORTRAN is the most efficient and productive FORTRAN development tool for the DOS environment..." *Byte*

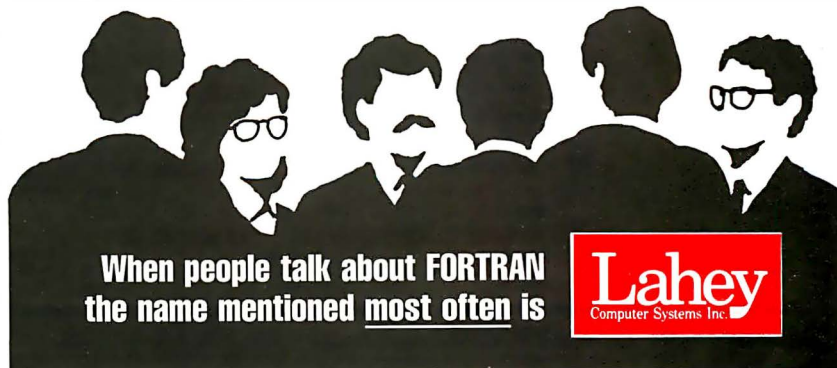

When people talk about FORTRAN
the name mentioned most often is

Lahey
Computer Systems Inc.

Contact us to discuss our products and your needs. (800) 548-4778
Lahey Computer Systems, Inc. P.O. Box 6091, Incline Village, NV 89450
Tel: (702) 831-2500 FAX: (702) 831-8123 Tlx: 9102401256

telemart 1-800-634-9270

ORDER LINE

Doing Business Since 1980 A Division of CW Marketing, Inc.



**The Acknowledged Leader
in the Computer Mail Order Industry**
Call About the Availability of Other Products Not Listed.



FREE
AIR EXPRESS SHIPPING
You Pay The Ground Shipping
We Pay The Air Difference



PC/XT SYSTEM

10MHz, 640K Memory, 150 Watt Power Supply, AT Style Keyboard,
1-360K Drive, AT-Style Case, Monographics Card with Parallel Printer
Port, Clock Card with Serial Port, Mono Monitor with Swivel Tilt Base

\$709

System w/2-360K Drives . . . \$787

System w/1-360K DR 1-20 Meg . . . \$994
System w/1-360K DR 1-30 Meg . . . \$1021

IBM SOFTWARE

WORD PROCESSORS

| | |
|-----------------------------------|------|
| Easy Extra | \$53 |
| Grandview | 175 |
| Multimate Advantage II | 275 |
| PFS: Professional Write | 102 |
| Volkswriter 4 | 89 |
| Volkswriter Deluxe Plus | 57 |
| Word (Microsoft) | 179 |
| Word Perfect 4.2 | 205 |
| Word Perfect 5.0 | 205 |
| Word Perfect Executive | 117 |
| Word Perfect Library | 58 |
| Wordstar Pro Pack | 233 |
| Wordstar 2000 Plus 3.0 | 239 |

DISKETTES

| | |
|-------------------------------------|------|
| Maxell | Call |
| Sony 5 1/4 Qty. 100 OS/DD | \$65 |
| Sony 3 1/2 Qty. 100DD | 129 |
| Sony 3 1/2 HO Qty. 100 | 319 |

DESKTOP PUBLISHING

| | |
|--------------------------------|-------|
| Pagemaker 3.0 | \$459 |
| PFS: First Publisher | 65 |
| Ventura Publishing | 445 |

LANGUAGES

| | |
|-------------------------------------|-------|
| Basic Compiler (MS) | \$176 |
| C Compiler (MS) | 266 |
| Cobol Compiler (MS) | 531 |
| Fortran Compiler (MS) 4.1 | 266 |
| Macro Assembler (MS) | 89 |
| Pascal Compiler (MS) | 179 |
| Quick Basic | 59 |
| Quick C | 59 |
| Turbo Basic | 62 |
| Turbo C | 88 |
| Turbo Pascal 5.0 | 88 |
| Turbo Pascal Dev. Library | 228 |

GRAPHICS

| | |
|--------------------------------------|-------|
| Designer | \$399 |
| Draw Plus | 229 |
| Generic CAD w/Dot Plot 3.0 | 72 |
| Harvard Graphics 2.1 | 255 |
| In-A-Vision | 262 |
| Microsoft Chart 3.0 | 234 |
| Newsroom | 15 |
| PC Paintbrush Plus | 69 |
| Printmaster Plus | 28 |
| PrintShop | 32 |
| Publishers Paintbrush | 132 |
| Turbo Graphix Tool Box | 62 |
| VP Graphix | 56 |

UTILITIES

| | |
|------------------------------------|------|
| Brooklyn Bridge | \$69 |
| Copy II PC | 18 |
| Cruise Control | 28 |
| Disk Optimizer 4.0 | 37 |
| Disk Technician Advanced | 101 |
| Disk Technician Plus | 67 |
| Fastback Plus | 98 |
| Mace Utilities | 47 |
| Microsoft Windows 286 | 59 |
| Microsoft Windows 386 | 115 |
| Norton Utilities 4.5 | 47 |
| Sidekick Plus | 125 |
| Sideways | 37 |
| SO2 Plus | 53 |
| Take Two Mgr. | 59 |
| XTree Professional | 61 |

DATA BASE MANAGEMENT

| | |
|--------------------------------------|-------|
| Clipper | \$405 |
| DB-XL Diamond | 107 |
| Nutshell Plus | 185 |
| Paradox 2.0 | 403 |
| PFS: Professional File 2.0 | 152 |
| Q & A | 199 |
| R:Base For DOS | 449 |

MONEY MANAGEMENT

| | |
|--|------|
| Dollars & Sense w/Forecast | \$91 |
| Tobias Manag. Your Money 5.0 | 114 |

COMMUNICATIONS

| | |
|---------------------------------------|-------|
| Carbon Copy Plus | \$106 |
| CompuServe Subscription Kit | 19 |
| Crosstalk XVI | 87 |
| Crosstalk Mark IV | 109 |
| Mirror III | 49 |
| Remote 2 | 87 |
| Smartcom II | 79 |
| Smartcom III | 136 |

INTEGRATIVE SOFTWARE

| | |
|---------------------------------|-------|
| Ability Plus | \$137 |
| Enable 2.0 | 369 |
| Framework III | 409 |
| MS Works | 88 |
| PFS: 1st Choice | 82 |
| Smart Software System | 454 |
| Symphony | 409 |

MICE

| | |
|---|------|
| PC Mouse w/paint (Buss or Serial) | \$81 |
| PC Mouse w/Autosketch Buss | 97 |
| w/Autosketch Serial | 97 |
| Microsoft Buss Mouse 1.0 | 95 |
| Microsoft Serial Mouse 1.0 | 95 |
| MS Buss Mouse w/CAOD | 109 |
| MS Buss Mouse w/Windows | 125 |
| MS Serial Mouse w/CADD | 109 |
| MS Serial Mouse w/Windows | 125 |

SPREADSHEET

| | |
|-----------------------------------|------|
| Cambridge Analyst | \$80 |
| Lotus 1-2-3 Ver. 2.01 | 285 |
| Lotus Manuscript | 299 |
| MS Excel | 215 |
| MS Excel/Mach 20 Bundle | 620 |
| Multiplan 4.0 Microsoft | 116 |
| Quattro | 146 |
| Supercalc 5.0 | 305 |
| VP Planner | 47 |
| VP Planner Plus | 112 |

IBM HARDWARE

PRINTERS

| | |
|----------------------------------|-------|
| ALPS | |
| Allegro | \$345 |
| All Other Models | Call |
| AST Turbo Laser | 2865 |
| Brother | |
| M1109 | 139 |
| LAZER | Call |
| Other Models | Call |
| Citizen Printers | |
| 120D | 145 |
| 180D | 165 |
| All Other Models | Call |
| Diconix 150 | 305 |
| Epson | |
| FX850 | 355 |
| LQ850 | 555 |
| LQ500 | 295 |
| LX800 | 175 |
| All Other Models | Call |
| Hewlett-Packard | |
| Laser Jet Series II | 1785 |
| Paint Jet | 1085 |
| Desk Jet | 725 |
| All Other Models | Call |
| NEC | |
| P2200 | 339 |
| P5200 | 505 |
| P5300 | 679 |
| All Other Models | Call |
| Okidata | |
| 320 | 319 |
| 321 | 449 |
| 390 | 449 |
| New Lasers | Call |
| All Other Models | Call |

PANASONIC

| | |
|----------------------------|------|
| 1124 | 329 |
| 1180 | 185 |
| 1191 | 249 |
| All Other Models | Call |
| Star Micronics | |
| NX 1000 | 169 |
| NX 1000 Rainbow | 225 |
| NX 2400 | 305 |
| All Other Models | Call |
| Toshiba | |
| 311 | 385 |
| Pagelazer | 2535 |

MODEMS

| | |
|----------------------------|------|
| Anchor | |
| 1200B w/Software | \$89 |
| 2400EXT | 135 |
| 2400B w/Software | 119 |
| Haves | |
| All Models | Call |
| Prometheus | |
| 1200B w/Software | 70 |
| 2400B w/Software | 125 |
| Other Models | Call |
| US Robotics | |
| 9600 | 589 |
| 2400 | 125 |
| All Other Models | Call |

NETWORKING

| | |
|------------------|------|
| Novell | Call |
|------------------|------|

HAND SCANNERS

| | |
|---------------------|-------|
| Complete | |
| 400 | \$139 |
| Half Page | 175 |

DISK DRIVES

| | |
|---------------------------------|-------|
| Bernoulli Box | |
| 10 Meg | \$889 |
| 20 Meg | 1250 |
| Betalnt 20 Meg | 765 |
| Headcards | |
| Plus 20 MG Hardcard | 509 |
| Plus 40 MG Hardcard | 645 |
| Passport | Call |
| Magnum Tape Back Up | |
| 4 M MG | 340 |
| Seagate | |
| 20 MG w/WD Controller | 275 |
| 251-1 40 Meg AT | 435 |
| 40 MG w/Controller | 439 |
| All Other Models | Call |
| Teac | |
| 1.2MGAT | 85 |
| Floppy 360K | 70 |
| Toshiba | |
| 3.5 Dr 720K | 79 |
| 3.5 Dr 1.4 MG | 99 |

KEYBOARDS

| | |
|-------------------|------|
| Keytronics | |
| KB101 | \$85 |
| KB5151 | 119 |

TERMINALS

| | |
|--------------|-------|
| Wyse | |
| 30 | \$295 |
| 50 | 370 |

FAX MACHINES

| | |
|-----------------|-------|
| Brother | |
| 150 | \$919 |
| Sharp | Call |

BOARDS

| | |
|--------------------------------|-------|
| AST | |
| Six Pack Plus w/384K | \$269 |
| VGA + | 329 |
| All Other Models | Call |
| ATI | |
| EGA Wonder | 225 |
| VGA Wonder | 305 |
| Hercules | |
| Graphics Card Plus | 175 |
| All Other Models | Call |
| Intel | |
| Inboard 386 PC | 720 |
| Co-processors | Call |
| Aboveboard | Call |
| Orchid | |
| Designer 800 | 235 |
| Pro Designer | 295 |
| Pro Designer + | 385 |
| Tiny Turbo 286 | 260 |
| Paradise | |
| Autoswitch 350 | 155 |
| Autoswitch 480 | 170 |
| All Other Models | Call |
| Video-7 | |
| Fastwrite VGA | 345 |
| VGA | 265 |
| Vega deluxe | 205 |
| Zenith | |
| 449 | 239 |

FAX BOARDS

| | |
|-----------------|-------|
| Complete | |
| 4800 | \$225 |
| 9600 | 389 |

COMPUTERS

| | |
|------------------------------|-------|
| Amstrad | |
| Dual Drive | \$775 |
| Single Drive | 775 |
| AST | |
| Model 80 | 1560 |
| Other Models | Call |
| Toshiba | |
| T-1000 | 789 |
| Graphics Card Plus | 1599 |
| T-1600 | 3375 |
| T-3200 | 3665 |
| T-5100 | 4800 |
| Zenith | |
| Supersport/2 | 1629 |

MONITORS

| | |
|----------------------------|------|
| Amdek Monitors | |
| 210A | \$80 |
| 410 | 135 |
| Mitsubishi | |
| Diamond Scan 14" | 499 |
| NEC | |
| Multisync II | 589 |
| Multisync Plus | 899 |
| Multisync 3D | Call |
| Other Models | Call |
| Pricelton | |
| Ultrasync 12" | 499 |
| Ultrasync 16" | 839 |
| Other Models | Call |
| Sony | |
| Multiscan (1303) | 545 |
| Zenith 1490 | 599 |



No Charge for VISA and Mastercard.
We Do Not Charge Your Card Until Your Order is Shipped.
All products including D.C.A.s, carry only manufacturer's warranties. We do not honor guarantees, rebates, trial period privileges or promotional programs offered by manufacturers.
*Noretur used on or misordered product.
*You Pay The Ground Shipping 1-10# \$6.00, 11-20# \$10.00 (Except Alaska & Hawaii), We Pay The Air Difference.

*Free Air Applies ONLY to Orders Over \$100.
*No APO, FPO, or International orders please.
*Call Before Submitting P.O.'s. Ask for National Accounts.
*Personal and Company Checks Will Delay Shipping 3 Weeks.
*Prices, Terms & Availability Subject to Change Without Notice.
*Add 5% for C.O.D. Orders.
*We Do Not Guarantee Machine Compatibility.
*Mailing Address: TELEMART, 8804 N. 23rd Ave., Phoenix, AZ 85021.

*To Place an Order: 1-800-528-1054.
*To Follow Up On An Order: (602) 944-1037.
*Order Line Hours:
Mon.-Fri. 7:00am-6:00pm
Saturday 9:00 a.m.-1:00 p.m.
*Order Processing: (602) 944-1037
10:00a.m.-3:00p.m. Mon.-Fri.



you get bizarre results when you attempt to access this drive?"

"I sure do," I muttered. When NDD offered to fix things, I told it to have at it.

NDD suggested that there were fragmented files, cross-connected files, and other problems with the FAT (file allocation table) on drive F, and it suggested that I first run CHKDSK/F to gather up all the lost chains.

That sounded good to me, but it didn't work. The disk held about 20 megabytes of garbage. CHKDSK trundled for a while and reported: "Insufficient room in root directory — Erase files from root and repeat CHKDSK."

Sheer Madness

There were two problems with this. First, I couldn't read the root directory of drive F, and ERASE F: \ *.* produced no result whatever.

Second, I must have taken leave of my senses. It's one more reason why you shouldn't do this sort of thing at 4:00 a.m. after a long day of frustration. Somehow I got the notion that instead of the root directory of logical drive F, the problem was that I had no space on C: \, the primary root, and I had to erase some files *there*. Of course, in the cold light of day that sounds as absurd to me as it does to you, but it seemed like a good idea at the time. I invoked Norton Commander and selected all the files in C: \, figuring to erase them, then bring back the few I needed. Norton Commander warns you when you're about to erase a READ ONLY file, but I didn't pay any attention. Do it, I said.

I managed to delete not only COMMAND.COM, but IBMBIO.COM before I realized what I was doing and frantically hit Control-Break.

Too late. I couldn't exit from Norton Commander, and when I reset the machine, it refused to boot.

The first rule is, don't panic. It was clear I'd have to reboot with a floppy disk and transfer the files back to the C drive. That would have been simple enough, but I was still muddleheaded: I copied COMMAND.COM and IBMBIO.COM from drive A to drive C. The result was that I could access the C drive, but I couldn't boot from it; and when I tried to use SYS.COM to transfer the system over to the C drive, I got "No room for system on target disk."

I expect the proper way to recover from that would be to use Norton Commander to erase the first several files in the C: \ directory—probably the COMMAND.COM I copied previously—since IBMBIO.COM has to be the first

file in the FAT; but by then I was plain disgusted and did FORMAT C: /S.

That was partly an experiment to see if you really can format one logical drive without disturbing the others. I've always wondered, and what with everything backed up on the Maximum Storage WORM drive, there would never be a better time to try. It worked fine. All the files on drives D and E were undisturbed. Drive F was still giving bizarre results.

All right, thought I, if FORMAT works on the C drive, it ought to work on the F drive, so let's try that.

There's only one problem. FORMAT demands the volume name of the drive, and if you don't know it, the program refuses to proceed. I have a utility called VOLNAMES (and there's DOS's VOL); using that showed that while none of my other logical drives had volume names, drive F had a garbage label containing control and graphics characters. There was no way I could type that in.

Examining the index references in the DOS documents and Chris DeVoney's book *Using PC-DOS* gave no hint of a way to remove a volume name except by

formatting the disk; but to format the disk, I'd need the label.

By this time, I was frothing at the mouth. There had to be some way of doing this without reformatting the whole disk. If FORMAT wouldn't work, would FDISK? I tried that, and it indeed offered to remove a partition. Fine, thought I. Remove the F partition. It did; then, of course, it closed things up, so there was an F again, this time without a volume label; on the other hand, I was short some 32 megabytes of drive space. Worse, NDD informed me that drive G was acting in a bizarre manner.

Fortunately drive G had no volume name, so I could format it easily enough. The DPT controller does that quite rapidly, so I wasn't losing much time; and after that was done, there were no problems other than the missing disk space. For a moment, I thought of ignoring the problem. After all, I had nearly 300 megabytes and wasn't using half of it. I could live without that space. . . .

Sure I could, but there was no chance I would. I got out FDISK again and told it to create one more logical drive using all

continued

People are talking about us.

Not everybody needs a Lahey large memory-model compiler...some need Lahey Personal FORTRAN 77, the price/performance leader.

Complete ANSI 77 Standard
Fast Compilation
Calls Quick & Turbo C Routines
Math Coprocessor Emulation
Complete 400 Page Manual

Powerful Debugger
Mainframe Features
Helpful Error Messages
Linker and Library Manager
Expert Technical Support

COMPLETE
PACKAGE ONLY
\$95
Ask about our
Toolkit Special



When people talk about FORTRAN
the name mentioned most often is

Lahey
Computer Systems Inc.

Contact us to discuss our products and your needs. (800) 548-4778
Lahey Computer Systems, Inc. P.O. Box 6091, Incline Village, NV 89450
Tel: (702) 831-2500 FAX: (702) 831-8123 Tlx: 9102401256

the space it could find. That took no time at all, and lo!, I was finished.

There's one anomaly and one footnote to the adventure. The anomaly is this: I have 11 logical disk drives. C through K are identical in size at 33,298,932 bytes. Drive L is quite small, 1,871,872 bytes. So far that's what you'd expect; but the last drive, M, has 32,915,976 bytes. That's a consequence of my unpartitioning space, then reclaiming it again.

The footnote is that I didn't need to do

that. DOS 3.x and higher has the LABEL command, which will let you change or delete volume labels. Unfortunately, it's not properly indexed, so you either have to know it's there or read the DOS manual to find out about it.

The bottom line to all this, though, is that the DPT controller has worked splendidly. It's superfast and superquiet. The Coretest Performance Index is 48; by contrast, a generic XT with a fast hard disk drive might get as high as 3.8, while

the Priam drive under its ESDI controller was about 22. The DPT controller works with DESQview, Windows/386, and everything else I've tried on it. Moreover, as long as I'm using normal DOS-size partitions, there's no need for ESDI.SYS, thus saving several kilobytes of primary memory. I don't really have any need for a controller this good, but if you're looking for something to control a big multiuser system, or a file server, or if you just want high speed and high reliability, you'll love the PM3011. Highly recommended.

System Sleuth

If you have ever been curious about your computer, you'll want this program. System Sleuth will tell you all kinds of things: what your CPU processor is, how many heads and tracks on your hard disk, what disk drives you have, how much RAM, who copyrighted your BIOS, what your display adapter is, and in general, more than you ever thought you'd want to know about your system.

It gives you an I/O map and memory maps. This can be especially useful if you're trying to make use of the memory between 640K bytes and 1 megabyte. DESQview's QEMM.SYS and LOADHI.SYS can use that memory to store device drivers (like the mouse or WORM drives) up beyond main memory. However, 16-bit VGA video also uses some of that space and is loaded before LOADHI.SYS can get at it. The result can be fairly mysterious crashes if you don't know what's happening. The thing to do is boot up without QEMM.SYS, then use System Sleuth to look at those memory blocks and see what's in use.

This is one of those programs that I didn't know I needed until I got it; now, what with all the hardware I try out around here, I use it all the time, and I can't think how I got along without it. There's one odd omission: it doesn't tell you whether or not you have a math chip. Oh, well.

System Sleuth is simple to use, and the main reason to refer to the documents is to find out just why you wanted to know something the program is telling you.

Highly recommended.

Duet

This is another one of those programs you don't know you need until you try it. Duet is a memory-resident program that sets your laser printer: if you have a font cartridge, Duet will tell the printer to use it. It will also cause the LaserJet Plus to print sideways. Finally, it will build a

continued

New! Turbo Pascal Tools for Powerful Multi-User Databases

Write powerful multi-user databases faster and easier using the language you love - Turbo Pascal - and B-Tree Filer 5.0. Easily upgrade your present applications that use Borland's Database Toolbox.

The Performance and Connections You Need

You'll have the fastest, safest, most flexible databases when you use B-Tree Filer 5.0 - no rigid structure, no TSR hassles, no running out of files. And they're compatible with Novell, 3Com, MS-NET, and others.

The Complete B-tree Tool Kit

In over 100 Turbo 5.0 procedures you get:

- Fixed and variable length records • Two billion records per database • 100 keys per index file
- Flexible record locking • B-tree indexing with advanced page balancing • Fail-safe mode with journaling • Units for sorting, browsing, reindexing, and reorganizing • Same source runs on any network • Complete source code. B-Tree Filer includes full documentation and technical support and you pay NO royalties.

B-Tree Filer 5.0 is only \$125. (single user)

Multi-user version with network support, only \$175.

Call toll-free for credit card orders.

1-800-538-8157 ext 830 (1-800-672-3470 ext 830 in CA)

Complete capabilities brochure available, call 408-438-8608 (9 to 5 PST) or write for more information. Also from TurboPower:

- Turbo Analyst 5.0, tune and document your programs, only \$99.
- Turbo Professional 5.0, the best general purpose library, \$125.

Satisfaction guaranteed or your money back within 30 days. Turbo Pascal 4.0 or 5.0 is required. Shipping and taxes prepaid in U.S. and Canada. Elsewhere add \$15 per unit.



TurboPower Software
P.O. Box 66747
Scotts Valley, CA 95066-0747

It Will Forever Change The Way You View Your Existing Software And Data!

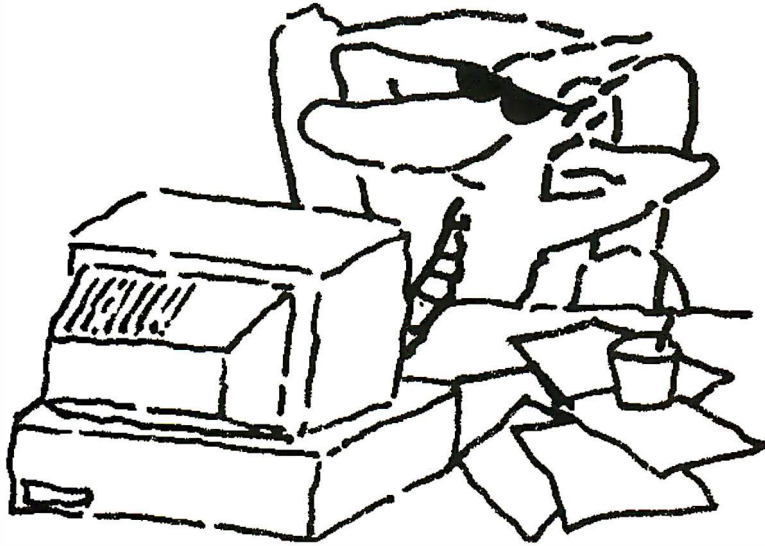

Here's What The Critics Are Saying About ViewLink...

"The most significant new product of the late DOS era ... a visionary solution - a beacon of good sense and productivity."

Jeff Angus, INFOWORLD
-Feb. 6, '89

"In a computer market that's overflowing with 'me-too' products, ViewLink is potentially one of the most important products to appear in the past year."

BYTEWEEK -Jan. 30, '89

"ViewLink provides a welcome new way of managing applications."

Jimmy Guterman, PC WEEK -Jan. 30, '89

"What a great idea... ViewLink is an idea that's long overdue for any DOS computer."

Don Crabb, CHICAGO-SUN TIMES-Feb. 19, '89

"ViewLink performs the type of service users should expect of their operating system..."

Jeffrey Tarter, SOFT•LETTER

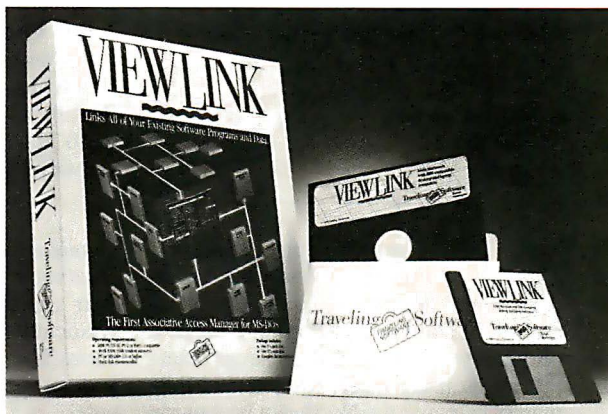

Now that you've heard what the critics are saying about ViewLink ... imagine how much more efficiently you could work if all of your files were organized according to the way you use them. And not limited by their DOS directory or subdirectory structures.

Think of how much quicker you could get things done if you could load both the file you want to work with and its program at the same time—with a single keystroke.

Visualize how much more effective you could be if you could search an entire hard disk for related files—and group them together automatically.

That's the powerful idea behind ViewLink. A new easy-to-use method in connecting you with your software and data. It works with over 50 of today's most popular software applications. And it's only **\$149.95**.

From Traveling Software, the people who brought you LapLink, DeskLink and Battery Watch.

Available at your local computer store today.

For more information about ViewLink, call **1-800-343-8080** or in Washington state **206-483-8088**.

Traveling  Software

18702 North Creek Parkway • Bothell, WA 98011

Circle 270 on Reader Service Card

ITEMS DISCUSSED

| | | |
|--|--|--|
| CBC Tools\$175 Minnow Bear Computers P.O. Box 2233, Station A Champaign, IL 61825 (217) 344-1113 Inquiry 1030. | Mrs. Pournelle's Reading Program \$100 Roberta J. Pournelle 3960 Laurel Canyon Blvd., Suite 372 North Hollywood, CA 91604 Inquiry 1035. | QuickBASIC 4.5 \$99 Microsoft Corp. 16011 Northeast 36th Way P.O. Box 97017 Redmond, WA 98073 (800) 426-9400 (206) 882-8080 Inquiry 1040. |
| Cheetah 386/387 \$2195 Cheetah International, Inc. 107 Community Blvd., Suite 5 Longview, TX 75602 (800) 243-2824 Inquiry 1031. | Norton Utilities 4.5 Advanced ...\$150 Peter Norton Computing 2210 Wilshire Blvd., Suite 186 Santa Monica, CA 90403 (213) 319-2000 Inquiry 1036. | QuickPak \$79 QuickPak Professional\$149 Crescent Software 11 Grandview Ave. Stamford, CT 06905 (203) 846-2500 Inquiry 1041. |
| Disk Manager\$124.95 Ontrack Computer Systems, Inc. 6321 Bury Dr. Eden Prairie, MN 55344 (612) 937-1107 Inquiry 1032. | PM3011 \$1150 Distributed Processing Technology 132 Candace Dr. P.O. Box 1864 Maitland, FL 32751 (407) 830-5522 Inquiry 1037. | SpeedStor \$99 Storage Dimensions, Inc. 2145 Hamilton Ave. San Jose, CA 95125 (408) 879-0300 Inquiry 1042. |
| Duet \$89.95 Consumers Software, Inc. 736 Chestnut St. Santa Cruz, CA 95060 (408) 426-7311 Inquiry 1033. | Printer Optimizer\$349 Applied Creative Technology, Inc. 8333 Douglas Ave., Suite 700 Dallas, TX 75225 (214) 739-4200 Inquiry 1038. | System Sleuth\$149.95 DTG 23704-5 El Toro Rd., Suite 348 El Toro, CA 92630 (213) 987-2000 Inquiry 1043. |
| Jerry Pournelle's Accounting System \$99.95 Workman & Associates 1925 East Mountain St. Pasadena, CA 91104 (818) 791-7979 Inquiry 1034. | ProBas\$135 ProBas Toolkit \$99 Hammerly Computer Services, Inc. 9309 Jasmine Ct. Laurel, MD 20707 (800) 343-7484 (301) 953-2191 Inquiry 1039. | Turbo Cool 250\$189 P.C. Power & Cooling, Inc. 31510 Mountain Way Bonsall, CA 92003 (619) 723-9513 Inquiry 1044. |

file queue and print it in background. (I can do all that with my Printer Optimizer, but in fact it's even simpler with Duet.)

Duet will also grab and print a .WKS or .WRK file without Lotus 1-2-3 or Symphony. You can specify a range, define a range, put in headers and footers, and choose sideways or normal printing, as well as specify fonts.

Duet will format a document into a disk file that can later be printed simply by sending it to a laser printer from a computer that doesn't have Duet.

The whole thing is simple to use and gets the job done.

Winding Down

As usual, there's a huge pile of stuff to write about, but I'm out of space. This time one thing is different: this column is so late that I'm going to write the next one tomorrow. Next month, I'll have more on laptops, including the Cam-

bridge Z88 (I'm beginning to like it); Traveling Software's View-Link (wonderful) and Wizard-PC Link, as well as Sharp's Wizard pocket computer itself; a program that lets you do PostScript printing on ordinary laser, ink-jet, and dot-matrix printers; the Northgate keyboards that have become standard at Chaos Manor; and, as the saying goes, much, much more, including my recent trip to Microsoft's annual systems software seminar.

Next month, I'll also have a contribution to the Macintosh Special Edition, so I guess I have my work cut out.

The book of the month is *The Art of David Em: One Hundred Computer Paintings* by David A. Ross and David Em (Abrams, 1988). Em is a fine artist who for years has used a computer to make paintings. He has worked with the Jet Propulsion Laboratory's James Blinn (who did the Saturn fly-by simulations, as well as the computer work for *The Me-*

chanical Universe series.) Em gave a fascinating exposition on his work at this year's annual meeting of the American Association for the Advancement of Science. The book has 100 color paintings and considerable text on the use of computers in the fine arts. The visuals are stunning.

Now for the Macintosh article, then next month's column. It's *work time*. ■

Jerry Pournelle holds a doctorate in psychology and is a science fiction writer who also earns a comfortable living writing about computers present and future. Jerry welcomes readers' comments and opinions. Send a self-addressed, stamped envelope to Jerry Pournelle, c/o BYTE, One Phoenix Mill Lane, Peterborough, NH 03458. Please put your address on the letter as well as on the envelope. Due to the high volume of letters, Jerry cannot guarantee a personal reply. You can also contact him on BIX as "jerry."

Turn your MS-DOS computer into a great programming environment...

C/Utilities Toolchest



The **C/Utilities Toolchest™** adds over 40 powerful UNIX® utilities to your MS-DOS® operating system. The result is an environment very similar to UNIX operating systems, yet 100% compatible with MS-DOS® programs and commands. Besides increasing your productivity, **C/Utilities Toolchest™** gives you a very inexpensive way to learn how UNIX operating systems work.

The **C/Utilities Toolchest™** contains three ready-to-run sets of tools including:

- 1) Text Processing Utilities
- 2) File Management Utilities
- 3) An MS-DOS version of the UNIX Bourne Shell.

The Text Processing utilities include programs like *grep* and *sed* for performing powerful string search and edit operations within text files. File Management includes programs like *mv* and *mkdir* for moving files or whole directories with simple wild-card specifications. The Bourne Shell includes an interactive batch processing language for carrying out detailed operations with a single command.

You also receive a comprehensive 350 page manual containing clear descriptions of the utilities, and lots of example program scripts for use with the Bourne Shell. As an option, we've made the C source code for each set of tools available for use with the **PowerC™**, **Turbo C®**, **QuickC®**, and **Microsoft® C** compilers. Even better, we've made it all very affordable.

Now Only \$19.95!

Order now by calling our toll free number or mail the coupon to:

Mix Software
1132 Commerce Drive
Richardson, TX 75081

1-800-333-0330

60 Day Money Back Guarantee

Not Copy Protected
For technical support, please call:
1-214-783-6001



Order Coupon B

Name _____
 Street _____
 City _____
 State _____ Zip _____
 Telephone _____
 Paying By Money Order Check
 Visa MC AX Disc.
 Card# _____
 Card expires _____
 Disk Size 5 1/4" 3 1/2"

| Qty. | Product | Price | Subtotal |
|-------|--|---------|----------|
| _____ | C/Utilities Toolchest | \$19.95 | \$ _____ |
| _____ | Optional C Source Code | | |
| _____ | Text Processing Utilities | \$10.00 | \$ _____ |
| _____ | File Management Utilities | \$10.00 | \$ _____ |
| _____ | Bourne Shell | \$10.00 | \$ _____ |
| _____ | Add Shipping (\$5 USA, \$20 Foreign) | | \$ _____ |
| _____ | Texas residents add 8% sales tax | | \$ _____ |
| _____ | Total amount of your order | | \$ _____ |

C/Utilities Toolchest and Power C are trademarks of Mix Software. MS-DOS, QuickC and Microsoft C are registered trademarks of Microsoft. Turbo C is a registered trademark of Borland. UNIX is a registered trademark of AT&T.

VGA

A new way to look at color;
a better way to buy it.



MM-1233 12" analog monochrome Grey scale MM-1433 14" analog monochrome Grey scale CM-1496 14" analog color 31mm dot pitch CM-1192 14" analog color 39mm dot pitch CM-1296 12" analog color 28mm dot pitch

Advantages are enhanced by Tatung VGA provides significantly higher resolution. In fact, image clarity is 37% higher than EGA. And while EGA gives you 16 on-screen colors, VGA puts 256 colors (from a palette of 262,144 colors) on a monitor's screen at a time. Distortion, ghosting, and even eye fatigue is sharply reduced. In text modes, characters (even those with descenders like y, p and g) are more clearly defined thanks to a 9 x 16 dot matrix. But, while the monitor is a vital part of a VGA system, we think the real key is the VGA card that goes with it.

The Tatung VGA card is all performance Ours is a 16-bit graphics array board with a single high speed, register compatible, VGA chip...a graphics controller that's incredibly fast (it has a bandwidth more than 7 times that of other VGA boards)! You can access this speed through the 16-bit data path to display memory, BIOS ROM, and I/O. Our exclusive SwiftWrite makes the wait state virtually non-existent. More? With 16 colors, resolution increases to 800 x 600. On-board is a 256K DRAM; and the card is backward compatible with EGA, CGA, MDA and Hercules graphics standards.

Tatung Monitors deliver the new standard We offer the broadest line of VGA monitors available; 5 newly styled and engineered monitors. Each model provides 640 x 480, 640 x 350 lines of graphics resolution; 720 x 400 lines for text. Tatung's new VGA monitors offer a broad range of features that contribute to their superior value: dark, non-glare CRT's, automatic vertical sizing encoding, multi-color text or reverse video switch, 110/220V switchable power supply, removable tilt/swivel bases...all supported by Tatung's full year warranty.

Tatung bundles provide superior value By bundling VGA monitors and cards, Tatung puts VGA within the reach of everyone. In most cases, the Tatung VGA bundle will cost no more than EGA packages! That's why we believe that feature for feature, dollar for dollar, the Tatung VGA bundle represents incomparable value. The kind of value only the largest manufacturer of monitors in the world can deliver.

Tatung offers guaranteed compatibility Whenever a new standard is introduced, system users have a justifiable concern about software compatibility. That's why **Tatung offers a unique guarantee*: if you note any software incompatibilities within the 1 year warranty period, Tatung will correct them free of charge within 30 days, otherwise the full value of the Tatung VGA card will be refunded.**

In addition, Tatung offers users a huge advantage: a Tatung VGA bundle is 100% IBM,™ VGA compatible and more...your investment in software is fully protected.

That's the Tatung VGA story. It's a story worth seeing. For complete information, specifications, and the name of the Tatung dealer near you, and to arrange for a demonstration, call us today. After all, seeing is believing.

Circle 258 on Reader Service Card

NOW AVAILABLE!
New TVGA-8, 8-bit card!



TATUNG
We monitor the world.

In Southern California: (213) 979-7055
In Northern California: (408) 435-0140
Outside California: (800) 421-2929
Tatung Company of America, Inc.
2850 El Presidio Street, Long Beach, CA 90810
Tatung Science & Technology, Inc.
2060 Ringwood Ave., San Jose, CA 95131

Compatible with IBM PC, XT, AT Systems and their compatibles. Refer to Tatung VGA Card Manual for specific details. All details included with each Tatung VGA card. All names trademarks.



SOFTWARE DESPOTISM: TRUTH AND FICTION

Are company software standards being applied too vigorously?

I recently received a truly disturbing letter from a reader. For reasons that will be obvious, I can't disclose this person's name. I've also obliterated references to specific programs.

The person writes: "I've used Product A since I bought my first computer a number of years ago, and I'm now using the latest version. At work, my bosses have required all personnel to use Product B exclusively. If they find another program on your company hard disk, you'll be disciplined. One of my coworkers, who had been with the company for over 12 years, was fired for using Product C on a company machine.

"I still prefer Product A; it's an old, comfortable friend. Though I've become quite proficient with Product B, I still use Product A on my computer at home. I prepare my data on my own equipment, then transfer the information to the company machine at work."

Have we sunk this low? Are goon squads roving the corridors of office buildings late at night, checking hard disks for impure software? Pretty scary.

Look, I understand the need for software standards within a company. A controlled environment reduces the risk of virus infection, software piracy, and data loss. It also enables one employee to finish another's work in an emergency. But healthy caution is one thing, and authoritarian paranoia is another.

Today, most application software packages are amazingly adept at importing and exporting foreign file formats (as my letter writer has discovered). It strikes me as particularly thick-skulled to object when an employee uses an unsanctioned program to prepare rough

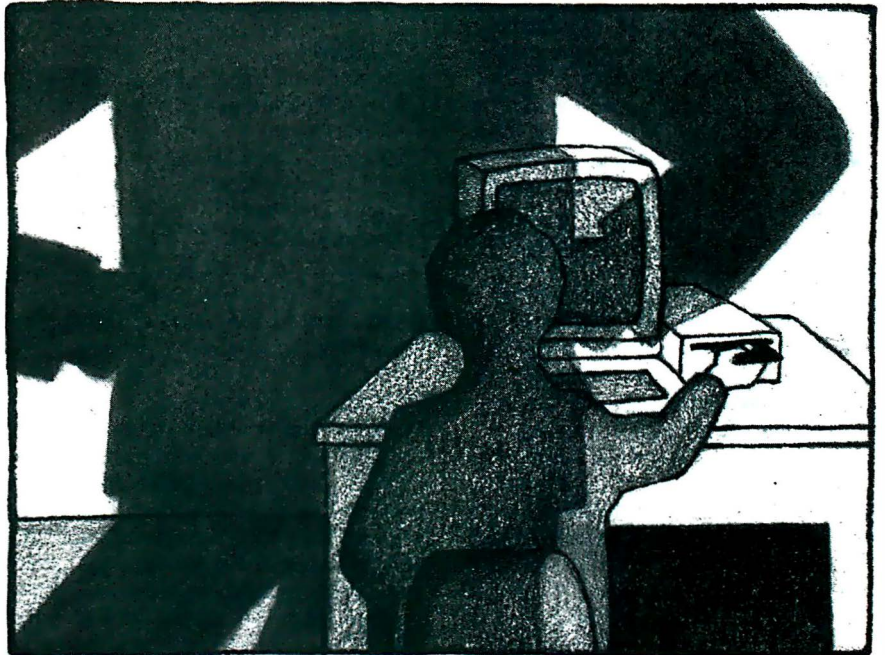

drafts or personal workfiles. As long as a document doesn't require heavy-duty macro programming or sophisticated formatting, what's wrong with opting for employee convenience?

One of the greatest benefits of the personal computer phenomenon is that individuals can customize their environments to accommodate work habits and preferences. Why sacrifice this flexibility? I've heard dozens of horror stories about companies standardizing on software that employees didn't like, but this is the first instance I've encountered of someone being fired based solely on software selection. I'm hoping this is a random incident, rather than the first symptom of a trend, so I'd be interested in hearing about any other cases of bureaucracy running amok. Please let me know about similar experiences.

Simulated Supply and Demand

Back in the early days of this column, I wrote about Balance of Power, Chris

Crawford's game of geopolitical brinkmanship. Though sold as entertainment, Crawford's simulations provide such sharp insight into current events that they're required purchases for anyone interested in the world around us. They are admirably suited for educational institutions as well as individual use. They blend subtle AI technology and the metaphor of game design to reduce complex interrelationships to an easily digested "learn-by-doing" formula. They're important programs.

It took me a certain amount of whining and cajoling to get Crawford to give me a copy of his latest effort roughly a month before it was even ready for beta testing. Neither release date nor price has been set by Mindscape, Crawford's publisher, but the product is real enough for him to be demonstrating it at computer shows. The version I received was buggy, but it was conceptually complete and quite playable. I suspect it will be available late

continued

this summer in a Macintosh version, followed shortly by a port to MS-DOS.

Crawford has delivered another stunner. It's called *Guns & Butter*, and it's based on, of all things, macroeconomics. Before your eyes cross at the thought, let me point out that the academic theories behind the game have been brilliantly translated into strategic elements that require no prior background in the subject. You can learn all you need to know by playing the game.

Here's the scenario: You're the benevolent despot of a country on a computer-generated continent. You have cities, resources, and a population of peasants. At the outset, all your workers are engaged in farming with primitive tools. Your job is to create an industrial economy by tapping your resources, building factories, and manufacturing products. Along the way, you must maximize agricultural efficiency, allocate your labor force, plan your economy, and cope with surpluses and shortfalls.

The incentive for all this activity is competition; you're not alone on the continent. Computerized opponents are busily strengthening their economies, intent on developing military hardware with which to wipe you off the map.

Eventually, the course of events draws you into this arms race. If you don't manage your country's growth successfully, you'll be invaded. On the other hand, if you're a canny planner, you can stock your arsenal and march off to conquer the world. Thus, *Guns & Butter* combines both economics and military tactics; the result is mesmerizing.

Guns & Butter is not an exact simulation; corners have been cut to make it playable. Output is limited to industrial and military goods; you don't have to worry about housing or clothing your population. Your military is limited to conventional ground forces—tanks and howitzers, but no airplanes.

Guns & Butter will probably offend theoretical purists; some will attack the underlying algorithms as Marxist in nature, while others will argue that the game is not Marxist enough. In truth, the game does allow for economic experimentation, and the lessons you'll learn are generalized enough to give you an understanding of the basic underpinnings of political economics.

Once again, Crawford has given us a program to delight people of all ages. He has provided entertainment that doesn't involve blasting aliens or chasing gorillas up ladders. I urge educators to make a place for *Guns & Butter* on the shelves of our high school social science class-

ITEMS DISCUSSED

Allways\$149.95
 Funk Software, Inc.
 222 Third St.
 Cambridge, MA 02142
 (617) 497-6339
Inquiry 1021.

Guns & Butter Not priced yet
 Mindscape, Inc.
 3444 Dundee Rd.
 Northbrook, IL 60062
 (312) 480-7667
Inquiry 1022.

IS/ADB
 with corded pen\$595
 with cordless pen.....\$695
 Kurta Corp.
 3007 East Chambers St.
 Phoenix, AZ 85040
 (602) 276-5533
Inquiry 1023.

rooms, next to the copies of *Balance of Power* that should already be there.

Spreadsheet Ecstasy

Let's say you're a die-hard Lotus 1-2-3 user, but you've been having conniptions trying to print Lotus worksheets on your laser printer, and you've been drooling at Microsoft Excel's formatting capabilities. However, let's also say you don't want to shell out the bucks for a new software package, you don't want to train yourself or your staff to the idiosyncrasies of a different spreadsheet program, and you have no desire to re-debug all your macros in the process of converting your files from Lotus 1-2-3 to Excel.

So do you know about Allways, the latest utility from Funk Software? This company brought you Sideways, the grandfather of all spreadsheet printing utilities. And this new \$149.95 program may well be the answer to your prayers.

Designed as an add-in module for versions 2.0 and 2.01 of Lotus 1-2-3, Allways is a superb spreadsheet formatter. With Allways, you can use up to eight typefaces on most popular dot-matrix and laser printers, including PostScript and PostScript-compatible devices. On a graphics monitor (i.e., CGA, EGA, or VGA), you get a WYSIWYG display, similar to the page-preview mode available in many of the newer output-oriented programs. (The program will also work just fine with a character-based monitor, but you can't see the fonts.)

Allways lets you specify type style by cell or by range, add boxes and under-

lines, change column widths and row heights, and even include .PIC charts and graphs inside a worksheet printout. You can get access to any of your printer's built-in hardware fonts, support for Hewlett-Packard LaserJet Plus and Series II cartridges, and three soft fonts (Times, Courier, and a Helvetica called Triumvirate), so dot-matrix printer owners won't feel neglected.

When I hooked Allways up to my Okidata Microline 192, it performed impressively. But for the real torture test, I hauled the Tandon IBM PC AT clone into the room where the Apple LaserWriter IINT printer lives, disconnected AppleTalk, plugged in a serial cable, and let her rip. The IINT is a great printer, with solid blacks and crisp edges, and the combination of Allways and the IINT was good enough that I couldn't tell that printout had been prepared on a computer that wasn't a Mac.

About the only frustration I can see with using Allways would be if you've spent hours and hours writing convoluted printer-control macros; I can guarantee that you won't ever use them again. There's not much more to say. Allways works, it's inexpensive, and it will prolong your allegiance to Lotus 1-2-3 for a while longer. Highly recommended.

The Search Goes On

I continue to hunt for the perfect alternative to the mouse. Back in the days before Apple's Lisa, there was a lot of discussion about pointing devices. Nobody was too sure the mouse was the best idea. Well, the little rodents seem to have won the marketing battle for the moment, but I steadfastly maintain that the issue is still not resolved.















I'm hoping that by endorsing mice without bothering to include them with the PS/2s, IBM has pumped some new blood into the marketplace. Though I'm running out of options from the products available today, I'm hoping we'll see more possibilities come to life in the next few years.

My latest acquisition is a digitizing tablet from Kurta. The tablet I tested came with two pens: one with a cord, and one that communicates to the tablet by means of a teeny radio transmitter in the top of the barrel. This gizmo is hot stuff, perfect for anyone who has despaired of generating freehand drawings with a personal computer.

You still can't get quite the feel you can achieve with a traditional medium, largely because of the internal human mechanism of eye-hand coordination.

continued

TAKE CHARGE!® DOES WHAT ALL THESE DO AND MUCH MORE... INCLUDING TASK SWITCHING

| | | | | |
|---|---|--|---|---|
| SIDEKICK PLUS  \$199.95 72K | DISK OPTIMIZER  \$69.95 256K | AUTOMENU  \$50.00 30K | PC TOOLS DELUXE 5.0  \$79.00 40K | DIRECT ACCESS  \$89.95 256K |
| CRUISE CONTROL  \$59.95 4K | METRO  \$85.00 64K | Q DOS  \$79.95 128K | XTree professional  \$129.00 100K | NORTON UTILITIES ADVANCED  \$150.00 256K |
| SOFTWARE CAROUSEL  \$79.95 32K | NORTON COMMANDER  \$89.00 145K | COMMUNICATIONS  \$100.00 100K | MACE  \$99.00 192K |  Take Charge! \$139.95 20K |

IN ONLY 20K OF RAM!

This power packed integrated program lets you Take Charge! of your PC with every memory resident program you will ever need, plus Configure-IT, the Take Charge! Task Switching Manager. Lets you run your favorite programs as pop ups from within another running application program with the use of a hot key. Pop up word processing from within your Data Base Management program. Go from Lotus 123 to any other program and back, all within 20K of RAM. While using such Take Charge! features as a Full featured **Menu System** that enables you to run all the software on your PC with just one key stroke. A **Disk Optimizer** to speed up your hard disk. **Undelete** for files accidentally deleted. **Format Recovery** for those accidentally re-

formatted hard disks. **File Locator** to quickly find any file anywhere on the hard disk. A complete **Communications package** for communicating with other PC and BBS. View and work in multiple directories with **Split Screen** facility. A full featured **Dos Shell** with **Graphic Tree Directory** display. Copy, move and delete files quickly. Pop up **Calculators**, full screen **Editor** with unlimited file size, **Notepad/clipboard**, **ASCII**

table, **Rolobase** with **autodialer**, **Appointment book** and **calendar**. **Cut-and-paste** between applications. Set the **Alarm** clock to remind you of appointments. Lock your Keyboard with your own security code. Set the **Clock** to display on the screen. Set the **Screen Saver** to automatically turn off the CRT display. Change on screen colors. Redirect printer output. Use the **Speed Key** to increase cursor speed. Plus **Disk Test**, **Disk Map**, **Directory Editor**, **Hex Editor**, **Directory Sort**, **DOS 4.0** and **Compaq DOS 3.31** support. **\$139.95**

Take Charge!
 LIKE NOTHING IN RECENT MEMORY

SPECIAL \$99.95 Includes our New Hard Disk Back Up Program **FREE**. Works in background mode, unattended & automatic-backs up data while you work without interruption.

Call your local Dealer, or write: Departmental Technologies, Inc /13 Kilroy Rd., Newton, NJ 07860
 Tel: (201) 786-6878 / FAX: 201-786-5868 / Major Credit Cards Accepted, Dealer Inquiries Welcomed

System Requirements: IBM™ PC, XT, AT, PS/2, or 100% IBM compatible. Requires hard disk. MS/DOS 2.0 or greater. 320 K minimum. Network compatible. Product RAM estimated. All product names are trademarks of their manufacturers. Copyright 1988. Departmental Technologies, Inc. All rights reserved.

Circle 79 on Reader Service Card

However, this is about as close as you'll get without busting your bank account. Digitizing tablets are not as cheap as mice, trackballs, and joysticks, but the expense is worth every penny if you're serious about your artwork.

The unit I'm testing is the IS/ADB model for the Mac, but you can get identical features for your IBM PC with Kurta's IS/One line. The IS/ADB has an active area of 12 inches by 12 inches, which means the whole thing is more like 15

inches by 16 inches. There's a margin of an inch or so on all sides, and Kurta includes a sensitized strip at the top of the tablet, separate from the drawing area, which has configuration options and 13 function "keys" that are mapped to the function keys on the regular keyboard. The tablet therefore occupies a good deal more real estate than a mouse, and I've had to redesign my work area once again in order to use the thing.

I've found I prefer the corded pen to

the optional cordless pen. The cord is a minor annoyance, and the response feels quicker than that of the cordless pen, which requires a heavier hand to operate. If you're doing precision tracing or CAD work or using the digitizing tablet as a programmed input pad, you can also purchase corded and cordless cross-hair cursors from Kurta. All this stuff is sold with a lifetime guarantee, and it all performs without a hitch.

This is the most sophisticated, best-designed, and most accurate of all the devices I've come across in the past few months. On the other hand, it's the most expensive and most desktop-hungry. I think it's one of those products that sells itself; if you suspect you need one, you need one, so go out and buy it.

Here are my reactions to everything I've tried. First, the mouse. Trini Cemo of Kurta gave me the best line I've ever heard on the subject; she said that drawing with a mouse "is like drawing with a bar of soap." Extensive mouse use hurts my elbow, the little Teflon pads on the mouse wear off, and you lose a square foot of desk area. But mice are cheap (they come free with the Mac) and relatively efficient for nonartistic applications.

Trackballs are a step up, though I find them better suited to CAD than to free-hand drawing. They're fine for routine operations, take less space than mice, and cost about the same. But I'm not sure about longevity. Though my MicroSpeed unit for the PC has never failed, I've already had to replace the Abaton trackball for the Mac once.

The joystick offers better control than mice and trackballs for games and drawing, but it loses to the tablet on CAD. I'd love to see a high-end joystick someday, with a thin stick rather than a pistol grip and a contoured base with a wrist rest. But so far, no manufacturer has decided to produce a mass-market model of this idea.

There you have it. Conclusion drawn from this exercise? Simply this: Don't think you have to use a mouse because they're ubiquitous right now; other devices are available, and they might better match your requirements. ■

Ezra Shapiro is a consulting editor for BYTE. You can contact him on BIX as "ezra." Because of the volume of mail he receives, Ezra, regretfully, cannot respond to each inquiry.

Your questions and comments are welcome. Write to: Editor, BYTE, One Phoenix Mill Lane, Peterborough, NH 03458.

PC Voice Mail, now only \$199.

For an ear-opening telephone demo call:
1-800-6-WATSON Ext. 127

Now get a *combined* PC-based voice mail, data modem, and telephone answering system—from only \$199. With Watson, you'll *profitably* improve your business communications with clients, colleagues, sales and service reps, field staff, vendors.

Benefits Of A \$20,000 + Voice Messaging System Or "Personal Receptionist" For As Low As \$199

Look at all of these advanced features:

Voice Mail—Watson's automatic telephone answering lets callers leave and receive messages of any length 24 hours a day, 7 days a week. Ends "telephone tag" with clients and colleagues. Forwards messages automatically to mobile phones and pagers. Retrieve messages from any touchtone phone—even a car phone. Never miss an important call! And Watson provides "big system" professional sound quality!

Up To 750 Private "Mailboxes"—Give up to 750 of your colleagues or clients an individual, confidential "voice mailbox." Use them to receive private messages or record special messages for individual callers.

Electronic Telephone Book—In one keystroke, access any of up to 750 telephone numbers, then use automatic dialing and re-dialing if busy. Store key information on contacts and get it immediately when you need it.

Hayes-Compatible Data Modem—Comes complete with 1200 BPS Hayes-compati-

ble modem (or optional 2400 BPS modem). Transfer your data files and access Telex, E-Mail, Dow Jones, or other public databases.

Simultaneously Run Popular Business Programs—Run programs such as Lotus 1-2-3 while Watson records or delivers messages.

Plus—Watson efficiently guides callers through the options they have in leaving messages... Delivers special pre-recorded messages to individuals at pre-determined times... Automatically forwards messages to other telephone lines or numbers... Provides an electronic calendar with automatic alarms and telephone notification.

30-Day Risk-Free Trial Installation

Try Watson for 30 days. If you aren't 100% satisfied, send it back for a prompt and full refund. No questions asked.

Demo Hotline

For a telephone demo call 1-800-6-WATSON EXT. 127 (in MA 1-508-651-2186 EXT. 127). Tell us EXT. 127 and receive a *free* five pack of diskettes if you purchase.

Order Hotline

To order Watson call 1-800-533-6120 EXT. 127 (in MA 1-508-655-6066 EXT. 127). Tell us EXT. 127 and receive a *free* five pack of diskettes with purchase. Price: \$199. For optional 2400 BPS modem add \$100. MasterCard, VISA, and American Express accepted. Credit card or check must accompany order.



Watson®

Natural MicroSystems Corporation, 8 Erie Drive, Natick, MA 01760-1313

OVER 30,000 SOLD

WHETHER REPORT.

Whether you're a software developer writing new applications for the IBM or Mac, or a PC user securing proprietary data files, software and data protection has never had a brighter silver lining. For a number of very good reasons.

Beginning with the 'whether-expert' Rainbow Technologies. And ending with its Software Sentinel family of hardware keys. Starring five models that fit virtually any software program or data file you need to protect.

There's the best-selling SentinelPro for the IBM PC/XT/AT, PS/2 and compatibles, and even the Atari ST. Known worldwide for its virtually unbreakable security. And its ASIC technology. And its invisible operation. A close relation, the Sentinel-C stands at-the-ready for custom configurations and multiple software packages.

In the Apple market, security-minded Mac software developers turn to Eve. For completely transparent operation and world-class security of the protected software. Just by plugging Eve into the Mac ADB connector.

PC users wanting a low cost, user-friendly solution to the problem of securing sensitive data can call on the DataSentry. Using a proprietary Rainbow algorithm or DES, the DataSentry encrypts data files on individual PCs, protects modem transmissions and secures data on local area networks.

Rainbow's latest protection strategy is the SentinelShell—that lets users place a 'shell' around existing, off-the-shelf programs. Because access can be limited to those issued a key, libraries, universities and corporations can very simply guard their software investments.

Whatever your whether, Rainbow Technologies has the software and data protection products that make the difference. For more information, call 714-261-0228 in the U.S., or contact Rainbow Technologies Ltd. in the United Kingdom for the distributor nearest you. Whethercasters are standing by.

SentinelPro™

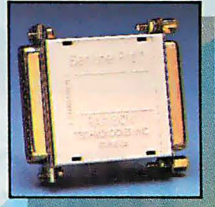

- Runs under DOS, OS/2 and Xenix
- Algorithm technique (Never a fixed response)
- External parallel port installation
- Minimal implementation effort
- Higher level language interfaces included
- 100 times faster than fixed-response devices (1 ms)
- ASIC design for reliability

Sentinel-C™



- Protects multiple packages with one device
- 126 bytes of non-volatile memory programmed before shipment of the software
- Rainbow supplies a unique adapter for programming the unit
- Higher level language interfaces included
- Runs under DOS, OS/2 and Xenix
- External parallel port installation

Eve™



- For the Macintosh SE and II
- Complies with Apple Desktop Bus Interface requirements
- Rainbow-assigned developer passwords to prevent tampering by other developers or sophisticated "hackers"
- 7 locks per key, usable individually or in combination, on one or up to seven applications

DataSentry™



- Completely user-installable
- Pocket-sized external device
- Menu-driven, user-friendly interface
- Single- or multi-user security system
- Audit trail, log-on identifiers and automatic encryption/decryption of entire directories
- Secures data transmitted by modems
- Prevents recovery of data by utility programs

SentinelShell™

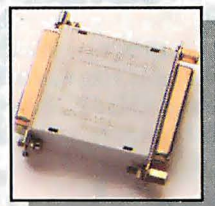

- Runs under DOS on IBM PCs and compatibles
- Protects without requiring access to the source code
- Completely transparent to the end user
- User-friendly software
- Pocket-size key attaches quickly to any standard PC parallel port
- ASIC design for reliability



RAINBOW TECHNOLOGIES

18011-A Mitchell South, Irvine, CA 92714 • (714) 261-0228 • TELEX: 386078 • FAX: (714) 261-0260
Rainbow Technologies, Ltd., Shirley Lodge, 470 London Rd., Slough, Berkshire, SL3 8QY, U.K., Tel: 0753-41512, Fax: 0753-43610

© 1989 Rainbow Technologies. All product names are trademarks of their respective manufacturers.

Circle 231 on Reader Service Card (DEALERS: 232)

Quarterdeck

DESQview 2.2 and DESQview 386. The multitasking, windowing environments that work with your favorite software.

DESQview™ is the operating environment that brings OS/2™ power to DOS. And it lets you, with your trusty 8088, 8086, 80286, or 80386 PC, leap into the next generation in PC productivity. For not much money. And without throwing away your favorite software.

Introducing DESQview 2.2

And now, DESQview 2.2 adds capabilities, performance, and compatibility enhancements you've been asking for.

Like being able to fine tune DESQview performance "on the fly." Run Lotus Express and Metro. And the Intel Connection Co Processor. Even use the DOS 4.0 shell with DESQview. Have DESQview automatically install Quattro, Sprint, Aldus PageMaker, Microsoft Excel, Word Perfect, Database and as many as 80 other programs. And using the DESQview API, be able to dynamically link them.

More bang; less bytes

While other programs get bigger, we've worked to make DESQview smaller. And we've succeeded in a big way on PCs and PS/2™s with extended, EMS 3.2 (AboveBoard), EEMS and EMS 4.0 memory—as well as on 386 PCs and



DESQview lets you run your favorite programs in windows side-by-side.

PS/2s. For example, DESQview overhead on EMS 4.0 and 386 PCs can be as low as 10K on EGA/VGA PCs. And DESQview actually *increases* memory 30K on CGA PCs; 20K on monochrome and Hercules PCs. That's good news for users of big desktop publishing, CAD and database programs.

Introducing DESQview 386

For users of 80386 PCs and PS/2s (or PCs with 80386 add-in boards, such as the Intel Inboard 386), there's DESQview 386 (a combination of DESQview 2.2 and the new QEMM-386

Quarterdeck Expanded Memory Manager, version 4.2).

DESQview 386 gives you extraordinary power. Run text, CGA, EGA, VGA, and Hercules programs in

windows and in the background. Run 32-bit 386 programs, like Paradox 386, and IBM Interleaf simultaneously with your favorite DOS programs. All with the speed and performance you expect out of your 386. And with protection against 'misbehaved' programs.

Promise and performance

And, of course, both DESQviews have all the features that made prior versions the popular choice in operating environments. The ability to multitask in 640K and beyond. View programs in windows or full screen. Transfer data. Access DOS via menus. Dial your phone. And create key-stroke macros within and between programs.

Our story gets better and better

If there's any doubt about our commitment to your PC and PS/2 productivity, just look at our accomplishments over the years. We think you will understand why GE, Ford, Aetna, Monsanto, and so many other major corporations use DESQview.

And why PC Magazine gave DESQview its Editor's Choice Award for "The Best Alternative to OS/2," why readers of InfoWorld twice voted DESQview "Product of the Year," why, by popular vote at Comdex Fall for two years in a row, DESQview was chosen "Best PC Environment" in PC Tech Journal's Systems Builder Contest.

DESQview lets you have it all now.



Quarterdeck Delivers.

QEMM. Break the 640K barrier for \$59.95

Your 80386 PC, IBM Personal System/2 Model 80, PC or AT with 80386 add-in board, as well as your IBM Personal System/2 Models 50 or 60 can all break through the DOS 640K barrier. Now you can have maximum use of your memory—whether you have one megabyte or 32—with the Quarterdeck Expanded Memory Manager. All without having to purchase special expanded memory boards.

QEMM uses hidden features within your existing memory to make it compatible with the Lotus-Intel-Microsoft Expanded Memory Specification (EMS) version 4.0.



Now you can run colossal spreadsheets, databases, and CAD models designed for expanded memory, using Lotus 1-2-3, Symphony, Framework, Paradox, AutoCAD, Excel and more.

And if you'd like to use these programs all together—multitasking beyond 640K—QEMM works with our popular DESQview multitasking environment.

If you are one of the 12 million or so 8088, 8086 or 80286 PC users who feel left out, don't despair. We have options that let you keep your computer and favorite programs and give you today what the newest PCs and operating systems are promising for the future.

Visit your dealer for more information on barrier-breaking Quarterdeck products.

DESQview API Toolkit. New C and Pascal Libraries, Debugger, Panel Designer. And more.

**DESQview API
Conference '89**
Coming in August
Write for details

API Reference Manual

The key to the power of the DESQview API, our Reference Manual contains all you need to know to write Assembly Language programs that take full advantage of DESQview's capabilities. And there's an 'include' file with symbols and macros to aid you in development.

API C Library

Here are C language interfaces for the entire set of API functions. It supports the Lattice™ C, Metaware™ C, Microsoft® C, and Turbo C compilers for all memory models. Included with the C Library package is the API Reference Manual and source code for the library.

API Pascal Library **NEW!**

The Pascal library provides interfaces for the entire set of API functions. It supports Turbo Pascal V4.0 and V5.0 compilers. Included are the API Reference Manual, source code for the library, and example programs.

API Debugger

The DESQview API Debugger is an interactive tool enabling the API programmer to trace and single step through API calls from several concurrently running DESQview-specific programs. Trace information is reported sym-

bolically along with the program counter, registers, and stack at the time of the call. Trace conditions can be specified so that only calls of interest are reported.

API Panel Designer

This interactive tool helps you design windows, menus, help screens, error messages, and forms. It includes an editor that lets you construct an image of your panel using simple commands to enter, edit, copy, and move text, as well as draw lines and boxes. You can then define the characteristics of the window that will contain the panel, such as its position, size, and title. Finally, you can specify the locations and types of fields in the panel.

The Panel Designer automatically generates all the DESQview API data streams necessary to display and take input from your panel. These data streams may be grouped into panel libraries and stored on disk or as part of your program.

More Tools are Coming

Quarterdeck is committed to adding tools as needed by our users. To that end we have been working with Ashton Tate and Buzzwords International on dBASE III and dBASEIV translators. And in the works, we have BASIC and DOS Extender libraries.

Quarterdeck

Quarterdeck Office Systems, 150 Pico Blvd., Santa Monica, CA 90405 (213) 392-9851
FAX: (213) 399-3802

For additional information, please use the following Reader Service numbers: DESQview: 222 QEMM: 223 API Tools: 224 API Conference: 225

Leprecard Disk Cards for PC & AT Computers

Shamrock's Leprecards feature the latest low power, high reliability disk drives and controllers. You can use them as the first or second hard disk in your system. Low power consumption means less strain on your system. You get a 1 year warranty, unlimited technical support, & our illustrated installation and user's guide. Models available for IBM PC/XT and compatibles, AT's and compatibles, as well as the TANDY 1000/A/SX/TX/TL/SL. **FREE SOFTWARE** including TakeTwo, the backup utility PC MAGAZINE named Editors choice in 1986 & 1987, & LepreCache disk cacheing from Multisoft.

TakeTwo



| COMPUTER TYPE | 21MB 40MS | 32MB 40MS | 49MB 28MS | 65MB 16MS |
|---------------|--------------|--------------|--------------|--------------|
| 8 BIT PC/XT | \$299 | \$319 | \$549 | \$649 |
| 16 BIT PC/AT | N/A | \$379 | \$599 | \$679 |

| HIGH PERFORMANCE SCSI DRIVES | 32MB 40MS | 49MB 40MS | 60MB 24MS | 84MB 24MS |
|---------------------------------|--------------|--------------|--------------|--------------|
| | \$449 | \$549 | \$689 | \$829 |

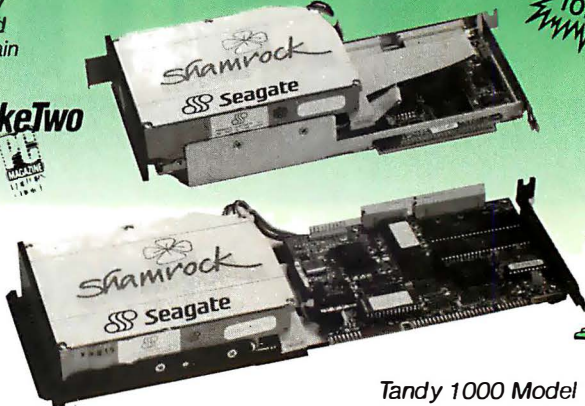

NOW
for AT



Tandy 1000 Model

Seagate PC/XT Disk Kits

- Pretested & formatted
- Western Digital short slot controller
- 30 page installation guide & reference manual
- Cables, mounting screws, full & half-height face plates
- FREE! TakeTwo high speed backup software, PC MAGAZINE "Editors Choice"
- FREE! LepreCache software by Multisoft
- 1 year Warranty, 30 Day Money Back Guarantee
- Optional: 150 Watt, UL/FCC approved power supply for IBM PC's \$69

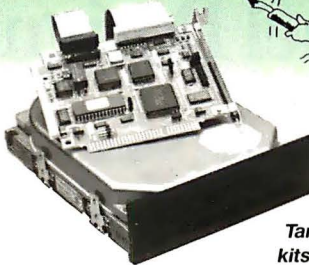

Tandy 1000 kits add \$20

30MB KIT \$299

- Seagate ST238 - 32.7MB/65ms/Half-Height/14.8 watts

65MB KIT \$499

- Seagate ST277R - 65.5MB/28ms/Half-Height/11 watts



Seagate 20MB \$249
40MB \$349

Matched Pair Kits

- Seagate Drive & Matched Controller
- 1 year factory warranty
- 15% faster throughput than ST251 drive

NEW

NEW

Leprekeys Calculator Keyboard

\$89

- 111 Key enhanced layout
- Built-in Solar Powered Calculator
- Switchable Ctrl, Capslock keys
- Double injection molded key caps
- Removable function key template
- ALPS tactile keyswitches as used by Northgate
- 100% PC/XT/AT/386 & Novell network compatible



AT Disks

- Seagate Drive with IBM AT rails & cables
- FREE! OnTrack large drive software
- FREE! LepreCache & TakeTwo backup software
- Formatted, Partitioned & Tested

| Size | Model | Speed | Format | Capacity | Price |
|------|---------|-------|--------|----------|-------|
| HH | ST251 | 40ms | MFM | 48MB | \$359 |
| HH | ST251-1 | 30ms | MFM | 42MB | \$449 |
| HH | ST277R | 40ms | RLL | 65MB | \$449 |
| FH | ST4096 | 28ms | MFM | 80MB | \$599 |

286/386 Computers

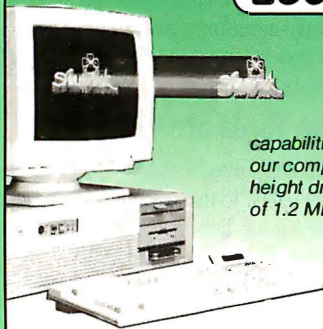

SHAMROCK Computers give you the maximum in performance and value.

Our data crushing systems come standard with high performance SCSI disk interfaces. This gives you the data transfer capabilities required by this high performance generation of systems. All our computers have 8 slot motherboards, room for 1 full and 3 half-height drives, serial/printer ports, AWARD BIOS, clock/calendar, choice of 1.2 MB or 1.44 MB floppy drive, and LepreKeys Enhanced Keyboard with tactile switches and built-in solar calculator. Our 286 systems feature 12 & 16 MHz processors and 512K RAM standard, upgradable to 4 MB on system board.

Our 386 systems offer 16 & 20 MHz processors and 1 MB RAM standard, upgradable to 8 MB. A 64K static column RAM cache operating at 35 nanoseconds insure maximum processor performance.

And don't forget that when you buy from Shamrock you get a 1 year warranty and 30 day money back guarantee.

| SYSTEM | NORTON SI V4.0 | MIPS | PRICE |
|------------------------|----------------|------|---------|
| IBM Model 50Z | 11.2 | 1.6 | \$2,995 |
| Shamrock 286-12/1 wait | 11.8 | 1.9 | \$ 799 |
| Shamrock 286-12/0 wait | 15.3 | 2.5 | \$ 888 |
| Shamrock 286-16/1 wait | 15.9 | 2.6 | \$ 899 |

| SYSTEM | NORTON SI V4.0 | MIPS | PRICE |
|------------------------|----------------|------|---------|
| Compaq 386-16 | 15.6 | 2.8 | \$3,995 |
| Shamrock 386-16/0 wait | 18.7 | 2.8 | \$1,799 |
| Shamrock 386-20/0 wait | 24.4 | 4.3 | \$1,999 |



733-AA Lakefield Rd., Dept. B,
Westlake Village, CA 91361

to order or get our free catalog, call

TOLL FREE
800-722-AT-XT

California
(805) 373-7847

FAX
(805) 379-9345



- No extra for Visa/Master/Discover (AMEX add 3%).
- Prices include UPS surface shipping.
- Federal Express shipping just \$1.50 per pound.
- 30 Day money back guarantee.
- Corporate & Institutional P.O.'s accepted.
- Call for our FREE CATALOG.



UNCOMMON COMMONALITY

A few smart companies let you use the same software on different machines

Her analysis complete, consultant Leslie Scott presses the F7 key on her personal computer to tell WordPerfect to save the document. A few minutes later, Scott transfers the document to her company's VAX 8650 computer, giving her project team access to it so that the final document can be assembled for delivery to the client. After she has completed the transfer, Scott again calls up WordPerfect to look at another document—but this time she calls it up on the VAX.

The most noticeable difference between the microcomputer and minicomputer versions of WordPerfect is the slight delay in screen response due to the relatively slow 2400-bps transmission speed used by the VAX. Otherwise, everything looks the same, and the keystrokes are nearly the same. To run WordPerfect on the VAX, Scott is using a terminal emulator called the EM-220, which remaps the emulated VT-220 keyboard into one closely resembling the keyboard used by the personal computer version of WordPerfect.

Common Software

Leslie Scott is the beneficiary of a relatively new trend in business software that provides for a common user interface on vastly different computers. In this case, the common user interface is provided by different versions of the same software. WordPerfect Corp. has gone to great lengths to make its product look and work alike on different platforms. In addition, these products all support the same data formats, so that a file created on the VAX can be used on the personal



computer without conversion.

While WordPerfect Corp. is certainly the leader in this trend, it is hardly alone. Last year, for example, Lotus Development Corp. announced that a version of its popular 1-2-3 spreadsheet was being developed for IBM mainframes. Lotus has yet to deliver on this product, but two other companies have not waited. Mosaic Software and The Santa Cruz Operation have both begun shipping Lotus-compatible products that run in Unix and Xenix environments.

Choose Your Partner

Finding compatible software that will cross system boundaries can be tricky. For example, not every Unix system will support a 1-2-3 clone. In addition, you have to decide what level of compatibility you need.

There are two levels of compatibility to consider when choosing these packages. The first involves the user interface, and the second concerns the data.

In some cases, only one or the other is enough.

A common user interface eliminates retraining for the use of different platforms, and it greatly reduces error. People become accustomed to a single way of doing things, and they are not required to change when they use different computers. As more companies incorporate personal computers into their operations and begin to use them in place of terminals to connect with their mainframes, this elimination of retraining becomes significant in reducing costs.

The ability to use a common data format is a significant time saver as well. While a number of programs will convert one word processing or spreadsheet format to another, these conversion programs do not always do a complete job; you have to go through the file and clean up the places where the software failed in the conversion. This is especially the case with word processing programs,

continued

ITEMS DISCUSSED

EM-220\$189
 Diversified Computer Systems
 3775 Iris Ave., Suite 1B
 Boulder, CO 80301
 (800) 247-3834
 (303) 447-9251
Inquiry 981.

FoxBASE+\$395
FoxBASE+ LAN.....\$595
FoxBASE+ 386\$595
FoxBASE+ Mac\$395
FoxBASE+ Mac Multiuser...\$595
 Fox Software, Inc.
 118 West South Boundary St.
 Perrysburg, OH 43551
 (419) 874-0162
Inquiry 982.

Lotus 1-2-3M
 (price not yet available)
 Lotus Development Corp.
 55 Cambridge Pkwy.
 Cambridge, MA 02142
 (617) 577-8500
Inquiry 983.

SCO FoxBASE+\$795 to \$995
SCO Xenix\$595 to \$795
AT&T 3B2.....\$1295 to \$2495
IBM RT PC\$1495
NCR Tower\$1295 to \$2495
Sun-3\$1295
SCO Professional.....\$795 to \$895
 The Santa Cruz Operation
 400 Encinal St.
 Santa Cruz, CA 95061
 (408) 425-7222
Inquiry 985.

Twin.....\$99
Twin Advanced\$149
Twin Level III.....\$249
Twin/UX:
AT&T\$495 to \$1195
SCO Xenix\$695
Microport\$695
Prime EXL.....\$1995
Microsoft\$695
 Mosaic Software, Inc.
 1972 Massachusetts Ave.
 Cambridge, MA 02140
 (617) 491-2434
Inquiry 984.

WordPerfect 5.0\$495
WordPerfect Mac.....\$395
WordPerfect Amiga.....\$329
WordPerfect VMS.....\$600 to \$29,000
WordPerfect Data
General\$1800 to \$16,500
WordPerfect 370.....\$6000 to \$20,000
 WordPerfect Corp.
 1555 North Technology Way
 Orem, UT 84057
 (801) 225-5000
Inquiry 986.

which seem to have incompatible formats intentionally.

WordPerfect

WordPerfect is one of the best examples of software that supports multiple platforms well. It runs on IBM PC clones and the VAX, as I've mentioned. It also runs on IBM 370 architecture mainframes, Data General minicomputers, Apples, Commodore Amigas, and Atari STs, among others. In all cases, the data is compatible. If you create a file with WordPerfect version 4.2 on the PC, you can use that file on the VAX or the Macintosh.

User interfaces are compatible for the most part. The screen of the PC version of WordPerfect looks just like the one used by the VAX version or the Data

General version. There are exceptions. The Macintosh version uses the Macintosh interface, for example.

WordPerfect Corp. has stated a goal of continuing the spread of its software to additional platforms. Already there are LAN versions of WordPerfect, and additional Unix versions are on the way.

Lotus Clones

Lotus 1-2-3 remains the top-selling business software in history. At this writing, however, there is only one version of that popular spreadsheet, and it runs on the IBM PC and compatibles. While Lotus has announced that an IBM mainframe version is in the works, there's no indication from Lotus when that will be forthcoming. In addition, Lotus said that it has no plans to develop software for other

environments. It is this dearth of support on non-PC systems that has brought forth the clone makers.

One of the most ambitious makers of 1-2-3-compatible products is Mosaic Software. This company makes a variety of products for IBM PC clones, including one called Twin Level III that anticipates the long-awaited Lotus 1-2-3 version 3. In addition to its PC products, Mosaic says it will soon have versions of Twin for Unix and Xenix systems, and for the Macintosh as well. All these products will have the same user interface and will share the same data in the Lotus 1-2-3 format.

The Santa Cruz Operation, maker of the popular SCO Xenix, has also entered this segment of the market with SCO Professional. This product is compatible with 1-2-3 version 2.01 and has an identical user interface. SCO Professional works only with SCO Xenix, but that's not a great hardship, considering SCO's popularity.

These packages allow a user trained on the PC to use packages on a Unix-based multiuser system. They also let you create a spreadsheet file on your PC at home and send it to the office system when you get to work.

Back to dBasics

Another extremely popular package, dBASE III Plus, has the clone makers busily creating new versions. In one case, the resemblance was so great that Ashton-Tate boss Ed Esber sued Fox Software of Perrysburg, Ohio, as soon as he saw its version. Esber also had his lawyers sue SCO for manufacturing something called SCO FoxBASE+, a dBASE clone for Xenix.

One strong point of the SCO product is the ability to add dBASE language compatibility to a Xenix system. Of course, the user interface is essentially identical to that of dBASE. That's what made Esber so angry. In addition, FoxBASE+ is completely compatible with dBASE databases. All this compatibility means that you can create systems on a personal computer and then run them on a multiuser Xenix system.

While SCO markets the Xenix version of FoxBASE+, Fox Software has written its program for the Macintosh. Like its Xenix cousin, the Macintosh software will support dBASE language programs and use dBASE databases.

There was once a time when the rumor mill talked of a Unix version of dBASE from Ashton-Tate, but it never materialized.

continued

BEST VALUE PRINTER

Order today — try it FREE for 30 days.*

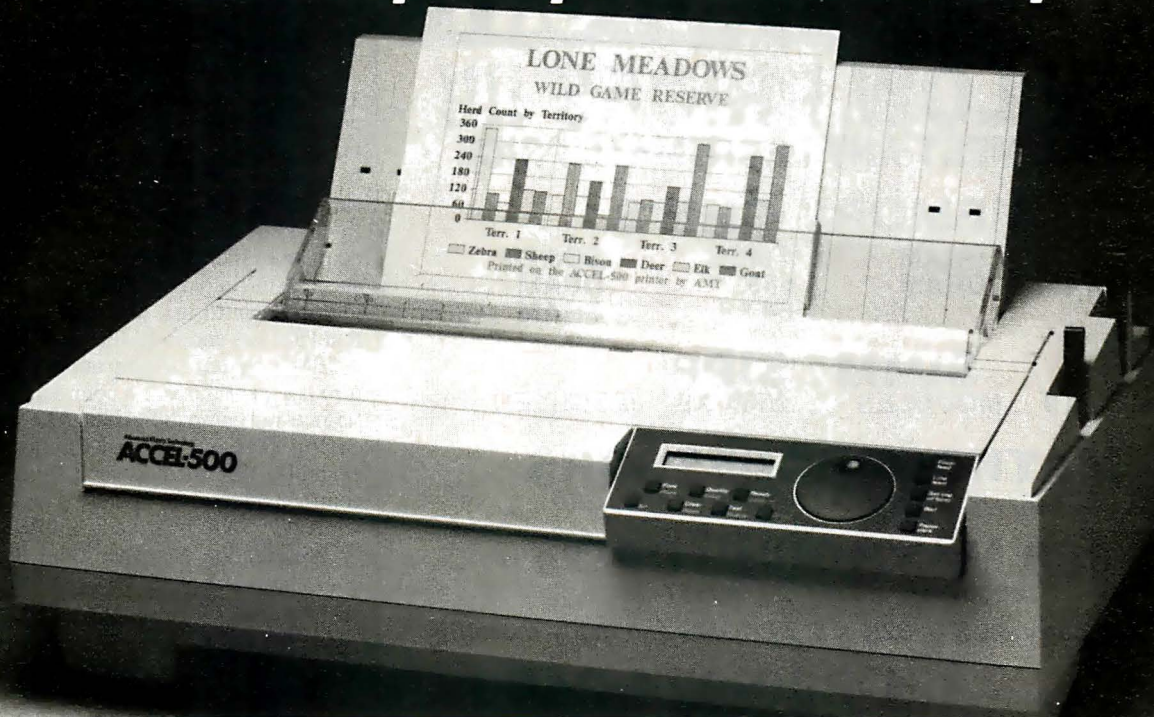

ACCEL-500™ users in large and small companies agree — "...It's the best value printer around!..."

Built tough — built to last

This top performing printer offers you all you need... and more:

- Draft mode (480cps) blazing speed for reviewing draft documents.
- Memo mode (200cps) for internal documents.
- Letter quality (80cps) printing for prestige documents and correspondence.
- Graphics mode — that's right! A rainbow of vibrant colors for presentations, charts, graphs, and even your own direct mail programs.
- Plug-and-run compatibility that plugs right into your Macintosh or PC — virtually any computer or network.
- DEC emulations available.

Toll-free helpline

We're with you all the way. The ACCEL-500 comes with a full 2 year warranty. If you have any questions, pick up the phone and talk to our experts. In addition, we provide on-site service that puts an engineer in your office if you ever have a problem.

Three reasons to order today.

1. Order today and we will ship it to you for a 30 day FREE trial. If you're not delighted, simply ship it back and receive a full refund.
2. Order today and we will throw in a full year of on-site service — value \$215.00 — Free of charge.

Circle 279 on Reader Service Card

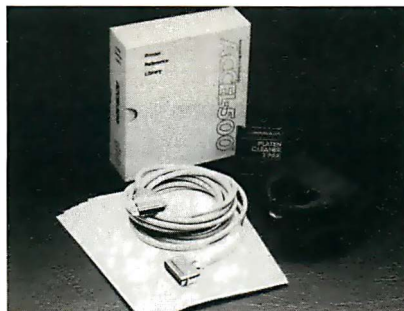

3. Order today and we will include our Quick Start Kit — value \$150.00 — for just \$25.00. You get software, cable, documentation, supplies and more.

The easy to use printer.

Just place your finger into the ACCEL-500's patented SelectDial™ wheel and turn. Different typestyles, speeds, and printing features are right there. And plug-in Intelli-cards™ provide instant software upgrades.

The ACCEL-500 comes with a built-in tractor feed for continuous paper, and will accept optional sheet and envelope feeders. It also comes in a choice of colors: Executive Black and traditional Ivory.

More for your money.

- The ACCEL-500 is priced at just \$1,085.00. With your order you'll receive:
- 16K internal buffer.
 - Six printer emulations.
 - Four fonts.
 - Color and black ribbons.
 - User and programming documentation.
 - Internal diagnostics.

- Special word processing features.
- Graphics capability.
- Store 4 user configurations for quick and easy set-up.
- 17-inch carriage for 'C' size documents.

ORDER TODAY
Toll free
(800) 637-7878

Call us toll free. We will answer all of your questions and take your order for shipment within 24 hours* Use your Visa or MasterCard with NO service charge, or alternatively, give us a purchase order number and we'll ship* Express delivery and quantity discounts available, please ask for details.



Ventura
Peripherals

100 Rancho Road, Suite 27
Thousand Oaks, CA 91362.

*On approved credit and subject to availability.

ACCEL-500, SelectDial and Intelli-card are trademarks of Advanced Matrix Technology, Inc. © 1989 Ventura Peripherals. All rights reserved.

THE CHIP FACTORY

LOW LOW PRICES !!!

WE WILL MEET ANY LEGITIMATE PRICE

MEMORY CHIPS

| | | | |
|------------------|--------------|------------------------|-------------------------|
| 256K 256K X 4 | DRAM DRAM | 1 MEG 64K 64 X 4 | SOJ/ZIP DRAM DRAM |
|------------------|--------------|------------------------|-------------------------|

SIMM / SIPP
1 MEG X 9 MODULES 256K X 9 MODULES

MATHCOPROCESSORS

8087-3, 8087-2, 8087, 80287-8, 80287-10

386 MATHCO's / CPU's

80387-16, 80387-20, 80387-25

We also carry 8K X 8, 32K X 8, EPROMS and many more!!!

For fastest service call **1-800-274-2463**
or **718-803-2352** FAX LINE 1-718-397-0435
77-02 Roosevelt Ave. Jackson Hgts, NY. 11375

POWER TOOL.

Introducing **4x488™**

You get intelligent IEEE-488 and RS232 ports to make instrument programming fast and easy.

You can have up to 4 Mbytes of memory on the same board for your largest programs, RAM disks, and data acquisition tasks.

Compatibility is built-in so you can run your favorite programs or create new ones with our advanced programming tools.

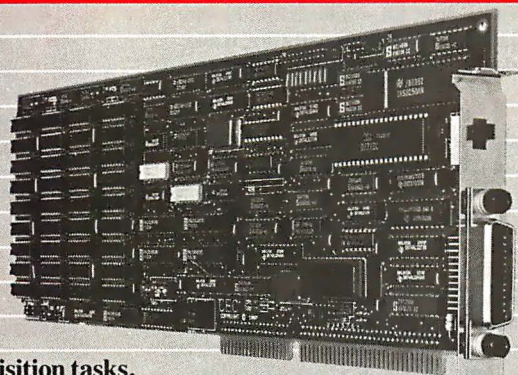

To get your FREE demo disk—call 617-273-1818.
Capital Equipment Corp.
Burlington, MA 01803

The bottom line—IEEE-488, RS232, par. port, 4MB EEM LIM, runs DOS and OS/2.

The Future

The need for compatibility of software and data across systems is clear. The success of WordPerfect, SCO, and others make it obvious. While the current spate of lawsuits as a form of competition will slow this down some, it is bound to continue. One reason it will continue is that companies like WordPerfect Corp. are so successful, in part because they support multiple platforms. Another reason is that IBM has endorsed the idea.

IBM's Systems Application Architecture is a clear move to a common user interface and compatible data. The specification sets out screen designs, for example, that include such things as a common method for operating pull-down windows. SAA is already implemented in Presentation Manager, and applications that work with Presentation Manager are expected to support SAA.

At this point, however, SAA is still mostly in the future. Today's users have to worry about software that is available now, on platforms already in their companies. That's why they will support the use of software that runs everywhere they work, just like Leslie Scott supports a system that runs WordPerfect on both her personal computer and the VAX.

Printer Server Update

In my December 1988 column, I talked about printer servers. These are devices that allow several computers to use the same printer. I aimed the article at two such devices that fit inside the HP LaserJet II, as well as a couple of other products from the same companies. Since then, I have been taken to task by several other manufacturers for leaving their products out of the column.

Some of these products are genuinely interesting, and some have features that could nearly classify them as LANs. Clearly, these machines deserve a look, and they will get one as soon as I can get a few to look at. They were not, however, the topic I intended to look at in my December column, which is why I didn't evaluate them. ■

Wayne Rash Jr. is a consulting editor for BYTE and a member of the professional staff of American Management Systems, Inc. (Arlington, VA). He consults with the federal government on microcomputers and communications. You can contact him on BIX as "waynerash," or in the to.wayne conference.

Your questions and comments are welcome. Write to: Editor, BYTE, One Phoenix Mill Lane, Peterborough, NH 03458.

\$995

Designing In Real-Time Just Got Personal.



There was a time when UNIX-based real-time design meant costly, custom porting. But today, Alcyon makes it easy and affordable for you, the real-time programmer, to get up close and personal with real-time work using Regulus 386.

Take It Personally. Imagine: the advantages of real-time control, Unix compatibility and 386 performance all at your fingertips for under \$1,000. We did, and the result is Regulus 386. It's the first real-time UNIX operating system made to run on any standard 386-based PC AT or PS/2 compatible.

You'll develop programs faster, with less effort, that will be easier to maintain thanks to standard UNIX 5.3 compatibility. And because we made Regulus 386 run on industry-standard architecture, you'll use the same PC for development, testing and run-time execution.

It's multi-tasking, too, so you can divide your real-time program into smaller, more manageable tasks. Plus, Regulus 386 gives you 375-microsecond task switching time, 70-microsecond interrupt response time and the acknowledged best 386 C compiler in the world: MetaWare's High C 386.

Regulus 386 is the finest real-time system money can buy. And now it's affordable, with even bigger discounts in OEM quantities. It makes MS DOS look like a single-tasking proprietary system. It makes proprietary kernels a thing of the past.

And it doesn't require you to develop on one system, debug on another and execute on still another. Regulus 386 has become the programmer's choice, and it's now available for everyone with a real-time challenge.

Free Preview Disc or Technical Support. Now, receive a Regulus 386 preview disc FREE. And there's no obligation. Or, order Regulus 386 now and receive 90 days of free technical support. Turn your 386-based PC into a personal real-time machine. Order Regulus 386 or your free preview disc today. Call 619-587-1155, or return the coupon.

That's an offer you can take personally.

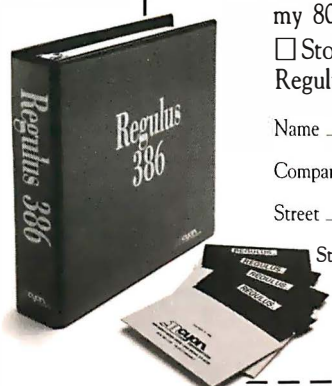

- Yes, I'm interested! Send the FREE Regulus 386 demo disc for my 80386-based industry-standard PC immediately.
- Stop talking, I'm sold! Ship _____ copies of Regulus 386 today at \$995 per copy, and bill me.

Name _____ Title _____
 Company _____ Phone (____) _____
 Street _____ City _____
 State _____ Zip _____ Type of PC _____

Send to: Free Regulus 386 Demo Disc
Alcyon Corporation, 6888 Nancy Ridge Drive
San Diego, CA 92121

ESTABLISHED
1968

MONTGOMERY GRANT

BYTE
5/89

OUTSIDE USACALL
(718)692-0071

For Customer Service
Call Mon-Fri: 9:30am-4:30pm
(718) 692-1148

Relait Outlet: Penn Station, Main Concourse
(Beneath Madison Square Garden) New York City, NY, 10001
Store Hours: Mon-Thurs, 8:30am-8pm/ Fri,8:30am-5:30pm/ Sat,-CLOSED /Sun,9:30am-7
FOR ORDERS & INFORMATION CALL TOLL FREE

1-800-759-6565

OR WRITE TO:
Montgomery-Grant Mail Order
Department, P.O. Box 58,
Brooklyn, N.Y., 11230
FAX NO. 7186923372
TELEX 422-132 MGRANT

ORDER HOURS: Monday-Thursday, 9:00am-7:00pm/Friday, 9:00am-6:30pm/Saturday CLOSED/ Sunday, 9:30am-6:00pm
NO SURCHARGE FOR CREDIT CARD ORDERS / WE INVITE CORPORATE AND EDUCATIONAL CUSTOMERS
CORPORATE LEASING AVAILABLE / DISCOUNTS FOR QUANTITY ORDERS

LAPTOPS

| | |
|--|--------|
| AMSTRAD PPC-640 w/Two Drives & 2400 Baud Modem..... | \$769 |
| TOSHIBA 1600..... | \$3269 |
| TOSHIBA A3100e..... | \$2799 |
| TOSHIBA 1000..... | \$749 |
| TOSHIBA 1200H..... | \$2199 |
| TOSHIBA 1200 HB..... | \$2399 |
| TOSHIBA 3200..... | \$3549 |
| TOSHIBA5100..... | \$4599 |
| NEC MULTISPEED H.D..... | \$1999 |
| NEC ULTRALITE 1MB..... | \$1899 |
| NEC ULTRALITE 2MB..... | \$2299 |
| ZENITH 184 w/TWO FLOPPIES..... | \$1469 |
| ZENITH 184-2 w/20MB..... | \$2199 |
| ZENITH 286 w/20MB..... | \$3099 |
| SPARK EL..... | \$999 |
| COMPAG SLT 286-20..... | \$3899 |
| QUADRAM J.T. FAX | |
| FOR LAPTOPS..... | \$259 |
| MODEMS, EXTERNAL DRIVES & ACCESSORIES AVAILABLE FOR ALL LAPTOPS | |

AMIGA

NEW

| | |
|--|----------|
| AMIGA 500 w/Built-in 5.25" Drive..... | \$529 |
| AMIGA 500 w/1084S Monitor..... | \$799 |
| AMIGA 2000 w/Built-in 3.5" Drive..... | \$1399 |
| AMIGA 2500..... | \$3199 |
| AMIGA 2000 H.D..... | \$1999 |
| AMIGA 1084S RGB MONITOR..... | \$294.95 |
| AMIGA 1010 DISKDRIVE..... | \$189.95 |

ALL AMIGA PERIPHERALS AND
ACCESSORIES IN STOCK!!

PRINTERS

| | |
|--------------------------|--|
| STAR | EPSON |
| NX-1000.....\$169.95 | FX-1050.....\$489.95 |
| NX-1000.....\$169.95 | FX-850.....\$339.95 |
| RAINBOW.....\$219.95 | LO-500.....\$315.95 |
| NX-2400.....\$299.95 | LO-850.....\$529.95 |
| | LO-950.....\$589.95 |
| CITIZEN | LO-1050.....\$729.95 |
| MSP-15E.....\$329.95 | LO-2550.....\$919.95 |
| MSP-40.....\$289.95 | LX-800.....\$189.95 |
| MSP-45.....\$369.95 | |
| MSP-50.....\$349.95 | |
| Tribute-124.....\$389.95 | |
| Tribute-224.....\$589.95 | |
| | PANASONIC |
| | 1080I-II.....\$159.95 |
| | 1092I.....\$299.95 |
| | 1091I-II.....\$189.95 |
| | KXP-1524.....\$499.95 |
| | KXP-1595.....\$409.95 |
| | KXP-1124.....\$319.00 |
| | KXP-1180.....\$189.95 |
| | KXP-1191.....\$249.95 |
| | SANYO PR-3000A DAISY WHEEL.....\$59.95 |

LASER PRINTERS

| | |
|--------------------------------------|--------|
| HP LASERJET SERIES II..... | \$1629 |
| 1 MB EXPANDER..... | \$349 |
| 2MB EXPANDER FOR LASERJET II..... | \$749 |
| HP DESKJET PRINTER..... | \$689 |
| HP LASERJET IID..... | \$2895 |
| SPECIAL! PANASONIC KXP-4450..... | \$1399 |
| BROTHER HL-8E..... | \$1899 |
| NEC LC 860+..... | \$1999 |



EPSON
EPSON EQUITY 1+
IBM XT COMPAT. PKG.
• 640K RAM w/Clock Calendar
• 360K Drive
• Keyboard
• Serial and Parallel Ports
• 12" High Resolution Monitor
• MS DOS / GW Basic

\$799

| | |
|-------------------------------|--------|
| SAME W/20MB HARD DRIVE..... | \$1059 |
| SAME W/30MB HARD DRIVE..... | \$1099 |
| SAME W/40MB HARD DRIVE..... | \$1199 |
| SAME W/TWO 360K FLOPPIES..... | \$879 |

EPSON EQUITY 1e.....CALL!!



EPSON
EPSON EQUITY II+
IBM AT COMPATIBLE
HARD DRIVE PACKAGE
• Keyboard
• 640K RAM
• 80286 Microprocessor
• 1.2MB Floppy Drive
• 20MB Hard Drive
• 12" Monitor
• MS DOS/GW Basic

\$1499

| | |
|-----------------------------|--------|
| SAME W/30MB HARD DRIVE..... | \$1549 |
| SAME W/40MB HARD DRIVE..... | \$1649 |



EPSON
EPSON EQUITY III+
IBM AT COMPATIBLE
20MB HARD DRIVE PKG.
• Keyboard
• 80286 Processor
• 640K RAM
• 6/912 Mhz.
• 1.2MB Floppy Drive
• 20MB Hard Drive
• 12" Monitor
• 8 Expansion Slots
• Serial & Parallel Ports
• MS DOS/GW Basic

\$1799

| | |
|-----------------------------|--------|
| SAME W/30MB HARD DRIVE..... | \$1849 |
| SAME W/40MB HARD DRIVE..... | \$1949 |

WE RECONFIGURE ANY OF OUR COMPUTER PKGS. TO FIT YOUR SPECIFICATIONS.
CALL FOR INFORMATION. WE CARRY MODEMS, DRIVES, CARDS COLOR MONITORS
& ALL OTHER ACCESSORIES FOR YOUR COMPUTER



SHARP PC-7100A PORTABLE
IBM XT COMPATIBLE COMPUTER PKG.
• Detachable Keyboard
• Backlit Screen
• 8 MHz. Turbospeed
• 5.25" Floppy Drive
• 20MB Hard Drive
• Serial/Parallel Ports

\$1288

| | |
|--------------------------------|-------|
| PC 7000A2 w/2 Floppies..... | \$788 |
|--------------------------------|-------|



COMMODORE
COLT
IBM XT COMPATIBLE
PACKAGE
• Keyboard
• Two 360K Floppies
• Serial & Parallel Ports
• 12" Monitor
• MS DOS/GW Basic

\$669



AST
MODEL 80
HARD DRIVE PKG.
• 80286 Processor
• Keyboard
• 1.2MB Floppy Drive
• 20MB Hard Drive
• 12" Monitor
• MS DOS/GW Basic

\$1599

**SEAGATE 20, 30, 40, 60,
80MB HARD DRIVES IN
STOCK!**



NEC
POWERMATE 1
HARD DRIVE PKG.
• 640K
• Keyboard
• 10 MHz.
• 1.2MB Floppy Drive
• 20MB Hard Drive
• Serial/Parallel Ports
• 12" Monitor
• 80286 Processor

\$1499

| | |
|------------------|--------|
| SAME W/30MB..... | \$1549 |
| SAME W/40MB..... | \$1649 |



NEC
POWERMATE 386 SX
• 2MB RAM
• 16 MHz.
• 1.2MB Floppy Drive
• 42MB Hard Drive
• 12" Monitor
• Windows 386
• MS DOS 3.3

\$2799



NEC
POWERMATE 386-20
• 2MB RAM
• 20 MHz.
• 42MB Hard Drive
• 1.2MB Floppy Drive
• 12" Monitor
• Windows 386
• MS DOS 3.3

\$3899



COMMODORE PC10-1
IBM XT COMPAT. PKG.
• 512K RAM
• 360K Floppy Drive
• 12" Monitor
• Serial & Parallel Ports
• Keyboard
• Box of 10 Diskettes

\$499

W/ONE FLOPPY AND 20MB.....\$1029
EGA AND CGA MODELS IN STOCK!!



AMSTRAD PC-1640
• Keyboard
• 640K RAM Turbospeed
• Two 360K Drives
• 12" Monitor
• FREE Mouse & Software
• MS DOS/GW Basic

\$729

W/ONE FLOPPY AND 20MB.....\$1029
EGA AND CGA MODELS IN STOCK!!



COMPAQ
DESKPRO 286
• 640K
• 12MHz.
• 1.2MB Floppy Drive
• 20MB Hard Drive
• 12" Monitor

\$1999

| | |
|--------------------------|--------|
| SAME PACKAGE W/30MB..... | \$2049 |
| SAME PACKAGE W/40MB..... | \$2149 |



COMPAQ 386 S
• 1MB RAM
• 16 MHz.
• 1.2MB Floppy Drive
• 40MB Hard Drive
• VGA Adaptor
• 12" VGA Monitor

\$2999

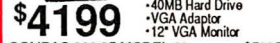

COMPAQ 386-20e
• 1MBRAM
• 20MHz.
• 1.2MB Floppy Drive
• 40MB Hard Drive
• VGA Adaptor
• 12" VGA Monitor

\$4199

| | |
|-----------------------------|--------|
| COMPAQ 386/25 MODEL 60..... | \$5895 |
|-----------------------------|--------|

| | |
|--------------------------------------|-------|
| MAGNAVOX EGA Monitor..... | \$339 |
| MAGNAVOX EGA Monitor w/EGA Card..... | \$459 |
| MAGNAVOX VGA Monitor..... | \$369 |
| MAGNAVOX VGA Monitor w/VGA Card..... | \$569 |
| NEC MULTISYNC II..... | \$579 |



IBM XT
HARD DRIVE PKG.
• IBM XT Computer
• IBM Keyboard
• 256K RAM
• Expandable to 640K
• 360K Disk Drive
• 20MB Hard Drive
• Pkg. of 10 Diskettes (Monitor Optional)

\$1129

IBM XT PACKAGE WITH
TWO FLOPPY DRIVES.....\$899



IBM AT
HARD DRIVE PKG
• 1.2MB Floppy Drive
• 20MB Hard Drive
• Serial/Parallel Ports
• Keyboard
• (Monitor Optional)

\$1599

| | |
|--------------------|--------|
| IBM AT w/30MB..... | \$1649 |
| IBM AT w/40MB..... | \$1749 |

PERSONAL SYSTEM 2

| | |
|--|--------|
| PS/II MODEL 30..... | \$1299 |
| PS/II MODEL 30 w/20MB..... | \$1699 |
| PS/II MODEL 30/286-002..... | \$1549 |
| PS/II MODEL 30/286-021..... | \$1899 |
| PS/II MODEL 50 Z w/30MB..... | \$2749 |
| PS/II MODEL 50-061..... | \$2999 |
| PS/II MODEL 60-071..... | \$3499 |
| PS/II MODEL 70-E61..... | \$3950 |
| PS/II MODEL 70-121..... | \$5299 |
| PS/II MODEL 80-041..... | \$4295 |
| PS/II MODEL 80-071..... | \$4799 |
| 5.25" 360K External Drive for IBM PS/II-30 +PS/11-50..... | \$129 |
| PACIFIC RIM 5.25" 1.2MB External Drive for IBM PS/II 50/60/70/80..... | \$259 |

IBM PERSONAL SYSTEM II MONITORS

| | |
|----------------------|-------|
| 8503 MONOCHROME..... | \$239 |
| 8512 COLOR..... | \$449 |
| 8513 COLOR..... | \$539 |

LEADING EDGE MODEL D,
MODEL D2, MODEL D3-
CALL FOR LOWEST PRICE!



APPLE
APPLE IIC+ w/Floppy
Drive & 12" Monitor
\$599

APPLE IIGS COMPUTER PACKAGE
• Apple IIGS Computer
• 512K Upgrade
• RGB Color Monitor
• Apple 3.5" Disk Drive

\$1499

| | |
|-----------------------------------|--------|
| IMAGewriter II PRINTER..... | \$449 |
| MAC SE COMPUTER W/DUAL DRIVE..... | \$2299 |
| MAC SE COMPUTER W/20MB..... | \$2749 |
| APPLE MAC II..... | \$3499 |
| APPLE MAC II W/40MB..... | \$4299 |
| APPLE MAC II..... | \$1399 |
| APPLE MAC IIX..... | \$4799 |



VENDEX HEADSTART III
• 8-12 MHz.
• 1MB RAM
• 5.25" 1.2MB Floppy
• 3.5" 1.44MB Floppy
• 30MB Hard Drive
• VGA/EGA/CGA/RMDA
Included:
• Serial/Parallel Ports
• Mouse
• MS DOS
• 12" VGA Monitor

\$2599

\$1000
SOFTWARE
INCLUDED



RUSH SERVICE AVAILABLE. CALL FOR DETAILS.

Certified Check, Bank Check, Money Orders, Approved P.O.s, Visa, Mastercard, Am-Ex, Diner's Club, Carte Blanche, & C.O.D.s accepted. No additional surcharge for Credit Card orders. Non-certified checks must wait 4-6 weeks for clearance. N.Y. residents add applicable sales tax. Prices and availability subject to change without notice. Not responsible for typographical errors. Return of defective merchandise must have prior return authorization number or returns will not be accepted. IBM/PC XT are registered trademarks of International Business Machine Corp. Please add 5% shipping & handling. APO/FPO orders please add 10% shipping and handling. All APO/FPO orders are shipped first class priority air. All orders can be shipped Air Express. Call for details. DCA #800233



A PERFECT WORD PROCESSOR AT LAST?

The search for the ideal Mac writing application might be over

I've been looking for the "perfect" word processor for five years now. The search has gone from WordStar, WordPerfect, and Word on the PC to MacWrite, WriteNow, Word, MindWrite, and FullWrite Professional on the Mac with significant detours using the EMACS full-screen editor on DEC-20s and Unix minicomputers. While I've found some very good word processors, I've never encountered one that comes close to my ideals.

I use computers for lots of different purposes. But more than anything else during the day, I use them to write. I write programs. I write memos. I write class schedules. I write grant applications. I write course descriptions. I write E-mail. I write articles and columns—lots of articles and columns.

What I need is a *writer's* word processor. That means I prize editing features above all others, especially those that allow me to customize my editing environment.

On the Sun-3/50 workstation, I stick with GNU EMACS. It's a full-screen editor that's extensible with macros and macro libraries. I can edit programs, E-mail, schedules, and the other items using special editing environments that GNU EMACS allows me to load and save whenever I need them.

Until recently, I had been using Ashton-Tate's FullWrite Professional for my Mac II work. Although FullWrite isn't extensible like GNU EMACS, and it's still too slow (even on an 8-megabyte Mac II), it has a number of highly desirable writer's tools. These include the lifesaving Get Info command, which re-



turns statistics on the length of an article; a good outliner; a dictionary; and a thesaurus. It also works well with the Tempo II and AutoMac III macro makers.

The program has many user-definable preference features (such as auto-saving a document) that help protect writers like me who do their best work at 3:30 in the morning but might forget to save their work. FullWrite also includes a bunch of jazzy desktop publishing features for those times when I actually have to print out something and make it presentable, as opposed to simply sending ASCII text across the electronic void.

But two weeks ago, things changed. I found Nisus.

Full of Features

Users of the QUED and QUED/M program editors will recognize the Nisus word processor immediately. Paragon Concepts, publishers of all three programs, has built Nisus into an unusually complete word processor based on these

two popular program editors.

Like QUED and QUED/M, Nisus is fully extensible and comes with a complete macro programming capability similar to GNU EMACS. It includes many functions for managing text files. Nisus rounds out the feature list with some elegant writer's tools: a thesaurus, a dictionary, comparison operations, index and table-of-contents generators, line numbering, unlimited Undos, 10 Clipboards, and a Get Info command even more complete than FullWrite's.

Like FullWrite, it follows the practice of keeping the complete Font, Size, and Style menus on the menu bar where they belong, and not hidden in other menus like Word 3.02 does.

Besides its text and document management power, Nisus includes a bunch of desktop publishing and graphics design features that position it squarely in competition with FullWrite and Microsoft Word 4.0. This means I can use Nisus for

continued

my regular text work and still print off snazzy-looking reports and memos without having to switch back to FullWrite. Since I don't do much desktop publishing, but I do a lot of writing and editing, I set out to test Nisus from the perspective of a writer and editor.

The first glaring omission in Nisus is the lack of a good outliner, like you have in FullWrite or MindWrite. At least Paragon didn't bother grafting on a lousy outliner like the one in Word 3.02. So far, I've made up for this missing organizational aid by using Symmetry's Acta desk accessory outliner, but I really need Paragon to incorporate an outliner in its next release. The other missing piece is footnote/end note capability. Nisus can do neither, making it unusable as a scholar's word processor. These missing pieces keep Nisus from being the best writer's word processor currently available for the Macintosh.

Other than the missing outliner, I could find no real faults with Nisus in two weeks of constant use. One bit of strange behavior: The displayed text occasionally blanks out (except the line you are typing), usually when the screen is scrolling rapidly. This funky screen behavior doesn't lose any text, but it's something the Paragon folks should take a look at.

But let's get back to the good stuff. Nisus includes an auto-saving feature that allows you to auto-save a file to two different disk volumes: handy if you are especially paranoid about losing text. Nisus also saves a backup file in the same directory called `filename.bak` that includes the current text in the file buffer. Since Nisus is a memory-based word processor, these special file-to-disk saving strategies are particularly welcome and help prevent text losses. Unlike FullWrite's text auto-saving, you don't lose any text if you continue to type during Nisus's auto-save cycle. If you did that with FullWrite, you could lose several words, depending on the speed of your disk and how fast you type. Since I tend to type in bursts, FullWrite's auto-save behavior is a big nuisance that Nisus seems to have resolved.

Professional Tools

One of the slickest and most informative aspects of Nisus are its rulers. Besides giving you the usual information about the margins, tabs, line spacing, paragraph spacing, line justification, and the like, these rulers include an info bar that tells you which line you're on in a page (or document) and how many characters you've typed in a particular paragraph.

ITEMS DISCUSSED

Nisus version 1.0\$395
Paragon Concepts, Inc.
990 Highland Dr., Suite 312
Solana Beach, CA 92075
(619) 481-1477
Inquiry 1101.

FullWrite Professional\$395
Ashton-Tate Corp.
20101 Hamilton Ave.
Torrance, CA 90502
(213) 329-8000
Inquiry 1102.

You can also bring up Nisus's graphics and drawing tools into an expanded ruler (called a graphics ruler) by toggling a graphics button that adjoins the ruler and sits on top of the vertical scroll bar. Another button toggles the text ruler functions, while a third pops up a partially editable page-preview display that lets you alter the number of columns, among other desktop publishing tricks.

The real power of Nisus, though, is its programmability. With a little practice and some patience, you can create a text-editing environment that rivals that of EMACS in many respects and exceeds it in others.

The heart of Nisus's programmability is its macros. The application comes with over a hundred macros that you can access immediately from the Tools menu. These range from simple font-change macros (e.g., changing bold to italic) to the sophisticated extraction of references from a document.

There's also a selection that converts QUED/M macros to run under Nisus. All supplied macros can be viewed and edited directly in Nisus, which makes it easy to see how the macro language is implemented. The macro language and Nisus both support variables. Text variables can be used to mark specific dates, times, document names, page numbers, or cross-reference listings.

The Nisus macro language lacks some of the programming features of a generalized language, however. It does not include any direct conditional structures similar to the `IF...THEN...ELSE` statements, nor does it permit looping. Most of the omissions in the macro language need not hamper the creation of sophisticated macros, though, since Nisus includes an extensive implementation of the Unix `grep` (for global regular expression parser) utility. This utility supports more kinds of pattern matching than you may have thought possible and

includes metacharacters, literal text, wild-card text, and multiple string patterns. Nisus also supports recursive macro calls, so the lack of iterative control structures is not a big problem.

Besides writing and editing Nisus macros directly, you can also record them, which makes the Nisus macro facility easy for novices to use. The macro recorder captures commands (including other macros), keystrokes, or mouse-clicks to be executed. With Nisus's macro recorder, you would select text in a macro by using built-in keyboard commands, rather than mouse click-and-drag. All macros that are recorded or typed can be used from the Tools menu just like any Nisus command. You can modify any macro using the macro editor regardless of how it was created.

By Comparison

Nisus can compare any two files automatically, and rather painlessly. If (like me) you generate two drafts of a document, put them aside for a few days, and then come back to them to finish the job, an automatic file-comparison procedure is a gift from the heavens. No matter how clever I am at naming files, I always end up forgetting which file contains what information and in what state. Nisus pops up the two files side-by-side and compares them on-line for you in real time, pointing out where they differ. You can even tell Nisus to ignore blank spaces.

Sometimes it's handy to have two different files on-screen at the same time, especially if one is a notes file you refer to while writing. Nisus lets you scroll them synchronously, so you're always as far into one as you are into the other.

One of the things I always count on EMACS catching for me are orphan parentheses and quotation marks. Until Nisus, I couldn't expect the Mac to do the same for me. Nisus keeps track of all parentheses and quotation marks and alerts you to missing ones.

After I've used this program for several months, I'll be back with an updated report on how it's fared as my main Mac word processor. If its first two weeks are any indication, Nisus may end my search for the perfect word processor. ■

Don Crabb is the director of laboratories and a senior lecturer for the computer science department at the University of Chicago. He can be reached on BIX as "decrabb."

Your questions and comments are welcome. Write to: Editor, BYTE, One Phoenix Mill Lane, Peterborough, NH 03458.

1024X768 IBM COMPATIBLE VGA VIDEO CARD

VGA W O N D E R™

T H E S E C O N D W O N D E R

1024X768

Plus: VGA, EGA, CGA, MDA & Hercules
on Standard MULTISYNC monitors

Yes! the Phenomenal VGAWONDER does it all at IBM Hardware level compatibility with automatic monitor detect and no dip switches or jumpers to set. A HOT CARD for the 286/386 POWER USER with AUTO BUS DETECT for 8 or 16 bit slots, running with a 16 bit datapath with 1:1 interleave. 100% IBM HARDWARE LEVEL COMPATIBILITY means that ALL software and operating systems designed for IBM systems will run. 1024 WILL BE DISPLAYED IN COLOR ON STANDARD MULTI-FREQUENCY MONITORS. Although these features are expected from ATI they are NOT AVAILABLE from other manufacturers. EGA on all monitors including RGB & TTL means a perfect card for networks. MOUSE ON BOARD! ATI built the mouse right in to this one, why not? No extra charge! VGAWONDER is available in both 512K and 256K Versions. Ask your dealer for more information.



TECHNOLOGIES INC.

Technology you can Trust.

ATI Technologies Inc.
3761 Victoria Park Ave., Scarborough, Ontario
Canada M1W 3S2 Telex: 06-966640 (ATI TOR)
Tel: (416) 756-0718 Fax: (416) 756-0720



Circle 27 on Reader Service Card

ATI, VGA W O N D E R — ATI Technologies Inc.; Multisync — NEC Home Electronics Inc.;
AUTOCAD — Autodesk Inc.; WINDOWS — Microsoft Inc.; GEM — Digital Research Inc.;
VENTURA — Xerox Corp.; HERCULES — Hercules Computer Technology Inc.;
IBM, VGA, EGA, CGA — International Business Machines Corp.

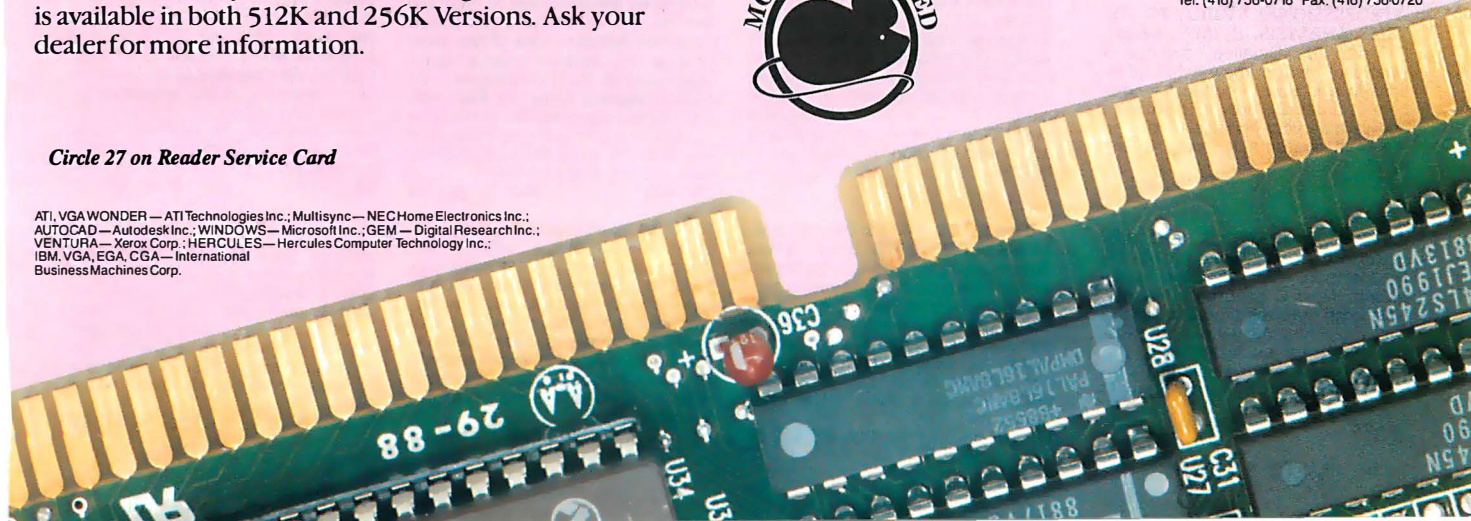

Take any 3 books for only \$1⁰⁰ each

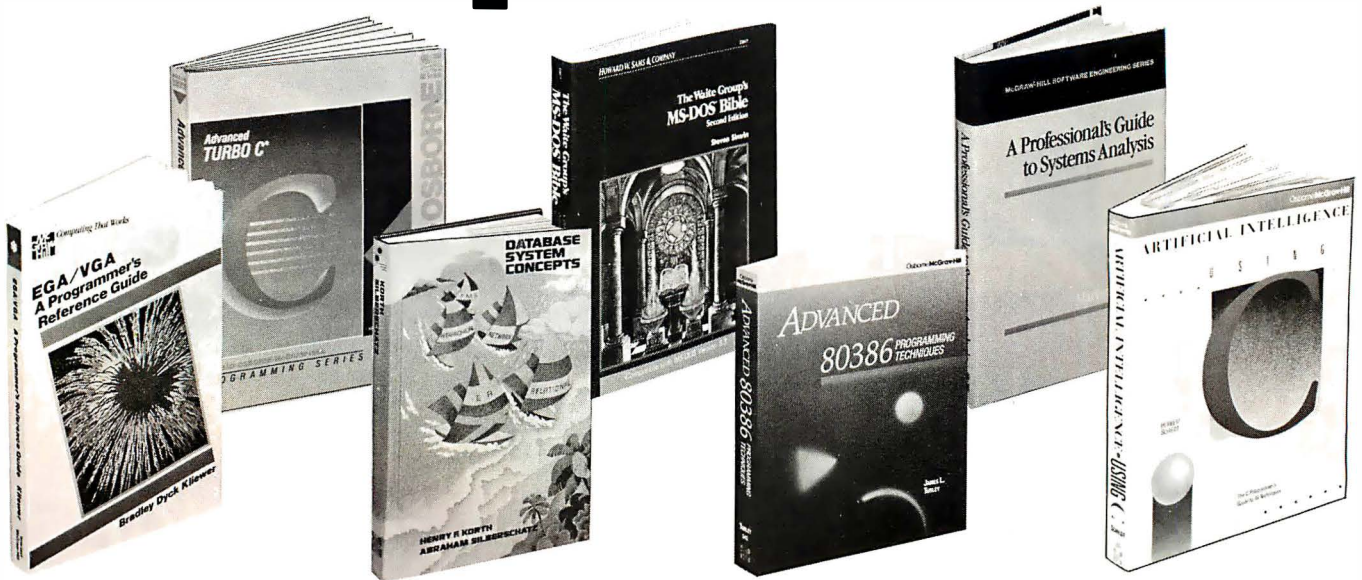

when you join BYTE Book Club[®] VALUES UP TO \$139.50

- Your one source for computer books from over 100 different publishers
- the latest and best information in your field
- discounts of up to 40% off publishers' list prices

OS/2 PROGRAMMER'S GUIDE. By E. Iacobucci. 1100 pp., illus. softbound. "Byte" magazine called it "a necessity." This giant reference explains all the basic functions you'll need, with emphasis on such new or different functions as multitasking and memory management.
881300-X Pub. Pr., \$29.95

UNIX UTILITIES. By R.S. Tare. 352 pp., illus., softbound. This practical manual shows how to make the best use of UNIX utilities. It covers more utilities than any other book of its kind and provides numerous examples of real applications.
628/84X Pub. Pr., \$27.95

dBASE POWER: Building and Using Programming Tools. By P.L. Olympia, R. R. Freeland, and R. Wallin. 380 pp., illus., softbound. This practical guide shows the experienced dBASE III or dBASE III PLUS programmer how to use to the fullest such features as RUN and CALL/LOAD, as well as how to write C and assembly language programs that perform dBASE functions for you.
584696-9 Pub. Pr., \$29.95

A PROFESSIONAL'S GUIDE TO SYSTEMS ANALYSIS. By M.E. Modell. 307 pp., illus. Detailed coverage of what you need to know—what questions to ask, how to conduct a cost-benefit analysis, how to document and validate your findings—to design the best systems for your user's needs.
426/325 Pub. Pr., \$34.95

ADVANCED GRAPHICS IN C: Programming and Techniques. By N. Johnson. 430 pp., illus., softbound. Now C programmers can write crisp graphics programs for the IBM-PC using the IBM EGA (Enhanced Graphics Adaptor) or the AT&T Image Capture Board (ICB). Includes GRAPHIQ, a complete C graphics toolkit.
881257-7 Pub. Pr., \$22.95

A COMPREHENSIVE GUIDE TO AI AND EXPERT SYSTEMS: Turbo Pascal Edition. By R.I. Levine, D.E. Drang, and B. Edelson. 256 pp., 99 illus. A must for everyone who wants to understand and utilize artificial intelligence for commercial, military, scientific, or educational applications. It's all in clear, simple language with many illustrations and sample programs.
374/708 Pub. Pr., \$24.95

ADVANCED TURBO C.[®] By H. Schildt. 397 pp., illus., softbound. Complete Turbo C mastery can be yours—from stacks, queues, linked lists and binary trees, to operating system interfacing, porting, debugging, and much more. Fully explains how to get the most from the power and speed of Turbo C.
881280-1 Pub. Pr., \$22.95

ADVANCED 80386 PROGRAMMING TECHNIQUES. By J.L. Turley. 509 pp., illus., softbound. Offering advanced techniques for serious programmers, this hands-on guide covers advanced memory segmentation, the internal four-level protection hierarchy, multitasking, demand paging, system security, 8086/80186/80286 emulation, and intertask communication.
881342-5 Pub. Pr., \$22.95

THE WAITE GROUP'S MS-DOS BIBLE, Second Ed. By S. Simrin. 522 pp., illus., softbound. Shows you how to start up your system, create and manage files, customize your keyboard, and become proficient in such advanced MS-DOS features as LINK, DEBUG, TSR programming and device drivers.
584702-7 Pub. Pr., \$22.95

EGA/VGA: A Programmer's Reference Guide. By B.D. Kiewer. 269 pp., illus., softbound. All the practical guidelines are right here for learning the ins and outs of the Enhanced Graphics Adaptor—one of the most popular PC add-on boards available—and its PS/2 counterpart, the Video Graphics Array. It's filled with innovative programming techniques . . . tips for working around the bugs in the BIOS . . . and EGA/VGA BIOS calls not available elsewhere.
350/892 Pub. Pr., \$29.95

DATABASE SYSTEM CONCEPTS. By H. F. Korth and A. Silberschatz. 546 pp., illus. From fundamental concepts to advanced problem solving, this book provides a clear understanding of the design and use of database systems. Also demonstrates the best ways to protect data from unauthorized access and malicious or accidental alteration or destruction.
447/527 Pub. Pr., \$44.95

ARTIFICIAL INTELLIGENCE USING C: The C Programmer's Guide to AI Techniques. By H. Schildt. 412 pp., 37 illus., softbound. This hands-on guide shows you how to create your own AI applications and systems using C. After an introductory overview it provides coverage of expert systems, logic, natural language processing, machine learning, pattern recognition, and more, with ready-to-run programs illustrating each topic.
881255-0 Pub. Pr., \$21.95

PROGRAMMING USING THE C LANGUAGE. By R.C. Hutchison and S.B. Just. 519 pp., illus. Whether you want to understand programs in C written by others, or write better C programs of your own, this practical, authoritative book gives you the tools and guidance you need. Coverage includes program organization, sorting algorithms, recursion, linked lists, and more — with many sample programs.
315/418 Pub. Pr., \$29.95

HARD DISK MANAGEMENT with MS-DOS and PC-DOS. By D. Gookin and A. Townsend. 307 pp., illus. Shows you how to make the best use of your hard disk for all types of programs, with an emphasis on organization, data security, and enhancing performance. Easy enough for novices, yet sophisticated enough for power users, it's packed with helpful hints, proven shortcuts, and clear explanations.
583954-7 Pub. Pr., \$27.95

TRICKS OF THE UNIX MASTERS. By R.G. Sage. pp. illus. Many of UNIX's most interesting features have virtually been kept secret from users — until now! This master guide goes beyond the basics to show you the shortcuts, tools, tips, and tricks it could take years to discover on your own.
584637-3 Pub. Pr., \$22.95

BYTE BOOK CLUB®

Membership Order Card

Please enroll me as a member and send me the three choices I have listed below. Bill me only \$3.00, plus local tax, postage and handling. I agree to purchase a minimum of two additional books during my first year as outlined under the Club plan described in this ad. Membership in the club is cancellable by me any time after the two book purchase requirement has been fulfilled. A shipping and handling charge is added to all shipments.

Indicate below by number the books you want. A few expensive books (noted in the descriptions) count as more than one choice.

| | | |
|----------------------|----------------------|----------------------|
| <input type="text"/> | <input type="text"/> | <input type="text"/> |
|----------------------|----------------------|----------------------|

Signature _____

Name _____

Address/Apt.# _____

City, State, Zip _____

Corporate Affiliation _____

This order subject to acceptance by McGraw-Hill. All prices subject to change without notice. Offer good only to new members. Foreign member acceptance subject to special conditions.

BYTE BOOK CLUB®

Membership Order Card

Please enroll me as a member and send me the three choices I have listed below. Bill me only \$3.00, plus local tax, postage and handling. I agree to purchase a minimum of two additional books during my first year as outlined under the Club plan described in this ad. Membership in the club is cancellable by me any time after the two book purchase requirement has been fulfilled. A shipping and handling charge is added to all shipments.

Indicate below by number the books you want. A few expensive books (noted in the descriptions) count as more than one choice.

| | | |
|----------------------|----------------------|----------------------|
| <input type="text"/> | <input type="text"/> | <input type="text"/> |
|----------------------|----------------------|----------------------|

Signature _____

Name _____

Address/Apt.# _____

City, State, Zip _____

Corporate Affiliation _____

This order subject to acceptance by McGraw-Hill. All prices subject to change without notice. Offer good only to new members. Foreign member acceptance subject to special conditions.

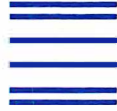

NO POSTAGE
NECESSARY
IF MAILED
IN THE
UNITED STATES

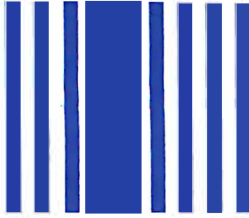

BUSINESS REPLY MAIL

FIRST CLASS MAIL PERMIT NO. 42 HIGHTSTOWN, NJ

POSTAGE WILL BE PAID BY ADDRESSEE

McGraw-Hill Book Clubs
P.O. Box 582
Hightstown, NJ 08520-9959



NO POSTAGE
NECESSARY
IF MAILED
IN THE
UNITED STATES

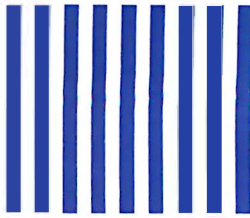

BUSINESS REPLY MAIL

FIRST CLASS MAIL PERMIT NO. 42 HIGHTSTOWN, NJ

POSTAGE WILL BE PAID BY ADDRESSEE

McGraw-Hill Book Clubs
P.O. Box 582
Hightstown, NJ 08520-9959



SADT: Structured Analysis and Design Technique. By D. Marca and C. McGowan.
402/353 Pub. Pr., \$49.95
(Counts as 2 of your 3 books)

PROGRAMMING WITH TURBO PASCAL. By D. Carroll.
852908-5 Pub. Pr., \$39.95

HIGH-SPEED ANIMATION & SIMULATION FOR MICROCOMPUTERS. By L. Adams.
583855-9 Pub. Pr., \$20.95

PROGRAM TRANSLATION FUNDAMENTALS: Methods and Issues. By P. Calingaert.
584589-X Pub. Pr., \$36.95

HOW TO BE A SUCCESSFUL COMPUTER CONSULTANT. By A. R. Simon.
572/968 Pub. Pr., \$24.95

UNDERSTANDING & USING dBASE III® PLUS. By R. Krumm.
583940-7 Pub. Pr., \$22.95

32-BIT MICROPROCESSORS. Edited by H. J. Mitchell.
425/85X Pub. Pr., \$48.50

8086/8088/80286 ASSEMBLY LANGUAGE, Revised & Expanded. By L.J. Scanlon.
584839-2 Pub. Pr., \$21.95

NETWORKING SOFTWARE. By C. B. Ungaro.
606969-9 Pub. Pr., \$39.95

THE DATABASE EXPERT'S GUIDE TO SQL. By F. Lusardi.
390/061 Pub. Pr., \$39.95

PRINCIPLES OF ARTIFICIAL INTELLIGENCE AND EXPERT SYSTEMS DEVELOPMENT. By D.W. Rolston.
536/147 Pub. Pr., \$44.95

APPLYING TURBO PASCAL LIBRARY UNITS. By N. Shammass.
584791-4 Pub. Pr., \$22.95

DATA STRUCTURES USING PASCAL, 2nd Ed. By A. M. Tenenbaum & M. J. Augenstein.
583738-2 Pub. Pr., \$46.00

MICROCOMPUTER LANS: Network Design and Implementation. By M.F. Hordeski.
584580-6 Pub. Pr., \$28.95

OPERATING SYSTEMS. By M. Milenkovic.
419/205 Pub. Pr., \$42.95

IBM® PS/2® TECHNICAL GUIDE. By C.M. Halliday & J.A. Shields.
584831-7 Pub. Pr., \$24.95

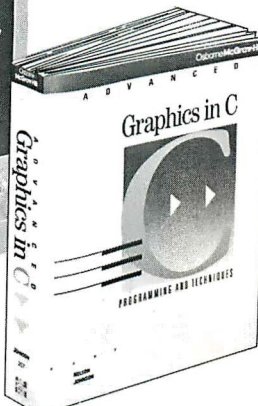
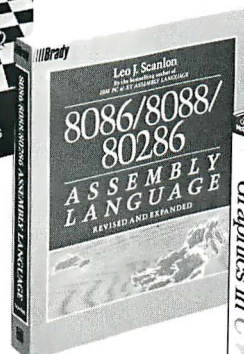
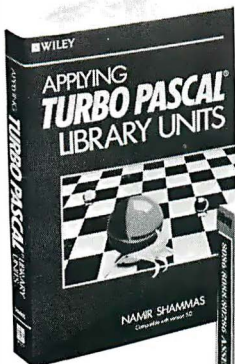

Any 3 books for \$1.00 each... if you join now and agree to purchase two more books—at handsome discounts—during your first year of membership.

MASTERING TURBO PASCAL 4.0, 2nd Ed. By T. Swan.
584762-0 Pub. Pr., \$22.95

DESIGNING USER INTERFACES FOR SOFTWARE. By J.S. Dumas.
584641-1 Pub. Pr., \$31.00

68000 ASSEMBLY LANGUAGE PROGRAMMING, 2nd Ed. By L. Leventhal; D. Hawkins; G. Kane & W. Cramer.
583817-6 Pub. Pr., \$28.95

C CHEST AND OTHER C TREASURES FROM DR. DOBB'S JOURNAL. Edited by A. Holub.
584807-4 Pub. Pr., \$24.95

HARD DISK MANAGEMENT IN THE PC & MS-DOS ENVIRONMENT. By T. Sheldon.
565/562 Pub. Pr., \$24.95

FILE ORGANIZATION FOR DATABASE DESIGN. By G. Wiederhold.
701/334 Pub. Pr., \$42.95

USING TURBO C. By H. Schildt.
881279-8 Pub. Pr., \$19.95

123: THE COMPLETE REFERENCE. By M. Campbell.
881005-1 Pub. Pr., \$22.95

PROGRAMMING IN C, Revised Ed. By S.G. Kochan.
584701-9 Pub. Pr., \$24.95

QUICK C PROGRAMMING FOR THE IBM. By C. Townsend.
584659-4 Pub. Pr., \$22.95

STRUCTURED PROGRAMMING IN ASSEMBLY LANGUAGE FOR THE IBM PC. By W. C. Runnion.
584827-9 Pub. Pr., \$43.25

TELECOMMUNICATIONS AND DATA COMMUNICATIONS FACTBOOK. By J. Abbatiello and R. Sarch.
606965-6 Pub. Pr., \$44.95

DATA TYPES AND DATA STRUCTURES. By J. J. Martin.
583689-0 Pub. Pr., \$45.00

WORDPERFECT®: THE COMPLETE REFERENCE. By K. Acerson.
881312-3 Pub. Pr., \$27.95

TROUBLESHOOTING AND REPAIRING THE NEW PERSONAL COMPUTERS. By A. Margolis.
583871-0 Pub. Pr., \$18.95

New! BYTE LARGE SYSTEMS Books

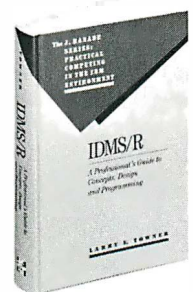

IDMS/R: A Professional's Guide to Concepts, Design and Programming. By L.E. Towner. 420 pp., illus. Tap the full potential of the Integrated Data Management System with this comprehensive guidebook. In three sections the book covers logical database design, physical database design, and database access and maintenance in a practical tutorial manner.
650/87X Pub. Pr., \$39.95

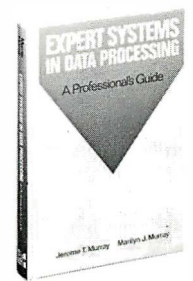

EXPERT SYSTEMS IN DATA PROCESSING: A Professional's Guide. By J.T. Murray and M.J. Murray. 237 pp., illus. Shows you how to successfully implement expert systems in a mainframe environment. From planning through implementation, it covers all the fundamentals... available shells and languages... frame-based system design... the IBM Expert System Environment... and sources for everything you'll need.
440/883 Pub. Pr., \$34.95

Here's how BYTE Book Club® works to serve you:

- **Important information . . . we make it easy to get!** Today, professionals who perform best are those who are best informed. For reliable, hands-on information, turn to the Byte Book Club. Every 3 or 4 weeks (12-15 times a year), members receive the Club Bulletin offering more than 30 books — the best, newest, most important books from all publishers.
- **Dependable service . . . we're here to help!** Whether you want information about a book or have a question about your membership, just call us toll-free or drop us a line. To get only the books you want, make your choice on the Reply Card and return it by the date specified. If you want the Main Selection, do nothing — it will be sent to you automatically. (A small shipping and handling charge is added to each shipment.)
- **Club convenience . . . we do the work!** You get a wide choice of books that

simply cannot be matched by any bookstore. And all your books are conveniently delivered right to your door. You also get 10 full days to decide whether you want the Main Selection. (If the Club Bulletin ever comes late and you receive a Main Selection you don't want, return it for credit at our expense.)

- **Substantial savings . . . and a bonus program too!** You enjoy substantial discounts—up to 40%—on every book you buy. Plus, you're automatically eligible for our Bonus Book Plan which allows you savings up to 70% on a wide selection of books.
- **Easy membership terms . . . it's worthwhile to belong!** Your only obligation is to purchase 2 more books — at handsome discounts — during the next 12 months, after which you enjoy the benefits of membership with no further obligation. You or the Club may cancel membership anytime thereafter.

Fill out the card and mail today! If the card is missing, write to:
BYTE Book Club®, P.O. Box 582, Hightstown, New Jersey 08520-9959
For faster service in enrolling, call 1-800-2-MCGRAW

OS/2 and Presentation Manager...

When You Need Reliable Information, Go to the Source.

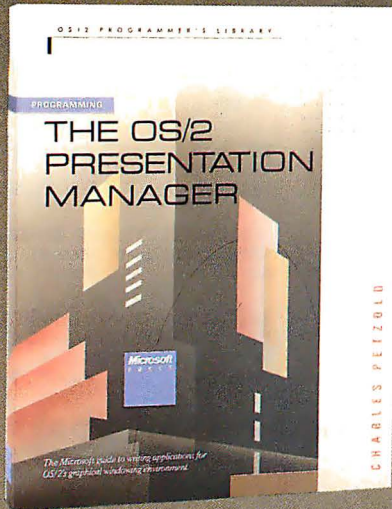

PROGRAMMING THE OS/2 PRESENTATION MANAGER

Charles Petzold

Here is the first full discussion of the features and operation of the OS/2 1.1 Presentation Manager. If you're developing OS/2 applications, this book will guide you through Presentation Manager's network of windows, messages, and function calls. Petzold includes scores of valuable C programs and utilities. Endorsed by the Microsoft Systems Software group, this book is unparalleled for its clarity, detail, and comprehensiveness. Petzold covers: managing windows ■ handling input and output ■ controlling child windows ■ using bitmaps, icons, pointers, and strings ■ accessing the menu and keyboard accelerators ■ working with dialog boxes ■ understanding dynamic linking ■ and more. An incomparable resource. **\$29.95**

Order Code 86-96791

ADVANCED OS/2 PROGRAMMING

Ray Duncan

Authoritative information, expert advice, and great examples in assembly language and C make this comprehensive overview of OS/2 indispensable to anyone programming the OS/2 kernel. Duncan addresses a broad range of significant OS/2 issues: programming the user interface; mass storage; memory management; multitasking; interprocess communications; customizing filters, device drivers, and monitors; and using OS/2 dynamic link libraries. A valuable reference section includes detailed information on each of the more than 250 system service calls in version 1.1 of the OS/2 kernel. **\$24.95**

Order Code 86-96106

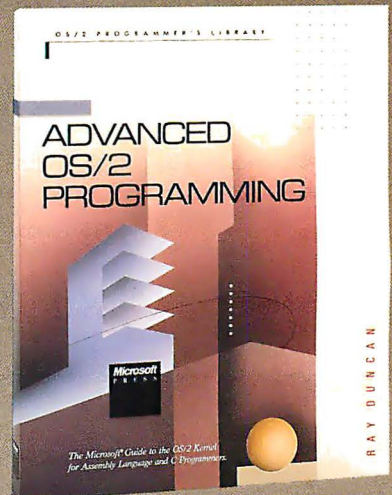

Microsoft® Press

Hardcore Computer Books

Circle 178 on Reader Service Card

Available wherever books and software are sold.

Or place your credit card order by calling **1-800-638-3030** (8AM to 4PM EST). In MD call 824-7300.



SETTING UP OS/2

Hints and tips to make the installation of OS/2 as painless as possible

Now that I've shown you how to assemble an inexpensive OS/2-ready workstation, I'll show you how to install OS/2 on that workstation. While I'm at it, I'll also describe how to install DOS and convince the two to coexist peacefully. (I'm assuming that you, like most of the world, also use either MS-DOS or PC-DOS and wish to continue using it.)

Before you get started, however, a word of caution: The OS/2 installation itself is simple, but it will remove DOS from your disk. Therefore, before you do anything else, ensure that you have a bootable DOS floppy disk around. I'll fix the DOS problem later with an inexpensive utility, but keep the floppy disk handy for now—you may need to get to DOS.

Why? The first reason that comes to mind is easy access to a text editor. Until you get comfortable with one of the OS/2 editors, you'll need your current one to modify CONFIG.SYS files and the like, and your current editor probably needs DOS to run. Remember, the days of the three-line CONFIG.SYS file are over—a minimum reasonable CONFIG.SYS file is more than a screen's worth of text, so you'll need an editor to handle CONFIG.SYS changes.

You can, of course, use your DOS editor in the compatibility box—oops, IBM doesn't call it the compatibility box anymore, it's now called the DOS mode session. But if you mess with the CONFIG.SYS file to the point where OS/2 won't boot, you'll have to do some surgery on the CONFIG.SYS file from a booted floppy disk. As OS/2 is too large

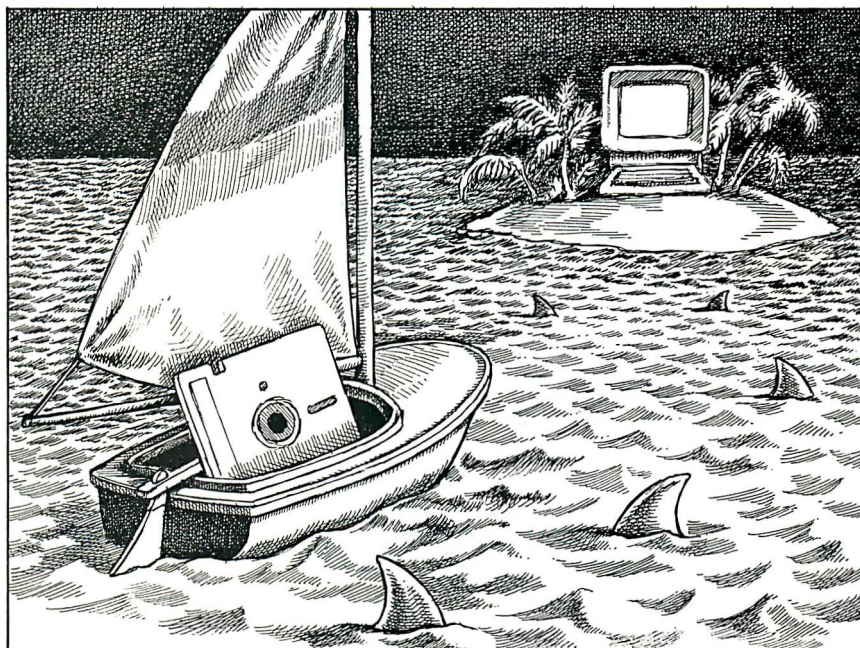

to boot from a floppy disk, any editor started from a floppy disk *must* be a DOS program.

Also, be sure that you have 8 megabytes or more of free space on your hard disk, or you won't be able to install OS/2.

Next, back up the disks that OS/2 arrived with using DISKCOPY. When you copy the disks, first write-protect them. I stress this because I was reminded of this advice the hard way—I tried to boot OS/2 on a defective 1.44-megabyte floppy disk drive. The drive trashed the disk.

The (ahem) *original* disk.

I know that this is old advice, but please heed it—here at the Moulton, Minasi & Company Charles Babbage Memorial Computation Center, we've ended up with two bad 1.44-megabyte drives out of five: two bad Mitsubishis and three good TEACs. And I hear unconfirmed rumors that PS/2 1.44-megabyte drives are more problem-prone than the average drive.

However, if you decide to write-pro-

tect the backups, be sure not to protect the backup of the disk labeled Installation Disk. OS/2 writes some kind of log file to that disk while installing and won't install if it finds the disk write-protected.

You start installing OS/2 by inserting the Installation Disk into drive A and then rebooting. Your first indications of whether the process is working or not are the usual copyright notices and a five-digit *build number*. My build number is 88300 on regulation IBM OS/2 1.1. If you have IBM OS/2, you'll probably see the same number.

Don't worry about the amount of time required to boot OS/2. From the time that the disk starts to grind to the time it asks you some questions will be about 2 minutes. Remember, this program is loading into *megabytes* of space, so it will take some time.

After you see the opening screens showing *IBM* in 5-inch-high letters and

continued

some basic instructions, you'll see a screen asking you whether or not to format the disk. If you have a disk larger than 32 megabytes and you intend to use both DOS and OS/2 on your machine, I'd recommend that you *not* allow the small installation program called the Installation Aid to format the disk. The reason is simple: To accommodate disks larger than 32 megabytes, OS/2 1.1 and DOS 4.x use a disk ID, or boot record, whose format is different from previous DOS

ITEM DISCUSSED

MultiBoot \$49.95
 Bolt Systems, Inc.
 4340 East-West Hwy.
 Bethesda, MD 20814
 (301) 656-7133
Inquiry 1024.

boot-record formats. That boot record looks like a bad disk to DOS 3.3.

Under DOS 3.3, as many of you know, a disk larger than 32 megabytes is addressed by using FDISK to "fool" DOS. You can use FDISK to partition a single physical disk into multiple *logical drives*, all 32 megabytes or smaller. Recall that FDISK under DOS 3.3 cannot create a partition larger than 32 megabytes. However, FDISK under DOS 4.0 and OS/2 1.1 *can* create larger partitions.

If you let OS/2 format your disk into a single logical drive larger than 32 megabytes, the only version of DOS that will be able to recognize these drives is DOS 4.x. So be sure to leave your options open—format the disk with DOS 3.3, use FDISK and FORMAT to create multiple logical drives, and *then* turn OS/2 loose.

Unpacking Takes Time

By now, the Installation Disk has loaded itself, as well as a minimal version of OS/2, onto the hard disk. This minimal OS/2 can't do anything yet except boot the Installation Aid. Reboot the system, and the Installation Aid will appear. It instructs you to insert, in turn, disks 1 through 4 in the drive and wait.

A word of advice—make sure you have something else to do, because it will take up to 10 minutes to read each disk. That's because the files on these disks are what IBM calls *packed* files—files shrunk with a compression algorithm of some kind. Bulletin board junkies in the audience will recognize the same idea in the form of files with the extension .ARC. Such files have been compressed to reduce transmission times. I suspect IBM compressed the OS/2 files to save on disk costs (1.44-megabyte floppy disks are, after all, still expensive) and so as to not shock people by presenting them with 10 1.44-megabyte floppy disks when they tried to install OS/2.

The files are uncompressed with the UNPACK.EXE utility provided with OS/2 1.1. IBM has a new file-naming convention—files whose names end with @ are compressed files. UNPACK.EXE looks for these files. (In case you're wondering, no Pack program is provided with OS/2.)

About 30 minutes later, you'll see a message telling you that everything is done, and you need only reboot to start OS/2. Reboot, and you'll see the initial Presentation Manager screen. The prominent feature of the screen is a window called Start a Program. By the way, if you look closely, you'll notice that something is a little strange about the text on the screen—PM uses proportionally spaced fonts. No kerning yet.

continued

GRASP is clearly the hands-down winner in terms of sheer power, flexibility, and speed.
 —PC Magazine

Program in the 4th Dimension... ANIMATE!

Get unlimited action and interaction with the most powerful PC animation system available, by calling Grasp routines from your programs in C, Pascal, Basic, and other languages.

Or develop your graphics applications directly in Grasp! Take advantage of:

- 74 animation & effects commands
- 25 predefined fades
- single-command animation
- all major graphics modes
- screen capture and graphics printing utilities

Includes Pictor, a full-featured paint program, completely integrated with Grasp for fast development and editing of programs and graphics.

GRASP 3.1
\$149

Convince yourself!
 Send us \$2.00 for Episode I "The Adventures of Ferguson Floppy"

Paul Mace
 SOFTWARE

400 Williamson Way
 Ashland, OR 97520
 800-523-0258

OUTSHINE THEM ALL WITH PHOTOMETRIC® SLIDEMAKER®

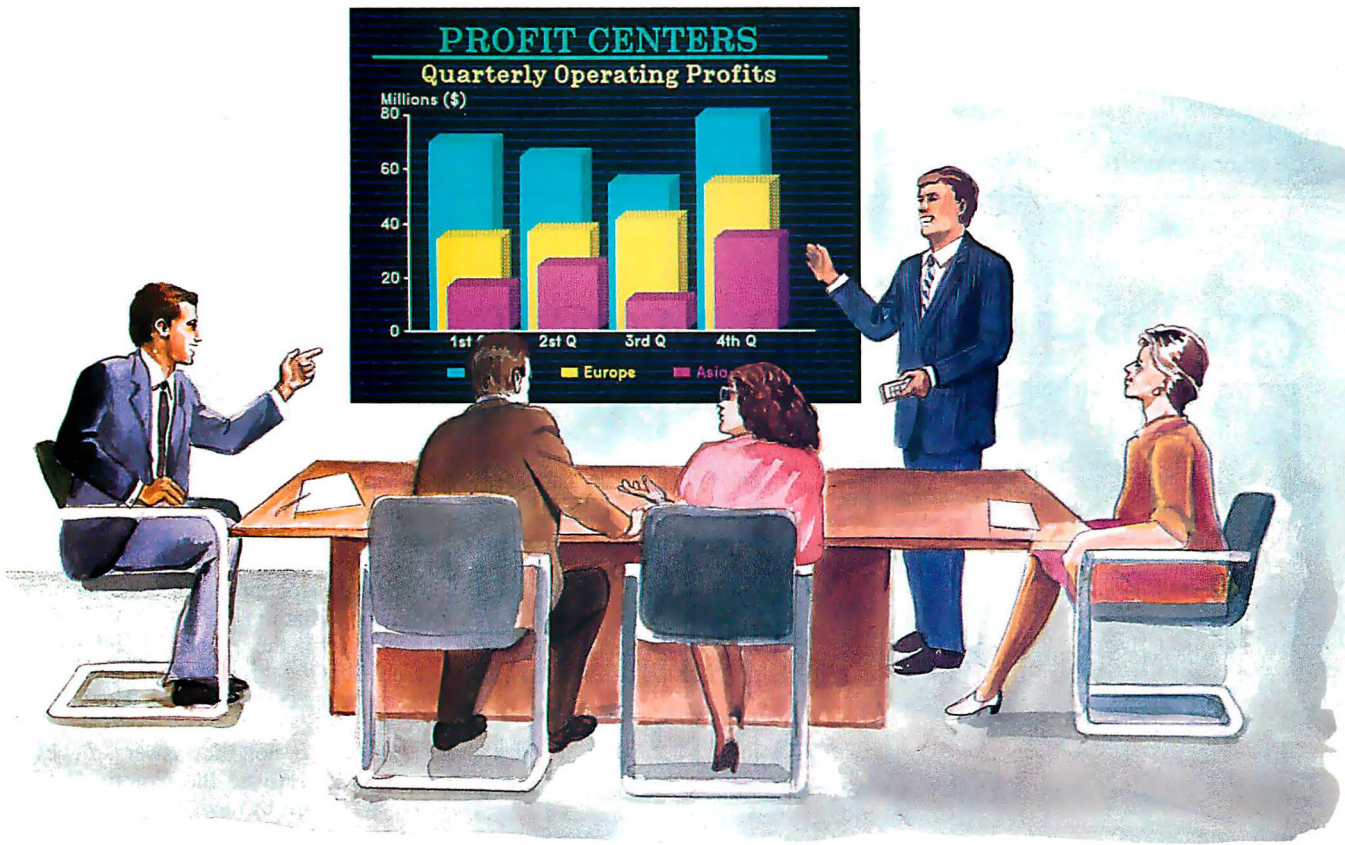

Make high-resolution slides with your PC or Macintosh®

With PHOTOMETRIC® SLIDEMAKER® you can quickly and easily produce professional-quality slides at your desk with 4K resolution and 100,000 brilliant colors in each slide. Advanced features like automatic text kerning for typeset quality and shaded backgrounds for dramatic effect and emphasis will make your slide presentations more impressive and persuasive than ever. And you can use most popular graphics and presentation software to create your slide images. PHOTOMETRIC SLIDEMAKER is so

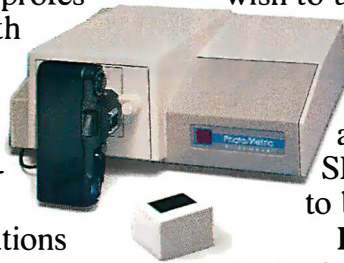

easy to use, all you do is select the film you wish to use and the images you want to shoot.

And in minutes your slides will be ready to develop. You can even view your images in high resolution and full color (even on a Mac® SE or Plus) before you shoot them to be sure they are picture perfect.

Find out about the price performance leader in desktop slidemaking. Call today! 800-556-1234 Ext. 234. In California, call 800-441-2345 Ext. 234.

Trademark/Owner: Mac, Macintosh/Apple Computer, Inc.; PhotoMetric, SlideMaker/General Parametrics Corporation.

General Parametrics Corporation Berkeley, CA 415-524-3950

The leader in desktop presentation products

Just to see if everything works, try moving the cursor in the Start a Program window to the OS/2 full-screen command prompt, then press Enter. You'll then see the familiar DOS-like C:\ command prompt. Run CHKDSK, and you'll find that OS/2 is installed into about 8 megabytes' worth of disk.

Adding DOS Back to the Disk

The IBM version of OS/2, as well as some other versions (Compaq's comes to

mind), lacks a *dual-boot* option. This means that, as I said before, the installation wipes the DOS boot files—IBMBIO.COM and IBMDOS.COM if you have IBM, or Compaq DOS, IO.SYS, and MSDOS.SYS for MS-DOS—off the hard disk. You can hand-install a dual-boot option, but believe me, it's no fun. Bolt Systems, a small software company, has developed a terrific solution, which it calls MultiBoot.

MultiBoot moves the OS/2 system

files and modifies the boot record on your disk so that DOS can be reinstalled with the SYS C: command. MultiBoot also lets you decide which is your default operating system. When you boot up your system, MultiBoot gives you a message like, "I'm going to boot DOS unless you press the Caps Lock key in the next few seconds, in which case I'll boot OS/2."

Once you've spent thousands of dollars on OS/2 and an OS/2-ready workstation, what's another \$49.95 to have easy access to DOS? Highly recommended. [Editor's note: *For more on MultiBoot, see "MultiBoot Brings OS/2 Back to Earth" on page 100.*]

One Last Step . . .

Now you're set up to play around with OS/2. Before you do that, however, do yourself a favor and be sure to kill the spooler.

In the OS/2 conference on BIX, Ray Duncan and a host of helpful people field numerous questions, but the most common one is something like, "I keep getting fatal error messages from the print spooler. What am I doing wrong?" The answer from the experts is always the same: Shut the thing off. It is, as they say in the business, brain dead. How, then, do you disable it?

Believe it or not, the answer isn't obvious. First, activate the Control Panel. You can do this by navigating through the PM menus, or you can just create an OS/2 full-screen command prompt, then type PMCPL. Then pull down the Setup menu and select Spooler Options. You'll receive a box labeled "Spooler is selected" with an X in it. Just click on the X with your mouse, and "Spooler is not selected" will appear. The next time that you reboot, the spooler will not appear. Eventually, these spooler problems will be resolved. But for now, you should just disable it.

Next Month

Just what *are* all those 8 megabytes? How can I set up PM to start programs by themselves or in windows? Find out the answers to questions like these and yet more. ■

Mark Minasi is a managing partner at Moulton, Minasi & Company, a Columbia, Maryland, firm specializing in technical seminars. He can be reached on BIX as "mjminasi."

Your questions and comments are welcome. Write to: Editor, BYTE, One Phoenix Mill Lane, Peterborough, NH 03458.

GRAPHICS FOR MAC II®

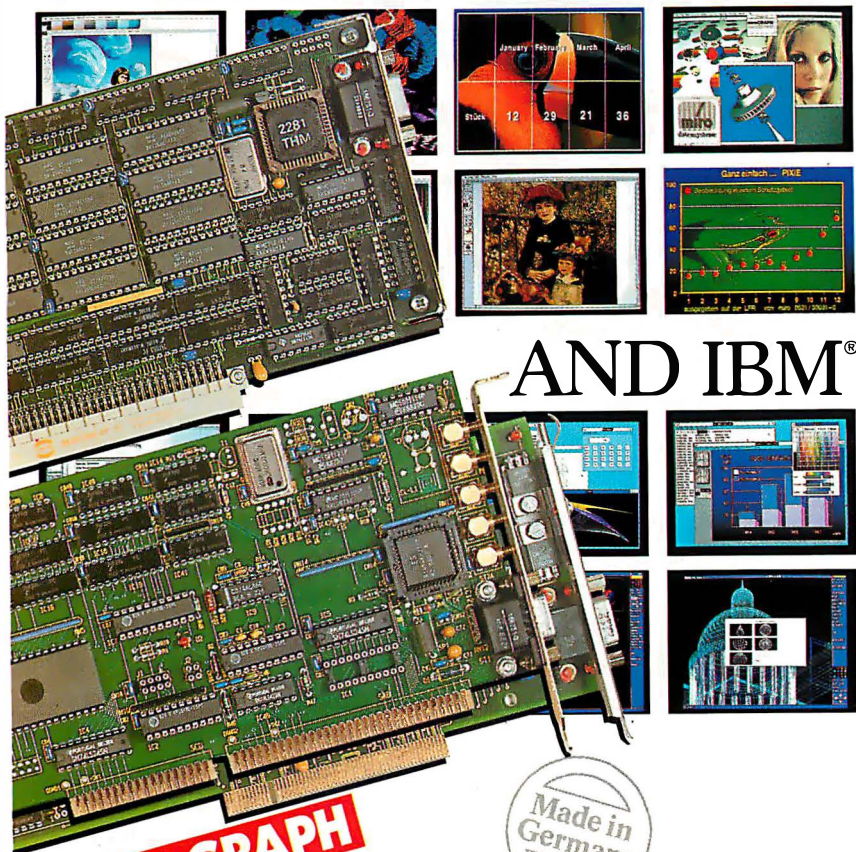

miroGRAPH

Flickerfree Display
72 dpi and 75 Hz refresh rate are the common features of these boards. You can choose: 256 colors, 256 greyscales or black and white. Compatible with any software based on the Apple Color Dick Draw.

Highest Resolutions
miroGRAPH graphics boards for PC/ AT and PS/2 are featuring resolutions of 1024 x 768, 1280 x 1024 or 1600 x 1200. Drivers for major software products are supplied with our boards. Ask for our actual compatibility list.



USA: Philadelphi, Booth 5406
MacWorld, Amsterdam,
Booth 3206, Deltahall



USA: miro, 27758 Santa Margarita Pkwy., Suite 285, Mission Viejo, Ca 92691, Phone 1-714-380-1120, Fax 1-714-5822873
Germany: miro, Gifhomer Str. 28, 3300 Braunschweig, Phone: 49-531-30091-0, Fax 49-531-30091-99, Apple Link GER.XSE0012

ZORTECH

T · E · C · H · N · O · L · O · G · Y

C DEBUGGER \$89.95

Zortech's Debugger is the most sophisticated source level debugger now available. Because it is fully compatible with Codeview you can use it to debug Zortech or Microsoft programs.

Single step through source in one window while watching the variables (inc. automatics) change value in another window. You can even alter variables dynamically while the program executes.

Much better than Codeview, and full of advanced features like dual monitor, EMS memory and Mouse support. Call for data sheet.

C VIDEO \$299.95

Learn C Now! When you buy our C Course the first lesson you learn is in economics. You will save yourself or your company hundreds of dollars in seminar tuition fees.

You get ten one hour tapes containing 36 lessons ranging from the beginners introduction through to more advanced features.

Great for learning C! Any compiler and any operating system. Complete with 365 page workbook (additional copies available at \$29.95) and free Zortech C compiler - Call for data sheet.



HELP! TECHNICAL HOTLINES

All our products are covered by an extensive FREE technical support hotline which is open five days a week from 9.00 till 5.00 (EST)

USA HOTLINE

617-646-6703
Fax: 617-648-9340

OUTSIDE USA

44-423-501552 (England)
Fax: 44-423-530746 (England)

C COMPILER \$89.95

The most advanced C compiler money can buy. No junk - just pure performance. Magazines are too embarrassed to print our optimized benchmark results - they don't want to upset the big guys!



BOTH FOR \$149.95

The 600 page manual comes with a great introductory section and lots of solid technical data and examples. Fully compatible with Codeview and the new Zortech C Debugger. You get over 400 functions and the Flash Graphics package with drivers for Hercules, CGA, EGA and VGA - the fastest graphics library available! Context Sensitive Help, an advanced editor/environment, make, touch, five memory models, linker & librarian. Library Source only \$89.95 - Call for data sheet.

C++ COMPILER \$149.95

This is the world's only true C++ compiler for MS-DOS machines - there is no choice. Not to be confused with 'translators' which are slow, expensive, inefficient and not real C++ compilers.

More people use Zortech's C++ than any other C++ on any operating system. Zortech strives to ensure full compatibility with AT&T C++.

Zortech C++ contains all the features of Zortech C including the C compiler itself at no extra cost. Everything is in one neat package. Compatible with Codeview and the new Zortech Debugger. C++ Library Source only \$149.95 - Call for data sheet.



ZC/TC/MSC TOOLKITS from \$49.95

Please state which compiler you have.

COMMS - \$99.95

Full Communications library with support for up to 8 ports, Xmodem, Kermit, ANSI, VT52, VT100, up to 38,400 baud, etc. 120 page manual.

BTREE - \$79.95

A database function library for C, complete with example program and over 50 functions. Easy to use with 92 page manual.

WINDOWS - \$69.95

Enhance your application with easy to use multiple text windows. Full demo program including 90 page manual.

PROSCREEN - \$69.95

Generates C source code for your application from screens that you draw. Too many features to list.

NEW! C++ VIDEO AVAILABLE NOW!

Please request full data sheets.

C++ TOOLS \$99.95

Zortech's toolkit of base C++ classes covering a wide range of common programming tasks such as bit vectors, singly and doubly linked lists, dynamic and virtual arrays, binary search tree, hash table, BCD maths, time/date/clock, directory lists, filenames, interrupt and critical error handlers, string editing, text windows and editing.

The 450 page manual also acts as a C++ tutorial which introduces the C programmer to the world of C++. Call for data sheet.



BOOKS

- C Primer (Sams) - \$23.95
- Advanced C Primer (Sams) - \$23.95
- C++ (Stroustrup) - \$29.95
- Ops & C++ (Wiener) - \$27.95

ORDER HOTLINE
1-800-848-8408

VISA/MC/COD

Prices do not include shipping

Circle 299 on Reader Service Card



Zortech, Inc., 1165 Massachusetts Avenue, Arlington, MA 02174. (617)-646-6703. Fax: (617)-643-7969.

Outside USA: Zortech Ltd., 106-108 Powis Street, London SE18 6LU, England. (44 -1)-316 7777. Fax: (44-1)-316 4138.

Dazzling Performance.



'286/SS

Complete 12MHz '286
with 32MB Hard Drive!
Only \$1395.00

It's the fastest '286-12 you can buy. Workhorse of the industry. Rugged from the ground up. This true Zero-Wait state system features a fast Seagate auto-park hard drive. Nothing can touch it!

- 80286-12 CPU, 6/12MHz Dual Speed keyboard/hardware selectable. Reset and Turbo buttons right up front.
- Zero-Wait State DRAM, 512K expandable to 4MB on the motherboard (16MB System Total). EMS capability!
- Fast 32MB Seagate 138R Hard Drive with auto-park, 1.2MB Floppy Drive.
- Ultra high speed Hard/Floppy controller. 1:1 interleave, 800 KB/sec transfer rate.
- High-Res Amber Display, Tilt/Swivel Base.
- ZEOS Enhanced 101 Key Keyboard, with Pleasant Tactile/Click Feel.
- Serial and Parallel Printer Ports.
- Clock/Calendar with Battery Backup.
- 6-16 and 2-8 bit expansion slots.
- 80287 support, up to 12MHz.
- Heavy Duty Case complete with Security Lock and LED indicators.

20MHz '286 HARD DRIVE SYSTEM
286/20—At 20MHz, the fastest '286.
Complete with our 32MB, 33ms Hard Drive and 1MB RAM. This is what Dazzling Speed is all about. Only \$2095.00

If you're buying a new computer, ZEOS® is your best choice. Why? Because ZEOS custom builds the best computers money can buy and sells them *factory direct* to you. *PC Resource Magazine* put it this way, "ZEOS...provides quality comparable with the IBM or Compaq and does so for about 70% of the cost."

And a recent review in *PC Magazine* said "comparing the ZEOS with a typical clone is a bit like comparing the Space Shuttle Booster rocket with a helicopter rotor... If you're looking for one of the fastest rides around at a down-to-earth price, don't pass up the ZEOS. Solid construction, flexible design and escape-velocity performance make it a top flight choice."

We couldn't have said it better ourselves.

That's why ZEOS is fast becoming the *preferred choice* of corporate, government and institutional buyers around the world. That's why it's the best choice for you.

So pick out your dream machine and order it now with

confidence. Dazzling performance and incredible prices await you. *Guaranteed.* Order now by calling 800-423-5891.

YOUR BEST CHOICE!

We don't just say it. We guarantee it. Your new ZEOS system comes with a Full One Year Limited Warranty and our 30 day Full Refund Satisfaction Guarantee. Fully Compatible and Rock Solid. Your best choice without question.

Incredible Prices.

Options Galore. As *PC Magazine* said, "more options than even the most configuration-hungry-hound could possibly need." Including 14" EGA, add \$495. 14" VGA, add only \$695. An incredible selection of hard drives and virtually any other add-on you could want. Call now Toll Free for details 800-423-5891.

All prices and specifications are subject to change without notice. Please call for current pricing and warranty details. ZEOS is a publicly traded company: MPLS/St. Paul Local OTC. ©1989 ZEOS International, Ltd., 530 5th Avenue, N.W. St. Paul, MN 55112



'386SX

The New ZEOS 386SX Hard Drive System. Below '286 Prices!
Only \$1895.00
The future is now!

PC Magazine says "386SX-based machines are the right choice..." the new ZEOS 386SX is why. The future is yours now, with the new ZEOS '386SX. It's even priced below comparable '286 systems!

- 80386SX-16 CPU, 8/16MHz Dual Speed Keyboard Selectable. Reset/Turbo buttons.
- Zero-Wait State DRAM, 512K expandable to 4MB on board (16 MB System Total).
- Shadow RAM and EMS capability.
- Fast 32MB Seagate 138R Hard Drive, 1.2MB FDD
- Ultra high speed Hard/Floppy controller. 1:1 interleave, 800 KB/second transfer rate.
- High-Res Amber Display, Tilt/Swivel Base, compatible graphics controller.
- ZEOS Enhanced Tactile/Click keyboard.
- High Speed Serial and Parallel ports.
- 6-16, 2-8 bit expansion slots. 80387SX Math coprocessor support.
- ZEOS space saver case. Including Security Lock and LED indicators.



'386DT

Complete ZEOS 20MHz '386 Desktop System. 65 MB Drive!
Only \$2995.00
16 MHz systems also available!



The new '386 desktop standard. Featuring our 64K CACHE (twice that of most competitors) providing Zero-Wait State performance vastly superior to page/interleave memory schemes. Incredible value.

- High speed Zero-Wait 64K SRAM CACHE.
- Genuine 32-bit Intel 80386-20MHz CPU.
- 1MB of Zero-Wait DRAM Expandable to 16MB System Total.
- Fast 65MB Seagate Hard Drive, 1.2MB Floppy Drive.
- Ultra high speed Hard/Floppy controller, 1:1 interleave, 800 KB/sec transfer rate.
- High-Res Amber Display with Tilt/Swivel Base, compatible graphics controller.
- 101 Key ZEOS Tactile/Click keyboard.
- High speed Serial and Parallel Ports.
- 1-32, 5-16 and 2-8 bit slots.
- 80387 math coprocessor support.
- ZEOS 5-bay case. Including Security Lock and LED indicators.



'386/V

Complete 25MHz '386 Vertical System. 65MB Drive!
Only \$3995.00
33MHz systems also available!

ZEOS 25MHz and 33MHz 80386 systems are the fastest, most advanced available anywhere. Review after review, these ZEOS systems are selected as the best price/performance buys. A power-user's dream.

- High Speed Zero-Wait 64K CACHE.
 - Genuine 32-bit Intel 386-25 or 33MHz CPU.
 - 1MB Zero-Wait 32-bit DRAM expandable to 8MB on board plus 16MB 32-bit expansion (24MB total).
 - Fast 65MB Seagate Drive, 1.2MB FDD.
 - Ultra high speed Hard/Floppy controller, 1:1 interleave, 800 KB/sec transfer rate.
 - High-Res Amber Display, Tilt/Swivel Base.
 - 101 Key ZEOS Tactile/Click keyboard.
 - High Speed Serial and Parallel Ports.
 - 1-32, 6-16 and 1-8 bit slots.
 - 80387 and Weitek 3167 support.
 - Heavy Duty 6-bay Vertical Case.
- Desktop configurations also available.

Order Now Toll Free

800-423-5891

FAX Orders Dial: 612-633-2310
 In Minnesota Call: 612-633-4591
 MasterCard, VISA and COD
 Open days, evenings and weekends
 Se habla Español.

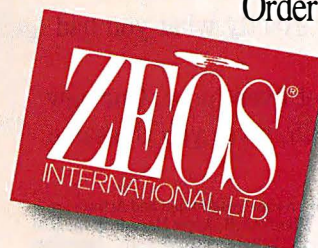

Now Artisan Is Bigger Than Ever Before. Introducing E Size.



Introduced last year, Artisan's easy to use, full-featured, high performance resulted in what the industry now recognizes as a new standard in pen plotters. Editorials in leading publications recommend Artisan. Most importantly, you've made Artisan the No. 1 selling pen plotter we provide.

Well, it makes sense. We designed Artisan to deliver exactly what you had in mind.

And now you get even more. Our new Artisan, Model 1025, gives you the same

speed, accuracy, reliability, and resolution quality that made Artisan famous.

Together with the ability to output a full range of plots. From A to E size.

Fully compatible with the IBM PC and PS/2 families, DEC MicroVAX II, Apple Macintosh, as well as over 100 of the most popular CADD software packages, Artisan delivers what it promises. Plots at speeds up to 42 ips. Pens that keep moving at high speed around corners, curves and circles. Lines that are sharp and true at every angle. Add to that Artisan's high-resolution (.0005 inches), 2.8g acceleration, eight pens in any combination of ink color and pen type, low list price and the support system CalComp is famous for, and you've got even more than you bargained for.

If Artisan sounds like exactly what you had in mind, call CalComp at 1-800-CALCOMP. Or write us at CalComp, P.O. Box 3250, Anaheim, CA 92803. In Canada, call (416) 635-9010.

We draw on
your imagination.™

 **CalComp**
A Lockheed Company

©1989 CalComp Inc. We draw on your imagination and Artisan are trademarks of CalComp. DEC MicroVAX II, Apple Macintosh and IBM PS/2 are registered trademarks of Digital Equipment Corp., Apple Computer, Inc., and International Business Machines Corp., respectively.



THE MAC MAKES CONNECTIONS

Several new products give the Mac real connectivity clout

References to the Macintosh in this column have been conspicuous by their absence. There are a few reasons for this apparent oversight. First, whether you're using a Commodore 64 or a Cray X-MP, moving bits through a telephone line or over a satellite link is accomplished in basically the same manner.

Second, I don't harbor any ill will toward the Mac, but I don't want to pony up the money for another machine to replace the one I have that works just fine. However, Apple has poured a lot of money into the Mac to equip it to take over the desktop publishing realm. As such, it's demanding better connections with the rest of the computer world.

At the recent MacWorld Expo, I saw several products that indicated a definite push toward connectivity. These weren't rushed or poorly thought-out products, but solid, well-planned devices and programs. What follows are some of the highlights.

Tour de Force

3Com put on quite a spectacle while introducing its connectivity products. Bill Krause, 3Com's president, lifted passages from several of President Bush's speeches during a press conference, claiming, "This has nothing to do with a thousand points of light, but may have to do with a thousand connections."

A heavyweight panel marshaled by 3Com during its press conference included former Apple evangelist Guy Kawasaki (now vice president of Acius) and Bill Campbell, president of Claris, who gave testimony to 3Com's newest products: An EtherLink/SE card and an



enhanced version of 3+ for Macintosh LAN software.

Users of Macintosh-based LANs such as LocalTalk are locked into data transfer rates of about 230,000 bps. Although this speed is fine for small networks, large applications normally require Ethernet LANs with data transfer rates of 10 megabits per second. The EtherLink/SE card gives SE users on a LocalTalk network access to Ethernet speed.

In the benchmarks I saw, there was no contest between the performance of the EtherLink/SE card and the LocalTalk network; the EtherLink/SE card was clearly the winner. This card is especially handy for anyone who uses database applications or runs a desktop publishing program, such as PageMaker, over a network. These two applications ran as much as five times faster using the EtherLink/SE card.

The migration from LocalTalk to Ethernet is a snap, literally. The card snaps into the SE slot, and you can hook

up the cable in 10 minutes. Using the EtherLink/SE card, you could, for example, go from a PhoneNET network running LocalTalk to Ethernet performance on your current twisted-pair wires.

Enhancements to 3+ for Macintosh now allow Macs on Ethernet or LocalTalk networks to use IBM PCs as servers. One Macintosh wag claimed, "The only real use for a 386 is as a server, anyway." 3+ for Macintosh software has supported the IEEE 802.3 Ethernet network adapters since 1987, but with the enhancements, it now supports Apple's LocalTalk PC adapter for PC servers as well.

This new version of 3+ software also fills a void: remote dial-in support for Mac networks. With remote access, you can share data locally or with a geographically separated site. This means that from home, you can access either your Mac or a PC server.

In addition to providing remote dial-in

continued

access, the E-mail capability has been upgraded. The 3+ for Macintosh mail enhancements give Mac users "point and click" access to a list of all the individuals and groups on the network, without requiring the user to know correct spelling or server location. The enhanced mail features also include sorting of E-mail by sender, receiver, message date, or subject, and they provide automatic retrieval of mail in the background.

The E-mail industry has been trying to standardize auto-retrieval for some time. In fact, the new CCITT X.500 standard proposes this type of directory access. 3Com is definitely ahead of the game in this respect.

More Ether

Farallon Computing's PhoneNET system is about to get better. This system allows Macs to be configured on a network using simple twisted-pair phone wires. As good as PhoneNET is, it was still hampered by the 230,000-bps data transfer speed of LocalTalk. Not any more.

Farallon's newest product is an Ethernet connector that will allow PhoneNET users to upgrade to Ethernet speeds of 10 megabits per second. It has no formal name or model number yet, and it's not shipping yet. Farallon showed me how its new connectors will allow PhoneNET users to set up parallel PhoneNET systems in the same modular design as current LocalTalk PhoneNET systems.

The concept is strikingly simple. By using a series of modular connectors, controllers, and repeaters, you will be able to integrate an Ethernet-speed network into a working PhoneNET system. (The controllers handle the network management function, and the repeaters extend the range of a network.)

Viewing this new Ethernet setup, I saw nothing mysterious. The hardware is basically the same simple design as that of PhoneNET—except that, with the new configuration, you can operate at Ferrari-like speeds. The twisted-pair wiring and the plug-in connectors to the back of the Mac are the same. The connectors hook into Farallon's StarControllers, which are typically located in the telephone wiring closets. The controllers are then connected to the repeaters.

Farallon's design and implementation have a kind of simple elegance. Following this parallel network architecture scheme, even I could install an Ethernet-based network.

Larry Jones, Farallon's product manager, assured me that the new Ethernet products are IEEE 802.3 compatible. He

ITEMS DISCUSSED

EtherLink/SE\$595
3+ for Macintosh Enhanced
 (due to be shipped in April)\$495
 3Com Corp.
 3165 Kifer Rd.
 Santa Clara, CA 95052
 (408) 562-6400
Inquiry 1071.

MacMainFrame SE.....\$795
MacMainFrame SE/30\$995
 Avatar Corp.
 65 South St.
 Hopkinton, MA 01748
 (508) 435-3000
Inquiry 1073.

PhoneNET Ethernet connector.....\$1000
 (estimated cost per node; not yet shipping)
Timbuktu/Remote\$295
 Farallon Computing, Inc.
 2201 Dwight Way
 Berkeley, CA 94704
 (415) 849-2331
Inquiry 1072.

TeleBridge.....\$499
 Shiva Corp.
 155 Second St.
 Cambridge, MA 02141
 (800) 458-3550
Inquiry 1074.

also noted that the product will fully comply with the 10 Base T (emerging) standard designed for Ethernet on twisted-pair telephone wires.

I also looked at Farallon's Timbuktu/Remote screen-sharing software. Shared screens are something of a late-comer LAN application (if you don't count Doug Englebart's pioneering On-Line system developed back in the mid-1970s). In fact, screen sharing can be considered the fourth major LAN application after printer access, file service, and E-mail.

Screen sharing gives two people simultaneous access to the same information on both screens. Moreover, each user can manipulate the information on the other's screen from the local keyboard. Not only does screen sharing save you from going to another office just to confer over something, it eliminates having to crowd several chairs around the small Macintosh screen.

Farallon's first Timbuktu program was designed for screen sharing. But now with Timbuktu/Remote, those who

are sharing that screen can be on opposite coasts, operating on separate LANs.

You can efficiently handle this process by tying together the two physically separated LANs via a high-speed modem. Once the link is established, a Boston user can control a San Francisco user's screen, and vice versa, just as if they were in the same room sitting at the same computer. The possibilities for this application are legion. Customer support suddenly takes a real-time approach. Researchers and educators can collaborate in real time.

When I used Timbuktu/Remote, I was able to perform several functions, including deleting files on the remote system (don't panic; it has a full security system, so only an authorized user can delete files) and writing to the remote computer's disk. I was able to select options such as "observe only," which, if needed, would have let me show the remote user a particular "how to" process without his or her interfering.

I was also able to transfer several files in either direction. The program created a "files received" folder on the Mac I was using, so I didn't have to hunt for the newly arrived files. I wasn't locked into this procedure, however, and I could have specified the folder in which I wanted to put the files. Should you want to transfer files and be productive at the same time, all these functions work in the background.

With Timbuktu/Remote, you also can set up your computer as an unattended host, so that you don't have to wait up for your late-night colleague. While you're watching "Late Night with David Letterman," on TV, your colleague can access your Mac. Of course, several layers of password security are built in, so you can tailor a remote user's access to your liking.

Hardware Bytes

All this connectivity is dependent on hardware of some sort. Two new products that I saw at MacWorld Expo bring this into sharp focus.

The first product is aimed at Apple's new Mac SE/30. With all the added horsepower under the SE/30's hood, Mac-to-mainframe connectivity should be a natural. With Apple's official announcement of the SE/30 only minutes old, Avatar Corp. announced MacMainFrame SE/30, a card and software combination with which you can connect the SE/30 to an IBM 3720 network. With this software, you can achieve full IBM 3278/79 terminal emulation and file

continued



Our Printer Sharing Unit Does Networking!

An Integrated Solution

Take our **Master Switch™**, a sophisticated sharing device, combine it with **MasterNet™** networking software for PCs, and you've got an integrated solution for printer and plotter sharing, file transfer, electronic mail, and a lot more. Of course you can also share modems, minis, and mainframes or access the network remotely. Installation and operation is very simple.

Versatile

Or you can use the Master Switch to link any computer or peripheral with a serial or parallel interface. The switch accepts over 20 commands for controlling the flow of data. It may be operated automatically, by command, or with interactive menus. Its buffer is expandable to one megabyte and holds up to 64 simultaneous jobs. The

MasterLink™ utility diskette for PCs comes with every unit and unleashes the power of the switch with its memory-resident access to the commands and menus.

Other Products

We have a full line of connectivity solutions. If you just want printer sharing, we've got

it. We also have automatic switches, code-activated switches, buffers, converters, cables, protocol converters, multiplexers, line drivers, and other products.

Commitment to Excellence

At Rose Electronics, we're not satisfied until you're satisfied. That's why we have thousands of customers around the world including large, medium, and small businesses, factories, stores, educational institutions, and Federal, state, and local governments. We back our products with full technical support, a one-year warranty, and a thirty-day money-back guarantee.



**ROSE
ELECTRONICS**

**Call now for literature or
more information.
(800) 333-9343**

Give a Rose to your computer

transfers under IBM's CICS, TSO, and CMS operating environments.

When I used the MacMainFrame card, I liked the full-keyboard mapping that the software provided. There are also pull-down menus and cut-and-paste support for grabbing that particular piece of information from the main-frame.

But not all user interfaces are created equal. The solution? Create your own if you can. With MacMainFrame, you can.

Avatar provides a programmer's toolkit that comprises Avatar's API, HyperCard API, and MacWorkstation TLPM, for development of customized interfaces. I cajoled a programmer-type friend, who works at the UC San Diego Supercomputer Center, into giving API a quick run-through. He was pleasantly surprised. I trust his judgment, and I'll pass it along to you. His assessment was "Primo."

The other piece of hardware at Mac-

World Expo that impressed me was a modem-like device from Shiva called the TeleBridge. With this bridge, you can link geographically distributed LANs across the street, across the continent, or across the world. All you need is a clean phone line and a high-speed modem.

The TeleBridge is compatible with PhoneNET and LocalTalk networks and operates at speeds of up to 57,600 bps. (You'll need a leased line to get the maximum performance out of the modem.) TeleBridge weighs in at just 3 pounds and is small enough to fit on a desktop without intruding.

In the physical network, the TeleBridge sits right before the modem, and you'll need one on each end to make the whole setup work. The TeleBridge isn't multiplexed, however, and if someone else gets to it first, you'll have to wait to use it.

Shiva also includes Dial-In Network Access software, a nice touch. Essentially, with this software, you can dial into your local LAN, access the TeleBridge, and then access the remote LAN on the other end of the TeleBridge.

Shiva further includes Internet Manager software. Using this product, you can achieve network administrative control of both networks. You just plug in two connectors, connect the modem, and turn on the power. With the Internet software, any Mac on the network can act as an administrator. Thus, you can group networks into zones, control network traffic, and, if you desire, restrict access between zones.

Lead, Follow, or Get Out of the Way
There were several other network-related products that I didn't get to try out at the MacWorld Expo, but from the volume of products announced, it looks like Mac connectivity is certainly coming into its own.

From the days when company personnel smuggled their first Macs in through the back door, to today's purchase orders for Mac IIs, a lot has changed. Corporate MIS departments can no longer ignore the Macintosh as a viable computing resource. From all the products just announced, it's clear that Mac connectivity is on the front burner. ■

Brock N. Meeks is a San Francisco-based freelance writer who specializes in high technology. You can reach him on BIX as "brock."

Your questions and comments are welcome. Write to: Editor, BYTE, One Phoenix Mill Lane, Peterborough, NH 03458.

CONNECTIVITY SOLUTIONS!

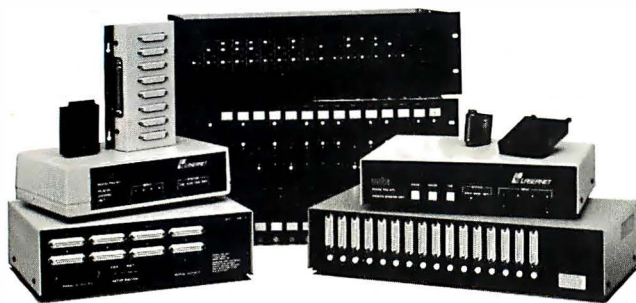

INNOVATIVE DATA COMMUNICATIONS PROBLEM SOLVERS

64 PORT NETWORKING

With the new INC-64 Intelligent Network Controller you can create your own "Any-Port-to-Any-Port" network, linking up to 64 terminals, modems, printers or computers. It's the perfect low-cost solution for connecting more users to your computer or sharing multiple computer systems; as well as modem pooling, data acquisition, printer sharing or PC to PC networking.

FEATURES INCLUDE: Individual port configuration, up to 2MB of buffering, access security, audit trail output, monitor/broadcast and mailbox capabilities. Expandable in 8 port plug-in modules. Pop-up port select and terminal emulation software. Plug-in multiplexers, line drivers and port splitters are available.

COMPUTER CONTROLLED SWITCHING



Your Computer Can Code Select Up To 64 Serial Ports!

The CAS-161 Code Activated Switch enables the COM port on your PC to switch to one of 64 user ports. The computer can select ports individually or broadcast to all ports.

APPLICATIONS INCLUDE: Data acquisition, down loading robotic and machine tool controllers, directing data to multiple printers, modems or other data equipment.

PRINTER/PLOTTER SHARING

Our Lasernet® printer sharing products let you make more efficient use of your expensive printers and plotters. Up to eight users can quickly and easily share any two printers or plotters. Save time too, by off-loading data into Lasetnet's 256K to 2MB buffer. A simple menu driven configuration program makes installation easy!

Lasetnet is the professional printer sharing solution for DeskTop publishing and CAD applications. It's compatible with virtually all popular software. Several models and memory options are available to meet your price and performance requirements.

QUALITY

Every WTI product is designed and manufactured with quality and reliability as major requirements. We're so confident you'll like our products we offer a 30-day return policy in addition to our 36 month warranty.

THERE'S MORE IN OUR FREE CATALOG...

Data PBX Switches, Port Selectors, Data Acquisition Equipment, Data Buffers, Modems and Data Distribution Systems. It's your connectivity solution... just ask for it!

Call toll free:

1-800-854-7226 (in California 714/586-9950)

wte western telematic inc.

5 Sterling, Irvine, CA 92718 • Telex 467741 • Fax 714/583-9514

CHEAP!



ZENITH

SUPERSPORT 2 Drive \$ 1493
 SUPERSPORT 20MB HD \$ 2218
 SUPERSPORT 286 20M \$ 3079
 SUPERSPORT 286 40M \$ 3588
 TURBOSPORT 386 40M \$ 5096
 2400 CRACKER MODEL \$ 258
 Weltec 5.25" 360K Drive \$ 198
 Weltec 5.25" 1.2M Drive \$ 248



Seagate

SEAGATE
 ST-225 20M 65ms \$ 218
 ST-225 20M & cont \$ 267
 ST-238 30M & cont \$ 296
 ST-251 40M 40ms \$ 359
 ST-251 40M & cont \$ 424
 ST-251 & 16 bit cont \$ 458
 ST-251-1 40M 28 ms \$ 428
 ST-251-1 & 16 bit cont \$ 544
 ST-4096 80M 28ms \$ 559

HARD DISK DRIVES



TOSHIBA

T1000 \$ 835
 T1200F \$ 1392
 T1200FB \$ 1548
 T1200H \$ 2244
 T1200HB \$ 2397
 T1600 \$ 3248

T3100E \$ 3078
 T3200 \$ 3669
 T5100 \$ 4859
 T5200/40 \$ 6288
 T5200/100 \$ 7129



AST

COMPUTER SYSTEMS

Bravo 286 Model 5 \$ 899
 Bravo 286 Model 45 \$ 1496

Premium Computers
 286 Model 80 \$ 1448
 286 Model 90 \$ 2010
 286 Model 120 \$ 2318
 286 Model 140 \$ 2677
 286 Model 170 \$ 2988
 386 Model 300 \$ 2699
 386 Model 340 \$ 3999
 386 Model 390 \$ 5349
 386 Model 3150 \$ 6244
 386 Model 3320 \$ 6788



EPSON

Equity I+ \$ 728
 Equity Ie \$ 749
 Equity II+ \$ 1089
 Equity III+ \$ 1344

LT Laptop Dual Drive \$ 1189
 LT Laptop 20M Harddisk \$ 1792

Monitor sold separately



NEC

Powermate

1 Enh. 10MHz \$ 1239
 2 \$ 1567
 SX 2MB 42M \$ 2729
 SX 2MB 140M \$ 3619
 386/16 \$ 2644
 386/20 \$ 3475

All Original NEC Components
 All Models Include Keyboard

Monitor sold separately



NEC

Powermate Port. 20M \$ 2639
 Powermate Port. 40M \$ 2989
 Powermate Port. SX 42M \$ 3944
 Multispeed EL II \$ 1488
 Multispeed HD \$ 2279
 Ultralite \$ 1984
 Prospeed 386 Model 40 \$ 4892
 Prospeed 386 Model 100 \$ 5744

Premium Workstations
 286 Model 200 \$ 1592
 286 Model 203 \$ 1812
 286 Model 205 \$ 1812
 286 Model 243 \$ 2555
 286 Model 245 \$ 2555

SPECIALS

ALDUS PAGEMAKER \$ 449
 XEROX VENTURA 2.0 \$ 474
 MICROSOFT EXCEL \$ 218

NEC MULTISYNC 2A \$ 498
 NEC MULTISYNC 3D \$ 639

LOGITECH Hand Scan \$ 198

DISK DRIVES

PLUS
 20M Hardcard \$ 498
 40M Hardcard \$ 629
 Passport 40M \$ 1029

TOSHIBA
 3.5" 720K \$ 88
 3.5" 1.44M \$ 126
 5.25" 360K \$ 89
 5.25" 1.2M \$ 89
 AMR 5.25" for PS/2 \$ 239
 AMDEK Laserdrive with MS Bookshelf \$ 799

MODEMS

HAYES
 1200B Internal \$ 229
 2400B Internal \$ 368
 1200 External \$ 268
 2400 External \$ 397
 2400P PS/2 \$ 392

US ROBOTICS
 1200 Internal \$ 95
 2400 Internal \$ 164
 1200 External \$ 99
 2400 External \$ 177
 SUPRA
 2400 Internal \$ 98
 2400 External \$ 138

VIDEO CARDS

Boc a EGA \$ 144
 Everex EGA \$ 128
 Hercules Mono + \$ 178
 Hercules Color NP \$ 139
 Hercules INColor \$ 272
 Nitro Monographic \$ 59
 Nitro Color Card \$ 59
 Paradise Autosw 480 \$ 199
 Paradise VGA Plus \$ 268
 Paradise VGA Plus 16 \$ 298
 Paradise VGA Prof. \$ 458
 Video-7 Vega VGA \$ 272
 Video-7 Fastwrite VGA \$ 356

SAMSUNG

S-300 \$ 649
 8 MHzXT Compatible
 360K Drive, 6 Exp Slots

S-500 \$ 1098
 10 MHz AT Compatible
 1.2M Drive, 8 Exp Slots

S-800 \$ 2598
 20 MHz 80386
 1.2M Drive, 8 Exp Slots
 EGA Video Adapter

MITSUBISHI

286 Laptop Dual Drive \$ 2188

286 Laptop 20M \$ 2498

NEC PRINTERS

P2200 10" wide \$ 359
 P5200 \$ 509
 P5300 \$ 662
 P5XL 16" Color \$ 877
 P9XL 16" Color \$ 1079

LC890 Silentwriter \$ 3433

ELF-350 19 cps \$ 417
 3500 35 cps \$ 896
 8800 55 cps \$ 1166

CITIZEN PRINTERS

120D \$ 184
 180D \$ 199
 MSP-15E \$ 369
 MSP-40 \$ 337
 MSP-45 \$ 488
 MSP-50 \$ 422
 MSP-55 \$ 551
 Premier 35 \$ 533
 Tribute 124 \$ 498
 Tribute 224 \$ 664

EPSON PRINTERS

LX-800 \$ 189
 FX-850 \$ 339
 FX-1050 \$ 488
 LQ-500 \$ 319
 LQ-850 \$ 519
 LQ-950 \$ 589
 LQ-1050 \$ 737
 LQ-2550 Color \$ 919
 DFX-5000 \$ 1389

OKIDATA PRINTERS

320 \$ 329
 321 \$ 463
 292 IBM Parallel \$ 416
 293 IBM Parallel \$ 533
 294 Color Parallel \$ 754
 393 \$ 944
 393 Color \$ 1045

LASERLINE 6 Par \$ 1348

PANASONIC PRINTERS

KK-P10801 \$ 198
 KK-P10911 \$ 218
 KK-P10921 \$ 344
 KK-P1124 \$ 329
 KK-P1592 \$ 436
 KK-P1595 \$ 492
 KK-P1524 \$ 555

KK-P3131 17 cps \$ 327
 KK-P3151 22 cps \$ 519

Laser Partner \$ 1738

PRINTERS

AST TurboLaser/PS \$ 3383

DICONEX 150 \$ 299
 DICONEX 300 \$ 378
 DICONEX 900W \$ 477

GENICOM
 4410 400 lpm \$ 4689
 4440 800 lpm \$ 5979

QMS PS-810 2MB \$ 4098

XEROX 4020 Color \$ 1088

SOFTWARE

Aldus Pagemaker 3.0 \$ 449
 Xerox Ventura 2.0 \$ 474
 Xerox Prof.Ext.2.0 \$ 388

Byline \$ 184
 GEM Desktop Publ. \$ 219
 PFS: First Publisher \$ 79
 Publisher's Paintbrush \$ 138

dBaseIV \$ 419
 dBase IV Developer's \$ 733
 RapidFile \$ 179
 Foxbase Plus \$ 184
 DBXL \$ 118
 DBXL LAN \$ 318
 QuickSilver Diamond \$ 318
 Clipper \$ 399
 Paradox \$ 438

SOFTWARE

Microsoft EXCEL \$ 218
 Quattro \$ 149
 SuperCalc 5.0 \$ 289

VP Planner \$ 58
 Allways \$ 89
 Baler Lotus Compiler \$ 398
 SeeMore \$ 49
 Sideways \$ 47

Quick C2.0 \$ 68
 Quick Basic \$ 68
 Microsoft C 5.1 \$ 288
 MS Macro Assembler \$ 99
 MS Fortran \$ 285
 Windows Developer Kit \$ 299
 Turbo C \$ 99
 Turbo C Professional \$ 158

SOFTWARE

Word Perfect 5.0 \$ 234
 Microsoft Word 5.0 \$ 228
 Wordstar Prof. 5.0 \$ 234
 Q & A Write \$ 115
 Sprint \$ 128
 Grammatik III \$ 64

Crosstalk 16 \$ 97
 Crosstalk Mark IV \$ 119
 Procomm Plus \$ 58
 Relay Gold \$ 152
 Carbon Copy \$ 118
 PC Anywhere 3.0 \$ 69
 Laplink Plus \$ 98

Turbo C \$ 99
 Yeager Adv Flight \$ 29

MONITORS

Amdel 410A \$ 138
 432 VGA Mono \$ 156
 732 VGA Color \$ 414
 1280 & video card \$ 638
 AST Monochrome \$ 129
 AST EGA Color \$ 477
 Epson Mono \$ 114
 Epson Color \$ 288
 Epson EGA Color \$ 368
 Genius Dimp Sys \$ 1288
 NEC Monograph \$ 1244
 NEC Multisync XL \$ 2075

MONITORS

NEC Multisync 2A \$ 498
 NEC Multisync 3D \$ 639
 NEC Multisync GS \$ 228
 NEC Multisync Plus \$ 858
 PGS HX-12 \$ 436
 PGS Max-15 \$ 264
 PGS LM-300 \$ 538
 PGS UltraSync \$ 539
 Texan Crystal View \$ 1434
 WYSE WY-700 \$ 717
 Zenith 149 \$ 209
 Zenith 1390 \$ 419
 Zenith 1490 \$ 584

ACCESSORIES

Printer Cable 6' \$ 9
 Printer Cable 10' \$ 14
 Parallel Adapter \$ 29
 Serial Adapter \$ 29
 GameAdapter \$ 19
 101 Keyboard \$ 68
 PS/2 Keybd Exten \$ 16
 PS/2 Monitor Exten \$ 21
 Xidex DS/DD Disks \$ 7
 Xidex 1.2M Disks \$ 13
 IBM 3.5" 1M Disks \$ 29
 IBM 3.5" 2M Disks \$ 58

SCANNERS

Logitech Hand Scan \$ 198

DEST PC Scan 1000 \$ 844
 DEST PC Scan 1020 \$ 1189
 DEST PC Scan 2000 \$ 644
 DEST PC Scan 2020 \$ 949

PGS LS-300 w/fnt \$ 688
 PGS LS-300 OCR \$ 929

INTEL

8087 4.77MHz \$ 99
 8087 8 MHz \$ 142
 80287 6 MHz \$ 179
 80287 8 MHz \$ 243
 80287 10 MHz \$ 289
 80387 16 MHz \$ 448
 80387 20 MHz \$ 689

Above Bd Plus 512K \$ 333
 Above Bd PS/2 \$ 404
 Inboard 386/PC Kit \$ 728
 Inboard 386/AT Kit \$ 1018

MOUSE DEVICES

MICROSOFT
 Mouse \$ 97
 With Windows 2.0 \$ 138

LOGITECH
 Mouse \$ 74
 WithLogiCADD \$ 118
 Publisher Mouse \$ 113
 HiRes Mouse \$ 86

Note: Specify either Serial or Bus Version

HOURS (E.S.T.)
 9-7 Monday-Friday
 12-5 Saturday

NITRO MICRO

120 West Main Street • CARMEL, IN 46032

800-382-3888



Please add 3% for shipping & handling. NO SURCHARGE FOR CREDIT CARDS and we do not charge until we ship. All items subject to availability and price change. All standard orders are sent UPS.



Seven great reasons to join BIX. The on-line service for computing professionals

*Over 200 microcomputer-related conferences:

Your BIX subscription connects you with experts on Macintosh, IBM PC and compatibles, the Apple II family, Amiga, Atari, and UNIX machines. Join our OS/2 conference and learn about the new presentation manager.

*Microbytes daily — the award winning on-line news service:

Get up-to-the-minute industry news and new product information covering the IBM, IBM-compatible, Apple Macintosh and workstation markets.

*The full text of BYTE Magazine:

Each month BIX publishes the complete text of BYTE available on-line before the magazine is printed. Plus each issue since August 1988 is available for searching.

*Vendor support:

Hundreds of hardware vendors and software publishers use BIX to support their products. Get answers about new releases and tips on how to use products.

*Software libraries:

Including libraries for PCs, Macs, Apple II, Amiga and Atari. Join the "FromByte" area to get listings from BYTE articles.

*Electronic mail:

BIX is the only service that offers binary mail attachments. Now you can send spreadsheets, pictures, word processing documents, or desktop publishing files. You can even use BIX mail to distribute software updates.

*New menu interface:

The new BIX menus provide a convenient map of the system and include powerful options like the BIX Index where you can search all the BIX conferences. The Quick Download option will collect all of your mail messages and new conference messages and send them to you saving valuable on-line time.

◆ ◆ ◆ What BIX costs: How you pay

One time registration fee: \$39

Hourly Charges:

| | Off-Peak | Peak |
|-----------------------|-----------------|-----------------|
| (Your time of access) | 7PM-6AM \$11 | 6AM-7PM \$20 |

Charge to Visa, Mastercard, American Express or ask about our corporate billing.

BIX Help Line

800/227-2983

603/924-7681 in New Hampshire

Join BIX right now:

Set your computer's telecommunications program for full duplex, 8-bit characters, no parity, 1 stop bit. Call 800/336-0149 and ask for your local Tymnet number. Dial Tymnet and respond as follows:

| Tymnet Prompt: | You Enter |
|---------------------------------|-----------|
| [x] [xx] or terminal identifier | a |
| login: | bix |
| name: | new |

After you register on-line you get the BIX Main Menu and you can begin to explore the exciting world of BIX.

BIX

One Phoenix Mill Lane, Peterborough, NH 03458 1-800-227-2983 ◆ In NH (603) 924-7681



NO POSTAGE
NECESSARY
IF MAILED
IN THE
UNITED STATES

BUSINESS REPLY MAIL

FIRST CLASS MAIL PERMIT NO. 42 HIGHTSTOWN, NJ

POSTAGE WILL BE PAID BY ADDRESSEE

BYTE

Subscription Department
P.O. Box 558
Hightstown, N.J. 08520-9409



If your idea of Romance Languages includes BASIC and C, then we have a great deal for you.

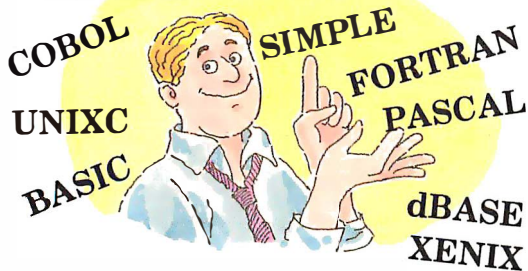

Packed with in-depth information on the latest in microcomputing, BYTE magazine is written to stimulate the minds of almost half a million personal computing experts. Now, you too can enjoy BYTE each month at our special introductory rate.

Subscribe now and save \$17 off the newsstand price...12 issues for \$24.95 instead of \$42.00...and \$5.00 off the regular subscription rate of \$29.95. You'll also receive our special IBM PC issue as part of your subscription!

IBJ0857

Name _____
(Please Print)

Company _____

Address _____

City/State _____

Country _____ Code _____

- U.S.A \$24.95 for 1 year
- Canada \$26.95 U.S. for 1 year
- Bill me
- Payment enclosed
- Charge to my () VISA () MasterCard
- Account # _____
- Expires _____
- Signature _____
- This is a renewal order.

For direct ordering, call toll free 1 800 257-9402 weekdays
9:00 AM-5:00 PM EST. In New Jersey, call 1 609 426-5535.

Please allow 6-8 weeks for processing your subscription.

BYTE



Display this month's
BIX activities:

M

A

TUESDAY, 5/2, 9 PM EST. "Which bus should you take to work?"

Some people who work in the IBM PC world prefer IBM's official Microchannel bus. Others are partial to the EISA bus. The pros and cons of each will be discussed at the IBM PC conference's regular "First Tuesday" session in May (after all, fare is fare). Come along for the ride. (join cbix, then select Band A, Channel 1)

THURSDAY, 5/11, 8 PM EST. "Live, from San Jose, it's DevCon"

Tune in David Szetela, Director of Developer Services, and find out what's been happening at the Apple Macintosh Spring Developer's Conference. (join cbix, then select Band A, Channel 1)

All-Month Conferences

Supermicros—Al Aburto, of the Naval Ocean Systems Center in San Diego, will join BIX moderators Ron Fox and Bill Nichols. Throughout the month, their topics will range from Unix to OS/2 to Pick to VM and VAX/VMS. Discussion may even extend to distributed systems, depending on your interest. (join supermicros)

R WARS—For 10 years, Unix advocates have divided into Berkeley and AT&T camps. But Berkeley faction leader Sun Microsystems announced a deal with AT&T to unify the two systems. Others rallied behind the Open Software Foundation's development of a Unix free from AT&T control. Find out more about the people, politics and technical merits of svr4, Motif, X/OPEN, POSIX and other Unix developments. (join rwar/unix.feud)

CAD—This month's CAD conference discussion, "Aspects of 3D CAD," will cover high-powered graphics for CAD—wire-frame vs. surface modeling, file interchange, etc. (join cad)

Uploads/Downloads

One of the major features of BIX is its Listings area—the place to find source and executable code for your computer, and to post programs and other information you want to share. Here's a sampling of what's in Listings, compiled by Sue Rosenberg, moderator of BIX's "other" group. The all-caps words starting each paragraph identifies the conference with which the files are associated.

IBM.PC: (Many picture files) "To-do" list, 386 fractals, unpack MAC "stuffit" file, graphic display of system configuration, hard disk utility, fractals for 386, drawings, golf handicap, rewrite floppy FAT. Latest ARC, DOS front end, financial

calculator, IBM Tech Reference replacement, Telix reference guide. Arithmetic for Turbo 4.0, chart maker, Apple MS-DOS compatibility guide.

C.LANGUAGE: Text reader, fast fourier transforms, more. INT 9 tsr, polynomial roots, case filter, string search.

IBM.AT: Pictures, along with ways to view them. Format 360K disks in 1.2 MB drive.

MACINTOSH: Pictures, desk accessories, game, Small-C benchmarks. Stack for developers, virus killers, Icon language, games, BYTE's Small-C benchmarks, read other stacks, explore stacks, show messages, field tabs, change startup to finder/multi-finder. Diagnose networks, bit operations and base conversions, prettifier, BIX blinking utility.

WRITERS: Hugh Kenner's Word Frequency Counter.

SUPERMICROS: Sieve benchmarks.

UNIX: Clear screen, grep/egrep source, security book programs, programs from Topics in C.

UTILITIES: Access ANSI.SYS, hard disk utilities, allow multiple boot configurations, automate 3270 actions, text editor, list utility, EEMs driver, compress programs, set clock to Naval Observatory time. Latest ARC, DOS front end, SEA vs. PK lawsuit, file compare and update, file transfer for MS-DOS, system information, time and date stamp. Boot control, file compare, menu generator, tech reference, rename directory, system info, word counter, keyboard utility.

BIX

One Phoenix Mill Lane ♦ Peterborough, NH 03458
1-800-227-2983 ♦ In NH (603) 924-7681



The Third Dimension

Three-dimensional modeling brings new excitement to microcomputer-based CAD

Brad Holtz and Jon Udell

To build a computer-based model of a three-dimensional object five years ago, you'd have had to use a graphics workstation. Although such machines and their software remain the tools of choice for those who can afford them, microcomputer-based modelers are coming fast.

You can use the packages we review here to design buildings, landscapes, gear assemblies, molecules, automobile bodies, or robot arms. In all cases, you construct a single model. From that can flow orthographic drawings, a bill of materials, rendered perspective views from anywhere outside or even inside the model, an animated tour made from a sequence of such images, an analysis of the static and dynamic physical properties of the *entities* represented in the model, and a program that instructs a machine tool to cut a copy of the model.

Because these downstream applications are various and complex and often require additional tools, they're largely outside the scope of this review. We'll look mainly at the process of 3-D modeling as implemented in a representative sample of CAD programs: AutoCAD, CADKEY, DataCAD, DesignCAD 3D, MaxxiCAD, Mega Model, MicroStation PC, ModelMate Plus, and VersaCAD Design (see table 1). (Also see the text

box "On the Horizon" on page 188 for a preview of three additional products—CADVance 3.0, FastCAD 3D, and SilverScreen—that were in late beta testing but should be available now.)

Most of these products are wire-frame-and-surface modelers: They can create what looks like a wire-frame model but actually represents a collection of planar surfaces. Three of the packages—DesignCAD 3D, ModelMate Plus, and SilverScreen—can attribute solidity to the space defined by such surfaces. These solid modelers herald an exciting new trend.

Within each school, the packages have very different personalities. Because 3-D CAD solves a highly complex problem—the abstract representation of physical structures—those personalities can be overwhelming. These programs are as big, powerful, resource-hungry, and difficult to master as anything you're likely to encounter on a DOS-based computer.

Some of these programs began as two-dimensional drafting programs and have grown into the third dimension, while others attacked 3-D modeling straightaway. Some appeal to mechanical engineers, others to architects and construction engineers. All provide modeling capabilities that existing CAD users have yet to fully assimilate and in some cases may not need. Those capabilities are redefining what is possible on a microcomputer and, consequently, enlarging the scope of the CAD market.

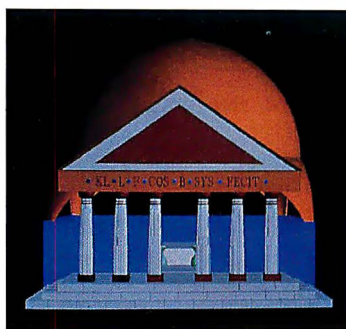

The BYTE Pantheon

To focus our interaction with the products, we specified the model illustrated in photos 1 through 6. Our pantheon, though architectural in spirit, exercises a range of general-purpose modeling capabilities. Some features are quite basic; others demonstrate complex capabilities. The steps, for example, are simple foot-thick slabs—entities that all the packages can create easily. But the columns are harder to construct. We specified a shape defined by a spline (a curve governed by a set of control points) and then constructed the shape by revolving that spline about a vertical axis—the center of the column—to create a tapered column.

Pendentives are the spherical/triangular arches that support the dome. For these, we specified a *surface patch* or *Coons patch*, which defines a complex surface bounded by four curves. Failing that, a triangulated grid gives a reasonable approximation. The sloping roof of the portico can have a ruled or meshed surface—whatever works best to display the intersection of the portico with the dome and the pendentives. Our design calls for the pendentives, the dome, and the walls of the main building to have a thickness of 2 feet.

An *oculus* (the hole at the top of the dome) points up the differences between surface and solid modelers. With solid modelers, you build a dome and then punch a cylinder through it. With surface modelers, your choices are to prepare an arc that, when revolved, creates the dome with the hole in place or, alternatively, to create a complete dome, slice through its top with a cutting plane, and attach a circle to the resulting arc endpoints.

[Editor's note: *The specification for the BYTE pantheon is available in a variety of formats. See page 3 for details.*]

We attempted the pantheon twice with each package. First, we built the model on our own, to get a feel for how each package treats an inexperienced user. Then we solicited and followed the ven-

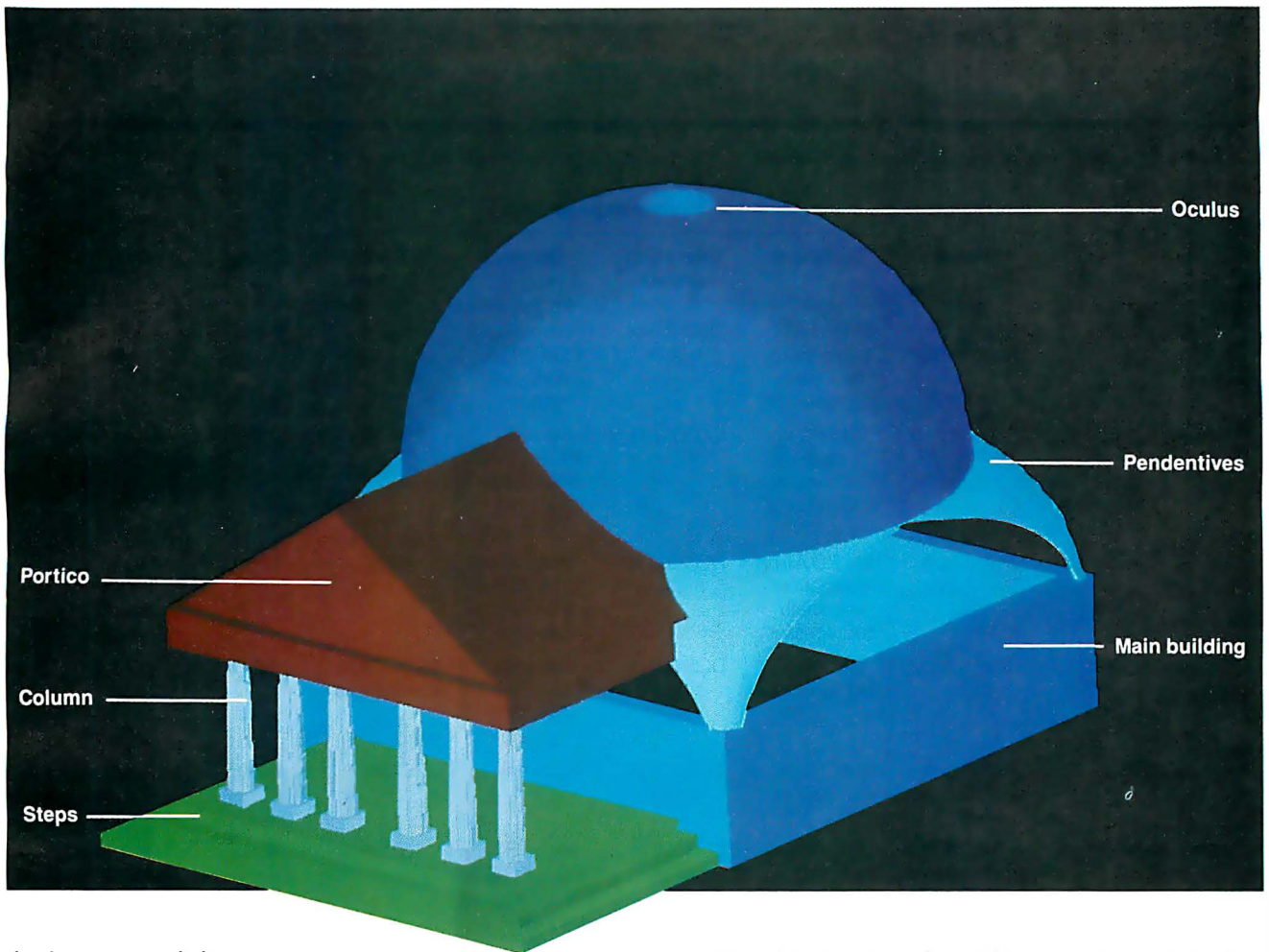

dors' recommended procedures to ensure that we saw each program perform to the best of its abilities.

Not every package can model the pantheon as specified, but the completeness of the exercise wasn't our only goal. Rather, we wanted to explore a variety of 3-D modeling features and to investigate differences in their implementations.

Managing Model Space

In 2-D CAD programs, you work in a single plane inhabited by points, lines, curves, and polygons. Three-dimensional CAD is an infinity of such planes through which 2-D primitives can extrude or revolve, producing rectilinear and curvilinear entities that have length, width, and height. It's not so obvious how to map those planes to 2-D I/O devices. Controlling the 3-D orientation of a model is a difficult task, one that these packages approach in a variety of ways.

A *view* is an image of the model. A *construction plane*—where you construct the 2-D primitives that become 3-D entities—may or may not correspond to a view. When the view and construction plane end up coinciding, 3-D modeling looks a great deal like 2-D drafting does.

For example, we often set up a plan (top) view to create the rectangles that

extrude to become the steps of the pantheon, and an elevation (front or side) view to draw the half-outline of a column. That way, we could snap to points and measure distances on a 2-D grid. However, that 2-D grid needs a depth (or elevation) or z-coordinate that anchors it somewhere on the axis perpendicular to the screen.

The construction plane is first set to zero elevation. But before you draw the next step, you might want to raise it to an elevation of 1 foot. And to draw the outline of the first (leftmost) column, you could establish a plane that's 8 feet deep with respect to a front elevation view.

In some systems, you can move the origin of the construction plane to any 3-D location. Others work with a depth variable that you set to do the same thing. Still others use a 3-D cursor (a mouse- or keyboard-driven 2-D cursor that has an adjustable z-coordinate for raising and lowering the construction plane). Of course, most systems don't require that you move the construction plane in order to draw at a new elevation. You can also typically establish one point at the new elevation by entering its absolute coordinates and then specify remaining points relative to it.

The view and the construction plane

can also differ. That's useful when you're making a 3-D entity from 2-D primitives that lie in different planes. For example, we normally chose an isometric view unrelated to the current construction plane in order to select the arcs that defined a surface patch for the pendentives. That makes it possible to see and point to arcs in the xy , xz , and yz planes all at once. Such a view requires the ability to rotate a model about the x , y , and z axes to any desired orientation or, equivalently, to move a *camera* or *viewpoint* around the model. All the systems do one or the other.

Views tend to proliferate as you build a model, and it helps to have tools that can manage them effectively. With AutoCAD, DataCAD, MaxxiCAD, MicroStation PC, and VersaCAD Design, you can save and recall named views. AutoCAD, MicroStation PC, and VersaCAD Design can list the names; DataCAD and MaxxiCAD let you select names from menus. CADKEY, Mega Model, and ModelMate Plus store views by number only and don't provide menus of views.

These 3-D CAD packages retain the layering and coloring techniques popularized in 2-D counterparts. With 3-D, these techniques are even more useful. Complex geometry can quickly turn into

continued

3-D MODELERS

Table 1: A summary of the CAD packages' features (N/A = not applicable).

| | Format | System requirements | | | RAM (bytes) | Price | Options |
|-------------------------|---------------------------------|---|-------------------|-------------------------------------|-------------------------|--------|--|
| | | Computer | Operating system | Display | | | |
| AutoCAD 10 | 4 5/4" or 3 1/2" floppy disks | IBM PC XT or compatible with math coprocessor | DOS 2.0 or higher | Hercules, CGA, EGA, VGA, and upward | 640K | \$3000 | AutoShade (\$500), AutoCAD AEC (\$1000) |
| CADKEY 3.12 | 16 5/4" or 10 3/2" floppy disks | IBM PC or compatible with math coprocessor | DOS 2.0 or higher | Hercules, CGA, EGA, VGA, and upward | 640K | \$3195 | Advanced IGES Translator (\$1995), CADKEY Solids (\$995) |
| DataCAD with DC Modeler | 5 5/4" or 9 3/2" floppy disks | IBM PC AT or compatible with math coprocessor | DOS 3.0 or higher | Hercules, CGA, EGA, VGA, and upward | 640K | \$3990 | DataCAD Velocity (\$2000) |
| DesignCAD 3D 2.0 | 6 5/4" floppy disks | IBM PC or compatible | DOS 2.0 or higher | Hercules, CGA, EGA, VGA, and upward | 512K (640K recommended) | \$399 | N/A |
| MaxxiCAD 1.02 | 7 5/4" or 4 3/2" floppy disks | IBM PC or compatible | DOS 2.0 or higher | EGA only | 640K | \$1895 | N/A |
| Mega Model | 3 5/4" or 1 3/2" floppy disks | IBM PC or compatible with math coprocessor | DOS 2.0 or higher | Hercules, CGA, EGA, VGA, and upward | 512K | \$995 | Mega Shade (\$395), Mega Draw (\$195), Mega List (\$295) |
| MicroStation PC 3.0 | 10 5/4" floppy disks | IBM PC AT or compatible with math coprocessor | DOS 3.0 or higher | Hercules, CGA, EGA, VGA, and upward | 640K | \$3300 | MicroCSL Customer Support Libraries (\$1000) |
| ModelMate Plus 2.8 | 18 5/4" floppy disks | IBM PC XT or compatible | DOS 2.1 or higher | Hercules, CGA, EGA, VGA, and upward | 512K (640K recommended) | \$1495 | N/A |
| VersaCAD Design 5.4 | 7 5/4" floppy disks | IBM PC XT or compatible with math coprocessor | DOS 2.1 or higher | Hercules, CGA, EGA, VGA, and upward | 640K | \$2995 | N/A |

an indecipherable tangle of lines, so it's necessary to be able to distinguish components and to view them selectively. To create such geometry, it's often necessary to put up temporary scaffoldings; these should occupy scratch layers so that you can easily remove them. And as you add 3-D entities to a model, it takes longer to redraw it, so you can often speed things up by inactivating layers that you don't need at the moment.

3-D Entities

Entities are points and their derivatives: lines, multisegment lines, arcs, splines, surfaces, and, in some cases, solids. En-

tities can look identical but consist of different primitives. For example, a wireframe cube can be 12 individual lines, a single rectangle with a thickness attribute, or a true six-sided box. These look-alikes behave differently. You can't remove one of the faces of an extruded rectangle, for example, as you can with a six-sided box. To distinguish look-alikes, it's useful for entities to be able to reveal their types. Commands that perform this function include AutoCAD's LIST, CADKEY's VERIFY, DataCAD's IDENTIFY, DesignCAD 3D's ID, MicroStation PC's ANALYZE, and VersaCAD Design's EXAMINE.

With surface patches, you can model curved shapes like automobile fenders and propeller blades. A surface patch is to the curves that define it what a spline is to its defining points: a smooth spatial interpolation governed by a set of constraints. With AutoCAD, CADKEY, DesignCAD 3D, and ModelMate Plus, you can apply a surface patch directly to four boundary curves. DataCAD and Mega Model offer a more limited facility. First, you create a patch, and then you attach it point by point to a skeleton of arcs.

The elements that compose repetitive

continued

DRAFIX CAD ULTRA™ FINALLY FILLS AN IMPORTANT GAP IN LOW-COST CAD.



CADAPULT™ YOUR DRAWING INTO LOTUS 1-2-3 OR DBASE.

Drafrix introduces CAD for the real world. Any CAD package lets you create drawings. New Drafrix CAD Ultra with CADapult is the first inexpensive CAD software that can turn your drawings into usable database and spreadsheet information.

First, you can give every element in your drawing specific attributes—a name, a part number, a price, for example. Then, with little more than a push of a button, you can convert the data into a spreadsheet, move it into a database or insert it into your drawing.

Suddenly your concept becomes a bill of materials, a component pricing list, an order form, a job estimate.

"SIMPLE TO LEARN AND EXTREMELY EASY TO USE."

—PC Week

You'll never find an easier CAD software to use. With Drafrix all of the menus are on the screen all of the time—there's nothing to memorize! In minutes you'll create sketches and drawings naturally and effortlessly—drawings that would require weeks of training on other CAD systems.

AMAZING POWER AND SOPHISTICATION FOR ONLY \$395.

All of the drawing, designing and editing functions

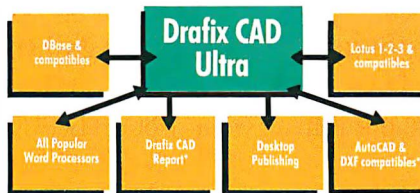

demanded by architects, engineers, drafters, contractors and other serious CAD users are included.

- Create your own symbol libraries with attributes or use our pre-attributed, predrawn symbols supplied with the package.
 - Draw lines, arcs, polygons, splines and bezier curves or freehand sketch.
 - Access our full complement of item and grid snaps for superior accuracy.
 - Use our powerful and flexible automatic dimensioning system and crosshatching and solid fill for complex drawings.
 - Take advantage of function key macros for even greater performance.
 - Use the revolutionary word processing window for adding and editing text in drawings.
- Plus much, much more

EVERYTHING YOU NEED IN A SINGLE PACKAGE.

Other low-cost packages require expensive add-on modules. There's nothing missing from Drafrix CAD Ultra. For no extra cost you get:

- DotPlotter™ for high resolution Dot and Laser Printer output.
- General Symbols Library of 450 pre-drawn objects.
- CADapult exchange utility.
- HPGL compatibility with desktop publishing programs and a full range of pen plotters.

CALL US TODAY.

For the name of your nearest Drafrix dealer, call us today at 1-800-231-8574.

Ask about Drafrix 3D Modeler and Drafrix CAD Report too!



FORESIGHT RESOURCES CORP.
10725 Ambassador Dr.
Kansas City, MO 64153
816-891-1040

Circle 105 on Reader Service Card (DEALERS: 106)

entities like the columns should belong to an aggregate that you can manipulate as a single entity and store for later use in other models. Such aggregations are variously called symbols, blocks, patterns, groups, and cells. DataCAD has a good scheme for managing symbols. It stores them in libraries and can display the contents of a library iconically; to retrieve copies of the column, you simply point to its icon. But all the systems support some sort of aggregation.

Hidden-line removal is the most basic visualization tool. It serves two basic purposes: During the construction of a model, it helps make geometry legible; it's also one way to present a finished model. Nearly all the packages include an integrated hide utility. Shading—the painting of the polygonal surfaces of a model—yields a more sophisticated presentation. DesignCAD 3D, MicroStation PC, and ModelMate Plus have integrated shaders; most of the other packages provide the tool as an option. All the packages give you some way to create a walk-through or slide show made from a series of images of your model.

CAD users are mechanical designers,

urban planners, architects, furniture makers—anyone who must precisely document physical structures. Because they're used in so many different ways, CAD programs have traditionally been organized as extensible toolkits complete with their own built-in programming languages. That extensibility becomes even more critical with 3-D CAD. All the packages except DesignCAD 3D, MaxxiCAD, and Mega Model provide full-fledged programming languages.

Building a spiral staircase, for example, takes a fair amount of work in all the programs. Ideally, you'll want to capture that work in a script that you can reuse. But more important, with a true programming language, you can vary the

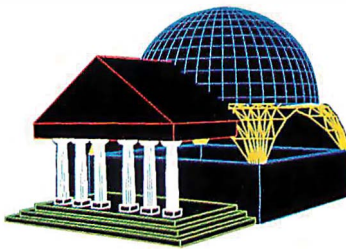

elements of the staircase—the width, depth, number of treads, and so on—and thereby automate the construction of an entire family of related objects. Because most designers work variations on themes, the ability to set parameters for standard elements is essential.

We tested the packages on a Compaq Deskpro 386/20 with 4 megabytes of LIM/EMS memory and a VGA display. In the following sections, we describe our experiences building the pantheon with each package.

AutoCAD 10

Release 10 of AutoCAD is a comprehensive 3-D surface-modeling toolkit. You can specify point locations manually using absolute or relative polar or Cartesian coordinates, or you can do so automatically by snapping the 2-D cursor to grid points or to vertices, intersections, midpoints, perpendiculars, or tangents of 3-D entities. There are many ways to reorient the plane in which the 2-D cursor moves: You can translate its origin along the x , y , and z axes of an existing plane, rotate it about any of its axes, align it to any view, or align it to any plane in

Every copier company talks We're doing something about

Choosing a new copier isn't easy. You look at copiers, you listen to promises. It all gets very confusing.

Now, you don't have to listen to a lot of talk about promises. You can read ours. Because we put it in writing. If you try to compare it to other copier guarantees, you'll find there's no comparison. Suddenly, a difficult decision becomes a very easy choice to make.

Look at the certificate above. Nobody offers you as good a copier guarantee as Harris/3M. So, while

copier salespeople are all giving you a lot of talk, ours will give you something great to read.

Send in the coupon. Or give us a call at 1-800-TLC-COPY. (In Canada, 1-519-668-2230.) We'll send you our 8-page *Consumer Guide to Copiers*. Then, we can talk about it.



Harris/3M copiers have features for all sizes of offices. That includes the 6070. Seventy copies a minute, guaranteed.

your model on which you can identify three points.

All the basic entities—lines, curves, and polygons—are defined by 3-D points. Thus, you can have any orientation in space. In AutoCAD, you extrude planar entities by modifying their thickness and elevation. To model the steps, for example, you can draw rectangular polygons on construction planes at 0-, 1-, and 2-foot elevations and then select them and change their thicknesses to 1 foot. Or you can draw all three rectangles in world space—the original zero-elevation construction plane—and then selectively modify both the thickness and elevation of each. There are many ways to select entities. In any view, you can refer to the last entity created, point to an entity, or use a window to select it.

AutoCAD can create a surface of revolution based on a line, polyline, arc, or spline. For the pantheon's columns, we specified 25 flutes (rotational divisions), 11 vertical divisions for the main part of the column, and nine vertical divisions for the capital. AutoCAD handled all these details easily; it lets you control the number of rotational and longitudinal

faces in a surface of revolution.

Creating the arcs that define the pendentives was trickier. In such situations, it's often easier to enter the arc control points manually than it is to establish each construction plane and then draw with the cursor. Sadly, AutoCAD won't let you do that for arcs, so we had to establish separate *xy*, *xz*, and *yz* planes.

Once we did all that, the rest went smoothly. In an isometric view, we pointed to the four boundary entities—a 90-degree arc along the base of the dome, a right-angled polyline on top of a corner of the main building, and two vertical arcs joined to the endpoints of the arc and the polyline—and used the EDGESURF command to form a meshed surface.

AutoCAD's UNDO command is one of its strongest assets. Most of the systems can reverse the effects of one or more operations that create points, generate entities from points, and delete entities. AutoCAD does that and can also undo operations that copy, move, extrude, and revolve entities. Moreover, it can undo commands that change the orientation of a view, construction plane, or viewport configuration. Since 3-D mod-

eling is tricky, a powerful UNDO command can make life much easier.

Like many of the programs, AutoCAD includes a programming language—called AutoLisp—that you can use to automate repetitive drafting and modeling operations. AutoCAD's command line is unique in that it interprets statements in that language. If you type (+ 2 2), AutoCAD answers with 4; if you type (command "line" '(0 0 0) '(0 0 1) ""), then AutoCAD will draw a line from the origin to a point one unit along the z-axis. That easy interaction between AutoLisp and AutoCAD simplifies the development of AutoCAD extensions.

CADKEY 3.12

Favored by mechanical engineers, CADKEY is nonetheless a general-purpose package with all the tools we needed to model the pantheon (see photo 1). Some conveniences, like multiple viewports and integrated hidden-line removal, are missing. But CADKEY has some powerful features that aren't found in the other wire-frame-and-surface packages.

Excluding the solid modelers, CAD-
continued

about customer satisfaction.

it.



Yes, I'd like to know more about Harris/3M copiers and the Harris/3M Copier Promise.
Send to Harris/3M, P.O. Box 785, Dayton, OH 45401

NAME _____
 COMPANY NAME _____
 ADDRESS _____
 CITY _____ STATE _____ ZIP _____
 PHONE # () _____

____ I'd also like information on your fax machines. MH589

HARRIS/3M

Offer is valid for a limited time and other restrictions and limitations apply; see your Harris/3M sales representative for details. ©1988 Harris/3M Document Products, Inc. Harris is a trademark of the Harris Corporation. 3M is a trademark of the 3M Company.

KEY did the best job slicing a cap from the top of the dome to create the oculus, because it can use a plane to section, or break, line entities. CADKEY also has an impressive set of masking tools (as does VersaCAD Design). You can, for example, create masks that help you to select all the points in the active layer, all entities that aren't circles, or all entities drawn in red.

Surfaces of revolution work well in CADKEY, although we couldn't easily get the columns to look like a stack of foot-high components. That's because CADKEY lets you control the number of rotational divisions but not the number of vertical segments. It also has an assortment of techniques for establishing a construction plane.

A particularly useful technique is the view/depth method. We used it to set a construction plane for drawing the outline of a column. First, we plotted a point at the column's center as seen in the plan view; then, we switched to an elevation view and used that point to anchor the construction plane at the correct depth.

CADKEY supports manual entry of points using polar or Cartesian coordinates. Its on-line calculator makes that task easier because you can store point coordinates in variables, do arithmetic on them, and then feed the results to CADKEY's x-, y-, and z-prompts (AutoCAD also has this capability).

View management isn't too convenient. The system controls views by number and offers eight standard views; you can define views 9 and above for your own use. You define a view by rotating the model about its axes. Each time you do so, CADKEY creates a new numbered view. We didn't realize this until we suddenly discovered that we had created 26 views. The problem is that there's no way to see and manipulate an annotated list of views. If you don't track them manually, things can become confusing.

CADKEY's rendering tools aren't part of the basic modeling package. A separate tool, Solids Synthesis, comes bundled with CADKEY. You can use it to create hidden-line and shaded views of a model. To use Solids Synthesis, you export your model to a CADL file. CADL is both a file transfer protocol and CADKEY's extension language.

Separately, in CADKEY, you execute a CADL macro that lets you take a series of snapshots of your model. Here, you specify the kind of rendering (hidden-line removal or shading) that you ultimately want. The macro writes an animation script that, along with the CADL description of your model, serves as in-

put to Solids Synthesis. You then exit CADKEY and run Solids Synthesis, which reports the mass properties of the entities in the model, generates the rendered views in a new CADL file, and then quits. Finally, you reenter CADKEY and execute the CADL file that

contains the renderings.

CADKEY displays the rendered frames in sequence. We found the process to be cumbersome, but to be fair, we hadn't anticipated exporting the geometry while we were constructing it, which is what you should do.

Photo 1:
A CADKEY image produced on a Mitsubishi 19-inch monitor; the adapter was an Imagraph Image Plus with 256 colors and 1280-by-1024-pixel resolution.

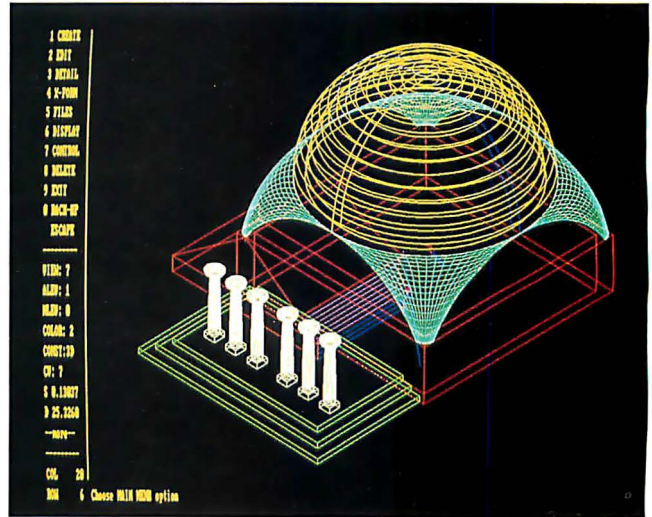

Photo 2:
A DesignCAD 3D image shown on a Mitsubishi DiamondScan monitor; the adapter was an ExtraEM with 256 colors and 640-by-480-pixel resolution.

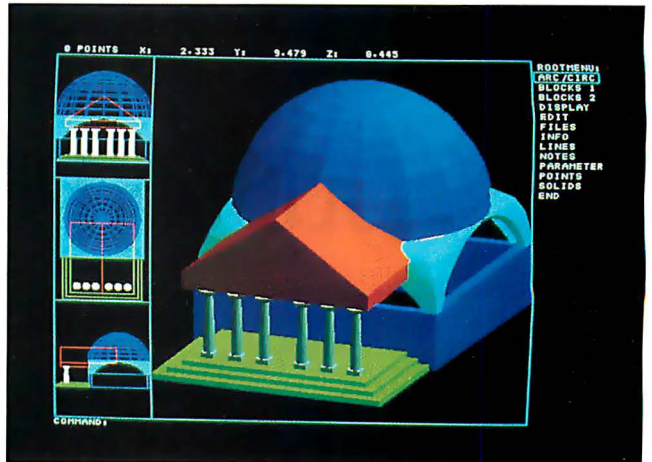

Photo 3:
A Mega Model image produced on an IBM 8514 monitor and 8514/A adapter with 256 colors and 1024-by-768-pixel resolution.



We succeeded in rendering simple entities, but because Solids Synthesis is picky about the geometry you ask it to analyze (e.g., every entity must help to define a closed surface), we bogged down trying to create a pantheon rendering.

DataCAD

DataCAD's focus is the Architectural and Engineering Construction market. The basic package comes with an AEC macro package (written in DataCAD's extension language, DCAL) that automates the modeling of residential and

commercial buildings. By using these macros, which are integrated with the program's menu system, you can quickly place walls, stairs, elevators, plumbing, and furniture in a 3-D model of a building. Hidden-line removal is built into the program. DataCAD Velocity is an optional rendering tool.

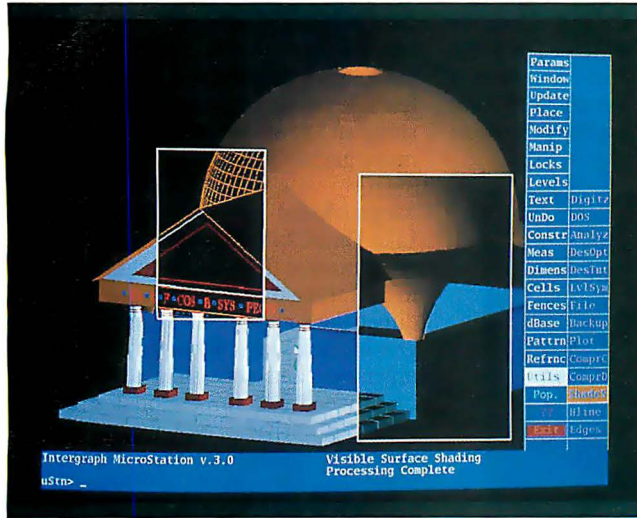

Photo 4:
A MicroStation PC image on an Intergraph 19-inch monitor with a Matrox board.

DataCAD supports surfaces of revolution and can do surface patches, but these features—not typically required for AEC applications—are not as comprehensive or as easy to use as they are in some programs. You can draw splines but can't revolve them, so we built the columns from an arc and a polyline. We didn't succeed in modeling the pendentives, although in principle you should be able to do so by creating a 16-point surface patch and then maneuvering those points into position along the defining arcs.

DataCAD can store layer and color information on a per-view basis, as can MicroStation PC. This feature can be confusing at first. But once you understand what's happening, it provides powerful control over the display of the model. You can't see multiple views concurrently, but it's easy to rotate the model to create a desired view. You can then name it, place it on the menu of views, and select it. In addition, you can use three points to define a construction plane oriented anywhere in space. Keys on the numeric pad make the zoom and pan functions accessible and simple to use. The system supports polar and Cartesian coordinates. You can enter units in feet and inches, although the syntax is unusual: 14.4.1/2 means 14 feet and 4 1/2 inches.

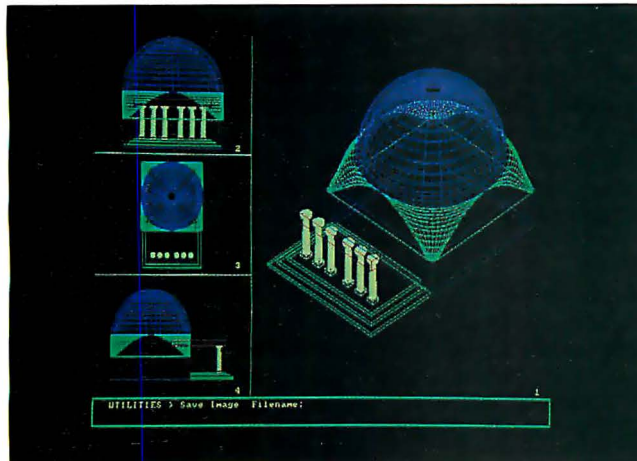

Photo 5:
A ModelMate Plus image produced on a Turbo PGA adapter with 256 colors and 640-by-480-pixel resolution.

DataCAD's walk-through facility is particularly well done. You establish camera and target locations in plan view and then use commands like WALK FORWARD, TURN LEFT, and LOOK UP to move through the model; after each step, you can adjust the incremental distances and angles. Macros written in DCAL, a Pascal-like programming language, provide additional capabilities for managing views. You can create a slide show that presents a series of live (i.e., modifiable) views, animate the views established during a walk-through, and loop through all your named views.

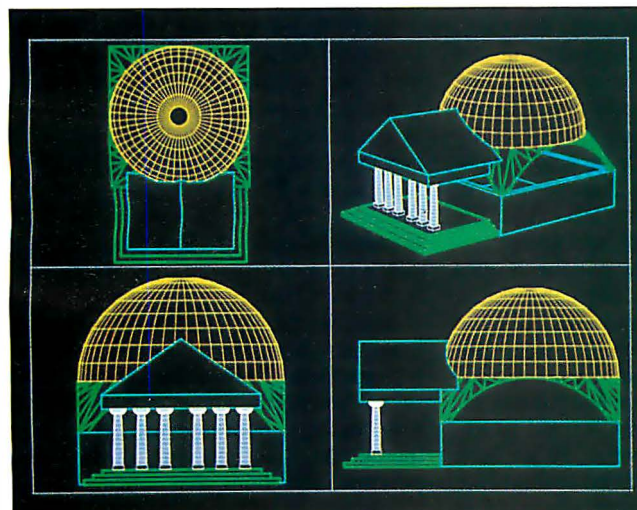

Photo 6:
A VersaCAD Design shade file transferred directly to film using a Hewlett-Packard 7510 film recorder.

DesignCAD 3D 2.0

At \$399, DesignCAD 3D was the least expensive package we saw, yet it was one of the more powerful. The program has a complete set of surface-modeling tools. It can also create primitive solids like boxes and cylinders and can convert

continued

more complex wire-frame entities into solids. In either case, you can perform Boolean operations on the resulting solids. There are many ways to get things done: menus, a command line, and a mouse- and keyboard-driven 3-D cursor. Photo 2 shows DesignCAD 3D's finished rendering of the pantheon.

DesignCAD 3D's organization is unique. In most systems, you invoke a command (e.g., to draw an arc) and then place the defining points; typically, you see the arc drag or stretch to the desired shape. In DesignCAD 3D, you set the points first and then invoke the command. That may seem backward at first, but the method can be effective.

The points define everything in a model, so they have to be set correctly. When you're trying to anchor points to locations in 3-D space, you can often make mistakes—snapping to the wrong entity or specifying the wrong coordinate. In some packages, those mistakes leave debris on the screen that you must clean up before proceeding.

With DesignCAD 3D, you just undo one or more points and keep trying to reset them until you've got the right ones. That discipline can result in efficient use of the drawing commands. This style might not appeal to everyone, though. One thing you can't do, for example, is put an entity somewhere and then drag it to a new location; in some ways, therefore, the procedure is less flexible than the usual one.

But the points-first method does yield some interesting economies with respect to basic drafting. To draw the vertically oriented arcs for the pendentives, for example, we typically drew a three-point arc aligned with the front and one side face of the building, and then trimmed it in half. To do that in most systems, you draw a temporary line intersecting the arc's midpoint, select that line as a trimming tool, select the arc as the entity to be trimmed, invoke the trim command, point to the part of the arc you want to retain, and delete the temporary line. In DesignCAD 3D, you set two points—one at the endpoint of the part of the arc you want to remove and one at the midpoint. Then you issue a POINT MOVE command, and you're done.

We also found the EXTRUDE VARYING command intriguing. To model the 2-foot-thick walls of the pantheon's base, we drew a rectangle representing the bottom of the inner wall, followed by two points at the center of that rectangle and two more 11 feet above that. We then invoked EXTRUDE VARYING and associated scale factors with those points

so that the rectangle extruded up to form the inner wall, out 2 feet for the top surface, down 11 feet for the outer wall, and in 2 feet for the bottom surface.

Most entities aren't automatically solids, but they can be converted to solids if need be. We modeled a 2-foot-thick dome using surfaces and used SOLID SET to convert it to a solid. Then we created a cylinder—which is a solid primitive, so it requires no conversion—and subtracted it from the dome to form the oculus. We could have done the same

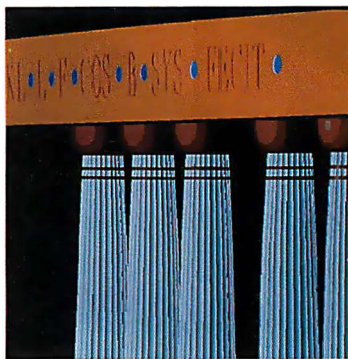

kind of thing with the pendentives—joining exterior and interior surface patches, converting that and the portico to solids, and trimming—but we didn't, since the HIDE and SHADE commands gave good results using just an exterior surface.

MaxxiCAD 1.02

The least powerful of the systems reviewed, MaxxiCAD is nonetheless an attractive product. It features telescoping menus that display the path you've taken to each subcommand. And there's a palette of icon-based tools for controlling layers, colors, and line styles. You can dynamically resize and even overlap viewports, and you can rotate the views in them to any desired orientation. All views are active, so you can begin a line in one view and then continue it in another view (MicroStation PC does this, too). There's also a clever help system that uses animation to illustrate how to use the drawing commands. And the package has a good masking facility.

Still, modeling the pantheon was somewhat cumbersome. Since the system doesn't support polylines, we built the steps from individual line segments. But because MaxxiCAD can't treat a rectangle as a single entity, we had trouble selecting the rectangles we wanted to extrude. Splines can't revolve, so we built the column with an arc and several line segments. MaxxiCAD supports surfaces

of revolution, but with fewer rotational divisions than the 25 we'd specified. When we saved the first column as a block, and then recalled a copy, it came back sans rotational surfaces. These can't currently be part of a saved block, so we ended up just copying the column.

Surface patches aren't supported, although MaxxiCAD did a nice job of plotting points on the pendentives' arc skeleton and, in an isometric view, snapping triangles to those points. The system felt sluggish, however, and the HIDE command garbled the image.

Mega Model

Like DataCAD, Mega Model targets the AEC market. It's strictly a modeler used to prototype 3-D designs; you can't add dimensions and produce finished orthographic drawings. The program is well organized and accessible to beginners. It's divided into three modules: one for creating entities, one for modifying them, and one for viewing them. Switching among the modules is relatively painless, but you do have to invoke a redraw in order to redisplay some derived surfaces, like domes.

In create mode, the system presents two views. One contains the construction plane. It defaults to the xy plane, but you can easily reorient to the xz or yz plane. The other displays a perspective view, which serves as a useful reference. In modify mode, the system defaults to four active views—front, top, side, and perspective—but you can fill the screen with any one of these for detailed work.

The view mode presents a plan view, which you use to move the camera and target, and a perspective view that shows the results. When you establish a new perspective, it automatically becomes the perspective view Mega Model uses in the create and modify modes.

Mega Model doesn't support relative Cartesian coordinates and has no convenient way to establish a nonrectilinear construction plane. You can rotate parts of the model, or the whole model, about any axis, but you can't align a construction plane with an existing entity (e.g., the sloping roof of the portico). You can manually enter x -, y -, and z -coordinates, however, so we had no trouble roughing in the rectilinear parts of the pantheon.

The complex surfaces were more challenging. Mega Model doesn't support true surfaces of revolution (Mega CADD says that a forthcoming release will). It also doesn't support splines. So we drew the column's outline with an arc and a polyline. Revolving that defeated us, so

continued

NOW YOU CAN DESIGN JUST ABOUT ANYTHING... INCLUDING YOUR OWN CADD SYSTEM!

MAGAZINE EDITORS CHOICE CADD 3.0



Anyone can produce a computer-aided drafting and design package that sells for thousands of dollars. But creating one that's fast, powerful, and affordable takes real ingenuity.

That's exactly what we've done at Generic Software™. We sell the most widely used CADD program in the world for under \$500.

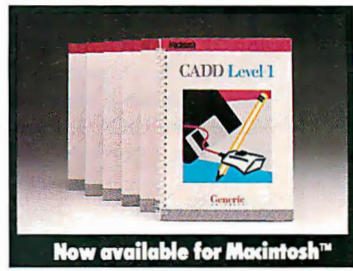

PC Magazine ranked it "Editors Choice" in a face off with 17 low-cost CADD packages. "This product is an outstanding value from every point of view and is highly recommended." "A paperback version of AutoCAD", stated PC Week.

And our CADD programs are just part of what we offer. You can start with Generic CADD Level 1™, then advance to other levels as your needs—and skills—expand.

And you can use our CADD add-ons, Utilities, and symbols libraries to design the CADD system that fits your needs.

You only pay for the functionality you need, and the functionality you get has depth.

Critic tested, market approved. Generic Software offers price, quality, and support. Match our customer support against anyone!

- Unconditional 60-day guarantee on most products
- Unlimited free technical support
- Free monthly newspaper
- Regular updates at modest prices. All adding up to prove that the only thing generic about us is the price.

Call us for a free CADDalog™ or for the name of your local dealer: 1-800-228-3601.

© Generic Software Inc., Level 1 and Generic CADD are trademarks of Generic Software Inc., 11911 North Creek Parkway South, Bothell, WA 98011. Macintosh is a trademark of Apple Computer Inc.

Generic
SOFTWARE

On the Horizon

We looked at three packages that should be available by the time you read this: SilverScreen from Schroff Development, FastCAD 3D from Evolution Computing, and CADVance from IsiCAD. Each looks promising; here's a preview.

SilverScreen

This package makes solids come alive. Schroff Development's rendition of the BYTE pantheon was a tour de force of solid modeling. Everything in the model was a true solid. The pendentives were built by first sweeping a circle at the base of the dome down to join the outer top surface of the building. That, along with the dome itself, served as a tool for trimming the portico. Then the inner base of the dome was swept down to the inner top face of the building to define another solid; subtracting that from the first left an apron-like 2-foot-thick wall supporting the dome. That was halved and then halved again, and arcs that extruded along two axes formed templates that were used to tunnel out the arches. The resulting entity was copied radially to complete the pendentives. All the solid manipulation and the rendering that followed took place with remarkable speed.

SilverScreen manages entities in an innovative way; it uses an object-oriented database and, instead of layers, a tree-structured system. Entities have path names, just as Unix and DOS files do. Moreover, each has its own *entity space* (an imprint of the construction space that was in effect when the entity was created) and axes of rotation. So you can rotate an entity about its own axes at any time; you don't have to first align it with construction space.

Further, a child object inherits the orientation of its parent. For example, if you model a robot arm so that the root object contains an arm that in turn contains a hand, you can move the hand along with the arm and then rotate the hand about its own axis.

SilverScreen supports multiple viewports and can display different models concurrently in separate viewports—a unique feature. A 3-D cursor operates in all views, in a construction space that you can orient by means of a rich variety of techniques. SilverScreen can place patterns on surfaces and display those

patterns with perspective. The program comes with built-in hidden-line removal and shading; the shader can optionally show the edges at the intersection of solids.

Extensibility was clearly a major consideration in the design of SilverScreen. The script language is syntactically equivalent to the menu-driven command system, and you can automatically generate scripts by recording sequences of modeling commands. There are also two full-fledged languages—one based on C, one based on BASIC—that can wield the system's resources in more sophisticated and programmatic ways. SilverScreen is an impressive package. Watch for it.

FastCAD 3D

FastCAD 3D lives up to its name—it's written in assembly language and is very fast indeed. FastCAD 3D can create a hidden-line rendering of the BYTE pantheon in about the time it takes some of the other programs to draw it in wire frame.

Macintosh users will like FastCAD 3D's interface. You access functions by way of pull-down menus and a palette of icons; there's also a command line, which is something we wouldn't want to live without. The program features a rich assortment of tools for moving and resizing windows and for adjusting the views displayed in those windows.

All views are active, although we ran into problems with the beta software when trying to draw interactively with the cursor. Grids and cursor tracking weren't working properly, so it was tough to snap to grid points and measure distances with the cursor. Evolution Computing assured us that these functions will work when it starts to ship the product.

FastCAD 3D provides two schemes for establishing a depth perpendicular to the screen. You can use the Zoom Plane command to slide the construction plane in and out along a given view's z-axis, or you can use Depth Mode to specify depth on a point-by-point basis. In the latter case, you'd draw the column's vertical line by marking its x- and y-coordinates in plan view and indicating its z-coordinate in a front or side elevation view. Both methods work, but they require functional

grids and cursor tracking to be useful. In the meantime, we were able to build the pantheon by keying in absolute and relative coordinates.

FastCAD 3D's dome primitive did everything we wanted in a single command: You can control both the thickness of the dome and the size of an aperture at its top. The surface patch works well, and as a bonus, you can vary the resolution of all the meshes in a model—after they've been created—by adjusting a system variable. Remarkably, FastCAD 3D crammed all the data required to model the pantheon into 5K bytes—significantly smaller than the files other systems produced.

CADVance 3.0

CADVance is missing some features you need to model the pantheon. It doesn't support surfaces of revolution or Coons patches. But its Visual Guidance System interface deserves attention. The VGS displays three grids concurrently, aligned with the xy, xz, and yz planes, and you can lock the cursor to any of these. You can begin a line horizontally in the xy plane—using its grid—and then switch to the xz plane and use its grid to extend the line vertically.

In the midst of a drawing command you can switch planes, and you can even slide a plane in and out along its perpendicular axis. It's a wonderfully intuitive system that makes operating in 3-D space natural and easy. A powerful set of view controls enables you to orient the three interlocking grids any way you like; here, too, you can pause in the middle of a drawing command, make an adjustment, and continue.

Currently, there's an uneasy alliance between CADVance's 2-D and 3-D subsystems. As with VersaCAD Design, you create arcs and curves in the program's 2-D mode and then export them to 3-D mode. Some capabilities not yet natively supported, however, can be simulated with the help of CADVance's extension language; IsiCAD showed us how to make the pantheon's columns and dome that way. The program isn't intended to compete head to head with full-fledged 3-D modelers: It's a drafting tool with 3-D enhancements. Still, those enhancements are impressive; of all the 3-D interfaces we've seen, the VGS was the most comfortable.

we turned to Mega CADD for help. Its procedure entailed modeling a cross section of the column with thickness and then, in plan view, projecting the faces of the section to a point to form a wedge.

Once that was done, we manually rotated and copied the wedge to form a column. That worked for one column, but, due to constraints on how many points the system can manage, we couldn't do all six that way. Instead, Mega CADD recommended another procedure: extruding and scaling the top faces of three cylinders. That's an approximation of the desired shape, but it's the same one that you get by revolving a polyline.

We also had trouble creating the pendentives on our own. Here's the procedure Mega CADD described to us, the results of which appear in photo 3. Begin with a 90-degree arc at the base of the dome and then scale and lower it in several increments to create a frame. In plan view, identify the control points of these arcs and attach triangles to them. Finally, since you can't snap directly to the z-coordinates of the arc control points, switch to elevation view to move the triangles to the correct elevation.

To walk through the pantheon, you mark a series of camera and target locations in plan view; the PLAY command steps through the views you've established. For rendered views of the pantheon, we exported the model to Mega Shade; it's licensed from Control Automation and is functionally equivalent to the rendering tools built into ModelMate Plus.

MicroStation PC 3.0

MicroStation PC is a sophisticated general-purpose package that's attractive to organizations that also use its VAX-based counterpart, IGDS, but that stands alone as a powerful microcomputer-based surface modeler. The package comes with three weighty manuals, and it's not the type of program that you can learn through casual use. But it does everything a surface modeler must do—with class.

MicroStation PC supports multiple active views and can display layers on a per-view basis. The construction plane is governed by a depth variable that's convenient to set. For example, to set the depth for drawing a column outline in front view, you set a point in the top view on the column's center, invoke the ACTIVE DEPTH command, and point to the window containing the front view.

MicroStation PC handled the pantheon's columns nicely. The grid can display major divisions in feet and minor divisions in inches, which makes it easy to

mark off points for the arc in an elevation view. Another useful feature is tentative point-snapping. Pressing both of the mouse buttons simultaneously (we used a Microsoft Mouse) or the middle button on a three-button mouse establishes a tentative point. If it's the correct one, you press the left button to accept it. MicroStation PC's UNDO command can unwind a whole sequence of construction steps, although you can't undo view rotations and zooms as you can in AutoCAD.

Intergraph showed us yet another way

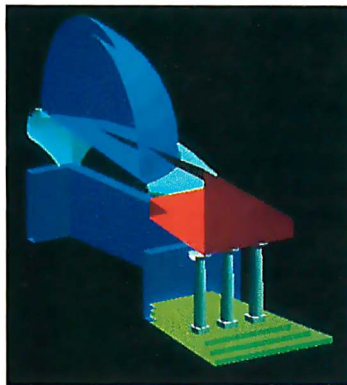

to build the pendentives. First, we established a 90-degree arc at the base of the dome—actually, a *shape* made of two arcs joined at the endpoints—so we could model the dome with thickness. Then we set a point directly above the corner of the building at the same elevation as the base of the dome. With the system's scaling factor set to 0.8 and that point as a reference, we repeatedly executed the PROJECT SURFACE command.

The result was a series of diminishing arc shapes that descended from the base of the dome to the top of the building along a curved path equidistant from the control point. PROJECT SURFACE, which we also used to form the steps, the block at the base of the column, and the walls of the building, joins the surfaces that it projects, creating enclosed solid-looking objects. Given that MicroStation PC doesn't yet support true surface patches, this was a good solution.

MicroStation PC includes integrated hide and shade utilities. We couldn't run the shader because our VGA supported just 16 colors, and we'd have needed 256. But hidden-line removal worked well—it was faster than on most other systems. You can even fence a portion of a model and restrict rendering to just that portion. Photo 4, provided by Intergraph, shows a fully rendered view of the pantheon. Finally, MicroStation PC is

built to take advantage of a network; multiple users working on a large project can share *reference files*. That facilitates interdisciplinary work and avoids duplicate storage of data.

ModelMate Plus 2.8

ModelMate Plus concentrates strictly on 3-D modeling. And like DesignCAD 3D, ModelMate Plus can work with solids. These two packages (and SilverScreen, which is discussed in the text box at left) were the only ones able to represent the dome as a 2-foot-thick solid and then cut the oculus by subtracting a solid cylinder from it (see photo 5).

A version of ModelMate Plus's core program is also available from Generic Software. Generic 3-D Solids is less expensive, but it doesn't include ModelMate Plus's modules for Boolean operations, mass properties analysis, and file conversion. If you add these optional modules to 3-D Solids, the package costs a bit more than ModelMate Plus.

ModelMate Plus's interface isn't as smooth or consistent as DesignCAD 3D's, but it got the job done. A construction plane, which you can display as a rectangular icon, guides the placement of most entities. When you add an entity, its 3-D center is initially at the origin of that plane (i.e., at the center of the rectangular icon). This can be disconcerting. For example, when we added a box to create the first step, we expected that it would materialize on top of the construction plane. In fact, it appeared 6 inches lower, so that in elevation view the plane was halfway between the step's top and bottom faces.

It was simple to move the step up 6 inches. But, in general, this method requires that you halve all *x*-, *y*-, and *z*-dimensions in order to orient the construction plane correctly. Control Automation plans to change this in a future release; according to the company, a significant rewrite of ModelMate Plus's interface was in the works as of this writing.

ModelMate Plus's 3-D cursor is both its most powerful and most confusing feature. Unlike the other packages, this one doesn't present a cursor when you boot the system. Only when you ask the system to add an entity can you invoke the cursor, by pressing the space bar. It's both a mouse- and keyboard-driven cursor and a menu of subcommands that you use to snap to locations, enter absolute coordinates, and draw splines and arcs. We thought that this made ModelMate Plus difficult to explore and to learn.

After getting the hang of the system,

continued

COMPANY INFORMATION

American Small Business Computers, Inc.

(DesignCAD 3D)
327 South Mill St.
Pryor, OK 74361
(918) 825-4844
Inquiry 1045.

Autodesk, Inc.

(AutoCAD)
2320 Marinship Way
Sausalito, CA 94965
(415) 332-2344
Inquiry 1046.

CADKEY, Inc.

(CADKEY)
440 Oakland Rd.
Manchester, CT 06040
(203) 647-0220
Inquiry 1047.

Computer Resource Technology Corp.

(MaxxiCAD)
2164 East Broadway
Tempe, AZ 85282
(602) 921-9638
Inquiry 1048.

Control Automation, Inc.

(ModelMate Plus)
P.O. Box 160100
Altamonte Springs, FL 32716
(305) 682-7077
Inquiry 1049.

Evolution Computing

(FastCAD)
437 South 48th St., Suite 106
Tempe, AZ 85281
(602) 967-8633
Inquiry 1050.

Intergraph Corp.

(MicroStation PC)
One Madison Industrial Park
Huntsville, AL 35807
(800) 345-4856
Inquiry 1051.

IsiCAD, Inc.

(CADVance)
1920 West Corporate Way
P.O. Box 61022
Anaheim, CA 92803
(714) 533-8910
Inquiry 1052.

Mega CADD, Inc.

(Mega Model)
65 Marion, Suite 301
Seattle, WA 98104
(800) 223-3175
Inquiry 1053.

Microtecture

(DataCAD)
1224 West Main St., 4th floor
Charlottesville, VA 22903
(804) 295-2600
Inquiry 1054.

Schroff Development

(SilverScreen)
18 Ash Swamp Rd.
Scarborough, ME 04074
(207) 883-3936
Inquiry 1055.

Versacad Corp.

(VersaCAD Design)
2124 Main St.
Huntington Beach, CA 92648
714-960-7720
Inquiry 1056.

we were able to build all the pantheon except the pendentives. And with Control Automation's help, we succeeded in doing that. After establishing the four boundary curves—using the 3-D cursor in an isometric view to snap to locations on a set of reference arcs—we selected the curves and applied the patch.

In ModelMate Plus, the selection of entities, or of polygons within entities, works differently than in most systems. Instead of pointing, you scroll through a list of entities—each is highlighted in turn—until you reach the one you want. You can also select an entity by specifying its numeric handle, but since there's no way to name entities or to annotate a menu of numbers, that's not too useful.

Cutting the oculus in the dome was straightforward. We added a cylinder with a diameter of 6 feet, then used the Boolean utility to subtract it from the dome. It prompted for the numeric handles of the entities involved, forked a separate executable to perform the Boolean operation, and returned us to ModelMate Plus's main menu. When we reloaded the model, the cylinder was gone and the oculus had been formed.

VersaCAD Design 5.4

VersaCAD Design 5.4 did a good job with the pantheon (see photo 6), but we had a hard time figuring out how to construct it. That's partly because VersaCAD Design doesn't integrate 2-D draft-

ing and 3-D modeling—they're two separate modules. Moreover, the 3-D modeler itself is divided into two parts—a Create environment in which you construct the elements of a model, and a Scene environment in which you assemble those elements. To model the pantheon, we used all three modules.

You can create splines only in the 2-D drafting module, so we created the outline of the column there. The surface of revolution command resides only in the Create environment, so we revolved the column's outline and made its components into a block there. Finally, we imported the block into the Scene environment to duplicate the columns and place them on the steps. When moving from one environment to another, we frequently had to reset the color, layer, grid, snap, camera, and target. These aren't global settings in VersaCAD Design—they're module-dependent.

Revolving a column, saving it as a block, and inserting copies of the block took a long time. And screen refreshes took longer than with, say, AutoCAD or CADKEY, despite the fact that VersaCAD Design's triangulated representation of the pendentives used fewer surfaces. A graphics card that supports display list processing (off-CPU vector computation) would have speeded things up. Versacad claims that its system makes efficient use of such coprocessors.

Despite these frustrations, VersaCAD Design impressed us as a powerful 3-D package. We particularly liked its implementation of a 3-D cursor. No matter what the active view, you can move the mouse cursor along the x-, y-, and z-axes of a world coordinate system. Hot keys can anchor the cursor along any one, any two, or all three of the axes. To create an arc at the base of the dome, we locked the x- and y-axes so the cursor could move only along the z-axis, set the z-coordinate to 22', and locked z and unlocked x and y in order to draw the arc's control points.

Because you can move along all three axes and because VersaCAD Design displays all views in perspective, the cursor takes some getting used to. Moving the mouse up, down, left, or right on your desktop translates into quite different movements of the cursor on the screen; initially, it's easy to lose track of the cursor entirely. But the technique is powerful, and with practice, you can operate almost entirely in a perspective view that helps you make sense of the geometry you create.

VersaCAD Design offers another handy navigational aid. In object snap

continued



**Make your
point without
a trace of
doubt.**

**With the new
HIPAD PLUS
series.**

If you've ever used a digitizer, you know that all digitizers are not created equal, or accurate, or even easy to use.

But today there's a new line of digitizers that can deliver the performance, precision, and convenience you need. It's the new HIPAD Plus™ series from Houston Instrument.

Compare, for example, the sleek 9012 and 9018 models which contain HI's exclusive tilt-correction feature. This unique feature lets you use the stylus like a pencil—no need to hold it in an awkward perpendicular position. HI's tablet captures only the points touched by the tip of the stylus, so you can make menu selections, create freehand drawings, move the screen cursor, or edit pixel-by-pixel—without a trace of doubt.

If you prefer a handheld cursor, you'll find HI's new four-button cursor has the same pin-point precision.

With tablet sizes ranging from a compact 12"×12" to a drafting-size 44"×60", each HIPAD Plus digitizer reflects HI's tradition of price/performance excellence.

And industry experts agree:

"The HIPAD Plus tablets offer the best resolution of all the products reviewed, excellent accuracy specifications, and a hassle-free setup routine using a menu template—all at a price lower than those of tablets offering half as much."

BYTE

January 1989
pg. 174

Get the point? For more details, call 1-800-444-3425 or 512-835-0900.



**HOUSTON
INSTRUMENT**

A DIVISION OF **AMETEK**

8500 Cameron Road, Austin, TX 78753

HIPAD Plus and Houston Instrument are trademarks of AMETEK, Inc.

Circle 130 on Reader Service Card

CAD Warehouse, Inc.
8229 E. Washington Street
Chagrin Falls, Ohio 44022

**800
289-1650**

"PAN OVER FOR SUPER PRICES"

**CADD Workstations
featuring EVEREX STEP Series Computers**

Each system fully configured including 2 Serial Ports, 1 Parallel Port, corresponding Math CoProcessor, Enhanced "AT" 101 Keyboard, DOS 3.3, and GW-Basic. Each system thoroughly tested prior to shipment and supplied with a 1-Year "On-Site" Warranty !!!

| EVEREX STEP | CACHE | 40 MB MFM | 80 MB MFM | 160 MB ESDI | 300 MB ESDI |
|--------------|-------|-----------|-----------|-------------|-------------|
| 386/25 w/4MB | 64KB | \$7328 | \$7570 | \$8458 | \$9490 |
| 386/25 w/2MB | 128KB | 5992 | 6273 | 7094 | 8127 |
| 386/20 w/4MB | 64KB | 6079 | 6318 | 7247 | 8273 |
| 386/20 w/2MB | 128KB | 4999 | 5150 | 5961 | 6972 |
| 386/16 w/2MB | 128KB | 4290 | 4532 | 5399 | 6411 |
| 286/20 w/2MB | — | 3487 | 3726 | 4686 | 5615 |
| 286/16 w/2MB | — | 3121 | 3359 | 4287 | 5218 |
| 286/12 w/1MB | — | 2452 | 2687 | — | — |

Monitors & Card Combo's

| Graphics Card with: | Mitsubishi 19" HL6905 | NEC XL Multisync | Hitachi 19" CM2085 | Nanao 16" 9070S | Hitachi 15" HM Series |
|-------------------------|-----------------------|------------------|--------------------|-----------------|-----------------------|
| Artist XJ10 | \$4471 | \$4332 | \$4061 | \$3000 | \$3320 |
| Artist XJ10 w/VGA | 4939 | 4821 | 4524 | 3463 | 3782 |
| Artist 12/256 | 5818 | — | 5393 | — | 4651 |
| Verticom HX-16 w/VGA-16 | 4144 | 4030 | 3737 | 2676 | 2996 |
| Metheus 1104 | 4481 | 4366 | 4072 | 3010 | 3330 |
| Metheus 1128 | 3449 | 3339 | 3050 | 1989 | 2308 |
| VMI-1024/256 | 4160 | 4047 | 3754 | 2693 | 3012 |
| VMI-Cobra/16 | 5269 | 5149 | 4850 | 3789 | 4108 |
| Photon 1000+ | 4679 | 4563 | 4267 | 3206 | 3525 |
| Photon 2048-50 | 3468 | 3358 | 3069 | 2008 | 2327 |
| #9 SGT Plus | 4519 | 4403 | 4108 | 3047 | 3366 |
| Monitor Only | 3969 | 3857 | 3565 | 2504 | 2823 |
| | 2470 | 2350 | 2075 | 1036 | 1345 |

Digitizers

| | |
|---------------------------|--------|
| Calcomp | |
| 12 x 12 4-Button | \$ 345 |
| 12 x 12 16-Button | 345 |
| 12 x 18 4-Button | 732 |
| 36 x 48 16-Button | 3850 |
| Summagraphics | |
| Sketch + 12 x 12 | \$ 345 |
| 12 x 18 | 658 |
| 36 x 48 16-Button | 3889 |
| Kurta | |
| 12 x 12 4-Button | \$ 389 |
| 12 x 17 4-Button | 633 |
| Cordless Puck Add | 33 |
| 36 x 48 16-Button | 3035 |
| Hitachi | |
| Puma 12x12 4 or 12 Button | \$ 399 |
| Tiger 12 x 12 12-Button | 599 |
| 36 x 48 16-Button | 3872 |
| GTCO | |
| 11 x 11 DPC 4-Button | \$ 552 |
| 24 x 36 DPC 4-Button | 2173 |
| 36 x 48 DPC 4-Button | 2669 |

***** CADD BUSTER *****

EVEREX STEP 386/25 with 2MB SIMM, 387-25 Math Coprocessor, 1.2MB Floppy, 80 MB Hard Drive, 2 Serial, 1 Parallel Port, Keyboard, DOS 3.3 and GW-Basic with your choice of either Graphics Card: Artist XJ10 - Dual Verticom HX16 - VGA(8) attached to a Hitachi 19" Multiscan Color Monitor with your choice of digitizer: Calcomp 12 x 12 4-Button/Stylus Calcomp 12 x 12 16-Button SummaSketch Plus and a: Calcomp 1023 Artisan A-D 8 Pen Plotter
*** Fully configured and ready to run *
\$ 14,350.00 -- DELIVERED ***

Plotters

| | |
|----------------------------|--------|
| Calcomp | |
| 1023 Artisan | \$3725 |
| 1043 - GT | 5450 |
| Houston Instruments | |
| DMP - 61 | \$3545 |
| DMP - 62 | 4445 |
| Multi Pen Option | 565 |
| Ioline | |
| 3500 A-D 1 Pen | \$2430 |
| 3700 MP | 3499 |
| 4000 MP | 4422 |
| Roll Feed Option | 148 |
| Hewlett Packard | |
| ALL Models | CALL |

mode, the cursor will move only to the vertices of entities. That, in conjunction with a feature called Big Points that enlarges the vertices, made it easy to attach a network of triangular surfaces to the arcs that define the pendentives.

The Perspective View

The 3-D CAD market is changing on a monthly basis; we've just taken a snapshot of it. The traditional CAD packages all have unique strengths and deserve their solid reputations. AutoCAD is both powerful and forgiving; it offers many ways to get things done, and if you run into trouble, you can always use UNDO and try another approach. CADKEY's 3-D features are well integrated. The program supports one of the richest sets of geometric primitives and tools for selecting, stretching, trimming, and slicing those primitives.

DataCAD is a strong AEC package with full 3-D capability and an especially useful walk-through facility. MicroStation PC's reference files and network support make it an attractive choice for multiuser projects. VersaCAD Design's 3-D cursor works as well as any we've seen. The program is slow on a standard VGA, however. More than most of the other programs, VersaCAD Design requires a graphics adapter with a display list processor.

The modeling packages have unique strengths, too. DesignCAD 3D combines effective modeling with true solid manipulation. Don't be fooled by the remarkably low price; this program can really perform. Both MaxxiCAD and Mega Model offer attractive and well-organized interfaces that make them easy to learn and use. ModelMate Plus can also do solid modeling, and it does mass properties analysis as well.

The story isn't over yet. These 3-D CAD programs initially appeared on low-end hardware in response to the needs of users of traditional 2-D CAD packages. But the migration of 3-D modeling to the microcomputer is attracting new kinds of users, who in turn influence the development of these products. Expect more and better integration of 2-D drafting and 3-D modeling and a strong move toward solid modeling. These are exciting times for CAD, and the best is yet to come. ■

Brad Holtz is president of WBH Associates, a CAD consulting firm in Bethesda, Maryland. You can reach him on BIX c/o "editors." Jon Udell is a BYTE technical editor. He can be reached on BIX as "judell."

The above is a partial listing of our product line. Please inquire if you're interested in a product not listed. Prices subject to change without notice.

- * Shipping limited to Continental U.S.A.
- Quoted prices reflect a 2% cash discount.
- C.O.D., VISA, and Mastercard accepted.
- Rated companies call for terms.
- All manufacturers' warranties apply.

SoftWest™ DAVC...

Manages The Evolution Of Your CAD Ideas.

The evolution of an AutoCAD® drawing often consists of a series of very small changes that add up to some pretty big differences. A line here, a new dimension there, and before you know it, you've got 20 versions of almost the same drawing taking up all of your disk space.

You know from experience that you can't risk deleting any of the earlier versions. What if one of your ideas hits a dead end and you have to retreat a few steps? That's where SoftWest DAVC comes in.

SoftWest DAVC lets you efficiently archive and recall up to 32 (thirty-two) versions of an AutoCAD drawing. It stores a complete copy of the original file, and the differences for each subsequent revision. SoftWest DAVC then uses these differences to quickly reconstruct any version of your drawing.

Using SoftWest DAVC with your AutoCAD system is simply the most cost-effective way to maximize your disk space. SoftWest DAVC can free-up several megabytes of space for a lot less than the cost of adding another disk drive.

You can also instruct SoftWest DAVC to display each individual revision level in a different color making it easy to see and analyze the progression of changes.

Drawing Archive & Version Control 1.0
Copyright © 1989 The Great SoftWestern Company, Inc.

| # | Version | ACAD Version | Color | Archive Date and Time |
|----|---------|--------------|-----------|--------------------------|
| 1 | 1.0 | ACAD Rev 10 | Red | Mon Feb 06 07:44:03 1989 |
| 2 | 1.1 | ACAD Rev 10 | Yellow | Mon Feb 06 07:44:03 1989 |
| 3 | 1.2 | ACAD Rev 10 | Green | Mon Feb 06 07:44:03 1989 |
| 4 | 1.4 | ACAD Rev 10 | Cyan | Mon Feb 06 07:44:42 1989 |
| 5 | 1.5 | ACAD Rev 10 | Blue | Mon Feb 06 07:44:56 1989 |
| 6 | 1.6 | ACAD Rev 10 | Magenta | Mon Feb 06 07:45:08 1989 |
| 7 | 1.7 | ACAD Rev 10 | White | Mon Feb 06 07:45:23 1989 |
| 8 | 1.8 | ACAD Rev 10 | Dark Grey | Mon Feb 06 07:45:36 1989 |
| 9 | 1.9 | ACAD Rev 10 | Dark Red | Mon Feb 06 07:45:51 1989 |
| 10 | 2.0 | ACAD Rev 10 | Brown | Mon Feb 06 07:46:14 1989 |

Input Name: HAWD Compress is OFF
Output Name: HAWD Revised Changes is OFF

Archive Restore Compress New Delete Help Quit
Input Name Output Name Toggle Compress Use Changes

Like all Great SoftWestern products, SoftWest DAVC is available through your authorized AutoCAD dealer. SoftWest DAVC manages the changes so that you can let your ideas evolve — and that's how the fittest survive in the Great SoftWest.

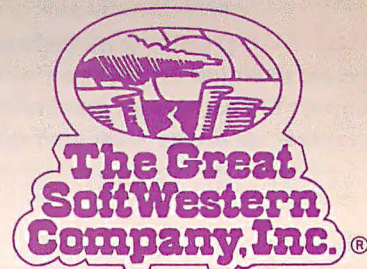

AutoCAD is a registered trademark of Autodesk, Inc.

The Great SoftWestern Company, Inc.,® 207 W. Hickory Street - 202, Denton, Texas 76201
1-800-231-6880 Information & Orders 1-817-383-4434 Technical Assistance

Why VersaCAD?

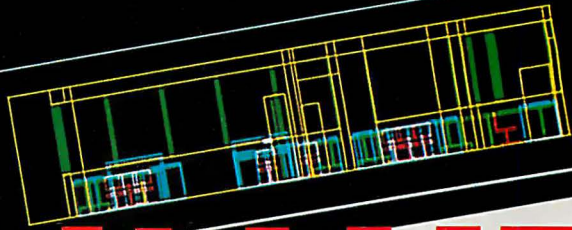
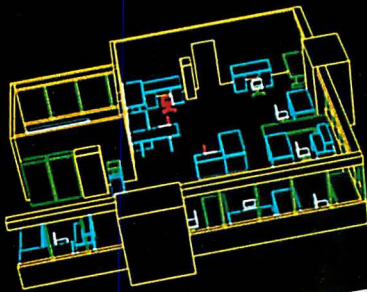

Multiple 3D viewports let you work in up to 16 views at once. Programmable template available for automated architectural design.

VALUE.

- 1. Everything you need.** VersaCAD® DESIGN integrates 2D drafting, true 3D with color shading on any screen, bill of materials and universal translators. No need to buy extra-cost add-ons.
- 2. Aggressive pricing.** VersaCAD value includes affordable site licenses that grow with your company. Quantity discounts. Low-cost upgrades. They stretch your design power, not your budget.
- 3. Total support.** The industry's most respected technical support staff is just a phone call away. You can always get direct help from the experts, no matter what your question.
- 4. Fast productivity.** VersaCAD is consistently ranked the easiest to learn of the full-scale CAD systems. And our CAD programming language works just like BASIC. So you can do it yourself.
- 5. Use all your computers.** VersaCAD runs on MS-DOS, Macintosh and UNIX platforms, with complete drawing transfer. Plus proven 2D/3D IGES and DXF translators, all built into the system.

And every VersaCAD system is backed by the strength of Prime Computer, Inc., one of the two largest CAD companies in the world.

Find out why 60,000 users have committed to VersaCAD value. See your authorized dealer today, or call Customer Service at (714) 960-7720.

"Top Value Rating"
— Infoworld

VERSACAD®
Design
The Total Design Solution

Versacad Corporation, 2124 Main Street, Huntington Beach, CA 92648
A Company of Prime Computer, Inc.

Circle 281 on Reader Service Card



Computing in Hand



▲ Sharp Wizard

Psion
Organiser

Hand-held computers like the Sharp Wizard and the Psion Organiser pack a lot of functionality into a small size

Wayne Rash Jr.

It wasn't that long ago that the first laptop computers were making headlines. But now, things have changed. Much of the functionality of a laptop computer of the past can now fit into a hand-held computer that slips comfortably into a coat pocket.

The Sharp Wizard OZ-7000 seems to have been designed with exactly that purpose in mind. It's almost the same size and weight as a pocket appointment book or Day-Timer. The Psion Organiser II Model XP is a little larger but not much different in functionality. Both hand-held computers resemble calculators more than they do personal computers, but looks aren't everything. They're both full-fledged computers, capable of the same tasks as their larger brethren.

But these machines are not as easy to use as larger computers are. Because they are quite small, so are their key-

boards and screens. Both the Wizard's and the Organiser's keyboards are laid out in an alphabetic, not QWERTY, format. You wouldn't want to use either of them for word processing, but you can use them for other tasks that don't require much typing. And if you do need to use a real keyboard, both machines can be connected to a desktop computer.

These machines are designed for functions that people are likely to need while away from their desks: They keep track of appointments, tell you the time, signal you with alarms, and work as calculators. They also have notepads and places to store addresses. Finally, they both support serial communications so that you can move information between them and your office computer.

The Sharp Wizard OZ-7000

The Wizard is aimed primarily at the users of pocket appointment books or Day-Timers. Unlike a Day-Timer, it beeps at you when you have a meeting, and it triggers an alarm at a set time. Also unlike the Day-Timer, entering the appointment information is awkward. Typing on tiny keys, even for a brief period, just isn't very convenient. The documentation has suggestions for using the user dictionary to enter commonly used words, but it's cumbersome. This is one area where it's hard to beat a pencil and paper for actual functionality.

Most of the standard features of the Wizard are related to time. One button displays your schedule, and another displays a month at a glance. A clock shows your local time, and a world clock tells you the time in any of 200 cities.

The calendar looks good on the Wizard's clear eight-line display. You see the entire month, as well as a line that tells today's date, the day of the year, and the number of days remaining in the year. You can scroll through the months and the days of the month at will, using the arrow keys on the keyboard.

continued

Sharp Wizard OZ-7000

Company

Sharp Electronics Corp.
Sharp Plaza
Mahwah, NJ 07430
(201) 529-8874

Components

Processor: Custom proprietary 8-bit CPU running at 32.768 kHz
Memory: 32K bytes
Mass storage: None
Display: 16-column by 8-row LCD
Keyboard: 73 keys plus touch pad for IC application cards
I/O interfaces: 4-pin option jack; 15-pin option jack
Battery: Two CR-2032 lithium cells (life: 90 continuous hours); one CR-1616 memory backup (life: two years)

Size

Open: $7\frac{7}{32} \times 6\frac{13}{32} \times 1\frac{7}{32}$ inches;
Closed: $3\frac{11}{16} \times 6\frac{13}{32} \times 2\frac{7}{32}$ inches;
8 ounces

Documentation

Owner's manual

Price

\$299

Inquiry 853.

The schedule feature lets you set a meeting for any day. You can also enter two kinds of repeating, anniversary-type dates: absolute dates, such as birthdays, and relative dates, such as a meeting on the second Wednesday of every month. You can set an alarm to let you know when it's time for the meeting, and you can include as much information as you need about the meeting, up to 512 characters. You can scroll past the eight-line limit.

Unfortunately, the Wizard has no word wrap when you type in text; it simply splits a word wherever it falls at the end of the line. The calendar makes up for that by having a nice variety of displays for showing you your scheduled time. The daily display has a slick, Gantt chart-type display that shows you the time and duration of each appointment.

The other three standard functions are the telephone list, the memo pad, and the calculator. The phone list lets you save and recall names and phone numbers. It's a reasonably effective way of storing phone numbers, and you can transfer your list from your PC using the \$179 Wizard PC-Link from Traveling Soft-

Psion Organiser II Model XP

Company

Psion plc.
Psion House
Harcourt St.
London W1H 1DT, U.K.
(01) 723-9408

XEC Products
13575 58th St. N, Suite 123
Clearwater, FL 34620
(813) 538-4190

Components

Processor: Hitachi HD6303X 8-bit CPU running at 1 MHz
Memory: 32K bytes of ROM; 32K bytes of RAM
Mass storage: Up to 256K bytes on EPROM Datapaks
Display: 16-column by 2-row LCD
Keyboard: 36 keys
I/O interface: 16-pin expansion port
Battery: 9-volt alkaline (life: approximately six months)

Size

$6 \times 3\frac{1}{4} \times 1\frac{1}{4}$ inches; 9 ounces

Documentation

Owner's manual

Price

\$249.95

Inquiry 854.

ware (18702 North Creek Pkwy., Bothell, WA 98011, (800) 343-8080). In fact, I can't imagine creating a list in any other way, since typing from the keyboard on the Wizard itself can be tedious. Wizard PC-Link can directly handle SideKick files, but not SideKick Plus files. It is not hard to use, and it closely resembles Lap-Link, also from Traveling Software.

The memo pad is useful for making notes to yourself, lists of things to do, and the like. The memo pad has the same limitations as other text entry on the Wizard. You can use the user dictionary to enter frequently used words and phrases, but unless you're entering or replacing a really long string with the user dictionary, any long memos become a real chore with this machine.

There are two calculators on the Wizard: a simple one with four functions, and another that uses the display as a paperless tape. The latter is a pleasure to use. The eight-line display acts as the paperless tape, and previous entries scroll up the screen so you can keep track of what you've already done. You can also edit previous entries, and the Wizard corrects the results. Unfortunately,

the Wizard's calculator supports only the four basic functions plus percentage and square root. This is a shame, because the display has enough room for complex math formulas and could show charts and graphs.

Optional Firmware

In addition to the built-in functions, Sharp offers three optional plug-in IC cards: Time Expense Manager (\$120), Thesaurus Dictionary (\$130), and 8-Language Translator (\$100).

The Time Expense Manager card has three applications plus its own separate 32K-byte RAM bank: a To-Do List Manager, an Expense Manager, and a Time Accounting Manager.

The To-Do List Manager sets up a list of tasks or projects. You can sort and view the list according to deadline date, to-do description, priority, manager name, or project name. The Expense Manager lets you enter traveling expenses for business trips. You can enter the expense description, date, type, amount, payment type, and whether you received a receipt. The Time Accounting Manager is designed to track billable time. You can enter information on client name; task name; date; starting, ending, and total time; and whether the time is billable or not.

The Time Expense Manager files can be transferred to your PC-compatible computer with Wizard PC-Link. PC-Link can also convert the files into the Lotus 1-2-3 format. The Time Expense Manager functions can also use the user dictionary to enter words and phrases to cut down on typing.

The Thesaurus Dictionary card can check the spelling of over 87,000 words. It also contains over 500,000 synonyms for 42,000 words. The dictionary and thesaurus are based on *The American Heritage Dictionary* and *Roget's II: The New Thesaurus*.

Finally, the 8-Language Translator card can translate 450 phrases and 760 words into any of eight languages: English, French, German, Italian, Spanish, Swedish, Japanese, and Chinese. The words and phrases are arranged into 13 categories, such as air travel, restaurant, sightseeing, and doctor. You're on your own when it comes to pronunciation.

I wasn't able to test the IC cards because they became available only after I wrote this review.

Using the Wizard

The Sharp Wizard is clearly aimed at the business user; that's why it slants its

continued

AST Introduces The Seven Wonders Of The Business World.

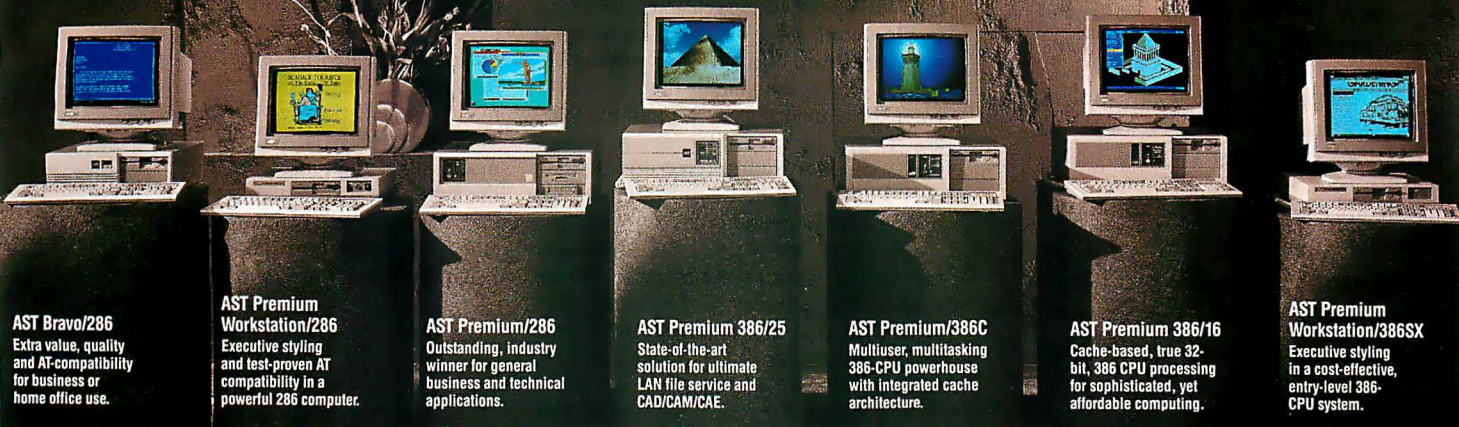

AST Bravo/286
Extra value, quality and AT-compatibility for business or home office use.

AST Premium Workstation/286
Executive styling and test-proven AT compatibility in a powerful 286 computer.

AST Premium/286
Outstanding, industry winner for general business and technical applications.

AST Premium 386/25
State-of-the-art solution for ultimate LAN file service and CAD/CAM/CAE.

AST Premium/386C
Multiuser, multitasking 386-CPU powerhouse with integrated cache architecture.

AST Premium 386/16
Cache-based, true 32-bit, 386 CPU processing for sophisticated, yet affordable computing.

AST Premium Workstation/386SX
Executive styling in a cost-effective, entry-level 386-CPU system.

AST makes the fastest and highest-quality desktop computers in the business world. One of them is right for you. Whether you need a personal computer for general office work, engineering, desktop publishing, financial analysis or running your business at home, you can count on AST to fit your desktop size, your budget and your need for ultimate speed.

| INFO WORLD REPORT CARD | | |
|--|--------------------------------------|---|
| AST Premium/286 | COMPAQ DESKPRO 386 [™] 2500 | IBM [®] PS/2 [™] Model 80-111 |
| 8.0 | 7.5 | 6.5 |
| Final Score - 28 MHz 386-Based Computers May 7, 1988 | | |

Our Newest Wonders. If you want extra performance and high quality without spending a lot of money, try our newest computers — the AST Premium[®] 386/16 and the AST Bravo/286. Our cache-based AST Premium 386/16 makes 386[™]-CPU computing available to even the most cost-conscious budget. And the AST Bravo/286 is all the AT[®]-compatible power you need for small or large businesses, home offices, or local area networks.

Our Most Powerful Wonders. For high-speed CAD/CAM/CAE, multitasking, multiuser environments and LAN file service, choose AST's top performing systems. The 25 MHz AST Premium 386/25 and 20 MHz AST Premium/386C bring the highest performance to your sophisticated 386-CPU based applications.

Our Most Versatile Wonder. If you have to choose one computer that satisfies the broadest range of needs, let it be the AST Premium/286. Perfect for flying through word processing, large spreadsheets and even technical applications, it's the industry's award-winner for 286 performance and value.

Our Smallest Wonders. When your desktop space



is limited, but your appetite for speed and power isn't, the AST Premium Workstation/386SX and the AST Premium Workstation/286 offer test-proven compatibility you can rely on. These sleek, small-sized wonders are the quality answer to cost-effective, high-performance desktop computing.



AST Service, Support And Reliability — The Eighth Wonder. The AST logo means quality products and service. In fact, PC Week recently named AST first in technical support, over Compaq[®] and IBM[®]*

For the products and service that will make you the next wonder of the world, ask for AST Computers. For more information, call (714) 863-0181 and ask for operator BB15, use our Bulletin Board Service number (714) 852-1872, or fill out the coupon.

Please send me information on AST computers. BYTE 5/89

Please have an AST representative call me.

I am an end user a reseller.

Name _____

Title _____

Company _____

Address _____

City/State/Zip _____

Phone _____

AST Research, Inc. 2121 Alton, Irvine, CA 92714-4992. Attn: M.C.



Times Have Changed.

*Source: PC Week, Nov. 14, 1988. AST, AST logo and AST Premium registered trademarks AST Research, Inc. 80386 and 80386SX trademarks Intel Corp. All other product and brand names are trademarks and registered trademarks of their respective companies. Copyright © 1989 AST Research, Inc. All rights reserved.

AST markets products worldwide — in Europe and the Middle East call 44 1 568 4350; in Japan call 81 3 818 0710; in the Far East call our Hong Kong office 852 5 606 4333; in Canada call 416 826-7514.

EZ-DOS

Break the stranglehold on your PC.

Digital Research & 2001 Sales have developed EZ-DOS as an enhanced replacement for your current DOS.

Now you can use the sophistication of EZ-DOS instead of accepting the limitations of another DOS.

The main features of EZ-DOS are:

- * DOS compatibility
- * Multiple 512 megabyte partitions - quit dissecting your hard disks
- * Password protection of files and directories
- * Full screen text editor
- * On-line HELP for command syntax
- * Command history
- * LIM 4.0 Extended memory driver
- * Menu based installation that works with all compatibles

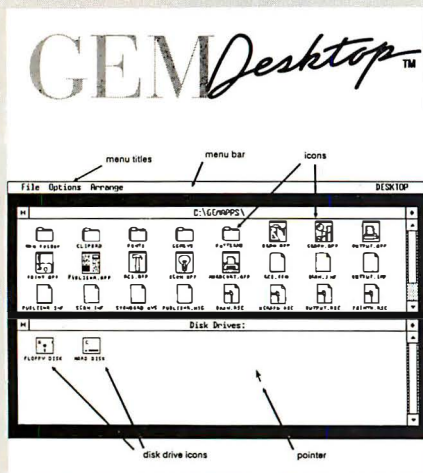

- * A true graphic, windowing operating environment - GEM/3 Desktop is our user interface.
- * Inexpensive - compare costs

EZ-DOS 4.1 Deluxe..... \$79.00
 plus True BASIC..... \$99.00
 plus serial Mouse..... \$139.00
 plus T.BASIC & Mouse.. \$159.00

2001 Sales, Inc.

16580 Harbor Blvd., Ste. D

Fountain Valley, CA 92708.

Tel: (714) 531-6551

Fax: (714) 531-8546

Dealer, Distributor & OEM Inquiries welcome.

VISA and Master Card accepted.

functions toward time management. I question, though, whether a busy executive will spend time laboriously pecking in the details of a luncheon meeting. It takes one-third of the time to enter information in my Day-Timer than it does to enter the same information into the Wizard. In any case, I find it hard to believe that someone would prefer this method over simply writing the information in a pocket appointment book.

Of course, the Wizard has advantages over a Day-Timer—the alarms, for example. The Wizard also has password protection on entries you want to keep secret, an advantage should your Wizard fall into the wrong hands.

In general, the Sharp Wizard is well designed. The keys, though tiny, are clearly marked. The letter and number keys are in separate sections of the keyboard, and you're not likely to confuse them.

The Psion Organiser II Model XP

The Psion Organiser is much more of a general-purpose computer than is the Sharp Wizard. It has a wide variety of software and hardware available, and it performs functions that are well beyond what the Wizard could ever hope to accomplish.

On the other hand, the Organiser is not the sleek executive's package that the Wizard is. It's thicker, the screen is smaller, and the keys are even more tiny than the Wizard's. Because of its size and shape, it resembles an enlarged scientific calculator.

Two factors immediately distinguish the Organiser from the Wizard. The first is that the Organiser has its own programming language. The second is that it has removable mass storage. This means that you can write and compile applications and then store them in a Datapak. The Datapaks are 16K- to 128K-byte EPROMs that function like disk drives; you can insert or remove them as needed. They cost from \$30 to \$150.

Commercial software is available on the Datapaks. They use the same A, B, and C designations as your PC's disk drives, and when you install a Datapak for the first time, the system formats it automatically. You can erase and reuse a Datapak by uncovering a clear window and exposing the chip inside to ultraviolet light.

Programming the Organiser

The Psion Organiser II's programming language, called OPL (Organiser Programming Language), has some of the attributes of both BASIC and the dBASE

language. While the Organiser contains a programming editor, the keyboard makes this difficult to use for anything beyond very short programs. You can, however, create the programs on any computer and upload them to the Organiser. The file transfer worked fine.

Because OPL is built into the Organiser, the functions and procedures of the language are available to everything on the system. This means that you can enter a formula into the calculator, define it as a procedure, and later use it in a

*It takes
 one-third of the time
 to enter information
 in my Day-Timer than
 it does to enter
 the same information
 into the Wizard.*

program. Likewise, procedures developed for use in a program can be used by built-in software, such as the calculator.

Organiser in Action

You open the Organiser by sliding it out of a gray plastic shell. Once the keyboard is exposed, it locks into place with a solid click. The screen displays a menu, and you can select a choice either by moving the cursor to the choice and pressing the Exe key or by pressing the first letter of the choice. The entire menu requires more space than is available on the two-line screen, so you can scroll the choices sideways by holding down the cursor-control keys.

As with the Wizard, a number of the Organiser's functions involve time management. You can set up to eight alarms and program them to go off once or repeatedly. The repeat on the alarm can be any period from once a week to once an hour. It also has a clock and an appointment calendar. Because the screen has only two lines, the time is set on the first line, and the details of the appointment on the second. If your appointment entry exceeds the 16-character screen width, it scrolls sideways. When you display the

continued

Would it hurt if you lost files on your hard disk without warning?

Would you like to make sure it never happens?

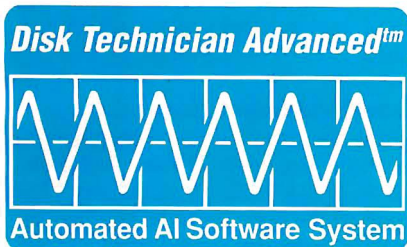

Now you can with *Disk Technician Advanced*: The world's only software that predicts, prevents and repairs the problems that cause costly file damage and loss. *Before* it happens.

PC MAGAZINE

"After witnessing a few minor miracles and a major miracle or two, I'm a believer."

Disk Technician Advanced finds and fixes all data-threatening conditions, recovers damaged or missing data, gets crashed systems up-and-running, even warns you when hardware is near failure! *Automatically.*

JOHN C. DVORAK

"If you're one of those souls who are plagued by hard disk problems, then take a look at *Disk Technician*..."

Disk Technician Advanced is fast and easy to use, too. There are no complex commands to learn.

You'll never need to remove and reinstall files and programs. Installation is a snap. And *Disk Technician Advanced* takes less than 10 seconds of your time to run. You simply press the ENTER key once. Then *Disk Technician Advanced* does the rest, automatically. *Unattended.*

WASHINGTON POST

"The most sophisticated data protection for IBM PCs is Prime Solutions' *Disk Technician Advanced.*"



Why go through the pain of recovery routines? Disk Technician Advanced stops disasters before they happen ...

So get the world's only software that eliminates the fear of a disk crash. By preventing it from happening in the first place. Only \$189.95. Call now for the dealer nearest you, or to order direct.

800 847 5000 - 619 274 5000

PRIME SOLUTIONSsm

We Make Technology Easy And Affordablesm

Prime Solutions Incorporated
1940 Garnet Avenue • San Diego, CA 92109 USA

Disk Technician Advanced is designed to work on IBM PC, XT, AT, PS/2 and true clones using DOS 2.1 to 3.32. Not copy protected.

All trademarks and servicemarks are acknowledged.

"Why do I need Disk Technician Advanced if...

...I backup every day?" A very wise practice. But when considering "hard disk disaster preparedness," think of backup as your "reconstruction" partner, and *Disk Technician Advanced* as your *prevention* partner. Backups cannot *prevent* file loss and damage. *Disk Technician Advanced* is the world's only software capable of this. Nor are your problems solved when you restore your files to the hard disk. You will most likely be putting good files into dangerous areas that will crash again. *Disk Technician Advanced* assures you that files are kept safe, because *Disk Technician Advanced* maintains the hard disk itself in perfect shape. Besides, who wants to waste time reloading and reinstalling files and programs when the problem could have been *prevented* in the first place? And what about all of the work you have lost forever since your *last* backup? *Prevention* is the key.

...I use Norton, Mace, PC Tools, SpinRite, Optune, etc.?" All of these products, at best, *may* help you *after* a disaster has already occurred. Not a single one of them can find and fix all hard disk problems *before* disaster strikes. *Disk Technician Advanced* is the world's only software that can actually predict, repair and prevent file loss and damage *before* it happens.

...I optimize (defragment) my hard disk?" *Disk Technician Advanced* does not defragment your files. But if you use a defragmenter without *also* using *Disk Technician Advanced*, you will most likely be relocating good files into undetected bad spots and actually *cause* a crash. *Disk Technician Advanced* is the world's only software that can find and repair 100% of the bad spots. So you do not have to worry about losing or damaging files again.

...My hard disk is brand new (or, 'I've never had a problem with my hard disk.') Every hard disk will lose data. Every hard disk will crash. It's not a question of 'if,' it is only a matter of 'when.' *Disk Technician Advanced* prevents file loss and damage from happening by repairing and maintaining your hard disk in perfect condition throughout its lifetime. And, eventually, when your hard disk is about to totally fail, *Disk Technician Advanced* is the world's only software that will warn you that it is about to happen, *before* you lose your valuable files, data and programs.

TECH*GRAPH*PAD

Still
trying to get
Engineering
& Scientific
graphs
from a
Business
program?

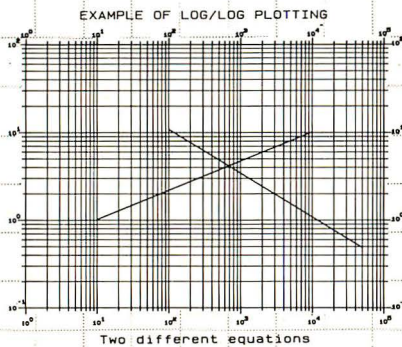
**TECH*
GRAPH*
PAD**

Easy-to-use technical graphing & plotting software for engineers & scientists. Compatible with Lotus 1-2-3 worksheets, other spreadsheets, PRN & ASCII files, & most data acquisition packages.

Now shipping Version 3.0!

- X-Y, Semi-log, Log/Log, Polar Plots
- Curve Fitting • Data Smoothing
- Labels, Scale, & Color Control
- Multiple X-Y Axes
- Error Bars • Greek Letters
- Laser Printer, Plotter, Printer Output
- IBM PC/XT/AT, PS/2, Apollo, DEC compatible

CALL

(617) 890-1812

Dealer Inquiries Invited

 **binary engineering**

100 Fifth Ave., Waltham, MA 02154

line, it scrolls sideways automatically.

The Organiser's Save function is a sort of free-form database. Anything you save, such as names, phone numbers, addresses, notes, or other data, is retrievable via the Find function, also accessed from the main menu.

The Organiser's calculator program allows far more sophistication than the Wizard's, partly because the calculator has additional capability built in, but also because it has access to math routines that are part of the OPL language. These routines include trigonometric functions, and they can include any procedures that you wish to define yourself.

The small screen makes the excellent calculator program harder to use, because you can see only a small part of a formula at a time. You can scroll through it, but this is less convenient than having it all on the screen.

Two of the menu choices reflect the use of Datapaks for mass storage. Info shows you how much space is available in the storage locations, and Copy lets you copy files from one Datapak to another in much the same way that you would copy between disks on other machines.

Commercial Software

The Psion Organiser II has a strong following in both the U.K. and the U.S. This encourages a reasonable variety of commercial software, which in turn makes the computer more attractive. The Organiser that I reviewed came with a communications package, a spreadsheet program compatible with Lotus 1-2-3 versions 1 and 2, an enhanced calculator program, a database package, and a development environment for OPL programs. I'm not going to review the software, but it was easy to install and use and, more important, worked well in conjunction with a desktop personal computer.

The communications package, Comm Link (\$100), forms an important part of the Organiser's environment, however. It consists of an EPROM and cable that plugs into the top of the Organiser and PC-compatible software. With this combination, you can transfer files between your Organiser and a PC.

To this extent, the Organiser and the Wizard are much alike, since the Psion Comm Link and Sharp's Wizard PC-Link perform much the same functions. The Psion product can do much more, however. It also acts as a terminal package, and it can do ASCII and XMODEM file transfers with any computer. This means that you can use the Psion Organiser as a terminal to connect with BIX.

While the tiny screen is a handicap, telecommunicating with the Organiser is possible.

Peripherals

While printers are available for both the Wizard and the Organiser, you can also get bar code readers, magnetic card readers, and a modem for the Organiser.

These peripherals are supported by software for applications such as meter reading, inventory, point-of-sale record keeping, sales route management, and marine navigation. These are all applications for which the Organiser is well suited, and they help to explain its popularity.

Hand-Held Impressions

During the review, I found myself using the Psion Organiser II more and more, and the Sharp Wizard less and less. I had expected the opposite to be the case, especially given the larger screen and better keyboard design of the Wizard. However, the Wizard didn't fill a niche for me. It was designed to be a replacement for a Day-Timer, and while it does indeed fill many of the same functions and adds others, it is harder to use. I might have had a better impression of the Wizard if more software had been available.

The Psion Organiser, on the other hand, continued to be useful, partly because it is a little easier to use. The machine operates entirely from menus. In addition, the software is consistent among applications. You always use the Exe key to select and run a menu choice. You always use the Mode key to change between Datapaks.

More important, the Psion Organiser is more flexible. You can program it to do what you need it to do, and commercial software is available to meet most needs. Interestingly, even the appointment functions seemed well thought-out in the Organiser; for example, you can automatically set the alarm for a meeting for a period of time ahead of the meeting.

The ideal hand-held computer would have the functionality of the Psion Organiser II and the design of the Sharp Wizard. I choose the functionality and flexibility of the Psion Organiser II over the construction of the Sharp Wizard. ■

Wayne Rash Jr. is a consulting editor for BYTE and a member of the professional staff of American Management Systems, Inc. (Arlington, VA). He consults with the federal government on microcomputers and communications. You can contact him on BIX as "waynerash," or in the to.wayne conference.



| | |
|-----------------------------|------|
| PS/2 model 30/286 | 1949 |
| PS/2 model 50/30 meg | 2795 |
| PS/2 model 70/60 meg | 3895 |
| PS/2 model 60/71 meg | 5495 |
| PS/2 model 80/40 meg | 4485 |
| PS/2 model 80/115 meg | 6595 |

Call for other models



| | |
|----------------------------------|------|
| 386 S 40 meg | 3595 |
| 386 20E - 40 meg | 4595 |
| 286 40 meg | 2195 |
| 386 110 meg/25 MHz | 7495 |
| 386 60 meg/25 MHz | 5895 |
| Portable III 40 meg/12 MHz | 4095 |

CARD & MONITOR EXTRA
Call for other models



| | |
|-------------------------|------|
| Mac-SE/20 Meg | 2849 |
| Mac-II/40 Meg | 4249 |
| Mac-SE-20 DR | 2295 |
| Call for 6C and 100 Meg | |
| Lazer NT | 3595 |
| Lazer NTX | 5195 |

LOW PRICE LEADER

SINCE 1983
LAP-TOP

| | |
|-------------------------|------|
| Compaq SLT 286-20 | Call |
| SLT 286-40 | Call |
| Toshiba T1000 | 769 |
| T1200F | 1395 |
| T1200HB | 2395 |
| T1600 | Call |
| T3100E | Call |
| T3200-40 Meg | 3495 |
| T5100 | 4495 |
| Zenith Supersport | |
| 286-20 Meg | 3195 |
| 286-40 Meg | Call |
| 8088-20 Meg | Call |
| Epson LT | Call |
| NEC Lap-Top | Call |
| Mitsubishi 286-20 | 2595 |



Step 286 - 12 & 16 MHz & 20 MHz
1 Meg RAM
Set up utility in ROM
S/P, C/C
Enhanced keyboard
1.2 MB floppy
DOS/BASIC

Call! for
your
configuration



Step 386-20 MHz & 16 MHz & 25 MHz
256K cache of very high speed RAM
2 Meg RAM, expandable to 16 Meg
S/P, C/C
Enhanced keyboard
1.2 MB floppy
DOS/BASIC

Call!

Everex 1800 Available



| | |
|--------------------------|------|
| AST 286 model 140 | 2595 |
| AST 286 model 80 | 1495 |
| AST 386 model 300c | Call |
| AST 386 40 Meg | 3495 |

CARD & MONITOR EXTRA
CALL FOR OTHER MODELS

WE STOCK

CITIZEN
OKIDATA
EVEREX
GOLD STAR

TOSHIBA
NEC
WYSE
HITACHI

PRINCETON GRAPHICS
SONY
ACER
HOUSTON INSTRUMENTS

AMDEK
HAYES
SAMSUNG
CALCOMP

PC MOUSE
MICROSOFT MICE
LOGITECH
MITSUBISHI

IRWIN & ARCHIVE
TAPE BACK
TAXAN
MAGNOVOX

BOARDS

| | |
|----------------------|-----|
| Paradise VGA + | 285 |
| Vega VGA | 299 |
| Everex EVGA | 265 |
| Everex EGA | 179 |
| Tatung 16 bit | 275 |

SOFTWARE SPECIALS

| | |
|-------------------------|-----|
| dBase IV | 455 |
| Wordperfect | 239 |
| Aldus Pagemaker | 459 |
| Ventura Publisher | 475 |
| Clipper | 415 |
| Quatro | 145 |



NOVELL
Authorized
Dealer

PRINTERS

EPSON

| | |
|---------------------|---------|
| LX-800/LQ-500 | 195/315 |
| LQ-850/1050 | 535/735 |

OKIDATA

| | |
|---------------|---------|
| 320/321 | 359/490 |
| 390/391 | 490/649 |

TOSHIBA

| | |
|----------------------|---------|
| 321-SL/341-SL | 475/595 |
| 351-SX 350 CPS | 945 |

BROTHER

| | |
|-------------------|-----|
| 1709-9 PIN | 425 |
| 1724-24 PIN | 595 |

LASER PRINTERS

| | |
|----------------------|------------|
| HP Laser II | 1695 |
| HP Desk Jet | 675 |
| Panasonic 4450 | 1549 |
| Brother HL-8 | 1949 |
| Nec LC 890 | 3195 |
| PageLaser 12 | \$\$\$\$\$ |

MONITORS

| | |
|----------------------------|------|
| Nec Multisync IIA | 525 |
| Nec Multisync II | 575 |
| Nec Multisync Plus | 899 |
| Nec Multisync XL-19" | 2295 |
| Samsung EGA | 359 |
| Goldstar VGA | 375 |

FAX MACHINES

| | |
|--------------------|------|
| Sharp FO 220 | 895 |
| Sharp UX 350 | 1249 |
| Canon | Call |
| Brother | Call |
| Richo | Call |
| Murata | Call |

Intel Coprocessors

| | |
|----------------|-----|
| 8087-3 | 105 |
| 8087-2 | 145 |
| 80287-8 | 235 |
| 80287-10 | 275 |
| 80387-16 | 409 |
| 80387-20 | 499 |
| 80387-25 | 639 |

MODEMS

| | |
|-----------------------|------|
| Everex 1200 Int | 89 |
| Everex 2400 Int | 159 |
| Hayes 1200 B | 289 |
| More in Stock | Call |

WE ACCEPT LC, CASHIER CHECKS, MONEY ORDERS, VISA, MC, AmEx
3% charge on VISA, MC & 5% on American Express

EXPORTS
Available

COMPUTERLANE

HOURS:
M-S 9-6

1-800-526-3482 (Outside CA)
(818) 884-8644 (In CA)
(818) 884-8253 (FAX)

22107 ROSCOE BLVD.
CANOGA PARK
1/2 BLOCK W. OF TOPANGA
CA 91304

CORPORATE ACCOUNTS WELCOME
CALL FOR VOLUME DISCOUNTS
CONSULTANTS CALL FOR PRICING

Prices subject to change without notice

Compaq is a Registered Trademark of Compaq
IBM is a Registered Trademark of International Business Machines

Microsystem Engineer's Personal Assistant

Programs all 24 & 28 pin PROMS

S3 can program every current 24 and 28 pin EPROM & EEPROM, as it comes, with no attachments, using one of eighty-four different algorithms. And it's FAST. Every byte of a 27C256 will program in less than 20 seconds, including a complete final check. S3 has a User RAM buffer, 64K-bytes long, to hold your code: it can load and program a 27512 in a single pass.

Battery powered and Portable

S3 is the ideal tool for engineers on the move. It is powered by a rechargeable battery. On a full charge, it will do several days' work, including programming hundreds of PROMS. S3's battery retains the data in the 64K-byte RAM even when switched off. You can take-up just where you left-off. Some labouring engineers don't appreciate the portability of S3 right away. Then they realise that they can reach for S3 and fix a problem quickly. It is self-contained. You can take it to a computer to download a file, and start programming as you walk across to the equipment which needs the new PROM. S3 changes the way you work.

Serial Communications by RS232

S3 has the standard D25 socket for RS232 communication, at baud rates from 300 to 9600. Because transmission-time is not defined by baud-rate (you knew that), what matters most is that S3 will receive a file at 9600,N,8,1 at full speed without handshaking.

Remote Control by Computer

Every feature of S3's keyboard also works by remote control via the serial interface. The big screen computer display can be useful – for example, when you are comparing PROMS with many differences. Batch files can be used for repetitive tasks. Any comms or terminal software will work.

ROM Emulation

As a ROM Emulator S3 has no equal. S3 is a ROM emulator with PROM blowing and editing facilities too, and will emulate any 25 or 27 series PROM up to 27512. It has an *EmuLead*: a couple of feet of ribbon cable terminated by a 24 or 28 pin plug, which can take the place of a PROM in-circuit. A feature you will not find in other ROM-Emulators is *RAM-Emulation*. Because ROMS do not have a write-input, S3 is provided with a separate *write-lead* which can be clipped to the micro-processor's write-pin. This opens new possibilities – the target system can now write into S3. All RAM data can be inspected and modified. You can put the *system stack* and *variables* into the same area as the *program*. You can write your own *breakpoint routine*, adjust variables when testing and so on.

Microsystem Development

Assemblers generate object files which can be downloaded to S3, in INTELHEX, MOTOROLA, TEKHEX, BINARY – or just plain ASCII. Using the *EmuLead*, the code can be tried out in the system under development. When the code works, it can be transferred immediately to PROM. S3 is particularly suitable for the "piggy-back" type of microcontroller. We offer an excellent Editor/Assembler/Comms software package which, although developed for us, not by us, we endorse because we use it and believe in it. It's fast, convenient and crammed with powerful features. A single keystroke will assemble, link and down-load your code. If an error is encountered it will pick-up the source-file and put the cursor in the error-line. Who needs an unfriendly environment when



they're struggling with microsystem development?

S3 itself is Programmable

S3 is all-CMOS, all-SMT. It has a 4K-bytes of BIOS in masked ROM, which handles the INS and OUTS and loads the working program. The Transient Program Area is a further 8K-bytes of RAM, separate from the 64K-bytes of User RAM, and also battery-supported whether S3 is ON or OFF. When S3 is supplied the TPA contains the latest version of the working program – and you get a copy in a backup PROM. The program in the TPA is permanent, until you

decide to change it. To load new software into the TPA, you put the PROM in the socket and key an instruction; the change can be accomplished in only three seconds.

Free Upgrades

Our method of installing new software allows us to offer free upgrades. You will need to program newer, faster PROMS when these come along. The most recent programs are kept on our bulletin board and they can be freely copied. You can download for the price of a phone call.

30 days money-back trial period.

S3 has been enthusiastically received in the UK & Europe during the past 12 months. Returns during the trial period are less than 1%.

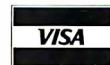

Lombard House, Cornwall Rd,
DORCHESTER, Dorset DT1 1RX,
England
Phone 0305-68066
Fax 0305-64997
Telex 418442
Bulletin Board 0305-251786
300/1200/2400,N,8,1 (24hr)

Price List

| | |
|--|------|
| S3 PROM Programmer/Emulator | £495 |
| includes Backup PROM, EmuLead, Write-Lead, Manual & Charger | |
| Editor/Assembler | £195 |
| most microprocessors are covered – send for a list | |
| Developer's Package | £195 |
| Used for modifying S3's working program. Contains Editor/Assembler for NEC µCOM87, Circuit Diagram, BIOS calls and SOURCE CODE. | |
| 32 Pin EPROM Module | £75 |
| 32 pin EPROMS, 1 meg and up | |
| 40 Pin EPROM Module | £75 |
| 40 pin EPROMS, 1 meg and up | |
| 8748/8749/8741/8742 Module – | £125 |
| XICOR 2212 – | £45 |
| EPLD Module | £295 |
| Erasable Programmable Logic is a powerful technology which is cheap and easy to learn. EPLD prices have come down lately. Some EPLD makers even give away their logic compilers. Our EPLD package complements the manufacturer's software. It loads JEDEC files, burns and copies common EPLDS with 20, 24 and 40 pins from CYPRESS, ICT, MMI/AMD, INTEL, ALTERA, GOULD and TEXAS. | |
| Software upgrades will appear on the Bulletin Board. | |
| Note – modules plug into S3. | |
| S3 guaranteed 3 years, both parts and labour. | |
| Other hardware 1 year. UK customers please add VAT. | |



Easy Reading

TrueScan and OmniPage offer page-recognition capabilities for the Mac or AT

Phillip Robinson

Personal computers may be marvelous at 'rithmetic and 'riting, but they've been embarrassingly dim-witted when it comes to the third "r": reading. Desktop optical character recognition (OCR) has suffered from restricted font intelligence and an inability to read mixed text and graphics. That's changing with the use of 32-bit processors and new algorithms.

Instead of simply reading dot-matrix printer documents back into ASCII files, the goal now is to capture all the text, graphics, and formatting complete with position, type style, and other attributes. The result is stored in a variety of formats for use with word processors, spreadsheets, and page-layout programs.

Calera Recognition Systems (formerly Palantir) and Caere Corp. have both developed page-recognition systems for the IBM PC AT and compatibles. Built around Motorola's 68020 accelerator, Calera's TrueScan and Caere's OmniPage both consist of a full-length add-in board, 2 to 4 megabytes of RAM, and software. Caere also offers a software-only version for the Macintosh SE and II.

The two systems present somewhat different approaches to page recognition and have different strengths. Each works with a wide range of optical scanners. I tested the systems on a 10-MHz AT clone with 640K bytes of RAM, a 40-megabyte hard disk drive, and a VGA adapter and

monitor. I used an AppleScanner and an HP ScanJet and ScanJet interface card.

Important factors for page recognition include accuracy, speed, and ease of use. Accuracy concerns the types of text that the system can read and what structures and formatting it recognizes. Both systems recognize such items as subscripts, superscripts, tables with tabs, centering, justification, word wrap, and attributes such as italics and boldface, and they preserve them as control functions in Microsoft Word and other file formats. Speed depends on the scanner used, the efficiency of the recognition process, and the time it takes to convert the data to a particular format.

TrueScan

TrueScan 1.1 provides drivers for over a dozen scanners; can translate TIFF files and fax image files from GammaLink, SpectraFAX, Datacopy, and AT&T fax boards; and converts the results to ASCII, Excel, Lotus 1-2-3, and a variety of word processing file formats (including DCA, DisplayWrite, Word, MultiMate, OfficeWriter, PFS:Write, Samna, Volkswriter, WordPerfect, WordStar, and XyWrite). It saves images as PC Paintbrush, TIFF (uncompressed, modified Group 3, or packbits), CCITT Group 4 compressed fax, or Ventura Publisher files.

TrueScan recognizes typewritten, typeset, laser-printed, and dot-matrix fonts from 6 points to 28 points in monospace or proportional spacing. It recognizes variable-width, multicolumn text, including tables created with tabs. It also knows to enter a hard carriage return only after the last sentence in each paragraph. TrueScan can scan for text, graphics, or both, producing separate text and image files from a single pass.

I tested Calera's standard (S) and extended (E) versions of the TrueScan board. The \$3995 Model E has 4 megabytes of RAM and three custom ICs; the Model S (\$2745) has 2 megabytes of

RAM and two custom ICs. Calera claims that the Model E reads up to 100 characters per second versus 75 cps for the Model S. The Model E also handles landscape page orientation.

You plug the TrueScan board into a 16-bit, full-length slot and run a batch installation file. The software eats up a little over 3.5 megabytes on your hard disk. Initially, I had trouble finding a free address for the board, but the software's memory-map utility helped in my search for free memory.

SCANTEXT reads the text and saves it in the default text format. SCANIMG scans the page as an image and saves it in the default graphics format. SCANBOTH performs both scans in one pass. SCANFILE analyzes text from an image file saved on disk. TRUESCAN brings up the main menu, from which you set the default formats and scanner settings.

During a scan, an on-screen clock indicates start and end times and reports the total time taken to read the document. When the analysis is complete, you tell TrueScan to save the file to disk in the preselected format. This conversion process takes 3 to 15 seconds. You can't see the results, however, until the scan is complete, saved as a file, and loaded into the appropriate application. You can save scanned pages as separate files or store multiple pages in one file.

Software-controlled scanner settings include contrast, text type, page orientation, document source (scanner or disk file), and scan type (image, text, or both). You choose scanning boundaries by entering inch measurements for the four edges, and you can select scanning format (binary, 16 gray scales, or four different dither patterns) and resolution (from 48 dots per inch to 600 dpi).

TrueScan flags characters it doesn't recognize with an asterisk and displays its best guess as to what the character or word should be. You can change the flag character or turn it off.

continued

OmniPage 1.0

Type

Page-recognition board and software

Company

Caere Corp.
100 Cooper Court
Los Gatos, CA 95030
(408) 395-7000

Features

AT version: Full-length board with 68020 accelerator and 2 megabytes of RAM

Mac version: Software only

Both versions: Text recognition at 40 cps to 150 cps; real-time viewing of text during processing; ability to read fonts from 6 points to 28 points; basic text editing

Hardware Needed

AT version: IBM AT or compatible with 20-megabyte hard disk drive, 640K bytes of RAM, graphics adapter, monitor, and mouse; HP ScanJet, Canon, or any scanner that supports uncompressed TIFF files

Mac version: Mac II or SE (with 68020 accelerator); 4 megabytes of RAM (5 megabytes if used with MultiFinder); AppleScanner

Software Needed

AT version: DOS 3.1 or higher
Mac version: System 4.2 or higher

Documentation

User's manual

Price

AT version: \$2495
Mac version: \$795

Inquiry 855.

TrueScan's proprietary recognition algorithm set first performs topological feature extraction to identify characters, looking at the existence and position of bays (open concavities), lakes (closed-in areas), curves, and lines. Then, to break deadlocks between possible character choices, it relies on a dictionary. This helps it make intelligent guesses about word spellings and letter pairings. For example, TrueScan might avoid "truu" in favor of "true" and flag the word.

OmniPage

OmniPage 1.0 for the IBM AT (\$2495) includes software and a board with a 68020 accelerator, 2 megabytes of RAM, and its own multitasking operating system. The software includes a run-time version of Microsoft Windows. Under Windows 286 or Windows/386, Omni-

TrueScan 1.1 Model E

Type

Page-recognition board and software

Company

Calera Recognition Systems, Inc.
2500 Augustine Dr.
Santa Clara, CA 95054
(408) 986-8006

Features

Full-length board with 68020 accelerator and 4 megabytes of RAM (2 megabytes on Model S); text recognition of 8- to 72-point text at 100 cps (75 cps on Model S); landscape or portrait scanning; simultaneous image and text capture

Hardware Needed

IBM AT or compatible with 512K bytes of RAM, a 20-megabyte hard disk drive, a monochrome monitor, and a scanner

Software Needed

DOS 3.1

Documentation

User's manual

Price

Model E: \$3995
Model S: \$2745
Model E upgrade: \$1495

Inquiry 856.

Page can operate in the background. The AT version includes drivers for the HP ScanJet and Canon scanners.

At \$795, the Macintosh version of OmniPage is much less expensive, but it doesn't include a board—this package is software only. It uses the CPU in your Mac SE or II and requires 4 megabytes of RAM (I recommend at least 5 megabytes). While its capabilities are identical to those of the AT version, the Mac version offers fewer file-saving formats (TIFF, ASCII, MacWrite, and Excel) and a driver only for the AppleScanner.

Caere claims a speed of 40 cps to 150 cps for both Mac and PC versions. The OmniPage algorithm starts by defining the dense areas of each page. Next, it checks for the presence of columns, checks for the empty areas between lines and paragraphs, and then finds the hori-

zontal and vertical alleyways between characters. OmniPage compares text against a variable-size character matrix. The software doesn't try to guess unknown characters or correct misspellings; it marks each unreadable character's position with a tilde.

OmniPage recognizes all nonstylized fonts from 8 points to 72 points. It can handle variable-width columns; various type styles; typeset, proportional, and kerned text; partial pages and forms; and graphics.

As with the TrueScan, I had trouble finding a free address for the OmniPage board, but once I found the right switch combination, the installation went smoothly. Using OmniPage was a matter of getting into Windows and starting the program. By contrast, the Mac version was relatively easy to install; it only had card addresses to worry about and a quick SCSI connection to the AppleScanner. Settings and commands appear in pull-down menus. The program includes a tutorial with examples, menu explanations, and a glossary.

The software is more graphically oriented than TrueScan's; on the AT version, it displays each letter that it's reading in a small window as the scan progresses (the Mac version lacks this feature). It also deposits the scanned image or recognized text in a transitional editor window where you can view it before saving to disk. The transitional editor also offers zoom in and out options for graphics, as well as cut, copy, paste, and search and replace functions for text.

OmniPage can handle mixed graphics and text on a page, but it can't save both a recognized-text file and a graphics image file from a single scan. It can save graphics scans as TIFF or uncompressed TIFF files, and it recognizes text in a wide variety of word processor and spreadsheet formats, including Microsoft Word, WordPerfect, MultiMate, Excel, and Lotus 1-2-3. OmniPage can also recognize text stored in TIFF files and in fax files saved as uncompressed TIFF files.

From an initial window in OmniPage, you can choose to scan text or graphics at the default settings, or move to the main program window. There, you can choose your own scanner, text, and graphics settings. These include resolution (200 dpi to 300 dpi), tone (line art, halftone fatting, or halftone Bayer), contrast, image type, and document size. Halftone Bayer dithering is useful when image resolution is more important than its contrast. Halftone fatting is for continuous tone

continued

Verbatim
Minidisks
2S/2D
MD 2
40 tracks/side at
48 TPI



DataLife

10 Minidisks
2S/2D
MD 2

DataHold
anti-static liner
Lifetime Warranty

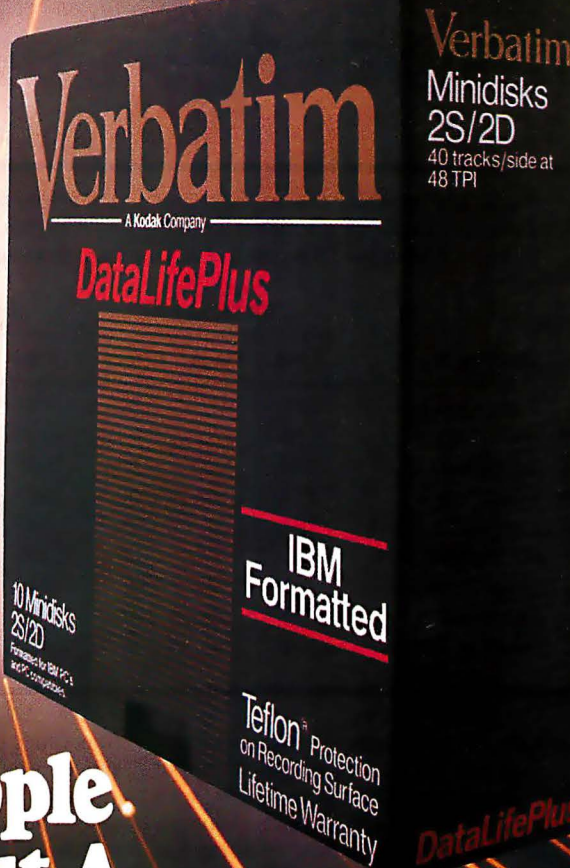

10 Minidisks
2S/2D
Formatted for IBM PCs
& compatible computers

IBM
Formatted

Teflon[®] Protection
on Recording Surface
Lifetime Warranty

DataLifePlus

For People Who Put A Premium On Performance. And Protection.

The more invaluable your data is to you, the more you'll value Verbatim.[®] Because when it comes to high performance and data protection, Verbatim has the winning combination no other floppies can copy.

Consider this: Verbatim DataLife[®] floppies are engineered to perform an average of 50 million revolutions. That's 15 times the industry standard.

Then consider that Verbatim DataLifePlus[™] and DataLife HD 5¼" disks were the first floppies to be factory formatted.

Verbatim also gives you plenty to consider when it comes to data protection. After all, nearly 50% of all computer users have lost time and money due to accidental data loss. That's why Verbatim offers advantages like DataHold[™] and DataHold II

anti-static liners. So static charges are dispersed before they ever have a chance to build up.

For the world's ultimate data protection, DataLifePlus floppies have an exclusive DuPont Teflon[®] coating. So fingerprints and spills can be easily wiped from the recording surface.

And of course, all Verbatim floppy disks are tested to be 100% error free and are backed by a lifetime warranty.

Verbatim data cassettes and cartridges, 8", 5¼" and 3½" diskettes. For people who put a premium on performance and protection.

For more information on the full line of high-quality Verbatim products call 1-800-538-8589.

© Teflon is a DuPont registered trademark.

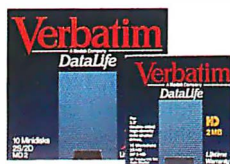

 **Verbatim**
A Kodak Company

DOING MORE FOR THE DATA PROCESS[™]

Table 1: Processing times, flags, and actual errors produced by TrueScan and OmniPage on nine sample documents. Times are totals for document scanning and recognition. TrueScan times do not include initial software downloading to the board, which takes 10 seconds. (All times are in seconds; N/A = not applicable.)

| Document | OmniPage AT | | | OmniPage Mac | | | TrueScan Model E | | | TrueScan Model S | | |
|---------------------|-------------|-------|--------|--------------|-------|--------|------------------|-------|--------|------------------|-------|--------|
| | Time | Flags | Errors | Time | Flags | Errors | Time | Flags | Errors | Time | Flags | Errors |
| Press release | 202 | 17 | 8 | 197 | 14 | 20 | 169 | 107 | 10 | 167 | 103 | 10 |
| Microbytes | 178 | 2 | 7 | 203 | 18 | 25 | 255 | 115 | 14 | 317 | 116 | 12 |
| Adobe fonts | 310 | 111 | >100 | 271 | 40 | >100 | 208 | 170 | >100 | 255 | 185 | >100 |
| Spec sheet | 217 | 50 | >100 | 283 | >250 | >250 | 134 | 135 | >100 | 182 | 163 | >150 |
| Dot-matrix printout | 167 | 37 | >50 | 147 | N/A | >75 | 58 | N/A | 7 | 58 | N/A | 3 |
| Income statement | 97 | 7 | 18 | 210 | N/A | >50 | 128 | N/A | 4 | 188 | N/A | 50 |
| Legal contract | 124 | 14 | 45 | 245 | >100 | >200 | 144 | 23 | 20 | 219 | 85 | >100 |
| Newspaper story | 203 | 16 | 30 | 86 | 4 | 15 | 196 | 62 | 25 | 247 | 56 | 30 |
| Newspaper table | 135 | 3 | 4 | 182 | N/A | >75 | 101 | N/A | 5 | 121 | N/A | 15 |

images, for good contrast and resolution.

Text settings include input and output page layout, document page length, scan area, and output file format. You can finely adjust the scan area; zooming lets you inspect the image pixel by pixel. A Statistics function counts recognized and unrecognized characters, gives the recognition percentage, and appends the information to the end of the file.

The Auto Galley function decolumnizes text on each page and puts it into the proper sequence in the output file. Unlike TrueScan, OmniPage also offers a Manual Galley feature that lets you choose the appropriate sequence for decolumnized text. This is useful for pages where text doesn't flow logically from one column to the next. Auto Paste-Up preserves the columnar format, for word processors that support snaking columns. The Financial Forms setting preserves decimal tabs in the text.

When you begin a scan, you see the scanner's progress on the display. First, OmniPage locates areas of text and graphics on the page. Next, the software draws boxes around regions within the text and art, and it labels each box in numerical order; each paragraph and graphical component is a new area. Then the software processes the contents of each area, and, in the AT version, a window on the left side of the screen shows magnified images of the characters that OmniPage is analyzing.

On the AT, the software doesn't time the process, nor does it automatically save a file in a preselected format. That's done by a batch file that kicks in when you leave Windows. If you forget to leave Windows before turning off your machine, you'll lose the data.

After performing multiple scans,

sometimes the batch file converts only a single saved .TMP file into the appropriate target format. Also, where TrueScan saves Excel files, for instance, with formatting, OmniPage saves only the values.

OmniPage 1.1 should be available by the time you read this. It offers several improvements over version 1.0, including better format conversions for MultiMate and WordStar, and drivers for the DEST and Microtek scanners. The Macintosh version adds the character window and fixes some bugs running under System 6.02.

Face-Off

To compare TrueScan and OmniPage, I scanned a variety of documents and then saved them in TIFF, Word, and Excel formats on the AT and in ASCII and Excel formats on the Mac. I logged the time to scan and recognize each document and checked the accuracy of each scan by looking at the file in the appropriate application (e.g., Excel or Word). I looked for both flagged and unflagged errors. The results appear in table 1.

While all the flags that OmniPage set indicated read errors, TrueScan marked unfamiliar or misspelled words, so not all flags pointed to actual errors. Because of the different hardware, performance times aren't directly comparable between the Mac and AT products.

I scanned nine documents, starting with a press release with three pages of single-column text on a gray background. The second scan was from the Microbytes section of BYTE (see figure 1). Four columns of text, plus several stories per page with white and yellow backgrounds, made this more challenging. Then came a page of 16 Adobe font samples, typeset, from Palatino and Helve-

tica Condensed Light to Park Avenue, Bodoni, and Sonata. The fourth scan was the back of a spec sheet for a laptop computer, sporting two columns of red and black type on a white, glossy surface.

The fifth and sixth scans were tabular, and so were aimed at the spreadsheet formats. The fifth was a photocopy of a dot-matrix printout with 5 columns and 20 rows of database report information. The sixth was a bank statement of income, printed in brown type on a white background. This included lengthy labels on the left side of the page and several columns of figures on the right.

The final text scans included the first page of a legal contract (scanned at letter size due to scanner limitations); a clipped, three-column newspaper story; and a table from the same newspaper.

The TrueScan Model E was usually—but not always—faster than the Model S. On the first test, it virtually tied with the Model S, but on the second and third it was 20 percent to 25 percent faster. It also recorded fewer mistakes on some of the more complicated scans, such as the Adobe fonts. Sometimes the difference was impressive: A scan that was pedestrian for the Model E and the OmniPage—the bank statement—was a disaster for the Model S. But, comparing the \$1495 cost of an upgrade from the Model S to the Model E to the \$1250 difference in their initial prices, I might pick the Model S first and see if it met my needs.

The Mac version of OmniPage was usually slower than its AT counterpart. The legal contract, however, was 2.5 times faster on the Mac. The Mac version was also less accurate than the AT version, but this might be due to the different scanners used. The Mac results were

continued

Discover Parallel Processing!

Monoputer/2™

*The World's Most Popular
Transputer Development System*

Since 1986, the MicroWay **Monoputer** has become the favorite transputer development system, with thousands in use worldwide. Monoputer/2 extends the original design from 2 to 16 megabytes and adds an enhanced DMA powered interface. The board can be used to develop code for transputer networks or can be linked with other Monoputers or Quadputers to build a transputer network. It can be powered by the 20 MHz T414 or T800 or the new 25 MHz T425 or T800.

Parallel Languages

Fortran and C Make Porting a Snap!

MicroWay stocks parallel languages from 3L, Logical Systems and Inmos. These include one Fortran, two Cs, Occam, Pascal, and our own Prolog. We also stock the NAG libraries for the T800 and Rockfield's structural and thermal finite element package. A single T800 node costs \$2,000, yet has the power of a \$10,000 386/1167 system. Isn't it time you considered porting your Fortran or C application to the transputer?

For further information, please call MicroWay's Technical Support staff at (508) 746-7341.

Micro Way

Quadputer™

*Mainframe Power
For Your PC!*

MicroWay's **Quadputer** is the most versatile multiple transputer board on the market today. Each processor can have 1, 4 or 8 megabytes of local memory. In addition, two or more Quadputers can be linked together with ribbon cables to build large systems. One MicroWay customer reduced an 8 hour mainframe analysis to 15 minutes with five Quadputers, giving him realtime control of his business.

World Leader in PC Numerics

P.O. Box 79, Kingston, MA 02364 USA (508) 746-7341
32 High St., Kingston-Upon-Thames, U.K., 01-541-5466
USA FAX 617-934-2414 Australia 02-439-8400 Germany 069-75-1428

sometimes dramatically improved by adjusting the contrast and other parameters.

On the press release, the TrueScan Models E and S were slightly faster than the OmniPage, with similar accuracy. On the Microbytes page, the OmniPage products were significantly faster, though its Mac version made more mis-

takes. Many of the errors made by both systems were missing spaces rather than misspellings (see figure 2).

On the third and fourth scans (the Adobe fonts and the laptop specs), the TrueScan models were faster. However, neither product produced acceptable output. Accuracy was poor, and although the labels fared less well than the numbers on the spec sheet, it would probably take longer to clean them up than to type them in from scratch.

The TrueScan systems were the clear winners on the multicolumn dot-matrix printout. On the income statement, the AT version of OmniPage finished first, though it made a few more mistakes than the TrueScan. The Mac OmniPage was the slowest and least accurate; the Model S also performed inadequately.

The legal contract and the three-column story produced some odd results. The AT version of OmniPage was the fastest on the contract, yet at the back of the pack on the news story. Finally, on the table, the Mac version of OmniPage fell apart in both time and accuracy. Again, some of this may have been attributable to the different scanners used.

OmniPage. The results depended on the particular page, although, overall, the TrueScan did better on spreadsheets and dot-matrix printouts. The Mac OmniPage might do much better with new drivers for the AppleScanner, which should be available now. Fiddling with scanner settings also helped.

Regarding ease of use, the OmniPage's reliance on Windows makes for a neatly visual interface during a scan, and I like the transitional editor, which lets you quickly see what you've scanned. But I found the TrueScan's menu system faster to use, although its inability to view scanned text was inconvenient. TrueScan's on-screen timer is also handy, and the Model E's ability to read documents in landscape orientation makes some tasks simpler.

OmniPage has the graphics command for choosing a partial-page area for scanning, the ability to read larger type, and the sophisticated Manual Galley command for dictating page layout. However, I was frustrated by its dependence on batch-mode formatting and conversion of documents in the AT version, and by the limited file formats available in the Mac version. Also, the accuracy of the Mac OmniPage/AppleScanner combination was less reliable.

None of the reviewed systems can efficiently handle pages with lots of fonts and odd-colored backgrounds, but all can do well on press releases and simple magazine clippings. My favorite is the TrueScan because of its accuracy, quick interface, landscape option, simultaneous image and text capture, and its many application file formats. I liked OmniPage's graphical depiction of work in progress, as well as its on-line tutorial.

Is this page recognition? Not exactly. Realistically, these products have just moved OCR into the age of clipping recognition. I still wouldn't trust the accuracy of poorly printed documents, important spreadsheets, or complex, small-type contracts to these systems, although they could help you grab chunks of text that you could then carefully check for spelling and logic. But both TrueScan and OmniPage represent a substantial leap forward toward complex document recognition. For grabbing clippings for desktop publishing, they are definitely practical. ■

Phillip Robinson, an editor for Virtual Information (Sausalito, CA), researches and analyzes trends in the computer industry. He is a contributing editor for BYTE and can be reached on BIX as "robinson."

• Despite ongoing— well, rampant—speculation about a new **laptop from Apple Computer**, Apple's John Sculley says the company's plans for a laptop are still hampered by **inadequate screen technology**. "I wish we had it now," Sculley said recently, but he added that a laptop is not a big part of Apple's plans for 1989. Sculley said the main

continued

12 B Y T E • FEBRUARY 1989

Figure 1: *The sample Microbytes text as originally input.*

The Last Word

The nod for fastest performance was between the Model E and the AT version of

(a)

• Despite ongoing— well, rampant—speculation about a new laptop from Apple Computer, Apple's John Sculley says the company's plans for a laptop are still hampered by inadequate screen technology. "I wish we had it now," Sculley said recently, but he added that a laptop is not a big part of Apple's plans for 1989. Sculley said the main (f)n~inu~d 12 B Y T E • FEBRUARY 1989 MICROBYTES ~

(b)

± Despite ongoing-well, rampant--speculation about a new **laptop from Apple Computer**, Apple's John Sculley says the company's plans for a laptop are still hampered by **inadequate screen technology**. "I wish we had it now," Sculley said recently, but he added that a laptop is not a big part of Apple's plans for 1989. Sculley said the main *continued*

12 B Y T E ± FEBRUARY 1989

(c)

*6 Despite *ongoingwell, *rampant-specula*tion about a new *laptop from Apple Computer, Apple's John *Sculley says the company's plans for a *laptop are still hampered by **inadequate screen technology**. "I wish we had it now," *Sculley said recently, but he added that a *laptop is not a big part of Apple's plans for 1989. *Sculley said the main *continued* *I

12 *B Y T E *- FEBRUARY 1989

Figure 2: *The sample Microbytes text as output by the Mac OmniPage (a), AT OmniPage (b), and the TrueScan Model E (c).*

OS/2 NEWS

A continuing report on advanced software for personal computers.

Get a free IBM OS/2-based version of Sidekick for Presentation Manager.

When you order IBM OS/2™ you'll receive Borland's Sidekick® free (while supplies last). Sidekick for Presentation Manager™ includes an easy-to-use planner, phonebook, calculator and notepad using the graphical interface. It gets you off and running with IBM OS/2 today.

Improved word processing software based on OS/2 is introduced by WordPerfect.

WordPerfect® has announced that a version of its best-selling word processor is now available for OS/2. The OS/2 version offers all the features of their popular MS/DOS® version while taking advantage of OS/2's capabilities, including multitasking. For additional information please call 1 801 225-5000.

Accountants get true multitasking via ACCPAC Plus and OS/2.

ACCPAC® Plus System Manager/2 is an accounting software package from Computer Associates International. It allows simultaneous execution of multiple accounting functions by using the protected mode of OS/2. This enables users to enter sales orders while concurrently performing payroll calculations and printing financial statements. In addition, thanks to the Virtual Memory Feature of OS/2, users can toggle between a number of applications without having to exit one program and load another. For additional information please call 1 800 531-5236.

Create exciting three-dimensional, dynamically developed maps using OS/2.

Mapmaking is easier than ever with MapViewer from Golden Software Inc. MapViewer uses OS/2 and Presentation Manager window screens to display two- and three-dimensional thematic maps. These maps can show population density or physical contours, and include shading. For additional information please call 1 303 279-1021.

Retailer begins use of OS/2 to monitor remote retail sales.

Host International has begun to use OS/2 to give computing capabilities to their individual concessions and to network shops with regional offices for daily downloading of sales and employee data. The internally developed system also provides for remote data entry, collection and reporting.

Developing graphics for OS/2 applications is made easy with Toolkit from Graphic Software Systems.

High-performance graphics on microcomputers are made possible with OS/2 Graphics Development Toolkit from Graphic Software Systems. This package supports all OS/2 features while maintaining source code compatibility with the DOS Graphics Development Toolkit. It allows dynamic loading plus workstation control. Functions for lines, arcs, polygons, circles, bars and advanced graphics are all part of the package. For additional information please call 1 503 644-6746.

Micrografx announces an easy way to port Windows applications to OS/2 Presentation Manager.

Micrografx® has introduced Micrografx Mirrors. This software development tool makes it easy to port any Microsoft Windows® application to the OS/2 Presentation Manager. It's currently being used successfully to port Micrografx Designer, Graph Plus, Draw Plus and Clip Art to OS/2. For additional information please call 1 800 272-3729.

Free OS/2 Application Guide available.

You can receive a 700-page OS/2 Application Guide that lists and describes over 800 identified applications for the OS/2 operating system. For a free copy of this guide call 1 800 IBM-2468, ext. 120.



Microsoft®

IBM®

NO ADDED CHARGE ON CREDIT CARDS

FOR COMPUTER & ACCESSORIES

EXECUTIVE

PHOTO & SUPPLY CORP.

HOURS: Mon. Tru. Thurs. 9AM Till 6PM, Fri. 9AM Till 1:30PM, Sun. 9:30AM Till 5PM, Closed On Sat.

CALL TOLL FREE: 1-800-882-2802

FOR FAX, TYPEWRITERS & DICTATION EQUIPT.

CALL TOLL FREE: 1-800-223-7323

IN N.Y. STATE CALL: 1-212-947-5290

LAPTOPS

SPARK BY DATAVUE



SPARK -EL

640K, 2-3.5 720K Disk Drives,

999.90

New! DATAVUE SPARK 1-Floppy Drive, & 1-20MB Hard Drive.....1769.95

MITSUBISHI
268L w/20MB Hard Drive.....2359.00
268L w/40MB Hard Drive.....CALL

EPSON
EQUITY LT w/2-Drives, Backlit Screen & Laplink Plus.....1045.00
EQUITY LT w/20MB Hard Drive1685.00

TOSHIBA (sold in Store Only)
T-1000.....CALL T-1200/FB CALL
T-1200HB.....CALL
NEW! T-1600.....CALL
NEW! T-3100E.....CALL
T-3200/T-5100.....CALL

ZENITH
184-1.....1439.00 184-2.....2199.75
Supersport 286 Model 20 w/20MB Hard Drive.....2965.75
286 w/40MB Hard Drive.....3399.75
386 w/40MB Hard Drive.....4199.00

NEC
PROSPEED 386.....CALL
ULTRALIGHT.....CALL
Multispeed HD.....LOW PRICE

SHARP
PC-4502 w/640K, 2-Floppy Drives & Backlit Monitor.....919.00

Laptop Accessories
WORLD PORT 2400 Modem/Fax.CALL
DICONIX Portable Printer.....299.95

DESKTOPS

COMPAQ



DESKPRO 286, 12MHz, 1.2 Floppy Drive, Seagate 40MB Hard Drive (40ms)2065.00
NEW! COMPAQ SLT/286 Portable w/40MB Hard Drive.....CALL

AST



AST PREMIUM 286
10 MHz, 512K, 1.2 Floppy Drive, Seagate 40MB Hard Drive (40ms)
1589.90

NEW! AST BRAVO 286 8 MHz, 1.2 Floppy, 40MB Hard Drive (40ms).....1255.00

EPSON
EQUITY 1+.....CALL

COMPATIBLES
IBM-XT Compatible, 1-360 Floppy Drive, 1-20MB Hard Drive.....725.00
IBM-AT Compatible, 12MHz, 512K, 1.2 Floppy Drive, Seagate 40MB Hard Drive (28ms).....1219.00
VENDEX Headstart III.....CALL

PRINTERS

EPSON



LQ-500
24 Pin, Narrow Carriage
180 CPS Draft, 60 CPS NLQ,
Tractor Feed Included
259.75*

LX-800.....170.99 EX-800.....369.75
LQ-850.....468.95* LQ-950.....489.00*
LQ-1050.....635.75* LQ-2550.....945.00
FX-850.....339.95 FX-1050.....449.95
*Price After Rebate

PANASONIC
KX-P 1191, 235.75 KX-P 1181, 175.75
KX-P 1124.....CALL
PANASONIC Laser Printer.....CALL

TOSHIBA (Sold in Store Only)
NEW! Expresswriter 311.....CALL
NEW! 321SL Color.....CALL
341SL.....CALL 351 SX.....CALL

NEC
NEC 2200.....339.00
NEC P5200.....499.95
NEC P5300.....649.95
NEC LC-890 Postscript Laser.....3089.00

OKIDATA
OKIDATA 320.....339.00
OKIDATA 390.....469.95
OKIDATA 393.....1019.00

STAR
NX-1000.....169.90 NX-1000C.....189.00
NX-1000 Rainbow.....229.00

PRINTER SALE!
H.P. Laserjet II w/Toner.....CALL
APPLE Imagewriter II.....439.00

HARDWARE

intel



INTEL 80287-8.....205.00
NEW! INTEL Above Board Plus.....386.00
INTEL 386PC Piggyback w/IMB.....257.00
NEW! INTEL Visual Edge.....429.00
NEW! Logitech Scanman.....84.95
NEW! Logitech Scanman.....189.00
DFI HS-3000 Scanner.....189.00
STB VGA Extra.....179.95
PARADISE VGA Plus.....257.00
NEW! PARADISE VGA Plus 16.....299.90
ATI VGA Wonder.....269.95
MICROSOFT Mouse.....99.95
NEW! NEC Multisync IIA Monitor.....CALL
ZENITH Perfect Monitor.....CALL
SONY 1302 Monitor w/Stand.....659.00
SONY 1302 VGA Monitor.....499.00
PLUS 20MB Card.....LOW PRICE
MOUNTAIN 30MB Card.....349.00
TOSHIBA 3 1/2" 720K Drive w/Kit.....85.00
EVEREX 1200B Modem.....CALL
EVEREX Fax Card.....309.00
COMPLETE PC Fax 4800.....235.00
QUADRAM JI Fax Internal 4800.....179.00

DISKETTES
maxell



MAXELL MD-2D.....9.49
MAXELL MD2-HD.....18.99
MAXELL MF2-HD 1.44.....CALL

DATA CARTRIDGES
3M DC Cartridges.....CALL
IOMEGA 5 1/4 & 3 1/2".....CALL

Laser Font Cartridges
HP Pro Collection.....235.00
IQ Engineering Cartridge.....375.00

Laser Toner Cartridges
HP Laser II Toner.....CALL
PARASONIC Toner Kit.....CALL
OKIDATA Laserline Toner.....CALL
NEC 800 Toner.....CALL

SOFTWARE

WORDPERFECT.....224.95
NEW! SAMNA AMI.....93.00
XY Write w/Al A Carte.....215.95
WORDSTAR Pro.....Low Price
GRAMMATIC III.....48.99
INSIGHT Laser Control.....77.00
BTRISPEAK Fonts.....CALL
MICROGRAFX Designer.....425.00
XEROX Ventura Publisher 2.0Low Price
ALDUS Pagemaker.....445.00
HARVARD Graphics Screenshow.89.95
GEM Artline.....269.75
ADOBE Illustrator.....329.95
PFS First Publisher.....69.00
PROCOM Plus.....42.95
PC Anywhere III.....74.99
SMARTCOM III.....139.00
NEW! LUICID 3D.....59.00
MICROSOFT Excel 2.1.....225.00
LOTUS 1-2-3.....CALL
NOTA BENE 3.0.....235.00
Q & A.....CALL
ASK Sam.....165.00
D/Base IV.....Low Price
DATEBASE.....CALL
PARADOX 3.0.....CALL
FRAMEWORK III.....399.00
INTUITU Quicken.....31.95
MATHSPEAK Your Money 5.0.....115.95
DAC Easy Accounting 3.0.....57.00
SOLOMON Basic Accounting.....149.95
ONE Write Plus.....125.00
NLO Will Maker.....30.95
NLO for the Record.....31.95
FASTBACK Plus.....97.00
SPINRITE.....48.99
FASTRAX.....32.95
386 MAX.....54.75
DELTA Direct Access.....50.95
SPINAKER Resume Kit.....32.00
TRAVELING Software Viewlink.....85.95
FLASH 6.0.....35.95
NORTON Advanced Utilities.....74.95
FUNK Always.....84.50
SYSTEM Sleuth.....84.95
BORLAND Turbo Pascal.....93.50
BORLAND Turbo C.....93.50
MACE Gold.....74.99
MACE Nvelope.....26.95
MICROPROSE F-19.....39.99
ZENOGRAPH Pixie.....107.95

FAX MACHINES

PANAFAX



UF-140.....CALL UF-150 IN STOCK
UF-250 IN STOCK UF-260 IN STOCK

SHARP
FO-220.....CALL FO-300.....CALL
FO-420.....CALL FO-550.....CALL
FO-700.....CALL FO-800.....CALL

CANON FaxPhones



FaxPhone 8.CALL FaxPhone 15 CALL
FaxPhone 20 CALL FaxPhone 25 CALL
FAX 1100.....CALL FAX 225.....CALL
FAX 270.....CALL FAX350.....CALL
FAX 630.....CALL FAX 705.....CALL

RICOH
FAX-25E.....CALL FAX-35.....CALL
FAX-65E.....CALL FAX-75E.....CALL

MURATA
M-1200.....599.90 M-1600.....699.90

PANASONIC
KX-F 100A.....CALL KX-F 120.....CALL

TOSHIBA Price Break
3300.....859.90 3700.....1199.90
Model 30100.....759.90
NEW! 3600.....CALL

SANYO
515H.....IN STOCK SF-200 IN STOCK

BROTHER
FAX 60 w/Answering Machine.....759.90
FAX 175.....CALL

FAX PAPER
8 1/2"x98".....49.95 8 1/2"x164".....59.90
8 1/2"x328".....74.95
FAX Cleaning Kit.....29.95

TYPEWRITERS & Word Processors

SMITH CORONA



PWP-60.....469.90
PWP-40IN STOCK PWP-80IN STOCK
NEW! PWP-100.....IN STOCK
XL-1000 Typewriter.....Special 119.90
XL-2500.....CALL XD-5500.....CALL
XD-7500.....CALL XD-9500.....CALL

PANASONIC



KX-W 1500 Word Processor. IN STOCK
KX-R 320.....CALL KX-R 330.....CALL
KX-R 340.....184.90 KX-R 350.....219.90

BROTHER



WP-55 Word Processor.....IN STOCK*
NEW! WP-490.....CALL
AX-26.....CALL AX-28.....CALL
*Free Spreadsheet Program w/Purchase of WP-55 Word Processor

Dictation Equipment

OLYMPUS PearlCorder



L-200.....129.90 S-907.....35.90
S-911.....59.90 S-930.....99.90
T-1010 Transcriber.....169.90
S-804.....CALL S-810.....CALL
T2000.....CALL S-2020.....CALL

PANASONIC
RN-15.....129.90 RN-36.....179.90
RN-89.....79.90 RN-105.....29.90
RN-115.....39.90 RN-125.....53.90
RR-800.....179.90 RR-970.....249.90
RR-980.....179.90.....279.90

SANYO
TRC-6100.....CALL TRC-5680.....79.90
TRC-2550.....149.90
TRC-5200.....229.90 TRC-5020.....179.90
TRC-4100.....227.90 TRC-4141.....178.90
TRC-8000A.....227.90 TRC-8010A.....165.90
TRC-8700.....239.90 TRC-8070.....195.90
TRC-9100.....239.90 TRC-9010.....199.90

SONY
M-100B.....219.90 M-740.....35.90
M-750V.....49.90 TC-M5000EV.....369.90
BM-12.....CALL BM-17.....CALL
BM-60.....CALL BM-500.....CALL
BM-75.....CALL BM-80.....CALL
BM-81ST.....CALL BM-820.....CALL

NORELCO
585.....99.90 592.....119.90
NT-11e.....134.95 NT-V.....199.95
NT-VI.....219.90 NT-VII.....247.90
MC-11.....164.95 MC-IV.....119.90
295.....287.90 505.....319.90
510.....399.90 805.....629.90
MC-3000.....299.90 MC-4000.....379.90
2505.....399.90 2510.....334.95

COPIERS

Canon



PC-3.....349.90 PC-5.....CALL
PC-5L Legal Size.....529.90
PC-6.....CALL PC-6RE.....CALL
NEW! PC-7 Zoom Copier.....909.90
Black Cartridges.....79.95
8 1/2x11 Paper (5000 sheets).....49.50

CALCULATORS & DATABANKS
HEWLETT PACKARD
HP-10B Business.....38.45
HP-12C Financial.....59.90
HP-14B Business.....58.90
HP-17B Business.....75.90
HP-19B Business Consultant II.....125.90
HP-20S Scientific.....39.90
HP-22S Algebraic Scientific.....43.90
HP-27S Scientific.....74.95
HP-28S Advanced Scientific.....162.90
HP-32S RPN Scientific.....52.95
HP-41CV.....119.90 HP-41CX.....169.95
HP-42S RPN Scientific.....88.90
HP Infrared Printer.....99.90

POSIX
ORGANISER II-XP.....198.90

SHARP
OZ-7000 WIZARD.....IN STOCK
EL-1197 IV 10-Digit Tax Function.49.90
EL-2197 12-Digit Tax Function.....57.90
EL-6230 Auto Dialer.....39.90
EL-6250D Dial Master.....53.90

CASIO
SF-3000/18K Digital Diary.....69.90
SF-4000 32K Digital Diary.....89.90
IF-8000 Digital Diary.....119.90
NEW! SF-7500 Digital Diary Clock189.90

TELEPHONES

Panasonic



Feature Telephones
KX-T 2335.....32.90 KX-T 2365.....55.90
Multi-Line Phones
KX-T 3122.....56.90 KX-T 3145.....67.90
KX-T 3155.....75.90 KX-T 3170.....139.90

INTEGRATED PHONES
KX-T 2385.....62.90 KX-T 2630.....105.90
KX-T 2429.....135.90 KX-T 2430.....108.90
VA-8035.....149.90

Answering Machines Specials
KX-T 1412.....59.90 KX-T 1418.....69.90
KX-T 1423.....65.90 KX-T 1424.....69.90
KX-T 1427 LCD w/Time Announce109.90
KX-T 1600.....69.90 KX-T 1720.....109.90

CORDLESS PHONES
KX-T 3000.....119.90 KX-T 3807.....59.90
KX-T 3823.....70.90 KX-T 3824.....89.90
KX-T 3832.....93.90 KX-T 3880.....125.90
HP-12900 w/2-Keypads.....123.90
KX-T 4200 w/Answering Machine.....145.90

Freedom Phone
FF-1700 Cordless "Top Rated"109.90

Gabra
AN-8518 "Top Rated".....139.90
AN-8521 Cordless Machine w/Answering Machine.....147.90
CA-8073S 2-Line Cordless.....147.90

PHONE-MATE
9550.....119.90 9750.....147.90
7650.....129.90

SONY
SPP-50.....89.90 SPP-80.....119.90
SPP-150.....179.90 ITA-550.....148.90

AT&T
420 w/Speaker "Top Rated".....67.95
422 2-Line Phone w/Speaker.....99.95
480 w/Speaker "Top Rated".....88.95
5310 Cordless.....153.90

OUR GUARANTEE: Defective goods will be replaced or repaired if returned within 10 Days in original packing, mint condition, blank warranty card, detailed letter of explanation & copy of invoice. No return privilege on software. If found defective, we will advise customer how to consult manufacturer for warranty service. For Customer Service: Please Call (212) 947-5295. Not Responsible for typographical errors. We reserve the right to limit quantities.

TO ORDER BY MAIL: Please send money order or certified check for UPS shipment on most items. Personal check delays your order by 15 days.
Shipping & Handling: Handling Charge; 2% plus 5.95. Shipping Charge: 0.65 per lb. Estimate minimum shipping 5.95. Total charge at time of order. Shipping & Handling charges are not refundable.
INQUIRE about NEXT DAY AIR or 2nd DAY AIR Shipment. N.Y. State Residents add TAX.

EXECUTIVE
PHOTO & SUPPLY CORP.

MAIL ORDER: Dept BY, 120 West 31st Street, N.Y., N.Y. 10001 (Tel. 1-212-947-5290)
MANHATTAN STORE: 120 West 31st Street, N.Y., N.Y. 10001 (Tel. 1-212-564-3592)
SCARSDALE, NY STORE: 455 Central Ave. (Scarsdale Plaza) SCARSDALE, N.Y. 10538 (Tel. 1-914-723-1331)
N.Y.C. Consumer Affairs License Number: 800193

Circle 103 on Reader Service Card



Mac Goes Fax

With fax modems for the Mac, sometimes the more you pay, the less you get

Don Crabb

Fax machines were once primarily tools that big businesses used to send a hard copy of important documents abroad via telephone lines. The units cost more than \$2000 and were often finicky and unreliable. But the CCITT's Group 3 standard for fax communications has largely changed all that. Today, fax machines have become so popular and so inexpensive that even lifestyle vendors like The Sharper Image are carrying them in their catalogs. You can now buy a good-quality stand-alone fax machine for less than \$800.

The next step in this fax revolution would seem to be the personal computer fax modem. Fax modems strip off the scanning and printing hardware of a stand-alone fax machine, along with the phone handset and other phone hardware, reducing a fax machine to its bare essentials. Functions such as telephone dialing and management are handled by software that also prepares a document for transmission. Because personal computer fax modems eliminate some of a fax machine's hardware, they're generally cheaper to buy and easier to set up.

While fax modems for the IBM PC have been around for some time, reliable units for the Mac have appeared only recently. I tested three external units for this review: Abaton's InterFax, Apple Computer's AppleFax, and the FaxSTF from STF Technologies. I also looked at



BackFax, a replacement program for the AppleFax software that adds background-mode operation to the unit's capabilities (see the text box "AppleFax Extender" on page 208F).

Fax: Who Needs It?

When I first started looking at fax modems for the Macintosh, I was unimpressed. Fax modems seemed to be a product in search of a need. The devices aren't a viable replacement for full-fledged fax machines, since they lack both a scanner and a printer. If you want to turn your Mac into a fax workstation capable of the same kinds of operations that a stand-alone fax machine provides, you must have a scanner capable of at least 200 by 100 pixels per inch (that's considered standard resolution by Group 3 standards—high resolution is 200 by 200 pixels) and a printer capable of printing at that resolution.

If you add the price of a medium-resolution flatbed scanner (\$600 to \$1000) and the price of a 24-pin dot-matrix

printer (like the Apple Imagewriter LQ at \$1300) or a low-priced laser printer (like the Apple LaserWriter IISC at \$2900) to the price of a fax modem (\$495 to \$699), you're talking about a fax workstation that costs \$2395 to \$4599, not including the cost of the Mac. That's well above the cost of a stand-alone fax machine (\$799 to \$1600).

The comparison becomes more odious when you consider that of the three modems I tested for this article, only one, the Abaton InterFax, came with software that allowed unattended transmission and receipt of faxes in the background.

On the other hand, fax modems let you store an image electronically for editing with a paint program. You also get better-quality output, for two reasons. Most stand-alone units generate printouts on low-quality thermal paper that can't compete with a laser printer's. And unlike stand-alone machines, fax modems don't require printing a file and scanning it

continued

| Name | InterFax | AppleFax | FaxSTF |
|------------------------|--|---|---|
| Type | Fax/data modem | Fax modem | Fax modem |
| Company | Abaton 48431 Milmont Dr. Fremont, CA 94538 (800) 444-5321 | Apple Computer, Inc. 20525 Mariani Ave. Cupertino, CA 95014 (408) 996-1010 | STF Technologies, Inc. 1817 Main St. P.O. Box 247 Higginsville, MO 64037 (800) 426-1679 |
| Features | Transmits CCITT Group 3 fax at 4800 and 2400 bps, CCITT V.22 (1200 bps), V.21 (300 bps), and Bell 103 (0-300 bps) and 212A (1200 bps); command-compatible with Hayes Smartmodem; sends and receives in background mode; supports Group 3 polling | Transmits CCITT Group 3 fax at 9600, 7200, 4800, and 2400 bps; also supports CCITT Group 2 fax; transmits binary and text files between AppleFax units at 9600 bps via proprietary file transfer scheme; polls other AppleFaxes | Supports CCITT Group 3 fax at 4800 and 2400 bps; has background-receive capability |
| Size | 5¾ × 8 × 1¼ inches | 7⅞ × 4¾ × 2 inches | 6 × 3½ × 1 inches |
| Hardware Needed | Mac Plus or higher; 1 megabyte of RAM | Mac Plus or higher; 1 megabyte of RAM | Mac Plus or higher; 1 megabyte of RAM |
| Software Needed | System and Finder 5.0 or higher | System and Finder 5.0 or higher | System and Finder 5.0 or higher |
| Documentation | 147-page hardware manual; 141-page software manual | 191-page user's guide | 73-page user's manual |
| Warranty | 1 year parts and labor | 90 days parts and labor | 90 days parts and labor |
| Price | \$495 | \$699 | \$695 |
| | Inquiry 851. | Inquiry 852. | Inquiry 857. |

before transmitting it. Finally, fax modems are convenient. You don't have to walk down the hall and wait in line for the fax machine or babysit multipage documents that might get stuck in the feeder.

After spending a month testing fax modems, I think they're best suited for offices that have already invested in a Mac, a laser printer, and perhaps a scanner, and that send and receive a lot of hard-copy fax materials that have been created on the Mac. If all you want to do is send hard-copy faxes, a fax modem system is overkill. And for many electronic files, a standard data modem may be sufficient.

A Quick Rundown

None of the fax modems I tested are cheap, but the Abaton unit, at \$495, is the least expensive of the group. Next comes the FaxSTF at \$695, followed closely by the AppleFax at \$699. The prices include the power supplies, serial connection cables, twisted-pair flat phone wire, and software. The FaxSTF also includes a handy, zippered, nylon carrying case.

The AppleFax modem transmits fax images at up to 9600 bps, considerably

faster than the InterFax and FaxSTF units, which are limited to 4800 bps. But the InterFax also includes a 1200-bps Hayes-compatible data modem. Apple has developed a proprietary scheme that lets you use the AppleFax's 9600-bps half-duplex fax modem to transmit binary and text files, but it works only with other AppleFax modems. The FaxSTF doesn't offer any standard data communications capability.

While all three devices let you store incoming faxes in a proprietary format or to the Clipboard for use with paint programs, none supports MacDraw PICT, Encapsulated PostScript, resource PICT, or other popular file formats, and none provides any image editing or manipulation capabilities.

Each unit comes with a fax-mail application that lets you create, preview, send, receive, review, and manage fax documents. All the applications let you create fax documents from within another application, since they provide Chooser resources that allow the application to be printed to the fax modem or saved to disk and previewed.

The Abaton InterFax includes a control-panel resource. This controls the

sending and receiving of faxes in background mode and lets you send a fax during a voice-initiated call and then resume your conversation when the transmission finishes. The InterFax's background send/receive does not require MultiFinder, although it's MultiFinder-friendly. The FaxSTF can receive background faxes but not send them.

The AppleFax software doesn't allow either background sends or receives unless you buy Solutions' BackFax program. Neither the AppleFax nor the FaxSTF supports fax transmission during voice-initiated calls.

One handy feature of the InterFax is polling. When you set polling on, the InterFax will query the receiving fax machine or fax modem to determine if any faxes are waiting to be sent to you. If so, it permits them to be sent immediately, saving time for both the sender and the receiver. The AppleFax has a modified version of polling that works only with other AppleFax modems (not with stand-alone fax machines). The FaxSTF doesn't support polling.

Each fax application includes fairly extensive management facilities for the

continued



Our standards are the toughest part of our 3.5" diskette.

We've got you covered. The rigid plastic jacket of our 3.5" Micro Diskette is molded to our own specifications for unsurpassed protection. And, our clipping level is 44% higher than industry standards. Call 800-343-4600 for the name of your nearest BASF supplier.

Depend on it.



BASF

AppleFAX Extender

One of the biggest omissions in the AppleFAX software is the lack of a background sending and receiving capability. Fortunately, Solutions' BackFAX program has addressed the problem. Solutions has a reputation for quality software, like SuperGlue, SmartScrap, The Clipper, and Glue. In the limited tests that I made, BackFAX lived up to that reputation.

BackFAX is written strictly for the AppleFAX modem, transforming an AppleFAX-equipped Mac into an automated fax station that will send and receive Group 3 faxes while letting the Mac do other work in the foreground. BackFAX replaces the AppleFAX software that Apple supplied with the modem. Like Abaton's InterFAX software, BackFAX can work in the background without MultiFinder.

With BackFAX, you also can create special cover pages for any fax message or group of messages you're sending (this is something none of the other packages offers). These cover pages can include information that identifies the sender, the time and date of the transmission, the number of pages in the fax, the subject of the fax, and any special

delivery instructions. Because the cover page is a fax document itself, it can also include graphical information to help distinguish it from other faxes that you receive.

BackFAX also includes fax message and phone management capabilities similar to those in the AppleFAX software that it replaces. The program includes its own Chooser resource, MailSaver, which converts documents to fax format and can send your documents once they're converted. MailSaver's send screen looks like the Font/DA Mover and is easy to learn.

If you already have an AppleFAX, BackFAX is worth the extra \$245. Otherwise, the Abaton InterFAX is a better buy. For \$495, it includes background/receive software that supports message and phone management facilities like those in BackFAX. In contrast, the AppleFAX/BackFAX combination costs \$944, comparable to the price of many stand-alone fax machines.

BackFAX is published by Solutions International, under license from Solutions, Inc. The company can be reached at 30 Commerce St., Williston, VT 05495, (802) 658-5506.

faxes that you send and receive, along with phone capabilities that control the dialing of remote faxes, the use of pulse or tone phones, and the management of on-line phone directories. None of the programs is superior at fax and phone management, although I did find the Abaton software marginally easier to learn and use.

Technical Details

I've summarized the specifications and features of each fax modem in the table on page 208D. Unfortunately, the more technical information was available only from Apple; little additional information was available for the Abaton or STF units.

The AppleFAX modem includes an 8-bit 65C112 microprocessor that uses a 1.8432-MHz clock. The modem uses the processor to direct and control logic flow, configure operating modes (fax or data), decode and execute host instructions, and direct and buffer data between the host and the modem's serial channel controller (SCC). The processor addresses 8K bytes by 8 bits of RAM that's

contained in a single IC and is used as a data buffer between the host and the device (fax or another Mac) to which it's connected.

In addition to the RAM, the AppleFAX also includes 32K bytes of 8-bit ROM that contains control firmware used by the processor to execute AppleFAX modem routines. The AppleFAX's SCC is also controlled by the 65C112 microprocessor. The SCC converts data from serial to parallel and from parallel to serial, depending on memory needs. The SCC contains two bit-oriented serial ports. One port is an asynchronous one to the programmable array logic in the AppleFAX; the other is a synchronous port to the AppleFAX's internal data pump.

The AppleFAX includes two external interface ports. One is used by the host computer when the AppleFAX is under host control; the other is a pass-through port that lets you connect other serial devices (e.g., a data modem) to your Mac. This additional serial port means that you don't have to give up your Mac's modem port to use the AppleFAX modem. It also saves you from purchasing a serial

switch box if you already have both Mac serial ports in use.

The back panels of all three modems include RJ-11 telephone jacks for connection to your telephone line and your phone handset. Each modem also includes a back-panel power socket for connection to the supplied transformer/power supplies and an on/off switch. The FaxSTF, however, does not have a power switch; plugging in the unit turns it on.

The front panels are devoted to standard modem status lights for the InterFAX, modified status lights for the FaxSTF, and green and yellow power and mode lights for the AppleFAX. The AppleFAX also includes a mode-select switch in the front for toggling between normal fax/modem mode and pass-through mode (enabling the pass-through serial port). The AppleFAX provides a sliding speaker-volume control on the side; the other two modems lack this feature.

The power transformers for the InterFAX and the FaxSTF are modest, but the Apple transformer is a large brick that's almost as big as the modem itself. Whether or not its size indicates a more robust power supply is hard to tell, but the transformer makes the unit heavy, which may be a factor if you plan on transporting the device.

Put to the Test

I tested each modem by connecting it to two different kinds of systems: 8-megabyte color Mac IIs and 2-megabyte Mac SEs. I used System 6.0.2, Finder 6.1, and the other system software from the 6.0.2 System Tools during testing. During my first round of testing, I kept only the desk accessories, fonts, INITs, and cdevs supplied with the Apple System.

Each modem comes with its own start-up document (INIT) that's installed into the System Folder. Once I established that all the basic software accessories wouldn't cause any problems with the modem INITs or software, I reinstalled my usual mix of multiple cdevs, fonts, and desk accessories, controlled by MasterJuggler. But when I retested each modem with this system software, I ran into two problems with the InterFAX and its INIT: The Abaton INIT was incompatible with two other INITs in my usual system mix: the AutoMac III macro system and the MenuClock 101 menu bar clock.

Other than these incompatibilities, I was able to install and use the start-up documents of each fax modem in my normally crowded System Folder without a

continued

Knowledge, Experience & Expertise

your most valuable resources.

HYPertext FRONT-ENDS

Now available on the IBM PC!

KnowledgePro® is a tool for "explaining things" using a computer. It combines HYPertext and EXPERT SYSTEM technologies in a high-level language to let you write stand-alone applications or add an intelligent, aesthetic interface to your existing programs.

KnowledgePro stores knowledge in natural "chunks" called topics. It lets non-programmers communicate complex information using simple commands like SAY, ASK, IF, DO and PICTURE.

KnowledgePro lets you integrate hypertext, rules, math, lists, and logic quickly and easily. With our Database Toolkit you can read Lotus 123 and dBASE III files. The Graphics Toolkit lets you define hypergraphics using PC Paintbrush images. The VideoDisk Toolkit provides complete control of interactive laser video.

KnowledgePro reads, writes and searches text files. You can include routines written in other languages and call other programs.

INTELLIGENT MANUALS

EXPERT SYSTEMS

KnowledgePro runs on IBM PC XT, AT and PS/2 compatibles with 640k. It costs \$495 plus \$8 shipping (\$58 foreign). There are no run-time charges, so you don't have to pay more to distribute applications. The Database, Graphics and VideoDisk Toolkits cost \$49, \$89 and \$249 respectively. KnowledgeMaker, our induction system for creating rules from data, costs \$99. Stock Expert, a system for the personal investor, costs \$249. A working demonstration system, with a 100 page manual, is available for \$30 plus \$5 shipping (\$8 foreign) with credit toward purchase of the full system.

Circle 145 on Reader Service Card

KnowledgePro®

A tool for communicating knowledge

by Bev & Bill Thompson

from



For product literature, review reprints or to order:

Call 518-766-3000

(FAX 518-766-3003)

Amex, MC, Visa, COD or send check to:
Knowledge Garden Inc., 473A Malden Bridge Rd.
Nassau, NY 12123, USA.

New York residents please add 7% sales tax.

Join us on CompuServe (GO PCVEN user option #8)

KnowledgePro is a trademark of Knowledge Garden. IBM, dBASE III, Lotus 123, CompuServe and PC Paintbrush are trademarks of their respective corporations. Photo Tcherevkoff ©

hitch. I removed AutoMac III and MenuClock 101 for the duration of my second-round tests.

The AppleFax and InterFax software functioned properly during my tests. But I encountered intermittent problems with the FaxSTF software, especially when I used it with MultiFinder. The error dialogues ranged from Error ID = 7 ("A Facsimile error has occurred. The FaxSTF modem could not be found.") to a problem in which the program quit without explanation and returned to the Finder. These errors occurred randomly with the FaxSTF application, with both my bare-bones test System and my cdev/INIT/desk accessory-loaded System.

Font Problems

One of the tricks of sending clear faxes through the Mac is to have the appropriate fonts. The rule to remember is the 3-times rule. Faxes that are converted from documents with 12-point type must have that same typeface's 36-point size installed in the System, or the fax conversion will take place with a scaled version of the 12-point font—with less than impressive results. Each document that you prepare for faxing must have at least two versions of a font installed in the System: the actual screen font, and a font three times that size (the 3-times rule). As long as you have the larger fonts installed, your faxed documents will be received at their highest possible resolution.

Apple solves the 3-times-rule font problem by including letter-quality fonts in sizes up to 72 points for the Symbol, Times, Helvetica, and Courier fonts. Since Apple no longer licenses these letter-quality fonts to other vendors, that can be a problem for users of the InterFax and FaxSTF. Abaton came up with a decent solution by offering two non-Apple fonts, SWA Swiss and SWA Dutch (which are roughly comparable to Helvetica and Times, respectively), in sizes from 9 to 72 points. If you use these fonts for your fax documents, the resulting resolution is much greater.

Before Apple's licensing changes, the FaxSTF included the Apple letter-quality fonts. Unfortunately, STF Technologies has not included substitutes for these missing letter-quality fonts, so documents sent using 12-point Helvetica, for example, will be faxed as a scaled 36-point Helvetica, with considerably less resolution than if the 36-point font size were installed in the System.

Performance Testing

I ran some informal performance tests with these three modems. The tests con-

sisted of sending and receiving three different documents: a scanned page from the AppleFax manual, a MacPaint screen shot of ParcPlace's Smalltalk-80 system, and a text document created using Ashton-Tate's FullWrite Professional. None of the modems had any problems converting these files into standard- and high-resolution fax images, and none of the modems had any problems sending or receiving the images.

I am convinced that these products have a legitimate niche alongside stand-alone fax machines.

There were some differences in the times necessary to send and receive documents, however. The best performance was from AppleFax to AppleFax, which was 30 percent faster than the other units. I then tested the modems by sending these same documents to a local 9600-bps Sharp Group 3 stand-alone fax machine and to the same model fax machine located in San Francisco. Again, the AppleFax was 25 percent to 30 percent faster than the other units.

But while I expected the 9600-bps AppleFax to be consistently faster in all the tests, that wasn't the case. Often, line noise caused the AppleFax to fall back to 4800 bps, negating its speed advantage. However, you wouldn't know this unless you timed the transmission, since none of the modems provides any indication of the speed at which it's transmitting. If my tests are any indication, you probably shouldn't let claims of speed influence your decision to buy a fax modem. Price, flexibility, and good software are more important.

Recommendations

After working with these products, I'm convinced that they have a legitimate niche alongside stand-alone fax machines. Of the three units, I rate the Abaton InterFax the highest. It costs the least at \$495, and it also provides a fine 1200-bps Hayes-compatible data modem capa-

bility. Although it was slower than the AppleFax in some tests, it's as fast as the FaxSTF. Also, its software is marginally the best for managing incoming and outgoing faxes.

The InterFax also includes the ability to send and receive faxes in the background (without the need for MultiFinder), so you don't lose your machine while faxing (neither the AppleFax nor the FaxSTF could both send and receive in background mode). And Abaton includes two letter-quality fonts, in sizes up to 72 points, that look nice when received by stand-alone fax machines.

The AppleFax is a good fax modem, but it suffers from substandard software that doesn't allow background sending and receiving. You can buy BackFax to add background capability to the AppleFax, but that brings the total cost to \$944. For \$699, the AppleFax should include that software as part of the package, especially since the manual touts the modem's role in the AppleFax workstation.

The AppleFax does have the added utility of exchanging Mac text and binary files with other AppleFaxes at 9600 bps. Apple also includes the Imagewriter letter-quality fonts in sizes to 72 points, for sharp-looking faxes.

Unfortunately, the AppleFax has also had its share of hardware problems. At press time, Apple had temporarily suspended shipment of the AppleFax due to a ROM problem that reportedly kept the device from working with some private branch exchanges and older Group 3 fax machines. The unit I tested seemed to function fine.

The FaxSTF isn't a polished product; it lacks several important details that would make it substantially better. The manual is almost impossible to read because the typeface is so minuscule, and it's missing substantive details about the fax hardware. The foot-long serial cable is too short. The modem doesn't have any letter-quality fonts. And the software has the weakest management capabilities of the three units and doesn't allow background sends. On top of all that, at \$695, the FaxSTF is also expensive. The unit's saving grace is its size. It's the smallest and lightest fax modem I tested, which may make it a good companion to a Mac laptop when one arrives. ■

Don Crabb is the director of laboratories and a senior lecturer for the computer science department at the University of Chicago. He is also a consulting editor for BYTE. He can be reached on BIX as "decrabb."

"The printer that changed my life."

"I remember when the ACCEL-500™ arrived as if it were yesterday. Because it was.

It all started innocently enough. The boss questioned my decision to buy the ACCEL-500 instead of the leading 24-pin dot matrix printer.

With ACCEL-500's SelectDial™ fingertip control, I put the handsome new printer through its paces. Zooming through paper handling and setup options. Snapping in IntelliCard™ modules to emulate every printer and font style he could think of. From 480 cps draft mode to high resolution color graphics, from 6-part forms to sheet-fed envelopes, ACCEL-500 demonstrated a versatility previously the province of vegetable slicers and dicers.

The boss beamed, shook my hand, and left me to face a hostile crowd of jealous, resentful co-workers. I made a successful break for this broom closet. Where I'll remain until they give up and go home.

Good thing the ACCEL-500 runs unattended, around the clock. I could be here for days."

ACCEL-500™

Advanced Matrix Technology

765 Flynn Road, Camarillo, CA 93010

(800) 992-2264 (805) 388-5799

Circle 32 on Reader Service Card



One Call Does It All*

*Systems To YOUR Specifications

If you like the idea of buying quality computer components but hate dealing with uninformed order takers, you're ready for the alternative source for quality, value, and performance in computer systems: The On-Line Store.

Why compromise? The On-Line Store's in-house technicians know the right questions to ask. They'll custom configure a system to fit your exact needs.

With your order, you'll receive unlimited access to On-Line's extensive BBS with literally hundreds of free programs, as well as toll-free access to On-Line's technical support line.

From the individual PC to the multi-tasking environment one call does it all—at the On-Line Store.

PC/WORKS



**NEW!
PCX
MULTI-
LINE**



VOICE/MAIL SYSTEM

Everyone's talking about the new multi-line version of PCX Voice/Mail Telemarketing System.

The single line version of PCX was just awarded PC Magazine's *Editor's Choice* in January (under its parent name, Bigmouth) and we fully expect the multi-line version to carry on the family tradition of earning top honors for high flexibility and low price.

With hundreds of features such as call routing, in- and outbound telemarketing and private mailboxes, PCX can be customized to fit your particular needs.

With the multi-line version, you can increase your capabilities as your needs grow. Upgrade from one to two lines (ask about full value trade-ins) and add on additional units to accommodate up to 16 phone lines.

Single Line Version **\$269** Multi-Line Version **\$699**

SYSTEMS BUILT TO YOUR SPECS



**30 MB
HARD DRIVE SYSTEM
286/AT**

Now Only **\$995**

- 80286 Processor • IBM/OS2 Compatible
- 80287 Co-Processor Slot • EGA/VGA Card

**40 MB HARD DRIVE SYSTEM
PS/2 STYLE**

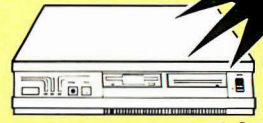

- MHz Indicator Light
- Low Profile Streamlined Case
- Intel 80286 • IBM/OS2 Compatible

\$1295

**NEW!
Slim
Design**

**65 MB
386/TOWER
CASE SYSTEM**

- Novell/UNIX/XENIX/LAN
- 1 MB RAM Expand to 10 MB

\$1995

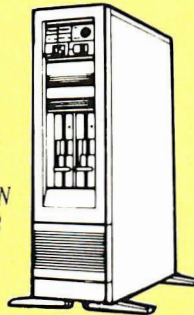

PORTABLES TO GO

PORTABLE 286/12



\$995

286/12 MHz, 40 MB, 512K \$1595
386/20 MHz, 65 MB, 1 MB 2595

**Ask
About
Our
Specials**

**65 MB HARD DRIVE
MICRO
TOWER**

- High Speed Disk Access
- IBM/OS2 Compat. • 4 Drive Cavities • Intel Processor

\$1495

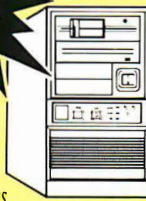

**NAME BRAND
LAPTOP**

Now Only **\$775**

- Lightweight • Battery/AC
- IBM Compat. • LCD Display

20 MB Hard Drive Option CALL

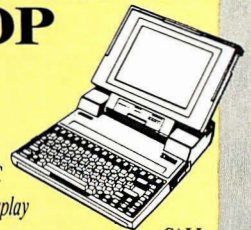

286 SYSTEM SPEED INDEX

10 MHz

0 Wait
11.9
1 Wait
10.2

12 MHz

0 Wait
15.3
1 Wait
11.9

16 MHz

0 Wait
18.7
1 Wait
15.3

20 MHz

0 Wait
23.4
1 Wait
18.7

To visit us on CompuServe's Electronic Mall, type GO OS.

Call Our Revolutionary 24-Hour Multi-Line Voice/Mail Telemarketing System To Order Today

805 / 650-0188



BBS 805/650-0193
FAX 805/650-0195
CUSTOMER SERVICE 805/650-0188
3037 Golf Course Dr., Ventura, CA 93003



Your Data Communications System Specialist

Circle 194 on Reader Service Card



TopSpeed Modula-2

An integrated programming environment that produces efficient code

Barry Nance

There's been a growing curiosity in Modula-2. And TopSpeed Modula-2 for the IBM PC from Jensen & Partners International (JPI) is going to catch the attention of many programmers. Its integrated environment is slick, and its optimizing compiler is fast and efficient.

TopSpeed Modula-2 1.15 (\$99.95) works with an IBM PC or compatible with 512K bytes of RAM, two floppy disk drives, and DOS 2.1 or higher.

A Closer Look

The integrated development environment is similar to that of Borland's language products. It provides file-selection operations, an integral editor, a "smart" Make facility, a built-in linker, and a means to run tests of your programs from within the environment. It has a context-sensitive help facility that includes summary information on each of the options in the menu system and library routines.

TopSpeed's menu structure is file-driven and therefore completely configurable. It's easy to customize the default M2.MNU file to suit your personal tastes and development style. You can change the size, position, color, and even the contents of each of the menus. You can integrate other programmer tools and programs (such as the optional Tech-Kit and the TopSpeed full-screen debugger, VID) into the TopSpeed menus.

```

#1 C:\TOPSPEED\PROG4.MOD          Insert   TopSpeed M2   Col 1
MODULE prog4:
(* This program displays the permutations of a string
   in alphabetic order *)
IMPORT IO,Str:

TYPE StringType = ARRAY [0..9] OF CHAR;

PROCEDURE NextPerm(n:CARDINAL;
                  VAR s:StringType;
#3 C:\TOPSPEED\PROG5.MOD          Insert   ol 1
MODULE prog5:
(* this program lists the 9-digit numbers, containing every
   digit from 1 to 9 which are a product of three 3-digit
   numbers, which also contain every digit from 1 to 9 *)
IMPORT IO;
#4 C:\TOPSPEED\PROG8.MOD          Insert   Line 1   Col 1
MODULE prog8:
(* This program implements a simple interactive calculator *)
IMPORT IO,Str,Storage;

TYPE
TokenType = (number, add, sub, mul, div, LeftParen,
             RightParen, end);
Window  ←+tl-move  Shift ←+tl-resize  ←-recolor  ScrollLock+exit

```

You're not, however, chained to the integrated environment. If you are more comfortable with a command-line interface, you can invoke the compiler and the linker directly from the DOS prompt.

You can edit up to four files simultaneously in the multiwindow, built-in editor. You can resize, move, recolor, and zoom each window. You indicate which one of the windows is the main module and all the compile and make commands that apply to it. Switching from window to window is quick and easy.

The M2.MNU configuration file establishes the keystrokes for the editor commands, and you change it to set up the editor to your tastes. The default commands are WordStar-like, and pull-down menus are available for users who don't use the short-cut keystrokes.

Turning On the Make Utility

The Make utility is highly integrated with the Modula-2 language and Top-

Speed environment. If you give it a main-module name, it automatically figures out what needs to be recompiled to have an up-to-date executable file. If the compiler detects errors in a source file, you can drop immediately into the editor to fix them and then resume Make.

The .OBJ files emitted by the TopSpeed compiler are in standard Microsoft/Intel format, so you could use the Microsoft linker. But you probably won't want to. JPI's linker is faster, and it's smart enough to link in only the code that the program actually references.

You can specify various settings within the TopSpeed environment through a menu option. For example, you can set compiler directives to prepare the code for use with the debugger or set linker directives according to the sort of .MAP file you want to create. You can set directives to enter a command line for a program running inside the environment.

continued

TopSpeed Modula-2 comes with a set of main library routines that differ from the procedures suggested in version 3 of Nicklaus Wirth's Modula-2 definition. For purists, standard library modules are supplied as an alternative.

Checking the Code

The compiler can work quickly. Depending on the complexity of the source code, it will typically handle between 6000 and 10,000 lines per minute. The compiler always recompiles the visible portion of

any imported modules (the .DEF files), which slows down the compiler somewhat, but this means there are no restrictions on the ordering of the modules.

Of course, fast compilation speed and an integrated environment aren't everything. What really matters is the ability of the compiler to emit tight, fast, and correct machine code. Code generation is where TopSpeed Modula-2 shines.

I discovered this by looking at the actual machine code for common-language constructs emitted by the compiler. For

example, consider the Modula-2 code to initialize an array [1..1700] of characters (see listing 1a). The resulting machine code (see listing 1b) shows that the compiler is smart enough to recognize that the entire array is being initialized. The compiler sets up and then executes a single instruction (the REP STOSW) to perform initialization in-line, without calling a library routine and without initializing each byte separately.

A simple Modula-2 string assignment (see listing 2a) was also handled well by the compiler. The resulting machine code (see listing 2b) demonstrates that the TopSpeed compiler generated the string-assignment code in-line, and that it's smart enough to move 101 bytes as a 50-word move followed by a single-byte move.

I also tried another common program construct, the case statement (see listing 3a). Here, the TopSpeed compiler protects the program from crashing if the value of the control variable in the case statement is not within bounds (see listing 3b).

Special Features

TopSpeed Modula-2 comes with several special features. Among them is a time-slice process scheduler that you can use to create peer-to-peer, concurrently executing threads within a single program. It's easy to launch one or more threads, and you can control each thread's priority, interthread communications (i.e., accessing common variables), and process scheduling. In addition, JPI says that it is working on a version of TopSpeed Modula-2 that will take advantage of OS/2's multitasking features.

A special mechanism supports interrupt handlers, including compiler directives to cause procedures to save/restore registers and to end with an IRET instruction. But you can't place return values in registers, nor can you set the flag register within such a procedure. I had to resort to a separate assembler module to do what I wanted.

TopSpeed Modula-2 also comes with text-windowing facilities that are easy—even fun—to use. When you open a window, you can specify a window title, whether or not it has a frame, the characters (if any) that make up the frame, the row and column of the window, the attributes (colors) that you use, whether you want a visible cursor, and how you want the text in the window displayed. You can manage several windows at once and re-size, move, retitle, and hide them. With-

Listing 1: (a) A TopSpeed Modula-2 routine that initializes an array [1..1700] of characters is compiled **(b)** to perform initialization in-line, without calling a library routine and without initializing each byte separately.

(a)

```
FOR i := 1 TO SIZE(ch_array) DO
  ch_array[i] := '0';
END;
```

(b)

```
MOV    AX, 48           ; '0' is decimal 48
MOV    ES, CS:DataAreaSeg
MOV    CX, Offset ch_array ; set up addresses
MOV    DI, CX
MOV    AH, AL          ; turn '0' into a word of '00'
MOV    CX, 1700 / 2    ; count of words
REP    STOSW           ; store 850 words of '00'
                          ; with "repeat-store-string-word"
```

Listing 2: (a) When it compiles a simple string assignment, TopSpeed Modula-2 **(b)** moves 101 bytes as a 50-word move followed by a single-byte move.

(a)

```
s1 := "This is a string";
s2 := s1;
```

(b)

```
; s1 := "This is a string";

MOV    ES, CS:DataAreaSeg ; 1st assignment...set up addresses
MOV    DI, Offset s1      ; (ES:DI is destination)
MOV    SI, Offset str_constant
PUSH   CS                 ; constants are stored in code seg,
POP    DS                 ; so move is from CS:SI
MOV    CX, 8              ; word (not byte) count to move
REP    MOVSW              ; move 16 bytes (DS:SI to ES:DI)
MOVSB                               ; do 17th byte

; s2 := s1;

MOV    DS, CS:DataAreaSeg ; begin 2nd assignment
MOV    ES, CS:DataAreaSeg ; set up addresses
MOV    DI, Offset s2      ; destination
MOV    SI, Offset s1      ; source
MOV    CX, 50             ; string is 101 bytes, so
REP    MOVSW              ; do 1st 100 (as 50 words),
MOVSB                               ; then do last (101st) byte
```

in a window, you can place text in a variety of ways (including direct screen writes), and you can insert and delete text lines.

However, TopSpeed Modula-2 is relatively weak in graphics support. After initializing your program for a specific video adapter (there is no auto-detect), you can use TopSpeed's procedures for entering or exiting graphics mode; drawing dots; and drawing lines, circles, ellipses, and polygons. It supports CGA, EGA, VGA, Hercules, and AT&T graphics adapters. No special fonts come with the compiler (à la Borland's BGI), and there are no provisions for setting line widths or fill patterns.

For me, though, one of the best features of TopSpeed Modula-2 is that the library routines come in both object and source forms. Even if you never customize them, just having the code for reference purposes is invaluable.

A Case to Switch

If you are new to Modula-2, you will be happy to know that TopSpeed Modula-2 comes with a language tutorial and a

continued

Listing 3: (a) The TopSpeed Modula-2 compiler protects the case statement from crashing if (b) the value of the control variable is not within bounds.

(a)

```

CASE i OF
  0 : j := 0;
  1 : j := 1;
  2 : j := 2;
END;
    
```

(* if i is: set j to: *)
 (* 0 0 *)
 (* 1 1 *)
 (* 2 2 *)

Note: *i* was declared as a signed integer.

(b)

```

MOV DS, CS:DataAreaSeg
MOV AX, i ; get value of i
MOV BX, AX
SHL BX, 1 ; set up index for jump (i * 2)
CMP AX, 3 ; if i greater than or equal to 3,
JGE NSI ; just go to next stmt after the case
CMP AX, 0 ; do the same if i < 0
JL NSI
JMP CS:[BX+Tbl] ; go to Tbl+0, Tbl+2, or Tbl+4
Tbl: SUB AX, AX ; set AX to 0
JMP Store
MOV AX, 1 ; set AX to 1
JMP Store
MOV AX, 2 ; set AX to 2
Store: MOV j, AX ; store AX in j
NSI:
    
```

If You Can Find A Better Value In 386 Power — Buy It!

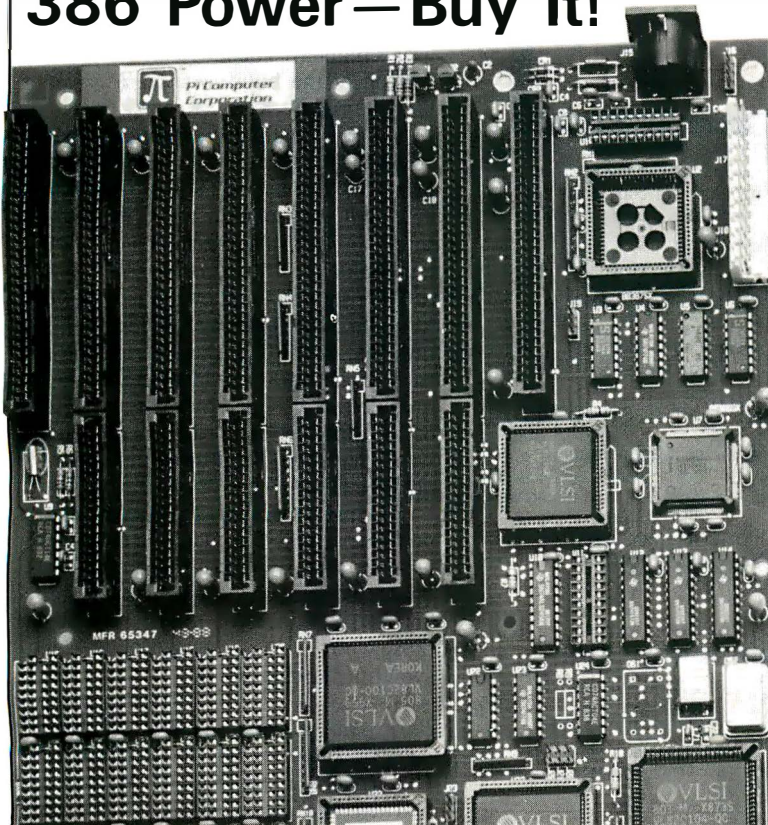

- ★ 20 MHz 386 Baby AT— \$949
- ★ Expands to 16MB
- ★ 287, 387, Shadow RAM Support
- ★ Award or Phoenix BIOS
- ★ 286s from \$285



TM
Pi Computer Corporation

Your Best Value in Motherboards*

P.O. Box 68
Earlsville, VA 22936
804-978-3917

- ★ THREE Year Warranty
- ★ 45 Day \$-back
- ★ Cases, P/S, RAM, Cards, Drives & Assembly Available



CALL
800-666-9248

*since 1983

QUALITY IN... QUALITY OUT

No matter how well acquainted you are with making important personal computing decisions—decisions that may involve hundreds of thousands of dollars—the value of those decisions is only as good as the value of your information. Without quality information—it's hard to make quality decisions.

BYTEweek, McGraw-Hill's new weekly newsletter for professionals in the personal computer industry, is devoted to giving you that quality information through its timely, compact one-stop news format.

Subscribe to BYTEweek for quality information. Remember, quality in...quality out.

Take advantage of the special one-year charter subscription rate of \$395 (\$495 outside the U.S. and Canada)—a savings of \$100. Your subscription includes 50 issues plus a free three-month subscription to BIX—a \$49 value.

Don't miss this opportunity! In the U.S., call BYTEweek's toll-free number: **1-800-258-5485**, in N.H. and outside the U.S., call: 1-603-924-9281.

BYTEweek offers a *money-back guarantee* if you're not completely satisfied.

BYTEWEEK

*News and Analysis for Professionals
in the Personal Computing Industry*
One Phoenix Mill Lane, Peterborough, NH 03458

TopSpeed Modula-2 version 1.15

Type

Modula-2 integrated development system

Company

Jensen & Partners International, Inc.
1101 San Antonio Rd., Suite 301
Mountain View, CA 94043
(415) 967-3200

Jensen & Partners U.K. Ltd.
63 Clerkenwell Rd.
London EC1M 5NP, U.K.
(01) 253-4333

Format

Three 360K-byte 5¼-inch floppy disks

Hardware Needed

IBM PC or compatible with at least 512K bytes of RAM, two floppy disk drives
(a hard disk drive is recommended)

Software Needed

DOS 2.1 or higher

Documentation

User's manual; language tutorial; quick reference card

Price

\$99.95

Inquiry 883.

user's manual. The language tutorial is a version of the book *Modula-2: A Complete Guide* by K. N. King (Lexington, MA: D.C. Heath, 1988), condensed and adapted specifically to the TopSpeed Modula-2 system. You will find it thorough and helpful, and it will likely save you from having to buy "helper" textbooks.

The user's manual explains TopSpeed Modula-2 with examples and formal definitions, including the definitions for each of the library modules. The library modules are grouped by category instead of in alphabetical order. I personally would have preferred them in simple alphabetical order.

TopSpeed Modula-2 is tempting. It generates tight, fast machine code—better code than some leading C compilers. And it comes with a wealth of features and tools. I think it might even tempt those who have never used Modula-2 into switching languages. ■

Barry Nance works in the R&D department at Programming Resources Co. in Hartford, Connecticut. He can be reached on BIX as "barryn."

UTAH

COBOL™

NEW
VERSION 5.0

\$69.95

For IBM® PC's, XT's, AT's and other DOS machines. Needs only 1 disk drive and 128K memory. This is the one you've heard so much about - with fast compile times, small object code modules, not copy protected, no royalties, and clear error messages. Version 5.0 is based upon ANSI-74 standards with new dynamite features including:

- Nested IF's and nested conditions.
- Indexed files (ISAM) with up to 24 keys (includes START verb). This advanced feature requires the software package Btrieve® which is optionally available.
- ACCEPT (line, column) numerics with decimal point alignment, numeric CAPE KEY, DAY, DATE, TIME, DAY-OF-WEEK.



checking, AUTO-SKIP, SECURITY, LENGTH-CHECK, EMPTY-CHECK, ATTRIBUTE (color), FROM ES-CAPE KEY, DAY, DATE, TIME, DAY-OF-WEEK.

• Fast memory mapped DISPLAY's (line, column) ERASE, BEEP, ATTRIBUTE (color). Can display entire screen with one DISPLAY statement.

• Windowing, pop-ups, color and overlays. This advanced feature requires the software package Saywhat?!™ which is optionally available.

• An easy to use, COBOL source code EDITOR with auto line numbering, A-margin, B-margin tabing with full screen cursor control.

Also available: Utah SuperSort®, a fast sort program callable from Utah COBOL; Utah FORTRAN; Utah BASIC; Utah PASCAL; Utah PILOT. Used by 50,000 professionals, students and teachers in 40 countries. 30-day money back guarantee. Discover the ease and simplicity of COBOL, today!



Since 1977

Ellis Computing, Inc.
5655 Riggins Court, Suite 10
Reno, Nevada 89502

Phone order rushed
by UPS 2nd Day Air:
(702) 827-3030

IBM is a registered trademark of International Business Machines, Inc. Btrieve is a registered trademark of Novell, Inc. Saywhat?! is a trademark of The Research Group. SuperSort is a registered trademark of Micropro International Corporation. Utah COBOL is a trademark of Ellis Computing, Inc. © 1987 Ellis Computing, Inc.

See DOS run.

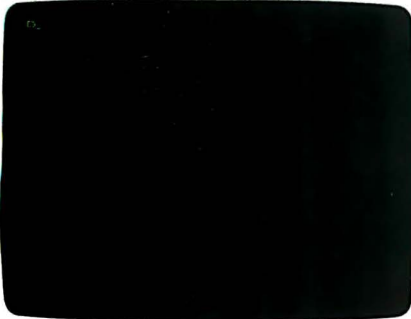

Look at DOS. It looks back at you. It makes you do all the work. You need the Norton Commander.



See this user-defined menu. It runs your favorite programs and routines at a keystroke.

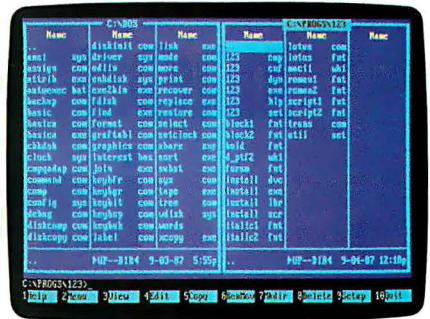

View two directories—from one or two disks—at once. And move your files around quickly.



Pull down a menu for quick, easy access to the full power and features of the program.

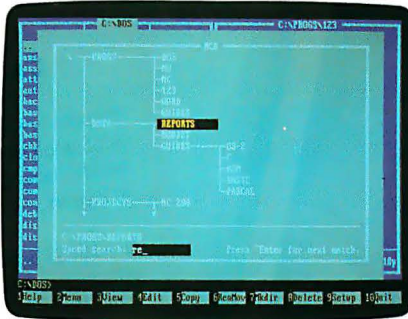

Want a tree view? Just pop up a window. You can scroll, mouse or Speed Search for directories.

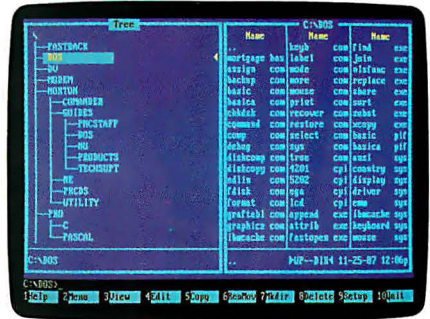

To see your files, pick a directory on the left and see the contents on the right.



Remember your last 15 commands? Our Command History does. Take your pick and run them again.



View your dBASE® II or III data without having to run dBASE. It's as close as a keystroke.



Another keystroke shows Lotus® 1-2-3® or Symphony® files—without running 1-2-3 or Symphony.

See DOS run like you've never seen it before. Like you won't see it run with any other DOS enhancement shell. See version 2.0 of the Norton Commander™—a dramatically advanced version of the program *Infoworld* called "tops in its class... a new level of convenience for MS/DOS users." The new Norton Commander combines the functions of a hard disk manager with all the features you need to support and enhance the DOS command line. Yet it's flexible enough to get out of your way when you don't need to see it. Novice or expert, you'll want to see your dealer right away. And see how fast DOS can run.

Peter Norton
COMPUTING

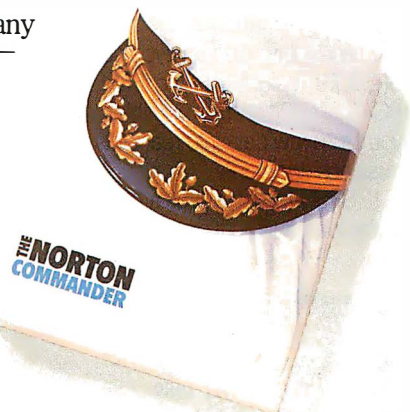

Circle 207 on Reader Service Card (DEALERS: 208)

Designed for the IBM® PS/2® and PC families, and 100% compatibles. Available at most software dealers, or direct from Peter Norton Computing, Inc., 2210 Wilshire Blvd., #186, Santa Monica, CA 90403. 213-319-2000. Visa and MasterCard welcome. ©1988 Peter Norton Computing.

We'll take your stats and make you the most valuable player in your league.

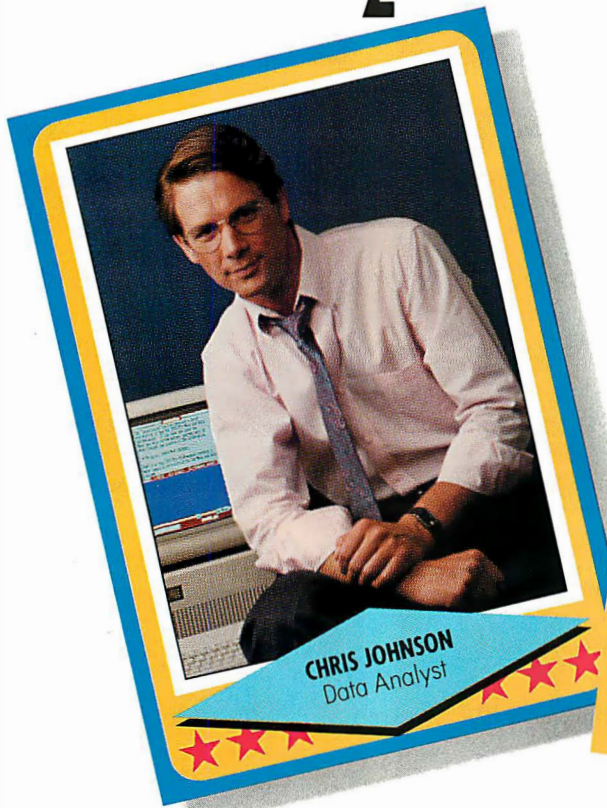

★
CHRIS JOHNSON Data Analyst

CAREER HIGHLIGHTS

1983
Proposed remap of sales territories based on SPSS analysis of economic and consumer trends. Increased new-customer revenues 38% in 2 years.

1985
Used SPSS data entry/tabulation system to administer employee benefits more efficiently. Eliminated outside costs of more than \$75,000.

1986
Identified current customers likely to need added services, increasing average billings by more than 20%.

1988
Rewarded with special corporate recognition and bonus.

★ Another Story in the SPSS SUCCESS SERIES ★

Data analysis software from SPSS® gives your PC a winning advantage.

It doesn't matter which field you play hardball in. The right combination of equipment and ability can make you a hero.

You get that ability with SPSS/PC+™, the best-selling data analysis software from SPSS. It's designed for the IBM PC/XT,™ PC/AT,™ PS/2™ and compatibles. And with it, you'll turn raw data into real facts, for sound business decisions.

SPSS/PC+ features a base package of numerous statistical procedures. Plus some

powerful options for data entry, advanced statistics, forecasting, graphics, mapping and much more. So you can scrutinize and manipulate your data in countless ways.

SPSS/PC+ also provides a seamless interface with other popular PC software such as dBase™ and 1-2-3,™ to give you complete command of your data. For market research, sales analysis, quality control and much more.

Yet, SPSS/PC+ is designed for ease-of-use. It features a menuing and help system, as well as an on-line statistical glossary that helps you interpret results as you go.

And you'll always have training, support,

and ongoing upgrades from SPSS. The team that's supplied statistical software to over 1 million users since 1968.

For more details on how SPSS/PC+ can help you get the most out of your micro, give us a call at

1-312-329-3315.

We'll show you how to really stand out in your field.

SPSS inc.

Best in the final analysis.

444 North Michigan Avenue • Chicago, Illinois 60611

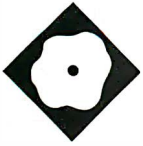

A Different Kind of CASE Tool

Logic Gem might change the way you look at programming

Andrew Schulman

Associating the word *logic* with programming suggests AI. But Sterling Castle's Logic Gem isn't an AI program. It is a tool that you use to explore program logic by means of decision tables.

Listing 1 shows a snippet of C code. In Logic Gem, items like `(argc > 2)` and the return value from `DosOpen()` are *conditions*, and items like the command `exit()` or setting the variable `cflag` to 1 are *actions*. A decision table is a matrix associating a series of conditions with a set of actions. The basic decision table consists of four sections: condition stub, condition entries, action stub, and action entries.

A decision table equivalent to the code example might look like table 1. The number 2 on lines C1 and C2 indicates that these are simple Boolean operators that can be either yes (y) or no (n). A set of two such two-way conditions presents four possible combinations of values or rules: both true (y/y), the first true and the second false (y/n), the second true and the first false (n/y), and both false (n/n). These combinations appear in the upper right corner of the decision table. In this example, y/y is a more concise way of saying:

```
if ((argc > 2) && (DosOpen
    (argv[2], &cfile, ...)))
```

Each combination of conditions carries with it one or more actions. If both

| TABLE: parser.tab | | LABEL 1 | | | | | | | | | | | | | | |
|--|--------------------|-----------------|---|---|---|---|---|---|---|---|---|----|----|----|----|----|
| RULE | | COMP: 128 : 128 | | | | | | | | | | | | | | |
| | | n | 1 | 2 | 3 | 4 | 5 | 6 | 7 | 8 | 9 | 10 | 11 | 12 | 13 | 14 |
| C1 | length == 1 | 2 | y | n | n | n | n | n | n | n | | | | | | |
| C2 | c == '\n' | 2 | - | y | n | n | n | n | n | n | | | | | | |
| C3 | c == BACKSPACE | 2 | - | - | y | y | n | n | n | n | | | | | | |
| C4 | i == 0 | 2 | - | - | y | n | - | - | - | - | | | | | | |
| C5 | typ == NUMERIC | 2 | - | - | - | - | - | y | y | n | | | | | | |
| C6 | isdigit(c) | 2 | - | - | - | - | - | y | n | n | | | | | | |
| C7 | i == length | 2 | - | - | - | - | y | n | n | n | | | | | | |
| A1 | beep() | | | | 1 | | 1 | | 1 | | | | | | | |
| A2 | addch(c);refresh() | | 1 | | | | | | 1 | | 1 | | | | | |
| A3 | str[i] = c | | 2 | | | | | | 2 | | 2 | | | | | |
| A4 | str[i+1] = '\0' | | 3 | | | | | | 3 | | 3 | | | | | |
| A5 | backup(1) | | | | 1 | | | | | | | | | | | |
| A6 | i++ | | 4 | | | | | | 4 | | 4 | | | | | |
| A7 | break | | | | 1 | | | | | | | | | | | |
| Type (S)hut off NMI, (R)eboot, other keys to continue | | | | | | | | | | | | | | | | |
| Save Load Print Table file Compiler file Print file Quit | | | | | | | | | | | | | | | | |
| Load New Table (File) | | | | | | | | | | | | | | | | |

conditions C1 and C2 are true, then actions A3 and A4 are invoked: Call `fprintf()` and then `exit()`. The numbers 1 and 2 in the lower right corner indicate the order in which to carry out A3 and A4. On the other hand, if neither C1 nor C2 is true (n/n), then the decision table shows that A2 should be triggered.

The Logic Editor

A decision table, then, is a logical spreadsheet, and the Logic Editor portion of Logic Gem helps construct such tables. After opening a fresh table, you type in your conditions and actions on the left side of the screen and then use the Logic Gem Missing command to fill in the missing rules. In the case of a series of simple two-way conditions, Logic Gem supplies a complete set of y/n combinations. You specify which actions are triggered by each y/n combination. In my example, the combination (C1 && C2) triggers A3 and A4, and the combination

(C1 && !C2) triggers A1.

Logic Gem evaluates the matrix and can detect inconsistencies. For example, in table 1, the combinations n/y and n/n produce the same result. The program's Reduce command eliminates this redundancy, as shown in table 2. If C1 fails, there is no point in testing C2; thus, table 2 is more concise and more accurate than table 1. Logic Gem happened to remove this error while reducing the table, but applying strict Venn diagram-type logic to the world of programming does present a problem: Side effects are often disguised as logical tests. For example, the command `DosOpen` is a side effect that is in no way reflected in the table. It just shows a return value "yes," meaning that `DosOpen` failed.

Logic Gem replaces the n/y/A2 and n/n/A2 decisions with a single n/-/A2 decision. The hyphen indicates "don't care" and plays a crucial role in decision

continued

tables. When a Logic Gem condition is marked with a 2 to indicate Boolean two-way logic, the condition can take on three values: y, n, or -. Likewise, a Logic Gem condition marked with a 3 can take four

values: a, b, c, or -.

Logic Gem can also detect and eliminate ambiguities. Adding a rule such as n/n/A1 to table 2, which contains the rule n/-/A2, would be ambiguous. Logic

Gem "disambiguates" a table by eliminating rules. In this case, Logic Gem would eliminate n/n/A1, because rules with a hyphen contain more information than rules without it.

Sometimes Logic Gem's Disambiguate command eliminates rules that are indeed ambiguous but that you still may want to keep. And its Reduce command ruthlessly eliminates rules for which you have not yet specified an action. For this reason, the Undo command is important, even though it backs up only one level; it is primitive, consisting of .BAK files on disk. A Readme file on disk uses a Logic Gem decision table to document the situations under which the program creates .BAK files.

All Logic Gem commands are available through a pop-up menu that you access with the forward slash (/) key (confusingly called the right backslash key in the Logic Gem manual). All major logic-editing functions appear in the Table menu, but not in the best order. For example, important commands like Reduce and Missing appear in a submenu called More. Sterling Castle promises a more logical menu structure in future releases.

Listing 1: Sample C code used to illustrate Logic Gem functions.

```
if (argc > 2)
    if (DosOpen(argv[2], &cfile, &act, 0L, 0, 0x12, 0x0022, 0L))
        { fprintf(stderr, "\nErr: %s\n", argv[2]);
          exit(1); }
    else
        cflag = 1;
else
    cflag = 0;
```

Table 1: The Logic Gem decision table from the C code in listing 1.

| | | | | | | |
|----|-----------------------------------|---|---|---|---|---|
| C1 | argc > 2 | 2 | y | y | n | n |
| C2 | DosOpen(argv[2],&cfile,...) | 2 | y | n | y | n |
| A1 | cflag = 1 | | | 1 | | |
| A2 | cflag = 0 | | | | 1 | 1 |
| A3 | fprintf(stderr,"\nErr: %s\n",...) | 1 | | | | |
| A4 | exit(1) | 2 | | | | |

Table 2: The decision table after executing the Logic Gem Reduce command.

| | | | | | |
|----|-----------------------------------|---|---|---|---|
| C1 | argc > 2 | 2 | y | y | n |
| C2 | DosOpen(argv[2],&cfile,...) | 2 | y | n | - |
| A1 | cflag = 1 | | | 1 | |
| A2 | cflag = 0 | | | | 1 |
| A3 | fprintf(stderr,"\nErr: %s\n",...) | 1 | | | |
| A4 | exit(1) | 2 | | | |

Listing 2: Sample C code that Logic Gem converts back to C from a decision table.

```
dosopen.tab()
{
    if (argc > 2) {
        if (DosOpen(argv[2],&cfile,&act,0L,0,0x12,0x0022,0L)) {
            /* rule 1 */
            fprintf(stderr, "\nErr: %s\n", argv[2]);
            exit(1);
        }
        else {
            /* rule 2 */
            cflag = 1;
        }
    }
    else {
        /* rule 3 */
        cflag = 0;
    }
}
```

New Programming Perspectives

Why transform IF... THEN logic into a decision table? Logic Gem can verify that all possible states have corresponding actions so that program logic is complete. This increases your confidence in the program and, in addition, verifies its correctness.

Seeing program logic in the form of y/n/- patterns provides new and interesting perspectives. Many of these are stock patterns (e.g., the "upside-down staircase" in the Logic Gem manual), and a future version of Logic Gem might construct these archetypal logic diagrams automatically. In any event, the ability to picture a large block of code as a tiny table of rules, which often conforms to some standard pattern, is one of the great benefits of Logic Gem.

It is also a major drawback. On a standard PC screen, you can usually see an entire table without scrolling. This is a restriction with Logic Gem because you can specify only nine conditions. While it's true that 2⁹ is 512, the use of the don't-care symbol reduces the number of combinations to something manageable, if not limiting.

The reason for the nine-condition limit is that a larger number would require two digits, chewing up valuable screen real estate. You could argue that this is a reasonable trade-off; it lets you view entire

tables at once, and you will probably never need to exceed the program's limit, anyway.

Associating patterns with program logic may do for many people what flowcharts never could. The ability to associate a set of condition-action rules with a pattern puts Logic Gem halfway between a simple textual description and a graphical flowchart.

The Code Generator

Logic Gem is also a code generator. From a decision table, Logic Gem can generate code in C, Pascal, line-numbered or structured BASIC, FORTRAN, or dBASE III Plus. Surprisingly, neither LISP nor Prolog is included. It would have been better if, rather than hard-wiring specific languages into Logic Gem, the program author had provided a meta-language or template format that would describe the form of the code generator's output.

Logic Gem does a reasonable job of transforming a decision table into compilable code, converting the decision table created from the sample C code from BYTE back to C, as shown in listing

2. The result is straight IF...ELSE code. Logic Gem cannot yet generate case/switch statements, jump/dispatch tables, or state-machine tables. The company says that a future version of Logic Gem will generate case/switch statements.

Note that the Logic Gem-generated C function is called `dosopen.tab()`. The program got this illegal function name from the decision table filename. While the code refers to variables like `cflag` and `act`, these are neither declared as local variables nor passed on as arguments. Because the condition and action stubs are just passed through to the code generator, Logic Gem knows nothing about your code. The result is that you will have to add your own variable declarations. This is no big deal and is unavoidable, but it isn't true that Logic Gem-generated code compiles the first time, as the manual implies.

Logic Gem-generated code tends to fall off the right side of the page, because it generates IF...ELSE code and defaults to eight-character-wide tab stops. You can change Logic Gem's defaults by modifying the file `LGCONFIG`.

continued

Logic Gem 1.0 (Programmer's Edition)

Type

Decision-table editor, code generator, and logic interpreter

Company

Sterling Castle
702 Washington St., Suite 174
Marina del Rey, CA 90292
(213) 306-3020

Format

One 5¼-inch floppy disk and one 3½-inch floppy disk

Hardware Needed

IBM PC, PS/2, or compatible with 640K bytes of RAM, DOS 2.0 or higher, and a monochrome monitor

Documentation

User's guide and reference guide

Price

\$198

Inquiry 881.

A MESSAGE TO OUR SUBSCRIBERS

FROM TIME TO TIME WE MAKE THE BYTE subscriber list available to other companies who wish to send our subscribers material about their products. We take great care to screen these companies, choosing only those who are reputable, and whose products, services, or information we feel would be of interest to you. Direct mail is an efficient medium for presenting the latest personal computer goods and services to our subscribers.

Many BYTE subscribers appreciate this controlled use of our mailing list, and look forward to finding information of interest to them in the mail. Used are our subscribers' names and addresses only (no other information we may have is ever given).

While we believe the distribution of this information is of benefit to our subscribers, we firmly respect the wishes of any subscriber who does not want to receive such promotional literature. Should you wish to restrict the use of your name, simply send your request to the following address.

BYTE MAGAZINE
ATTN: SUBSCRIBER SERVICE
P.O. Box 7643
TEANECK, NJ 07666-9866



RS-422 CONVERTER TO/FROM RS-232

- Up to 100 kilobaud at 4000 feet
- Up to 3 miles at 1200 baud
- Supports eight signals
- Doubles as a high speed short haul modem
- All handshake signals and clock
- Write or call to order or for more information

TELEBYTE

A PUBLIC COMPANY

Remark Division • Telebyte Technology, Inc. • 270 E. Pulaski Rd.
Greenlawn, NY 11740 • (516) 423-3232 800-835-3298

The Logic Gem code generator can guarantee a minimum number of tests. It recursively decomposes a decision table into subtables, printing condition stubs as it discards rows, and printing actions as isolated rules. Sorting rules govern the walk down the tree of subtables. A submenu lets you control which sorting rule the code generator uses.

The more interesting sorting rules involve frequency and cost. At the bottom of each y/n/- combination, you can indi-

cate the expected frequency with which this decision occurs and estimate the cost associated with it. Within the context of minimizing the number of comparisons used in isolating a rule, Logic Gem can sort frequent rules first or costly rules last, or it can use a heuristic collation method.

The Logic Interpreter

Logic Gem can serve as a logic interpreter as well. For instance, running the

DosOpen() decision table under the interpreter might yield the following scenario:

```
argc > 2 :
y> Yes
n> No
y
```

```
DosOpen(argv[2], &cfile, ...) :
y> Yes
n> No
n
```

```
RULE 2
cflag = 1
```

In addition to executing your decision table in expert-system form, the Logic Interpreter is also a language. Actions or conditions can call subtables; actions can return values to calling tables or set the value for a condition; and actions or conditions can execute DOS commands or display files. When a condition calls a subtable or executes a DOS command, the value of the condition is picked up from the subtable or from a file that Logic Gem uses to communicate with other programs.

All this is done with a tiny instruction set: CC (condition call), CD (condition display), CE (condition execute), AC (action call), AD (action display), AE (action execute), AI (action include), AL (action loop), AP (action proceed), AR (action return), AS (action set). For instance, the action AS 2 n would loop back to the top of the decision table, setting condition 2 to no. You will find this very useful for simulating state machines.

Unfortunately, these commands have no meaning in the other components of Logic Gem. In particular, interpreter commands that chain to another table or loop back to the beginning of the current table are ignored by other parts of the program. So, outside the interpreter, Logic Gem is not suited for handling logic that involves WHILE rather than IF conditions.

What is great about Logic Gem is the way it reveals unsuspected patterns in your code. The program could use a smoother user interface and a more logical menu structure. But for programmers who already use decision tables or would like to use them, Logic Gem should prove to be a valuable tool. ■

Andrew Schulman is a software engineer living in Cambridge, Massachusetts. He can be reached on BIX c/o "editors."

TRY THIS ON A STANDARD DESKTOP PUBLISHING SYSTEM

$$\int_{-\infty}^n \frac{Xy \cdot Z dt}{X - tY} = \sum_{i=1}^n \left(\frac{(x^4 - i)^3}{\sqrt{Z^3 + y^{10}}} \right) \left(\frac{1}{Z - X^5 Y} \right)$$

For professional looking mathematical formulation, tables and scientific notation—no matter how complex—PC T_EX is unequaled. That's why many university engineering departments and scientific societies now require papers for publication be submitted in T_EX. In the world of desktop publishing systems, INFOWORLD rated PC T_EX #1, saying: "...No non-T_EX-based program has such a comprehensive built-in grasp of typological aesthetics..."

And from PC MAGAZINE: "...You can achieve incredible precision in formatting text, especially mathematical expressions."

WHEN YOU ADD PC T_EX, COUNT ON MORE THAN PRETTY NUMBERS.

TYPESET & MANUALS, BOOKS & FORMULAS & TABLES

in the same format or different ones

BIG OF SMALL LETTERS OR NARROW LETTERS OF BOLD

IT'S NICE TO KNOW PC T_EX WON'T LIMIT YOUR IMAGINATION.

Finished with the formula? Then try ▲ this formatting exercise on a standard desktop system. All positioning, sizing and typesetting are done with PC T_EX—no more cut'n'paste.

INFOWORLD again: "...Enormously flexible and offers complete control over the output of your printer."

And with Bitstream's 30+ font families, any type of type you like is easy as ▶ **A, b, c**

PC T_EX = the professional camera-ready, publisher-ready manuscripts you want.

PC T_EX SUBTRACTS TIME FROM AUTHOR TO PRINTED PIECE, MULTIPLIES AUTHOR CONTROL.

For a free PC T_EX demo diskette, the new PC T_EX 88 product catalog and information on a PC T_EX configuration for your system, give us a call at

415-388-8853

TRY IT WITH PERSONAL T_EX INC

12 Madrona Ave. Mill Valley CA 94941

PC T_EX is a registered TM of Personal T_EX, Inc. T_EX is an American Mathematical Society TM. Manufacturer's product names are their TMs. Inquire about PTI distributorships. Site licenses available to qualified organizations. This ad was typeset using PC T_EX and Bitstream fonts.



A Window on Word Processing

Ami brings affordable word processing and desktop publishing to Microsoft Windows

Lamont Wood

In the PC world, you generally have a choice of either word processing or desktop publishing. With the new

Ami word processor from Samna Corp., you can have a little of both. Depending on your needs, it may be enough—and it's certainly more than you might expect for \$199.

Ami is a Microsoft Windows-based word processor that combines on-screen graphics, some WYSIWYG, font control, layout control, and other desktop publishing features with traditional word processing features, such as spell checking, cut-and-paste, and search-and-replace functions.

However, it is not as thorough as some high-powered and usually expensive word processing or desktop publishing packages—although this may not matter to most users. Also, you cannot use Ami on an IBM PC or XT. In fact, it is shipped on high-density floppy disks, precluding its use on a PC (although you can get 360K-byte disks by arrangement). Ami requires an IBM PC AT, PS/2, or compatible with Hercules, EGA, or VGA graphics, 640K bytes of memory, and about 2.4 megabytes of available hard disk space.

Ami joins a nearly empty field of Windows-based word processors. Previously, there was Windows Write, a rudimentary notepad facility bundled with Microsoft Windows, and NBI Legend, a

full-blown word processing, desktop publishing package that costs \$698. Actually, you don't have to buy Windows to run Ami, since it comes with a Windows run-time package. Using Windows, however, lets you transfer text and graphics between Ami and other Windows applications using the Windows Clipboard function.

The Two Modes

When you load Ami, you get a typical Windows screen, with a menu list across the top and icons along the left edge representing various functions. Along the right side of the screen is a scroll bar, although you can also scroll through the text with the cursor-control keys.

The screen itself can be in either layout or draft mode. In draft mode, the menu, icons, and scroll bars remain, but the work area contains only monospaced text, like any word processor you'd have seen five years ago. You can apply attri-

butes for centering, boldfacing, and so forth in the draft mode, but, in most cases, there is no change in how the text is displayed—it remains left-justified, monospaced text. Even the margins aren't displayed.

You can then toggle into the layout mode, and suddenly you're in another world. The text now shows all the assigned attributes. If you've used a proportional font, the text will look about the same as it does when printed. Right margins are adjusted automatically for different type sizes. What you see is, roughly, what you get—including the margins, which are shaded.

You can compose text in either layout or draft mode and perform all the word processing functions. These include use of a 130,000-word spelling dictionary and control over margins, headers, footers, tab settings, and so on. You can align and justify text in various ways, and you

continued

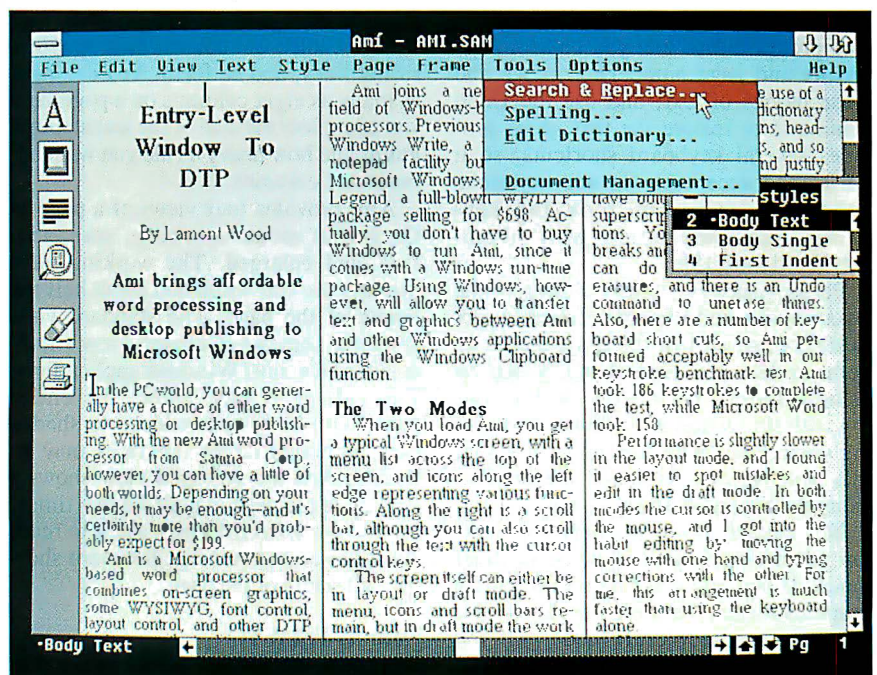

Ami

Type

Word processor with desktop publishing features

Company

Samna Corp.
5600 Glenridge Dr.
Atlanta, GA 30342
(404) 851-0007

Format

Four 5¼-inch high-density floppy disks

Hardware Needed

IBM PC AT, PS/2, or compatible with 640K bytes of RAM; one floppy disk drive; hard disk drive with 2.4 megabytes of free space; Hercules, EGA, or VGA graphics

Software Needed

DOS 3.0 or higher

Documentation

User's guide, style-sheet guide, Microsoft Windows guide

Price

\$199

Inquiry 882.

can choose from boldface, italic, underline, superscript, and subscript options. The program also lets you control page breaks and page numbering, move and erase blocks of text, and use the Undo command to restore the text. Ami provides several keyboard shortcuts, so it performed acceptably in our keystroke benchmark test. Ami took 186 keystrokes to complete the test, while Microsoft Word took 158.

Performance is slightly slower in the layout mode, and I found it easier to spot mistakes and edit in the draft mode. In both modes, you control the cursor by using a mouse. I got into the habit of editing with the mouse in one hand and typing corrections with the other. For me, this arrangement is much faster than using the keyboard alone.

You cannot, however, perform desktop publishing functions while in draft mode. If you add a frame and import a graphics image, there is no evidence of it when you toggle to draft mode. All you can view in the draft mode is the raw text.

Ami's Desktop Publishing

Ami's approach to desktop publishing can be likened to a stripped-down, mass-market version of the approach used by Xerox's Ventura Publisher, a leading desktop publishing package. Ventura Publisher's approach centers around style sheets, paragraph tagging, and frames.

Style sheets are a combination of margin, tab, alignment, and other settings, along with a list of named style tags. As in Ventura Publisher, each of Ami's style sheets resides in a separate file and can be attached to one or more documents, with those documents having full use of the features it defines. Unlike Ventura Publisher, Ami's style sheets can be restricted to one document so that changes to that sheet won't affect other documents that happen to use it.

An individual style tag would concern itself with an individual text element on a page. Consider, for instance, the address field on a business memo. It would start out with a left-justified "TO:" followed by a tab setting. You might also want to use italics and a left margin to place it under your letterhead logo. You could define elements through Ami's Style menu and then give it a name. You can apply a style by simply clicking on it with the mouse.

You can create and save style tags together as a new style sheet. Ami comes with 25 canned style sheets, whose tags you can easily modify. Ami also provides excellent facilities for creating style tags, with windows showing what a selected font and paragraph look like with a choice of indents, line spacing, ruling lines, and so forth. You can have as many as eight columns on a page, and you can select the size of the intercolumn gutter and how heavy a rule you want between the columns.

Ami provides four views of a page in the layout mode: working, standard, full, and enlarged. The working view displays the full width and about half the length of the page. The standard view shows a somewhat closer view that's standard for most Windows applications. The full-page view shows the entire page, with body text reduced to shaded bars, although larger typefaces may be legible. And the enlarged view shows a portion of the page magnified two times. I found the standard view easiest to read, but it has a shortcoming: It cannot show the full width of the page.

Near WYSIWYG

What you see in these layout views may or may not be what you get. That is be-

cause Ami can use downloadable laser-printer soft fonts but does not automatically generate matching screen fonts. The only printer font it comes with is Courier, a monospaced imitation of typewriter output. If you need other fonts, you will have to acquire them elsewhere.

For instance, I was able to load some Hewlett-Packard LaserJet soft fonts previously created for a Ventura Publisher system. Ami's Fonts facility let me direct Ami to the subdirectory containing the Ventura Publisher fonts. The program immediately listed by name and size the fonts that it recognized there. I highlighted the ones I wanted, and Ami then copied them to a special subdirectory that it created.

From then on, I could use those fonts in Ami whenever I wanted. However, the fonts that Ami was showing on the screen were selected from its list of canned screen fonts. It comes with eight screen fonts, including Courier, Helvetica, Times Roman, and Script. If you type in layout mode, the lines will wrap and the letters will space themselves. Then, as you leave a paragraph, or about 10 seconds after you stop typing, the program will suddenly reformat the lines and spaces.

The reformatting takes place because Ami knows the letter spacings of the selected printer font even if it is not using them on the screen as you type. The spacing is read from the font files when you select them. As you type, Ami uses the spacings of the screen font. After you stop, it applies the printer font spacings to what you've typed. The result may not look perfectly aesthetic on the screen, but the hard copy you print will look fine. And the line breaks appear in the same places on the screen as they do on the printout.

Also, because Ami has only a few canned screen fonts, the typeface it shows on the screen may not resemble the printer fonts. For example, I loaded a novelty printer typeface called Broadway. Ami did not have a matching screen font, so it simply displayed Times Roman. However, Ami did use the correct spacing for Broadway, so I could judge what the printout would look like.

Frames and Graphics

As with Ventura Publisher, you can add frames to a page. A frame is an enclosure whose contents are separate from the rest of the page. It is used for things such as positioning sidebars in a newsletter, importing graphics, and placing special elements, like logos.

Ask The Doctor Your Most Important Questions About PC Data Security.

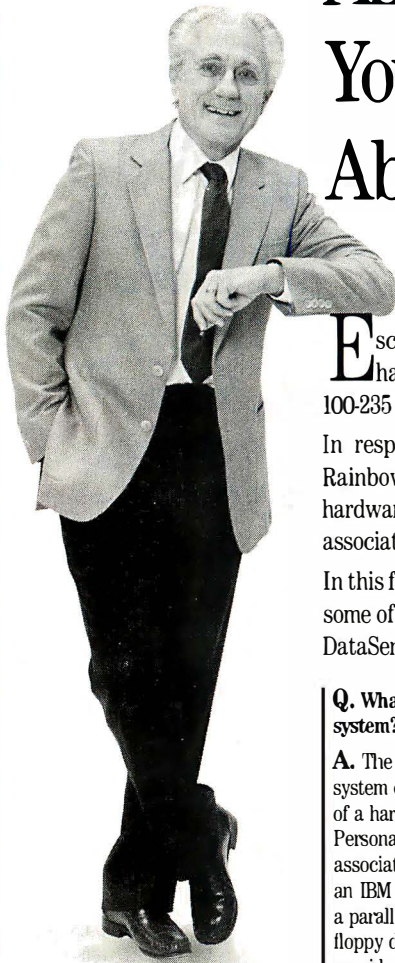

Escalating instances of PC data theft and misuse affecting both government and industry have shown the need for an effective yet easy-to-use data security product. U.S. Public law 100-235 now mandates that government agencies protect sensitive data files.

In response, Dr. Alan K. Jennings, Ph.D., inventor and co-founder of Rainbow Technologies, has designed the DataSentry™, an external hardware key that provides data file security without the problems associated with internal hardware and software-based protection.

In this first of a series of informational bulletins, Dr. Jennings answers some of the more frequently asked questions on PC data security and the DataSentry system from Rainbow Technologies.

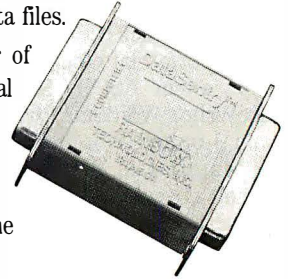

Q. What is the DataSentry system?

A. The DataSentry protection system consists of a combination of a hardware encryption device – Personal Access Key – and associated software that runs on an IBM or compatible PC having a parallel printer port and a floppy disk drive. The DataSentry provides three types of security: mandatory use of the access key to open a file, encryption and password protection.

Q. What is inside the Personal Access Key?

A. Inside each pocket-sized Personal Access Key is a proprietary custom-designed integrated circuit, often referred to as an Application Specific Integrated Circuit (ASIC). This ASIC was designed by engineers at Rainbow Technologies specifically for the DataSentry system. The full capabilities of the ASIC are known only to Rainbow. In operation, the proprietary ASIC implements a special function called an algorithm, chosen from many thousands of possible algorithms when the key is being manufactured at the Rainbow factory.

Q. What is the disadvantage of password-only software protection?

A. The main disadvantage of password-only protection is that users find it difficult to remember a password unless it is something quite familiar to them – like their spouse's name, their dog or the street they live on. It was recently estimated that about 75% of ARPANET passwords could be discovered by trying these three choices. Choosing a less familiar name requires that it be written down. This, of course, is a security risk. As a result, password-only protection is fairly easy to defeat.

Q. What is the advantage of external hardware keys over internal security boards?

A. Some protection systems depend on circuit boards being installed inside the PC. In addition to objection to the expense of installation and training, many users are reluctant to open their PCs. IBM PS/2s and laptop PCs do not accept the standard add-in boards. As a result, nearly all PC users have a strong preference to the addition of low-cost external hardware to achieve the desired protection.

Q. Is the DES (Data Encryption Standard) government-specified algorithm available with the DataSentry system?

A. Yes. The DES algorithm as defined by U.S. government standard FIPS 46 is implemented in the DataSentry system.

Q. Can the DataSentry system be used on local area networks?

A. Yes. It can be used on LANS as long as the automatically protected files are stored on a local computer. It does not matter if the application is stored on the local PC, on a shared file server or on any other PC.

Q. Can a DataSentry system be used to secure mainframe data files?

A. Yes. The mainframe could send files to the PC for encrypting or decrypting.

Q. What are some of the new special features of the DataSentry system?

A. Audit trail, log-on identifiers, and automatic encryption/decryption of entire directories.

To consult Dr. Jennings and the DataSentry sales staff about your personal data security questions, call Rainbow Technologies today.

Data Sentry™

- Completely user-installable
- Pocket-sized external device
- Menu-driven, user-friendly interface
- Single- or multi-user security system
- Audit trail, log-on identifiers and automatic encryption/decryption of entire directories
- Secures data transmitted by modems
- Prevents recovery of data by utility programs

Dealer Inquiries Welcome.



RAINBOW TECHNOLOGIES

18011-A Mitchell South, Irvine, CA 92714 • (714) 261-0228 • TELEX: 386078 • FAX: (714) 261-0260
Rainbow Technologies, Ltd., Shirley Lodge, 470 London Rd., Slough, Berkshire, SL3 8QY, U.K., Tel: 0753-41512, Fax: 0753-43610

© 1989 Rainbow Technologies. All product names are trademarks of their respective manufacturers.

Unix

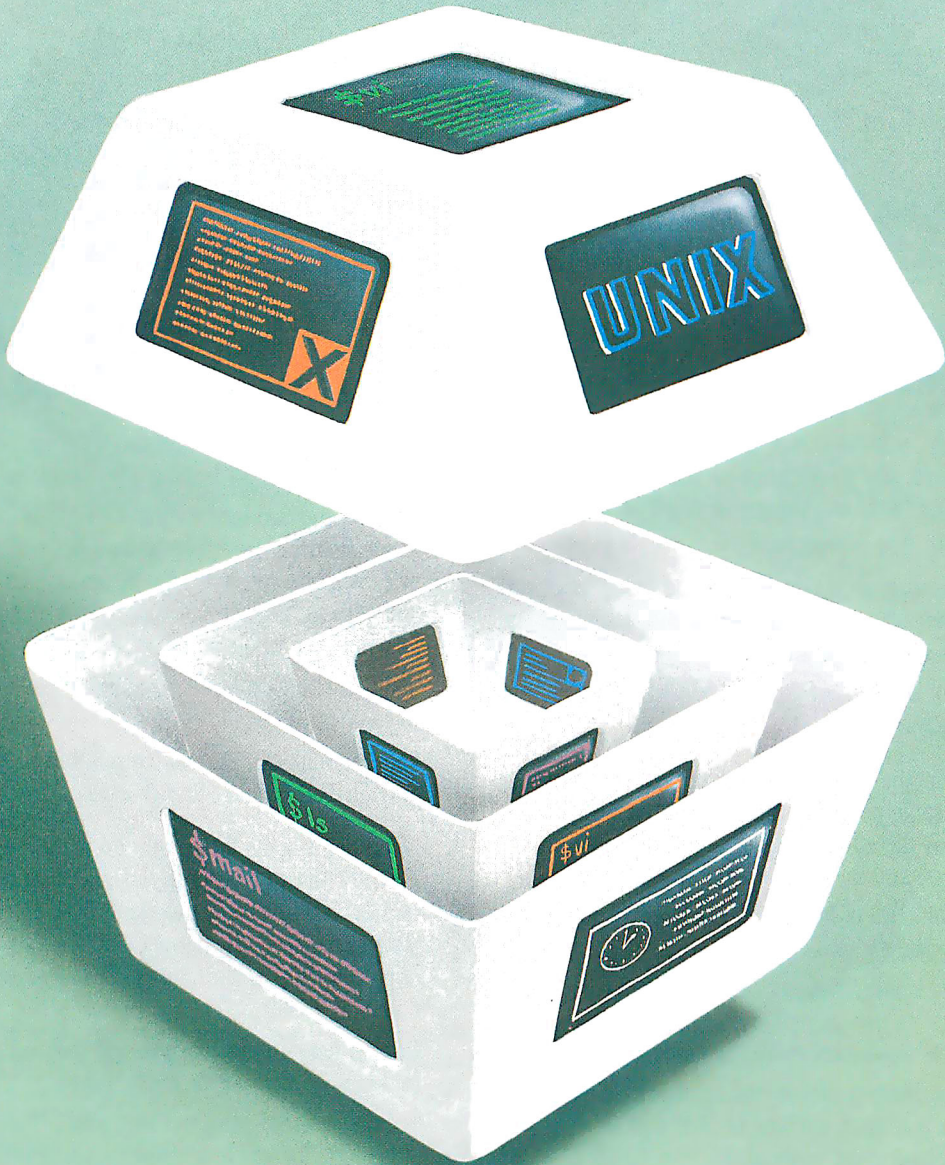

ROBERT
30 TINNEY



INSTANT MAINFRAME. JUST ADD SCO.

Not too long ago, a few dozen people sharing the same programs, resources, and information on a single computer at the same time meant only one thing—a mainframe.

Powerful, big, expensive, and proprietary.

More recently, the same people could be found doing exactly the same things—simultaneously sharing programs, resources, and information—on a minicomputer.

A lot cheaper, a lot smaller, yet powerful enough to do the same jobs. And just as proprietary.

Then along came the latest generation of personal computers.

And now, the same people are more and more likely to be found doing exactly the same things—simultaneously sharing programs, resources, and information—on a PC.

And not a whole officeful of PCs networked together, either, but *a single PC powering the whole office at once.*

A lot cheaper, a lot smaller, yet still easily powerful enough to do the same jobs. Built to non-proprietary, open system standards that allow complete freedom of choice in hardware and software.

And running the industry-choice multiuser, multitasking UNIX® System V platform that gives millions of 286- and 386-based PC users mainframe power every business day.

The UNIX System standard for PCs—SCO.*

Today, SCO UNIX System solutions are installed on more than one in ten of all leading 386 computers in operation worldwide. Running thousands of off-the-shelf XENIX® and UNIX System-based applications on powerful standard business systems supporting 32 or even more workstations—at an unbelievably low cost per user. And with such blazing performance that individual users believe they have the whole system to themselves.

Running electronic mail across the office—or around the world—in seconds.

Running multiuser PC communications to minis and mainframes through TCP/IP and SNA networks.

And doing some things that no mainframe—or even DOS- or AOS/2™-based PC—ever thought about, such as running multiple DOS applications. Or networking DOS, OS/2, XENIX and UNIX Systems together. Or running UNIX System versions and workalikes of popular DOS applications such as Microsoft® Word, 1-2-3®, and dBASE III PLUS.®

Or even letting users integrate full-featured multiuser productivity packages *of their choice* under a standard, friendly menu interface.

Today's personal computer isn't just a "PC" anymore, and you can unleash its incredible mainframe-plus power for yourself—today.

Just add SCO.

The SCO family of UNIX System software solutions is available for all 80286- and 80386-based industry-standard and Micro Channel™ computers.



(800) 626-UNIX (626-8649)

(408) 425-7222

FAX: (408) 458-4227

E-MAIL: ...!unnet!sco!info info@SCO.COM

UNIX is a registered trademark of AT&T. SCO and the SCO logo are trademarks of The Santa Cruz Operation, Inc. Microsoft and XENIX are registered trademarks of Microsoft Corporation. OS/2 and Micro Channel are trademarks of International Business Machines Corporation. 1-2-3 is a registered trademark of Lotus Development Corporation. dBASE III PLUS is a registered trademark of Ashton-Tate. 1/89
©1989 The Santa Cruz Operation, Inc., 400 Encinal Street, P.O. Box 1900, Santa Cruz, California 95061 USA
The Santa Cruz Operation, Ltd., Crowley Centre, Hatters Lane, Watford WD18 8JN, United Kingdom, +44 (0)923 816344. FAX: +44 (0)923 817781, TELEX: 917572 scoeuk

Circle 242 on Reader Service Card

IN DEPTH

Unix

- 
- 227 **Future Imperfect**
by David Fiedler

 - 237 **One Man's Experience**
by John Unger

 - 245 **The Unix Connection**
by Ben Smith

 - 253 **Safe and Secure?**
by Patrick Wood

 - 261 **Interrupts Aren't Always Best**
by George E. Pajari

 - 266 **Some Flavors of Unix**

With all the attention Unix is getting, you'd think it was a new product. It's not. It's been around for years. In fact, BYTE had an entire section devoted to Unix in October 1983. The attention it's getting now is due more to hardware than to software. In the 80386 and 68030, we finally have the hardware that makes using the Unix operating system on a microcomputer realistic.

Unix is not, however, just another operating system. It broadens the capabilities of the microcomputer to include the power of mainframes and minicomputers by using the very operating system that they use. However, if you decide to change to Unix, there are some things that you should keep in mind.

For one thing, Unix is a multiuser system. Whether you are one user on a small dedicated Unix system, or one of many on a huge Unix system, you must learn to think like a multiuser. This is not a problem. It's merely a mind-set. If you can learn to think like a multiuser, you'll open the doors to the capabilities of a multiuser system, whether or not you actually have one.

One element of this mind-set is the language used in discussing Unix: for example, *terminals*. We all understand what terminals are—many of us use them every day—we just don't tend to think of our own microcomputers as being terminals unless they're hooked up to a mini-computer or mainframe.

Another example is the use of *standard input* and *standard output*. On a large multiuser system, these definitions are extremely important; there must be a default location for input and output for control information on large systems. On a typical microcomputer, however, you can simply substitute keyboard and display screen, respectively.

There are other elements to this mind-set as well, and you'll discover many of them in this month's special In Depth coverage of Unix. We begin with "Future Imperfect" by David Fiedler, which shows how Unix began, what it is now, and where it's going. This article includes the text box "OSF/Motif" by John Paul, which gives an overview of this new graphical user interface from the Open Systems Foundation.

Next, in "One Man's Experience," John Unger describes the trials and tribulations—and rewards—of switching from DOS to Unix. In "The Unix Connection," Ben Smith describes various networking capabilities available to all Unix users, from the Usenet network to the UUCP tools to the NetNews BBS.

In "Safe and Secure?" Patrick Wood describes the pluses and minuses of the security features available on Unix. Then, in "Interrupts Aren't Always Best," George E. Pajari discusses when to use interrupts and when to use polling in designing device drivers.

The more you look at Unix, the more you realize that it deserves all the attention it's getting. A real Unix revival has occurred—at least in the microcomputer world. Makes you wonder what other revivals might be just around the corner.

—Jane Morrill Tazelaar
Senior Technical Editor, *In Depth*

**By popular demand, we've extended
this program to April 30, 1989.**

FREE* SIVA 386 SYSTEM

*with the purchase of \$3295++
of software or \$4995++ of
hardware.*

Standard 386 Features:

- 32-bit Intel 80386-16 CPU.
- 1MB of 32-bit RAM on board. System expandable to 16MB.
- 8/16/20 MHz Keyboard selectable.
- ST-251-1 Seagate 40MB Formatted 28 ms high speed, with ultra high speed Controller 1:1 interleave.
- 1.2MB High Capacity Floppy Drive.
- Super deluxe heavy duty tower case with 6 half-height drive openings.
- High-resolution 12" Non-Glare Amber Display. Tilt and Swivel base, Hercules-compatible Adapter.
- 101 Key Enhanced Keyboard, Pleasant "Tactile/Click" Feel.
- 80287/387 Math-Coprocessors optional.
- Fully compatible with virtually all XT/AT and 386 software.

Upgrades for your FREE 386 System:

- VGA Color Upgrade — add only \$495.
- 20 MHz CPU Upgrade — add only \$195.
- Call for all other options and upgrades.

Choose Your Hardware

*A hardware purchase of \$4995 or more is required
to receive the SIVA 386 System FREE.*

| | |
|--|--------|
| • QMS PS 810 Postscript Laser Printer | \$5495 |
| • CDC WREN IV 300MB SCSI Hard drive with Controller | \$2595 |
| • CDC WREN III 155MB SCSI Hard drive with Controller | \$1795 |
| • CDC WREN II 86MB ST506 Hard drive with HD/FD Controller | \$ 895 |
| • Eight Port RS232 Intelligent Card with Xenix Driver | \$ 995 |
| • 32-Bit 8MB Memory Expansion Board | \$2997 |
| • Intel 80387 — 16 Coprocessor | \$ 495 |

Software

| | |
|---|--------|
| • Complete SCO Xenix System (including Operating System, Developing System and Text Processing System for 80386-based System) | \$1595 |
| • SCO Lyrix System | \$ 595 |
| • SCO Professional | \$ 895 |
| • SCO Integra | \$1295 |
| • SCO Foxbase Plus | \$ 995 |
| • SCO VP/IX (integrated DOS environment — two users) | \$ 495 |
| • Language & Development Tools | CALL |
| • Networking & Communication Packages | CALL |

*A software purchase of \$3295 or more is required to receive
your FREE SIVA 386 System. Mix and match to meet
your needs!*

Ask about our Professional Services:

- Data Processing and Network Consulting
- Application Development and Training
- System Administration
- Hardware and Software Installation & Support

1-800-252-4212

VNS America Corp.

Suite 270, 910 Boston Post Road
Marlboro, Massachusetts 01752 U.S.A.
In Massachusetts 508-481-3726
FAX: 508-481-2218

All prices subject to change without notice.

Circle 284 on Reader Service Card

Future Imperfect

*All the various Unixes are merging into one—
but will it run on a microcomputer?*

David Fiedler

Time flies when you're having fun. It seems like just yesterday that BYTE ran its first in-depth coverage of the Unix operating system. Back then (in 1983), the hardware state of the art was represented by the Motorola 68000 CPU, Unix System III was the current standard, and CP/M was still going strong.

While a great deal has happened since then, much of the technology has been evolutionary. The real surprises have been—and will probably continue to be—in the ways that people and companies interact with the technology, providing new platforms for others to build on.

Recent History: Hardware

The CPU that has most influenced the Unix system is unquestionably the Intel 80386. With this one chip, Intel has bridged the gap between DOS and Unix, as well as the gap between microprocessors and minicomputers. The ability of the 80386 to run PC-DOS programs while maintaining simultaneous respectable throughput under Unix has made 80386-based machines one of the fastest growing segments of the market. (Naturally, some

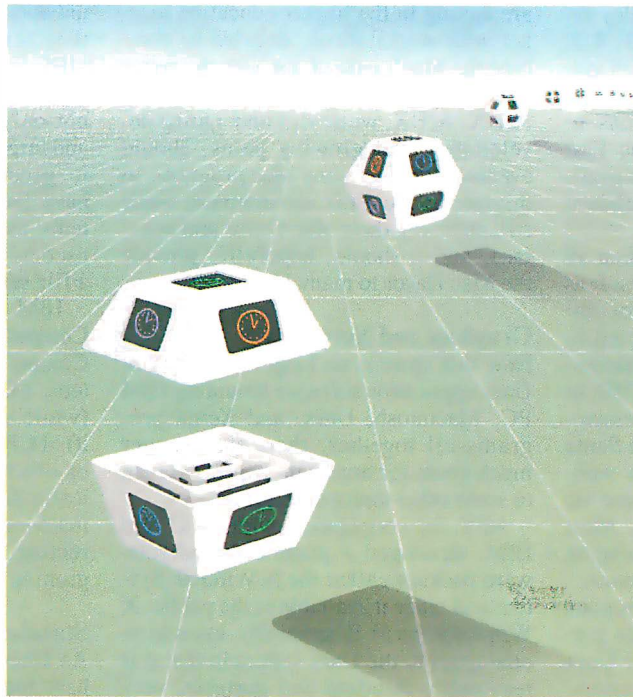

80386-based machines are being used for DOS applications alone, but it seems almost a waste of CPU cycles.) Once the 80386 became readily available to the personal computer user, it virtually took over the low end of the Unix hardware market.

Among other classical architecture machines, the leader is the Motorola 68030, a very fast chip whose impact is

just being felt in the Unix market. Certainly the effect of all its predecessors (the 68020, 68010, and the venerable 68000) has been great, especially in the scientific workstation market. And just as the Intel design has its followers in the IBM PC and compatible world, so the Motorola chips have been used to good advantage by Apple in the Macintosh line.

The biggest fad in chip design these days is RISC. What surprised most of the old-line companies is that RISC can deliver what it promises: higher speed of execution in exchange for slightly larger executables. The idea is that you restrict the instructions that a CPU can execute to the most common ones. By having a smaller instruction set, less time is spent in the processor's operations decision tree, and throughput is increased.

While the concept isn't new (remember Forth?), it pays off in a big way when applied to the eternal problem of putting a lot of CPU on a little piece of silicon. Innovative companies like Pyramid Technology, MIPS Computer Systems, and Sun Microsystems with its SPARC design (actually, even IBM's RT PC is

continued

RISC-based) led the way with undeniable proof that RISC was viable. Digital Equipment Corporation (DEC), AT&T, IBM, and Data General are now also committed to the RISC concept, as are traditional chip manufacturers Intel (the 80860) and Motorola (88000 CPU). The fad is becoming the norm.

Software

Despite the many protestations to the contrary, whatever is the current AT&T version of Unix becomes the standard to which all other systems are compared. Presently, that is Unix System V release 3.2. Its features include demand paging, shared libraries, STREAMS (a generalized network-interface facility), and RFS (for Remote File System, which is similar to Berkeley's Network File System). SVR3.2 for the Intel 80386 CPU merges Unix and Xenix functionality for the first time, enabling 80386 Unix application software to be sold as a commodity item, as MS-DOS programs are.

However, BSD Unix, based on a modification of Unix made at the University of California at Berkeley, makes up a large portion of the Unix market. Berkeley releases are generally numbered 4.1, 4.2, or 4.3 (the most recent). The SunOS system is based on Berkeley 4.3 Unix. Berkeley brought many innovations to Unix, such as symbolic links, the Fast File System, and NFS. Due to its availability, it has become a de facto standard in the academic community.

Xenix is the third main division of Unix. Created originally by Microsoft as a commercial product for microcomputers, Xenix itself has been ported to machines ranging from large minicomputers, such as the DEC VAX-11/780, to the IBM PC. Xenix has been aggressively marketed and supported by The Santa Cruz Operation and has gained a well-deserved reputation as a solid base on which to put application software. Most of today's Xenix systems are running on the IBM PC AT or 80386-based clones.

For years, computer industry pundits have been raising a lot of dust with predictions about whether PC-DOS or Unix will be the leading operating system. Even to ask the question is silly, since DOS and Unix have been almost mutually exclusive: DOS is for single-user PCs based on the 8088, 80286, or 80386 CPUs, while Unix is a multitasking, multiuser system that runs on virtually any CPU architecture up to a Cray supercomputer (imagine porting DOS to a Cray if you still don't think it's a silly question).

Although DOS and Unix aren't poten-

tial competitors in the market, OS/2 and Unix are (although OS/2 is still limited to Intel architecture). One of the advantages of OS/2 will be its upward compatibility from DOS. While relatively few people are working with OS/2 in the office environment right now, there are many happy DOS users on Unix and Xenix systems.

These users are happy because they're running their DOS applications—using the virtual 8086 capabilities of the 80386 CPU (via VP/ix or Merge 386) or using software emulators or converters (Soft PC or XDOS) on other CPUs—and they're doing it without leaving the Unix environment. This gives them the ability to move files between DOS and Unix, use the greater power of Unix for other tasks, and simplify system administration and backup. In many cases, their programs actually run faster than they would under native DOS. This upward compatibility is of a higher order than you usually expect.

If you're a Mac fan, all this talk about DOS probably leaves you cold. Apple, noticing the success that Sun and others are having in the higher-education market with workstations, decided to combine the Mac's ease of use with the popularity of Unix in the Mac II running A/UX. A/UX, while still undergoing development and growing pains, should eventually allow many Mac programs to migrate to the Unix environment while still retaining their Mac flavor and interface, and it should, hopefully, provide the Mac flavor to many Unix tools.

Graphics and Networks

Now that there is no longer a scarcity of Unix application software (counting IBM PC, Macintosh, Unix, and Xenix programs all together, there's no longer much room for argument here), I'll turn to some other topics of interest.

MIT, in cooperation with DEC and IBM, developed a graphics-based software package called the X Window System and made it available to the public. X Windows (as it is generally known) is analogous to the Unix system in that it is reasonably standard and portable, very well written, and serves as a base for other software. While not an entire user interface on its own, X Windows allows you to write applications that can interface with any computer supporting X Windows by simply recompiling.

Due to its availability, X Windows has spread widely and is now the de facto standard in the Unix workstation market. It has also been ported to the IBM PC under DOS and 80386 PCs running

Unix and Xenix (Xsight from Locus), as well as DEC machines running VMS. Acer has produced a graphics terminal with X Windows server code embedded in the ROM, obviating the need for a separate computer or workstation for the users of X Windows applications.

But X Windows isn't just graphics. It's also a networking package that allows you to run application programs, possibly located on different computer architectures on the same network, from one bit-mapped display. X Windows manages your display, keyboard, and mouse while transparently sending data via TCP/IP protocols to the other machines or programs as needed.

Another popular graphics and networking package is NeWS (Network Extensible Window System) from Sun. NeWS is based around the PostScript language, which means that less data can be moved across a network for the same graphical results. Sun is making NeWS compatible with X Windows.

Berkeley Unix introduced the Network File System concept. Using NFS allows file systems located on separate networked machines to appear as though they're all on one much larger computer. NFS, due to its availability, has become the de facto standard for networking—not only on Unix, but on workstations and larger systems (such as DEC's VMS) in general. It has become common to have IBM PCs networked to Unix systems using NFS; the PCs can then be used as terminals, or the Unix system as a file server, or both.

IBM has introduced the Transparent Computing Facility, developed by Locus Computing, for its AIX operating system. TCF goes a step further than NFS (while still retaining compatibility with it). TCF will actually run your programs on other networked computers, automatically finding the fastest or least-loaded machine, transferring files, and redirecting I/O as necessary. This is the beginning of true distributed computing.

Standards

As Unix has become ubiquitous, people have found the existence of multiple versions a barrier, especially for program development. Standards, such as SVID, POSIX, and X/Open, attempt to define certain characteristics a system should have, as a minimum, to be considered conforming. This would enable a developer relying only on these system requirements to be assured that the program will run properly on a Unix, Berkeley, Xenix, or any other POSIX-

continued

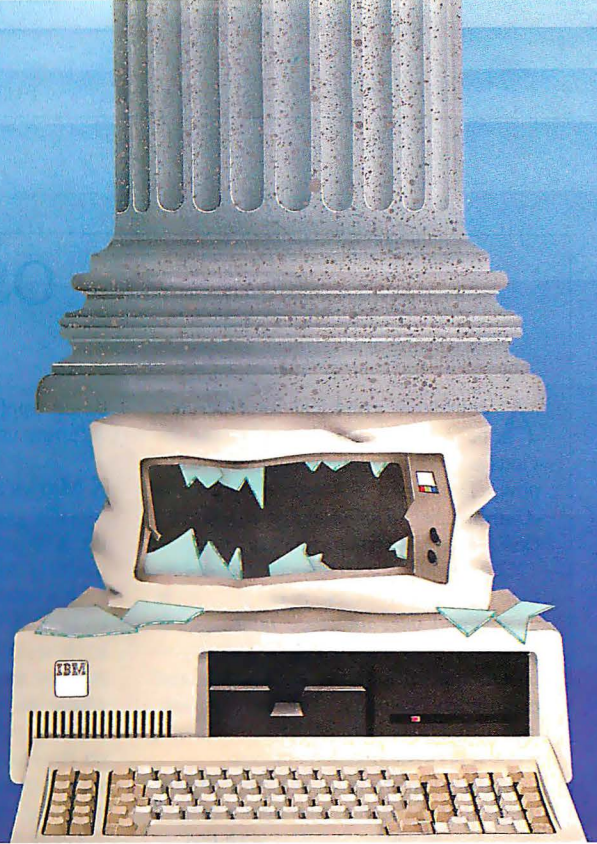

QNX[®] vs. UNIX OS/2

Architecture can make or break a computer system.

Don't make your systems bear the brunt of massive, monolithic monsters like Unix or OS/2. Instead, build your systems with QNX. The lean, efficient OS that's flexible enough to support any application.

MULTIUSER, MULTITASKING, NETWORKING, AND MORE... QNX is both multiuser *and* multitasking. OS/2 isn't multiuser. Unix may be multiuser and multitasking, but it will hog a huge chunk of your hard disk and system memory. And neither Unix nor OS/2 can do integrated networking.

QNX, on the other hand, hums along using an efficient 150K of RAM, yet provides a powerful multiuser, multitasking, and integrated networking environment.

TRUE DISTRIBUTED PROCESSING. A QNX-based PC LAN lets any user share *any* resource on the network—programs, data, devices, even CPUs—without going through the bottleneck of a central file server. With QNX you get mainframe power at micro prices.

ADDED VALUE FOR VARS. QNX is flexible enough to run on *any mix* of

PCs, ATs, PS/2s, with or without dumb terminals. Even diskless workstations are supported. So whether you start small or grow to mainframe proportions, you can easily build and maintain powerful, fault-tolerant systems without spending a fortune on hardware.

REALTIME PERFORMANCE. Only QNX combines the performance of a dedicated realtime executive with the convenience of a rich development environment that includes a host of utilities, C compiler, full-screen editor, symbolic debugger, and multiple full-screen windows.

DOS SUPPORT. For those who need their daily dose of DOS, QNX allows a DOS application to run as a single task on each PC on the network.

FREE TECHNICAL SUPPORT. While users of other operating systems have to cough up hefty fees for support, QNX developers enjoy *free* hotline support and *free* BBS access. You'll get prompt answers to your questions and you'll share ideas and insights with fellow developers in the QNX community.

It's time to make the move to QNX.

THE ONLY MULTIUSER, MULTITASKING, NETWORKING, REALTIME OPERATING SYSTEM FOR THE IBM PC, AT, PS/2, AND COMPATIBLES

| | |
|------------------------|---|
| Multuser | 10 (32) serial terminals per PC (AT) |
| Multitasking | 64 (150) tasks per PC (AT) |
| Networking | 2.5 Megabit token passing. 255 PC's and/or AT's per network. Thousands of users per network. |
| Realtime | 4,250 task switches/sec (AT). |
| Message Passing | Fast intertask communication across the network. |
| C Compiler | Standard Kernighan and Ritchie. |
| Flexibility | Single PC, networked PC's, single PC with terminals, networked PC's with terminals. No central servers. Full sharing of disks, devices and CPU's. |
| PC-DOS | PC-DOS runs as a QNX task. |
| Cost | From US \$450. Runtime pricing available. |

For further information or a free demonstration diskette, please telephone (613) 591-0931.

Circle 221 on Reader Service Card

Quantum Software Systems Ltd. • Kanata South Business Park • 175 Terrence Matthews Crescent • Kanata, Ontario, Canada • K2M 1W8

OSF/Motif

John Paul

A consistent graphical interface has been one of the industry's most obvious and controversial problems—until now. The Open Software Foundation (Cambridge, MA) recently announced OSF/Motif, its first product offering.

OSF/Motif is a graphical user-interface toolkit, window manager, style guide, and user-interface language. It lets you create consistent graphics-based applications on both open and proprietary systems. The various elements that constitute Motif were chosen from vendor submissions to OSF.

Motif's interface behavior is compatible with Presentation Manager's behavior. Thus, if you're familiar with PM on personal computers, you can use Motif-

based applications without learning a different user interface.

X Marks the Spot

Motif's graphical interface is based on the X Window System from MIT. This underlying technology provides you with a network-based graphical user interface. X Windows has a server-client architecture. The actual application runs on the client side and can be anywhere in the network—on a Cray, a VAX, a specialized database processor, an Apollo workstation, and so on. The server runs locally on the workstation, personal computer, or X terminal.

Using the X protocol, the client and server communicate, making it possible

to run a simulation on a Cray in the network while all user interaction and graphical presentation appear on your workstation or personal computer.

Motif is composed of a style guide, window manager, interface toolkit, presentation description language and compiler, user documentation, application programmer documentation, and test applications.

- *Style guide.* The success of the Macintosh is attributed largely to the consistent look and feel of the applications that run on it. This consistency is what OSF, through Motif, hopes to bring to applications written by the rest of the computer industry.



Photo 1: An example of an OSF/Motif display. OSF/Motif combines the utility of DEC's XUI with the familiar look of Microsoft PM and the elegance of Hewlett-Packard's New Wave. (Photo courtesy of Kee Hinkley and Apollo Computer.)

The style guide, a joint Hewlett-Packard/Microsoft submission, describes a standard behavior and a set of conventions for applications, to ensure a consistent feel on multiple applications. It is compatible with Microsoft PM, which is already familiar to many PC users. The style guide includes extensions for powerful network-based workstations. Its "look" is based on the HP three-dimensional screen-button appearance (see photo 1).

- *Window manager.* An HP submission, the window manager lets you manipulate multiple applications on the screen and plays a principal role in enforcing the style guide. Although it provides standard PM behavior, the window manager is highly customizable; it lets you redefine the contents of the window-manager menus and alter other aspects of window-related interactions.

- *Interface toolkit.* The OSF/Motif toolkit, a DEC submission, is based on the X Windows intrinsics, a toolkit framework provided with MIT's X Window System. The intrinsics use an object-oriented model to create graphical objects known as *widgits* or *gadgets*. The specified widgits maintain consistency between applications.

DEC's toolkit (XUI) will be extended to support the three-dimensional appearance and PM behavior of the HP/Microsoft submission. It will be upwardly compatible with the current Digital Application Programmer Interface so that applications written today on XUI will move easily to OSF/Motif.

- *Presentation description language.* This language, using DEC's User Interface Language (UIL) compiler and resource manager, enables application developers to describe the presentation characteristics of the application interface independent of the actual application code. The separation between application and interface lets you make many changes to the overall appearance and layout of an application without having to modify, recompile, or relink the application itself.

Open Systems

OSF/Motif supports the major goals of the OSF by providing an interoperable, scalable, and portable application environment. Let's look at these features.

Interoperable systems are more than just networked computers sharing CPU cycles, memory, disk space, and I/O devices. In addition to sharing computer resources, users need to move freely between applications running on different computers and operating systems without having to learn a new user interface.

Many people believe that computing in the future will be dominated by personal computers on the desktop and Unix-based systems in the network. A typical user will run PM-based applications and network-based applications through an X server on the same personal computer at the same time. OSF/Motif, with its PM behavior, will let you do this without confusion—a major step toward linking the personal computer and open-systems communities.

Scalability allows both users and applications to run on a wide range of hardware, from personal computers to supercomputers. Today, when your application outgrows your computer's architecture and you move to a larger system, you usually need to relearn your application. In fact, you may not be able to use it at all. Motif is the first step toward allowing you and your application to scale to a more powerful, yet still familiar, environment.

Motif is built on standards such as POSIX, ANSI C, and X Windows, so it is portable to many different architectures. For example, within one day of receiving the DEC and HP code, the OSF had the software running on three different hardware platforms.

A Joint Effort

OSF chose to build Motif from two technologies. This decision allows Motif to have PM behavior and an advanced three-dimensional look implemented on the best toolkit available.

A joint team of OSF, DEC, and HP engineers is combining the two technologies. Motif's release is scheduled for this summer.

John Paul was recently made president of Nixdorf Computer Engineering Corp. From May 1988 to January, he was interim director of development for the Open Software Foundation. He can be reached on Usenet as "uunet!xait!emacs!jppaul" or on BIX c/o "editors."

conforming system. While X/Open is more international in scope than POSIX (a U.S. national standard sponsored by the IEEE), both enjoy plenty of support from manufacturers and are not exclusive of each other.

More controversial in some corporate circles is the concern that AT&T is in too powerful a position with regard to Unix. Even though AT&T licenses Unix source and binary code to its direct competitors, they claim that the control of Unix is too important to be left to one company and that Unix development should be an open process. Part of the controversy is due to the fact that several companies making this claim have historically made their money with proprietary operating systems that weren't open to anyone.

In any case, these companies have formed a consortium, the Open Software Foundation (OSF), and have been working on an operating system and user interface that will be available this year for anyone who wishes it. It is interesting to speculate on what impact the OSF will have on the industry at large. In the long run, the effect will certainly be fewer separate flavors of Unix. Its system, OSF/1, will be based on IBM's AIX and yet will still conform to Unix System V, POSIX, and X/Open standards. The promise of openness has brought the OSF many new members; this may, in time, dilute the original anti-AT&T posture.

Supporters of AT&T have come up with their own organization, Unix International, Inc. (UII), whose charter is to provide feedback to AT&T on software development, features, and licensing issues, although AT&T will always have the final say. Several companies have joined both UII and the OSF; their chief executives should be considered as potential political candidates.

Free Software

The purest of open systems philosophy is exemplified by the Free Software Foundation and the GNU Project. Richard Stallman (the originator of the popular EMACS editor) is the principal exponent of the movement to eliminate restrictions on copying, redistributing, and general distribution of information and source code for computer programs. Working principally off devotion to the project and grants from Hewlett-Packard and the OSF, the Free Software Foundation has produced some of the best compilers, editors, and utilities for Unix. As X Windows demonstrates, excellence and availability are the prime ingredients for de facto standardization.

continued



Reading worth writing for.

If you're looking for some good reading, you've just found it. The free Consumer Information Catalog.

The Catalog lists about 200 federal publications, many of them free. They can help you eat right, manage your money, stay healthy, plan your child's education, learn about federal benefits and more.

So sharpen your pencil. Write for the free Consumer Information Catalog. And get reading worth writing for.



**Consumer Information Center
Department RW
Pueblo, Colorado 81009**

A public service of this publication and the Consumer Information Center of the U.S. General Services Administration.

232 B Y T E • MAY 1989

Future History—Hardware

Let's look a few years ahead. Predictably, we'll have the Intel 80486 64-bit CPU, which will likely run at speeds of up to 40 MHz or more and have companion specialty chips to drive SCSI, graphics, and other devices at high speeds. These chips will be similar to main-frame channel controllers; perhaps one will appear to the bus like a bank of 80286 CPUs, for DOS compatibility requirements. The Motorola 68040 will be a leading competitor to the 80486, with similar specifications. Both CPUs will retain compatibility with earlier designs.

The new generation of RISC chips will bring extensions to both ends of the current spectrum. RISC technology will appear in lower-priced computers, while much larger machines will be made up of parallel high-throughput RISC processors. Parallel architecture will be more popular in general, with special on-chip logic signals to support synchronization between CPUs. One cabinet will hold a closely coupled network of processors, and your program might be executed on one or all of them (think of IBM's TCF in miniature).

Digital signal processor (DSP) chips will continue to grow in importance. In the Unix workstation market, they will be the key to driving voice I/O, as speech recognition emerges from the laboratory. But as they become more familiar to system designers, DSPs will be used in other interesting ways, since they are basically very fast floating-point RISC machines. Adaptive digital communications is one interesting idea to watch here.

Probably the best look you can get at the future of Unix systems is the visionary NeXT machine (see "The NeXT Computer" by Tom Thompson and Nick Baran, November 1988 BYTE). It's certainly ahead of its time (unavailable to business users, though, and currently only in limited distribution in its market of higher education) and will be used as a model from which future software and hardware developers can start.

The state of the art this year for Unix dial-up communications is the Telebit Trailblazer Plus modem, which has become a de facto standard due to its availability and features. It implements the UUCP protocol (and a few others such as Kermit, XMODEM, and YMODEM) and data compression in firmware, for real-world throughput of well over 1000 bytes per second.

Other high-speed modems using hardware data compression algorithms that automatically switch between fax mode

and data mode are on the horizon. In the future, these will all likely be supplanted by ISDN telephone service at 56 kbps. If ISDN is not priced carefully by telephone companies, look for intelligent radio (not cellular) modems that can pass information at high speeds over relatively short distances, using Unix systems as store-and-forward servers as is currently done with Usenet news.

Software

What most people are waiting for now is the release of AT&T's new Unix System V release 4.0. SVR4 will merge current Unix System V, SunOS, Berkeley 4.3, and Xenix system calls and commands in the most ambitious attempt ever to combine all major versions of Unix into one. SVR4 will include both NFS and RFS; STREAMS and Sockets; ASCII character and Open Look graphical interfaces; and X Windows 11 and NeWS. It will provide for real-time process scheduling, support for full international (multiple bytes per character) character sets, ANSI C, and dynamic linking, plus new system administration and security enhancements. Application Binary Interfaces (ABI) will mean that any program written for any 80386, SPARC, or other ABI machine running SVR4 will run properly.

Farther into the future, there will be a standard for electronic documents that combines sound (voice), graphics, and text in E-mail for every popular computer architecture. Such heavy communications traffic loads will require multitasking (and probably multiprocessor) systems and will make single-tasking systems such as MS-DOS and the Macintosh operating system all but obsolete.

User Interface

It's not inconceivable that, in the foreseeable future, nonintuitive interfaces will disappear altogether. Those of us who have grown up with computers in the last 25 years or so may think that the standard shell-type interface is intuitive, but it isn't. Most people can relate to pictures better than to letters and numbers. Graphics is the wave of the future, and there's a big interest in portable graphical interfaces for Unix.

OSF/Motif, the graphical interface selected by the OSF (see the text box "OSF/Motif" by John Paul on page 230), combines offerings from DEC, Hewlett-Packard, and Microsoft. It has the look and feel of Microsoft's OS/2 Presentation Manager and MS-DOS Windows, with the three-dimensional appearance

continued



How to match the best front end with the best back end.

You've invested in the best hardware, operating system and database products. You have a staff of programmers ready to go. But to build great looking applications with the sophisticated features

today's users demand, you need a powerful front end development tool—JAM™. JAM, the most advanced user interface management system on the market, does it all—from prototyping to implementation.



Create colorful screens and nested windows easily.

And, because it works with any database or file manager, you get the best front end *and* the best back end.

JAM is hardware independent, so it isn't limited to one computer, database or operating system. In fact, JAM runs on everything from PC's to super-minis, works under 7 operating systems and provides access to a host of database products. Using JAM you can create a consistent user interface across multiple systems and hardware platforms.

JAM works under the following operating systems:

- UNIX®
- VMS®
- RMX™
- MS-DOS®
- XENIX®
- VOS™
- AOS/V5™

JAM makes it easier than ever to design and revise complex applications. Using features like context-sensitive help, procedural command language (JPL), shifting and scrolling fields, extensive data validations, on-line testing, and a variety of visual attributes, you'll be amazed how quickly your applications spring to life.

JAM is fast, as well as flexible. Development time is reduced significantly thanks to JAM's powerful screen drawing utilities and comprehensive library of sub-routines. You can easily create and link together screens, windows, and menus to develop an application shell. Then simply attach the processing routines, and your application is complete.

Plus, if your back end is an SQL-compatible relational database like Oracle®, SQLbase®, Informix® or Britton Lee™, you'll really appreciate JAM/DBi, JAM's optional database interface. With JAM/DBi, you can develop entire applications using only industry-standard SQL statements and JAM's authoring tools.

So if you're programming in a 3GL like C or FORTRAN, follow the lead of the many Fortune 1000 companies who have already discovered JAM.

JAM from JYACC. It gives you the best at both ends.

Call for more information about JAM and our demo diskette.

800-458-3313
JYACC, Inc.
116 John Street
New York, NY 10038
212-267-7722 FAX No. 212-608-6753



Use SQL to retrieve and display data.

JAM

JYACC Application Manager. *The Composer for Sophisticated Applications.*

developed for HP's Window Manager. All this runs on top of X Windows. Its reasonable licensing terms, extensibility, and wide availability should make OSF/Motif a very important product in the next few years.

In the other camp, AT&T has been demonstrating its Open Look interface, which runs on top of either X Windows or NeWS. Developed with Sun and licensed, in part, from Xerox, Open Look will be the standard graphical interface

from AT&T and followers for Unix SVR4. This alone makes it an important force in the market, even though direct support for Open Look has not been as forthcoming as support for OSF/Motif.

NeXT's NextStep is the graphical interface on the NeXT machine. It is object-oriented and has a three-dimensional appearance, and it also supports Display PostScript. While it isn't being offered in the same way as the other products mentioned, NextStep's wide distribu-

tion on campuses will influence users' experience. IBM has licensed NextStep as a possible new interface for AIX.

The ultimate choice of a graphical interface for Unix is an important one, but the choice must be made soon, lest "look and feel" lawsuits choke off all progress toward standardization.

A Word on Standards

As noted, many products have become market leaders or de facto standards because they were quickly made available to a wide spectrum of machines. This kind of migration is the real impetus behind open systems. When external organizations attempt to impose standards, they generally succeed in direct proportion to how well they follow what the market is already demanding (remember Esperanto?).

We can hope that once all the various Unices are merged into one "ultimate" standard version, the result will not be so cumbersome that a supercomputer will be needed to run it (unless, of course, supercomputer chips cost only \$50 each by that time).

One Final Glimpse into the Future

What does the future hold? I can imagine this clipping from BYTElines, April 1996:

"Unix System XII release 9.01, from AT&T/Trump Software, is soon to be released. It promises to merge the leading versions of Unix from the U.S., Japan, and the Soviet Union. Controversy arises over whether the kernel (written in C++++++) should be smaller than 16 megabytes, to allow use on older systems. Computer tabloids argue whether Unix will ever be accepted in the marketplace, since there are only 6.02×10^{23} application programs available for it and it's still not DOS compatible.

"Critics of AT&T/Trump complain that the new release is not open enough and that it won't be available to the public for a full 52 minutes after internal certification (and then only by slow 100-megabyte-per-second network feeds). Richard Stallman, AT&T/Trump Vice President of Software Social Responsibility, disagreed on worldwide digital television and was supported by a majority vote on Usenet 27 seconds later." ■

David Fiedler (alias the "dragon" of InfoPro Systems, Rescue, CA) is the publisher of the Unix newsletters UNIQUE and ROOT, and coauthor of the book Unix System Administration. He can be reached on the UUCP network as "info-pro!david" or on BIX c/o "editors."

HOW DO YOU GET A JOB WITHOUT EXPERIENCE? AND HOW DO YOU GET EXPERIENCE WITHOUT A JOB?

Most young people have one answer to this problem. They avoid it until they're out of college. But they could be getting solid work experience while they're still in college. With your company's help. And ours.

We're Co-op Education. A nationwide program that helps college students get real jobs for real pay, while they're getting an education. But we can't do it without you.

Those real jobs have to come from real companies. Like yours.

For more information on how you can participate in this valuable program, write Co-op Education, Box 775E, Boston, MA 02115.

Not only will you be giving students a chance to earn money and pick up the most valuable kind of knowledge, you'll be giving yourselves a chance to pick up the most valuable kind of employee.

Co-op Education.

You earn a future when you earn a degree.



A Public Service of This Publication ©1987 National Commission for Cooperative Education

Telebit's T1000. The only other UNIX modem.

Now there's another high-speed, dial-up UNIX modem. The T1000. From Telebit.

The T1000 modem transmits data at 9600 bps. For the price of most 2400 bps error-free modems. And like Telebit's 19,200 bps modem, the T1000 offers full internal support for the UNIX UUCP protocol. Which means our modems run 4-10 times faster than any other modem.

So now there's a choice. A choice for any budget. The 9600 bps modem. Or the 19,200 bps modem. Both fully compatible. Both from Telebit.

Totally Plug-Compatible, Too.

Whichever modem you choose, you'll get total plug-compatibility with UNIX and XENIX. Just unplug your old modem and plug us in. Without even changing software.



Both modems work with every UNIX hardware and software manufacturer, too. AT&T, Sun and Santa Cruz Operations, Altos, Apollo and Apple. Convex, Cubix, DEC and HP. Interactive Systems, Masscomp and Microport. Microsoft, NCR, Pyramid, Sequent, Stratus, Tektronix and Unisys. All of them.

And you'll get improved performance. Imagine remote *vi* as fast as your direct connections. Send *mail*, do file transfers or *cu*. Or remotely access your network with *TCP/SLIP*.

Both Telebit UNIX modems are perfect for connecting remote locations to LANs. Or transferring any large data file.

So get the only other UNIX modem. The T1000. Or get our other modem for even higher performance. Both are the best in UNIX. And both offer the best prices. Call Telebit at 1-800-Telebit or (415) 969-3800. Or write 1345 Shorebird Way, Mountain View, CA 94043-1329.

Because no one gets the message through like Telebit.

T1000.



© 1988 Telebit Corporation. Telebit is a registered trademark and PEP is a trademark of Telebit Corporation. Other brands or product names are trademarks of their respective holders.

optional stand

Circle 262 on Reader Service Card



There is
no need to
compromise.

Come to Control
for all your
multiuser board
solutions.

DEMAND THE LATEST TECHNOLOGY

From the first multiuser serial board for the PC™ in 1982 to the first multiuser serial board for the PS/2™ in 1987, CONTROL offers you the latest technology to keep you on top of things. Our full-time staff of programmers insure drivers for compatibility with the latest software. We include drivers free with each board sold.

YOU DESERVE THE BEST SUPPORT

You pay no more for lifetime support at CONTROL. Call toll free and talk to engineers, programmers, technicians, and managers. Our **30 day money back guarantee** tells you we stand behind our products with confidence. Our satisfied customers keep buying our boards.

GET MINI PERFORMANCE AT A MICRO PRICE

Whether you need additional ports for your 386, AT™-clone, or IBM PS/2™ CONTROL is your multiuser hardware link. Don't pay extra for more power than you need. Meet your price/performance specifications. With our family of products, you can match the power to your project:

- **HOSTESS™** and **HOSTESS/MC™** a non-intelligent board for low-end multiuser systems
- **HOSTESS 550™** and **HOSTESS 550/MC™** a board with buffering to increase performance
- **ULTRA 186™** multiple ports with intelligence on board to off-load the system CPU
- **SMART HOSTESS™** and **SMART HOSTESS/MC™** the high performance intelligent multichannel board to design your custom application.

There is no need to compromise. Buy Control's **HOSTESS™ & MC Master Communicator™ Multiuser Serial Boards.**

Call toll free or write for information.

Control Corporation
2675 Patton Road P.O. Box 64750
St. Paul, MN 55164

OEM pricing and Dealer discounts available.

Call 1-800-333-1033



PC, PS/2, and AT are trademarks of the IBM Corporation. HOSTESS, HOSTESS/MC, HOSTESS 550, HOSTESS 550/MC, ULTRA 186, SMART HOSTESS, SMART HOSTESS/MC and Master Communicator are trademarks of Control Corporation.

One Man's Experience

*The trials and tribulations
of switching from MS-DOS to Unix*

John Unger

About 18 months ago, I decided I would have to bite the bullet and trade in my trusty IBM PC AT for a Unix workstation. It was not an easy decision to make.

During the past seven years, I had progressed from CP/M through MS-DOS and had gradually weaned myself away from larger computers almost completely. I was doing the bulk of my scientific programming and number crunching on my AT using programs I had written in C. When I needed a larger computer, I used terminal-emulation software on the AT that made it work like a DEC VT-100 or a Tektronix graphics terminal, and then I logged onto the nearest minicomputer. But I was coming to an impasse.

First, I had to have more computing horsepower on my desktop, specifically to run larger programs that use high-resolution color graphics. Second, I needed to run commercial software that either was not available for MS-DOS computers, ran too slowly on them, or was crippled in the MS-DOS environment. Also, I wanted to be able to network transparently with the new powerful Unix file-and-compute servers that

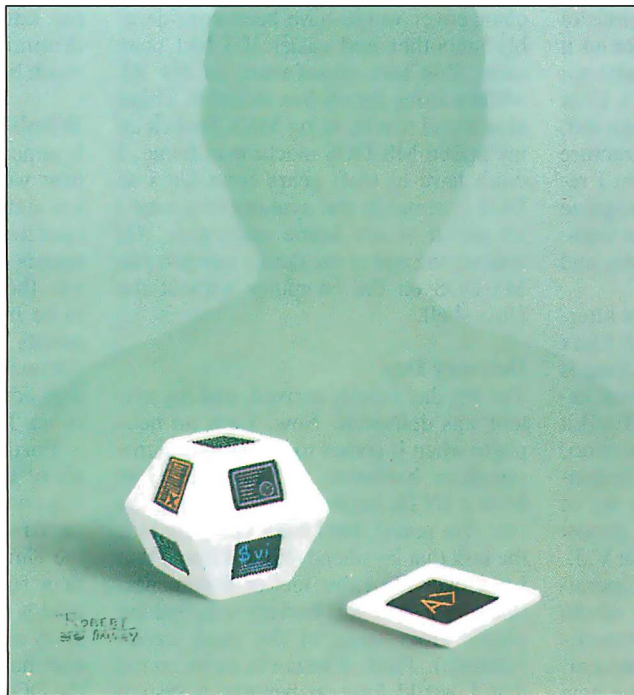

we planned to acquire where I work. I needed a workstation.

Making a Choice

When I actually sat down to figure out what hardware to buy, two factors became obvious: The workstation had to have a Unix operating system and some sort of MS-DOS emulation. I chose Unix because it has become the de facto stan-

dard for scientific and engineering workstations and for the software that runs on them, and because I wanted my workstation to be able to communicate over a local Ethernet network with large Unix computers as easily as possible. However, because I do much of my work at home on my Dell System 200 80286 MS-DOS machine, I still had to interface with that environment and had to be able to move files back and forth between Unix and DOS.

I finally decided on a Sun-3/110, which runs SunOS, a version of Unix very much like BSD 4.2, and SunView, a windowing environment that enhances multitasking in Unix and makes the system a little more user-friendly. I ordered my computer with one of Sun's interprocess communications (IPC) AT-emulation

boards installed in its backplane to give me MS-DOS compatibility through a DOS window in the SunView environment.

Although I was experienced with C, all my programming had been on CP/M and MS-DOS microcomputers and non-Unix minicomputers; I had never been either a user or a programmer on a Unix

continued

Table 1: A list of some of the more common DOS commands and their Unix counterparts. Notice that while some Unix commands are virtually identical to the DOS commands, others give different results and, in general, have the option of using command-line arguments to enhance their power and versatility.

| DOS command | Unix command | Description |
|-------------|---------------|--|
| DIR | ls -al | Directory listing with file data, such as creation date and size |
| DIR/W | ls | Simple list of filenames arranged in columns across the screen |
| DIR/P | ls -al more | List of filenames, one screen at a time |
| DEL | rm | Delete files |
| TYPE | cat | Display contents of an ASCII file on the screen |
| COPY | cp | Copy files |
| RENAME | mv | Rename files or (Unix only) move file to a different directory |
| MKDIR (MD) | mkdir | Make a new directory or subdirectory |
| RMDIR (RD) | rmdir | Delete an empty directory or subdirectory |
| CHDIR (CD) | cd | Change the working directory |
| FIND | grep | Locate ASCII strings in a file |

system. So, to prepare myself for the change, I read books about using Unix—an exercise that was largely a waste of time until I got my machine. I found it extremely difficult to learn without doing; I needed to sit in front of a Unix computer to learn Unix. The books did, however, acquaint me with the structure of the operating system, and when I received my computer, I could recognize some of the more common Unix commands, if not use them intelligently and elegantly.

A more reasonable, inexpensive alternative for getting acquainted with Unix while working on your DOS machine is to use a Unix shell program. The best example I've found is the MKS Toolkit from Mortice Kern Systems (Waterloo, Ontario, Canada). It includes an operating-system shell program and a set of about 130 utility commands that almost perfectly mimic AT&T Unix System V.3.

The MKS Toolkit is not a Unix operating system like Xenix for your 80x86 microcomputer; it won't let you do multitasking or have a multiuser environment. The MKS Toolkit only adds some new commands to DOS and replaces MS-DOS's COMMAND.COM with a command-processor program that looks and acts much like a Unix "Korn" shell interface. With this package you can actually use the common Unix commands and become familiar with the Unix environment while still sitting in front of your comfortable MS-DOS microcomputer with DOS only a keystroke or two away.

Unfortunately, I wasn't aware of the

MKS Toolkit when I was making the transition from DOS over to Unix. My changeover would have been considerably smoother and easier if I had been using this sort of software on my AT while waiting for my Sun to arrive. I have also found that by using MKS Toolkit on my 80286 MS-DOS machine at home, I don't have to shift gears from Unix to DOS commands and syntax every time I sit down at my home computer. Of course, the rest of the family can just run MS-DOS on the computer without the Unix shell.

Delivery Day

The big day finally arrived, and my system was delivered. Now, I am no neophyte when it comes to installing microcomputer hardware and software (I've been a BYTE hardware reviewer for the past five years), but I wasn't prepared for the task that lay ahead. First, I found that I had over 2½ cubic feet of documentation to digest (I still haven't removed the plastic from some of the more exotic manuals). Then, it began to dawn on me that I would have to become a system manager for a *real* computer.

I shouldn't have been so surprised. After all, this desktop workstation is as powerful as the VAX minicomputer that I had occasionally logged onto with my AT, and that computer had required a full-time system administrator and professional monthly maintenance to keep it healthy. I obviously had a difficult job ahead. I was going to have to learn more about the nuts and bolts of the Unix oper-

ating system than the average user does.

This situation is, I suspect, more the exception than the rule for the majority of new Unix users. Many Unix workstations are used as stand-alone systems or as single-user systems networked into an Ethernet LAN, which means you'd have to be concerned with the nitty-gritty chores of setting up your system and keeping the operating-system software properly maintained and backed up.

Fortunately, Sun has a toll-free number for free software and hardware support during the warranty period, and it is accustomed to helping people like me through the process of getting a system up and running. Still, I spent two full days getting the hardware connected and configured properly and the operating-system software loaded. In all fairness, I should admit that I spent a good part of this time reading the Sun system-installation and maintenance manuals.

Finally, I flipped the power switch, logged onto my new computer for the first time, and was greeted by the notoriously user-unfriendly Unix prompt. At this point, real panic set in; the extent of my knowledge of Unix, gained from skimming some Unix books, didn't go much beyond `cat` and `ls`.

Who's in Command?

It appeared that my productivity on the new workstation was going to be very low until I learned more about the Unix operating system, what its terse commands did, and how to use software like `vi`—the ubiquitous Unix editor. It's easy to be intimidated by Unix and its commands. Where MS-DOS has 50 or 60 commands and utility programs, Unix, depending on the version you use, has between 150 and 250 specific commands.

Fortunately, you don't have to learn all of those commands at once (even if you could) to get the feel of Unix. One of the first things I did was experiment with the Unix commands that seemed closest to or functionally equivalent to the commands that I most commonly used in the DOS world. To help me understand these commands better, I made a short list of the DOS commands and their Unix counterparts (see table 1).

There are some slight but important differences between the pairs of commands. For example, you can use the Unix `mv` command to move a file to a different directory as well as to give it another name in the same directory.

One distinction between DOS and Unix that bugs me is that Unix uses the slash as a delimiter, as in

continued

The UnVT

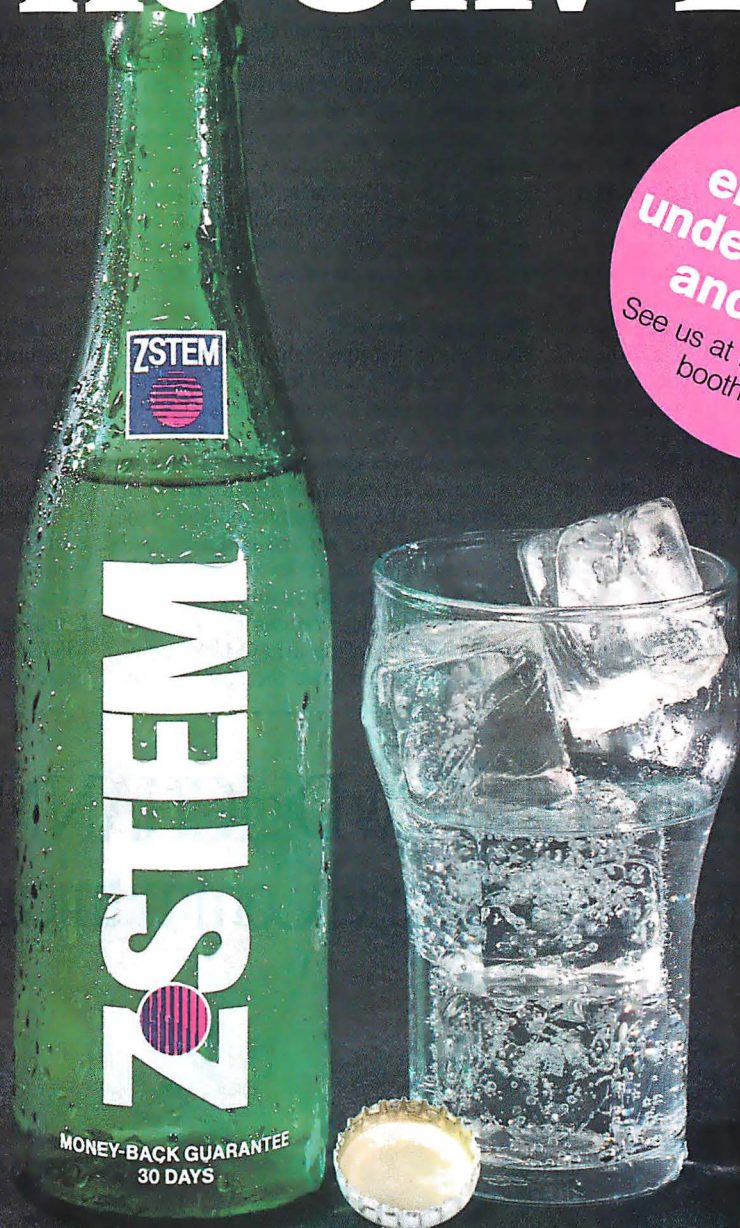

VT240
emulation
under MS-DOS
and UNIX.
See us at Dexpo South
booth #1112

Terminal emulation on your PC. The clear alternative to DEC terminals!

In today's computing world a VT terminal is no longer enough. Your users need an alternative. They need ZSTEM, the UnVT. ZSTEM 240 is the fastest VT240 terminal emulator available, bar none. And it comes equipped with a list of features to satisfy any discerning user:

- ▶ 132 columns on all graphics adapters
- ▶ 16 color ReGIS graphics
- ▶ full VT340 resolution on standard VGAs
- ▶ VT340 mouse and graphics tablet support
- ▶ extensive network support
- ▶ optional VT200 layout keyboard

But don't just take our word for it. Phone today for a free demo and find out why Digital News says "its performance is as perfect as an emulator can get."



KEA Systems Ltd. • Telephone: 604-732-7411 • Fax: 604-732-0715 • Toll free order desk: 800-663-8702
2150 West Broadway, Suite 412, Vancouver, B.C., Canada V6K 4L9. PowerStation and ZSTEM are trademarks of KEA Systems Ltd. All other brand and product names are trademarks or registered trademarks of their respective holders.

```
cd /usr/junger/byte/unix_dos.rev
```

while DOS uses the backslash character for the same purpose:

```
cd c:\junger\byte\unix_dos.rev
```

Another major difference to keep in mind is that Unix's command-line parser is case-sensitive; in other words, the commands DIR, Dir, and dir would all be different in Unix.

In many cases, the Unix commands can take arguments that extend their meanings and give them more power and flexibility than their DOS counterparts. For example, in Unix, `rm -i filename` deletes the file only after you respond with a `y` to a prompt asking you to confirm the deletion (much like DOS does when you use the command `DEL *.*`).

Beware the powerful Unix command `rm -r directory`, which recursively deletes the directory given in the argument and all the files and subdirectories in that directory. Use this with great care.

Also, Unix's `grep` and DOS's `FIND` are superficially similar utility programs, but you can extend and fine-tune

`grep` with an entire suite of arguments and regular expressions.

The wild-card characters `*` and `?` have almost the same meanings in DOS and Unix, but there are subtle differences. For example, the DOS commands `DEL *` and `DEL T*` will delete the file `TEST`, but neither one will delete `TEST.DOC`. In Unix, either `rm *` or `rm t*` will delete both `test` and `test.doc` files. In the logic of Unix filenames, the `."` character is just like any other character; it is not a special delimiter used between a filename and its extension, as in DOS.

Weaning Yourself

One option that may help with the DOS-to-Unix transition is Unix's `alias` command; it lets you give an additional name to any Unix command-line string. This command takes two character strings as arguments. In its simplest form, the first argument is the new command you want to define, and the second is the normal Unix command or series of commands that the first string will mimic.

As an example, you can enter `alias dir ls -al` to define a new Unix command, `dir`, to produce the same listing

of files that the command `ls -al` does. Your Unix system will now understand the `dir` command. But eventually you will want to master the Unix utilities themselves to use Unix to its best effect. Thus, as soon as it's feasible, you should wean yourself away from crutches like DOS-type aliases.

Because I had installed the Sun IPC board, I could still work in the MS-DOS environment on my new Unix workstation much the same as I had on my AT. I had loaded all my old familiar software onto the MS-DOS partition of my Unix system, and I could happily work away in the DOS window of the Unix SunView environment with WordPerfect, BRIEF, Quattro, Turbo C, and all my favorite DOS utilities. But I was relying on the DOS window and the DOS software to do many of the tasks I could have done better and faster in Unix.

Gradually, I realized that trying to do everything in the MS-DOS window was a mistake. The only way to learn about Unix is to use it as much as possible. Looking back, I can see that I used the MS-DOS capabilities of my system as a crutch, so it took me longer than neces-

How to think of the New DigiCHANNEL PC/Xi Intelligent Multi-Channel Communications Board.

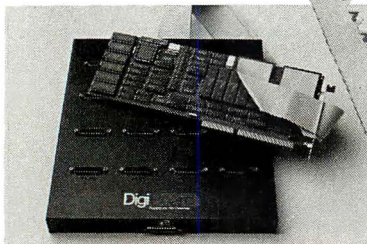

Think of the DigiCHANNEL PC/Xi as the cutting edge of flexibility. The new state-of-the-art in intelligent multi-channel communications boards.

A 12.5 MHz 80186 subsystem, featuring DigiBoard's Front End Processor real-time Operating System (FEP O/S), works in concert with whatever operating system you're using to ensure efficient I/O handling. Plug-in I/O Mate™ modules give you a



choice of 8 or 16 asynchronous ports to make it extremely flexible. You can specify from 128K to 512K of RAM, plus a variety of interfaces such as RS-232 and RS-422. There's even an optional synchronous channel.

So if your multi-user or multi-channel applications call for the last word in speed, configuration flexibility and programmability, the new DigiCHANNEL PC/Xi will put you at the cutting edge. Where you belong.

DigiBoard
Plugging you into tomorrow.

Call 1-800-344-4273. In Minnesota, (612) 922-8055.

**\$17
OFF**

INTRODUCTORY OFFER

**\$17
OFF**

Enjoy BYTE magazine's in-depth information on all the latest in personal computing each month at our special introductory rate!

Subscribe now and save \$17 off the newsstand price—12 issues for \$24.95 instead of \$42.00... and \$5.00 off the regular subscription rate of \$29.95. You'll also receive our special IBM PC issue as part of your subscription.

U.S.A. \$24.95 for 1 year Canada/Mexico \$26.95 U.S. for 1 year

Bill me

This is a renewal order.

Payment enclosed

Name _____

Charge to my

(Please Print)

MasterCard

VISA

Company _____

Account # _____

Address _____

Expires _____

City/State _____

Signature _____

Country _____ Code _____

For direct ordering, call toll free 1 800 257-9402 weekdays
9:00 AM-5:00 PM EST. In New Jersey, call 1 609 426-5535.

BYTE

Please allow 6-8 weeks for processing your subscription.

IBJ0824

**\$17
OFF**

LOWEST RATES

**\$17
OFF**

SPECIAL SAVINGS

SPECIAL SAVINGS



NO POSTAGE
NECESSARY
IF MAILED
IN THE
UNITED STATES

BUSINESS REPLY MAIL

FIRST CLASS MAIL PERMIT NO. 42 HIGHTSTOWN, NJ

POSTAGE WILL BE PAID BY ADDRESSEE

BYTE

Subscription Department
P.O. Box 558
Hightstown, N.J. 08520-9409

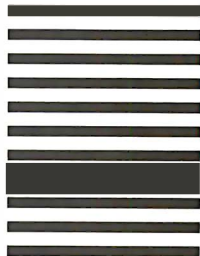

sary to become familiar with Unix. There are no shortcuts: To learn how to use software as powerful and complex as Unix, you have to practice.

Unfortunately, throughout this learning process—which is still going on, by the way—I didn't have that most important Unix resource: a local Unix guru. So, I had to look elsewhere. My first instinct turned out to be a good one: I read the introductory manuals that had come with my system. (You know how it is—when all else fails, read the documentation.) Sun Microsystems' introductory Unix manuals are excellent.

I also went back to the books I had looked over before I actually received my system. First, you have to separate the wheat from the chaff—and when it comes to books on Unix, there's a lot of chaff.

If you are responsible for taking care of a Unix system, *Unix System Administration* (Hayden Books, 1986) by David Fiedler and Bruce H. Hunter is excellent. It is clearly written and logically organized, and it has been an invaluable aid. Two other books that I found especially good for learning the basics are *The Unix Operating System* (second edi-

tion, John Wiley & Sons, 1988) by Kaare Christian and *Introducing the Unix System* (McGraw-Hill, 1983) by Henry McGilton and Rachel Morgan.

One thing you should keep in mind is that two major flavors or dialects of Unix exist in the computer world today: AT&T System V.3 and the University of California at Berkeley-derived BSD 4.2 (and BSD 4.3). These two versions share many of the same commands, but each has its own set of utilities and peculiarities not found in the other's repertoire.

Remember to choose a book that addresses either both versions of Unix or the version running on your machine. The three books I have mentioned are slanted toward System V but do address some of the differences between System V and BSD. The book by Christian is especially good in this respect.

A Tough Climb, but I Made It

This approach to learning Unix got me started in the right direction. But I made real progress only when I forced myself to choose Unix tools to do a particular task rather than using the familiar DOS tools—even though it meant doing things

a lot more slowly at first as I waded through the terse Unix commands manual. Basically, I had a tough climb up the initial slope of the Unix learning curve.

Another important resource that I used to get my questions answered was the Unix conference on BIX. On BIX, you can find real Unix gurus to answer your questions almost 24 hours a day; chances are, if you can't get your questions answered there, they won't be answered anywhere. The moderators and members of the Unix conference can give you prompt answers to most questions—sometimes you get more information than you bargained for. I still use BIX as an important resource.

It's been a little over a year since I made the switch from DOS to Unix, and the trials I've discussed occurred in the first few months. During that initiation period, my use of Unix versus DOS was about 20 to 80. Today, that ratio is more like 95 to 5.

I think the real breakthrough came for me after I had acquired a critical-mass knowledge of Unix commands and tools. One thing that helped me become more

continued

How to think of the New DigiCHANNEL PC/Xe Intelligent Multi-Channel Communications Board.

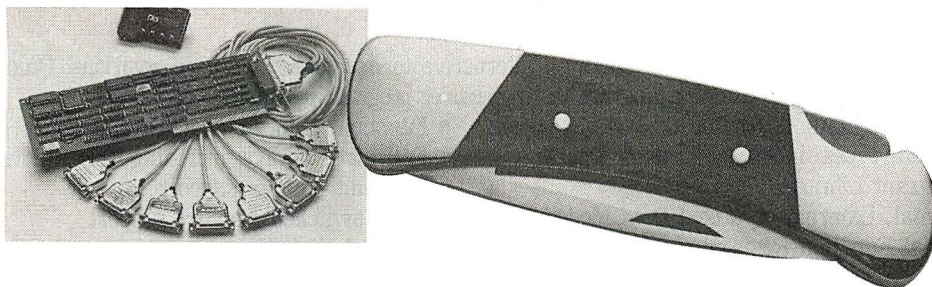

Think of the DigiCHANNEL PC/Xe as the cutting edge of economy. You asked for an intelligent multi-channel communications board to fit applications that don't need a host of "extra" features, and we listened.

An 8MHz 80186 processor gives you speed and power that basic boards can't match, yet its cost is surprisingly... well... *basic*. You can choose between 4 or 8 asynchronous channels, and you'll find that its

64K of RAM is plenty for such straight forward multi-user and multi-channel applications as data collection and office automation.

Best of all, the DigiCHANNEL PC/Xe is engineered and built to the same impressive standards as our DigiCHANNEL PC/Xi. So, no matter how simple or complex your system, you can trust us to get you up and running. And keep you there.

DigiBoard
Plugging you into tomorrow.

Call 1-800-344-4273. In Minnesota, (612) 922-8055.

fluent in Unix was realizing that conventions, such as the syntax of command-line arguments, regular expressions, the use of single and double quotes, and wild cards, are used consistently throughout virtually all Unix commands.

Once you learn how to use `sed`, for instance, you can transfer that knowledge to the use of `grep`, the line editor `ex`, or even that most versatile of Unix commands, `find`. With this background, I could appreciate how the Unix and SunView environments work as a whole.

I now have enough experience that I actually think first of using the best and most efficient Unix tool, rather than searching around for a DOS program that might do almost the same task but do it more slowly. Today, I use the Sun's MS-DOS window almost exclusively for transferring text and data files from DOS to Unix and back again, because I still use my 80286 DOS system at home for much of my work. I rarely run DOS software on the Sun.

20/20 Hindsight

My decision was the right one. The Unix software programs I needed for data

analysis and display run well on my workstation. I can do all my programming and data management tasks more quickly and effectively in the Unix environment. And new, DOS-type software, such as WordPerfect, is becoming available for Unix machines, which helps make Unix more friendly. I have the best of both worlds.

If I faced the same decision today, I would still choose a *real* Unix workstation like a Sun over the new high-speed 80386 DOS machines available now. First, I am a complete convert to being able to do true multitasking in a windowing environment, a Unix capability that is especially easy to use in SunView. Second, I must be able to use high-resolution color graphics with large programs that process large data sets (i.e., a computer with virtual memory) to carry out my research.

If I still had to keep one foot in the MS-DOS world, I'd choose a hybrid DOS/Unix computer like the new Sun386i workstation rather than a Sun-3 or Sun-4 workstation with added MS-DOS compatibility, as I did a year ago. Such machines do a better job of DOS emulation

than the 68020 or SPARC machines do (see "The Sun386i," December 1988 BYTE, and "Sun's Newest Workstation: the Sun386i" by Tom Thompson, July 1988 BYTE). However, for compatibility with the bulk of Unix software available for Sun computers, a Sun-3 or Sun-4 is the better choice.

In addition, the version of SunOS 4.0 that runs on the Sun386i has a friendlier window-based operating-system shell—for Unix, that is—than the versions of SunOS 4.0 and SunView that run on the Sun-3 and Sun-4 systems, so the Sun386i is easier at the start. Finally, while waiting for my new Unix workstation to arrive, I would definitely use software like the MKS Toolkit to help acquaint me with Unix while I was still working in my comfortable MS-DOS environment. ■

John Unger is a geophysicist for the U.S. government and lives in Hamilton, Virginia. He writes graphics software and uses computers to study the earth's crust. He can be reached on Usenet as "sun1.gd.usgs.gov!junger," or as "junger" on BIX, where he moderates the sun conference.

For Quicker Program Development the 8051 C Compiler

The 2500 A.D. 8051 C Compiler offers an alternative to Assembly Language solutions. Quicker program development. Simpler program testing. Easier program maintenance.

- Full Kernighan & Ritchie C
- All data types, including Float & Double
- Reentrant Libraries
- Internal, External or Mixed Data Modes
- Special Function Register support
- In-line Assembly Language
- Listings reflect actual linked addresses
- Function prototyping ANSI extensions
- Full math library, including Trig functions
- Interrupt handler support
- Bank switched memory support
- Internal bit field support
- Linked Assembly language
- Generates ROMable code

The 8051 C Compiler package includes the 2500 A.D. 8051 Macro Assembler, Linker, Librarian, Standard Library and Math Library and is priced at \$500.00 for MSDOS systems.

To order call Toll Free:

1 800 843-8144

In Colorado: 1 719 395-8683
Fax: 1 719 395-8206
Telex: 752659/AD

2500ADS SOFTWARE INC.

109 Brookdale Avenue
P.O. Box 480
Buena Vista, CO 81211

The Right Software for The Right Micro at The Right Price

NEW...FROM PERISCOPE

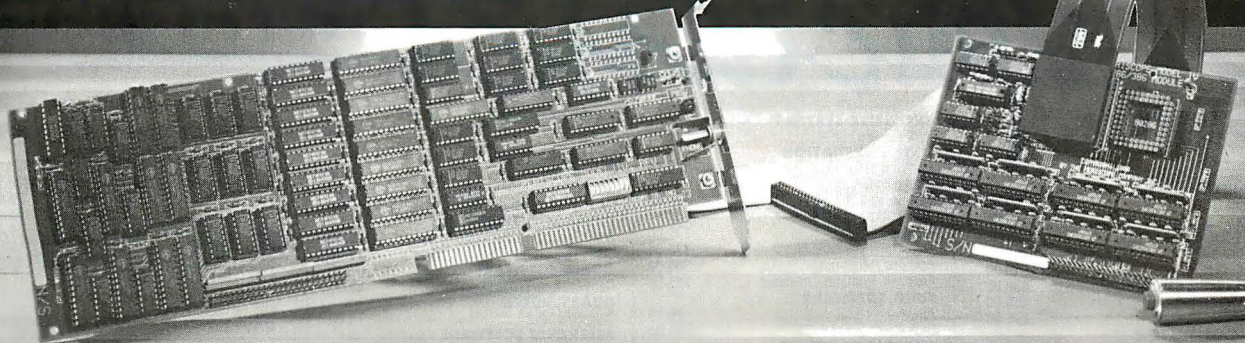

Real-Time Debugging for 386s and 286s

User Jeff Garbers, Crosstalk Communications' Director of Software Development, has been debugging with Periscope® Model IV and says, "The hardware really makes Periscope shine, especially when you've got timing-related problems. I can now track down changing pointers and altered buffers on my 386. I've been using it to debug Crosstalk® Mk. 4 and there's just no better way to do it."

Periscope IV gives you the ability to debug time-sensitive programs, hardware-interrupt routines, and programs with intermittent errors. You can run your program at full speed while tracking down unwanted memory overwrites. You can use the information captured in Periscope IV's real-time trace buffer to see EXACTLY what the system is doing, and to improve its performance.

Periscope manual, disk, quick-reference card, and 512K Plus board that provides write-protected RAM for Periscope Models I, III, and IV.

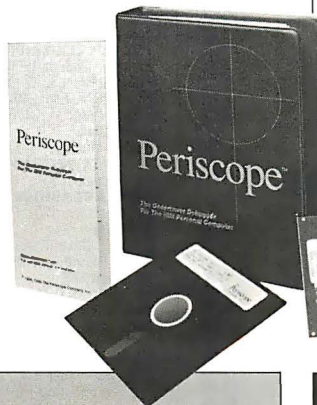

A New Generation of Hardware-Assisted Debugging

Compatible with virtually any 286 or 386 with an AT-style bus, Periscope IV works on machines running up to 25MHz with any number of wait states. Because it gets information directly from the CPU, instead of from the system bus, Model IV is not sensitive to bus compatibility issues.

Periscope IV collects CPU information in its hardware trace buffer while the CPU runs at full speed. Whether you tell Periscope IV to capture just selected information or to capture everything, you can use its powerful trace buffer commands to search for and display the execution history the way you need to see it. And you can use the CPU cycle count information to get the last bit of performance out of your code.

With Periscope IV you can set hardware breakpoints on memory accesses (within the first 16MB), I/O ports, and data. You can also set breakpoints on the occurrence of specific sequences of events, such as "watch for the routine FOO to begin executing, then while it is, watch for the variable BAR to be written." This capability, called sequential triggering, enables you to define complex conditions, then stop your program and examine what has happened when these conditions occur.

If you're developing a large application that needs all of the lower 640K, you can use the optional Plus board to keep Periscope totally out of normal DOS memory. The Plus board requires the use of a second slot.

The Periscope IV software is an extension of the software that comes with all models of Periscope. So, along with Periscope IV's powerful hardware, you get a full-function software debugger with source and symbol support for most popular PC compilers and linkers, Microsoft® Windows support, PLINK overlay support, dual monitor support, support for debugging device drivers and TSRs as well as regular programs, DOS independence, crash recovery, ease-of-use, and much more.

Prices on Periscope range from \$145 for software-only Model II-X to \$2,995 for a 25MHz 386 hardware-assisted Model IV. Call 800/722-7006 for pricing details, free information, to talk about your debugging needs, or to order your Periscope.

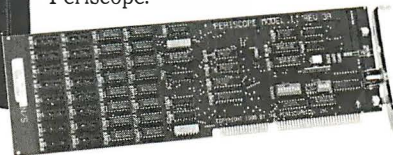

Order Your Periscope, Toll-Free, Today! 800-722-7006

MAJOR CREDIT CARDS AND QUALIFIED COMPANY PURCHASE ORDERS ACCEPTED



"No matter what your debugging needs, a single call to the Periscope Company has always sufficed..."

"Best of 1988" (Development Tools)
PC Magazine, January 17, 1989

The
Periscope
Company, Inc.

**1197 PEACHTREE ST.
PLAZA LEVEL
ATLANTA, GA 30361
404/875-8080
FAX 404/872-1973**

Compuclassics

WE WELCOME INTERNATIONAL AND CORPORATE ORDERS
FAX 1 818 705 4885

SOFTWARE

| | |
|-----------------------------------|----------|
| ALDUS | |
| Pagemaker 3.0..... | 499.00 |
| AMERICAN SMALL BUSINESS | |
| Design Cad..... | 159.00 |
| Design Cad 3D..... | 159.00 |
| ASHTON TATE | |
| Multimate II..... | 295.00 |
| Dbase IVs..... | 519.00 |
| Dbase IV Developers Edition..... | 839.00 |
| Framework III..... | 455.00 |
| Master Graphics..... | 295.00 |
| ASK SAM SYSTEM | |
| Ask Sam..... | 175.00 |
| AUTODESK | |
| Autosketch..... | 55.00 |
| Autosketch Enhanced..... | 65.00 |
| BAN-CER BLUE | |
| Org Plus..... | 55.00 |
| BLAISE COMPUTING | |
| Turbo Power Tools Plus..... | 85.00 |
| Turbo Async Manager Plus..... | 119.00 |
| C Tools Plus..... | 85.00 |
| C Async Manager..... | 119.00 |
| BLOC DEVELOPMENT | |
| Formtool W/Greatest Hits..... | 59.00 |
| BORLAND | |
| Sprint..... | 129.00 |
| Sidekick Plus..... | 135.00 |
| Quattro..... | 165.00 |
| Reflex..... | 99.00 |
| Turbo Prolog..... | 99.00 |
| Turbo Basic..... | 69.00 |
| Turbo C 2.0..... | 99.00 |
| Paradox V 5.0..... | 479.00 |
| Turbo Pascal 5.0..... | 99.00 |
| Turbo Tutor..... | 49.00 |
| BOURBAKI | |
| 1 Dir Plus..... | 55.00 |
| BRIDGEWAY PUBLISHING | |
| Fasttrax..... | 35.00 |
| Menu Block..... | 62.00 |
| BRODERBUND | |
| Print Shop..... | 35.00 |
| Memory Mate..... | 45.00 |
| BUTTONWARE | |
| PC File +..... | 45.00 |
| PC File DB..... | 69.00 |
| CENTRAL POINT | |
| Copy II PC..... | 25.00 |
| Copy II PC Option Brd Dlx..... | 115.00 |
| PC Tools Deluxe..... | 39.00 |
| CHRONOS SOFTWARE | |
| Who What When..... | 119.00 |
| CHIPSOFT | |
| Turbo Tax..... | 49.00 |
| Turbo Tax State..... | 29.00 |
| Turbo Tax Professional..... | 229.00 |
| Turbo Tax Professional State..... | \$149.00 |
| CLARIS | |
| Nutshell Plus..... | 209.00 |
| COMPUTER ASSOCIATES | |
| Supercalc V..... | 319.00 |
| Superproject Expert..... | 445.00 |
| ACCPAC BPI..... | 259.00 |
| Silverado..... | 99.00 |
| CONCENTRIC DATA SYSTEMS | |
| R & R Relational Report..... | 109.00 |
| CORE INTERNATIONAL | |
| Corefast..... | 79.00 |
| DAC | |
| Easy Accounting 3.0..... | 59.00 |
| Easy Payroll 3.0..... | 59.00 |
| Bonus Pack 3.0..... | 119.00 |
| Lucid 3D..... | 62.00 |
| Lightning..... | 42.00 |
| DATASTORM | |
| Procomm Plus..... | 49.00 |
| DBFAST | |
| Dblast Compiler..... | 62.00 |
| DELFINA | |
| Perform..... | 155.00 |
| DIGITAL RESEARCH | |
| Gem Desktop..... | 32.00 |
| Gem Draw Plus..... | 175.00 |
| Gem 1st Word Plus..... | 119.00 |
| Presentation Team..... | 289.00 |
| Desktop Publisher..... | 175.00 |
| Gem Artline..... | 289.00 |
| DIGITALK | |
| Smalltalk V..... | 75.00 |
| Smalltalk V 286..... | 145.00 |
| DYNAMIC ASSOCIATES | |
| PC Anwhere III..... | 85.00 |

| | |
|---------------------------------------|--------|
| EXECUTIVE SYSTEMS | |
| X Tree Pro..... | 69.00 |
| FIFTH GENERATION | |
| Fastback Plus..... | 109.00 |
| FORMWORX | |
| Formworx w/Fill & File..... | 89.00 |
| FOX SOFTWARE | |
| Foxbase Plus..... | 205.00 |
| Foxgraph..... | 175.00 |
| Foxbase Multi-user..... | 309.00 |
| Foxbase Runtime Unlimited..... | 365.00 |
| FUNK SOFTWARE | |
| Always..... | 89.00 |
| Sideways..... | 45.00 |
| GENERIC SOFTWARE | |
| Cad Level 3 w/Dot Plot & Convert..... | 169.00 |
| Dot Plot..... | 27.00 |
| Auto Convert..... | 27.00 |
| Auto Dimension..... | 27.00 |
| 3D Solid Modeling/Rendering..... | 179.00 |
| GIBSON TECHNOLOGY | |
| Spinwrite..... | 52.00 |
| GOLDEN BOW | |
| V Feature Deluxe..... | 89.00 |
| V Cache..... | 45.00 |
| HAVENTREE | |
| Interactive Easy Flow..... | 129.00 |
| IBM | |
| Displaywrite IV..... | 299.00 |
| DOS 4.01..... | 125.00 |
| INTUIT | |
| Quicken..... | 35.00 |
| LASERGO | |
| Go Script..... | 169.00 |
| Go Script Plus..... | 299.00 |
| LATTICE | |
| Lattice C Compiler..... | 229.00 |
| LEADING EDGE | |
| Word Processor V1.5..... | 89.00 |
| LOTUS DEVELOPMENT | |
| All Products..... | CALL |
| MATHSOFT | |
| Mathcad 2.0..... | 215.00 |
| MECA | |
| Managing Your Money 5.0..... | 129.00 |
| MERIDIAN TECHNOLOGY | |
| Carbon Copy Plus..... | 115.00 |
| MICROGRAFX | |
| Designer..... | 449.00 |
| MICROLOGIC | |
| Tornado w/Library..... | 79.00 |
| Tornado..... | 59.00 |
| MICROLYTICS | |
| Gofer..... | 45.00 |
| MICROPRO | |
| Wordstar Professional 5.0..... | 205.00 |
| Wordstar 2000 Plus..... | 269.00 |
| MICROMIM | |
| Rbase for Dos..... | 489.00 |
| MICROSOFT | |
| Quick C..... | 69.00 |
| Word..... | 235.00 |
| Quickbasic..... | 69.00 |
| C Compiler..... | 309.00 |
| Fortran Compiler..... | 309.00 |
| Macro Assembler..... | 105.00 |
| Learning DOS..... | 39.00 |
| Flight Simulator..... | 39.00 |
| Excel..... | 269.00 |
| Windows 386..... | 105.00 |
| Window 286..... | 69.00 |
| MICROSTUF | |
| Crosstalk XVI..... | 99.00 |
| Crosstalk Mark 4..... | 125.00 |
| MULTISOFT | |
| Super PC Kwik..... | 69.00 |
| NANTUCKET | |
| Clipper..... | 449.00 |
| NEW ENGLAND SOFTWARE | |
| Graph-In-The-Box..... | 75.00 |
| NORTH EDGE SOFTWARE | |
| Timeslips III..... | 115.00 |
| PAPERBACK SOFTWARE | |
| VP Planner..... | 55.00 |
| VP Planner Plus..... | 129.00 |
| PATTON & PATTON | |
| Flowcharting II Plus..... | 145.00 |
| PAUL MACE | |
| Mace Utilities..... | 55.00 |
| Mace Gold..... | 79.00 |
| PEACHTREE | |
| Complete Accounting II..... | 155.00 |
| Complete Accounting w/Data Query..... | 235.00 |
| PERSOFT | |
| Ize..... | 229.00 |

| | |
|--------------------------------------|--------|
| Smarterm 240..... | 179.00 |
| Referee..... | 39.00 |
| PETER NORTON | |
| Norton Utilities..... | 55.00 |
| Norton Utilities Advanced..... | 79.00 |
| Norton Commander..... | 49.00 |
| PRIME SOLUTIONS | |
| Disk Technician Advanced..... | 119.00 |
| Disk Technician Plus..... | 79.00 |
| QUAID SOFTWARE | |
| Copywrite w/Zerodisk..... | 55.00 |
| QUARTERDECK | |
| Desqview 2.2..... | 75.00 |
| REFERENCE SOFTWARE | |
| Grammatik III..... | 55.00 |
| RIGHTSOFT | |
| Rightwriter..... | 55.00 |
| SAMNA | |
| Ami..... | 99.00 |
| SANTA CRUZ OPERATION | |
| Xenix 286 Operating Sys..... | 405.00 |
| Xenix 286 Development Sys..... | 405.00 |
| Xenix 386 Operating Sys..... | 475.00 |
| Xenix 386 Development Sys..... | 539.00 |
| SCITOR | |
| Project Scheduler Network 4.0..... | 439.00 |
| SIMON & SCHUSTER | |
| New World Writer II..... | 99.00 |
| Typing Tutor IV..... | 32.00 |
| SOFTCLONE | |
| Mirror III..... | 55.00 |
| SOFTLOGIC SOLUTIONS | |
| Disk Optimizer..... | 42.00 |
| Cubit..... | 42.00 |
| Double DOS..... | 42.00 |
| @ Liberty..... | 172.00 |
| SOFTWARE MASTER | |
| Flash 6..... | 49.00 |
| SOFTWARE PUBLISHING | |
| PFS First Publisher..... | 79.00 |
| Professional Write..... | 125.00 |
| Professional File..... | 175.00 |
| PFS First Choice..... | 99.00 |
| Harvard Project III..... | 399.00 |
| Harvard Graphics..... | 309.00 |
| STORAGE DIMENSIONS | |
| Speedstor..... | 32.00 |
| SYMANTEC | |
| Timeline V3..... | 385.00 |
| Q & A..... | 229.00 |
| Grandview..... | 189.00 |
| Cambridge Spreadsheet Analyst..... | 99.00 |
| TRANSEC SYSTEMS | |
| Masterkey Unlock..... | 92.00 |
| dAnalyst..... | 199.00 |
| TRAVELING SOFTWARE | |
| Laplink Plus..... | 85.00 |
| UNISON WORLD | |
| Printmaster Plus..... | 32.00 |
| Art Gallery I & II & III (Each)..... | 19.00 |
| Newsmaster II..... | 55.00 |
| WISEWARE | |
| Prime Time..... | 65.00 |
| WORD PERFECT CORPORATION | |
| Word Perfect 5.0..... | 245.00 |
| Word Perfect Network Server..... | 355.00 |
| Word Perfect Network Add-On..... | 79.00 |
| Plan Perfect..... | 205.00 |
| Data Perfect..... | 309.00 |
| Word Perfect Executive..... | 129.00 |
| Word Perfect Library..... | 69.00 |
| Word Perfect Office..... | 259.00 |
| WORD TECH | |
| DBXL Diamond..... | 119.00 |
| Quicksilver Diamond..... | 349.00 |
| XEROX | |
| Ventura Publisher 2.0..... | 469.00 |
| HARDWARE | |
| ARRAY TECHNOLOGIES (ATI) | |
| VGA Wonder..... | 345.00 |
| EGAWonder 800..... | 249.00 |
| AST RESEARCH | |
| Six Pack Plus 384K..... | 309.00 |
| Rampage AT 512K..... | 439.00 |
| Rampage Plus 512K..... | 549.00 |
| AST 5251/11 Enhanced..... | 595.00 |
| ATD ZUCKER | |
| Monographics Short Card..... | 79.00 |
| Memory Expansion 384K..... | 219.00 |
| Modular I/O Bare P/S/Clock..... | 75.00 |
| Clock Board Standalone..... | 42.00 |
| CITIZEN | |
| 1200..... | 159.00 |

| | |
|--------------------------------------|---------|
| MSP 40..... | 349.00 |
| MSP 50..... | 445.00 |
| EVEREX | |
| EV 1800 8MHZ AT System..... | 969.00 |
| EV 1800 10MHZ AT 0 Wait..... | 1179.00 |
| Evercom II 1200 Modem..... | 75.00 |
| Evercom III 2400 Int Modem..... | 155.00 |
| Magic I/O For AT..... | 59.00 |
| RAM 3000 EMS Expansion..... | 99.00 |
| STEP 386 Computers..... | CALL |
| FIFTH GENERATION | |
| Logical Connection 256K..... | 519.00 |
| Logical Connection 512..... | 595.00 |
| HAYES | |
| Smartmodem 2400..... | 465.00 |
| Smartmodem 2400B W/Software..... | 425.00 |
| HERCULES | |
| Hercules Monochrome Plus..... | 199.00 |
| INTEL | |
| Above Board Plus w/512K..... | 435.00 |
| 8087-3 (5MHZ)..... | 105.00 |
| 8087-2 (8 MHZ)..... | 145.00 |
| 80287 (6 MHZ)..... | 159.00 |
| 80287 (8 MHZ)..... | 235.00 |
| 80287 (10 MHZ)..... | 269.00 |
| Inboard 386 PC w/1 Meg..... | 849.00 |
| 80387 (16MHz)..... | 389.00 |
| INTERNATIONAL BATTERY | |
| AT Replacement Battery..... | 17.50 |
| AST Six Pack Battery..... | 3.50 |
| KENSINGTON | |
| Masterpiece..... | 99.00 |
| Masterpiece Plus..... | 109.00 |
| Masterpiece Remote..... | 119.00 |
| LOGITECH | |
| Logimouse C7..... | 75.00 |
| Logimouse Hi Rez (NEW)..... | 89.00 |
| Logimouse C7 + Paintbrush..... | 105.00 |
| Logimouse W/Cad/Paint..... | 125.00 |
| Publisher Mouse..... | 125.00 |
| Scanman..... | 199.00 |
| Clear Case..... | 95.00 |
| MICROSOFT | |
| Mouse W/Paintbrush..... | 109.00 |
| Mouse W/Windows..... | 145.00 |
| MICROSWEEP | |
| Fast Trap Serial..... | 105.00 |
| Fast Trap Bus..... | 115.00 |
| MOUSE SYSTEMS | |
| PC Mouse Plus..... | 99.00 |
| NEC HOME ELECTRONICS | |
| Multisync II..... | 579.00 |
| ORCHID | |
| Pro Designer..... | 319.00 |
| Pro Designer Plus..... | 429.00 |
| PANASONIC | |
| KX-P10911..... | 199.00 |
| KX-P1595..... | 499.00 |
| KX-P1524..... | 619.00 |
| KX-10921..... | 349.00 |
| PARADISE | |
| Autoswitch 480..... | 219.00 |
| VGA Plus..... | 289.00 |
| VGA Professional..... | 529.00 |
| PLUS DEVELOPMENT | |
| Hardcard 20 MB..... | 459.00 |
| Hardcard 40 MB..... | 619.00 |
| POLAROID | |
| Polaroid Palette..... | 1499.00 |
| Polaroid Palette Plus..... | 2399.00 |
| PRACTICAL PERIPHERALS | |
| Practical Modem 1200 Internal..... | 69.00 |
| Practical Modem 1200 SA..... | 85.00 |
| Practical Modem 2400 INT..... | 165.00 |
| Practical Modem 2400 SA..... | 189.00 |
| SAMSUNG | |
| Amber Monitor..... | 95.00 |
| SEAGATE TECHNOLOGY | |
| All Products..... | CALL |
| SUMMAGRAPHICS | |
| Summasketch 1201 Plus..... | 389.00 |
| SYSGEN | |
| Ext 51/4" Drive (Specify Model)..... | 289.00 |
| Bridge File for Ext. Drive..... | 49.00 |
| TOUCHBASE | |
| Worldport 2400 Modem..... | 269.00 |
| Worldport 1200 Modem..... | 159.00 |
| TOSHIBA | |
| T 1000 Laptop..... | 875.00 |
| T 3100-20 Laptop..... | 3415.00 |
| P321 SL Printer..... | 549.00 |

ADVANTAGES

- We welcome corporate accounts
- Immediate replacement of defective goods.
- Immediate shipment on purchase orders from qualified government institutions (schools and universities included)

- No hidden charges.
- Bulk discounts

TERMS:

All prices are subject to change without notice. We do not guarantee compatibility. No surcharge for VISA or MasterCard. 2% surcharge American Express. No returns without RA#.

Short shipments must be notified within 48 hours. \$3.50 C.O.D. charge. Shipping \$5.00 minimum per item, less on bulk orders. (\$9.00 Blue Label.) (Higher for some software or hardware items.)

Call for prices for any software item not included in this price list.
 Order desk open 7 a.m. to 5 p.m. Monday-Friday (PST)
 10 a.m. to 2 p.m. Saturday (PST)
P.O. BOX 1588
 6934 Canby St., Suite #109-110
 Reseda, CA 91335

WE WELCOME INTERNATIONAL ORDERS

1 818 705-1895 US

1 800 231-6603 CA

1 800 328-4473 US

The Unix Connection

Usenet, UUCP, and NetNews give Unix worldwide communications power

Ben Smith

Unix has always implied connectivity, and UUCP (Unix-to-Unix copy) is the collection of programs that traditionally provides it. While all Unix licenses include the UUCP tools, many small systems never take advantage of them, nor of the worldwide network of computers that the tools connect. Many Unix E-mail users have no idea that they are using UUCP when they send E-mail to users at other sites. The beauty of it is that they don't have to know.

NetNews is Unix's BBS. It is the largest electronic BBS in the world, and, like many Unix operating-system utility extensions, its programs are in the public domain. However, unlike many other public domain programs, NetNews programs are usually created and maintained by professional programming teams.

The common element between UUCP and NetNews is the network, Usenet, so I'll begin there.

A Distributed Network

Although it's common to have your Unix machine as part of a small network of machines, perhaps within a university

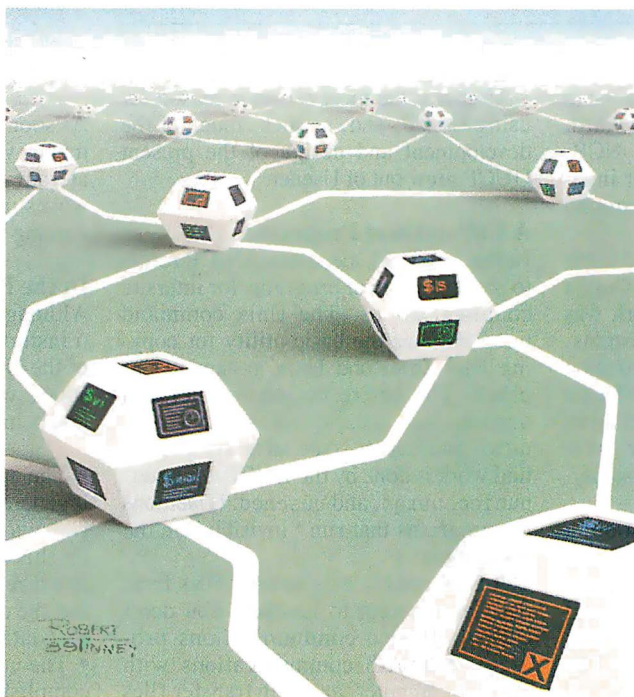

system or a company, few people want to pass up the opportunity to connect to "the net," or Usenet.

Although Usenet is an informal organization, more often than not controlled by de facto standards and traditions, it comprises the largest worldwide network of computers. Thousands of minicomputers, mainframes, and now even high-end microcomputers connect an estimated 1

million users. Rather than being configured as a central site with which all remote sites communicate (the configuration of BIX and CompuServe), Usenet is a distributed network.

Sites designated as *backbone* sites have well-defined responsibilities of collecting and forwarding messages to other regions (see figure 1). *Branch* sites have the less-defined responsibilities of passing information to other branch sites and to *leaf* sites. Leaf sites need only be polite and not burden their *feeds* with frivolous news and requests.

In 1979, Tom Truscott and James Ellis wrote a set of Unix shell scripts (using the more primitive operations of UUCP) to facilitate moving local news files between Duke University and the University of North Carolina. Steve Daniel, with the help of Truscott, rewrote the routines in C. Their work was presented as NetNews Release A at the 1980 USE-NIX conference.

As with many Unix enhancements, programmers at the University of California at Berkeley developed a version with many features that appealed to the

continued

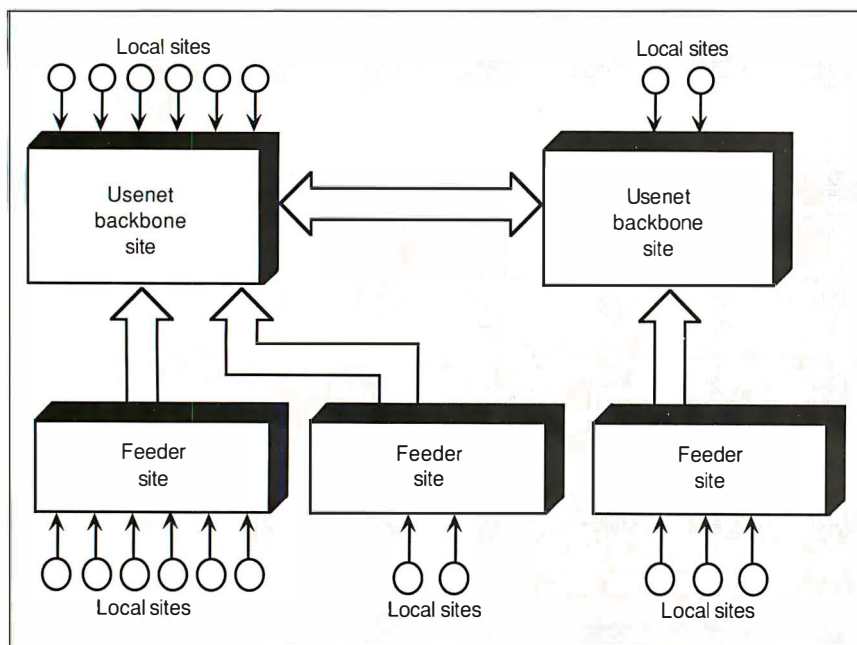

Figure 1: The relationship between the local site and the backbone site. Mail-routing functions exist between backbone-site machines. By consulting a map of all the intermediate sites and most of the leaf sites, UUCP can figure out a path for your message.

growing numbers of Unix users. Since then, NetNews and Usenet have been adopted by Bell Labs, Hewlett-Packard, Digital Equipment Corp., IBM, NCR, Motorola, Unisys, and many other institutions of industry and education around the world.

As the number of Unix sites and users grew, so did the traffic on Usenet. Until a few years ago, joining the network was difficult for users of new Unix systems, because there was no real organization through which to apply. You had to find a site that would let you get a feed from them. Since resources are never free, many people are reluctant to let just anyone tie in through their machine.

In 1987, the USENIX organization, a Unix users group, funded an experimental public site, UUNET, organized by Rick Adams. New Unix systems could subscribe to network service from this single site for a fixed monthly fee. The experiment generated enough revenue and interest that UUNET has become a real entity, owning its own equipment and paying its own bills.

The new UUNET machine is a Sequent S81 with four processors and almost 2 gigabytes of disk space. Because of the computer's modularity of parallel processing, it can be expanded to 30 processors and virtually unlimited disk space. The machine contains the sources for many of today's Unix standards, in-

cluding TEX and X Windows.

Usenet is the most common reason for using UUCP, and, as such, much of the development and design of the present UUCP grew out of Usenet.

A Collection of Programs

In the lingo of Unix users, UUCP refers to the collection of programs for intersite communications. The Unix command `uucp` initiates the basic utility for copying files from one Unix system to another. The entire collection includes `uucico`, `uux`, `uuxqt`, `uustat`, `uuclean`, `uuto`, and `uupick` (see table 1). The actual work is done by the UUCP daemons: `uucico`, `uuxqt`, and `uusched`. (Daemons are programs that run "invisibly" in the background.)

It is incredibly easy to copy files from one Unix system to another. You don't have to enter a communications program, establish communications with another computer, and then transfer files using `upload` or `send-file` commands. All you have to do is enter `uucp source-files destination`. The only real difference between using this utility and copying files from one subdirectory to another within the same system is that the source file or the destination can contain site names or addresses.

For example, if I want to copy the source for the Notesfile system (the filename is `Notes.tar.Z`) from the UUNET

machine in Virginia to the Notes subdirectory on my machine in New Hampshire, I would issue the following command:

```
uucp uunet! /usr/spool/ftp/news/
Notes.tar.Z /usr/users/ben/Notes
```

The only complexity in this command is the directory path to the file. The `!` is appended to site names to distinguish them from subdirectory names. (Unix uses the forward slash `/` to delimit subdirectory names where MS-DOS uses the backslash `[\]`.)

You can abbreviate directory paths by using the tilde (`~`) to represent the home directory of a log-in. The home directory for `uucp` is the public file-exchange area; in this case, `/usr/spool/ftp`. More often than not, however, it is `/usr/spool/uucppublic`. My home directory (log-in `ben`) is `/usr/users/ben`; it might be `/usr/ben` on another machine. The use of the tilde abbreviation resolves these site-specific differences. The simplified command with abbreviated pathnames then becomes

```
uucp uunet! ~uucp/news/Notes.tar.Z
~/Notes
```

As soon as you have issued the `uucp` command, you can continue with other work at your terminal or workstation. UUCP works in the background, without interrupting you or slowing you down.

In the Background

Although generating the request for a file transfer is simple, the actual operations of the UUCP daemons are not. Figure 2 shows what happens in the background and behind the scenes.

- The `uucp` utility is a *spooling* program. It generates a list of work to be done with files and prepares the files for processing (in this case, it makes a copy of the files in a directory set aside for this purpose). But the daemon `uucico` performs the actual data transfer.
- The `uucp` utility invokes `uucico` to accomplish the data transfer. The `uucico` daemon places the call to the remote system (usually through another program, `dial`), starts the companion `uucico` on the remote site, reaches an agreement with it on a data transfer protocol, and begins sending control files and the data files.
- The `uucico` daemon on the remote machine has assumed the slave role. The originating site—the master—controls it.
- After the originating site has sent all

its requests, uucico reverses the roles of master and slave. It gives the remote site a chance to send anything it might have spooled. Once the transfers are complete, both machines agree to break the connection.

- As a last task, each uucico invokes uuxqt to move the files to the requested subdirectory and to process any other tasks that were requested.

- Throughout the whole process, uucico updates logs of its activities so you can see the progress of your requests (by using uustat), and the system administrator can keep tabs on communication inefficiencies and security threats from other systems.

Unix Mail

When you send mail to someone on another system, you use mail (or mailx), just as if that person were on your local system. In other words, the user interface is the same whether you send mail to someone local, on your LAN, or across the world. The difference lies in how you address the mail. You prefix the recipient's name with his or her address. The address consists of a list of machines through which to route the mail, with each site name appended with a bang (!).

If I wanted to send mail to George Bond on the bixpb computer, I would issue the command mail bixpb!gbond (or uunet!bixpb!gbond, if my local computer connects to bixpb through uunet). I would compose the mail message in the usual way. George would find it on his machine just as if someone local had sent it to him. He could reply to it

continued

Table 1: The Unix utility commands and daemons.

| Name | Category | Description |
|----------|----------|---|
| cron | daemon | Processes repeated events on Unix systems. It uses tables created by crontab. |
| crontab | command | Schedules repetitive events on Unix systems. |
| mail | command | A program for sending, reading, and managing E-mail. |
| mailx | command | A more complex version of the E-mail program. |
| postnews | command | Posts new articles to NetNews. |
| readnews | command | Simple, line-oriented method of reading messages from NetNews. |
| rmail | daemon | Delivers mail to a user on a remote site. |
| rn | command | A flexible and complex program for reading and managing NetNews messages. You can create macros and totally automate your news with this program. |
| rnews | daemon | Processes incoming NetNews articles. |
| uucico | daemon | Processes requests for file transfers and remote commands, both on the originating site and on the destination site. |
| uuclean | command | Cleans up and deletes unwanted UUCP requests. |
| uuep | command | Spools requests for copying files to and from other systems. |
| uupick | command | Requests a remote system to send a file from the public spooling area of a remote site. |
| uusched | daemon | Schedules UUCP connections. |
| uusend | command | Requests a file to be sent out through a series of remote sites. |
| uustat | command | Views the status of and deletes UUCP requests. |
| uuto | command | Requests a file to be sent to the public spooling area on a remote site. |
| uux | command | Spools requests for commands to be run on remote sites. |
| uuxqt | daemon | Processes remote requests for programs to be executed locally. |
| vnews | command | A slightly more complex, screen-oriented program for reading messages from NetNews. |

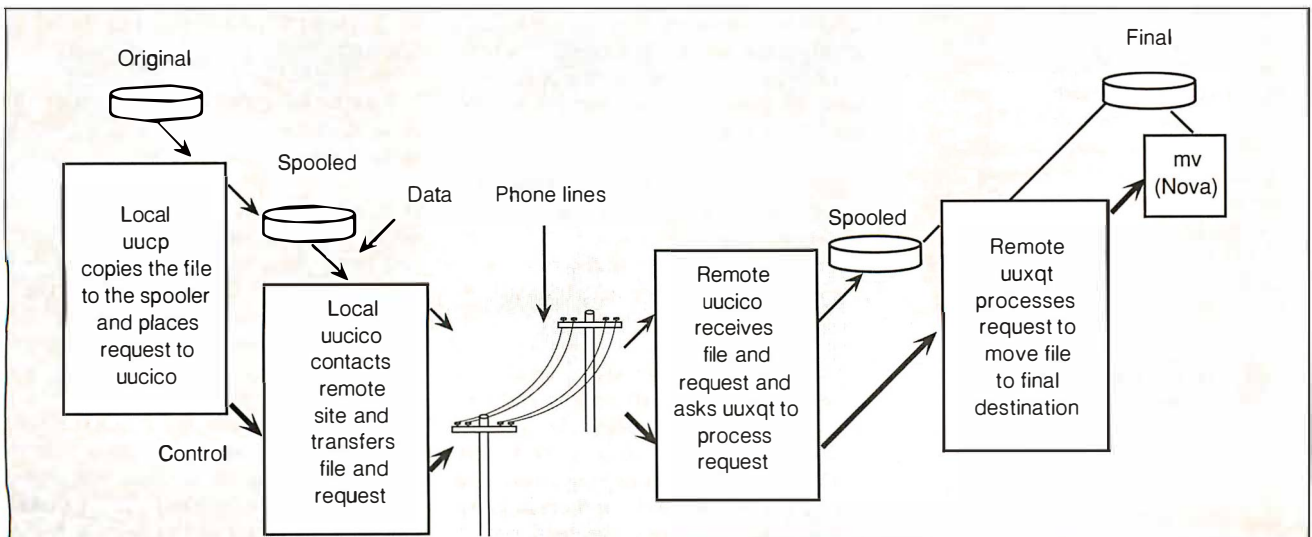

Figure 2: The UUCP background operations for copying a file. Although it is simple to generate the request for a file transfer, the actual operations of the UUCP daemons are more complex.

Mixing REAL TIME With REAL UNIX[®] Is Not Magic...

It Is Technology.

VenturCom's real time UNIX product family has the only real time kernel for standard hardware platforms which is AT&T's UNIX System V. Not a simple UNIX clone. Not just UNIX on top of a real time executive.

Real UNIX provides designers with SVID and POSIX standards, RFS and NFS, X-windows, Streams, complete development tools, multiple DOS under UNIX tasks. And early access to future technologies.

Real time adds performance and functionality to UNIX with preemptive and biased scheduling, contiguous file system, average interrupt latency of 50 μ s, bounded context switches, memory locking, asynchronous I/O, and much more.

Ask us about VENIX[™] for 80286/80386 PCs and Single Board Computers; RTX[™] for other UNIX versions, such as Interactive System's 386/ix[™], and small, diskless, and ROMable UNIX kernels. Find out why Foxboro, Toshiba, GE, and many others are using VenturCom's real time UNIX products.



Real Time/Real Unix

215 First Street
Cambridge, MA 02142
(617) 661-1230

Nippon VenturCom, Inc.
Tokyo 102 Japan 03-234-9381

UNIX is a registered trademark of AT&T
386/ix is a trademark of Interactive Systems Corp.
VENIX, RTX are trademarks of VenturCom, Inc.

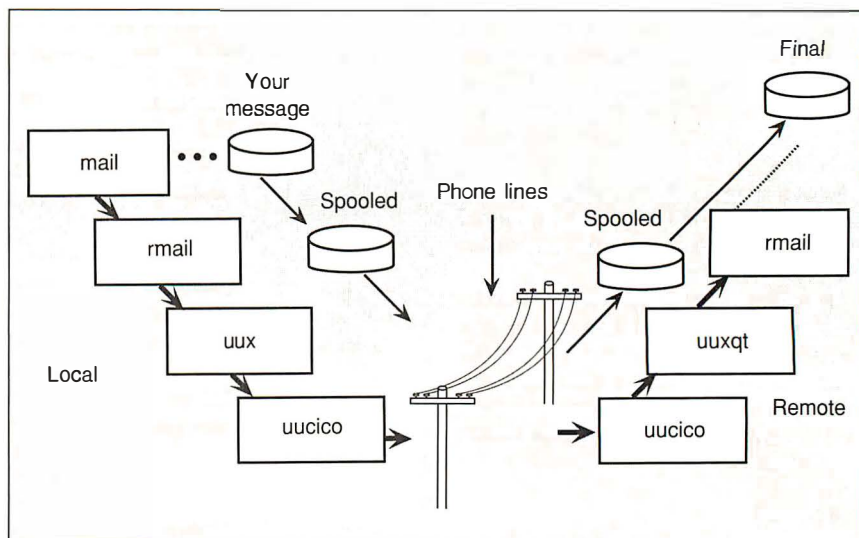

Figure 3: How mail is delivered to remote sites. UUCP recognizes when the mail recipient is on another system. Instead of putting the mail-delivery request in the local mail spooler, UUCP passes it to uux to deliver at the remote site with rmail.

without worrying about where it came from, since the mail header has my address. His machine would send the response back in the same way my machine sent the original message. If there were any intermediate machines, the address string would include the machine names.

It's possible to contact anyone who has access to a machine that links to Usenet. There are direct links to ARPANET, the Center for Mathematic and Computer Science in Amsterdam, which acts as the common node between Usenet and the EUnet (the European Unix network), New Zealand, Bangkok, Seoul, Toronto, and hundreds of other sites around the world. Unix users often give their Usenet addresses whenever they give out their regular mail address and phone number.

Because of the complexity of Usenet, some of these addresses can become ridiculously long:

```
bixpb!uunet!111-winken!111-ncis!
helios.ee.lbl.gov!pasteur!
ucbvax!agate!bionet!
csd4.milw.wisc.edu!uxc!
uxc.cso.uiuc.edu!m.cs.uiuc.edu!
aguest.
```

This address was probably generated by a very inefficient mail-routing routine. The message would originate in New Hampshire, go to Virginia, work its way to California, go back to Wisconsin, and eventually end up on the appropriate machine. The sites that have long names broken by dots are LANs; each subname is a node on the LAN.

As with most tedious and error-prone

tasks that you encounter on Unix machines, there are quick and efficient ways to generate addresses. First, the UUCP system has aliases for long addresses. That is, you can address mail with a nickname; a table supplies the full address path and the real name.

Second, there are mail-routing functions on backbone-site machines. UUCP on these machines consults a map of all the intermediate sites and most of the leaf machines, and it can figure out a path for your message. All you supply is the path to the backbone site and the name of the destination machine. Thus, you can reduce the monstrous address above to

```
bixpb!uunet!m.cs.uiuc.edu!
aguest
```

If I communicated with this account more than once, I would create a nickname for it.

Behind the Scenes

What is happening with mail delivery "behind the scenes" is more complex (see figure 3). The mail program can recognize when the recipient of the mail is on another system. Instead of putting it in the local mail spooler, it passes the mail-delivery request to uux to deliver at the remote site with rmail, the remote mail utility. The uux utility executes programs at remote sites. Like uucp, you can use uux alone for specific tasks; however, it is restricted to commands in a UUCP control file at the remote site.

The uux utility passes the rest of the work, including the mail file and the

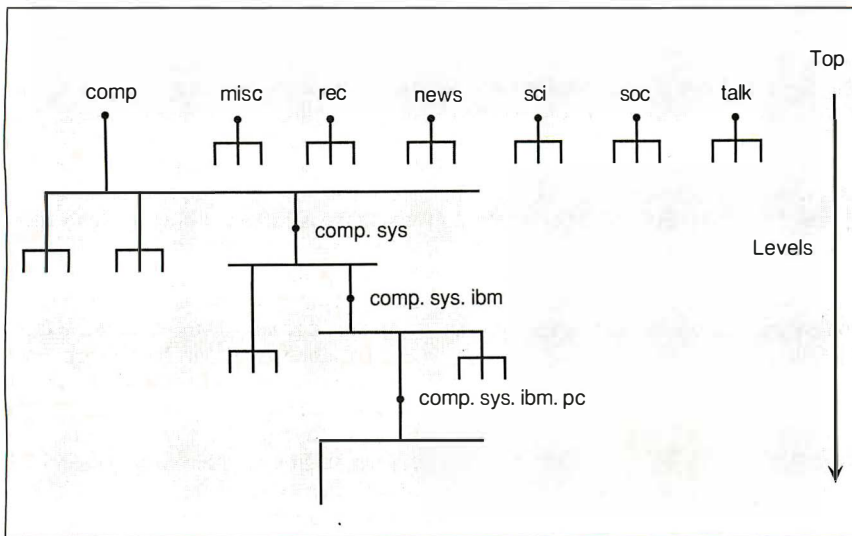

Figure 4: The hierarchical organization of newsgroups. Each major newsgroup has several sub-newsgroups, which in turn may have their own sub-newsgroups, and so on, sometimes to four levels. This organization makes it easier to find special newsgroups and provides the file structure for the actual messages.

rmail commands for its delivery, to uucico, which calls the remote system. The mail system maintains a mailbox for each user. The mail-administration program appends new mail messages to the file. When you read your mail, the mail program deletes those messages from your mailbox in the mail-spooler subdirectory. (You can save a copy in your home directory if you wish.)

Files and process requests are transmitted in both directions during each connection. Letting a remote site start a process on the local site can be a real threat to system security. In addition, uncontrolled communications over the phone system can be very costly.

Control and Scheduling

If a lot of local users send messages to remote systems, the local system will be dialing up other systems all day, and the phone bill will be astronomical. To keep communications as efficient as possible, several built-in controls to the UUCP utilities also affect the remote mail transfers and NetNews transfers.

Sites usually connect only a few times a day. (Direct connections and LANs are obvious exceptions.) Instead of having the mail system and other UUCP requests initiate the uucico daemon, cron (the system scheduling daemon) invokes uucico.

The cron program continuously runs in the background of Unix systems. It works like the timer clocks that turn your house lights on and off when you leave on vacation. Once a minute, cron checks

the crontab tables to see if there's any task that needs to be done.

It's customary to create a crontab table that invokes uucico for each remote site once or twice a day (or even once an hour if a faster turnaround is required). When two sites make a connection, data and request transfers are bi-directional. It doesn't matter which site initiates the call; therefore, it is of little value for your machine to call sites that are scheduled to call you.

Your machine may call some remote systems only once a day, perhaps at 1:00 a.m. when phone rates are the lowest. Although this slows down communication turnaround, it dramatically reduces operating costs.

Security

System security is more sophisticated for UUCP than for the typical user-log-in process. When you log onto a Unix system, it screens you only by checking your password with your user ID. Once you are onto the system, you are only restricted by your group ID. It's fairly simple to keep track of what you, as an individual, have done while on the system. But UUCP log-ins have the potential of giving thousands of users access to your system. Although access is vicarious, the danger is real.

Usually, UUCP accounts are limited to copying files to and from the UUCP spool directory, and they cannot access anything else. In addition, the UUCP can run only uucico, rmail, and rnews

continued

IEEE 488

Interfaces & Software

Hardware

IEEE interfaces for PC, AT, 386, PS/2, Macintosh, HP, SUN & DEC. Converters from IEEE to RS-232, RS-422, modem, Centronics, SCSI, digital I/O and analog I/O. IEEE extenders, expanders & buffers.

Software

IEEE device drivers for DOS, UNIX®, Macintosh & SUN. Drivers for Lotus 1-2-3 & Symphony. Macintosh IEEE desk accessory. PC menu-driven analysis.

Support

Free applications support. 30 day money-back guarantee. Two year warranty. IEEE seminars available.

Call for your FREE Technical Guide

Demo disks & application notes available



(216) 439-4091

Telex 6502820864 • Fax (216) 439-4093

IOtech, Inc. • 25971 Cannon Road • Cleveland, Ohio 44146
London (0734)861287 • Paris (1)34810178 • Milan (02)4120360
Brussels (02)3848062 • Linköping (0131)10140 • Helsinki (90)5215288
Munich (089) 710020 • Zurich (01)8219444 • Vienna (0222)253626
Gorinchem (01)83035333 • Oslo (02)649070 • Copenhagen (02)804200
Madrid (91)4027060 • Lisbon (01)41013420
Melbourne (03)5793622 • Toronto (416)6740444



Important

UNIX will catch on

Since end of 1988 you don't need star wiring for multi-terminal systems any more. Instead, all those terminals can be connected to a single twin-conductor telephone wire. Neither the terminals nor the computer need be prepared for the bus system - and it won't cost any more than the familiar cabling. This eliminates the main disadvantage of multi-terminal systems as compared with networks. Ask for "TerminalBus" information.

Terminals/printer up to 3/4 mile away

Electrically isolated line drivers let you set up terminals or printers at distant locations.

- # 22boost, Cenbronica, 1 pair, 1kV isol.
- # 84boost, RS232, 1 pair, 1kV isolated

Mains filters won't do it all

When computers mysteriously crash, or suffer from lightning discharges, the damage usually arrives along the data lines. Now, opto-isolators that will stand up to 50kV can help you: just interpose them between the computer and its peripherals.

- # 22boost, Cenbronica, 1kV
- # 66iso, RS422, 500V
- # 88iso, RS232, 1kV
- # 88iso50, RS232, 50kV

Portable Data Buffers

Instrument readings, drilling templates, programs - you can transport all kinds of data in a small, battery-powered buffer.

- # 22b032, Cenbronica, 32K
- # 22b128, Cenbronica, 128K
- # 88b032, RS232, 32K
- # 88b128, RS232, 128K

Computers up to 95% faster

Your computer is forced to run with the brakes on because standard printer and plotter buffers are far too small. A buffered data cable will accelerate your computer by up to 95%.

Parallel for PCs:

- # 221064, 64K
 - # 221256, 256K
 - # 2211024, 1024K
- RS232, individually selectable In/Out param.
- # 88128, 128K
 - # 88512, 512K



The ideal T-switch?

It's so small, it fits into a printer plug - and, naturally, needs no plug of its own. But it will automatically switch a printer between two computers. And it sells so well that just a few lines of advertising are sufficient.

- # 22imca2, 2 PCs to 1 printer

The comprehensive interface program

| | |
|--|--|
| 20mA Atari C64/128 Centr. IBMPC IEEE488 RS232 RS422 RS423 RS485 | 20mA Atari C64/128 Centr. IBMPC IEEE488 RS232 RS422 RS423 RS485 |
|--|--|

W&T
✓ o.k.

New catalogue

since Dec, 1st, 88

wiesemann & theis gmbh



THE INTERFACE PEOPLE

Winchenbachstr. 3-5

5600 Wuppertal 2

West-Germany

Telefon: (202) 50 50 77

Telefax: (202) 51 10 50

Telex: 859 1656 wwd

Austria: Basic 0222-950542 • Belgium: Brother 02-4674211, Info Uniers 03-2323247 • Denmark: Jatec 06-479139 • England: Meedmore 051-5212202 • France: Neol 88-623752 • Mexico: Syper Puebla 489236 • Netherlands: Cat&Korsch 010-4507696 • Switzerland: Weber 01-9302003 • Singapore: Overseas Trade 2726077 • Distributors wanted!

(restricted news posting). Some people allow remote UUCP log-ins to run who and 1c, but these utilities weaken security by providing information for system infiltrators to make logical guesses about passwords.

A more sophisticated version of UUCP is the HoneyDanBer UUCP, or BNU (basic networking utilities) UUCP. This version and others based on it have tables that provide much more finely grained control over access by other systems. For example, instead of having one set of re-

Many of us already suffer from severe information indigestion.

stricted commands for all remote systems, the BNU system provides different levels of access for each remote site. In addition, it can restrict what information local users request from remote sites.

In general, the UUCP files contain information about which remote systems are available and how UUCP logs onto them; which requests for file transfers are pending, in progress, and complete; which operations remote sites can start on the local site; and flags to lock ports that are in use. These control files contain sensitive material, and therefore only the system administrator is allowed to read them.

The largest amount of communication on Usenet is not E-mail, however; it's NetNews, Unix's electronic bulletin-board activity. NetNews is the biggest reason for control and the largest source of traffic.

NetNews

NetNews is not a news service along the lines of United Press International. It is the actual activity of the developers and users of high technology. The messages are not journalism; they are the source of journalism. This is active conferencing, like you would find on BIX.

Three commonly used programs exist to read and respond to the news: readnews, vnews, and rn. If you are new to reading news, use readnews. It's the simplest. However, if you need the power of macros and the flexibility to custom-

ize the system, you will want the flexibility of rn. All three programs let you respond to messages, reply to the author directly with E-mail, file messages, and save messages. They use lists in your home directory to keep track of what subjects you are interested in reading and which messages you have already read.

Messages are organized as separate articles within *newsgroups*. Newsgroups are organized in hierarchical structure with only a few at the top of the structure. Each major newsgroup has several sub-newsgroups. Each of these may have its own sub-newsgroups, and so on, sometimes to four levels of organization (see figure 4). For example, you can find the messages relating to bug fixes for BSD 4 Unix in *comp.bugs.4bsd.ucb-fixes*. This organization not only facilitates finding special newsgroups, it also provides the file structure for the actual messages.

In many ways, sending news is like sending mail, but instead of sending the message to an individual, you send it to a newsgroup. Reading the news can be a big task, not because it's more complicated than reading and replying to mail but because of the sheer volume of news on the system. You select which articles you want to read from the list of article headers. Discussions within a newsgroup are tied together by the subject in the article headers. You can follow an entire conversation within a newsgroup before going on to read another conversation within that same group.

Or you can mark a subject for rejection. For instance, if you are interested in Atari ST computers, you might join the newsgroup *comp.sys.atari.st*. If there were a conversation about MIDI programs and devices and you had no interest in them, you could automatically kill all new articles with the keywords *MIDI* and *music*. Similarly, you might be interested in data acquisition and analysis, and you could automatically save all articles with these keywords.

Unlike BIX, all news messages are copied onto the local machine. You and other local users peruse them without connecting to a remote machine. A NetNews message has a header that describes the E-mail address of its originator, which newsgroups the message belongs to, its subject matter, the date it was posted, and a unique message ID.

A Little More Complex

NetNews operations are far more involved than Unix mail operations. The basic data transfer is the same, using *uucico* and *uuxqt*. But managing the

news is more complex, from the time a message is posted to the time it is read by perhaps hundreds of thousands of users.

When you post a news message, it is immediately added to the news on your local machine. The news-posting program gives the message the next article number in that newsgroup. Everyone on your local machine can now read that item. Users have private files showing which articles they have read and which newsgroups they subscribe to. The news-reading programs take care of things from there—for the local users.

For the network, things are more complex. A site may send and receive news at the same time that several other sites do. This information exchange doesn't occur over a simple single-direction pipeline. If all the newly received messages are passed on to all the other sites, the same messages would be received and sent over and over, as many times as there are possible paths from one site to another.

The communications load would be beyond the limits of imagination. A network of just six sites can provide up to 64 possible paths, a network of 10 sites provides many millions of possible paths, and Usenet is composed of many thousands of nodes—how many possible paths would that be?

The problem of controlling news flow used to be solved by trading news the same way people trade baseball cards. Each site must end up with only one copy of every available message. The conversation between NetNews sites would go like this: "I have. You have? I don't have these, but you do. I have these that you

don't. I'll give you these, and you give me those." The key to the process is the unique message ID that is created for each message. It is composed of the site name and the value of the message counter at that site.

Today, other methods are used as well. For instance, if one of the connecting sites' names appears in the Path: field of the message header, you can assume that the site has already seen the message.

A full news feed can take up as much as 4 megabytes a day. No one has enough disk space to accumulate data at that rate for very long, so messages more than two weeks old are usually discarded. Their message IDs are kept to prevent reacceptance of any copies that might still be bouncing around the network. The communications load is further reduced by data-compression programs that are part of the news sharing and batching.

Information Overload

Computers and communications lines can handle this load, but can we? Are we doomed to information overload? Many of us already suffer from severe information indigestion. Using these "free" Unix communications and news utilities is very appealing, but the amount of information can be overwhelming.

Since the UUCP programs open our machines to oceans of new information, it's best to start with a little at a time. The most useful facility is the ability to send E-mail through Usenet. You may also need to send and receive documents with other Unix sites.

If you decide to become involved in NetNews, start by subscribing to just one newsgroup, such as "comp" or "rec." Learn to use the news-reading program of your choice. Don't let your appetite for the network's information exceed your capacity to digest it.

However, NetNews is as pure an example of "social networking" as you will find. It's great fun to meet and talk with others about your interests without having to join a club or a society. If you are doing research or are looking for help with some problem, an electronic BBS, such as NetNews or BIX, can provide answers in hours to questions that might otherwise take months or years to find answers to. ■

ACKNOWLEDGMENTS

Special thanks to Donnalyn Frey and Rick Adams of UUNET, and to the many members of Usenet who provided information about NetNews.

BIBLIOGRAPHY

- Fiedler, David, and Bruce Hunter. *UNIX System Administration*. Berkeley, CA: Hayden Books, 1986.
- O'Reilly, Tim, and Grace Todins. *Managing UUCP and Usenet*. Newton, MA: O'Reilly & Associates, 1988.
- The Waite Group. *Unix Communications*. Indianapolis, IN: Howard W. Sams & Co., 1987.

Ben Smith is a BYTE technical editor and a former Unix applications developer. He can be reached on Usenet as "uunet!bix-pb!bensmith" or on BIX as "bensmith."

80386 20MHz XENIX computer COMPLETE
with 40MB <28ms FH hard drive, 1.2MB floppy, 2 serial / 2 parallel ports,
high resolution monochrome monitor with adapter, 101 enhanced keyboard,
386 SCO XENIX and a TWO YEAR WARRANTY now only **2,995.**
Many hardware and software options available.



TRC TECHNOLOGY RESOURCE CENTER

In the US call **800/433-4904**
In California **213/937-8822**
In the United Kingdom **0800-89 1121**
FAX: 213/937-9034
TELEX: 159211426 TRC UT

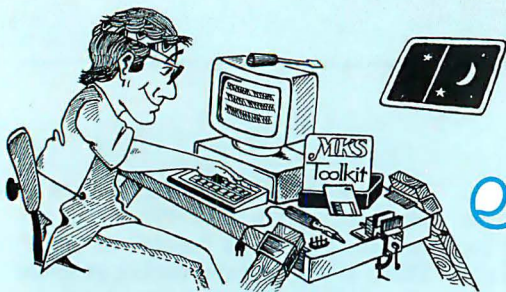

MKS Toolkit™

UNIX™ Tools on DOS or OS/2

Programming today means you must work within more than one environment. A diverse range of hardware is now a fact of life. With the MKS Toolkit, you can enjoy the best of DOS or OS/2 and UNIX environments. The MKS Toolkit offers both experts and novices the purest form of UNIX utilities that the DOS or OS/2 environment allows.

Reduce Keyboard Shock

With our proprietary code, the MKS Toolkit offers you more than 140 UNIX System V.3-compatible tools for DOS or OS/2. With the MKS Toolkit, your computer or clone becomes a comfortable environment for shells, string matching, editing, file manipulation, and more. Productivity increases because all the familiar commands are at your fingertips.

Site Licenses

The MKS Toolkit reflects its users' needs. Organizations such as AT&T, H-P, ITT, and NCR - all heavily committed to the UNIX system - use the MKS Toolkit to create a standard operating environment. Universities, including UCLA, use the MKS Toolkit to enrich personal research computing environments and double the bandwidth of their PC teaching labs. The National Institute of Standards and Technology fulfills diverse needs by using the MKS Toolkit as standard operating environment for experts and as a POSIX-conforming training tool for neophytes.

Interconnectivity

The MKS Toolkit provides two types of valuable interconnectivity. First, it interacts well on most standard PC and PS/2 networks. Combined with Novell Netware™, the most popular LAN for

PCs, the MKS Toolkit creates a UNIX time sharing system in DOS or OS/2 organizations. UNIX shops can now hook up all their PCs using PC-NFS™ and the MKS Toolkit, enabling you to use a PC as a UNIX workstation and off-load your mini or mainframe machine. The second level of interconnectivity is created by the MKS Toolkit's ability to recognize common UNIX file formats on DOS or OS/2 and to make DOS or OS/2 file formats available on UNIX systems.

POSIX-Conforming Tools

MKS is an active participant on the POSIX 1003 standards committee. This involvement reflects MKS' commitment to tracking the shells and utilities standard to the fullest extent possible under DOS or OS/2. Apart from multi-tasking and constraints on file names under DOS or OS/2, the MKS Toolkit follows the POSIX standard. MKS achieves this by building the underlying POSIX system on DOS or OS/2 before moving utilities.

Cost-effective Learning Tool

If your organization is committed to moving into the UNIX environment, then the MKS Toolkit is the perfect learning path. DOS or OS/2 users retain the familiar world of their PC keyboard and programs and move effortlessly to a UNIX environment on their desktop. Exposure to new commands and functionality now becomes an integral part of the novice's working day. UNIX solutions are easily available and the DOS or OS/2 world is but a keystroke away.

MKS Programming Platform

The MKS Toolkit is the vital core of the programming platform created by MKS software. In addition to the MKS

Toolkit, it is now possible to have:

- MKS RCS™ (Revision Control System)
- MKS Make™ (automated program builder)
- MKS LEX&YACC™ (compiler construction tools)
- MKS SQPST™ (enhanced Documentor's Workbench™)

Additive Software!

The MKS Toolkit offers you power and diversity. Here is a complete list of commands you receive in the package:

| | | | |
|----------|----------|----------|------------|
| alias | ed | let | sort |
| awk | env | line | split |
| banner | eval | login | strings |
| basename | ex | ls | strip |
| bdiff | exec | mkdir | sum |
| break | exit | more | switch |
| c | expand | mv | sync |
| cal | export | nl | tail |
| case | expr | nm | tee |
| cat | false | od | test |
| cd | fc | pack | [|
| chdir | fg | passwd | time |
| chmod | file | paste | times |
| cmp | find | pcat | touch |
| :(colon) | fmt | pg | tr |
| comm | fold | pr | trap |
| compress | for | print | true |
| continue | function | prof | tty |
| cp | getopt | ps | type |
| cpio | glob | pwd | typeset |
| crypt | grep | r | ulimit |
| ctags | fgrep | read | unalias |
| cut | grep | readonly | uname |
| date | gres | return | uncompress |
| dd | hash | rev | unexpand |
| deroff | head | rm | uniq |
| dev | help | rmdir | unpack |
| df | history | rsh | unset |
| diff | if | sed | unstrip |
| diff3 | init | set | until |
| diffh | integer | sh | vi |
| dirname | jobs | shift | wc |
| .(dot) | join | size | whence |
| du | kill | sleep | which |
| echo | lc | spell | while |
| | | | who |

No wonder our users call it additive software!

System Requirements:

The MKS Toolkit works on IBM PC, XT, AT, PS/2 and compatible machines under DOS 2.1 and higher or under OS/2. A hard disk is recommended for improved performance and convenience.

Order Information

Price: \$199 for MKS Toolkit, \$495 for OS/2.
30-day money-back guarantee

1-800-265-2797 (continental U.S. only)
 1-519-884-2251 (outside continental U.S.)
 1-519-884-8861 (FAX)

Ask for Department BY



35 King Street North
 Waterloo, Ontario N2J 2W9 Canada

Safe and Secure?

*Unix comes with a lot of security features—
but it's up to you to turn them on and use them*

Patrick Wood

Unix security. To some computer people, these two words are mutually exclusive; to others, they refer to secure operating-system products for the Department of Defense (DoD). But what do they mean to you?

As general-purpose operating systems go, Unix has reasonably robust security. The problem is that most Unix systems are distributed with many of the security features turned off, and many administrators and users ignore security practices.

Many operating systems impose a default level of security that you can't circumvent. Unix, however, lets you set your own security standards. This is compatible with the Unix philosophy that the system shouldn't "get in the way"; anything you can turn on, you should also be able to turn off.

This philosophy goes back to the early days of Unix when dial-up lines were uncommon, hackers were just people who stayed up late at night playing computer games, and users were mostly interested in sharing data, not protecting it.

Unix was developed in a research-oriented environment at AT&T Bell Labs and, later, at various universities, so se-

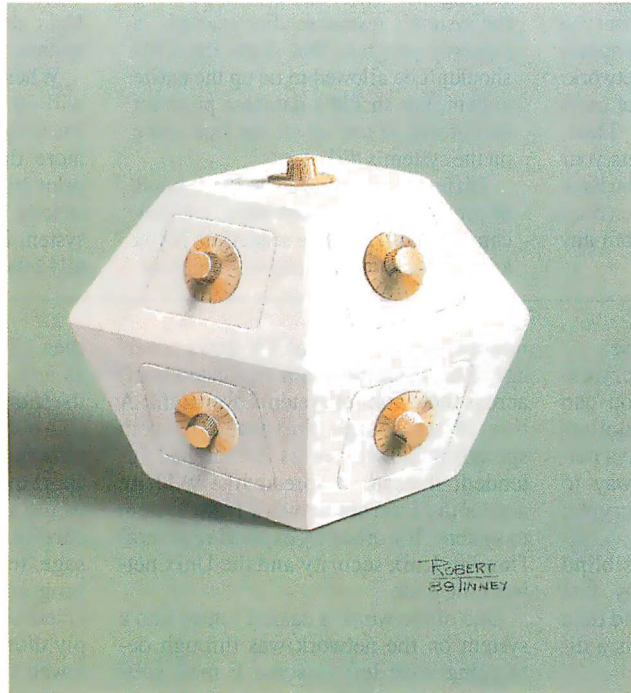

curity wasn't the first concern. For example, in an early version of `passwd`, the Unix password-changing program, you could set passwords to NULL and log in without having your password checked. Later versions of the program fixed that but still allowed very short passwords.

The current version of `passwd` on many Berkeley Unix systems asks you to use a longer password if you enter fewer

than five characters. However, if you insist by continuing to provide a short one, the program will relent and let you use it. The Unix versions based on AT&T's System V require a six-character password, and you can't get away with anything less.

Unix receives fairly high marks for its implementation of the four basic areas of computer security (see the text box "A Secure Base" on page 254), but some things do fall through the cracks.

The Crack in the Network

Unix is very compatible with networking: Many networks run on Unix systems, and a lot of networking software exists for them. A network constitutes an access path into the system, and some networking software and hardware aren't particularly good at preventing unauthorized access or compromise.

For example, Ethernet is a broadcast network, so all data that goes from one system to another is visible on the network. It's possible to have a system claim that it's another system. Most Unix networking software for Ethernet assumes that the network addresses are correct, so if you have a network test system, it's

continued

A Secure Base

You can divide computer security into four major areas: preventing unauthorized access, preventing compromise of data, preventing denial of service, and preserving system integrity. I'll consider them one at a time.

• *Preventing unauthorized access.* This is perhaps the most important part of any system's security: keeping the "bad guys" off the system. Most multiuser systems require that you go through a validation process before gaining access. This usually entails signing onto the system with a unique name that identifies who you are and then entering a password (in theory, unique and known only to you and to the system) that proves you are who you say you are. The Unix mechanism that handles this validation is called `login`.

Some systems have several validation levels: They may request an extra password when you call in to the system over the public telephone network, or you may need a special password to access privileged information or a network. Special modems can keep a list of users and their telephone numbers. Thus, when you call in, the modem gets your user name, hangs up, and calls you back at a preprogrammed number. Such dial-back systems prevent attacks from any but a few known numbers.

• *Preventing data compromise.* Once on the system, even authorized users shouldn't be able to delete, modify, or even look at other users' files without permission. Most systems implement some form of protection for users' files, although, surprisingly enough, not all do. Some multiuser systems require a separate add-on package to implement file protection.

Unix has a built-in protection scheme that lets you protect files against reading, writing, and/or executing by everyone else on the system, a predefined group, or even yourself. Other systems allow even finer control over file access: They let you permit or deny access on a per-user basis (e.g., `joe_t` and `mary_b` can read this file, or everyone can read this file except `bill_s`).

• *Preventing service denial.* You shouldn't be able to prevent others on the system from doing their work, accessing their files, and otherwise using the system's resources. For example, a runaway program that grabs the CPU shouldn't be allowed to tie up the entire system, nor should a database program be allowed to use up all the free space on the system's disk.

Different systems handle these kinds of problems in different ways, and few can handle all possible scenarios. If you know a lot about the internal organiza-

tion of a particular system, you can usually figure out how to run it "hard," Unix included. In particular, Unix isn't very good at preventing disk overuse.

• *Preserving system integrity.* You shouldn't be able to crash the system consistently; there should be no conditions under which an unprivileged user's program can overwrite system tables or otherwise corrupt the system. In other words, a system shouldn't be reliably unreliable.

Most systems are structured so that you don't share memory with the system, and the operating system's memory is protected from your programs. Similarly, user programs are usually protected from each other. This scheme tends to depend on hardware support for protected memory. Systems designed around older microprocessors, like the Intel 8086, simply are not able to provide this form of protection. However, most modern-day implementations of Unix do separate the users from the system.

When the system does crash—and it will—it should maintain data integrity. Files shouldn't be corrupted or lost for more than a few seconds or minutes prior to the crash. Although this isn't strictly a security issue, it is related to system integrity and is, therefore, usually bundled in.

easy to masquerade as someone else.

These test systems used to be very expensive (about \$50,000); now you can get software for a few hundred dollars that turns your microcomputer into a network monitor. About the only way to guard data in this situation is to encrypt it with specialized hardware.

Some networking software puts blind trust in the network, accepting any data that comes over the network as valid data and not garbage. Obviously, this is a disaster waiting to happen.

In general, a network of any kind has so many potential security problems that you should think of it as a single system whose security is only as strong as its weakest link.

The Worms Crawl In . . .

Perhaps the most publicized computer security breach to date occurred last November and affected about 7000 Unix systems. First billed as a virus, but technically a worm, it received front-page

newspaper and national TV-news coverage. The worm program replicated itself across thousands of systems overnight. A bug in its design prevented it from spreading slowly, as its author had intended; instead, it spread like wildfire across the Internet network from system to system. It worked by exploiting several flaws in Unix security and the Unix networking code.

One of the worm's easiest routes into a system on the network was through debugging code left in some E-mail software to allow system administrators to test the system remotely. This code allowed someone from another system to tell it to "do this," and the program would do it without checking first to see what it was.

The worm could also look at files on the local system to figure out which remote systems the users could access from the local system without a password. (This is fairly easy for a user to set up with the Berkeley Unix networking util-

ities.) The worm would then masquerade as any of those users and run a copy of itself on the remote system.

Another path was to try to crack the remote systems' passwords by testing a short dictionary against them. The worm would also try to gain access by sending a carefully constructed "garbage" message to a remote network-monitoring program. The program, compiled with a fixed-size array for incoming data, simply didn't limit the data it read. This allowed the worm to selectively overwrite parts of the program's memory, forcing it to perform actions it wasn't designed to do—like copying and running the worm.

All in all, the worm proved harmless, except for lost time and aggravation, but it provided good lessons in security: Never put code into production that contains a back door into the system; don't use short, easy passwords—they are too easy to guess; check all input to a privileged program that receives data from an

continued

Our MAJOR ADVANTAGE- Supplying you with the Broadest Range of Software Ammunition.



ADVANTAGE SOFTWARE

| LIST OURS | |
|-------------------------|---------|
| BACKUP UTILITIES | |
| Copy II PC | 40 25 |
| Copy II PC Option Board | 159 109 |
| D& Backup + | 80 45 |
| Fastback Plus | 189 109 |
| Intelligent Backup | 150 129 |

| CALL CALL | |
|-------------------|---------|
| CAD | |
| AutoCAD | |
| AutoSketch | |
| (Speed Enhanced) | 90 65 |
| Design CAD 3-D | 299 159 |
| Drafix CAD Ultra | 395 259 |
| Drafix 3D Modeler | 295 199 |
| Generic Products | |
| Schema II | 495 439 |

| COMMUNICATIONS | |
|---------------------|---------|
| Carbon Copy + | 195 119 |
| Close Up - Customer | 195 143 |
| Close Up - Support | 245 189 |
| Crosstalk MK IV | 245 125 |
| Crosstalk XVI | 195 99 |
| Procomm PLUS | 75 52 |
| Relay Gold | 250 159 |
| Smartcom III | 249 149 |

| DATABASE | |
|-----------------------|----------|
| Clipper | 695 439 |
| dBASE III + | 695 395 |
| dBASE IV | 795 485 |
| dBASE IV Dev. Edition | 1295 849 |
| FoxBASE + | 395 219 |
| Genifer | 395 259 |
| Paradox 3.0 | 725 543 |
| PC/Focus | 1295 779 |
| R & R | 149 109 |
| R-Base for DOS | 725 479 |
| Tom Reffig's Library | 80 75 |

| DESKTOP ANIMATION | |
|-------------------|---------|
| GRASP 3.1 | 149 129 |
| PC Emcee | 995 789 |
| Showpartner FX | 350 279 |

| DESKTOP PUBLISHING | |
|----------------------------|---------|
| Adobe Illustrator 88 (MAC) | 495 359 |
| ByLine | 295 180 |
| GEM/3 Desktop Publisher | 299 179 |
| Pagemaker | 595 429 |
| PFS: First Publisher | 129 79 |
| Ventura Desktop Publisher | 899 519 |

| DISK MANAGEMENT | |
|-----------------|--------|
| Flash | 70 49 |
| Mace Gold | 149 79 |
| Mace Utilities | 99 55 |
| PC Tools Deluxe | 79 40 |
| V Cache | 60 45 |
| Xtree | 70 37 |
| Xtree Pro | 129 69 |

| INFORMATION MANAGERS | |
|----------------------|---------|
| Agenda | 395 291 |
| askSam | 295 209 |
| DayFlo Tracker | 100 90 |
| Gofer | 80 43 |
| GrandView | 295 159 |
| Notebook II | 189 141 |
| Tornado w/ Libraries | 150 109 |
| ZIndex Professional | 295 159 |

| LANGUAGES | |
|---------------------------|---------|
| APL-PLUS | 695 476 |
| C.talk | 150 135 |
| Lahey FORTRAN F77L | 477 453 |
| Latice C | 450 229 |
| Microsoft C | 450 299 |
| NDP Fortran or C-386 | 595 529 |
| Phar Lap 386/ASM/LINK | 495 399 |
| Turbo C | 150 112 |
| Turbo C Professional | 250 187 |
| Turbo Pascal | 150 112 |
| Turbo Pascal Professional | 250 187 |
| Zortech C + | 150 122 |

| LANGUAGE UTILITIES | |
|----------------------|-----------|
| Brief | 195 CALL |
| db_File | 395 322 |
| db_Retrieve | 395 322 |
| Flowcharting II Plus | 229 145 |
| HALO '88 | 325 229 |
| Interactive Easyflow | 150 135 |
| Matrix Layout | 150 101 |
| Periscope I | 795 675 |
| Periscope III | 1395 1255 |
| Vermont Views | 395 CALL |
| Vq | 270 CALL |

| LOTUS ADD-ONS | |
|---------------|---------|
| 4Views | 150 119 |
| 4Word | 100 61 |
| @bASE | 195 121 |
| Allways | 150 91 |

| LIST OURS | |
|-----------------------|----------|
| At Liberty | 99 92 |
| Graph-In-the-Box | 140 109 |
| Inword | 100 CALL |
| Look & Link | 100 64 |
| Note-It Plus | 80 49 |
| Noteworthy | 80 49 |
| R & R [Lotus Version] | 149 109 |
| See More | 80 49 |
| Sideways | 70 43 |
| Smartnotes | 80 69 |
| Spell!nt | 80 49 |
| Sqzi Plus | 100 61 |

| PRESENTATION GRAPHICS | |
|-------------------------|----------|
| Concorde | 695 509 |
| Diagraph | 395 242 |
| Draw Applause | 495 303 |
| Freelance Plus | 495 322 |
| GEM Graph Present. Pack | 495 309 |
| GRAPH Plus | 395 CALL |
| Graph-In-the-Box | 140 109 |
| Harvard Graphics | 495 289 |
| Microsoft Chart | 395 265 |
| PIXIE | 195 CALL |
| Xerox Presents | 495 325 |

| PROJECT MANAGEMENT | |
|----------------------------|---------|
| Harvard Total Project Mgr. | 595 449 |
| Micro Planner | 595 419 |
| Project 4.0 | 495 340 |
| Super Project Plus | 495 267 |
| Time Line 3.0 | 595 345 |

| SCIENCE AND ENGINEERING | |
|------------------------------|-----------|
| Asystant Plus | 895 849 |
| DADISP | 795 719 |
| Eureka: The Solver | 167 119 |
| Gauss Math + Stat Package | 395 359 |
| HiWire-Plus | 895 805 |
| Labtech Notebook | 995 799 |
| MathCAD | 349 225 |
| Micro-Cap III | 1495 1269 |
| smARTWORK | 895 805 |
| T3 Scientific Word Processor | 595 499 |
| Tango PCB Series II | 595 559 |
| TECH*GRAPH*PAD v.3.0 | 395 379 |
| TK Solver Plus | 395 349 |

| SPREADSHEET | |
|-------------------|----------|
| LOTUS 1-2-3 | 495 289 |
| Lucid 3-D | 149 139 |
| Multiplan | 495 129 |
| PC-Excel | 495 299 |
| Qualtro | 248 185 |
| Silk | 298 CALL |
| Supercalc V 20/20 | 495 329 |
| | 500 CALL |

| STATISTICS | |
|----------------|---------|
| CSS | 495 459 |
| Microstat II | 395 349 |
| NWA Statpak | 399 359 |
| SPSS/PC | 795 729 |
| STATGRAPHICS | 895 569 |
| Systat | 595 489 |
| Systat/Sygraph | 795 679 |

| LIST OURS | |
|--|-----------|
| 386 OPERATING SYSTEMS/ CONTROL PROGRAMS | |
| Concurrent DOS 386 (3 User) | 395 239 |
| DESQview 386 w/QEMM | 190 169 |
| Microsoft Windows/386 | 195 130 |
| SCD Sys. V 386 (Complete) | 1495 1195 |
| VM/386 | 245 209 |

| WORD PROCESSING | |
|------------------------|---------|
| Displaywrite IV | 495 349 |
| Manuscript | 495 322 |
| Multimate Advantage II | 565 271 |
| PC-Write 3.0 | 89 69 |
| Q & A Write | 349 207 |
| Samna Word IV | 595 313 |
| Volkswriter V3 | 295 170 |

| LIST OURS | |
|-------------------------|---------|
| Full Write Professional | 295 236 |
| Map Master v. 6.01 | 395 240 |
| Multimate Advantage II | 565 271 |
| Rapid File | 295 195 |
| Sign Master | 245 139 |

| BORLAND | |
|-------------------------------|---------|
| Eureka: The Solver | 167 126 |
| Paradox 3.0 | 725 543 |
| Paradox 386 | 895 671 |
| Qualtro | 248 185 |
| SideKick Plus | 200 149 |
| Sprint | 199 149 |
| Superkey | 100 75 |
| Turbo Assembler/Debugger | 150 112 |
| Turbo Basic | 100 75 |
| Turbo C 2.0 | 150 112 |
| Turbo C 2.0 Professional | 250 187 |
| Turbo Pascal 5.0 | 150 112 |
| Turbo Pascal 5.0 Professional | 250 187 |
| Turbo Prolog | 150 112 |

| LOTUS DEVELOPMENT | |
|----------------------------|---------|
| Agenda | 395 291 |
| Freelance + Graphwriter II | 495 322 |
| Hal | 150 89 |
| Lotus 1-2-3 | 495 289 |
| Lotus Metro | 85 59 |
| 1-2-3 Report Writer | 95 69 |
| Manuscript | 495 325 |
| Signal | 595 396 |
| Symphony | 695 422 |

| MICROSOFT | |
|--|---------|
| MS BASIC/6.0 | 295 199 |
| MS C | 450 299 |
| MS COBOL | 900 599 |
| MS Excel | 495 249 |
| MS FORTRAN | 450 299 |
| MS Learning DOS | 50 40 |
| MS Mach 20 | 495 329 |
| MS Macro Assembler | 150 99 |
| MS Mouse Bus or Serial w/Painbrush & Mouse Menus | 150 99 |
| w/EasyCAD | 175 119 |
| w/Painbrush & Windows | 200 139 |
| MS Multiplan | 195 129 |
| MS OS/2 Prog. Toolkit | 350 229 |

PRIMARY TARGET MICROSOFT WORD 5.0

Word 5.0 has new features that solve the toughest word processing problems, yet it offers unprecedented ease of use. The interface has been streamlined, and all formatting options are now shown on screen, offering better flexibility and control when editing and printing.

New 5.0 productivity tools include macros, to automate long sequences of commands; Print Preview, to see how documents will look before they are printed; easier ways to integrate data, text and graphics; a new Show Layout option for editing columns on screen; a greatly expanded Help index and much more.

List: \$450 Ours: \$240

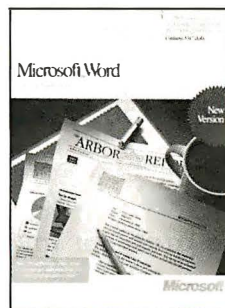

Microsoft®

| LIST OURS | |
|---------------------|---------|
| Word 5.0 | 450 240 |
| Word Perfect v. 5.0 | 495 249 |
| Wordstar Pro v. 5.0 | 495 245 |

| ASHTON TATE | |
|------------------------------|----------|
| ByLine | 295 180 |
| ChartMaster | 375 205 |
| ChartMaster Premium Pack | 395 225 |
| dBASE III + | 695 385 |
| dBASE IV | 795 845 |
| dBASE IV Developer's Edition | 1295 849 |
| dBASE Mac | 495 325 |
| Diagram Master | 345 190 |
| Diagram Master Prem. Pack | 365 206 |
| Draw Applause | 495 303 |
| Framework III | 695 405 |
| Front Runner | 195 121 |
| Full Paint | 100 65 |

| LIST OURS | |
|-----------------------|---------|
| MS Pascal | 300 199 |
| MS Project 4.0 | 495 340 |
| MS QuickBASIC | 99 69 |
| MS QuickC | 99 69 |
| MS Sort | 195 130 |
| MS Windows | 99 69 |
| MS Windows/386 | 195 130 |
| MS Windows/Devel. Kit | 500 319 |
| MS Word 5.0 | 450 240 |
| MS Works | 149 99 |

| PETER NORTON PUBLISHING | |
|-----------------------------|---------|
| Norton Commander | 89 55 |
| Norton Editor | 75 50 |
| Norton Guides:OS/2 | 150 109 |
| Norton Guides:Specify Lang. | 100 75 |
| Norton Utilities | 100 59 |
| Advanced Version | 150 99 |

Terms & Policies

All prices subject to change without notice. We accept Visa, MC, AMEX (2% surcharge on AMEX). Shipping \$4 per item sent UPS Ground. Allow 14 days for personal/company check clearance. Returns subject to 15% restocking fee. RA # required. PO's welcome from Fortune1000 and other qualified organizations.



ADVANTAGE SOFTWARE

A Division of Voyager Software Corp
Circle 13 on Reader Service Card

In the U.S. call:
1-800-333-3141
N.Y. / International **914-332-0756**
Fax: **914-332-4021**

55 South Broadway, Suite B, Tarrytown, NY 10591

Subscription Problems?



We want to help!

*If you have a problem with your **BYTE** subscription, write us with the details. We'll do our best to set it right. But we must have the name, address, and zip of the subscription (new and old address, if it's a change of address). If the problem involves a payment, be sure to include copies of the credit card statement, or front and back of cancelled checks. Include a "business hours" phone number if possible.*

BYTE

Subscriber Service
P.O. Box 7643
Teaneck, NJ 07666-9866



uncontrollable source; beware of networking software that allows you to access systems without some form of authentication. None of the loopholes the worm used are deficiencies in Unix per se; they are due to poor programming or user practices.

A Nasty Virus

There is an important distinction between a worm and a virus. A worm spreads around a network by copying itself from system to system, but it doesn't necessarily alter the systems in any way. A virus, on the other hand, spreads by attaching itself to another program; when you run that program, the virus attaches itself to more programs. Over time, a virus can "infect" all the programs on your system. A worm is self-contained; it doesn't infect anything.

If a virus-infected program moves around a network or if files are accessible across a network, the virus can infect the entire network and any system attached to it. Unix viruses have been created and are very difficult to prevent. You can also have a hybrid worm that is a cross between a worm and a virus. The hybrid worm injects its virus into each system it enters. When the Internet worm first appeared, the main concern of those affected was that it might be a hybrid.

The most publicized viruses to date have been on MS-DOS microcomputers and Macintoshes. A virus is designed for a particular piece of hardware and/or operating system. There are more MS-DOS microcomputers and Macs than any one specific Unix box, and thus the epidemic has hit them hardest. (The Internet worm was restricted to Sun workstations and DEC VAXes running Berkeley Unix.)

The Trojan Horse

A Trojan horse is an old security trick: It's a program that appears to do something useful; however, it also does something harmful, such as deleting random files or creating a setuid program (one that always runs with owner permission).

A Trojan horse can be made to look like a system command and then placed in a directory where you'll run it instead of the actual command. Since Unix lets you specify the PATH (a list of directories to search when you enter a command), if the current directory is farther up the list than the system directories, you'll run the horse. Most of the older Unix versions and some of the current ones use a default search PATH that lists the current directory first.

You can think of a virus as a Trojan horse with an infection. When you run

an infected program, it does something useful and something nefarious: It infects other programs.

Mail Bombs

A mail bomb is a mail message that makes use of a dangerous feature of many "smart" terminals: It contains an escape sequence that causes the terminal to send data on the screen back to the host system. For example, a mail bomb might print `cd $HOME; rm -rf * &` on the screen followed by a "retransmit" escape sequence. This line will silently delete all your files. And if the bomb is clever, it will then delete the line from the screen using another escape sequence.

Fortunately, mail bombs are hardware-specific and manufacturer-specific, so a mail bomb designed for a Hewlett-Packard terminal won't work on a DEC VT-220, and vice versa; however, considering the current volume of E-mail traffic (multimegabytes per day), mail bombs could pose a serious threat.

Permission, Please

The file permissions on Unix are an obvious way to prevent compromising data. If your file permissions are correct, nobody knows your password, the system administrator isn't snooping in your data, and no one has broken the system's security, your files are safe. Many users, however, don't know what file permissions are, let alone how to use them.

On most Unix systems, new users are all added to the same group if the system administrator selects the default settings. Even on systems with fairly secure default permissions, users in your group can usually read your files, and on many systems they can read and *write to* your files. Thus, users who shouldn't share data end up doing so without knowing it.

Just Who's Running This Program?

Perhaps one of the biggest cracks in Unix security is one of its best features: the setuid capability. An executable binary file can have its permissions set so that it always runs with the owner's permissions, *no matter who executes it*. When it runs, it runs as if the owner of the program were running it. This feature can allow anyone to execute programs that access restricted files. The capability assumes that such a program performs some kind of checking when it is run.

For example, the `passwd` program allows you to change your password. Passwords are stored in an encrypted form in the file `/etc/passwd`. For `passwd` to change your password, it must be able to write to `/etc/passwd`. There

SAVE \$17



IBJ5666

Subscribe to BYTE now and save \$17 off the newsstand price of \$42.00... and \$5.00 off the regular subscription rate of \$29.95. You'll also receive our special IBM PC issue as part of your subscription.

USA \$24.95/1 year Canada \$26.95 U.S./1 year

Bill me

Payment enclosed

Charge to my VISA MasterCard

Account # _____

Expires _____

Signature _____

This is a renewal order.

Name _____

(Please Print)

Company _____

Address _____

City/State _____

Country _____ Code _____

For direct ordering, call toll free 1 800 257-9402 weekdays
9:00 AM-5:00 PM EST. In New Jersey, call 1 609 426-5535.

Please allow 6-8 weeks for processing your subscription.



SAVE \$17



IBJ5666

Subscribe to BYTE now and save \$17 off the newsstand price of \$42.00... and \$5.00 off the regular subscription rate of \$29.95. You'll also receive our special IBM PC issue as part of your subscription.

USA \$24.95/1 year Canada \$26.95 U.S./1 year

Bill me

Payment enclosed

Charge to my VISA MasterCard

Account # _____

Expires _____

Signature _____

This is a renewal order.

Name _____

(Please Print)

Company _____

Address _____

City/State _____

Country _____ Code _____

For direct ordering, call toll free 1 800 257-9402 weekdays
9:00 AM-5:00 PM EST. In New Jersey, call 1 609 426-5535.

Please allow 6-8 weeks for processing your subscription.





NO POSTAGE
NECESSARY
IF MAILED
IN THE
UNITED STATES

BUSINESS REPLY MAIL

FIRST CLASS MAIL PERMIT NO. 42 HIGHTSTOWN, NJ

POSTAGE WILL BE PAID BY ADDRESSEE

BYTE

Subscription Department
P.O. Box 558
Hightstown, N.J. 08520-9409



NO POSTAGE
NECESSARY
IF MAILED
IN THE
UNITED STATES

BUSINESS REPLY MAIL

FIRST CLASS MAIL PERMIT NO. 42 HIGHTSTOWN, NJ

POSTAGE WILL BE PAID BY ADDRESSEE

BYTE

Subscription Department
P.O. Box 558
Hightstown, N.J. 08520-9409

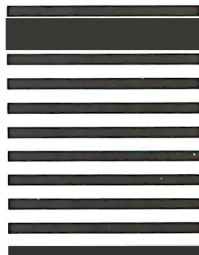

is no special system call for modifying `/etc/passwd`; the `passwd` program must do it using standard Unix reading and writing routines. But if you look at the program file `/bin/passwd`, you'll see that it has a special file permission set: the `setuid` permission.

The superuser (`root`) also owns `passwd`, and when it runs, it has full access to the system and can overwrite any file it wants to, including `/etc/passwd`. The `passwd` program is designed to change your password only after you have entered your old password, identifying yourself as that user. Only then can you enter a new password.

So, if `setuid` programs are well designed, why the fuss? Unfortunately, most `setuid` programs aren't well designed. Some of them have some glaring holes that allow regular users to become the superuser with little effort. The problem isn't with the `setuid` concept per se; it's with the overuse and misuse of it. In principle, you should use `setuid` only when there is no other way to accomplish a particular function. In practice, it's used whenever it's the easiest way.

The Orange Book

The National Computer Security Center, a part of the DoD, published a document at the end of 1985 called the "Department of Defense Trusted Computer System Evaluation Criteria." Known as the Criteria, or just the Orange Book (due to its bright orange cover), this document has had far-reaching effects on the computer-security industry. It sets the standards and requirements for the secure systems that the DoD will purchase. If the NCSC prevails, over the next few years, most, if not all, systems purchased by the U.S. government will have to meet some minimum level of security as specified in the Orange Book.

The Orange Book divides computer security into four broad divisions:

- Division D: minimal protection (i.e., any system that fails to pass in divisions A, B, or C).
- Division C: discretionary protection (i.e., you decide what protections to enforce, like the Unix file permissions).
- Division B: mandatory protection (i.e., the system enforces some form of protection that is not under your control).
- Division A: verifiable protection (i.e., you must prove that the security model and/or the implementation are secure).

continued

Table 1: The Orange Book's seven classes of security and beyond.

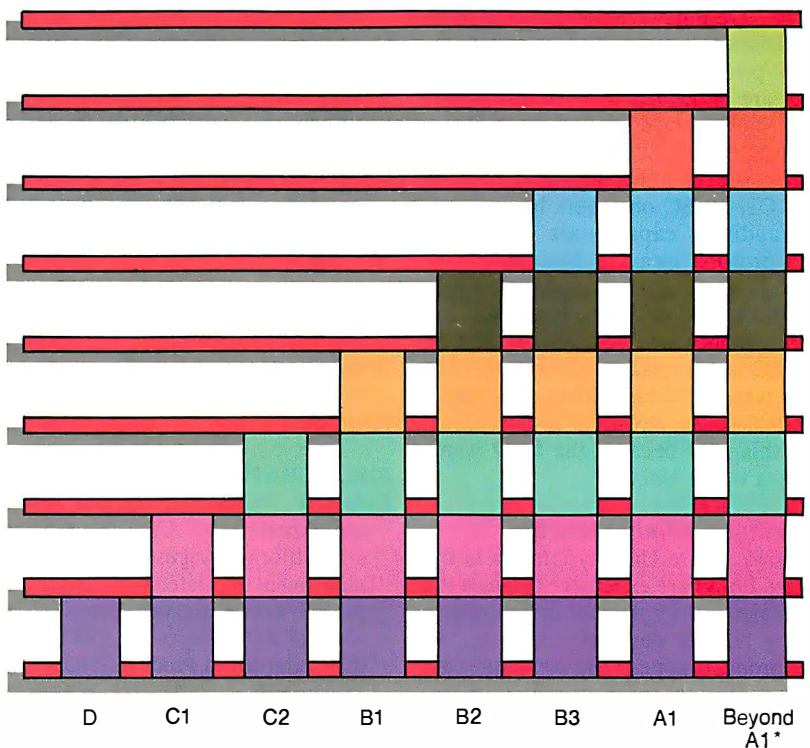

- Minimal security
- Security controls much like Unix's, including:
Log-in verification
Discretionary controls for users and groups
Documentation of security features and their implementation
- Audit trails of security violations
Stricter log-in controls
Resource separation and strict object (disk and memory) reuse policy
- Mandatory access controls
"Labeling" of objects (like permissions but more comprehensive)
Labeling of output and "exported-data" tapes
- Formal security policy for the operating system (a model)
Greater use of labels
Separation of operator and administrator functions
- Ability to specify permissions on a per-user and per-group basis
Security administrator log-in with special privileges
"Modular design" of security system
Trusted recovery (restore after crash or reload of operating system)
- Security algorithms must be formally verified
- Proven correctness of hardware and firmware
Proven correctness of development tools
Formal verification of source code

* Beyond A1 isn't possible with current software and hardware technology.

The divisions are hierarchical—each higher division assumes all the requirements of the lower ones. Thus, Division B must have the discretionary protection from Division C as well as its own mandatory protection. The divisions themselves are divided into seven levels. Security increases as the numbers go up within a division (see table 1).

Unix fits into this alphabet soup at about C1. NCSC observers believe that with auditing capabilities System V would probably be at C2. Most people involved in implementing secure Unix systems think that the highest level Unix can reach without a total redesign of the kernel is B2 and that B2 would require 25 to 50 person-years of effort to implement. Companies are devoting resources toward this goal because the DoD wants Unix—a secure Unix.

The Future of Unix Security

For now, secure Unix systems (à la the Orange Book) are expensive because the companies that implement these systems have to recover development costs. As more products appear and companies get more experience with secure systems,

costs will come down, but secure Unix systems are sure to remain more expensive than those that are not secure.

Fortunately, products that improve Unix security are available. Some of them are USECURE from Unitech Software (Vienna, VA), SysAdmin from Uni-Solutions Associates (Culver City, CA), PassPort from Sytek (Mountain View, CA), SafeWord from Enigma Logic (Concord, CA), and Kerberos from MIT's Project Athena (Cambridge, MA). ■

Editor's note: *Security programs from Unix System Security (Howard W. Sams, 1985) are available as security.shar in the "listings" topic of the unix conference on BIX. See page 3 for details.*

BIBLIOGRAPHY

Cohen, F. "Computer Viruses: Theory and Experiments." University of Southern California (August 1984).

"Department of Defense Trusted Computer System Evaluation Criteria." DoD 5200.28-STD, December 1985, Office of Standards and Products, NCSC, Fort Meade, MD.

Filipski, A., and J. Hanko. "Making UNIX Secure." *BYTE*, April 1986, pp. 113-128.

Grampp, F. T., and R. H. Morris. "The Unix System: Unix Operating System Security." *AT&T Bell Laboratories Technical Journal*, vol. 63, no. 8, part 2 (October 1984), pp. 1649-1672.

Steiner, J., C. Neuman, and J. Schiller. "Kerberos: An Authentication Service for Open Network Systems." Project Athena, MIT.

Thompson, K. "Reflections on Trusting Trust." *1983 ACM Turing Award Lecture, CACM*, vol. 27, no. 8 (August 1984), pp. 761-763.

Wood, Patrick, and Stephen Kochan. *Unix System Security*. Indianapolis, IN: Howard W. Sams, 1985.

Patrick Wood is vice president of Pipeline Associates in Hiawatha, New Jersey. He is also the author of four books on the Unix system, including Unix System Security (Howard W. Sams, 1985), and consulting editor to Howard W. Sams's Hayden Unix Library. He can be reached on Usenet as "decvax!pipeline!phw" or on BIX as "patwood."

PCYACC™ Version 2.0

PROFESSIONAL LANGUAGE DEVELOPMENT TOOLKIT

Professional Version \$395.00—Personal Version \$139.00

Includes "Drop In" Language Engines for SQL, dBASE, POSTSCRIPT, HYPERTALK, SMALLTALK-80, C++, C, PASCAL, and PROLOG.

PCYACC Version 2.0 is a complete Language Development Environment that generates ANSI C source code from input Language Description Grammars for building Assemblers, Compilers, Interpreters, Browsers, Page Description Languages, Language Translators, Syntax Directed Editors, and Query languages.

Complete grammars, Lexical Analyzers, and Symbol Table Management for ANSI C, K&R C, ISO Pascal, dBASE III/Plus and IV, SQL, C++, Smalltalk-80, APPLE HyperTalk, C&M Prolog, YACC, LEX, and POSTSCRIPT are included. OS/2 and MAC versions are available.

Example application sources are provided to be used as skeletons for new programs. Examples include a desktop calculator, an Infix to Postfix Translator, a dBASE and SQL Syntax analyzer, an implementation of the PIC[ture] language, and a C++ to C translator.

- Lexical Analyzer Generator ABRAXAS PCLEX is included
- Quick Syntax analysis option
- Optional Abstract Syntax Tree
- Advanced Error recovery Support Provided
- Manual "Compiler Construction with PC'S" included
- All examples include FULL SOURCE
- 30 day money back guarantee
- No charge for shipping anywhere in the world

To order, please call
1-800-347-5214



**ABRAXAS™
SOFTWARE, INC.**

7033 SW Macadam Ave. Portland, OR 97219 USA
TEL (503) 244-5253 · FAX (503) 244-8375
AppleLink D2205 · MCI ABRAXAS

Introducing The UnTerminal.™

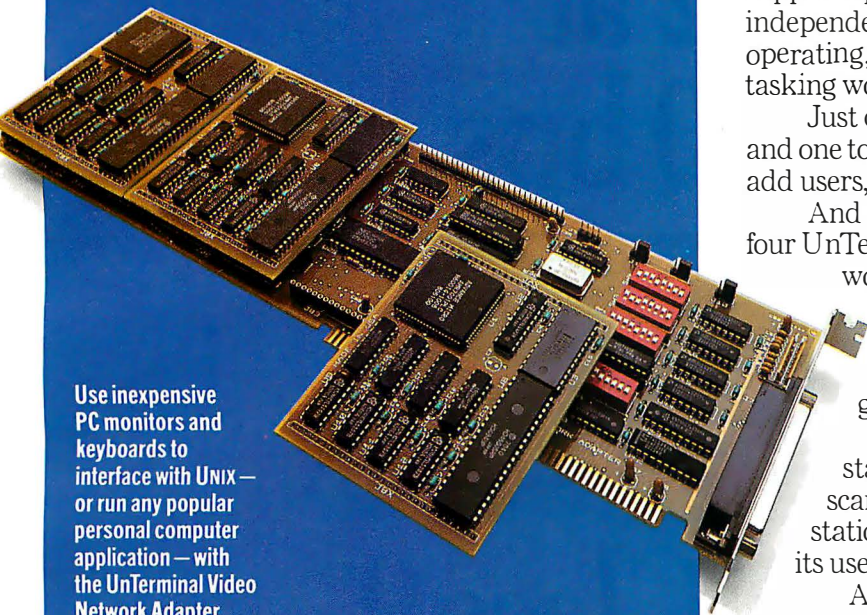

Use inexpensive PC monitors and keyboards to interface with UNIX — or run any popular personal computer application — with the UnTerminal Video Network Adapter.

Terminals are too slow. Too expensive. Too limited. Too inflexible. Too outdated. In a word, too dumb.

Because now there's the UnTerminal Video Network Adapter.™

It lets you deliver all the advantages of the UNIX® environment.



THIS IS NOT A TERMINAL

With none of the disadvantages of terminals.

With the UnTerminal, users can work exactly as if they had their own PCs. Because in essence, they do.

Unless they're working exactly as if they were on a high-performance UNIX system. Because in fact, they are.

The UnTerminal lets you connect PC monitors and keyboards to the "virtual PCs" designed into the 386's architecture.

Which lets you exploit the 386's ability to run DOS under UNIX — while you also take advantage of its ability to run high-performance UNIX or XENIX®



NO TERMINALS HERE, PAL

applications.

Each UnTerminal video network adapter card can



THIS ISN'T A TERMINAL, EITHER

support up to four independently operating, multi-tasking workstations.

Just connect one workstation to the card itself, and one to each of three "piggyback" minicards as you add users, bringing the total to four.

And a single 386-based system can support up to four UnTerminal cards, bringing the total number of workstations to sixteen.

UnTerminal workstations are better, faster and cheaper than terminals.

They offer Hercules-compatible PC graphics.

You can attach a mouse or any other standard PC peripheral, such as a modem, scanner, plotter or printer, tailoring each workstation to the specific needs of its user.

And screens which would update tediously, line by line, on a terminal will refresh "instantly" on an UnTerminal workstation.

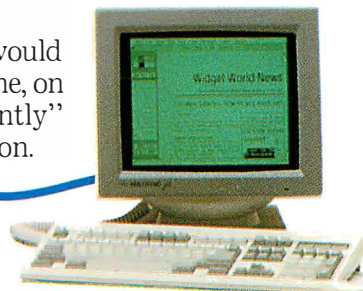

THIS STILL ISN'T A TERMINAL

About 25 times faster, in fact.

Best of all, these faster, more capable, easier-to-use UnTerminal workstations can actually cost far less.

So now it will be much easier to sell UNIX-based solutions into environments where the users are used to DOS.

They won't have to give up anything they like — like favorite applications, graphics or ease of use.

But they *will* be able to enjoy all the attractive benefits of your UNIX-based solution.

What's more, with the UnTerminal they can transfer information back and forth between the DOS and UNIX environments.

All of which makes dumb terminals seem dumber than ever, don't you think?

For more information or a complete demonstration, call Advance Micro Research at 415-594-9991.



The UnTerminal UNIX WITHOUT TERMINALS

Advance Micro Research, Inc., One Lagoon Drive, Redwood City, CA 94065-1562. Phone: 415-594-9991, Fax: 415-594-0112

The following are registered or unregistered trademarks of the companies listed: UnTerminal™ and Video Network Adapter,™ Advance Micro Research, Inc.; UNIX® AT&T; XENIX® Microsoft; Hercules® Hercules.

Now Providing Full UNIX Support.
Call For Details.

V.32 at 38,400 bps.



MNP[®] Class 9

Because life is too short
to use a slow modem.

We couldn't make our dial-up modems any more accurate. So we made one twice as fast. And it's available today.

Introducing QX/V.32c, the world's fastest dial-up modem. At 38,400 bps, with full-duplex CCITT V.32 compatibility over dial-up lines. Plus all the added performance and Enhanced Data Compression of MNP[®] Class 9. There's compatibility with V.22bis, V.22, Bell 212A and Bell 103 included, so that QX/V.32c communicates at optimum levels with modems of all speeds. And it can work in synchronous or asynchronous environments.

Speed and performance are not the only powerful features of the QX/V.32c. Its compact design is equally impressive—1/3rd the size of most competitive modems. And it comes in a rack mount version, as well.

What will you pay for our breakthrough V.32 modem? About the same as modems with only half the error-free throughput. As you can see from the chart, lower phone bills alone could pay for this upgrade.

9600 bps modem\$6.94

QX/V.32c...\$1.74

Comparable costs of sending identical amounts of data over dial-up lines.

Find out how Microcom brought error-free V.32 to 38,400 bps levels. Call toll-free 800-822-8224 today.



Workstation
Connectivity
Worldwide

500 River Ridge Drive, Norwood, MA 02062 617-551-1000 Telex 710-336-7802 MICROCOM NWD

Worldwide Distribution—International FAX: 617-551-1007 USA FAX: 617-551-1006

Toll-free 800-822-8224

MNP is a registered trademark of Microcom, Inc. QX/V.32c and Enhanced Data Compression are trademarks of Microcom, Inc.

Interrupts Aren't Always Best

The choice between interrupts and polling in a Unix device driver can significantly affect performance

George E. Pajari

The communications controller that connects users' terminals to the central system is a critical component in a Unix multiuser system. In fact, since processing the byte stream to and from a single user's terminal can consume over 50 percent of a CPU's time, communications is a surprisingly CPU-intensive activity. If half the CPU time is consumed in servicing a single terminal, the throughput of the system for the other users drops dramatically.

It is usually assumed that interrupts are the best way for serial devices to use CPU resources, but for a high-performance communications controller and its associated device driver, the interrupt system is not always best. Polling can frequently result in higher performance.

Before examining in detail the operation of Unix communications controllers and the related issues, I want to look at what a device driver is, the function of a Unix communications controller, what interrupts are, and what polling is.

Device Drivers

A device driver is a request translator. As figure 1 illustrates, the device sits be-

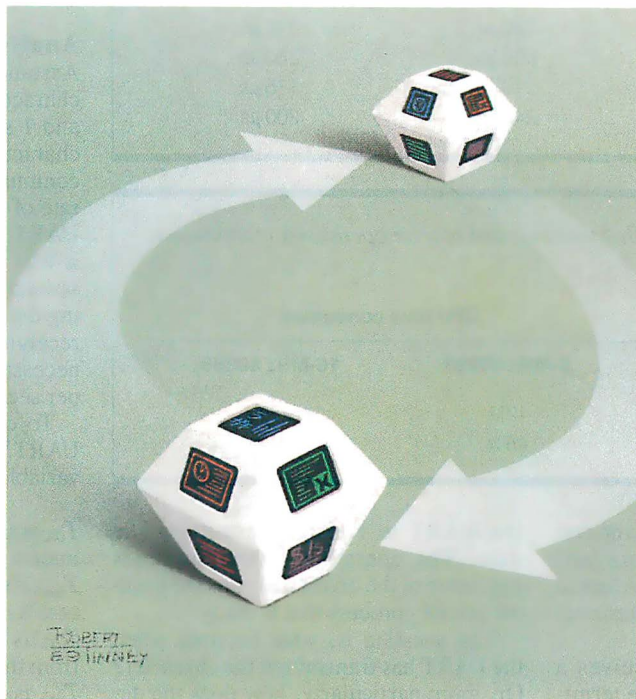

tween an operating system (in this case, Unix) and the hardware. The operating system issues a request (e.g., "Read hard disk sector 10991"), and the device driver translates that into the appropriate commands for the particular hard disk controller (e.g., "Read 1024 bytes starting at sector 9, head 5, cylinder 101; transfer data to the buffer at physical address 18C400; then interrupt the CPU").

The advantage of having device drivers is that the operating system can issue *generic* requests to devices without having to know about the details about each controller. Should a controller change, you need only change the driver. You can install new devices on the system without changing the operating system proper.

Serial Communications

In Unix systems, the method used to connect individual terminals to the central host is usually an asynchronous serial-communications line. The interface on the host computer handles communications between the host and one or more terminals (or modems). This serial-communications board is responsible for transmitting data to the terminals and receiving

data intended for the host.

The device driver for the serial-communications interface accepts requests from the operating system to transmit characters to a user, as well as requests to provide data received from a user.

Assume that you have a normal PC COM1: port. This communications interface is little more than a single chip

continued

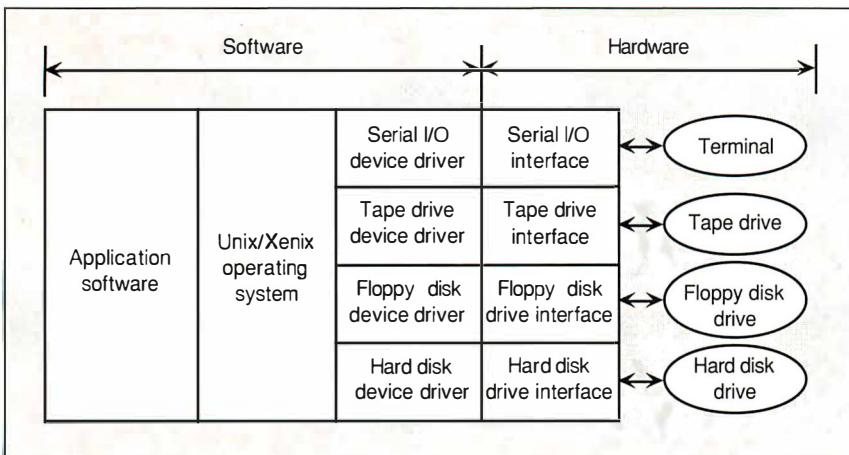

Figure 1: Device drivers (the big picture). The device driver sits between the operating system and the hardware.

Table 1: Timings for basic operations. T_{int} : CPU time to handle an interrupt; $T_{syscall}$: time spent handling a request; $T_{p \rightarrow u}$: time to copy and handle a byte from the process to the UART; $T_{u \rightarrow p}$: time to copy and handle a byte from the UART to the process.

| Variable | 8-MHz 80286 | 16-MHz 80386 |
|-----------------------|-------------|--------------|
| T_{int} | 220 μ s | 110 μ s |
| $T_{syscall}$ | 550 μ s | 280 μ s |
| $T_{p \rightarrow u}$ | 210 μ s | 175 μ s |
| $T_{u \rightarrow p}$ | 240 μ s | 200 μ s |

Table 2: Overhead for nonpolled transmit and receive operations (continuous operation at 9600 bps).

| Operation | CPU time consumed | |
|--------------|-------------------|--------------|
| | 8-MHz 80286 | 16-MHz 80386 |
| Transmitting | 42% | 28% |
| Receiving | 45% | 30% |

that receives bytes of data and converts them into serial asynchronous data (and vice versa). This chip is usually referred to as the UART (universal asynchronous receiver/transmitter).

When the device driver receives a string of characters to send to the terminal, it copies them into an internal buffer and then performs the necessary processing on the string (e.g., converting new lines into carriage return/new-line pairs, and so on). Next, it takes the first character to be transmitted and writes it to the *transmit data* register on the UART. The UART transmits this byte 1 bit at a time (e.g., 9600 bits per second). Meanwhile, the device driver informs the operating system that it is waiting for

the UART to finish transmitting the data. The operating system suspends execution of the driver and runs the high-priority process that is ready.

The question is, what happens when the UART has transmitted the character? Or, more particularly, how does the device driver know that the UART is ready for the next character?

The Purpose of Interrupts

Interrupts are one method of signaling the CPU that something has happened. In this case, the UART signals an interrupt when it has completed transmitting data and is ready to receive more data.

When a CPU receives an interrupt, it checks to see if the interrupt has been en-

abled. If it has not, the interrupt is ignored. If it has been enabled, the CPU stops what it's doing, saves some information in a designated area of memory so that the interrupted work can be resumed, and starts executing a part of the device driver known as the *interrupt handler*. The interrupt handler checks to see if there is more work to be done (i.e., bytes waiting to be transmitted) and, if so, places the next byte in the UART's transmit register. And so it goes. Write a byte to the UART. Transmit the byte. Interrupt the CPU. Run the interrupt handler. Repeat.

The process is much the same for incoming data. In this case, the UART receives a byte from the user's terminal a bit at a time and assembles it into a byte. When the entire byte has been received (5, 6, 7, 8, or 9 bits, depending on the coding scheme and parity), it interrupts the CPU. The interrupt handler takes the assembled byte from the UART's receive register and places it in an internal buffer. This internal buffer can then satisfy requests from the operating system for data from the user.

Analysis of Interrupts

Assume that the UART is handling 7-bit characters with 1 parity bit, 1 stop bit, and 1 start bit, for a total of 10 bits per character. If you also assume 9600-bps communications, you have an effective rate of 960 characters per second. If the UART is continuously busy transmitting, it will be generating 960 interrupts per second. Similarly, if the UART is receiving data at the capacity of the line (e.g., receiving a file using Kermit), it will necessarily be generating 960 interrupts per second.

To express the CPU overhead of the UART's operation, I have defined some variables:

T_{int} is the CPU time needed to handle an interrupt.

$T_{syscall}$ is the time spent handling a process's request to a device driver.

$T_{p \rightarrow u}$ is the time needed to handle a byte from the process to the UART.

$T_{u \rightarrow p}$ is the time needed to handle a byte from the UART to the process.

Then, the time required to transmit a line of data (say 64 bytes) is expressed as

$$T_{transmit-64} = T_{syscall} + 64 \times (T_{p \rightarrow u} + T_{int})$$

Similarly, the time required to receive a line of data is

$$T_{receive-64} = T_{syscall} + 64 \times (T_{u \rightarrow p} + T_{int})$$

Table 1 shows typical values for all these variables. Timings are from an 8-MHz IBM PC AT compatible and a 16-MHz 80386 machine, both running SCO Xenix. Table 2 shows the results of placing these values into the foregoing equations and converting the values to CPU overhead (assuming continuous 9600-bps operation).

As you can see, half of the 80286's time is consumed by the overhead of a single 9600-bps line. Even on a 16-MHz 80386 (which can usually handle 16 to 32 users), a single 9600-bps line can consume almost a third of the system. There must be a better way, and there is.

Polling

How would you design the device driver if you had a UART that could store data? And what would the performance be?

For starters, you would stop the UART from generating an interrupt every time it transmitted or received a character. When transmitting a string of data, you would write the entire string (up to the capacity of the UART's buffer) at one shot. The UART would then simply transmit data until it emptied its buffer, at which point it would interrupt the CPU. The interrupt handler would fill the UART's buffer again, and off the UART would go. Obviously, the CPU would be interrupted much less frequently. In fact, the overhead of handling a single line of data becomes

$$T_{buffered-transmit-64} = T_{syscall} + T_{int} + 64 \times T_{u \rightarrow u}$$

In the case of the receiver, however, you have to be more ingenious. Even if the UART can store incoming data in its own buffer, you can't just ask it to interrupt only when its buffer is full. If the UART has a 64-character buffer, the device driver wouldn't be interrupted until 64 bytes had arrived. And until it was interrupted, the driver wouldn't know that there was any data to pass along to the operating system (and ultimately to the application). What would happen? You would see a response from the system only after typing 64 characters. If your command could be typed with fewer than 64 characters, it would just sit in the UART's buffer. Not until the UART's buffer was full would the UART interrupt. Clearly, this won't work.

What you must do is periodically check the UART to see if data is present even if the UART's buffer is not full. The device driver asks the operating system to notify the driver every 1/20 of a second. (If you were to check less fre-

Table 3: Time to poll and check the UART.

| Variable | 8-MHz 80286 | 16-MHz 80386 |
|------------|-------------|--------------|
| T_{poll} | 285 μ s | 125 μ s |

Table 4: Overhead for polled transmit and receive operations (continuous operation at 9600 bps).

| Operation | CPU time consumed | |
|--------------|-------------------|--------------|
| | 8-MHz 80286 | 16-MHz 80386 |
| Transmitting | 14% | 12% |
| Receiving | 24% | 20% |

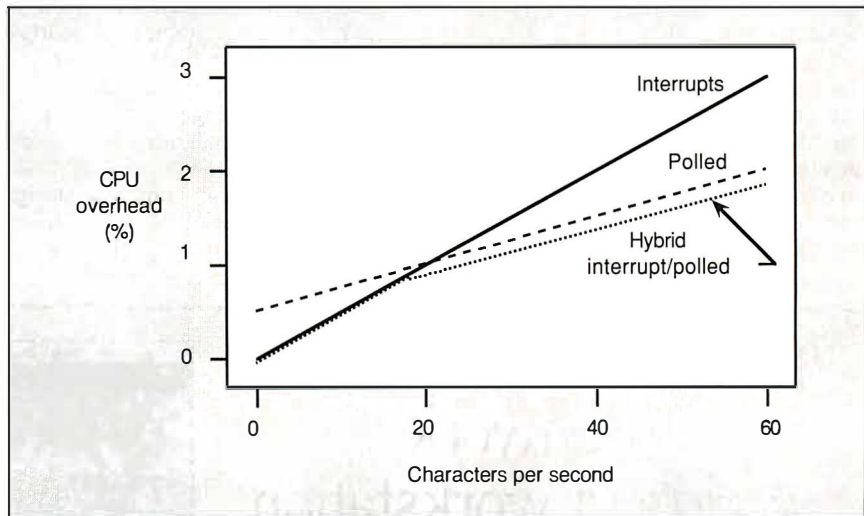

Figure 2: Comparison of device and driver performance for interrupts, polling, and hybrid interrupt/polling.

quently, the echoing of characters to the terminal wouldn't take place quickly enough, and the delay would become noticeable and distracting.)

When the driver is notified, it checks the UART and transfers whatever is in the UART's buffer into the driver's buffer. In this way, no character is left in the UART's buffer for more than 50 milliseconds. Thus, you reduce the worst-case number of interrupts (from 960 per second for a 9600-bps connection to 20 per second) and yet avoid problems of stale data in the UART's buffer.

But how do you analyze the overhead? Well, you need one more variable in the analysis: T_{poll} is the CPU time needed to check (poll) the UART's receiver buffer. Using this variable, the overhead of an idle (receiving) line is expressed as

$$T_{poll-receive-idle} = 20 \times T_{poll}$$

whereas the overhead of handling a saturated line for 1 second (running at 9600 bps with lines averaging 64 characters) is approximately

$$T_{poll-receive-max} = 15 \times T_{syscall} + 20 \times T_{poll} + 960 \times T_{u \rightarrow p}$$

In 1 second, 960 characters arrive, 20 polls occur, and fifteen 64-character lines are passed to the application.

Table 3 gives the value for T_{poll} and table 4 calculates the overhead for polled operation. Compare this table with table 2. Polling has cut the overhead roughly in half when running 9600-bps lines continuously.

Light Loads

But what about light loads? If the port is idle, the interrupt approach generates no

continued

load (since no interrupts are occurring). The polled approach, however, still generates 20 interrupts per second. Yet at higher rates, polling is better. What's the answer?

The solution is to put some additional intelligence into the communications interface. By changing the design of the device itself so that it uses interrupts at low rates and polling at higher rates, you can take advantage of both worlds.

One approach would be an interface that generated an interrupt only if one or more characters had been received but not read after 50 ms. At low traffic rates (below 20 cps), the overhead of this device would be the same as that of the interrupt-driven UART. At higher rates, it would be similar to that of the polled UART. The resulting performance would be the best of both worlds.

Figure 2 compares the performance of the three approaches: interrupts, polling, and hybrid interrupt/polling. Note that the hybrid approach is even better than polling at higher data rates, since device interrupts require less CPU time to handle than requesting (and receiving) scheduled clock interrupts.

Is There One Best Way?

Neither interrupts nor polling is always best. By closely examining the performance of each system, I have shown the strengths of each and, in the final step, developed a design to exploit each one. The result is a design for a serial-communications interface that has low overhead at low loads and an overhead that does not increase substantially at much higher loads.

The analysis does not have to stop here. Most of the better communications boards and device drivers have been designed after much more extensive analysis of the question of overhead. This analysis shows that additional performance can be gained (1) by migrating some of Unix's character processing to a CPU on the communications board itself, (2) by taking advantage of multiple UARTs on the same board to perform work on multiple ports at each interrupt, and (3) by processing packets of characters rather than individual characters whenever possible.

There are always important design issues in Unix serial communications that require careful analysis during the

design process. Assumptions such as "We'll use interrupts; all our other device drivers do" cannot lead to optimal design.

Think, and design the hardware and software together. Only in this way can you develop superior products. Rarely can a hardware engineer or a software engineer design an optimal device working alone. Separately, specialists can optimize a design only to their own goals. Together, they can optimize a design to maximize overall price/performance. The better designs are almost all a result of such collaboration. ■

ACKNOWLEDGMENT

The author would like to thank *Carolanne Reynolds* for assistance in preparing this manuscript.

George E. Pajari is president of Driver Design Labs, a Canadian company specializing in the design and development of custom Unix/Xenix device drivers for hardware manufacturers, OEMs, and sophisticated end users. He can be reached on Usenet as "ubc-vision!cd!!pajari" and on BIX c/o "editors."

PERFORMANCE BREAKTHROUGH!

Teamwork[®], world's #1 workstation CASE environment, available for your PS/2.

If you have PS/2 workstations, you're ready to move into high gear with workstation CASE.

Only **Teamwork** for **OS/2** improves your productivity with:

- ▶ Easy to learn, easy to use, intuitive graphic user interface
- ▶ Multi-tasking, multiwindows; Support for work groups
- ▶ Complete syntactical checking and balancing; Project management
- ▶ Fully integrated analysis, data modeling and design environment for

only \$4,995.

CADRE Cadre Technologies Inc.
 222 Richmond St.
 Providence, RI 02903

Teamwork is a registered trademark of Cadre Technologies Inc.
 PS/2 and OS/2 are trademarks of International Business Machines.

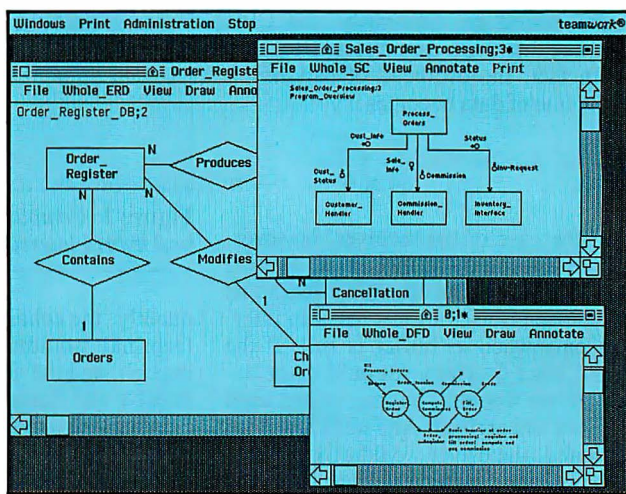

Just getting started with CASE? **Teamwork/PCSA** is a DOS-based Structured Analysis tool... compatible with Teamwork for OS/2... for **under \$1,000.**

Cadre gives you a fast start with hot-line support, maintenance services, excellent documentation, and numerous educational offerings. You'll even receive a money-back guarantee.

If you're using the PS/2, then you're ready for Teamwork. Anything else just won't meet your standards.

Call (401) 351-CASE

**NO
 SPEED
 LIMIT**

A Full House of C-Tool Products

C-Programmers

Nothing Up Our Sleeves Except, The Best, Most Complete C-Libraries East or West Of The Mississippi

There's only one sure bet in the C programming game: professional C-Tools from Essential Software. What's your pleasure?

- ✓ General Functions
- ✓ Graphics
- ✓ Communications
- ✓ Screen Generation/Input
- ✓ TSR's
- ✓ B-Tree
- ✓ Hands-On Informed Support

Essential has it all. No other company provides the range and depth of our C products. Whatever project you're working on or contemplating, there's an Essential product that will make the job easier, faster, leaner and more profitable. So why wait? Pick a card. Any card.....



C Utility Library contains over 400 functions. This library is the foundation of thousands of top notch programs in the corporate world and in the retail software marketplace

The Library includes pop-up menus, save/restore screens in 1/10 second, business graphics, string handling, code librarian, demo programs and complete 260-page documentation. Includes source.

Price w/source \$199



If you need more than the usual graphics routines, then **Essential Graphics** is your ace-in-the-hole. Highlights: Create bar and pie charts with a single function. World coordinates, viewports, font rotation including ten popular fonts. Supports, CGA, EGA, VGA, PGA, Herc and most other popular

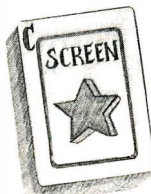

You design the screen, **ScreenStar** writes the code. Interactively paint data-entry forms, help screens, and pop-up windows. ScreenStar generates the C-source code; you compile, link and run.

Other features include screen capture program and complete overlapping window generation. Vertical and horizontal menu-scrolling functions.

Price \$99 w/source \$198

boards.

The graphics library is benchmarked as 40% faster than our nearest competitor. In graphics that can be the crucial edge you need.

Price \$299 w/source \$598

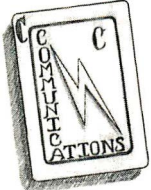

Essential Communications let's you play your serial card for all it's worth. Communicate with other PC's, mainframes, plotters, digitizers, modems or any device that utilizes the RS232 port.

Included in the library is a functional bulletin board system (BBS) and a terminal program. Interrupt driven transmit and receive up to 38.4 K Baud; XON/XOFF, XMODEM CRC, Hayes-compatible modem support, up to 8 ports.

Our combo package includes **BreakOut**, an interactive on-line data monitor.

Package Prices:

| | |
|---|-------|
| Communications Library w/source | \$185 |
| Communications Library w/BreakOut | \$250 |
| BreakOut | \$125 |
| Communications w/ /*resident_C*/ | \$299 |
| Communications w/ /*resident_C*/ and BreakOut | \$350 |

ScreenStar, B-TREE, /*resident_C*/, C-Utility Library, BreakOut, Essential Communications, Essential Graphics

are trademarks of **South Mountain Software Inc.**

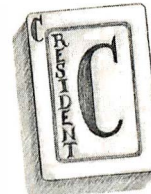
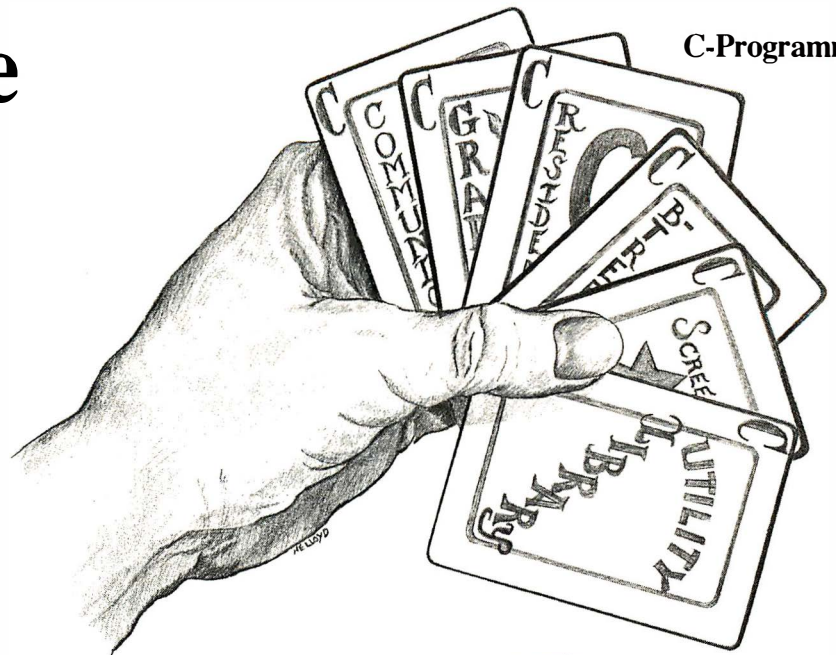

Now you see it, now you don't. **/*resident_C*/** lets you make any C program resident and write interrupt-service routines.

We've taken this highly misunderstood area of programming and brought it to a human level of understanding. Our manual and working demo's tell you exactly what we are doing every step of the way. Includes documentation of "undocumented" DOS calls.

Price \$99 w/source \$198

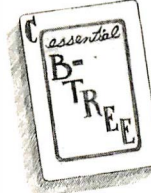

Essential B-TREE state-of-the-art indexed file handling. Fast, reliable, compact and easy to use. Contains all the features you expect. Easiest implementation among leading B-Tree products.

Price \$99 w/source \$198

Start Playing With A Full Deck

Don't start any C project with the cards stacked against you. Order the complete Essential Deck; everything you see on this page, including source code, for \$999. Call today and order the complete deck or just one card.

30-day money-back guarantee.
No royalties or run-time fees.

1-800-451-6174



Formerly Essential Software Inc.

South Mountain Software Inc.

South Orange Plaza
76 S. Orange Ave., Suite 3
South Orange, N.J., 07079

N.J. 201-762-6965

Fax 201-762-0118

Some Flavors of Unix

Unix System V

Unix operating system; source code only available

AT&T Information Systems
100 Southgate Pkwy.
Morristown, NJ 07960
(800) 247-1212

Inquiry 987.

AIX (Advanced Interactive Executive)

Unix for 80386 computers

IBM Corp.
113 Westchester Ave.
White Plains, NY 10605
(800) 447-4700

Inquiry 988.

A/UX

Unix System V for the Mac II

Apple Computer, Inc.
20525 Mariani Ave.
Cupertino, CA 95014
(408) 996-1010

Inquiry 989.

Domain/OS

Choice of three operating systems for Apollo Domain workstations: AT&T's Unix System V release 3, Berkeley 4.3 Unix, and Apollo's Aegis

Apollo Computer, Inc.
330 Billerica Rd.
Chelmsford, MA 01824
(508) 256-6600

Inquiry 990.

Enix System V

Unix System V version 3.2 for 80386 machines

Everex Systems, Inc.
48431 Milmont Dr.
Fremont, CA 94538
(415) 498-1111

Inquiry 991.

HP-UX

Unix for HP 9000 Series 300 systems

Hewlett-Packard Company
3000 Hanover St.
Palo Alto, CA 94304
(415) 857-1501

Inquiry 992.

MACH

Unix for multiprocessors and high-security systems (trusted systems); developed at Carnegie-Mellon University

MT XINU, Inc.
2560 Ninth St.
Berkeley, CA 94710
(415) 644-0146

Inquiry 993.

Merge 386

Hybrid Unix/DOS environment for 80386-based systems

Locus Computing Corp.
9800 La Cienega Blvd.
Inglewood, CA 90301
(213) 670-6500

Inquiry 994.

Microport 286

Unix System V.2 for 80286-based systems

Microport 386

Unix System V.3 for 80386-based systems

Microport Systems, Inc.
550 East Brokaw Rd.
San Jose, CA 95112
(408) 438-8649

Inquiry 995.

MINIX

Unix for the IBM PC, AT, and compatibles for teaching operating-system design;

written by Andrew Tanenbaum

Prentice-Hall, Inc.
Book Distribution Center
Route 59 at Brook Hill Dr.
West Nyack, NY 10995
(914) 358-8800

Inquiry 996.

Personal Mainframe

Unix system for personal computer-based engineering workstations

Opus Systems
20863 Stevens Creek Blvd., Building #400
Cupertino, CA 95014
(408) 446-2110

Inquiry 997.

QNX

Unix-like operating system

Quantum Software Systems, Ltd.
175 Terrence Matthews Crescent
Kanata South Business Park
Kanata, Ontario
Canada K2M 1W8
(613) 591-0931

Inquiry 998.

RTU

Real-time enhanced Unix

Concurrent Computer Corp.
Westford Facility
1 Technology Way
Westford, MA 01886
(800) 451-1825

Inquiry 999.

SunOS

Convergence of Unix System V and 4.3/4.2

BSD Unix for Sun workstations

Sun Microsystems, Inc.
2550 Garcia Ave.
Mountain View, CA 94043
(415) 960-1300

Inquiry 1000.

TI System V

Adapted from SCO Xenix V for TI Systems 1000, SP1000, 1100, 1200, and 1300

TI System V for System 1500

Adapted from Unix System V for TI System 1500

Texas Instruments, Inc.
P.O. Box 1444 MS 7722
Houston, TX 77251
(800) 847-2787

Inquiry 1001.

Ultrix

Unix for DEC VAX systems

Digital Equipment Corp.
146 Main St.
Maynard, MA 01754
(508) 493-7161

Inquiry 1002.

VENIX/386

Real-time Unix for 80386-based machines

VenturCom
215 First St.
Cambridge, MA 02142
(617) 661-1230

Inquiry 1003.

Xenix 286

Xenix for 80286-based machines

Intel Corp.
5200 Northeast Elam Young Pkwy.
Portland, OR 97124
(800) 538-3373

Inquiry 1004.

SCO Xenix 386

Xenix for 80386-based machines

SCO Xenix System V/386

Xenix industry standard for 80286- and

80386-based computers

The Santa Cruz Operation, Inc.
400 Encinal St.
P.O. Box 1900
Santa Cruz, CA 95061
(800) 626-8649
(408) 425-7222

Inquiry 1005.

386/ix

Xenix-compatible Unix for 80386-based

computers, based on Unix System V

Interactive Systems Corp.

2401 Colorado Ave.
Santa Monica, CA 90404
(800) 346-7111
(213) 453-8649

Inquiry 1006.

MS-DOS \$99

We call PolyAWK our "toolbox language" because it is a general-purpose language that can replace a host of specialized tools or programs. You will still use your standard language (C, Pascal, Assembler or other modular language) to develop applications, but you will write your own specialized development tools and programs with this versatile, simple and powerful language. Like thousands of others, you will soon find PolyAWK to be an indispensable part of your MS-DOS toolbox. If you don't have enough OS/2 development tools, now it's easy to write your own.

A True Implementation Under MS-DOS & OS/2

Bell Labs brought the world UNIX and C, and now professional programmers are discovering AWK. AWK was originally developed for UNIX by Alfred Aho, Richard Weinberger & Brian Kernighan of Bell Labs. Now PolyAWK gives MS-DOS & OS/2 programmers a true implementation of this valuable "new" programming tool. PolyAWK fully conforms to the AWK standard as defined by the original authors in their book, *The AWK Programming Language*.

A Pattern Matching Language

PolyAWK is a powerful pattern matching language for writing short programs to handle common text manipulation and data conversion tasks. A PolyAWK program consists of a sequence of patterns and actions that tell what to look for in the input data and what to do when it's found. PolyAWK searches a set of files for lines matched by any of the patterns. When a matching line is found, the corresponding action is performed. A pattern can select lines by boolean combinations of regular expressions and comparison operations on strings, numbers, fields, variables, and array elements; patterns may reference properties of the current input line or any other program variables. Actions may perform arbitrary processing on selected lines. The action language looks like C, but there are no declarations, and strings and numbers are built-in data types. You can have multiple input files and output files, regular expressions, user-defined functions, and run other programs.

Saves You Time & Effort

The most compelling reason to use PolyAWK is that you can literally accomplish in a few lines of code what may take pages in C, Pascal or Assembler. Programmers spend a lot of time

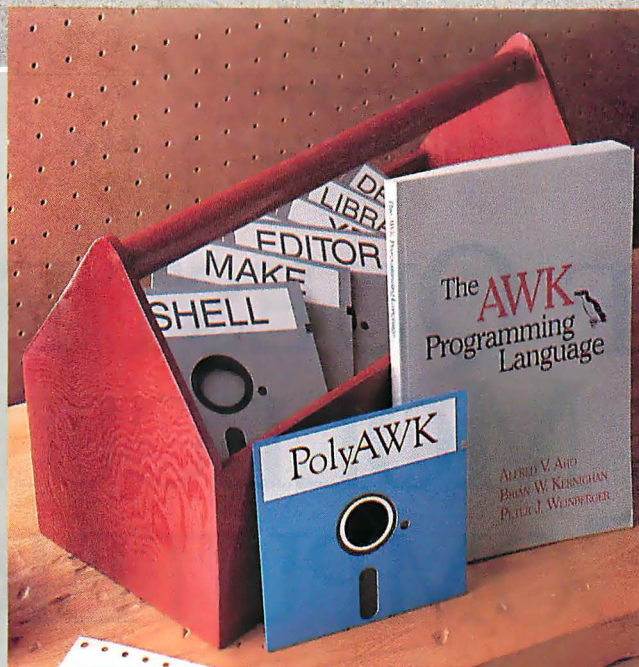

PolyAWK.[™] The Toolbox Language.[™] For C, Pascal, Assembly & BASIC Programmers

writing code to perform simple, mechanical data manipulation — changing the format of data, checking its validity, finding items with some property, adding up numbers and printing reports. It is time consuming to have to write a special-purpose program in a standard language like C or Pascal each time such a task comes up. With PolyAWK, you can handle such tasks with very short programs, often only one or two lines long. The brevity of expression and convenience of operations make PolyAWK valuable for prototyping even large-sized programs.

Very Concise Code

Where program development time is more important than run time, AWK is hard to beat. These AWK characteristics let you write short and concise programs:

- The implicit input loop and the pattern-action paradigm simplify and often entirely eliminate control flow.
- Field splitting parses the most common forms of input, while numbers and strings and the coercions between them handle the most common data types.
- Associative arrays use ordinary strings as the index in the array and offer an easy way to implement a single-key database.
- Regular expressions are a uniform notation for describing patterns of text.

OS/2 \$199

- Default initialization and the absence of declarations shorten programs.

Large Model & Math Support

PolyAWK is a large model implementation and can use all of available memory to run big programs or read files greater than 64K. PolyAWK also includes extensive support for math functions such as strings, integers, floating point numbers and transcendental functions (sin, log, etc.) for scientific applications. Conversion between these types is automatic and always optimized for speed without compromising accuracy.

PolyAWK Comes With The Book

When you order PolyAWK you receive a copy of *The AWK Programming Language* written by the authors of the original UNIX-based AWK. The book begins with a tutorial that shows how easy AWK is to use, followed by a comprehensive manual. Because

PolyAWK is a complete implementation of AWK as defined by the book's authors, you will use this book as the manual for PolyAWK.

PolyShell Bonus For MS-DOS!

PolyShell gives you 96 of the most useful UNIX commands and utilities under MS-DOS in less than 20K. You can still use MS-DOS commands at any time and exit or restart PolyShell without rebooting. MS-DOS programmers — discover what you have been missing! UNIX programmers — switch to MS-DOS painlessly! PolyShell and PolyAWK are each \$99 when ordered separately. Save \$50 by ordering the PolyShell + PolyAWK combination package for \$149 (MS-DOS only).

30-Day Money Back Guarantee

You can purchase PolyAWK and the book, *The AWK Programming Language*, for \$99 (MS-DOS) or \$199 (OS/2), or \$249 for both. If you already have the book, deduct \$14. The combination package includes only one book. Order PolyAWK (MS-DOS & OS/2) plus PolyShell (MS-DOS) for \$348.

To Order: 1-800-547-4000

Ask for Dept. BYT. Send Checks and P.O.s To: POLYTRON Corporation, 1700 NW 167th Place, Beaverton, OR 97006, (503) 645-1150 — FAX: (503) 645-4576, TELEX: 325800 POLYTRON. Call About Our OEM/VAR Strategic Alliance Program.

POLYTRON

High Quality Software Since 1982

THE QUEST FOR THE MOLECULAR COMPUTER

*Computer components are already microscopic.
How much smaller can they get?*

Mark A. Clarkson

In the past four decades, computers have shrunk from room-filling behemoths to fingernail-size wafers and have gone from fast to almost unbelievably fast. It seems reasonable to ask how much further this evolution can go. What is the lower limit on size? What is the upper limit on speed?

Scientists are working to design and build computing circuits that work at these limits—orders of magnitude smaller than current circuits and too fast to measure.

The quest for the molecular computer—a computer with components the size of molecules—is about raw power, pure and simple. As anyone who works with computers knows, the one thing you can always use is more speed. Complex simulations and graphics processing require massive computational power. Molecular circuits will be 100,000 times faster than the ones in the PC on your desk.

As the components shrink, so do the computers. As microprocessors have shown us, smallness can be a power all its own, bringing with it the ability to put computers into places that are far too small for today's devices. A computer with molecular gates and circuits might be too small to see—small enough to fit within a human cell. Much smaller than neurons, such computers might be hooked together in parallel, more densely and complexly than the brain.

In the book *Engines of Creation* (Doubleday, 1987), Stanford University scholar K. Eric Drexler explored the idea of artificial molecule-scale machines, including computers, but it is certainly not a new idea. In 1959, the late Nobel-laureate physicist Dr. Richard Feynman gave a talk entitled "There's Plenty of Room at the Bottom," in which he discussed "maneuvering things atom by atom" to build devices on a molecular scale. "It is not," he said, "an attempt to violate any laws; it is something . . . that can be done. It has not been done because we are too big."

After almost 30 years, we have now begun to direct the construction of new proteins, to view and manipulate individual atoms and molecules. Feynman's vision may finally be at

hand. If we could arrange things atom by atom, or at least molecule by molecule, then we could build computers that are very small, and very fast, indeed—so small and fast that I need to define some words to use in talking about them.

A millimeter is one-thousandth of a meter; a silicon chip, without its package, can be measured in millimeters. Smaller still is the micron (μ)—one-millionth of a meter. Individual transistors on that silicon chip are measured in microns. A nanometer (nm) is one-billionth of a meter; molecules are measured in nanometers.

Similarly, a microsecond is one-millionth of a second; a nanosecond (ns) is one-billionth of a second. Light travels the length of this page in a nanosecond. One-trillionth of a second is a picosecond (ps), the time it takes light to travel the width of the period at the end of this sentence. A femtosecond is one-thousandth of that.

A current, high-density silicon IC might pack 50,000 transistors into a square millimeter, with a spacing between components on the order of $1\ \mu$ to $2\ \mu$. Improved manufacturing technology and new materials could eventually reduce this by 90 percent, but current thinking says that semiconductors can't get any smaller than that.

As size decreases and density increases, components cannot shed heat as easily, and overheating becomes a problem. Reliable manufacture of objects so small becomes much more difficult. Additionally, at about $1/10\ \mu$, the space between individual components becomes so small that electrons begin to *tunnel*, jumping unpredictably from one place to another, thus creating spontaneous short circuits.

The dividing line between the microscopic and the molecular is $1\ \mu$. Below that, the difference is no longer merely a matter of scale, it is a matter of domain as well. At the microscopic level, electronics as we know it still functions. Below this level, we enter the realm of quantum physics, where electronics ceases to function; electricity no longer exists as a mass phenomenon, and electrons must be treated as quirky individuals. At this

continued

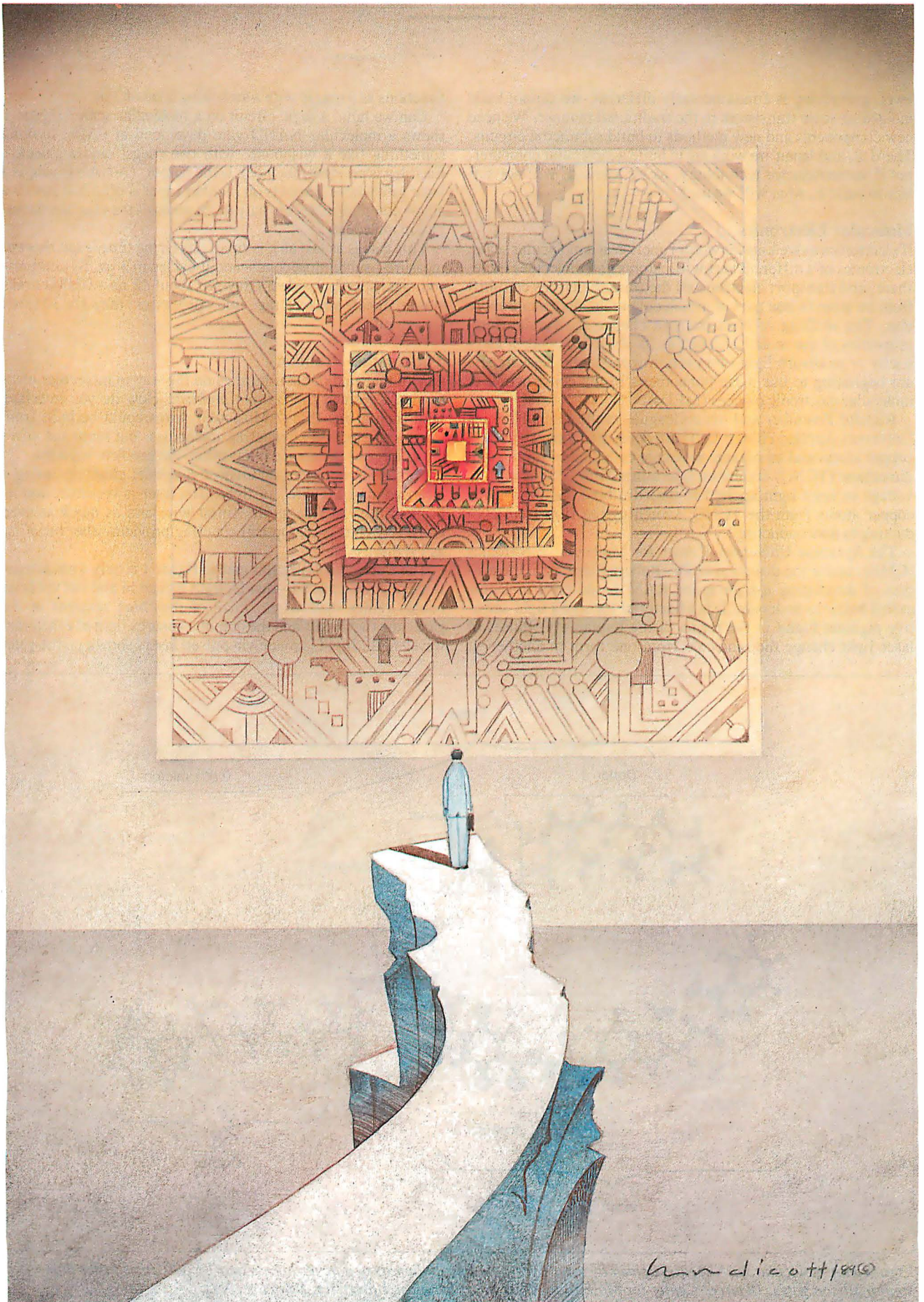

Endicott/1989

level, everything is fundamentally different; we cannot build molecular-scale transistors in the traditional manner. We need new components and new methods to build submicron circuits. The U.S. and Japan are working to build a molecular computer, but if semiconductor technology, as we know it, will not suffice to build it, what will we use?

Molecular Electronics

If electronics as we know it won't function at a molecular scale, electronics of a different sort will. Atoms and molecules trade, share, and transport electrons all the time. Electrons can shift from an atom in one part of a molecule to an atom somewhere else. The shifting of electrons can change the fundamental properties of the molecule, such as its ability to conduct electricity or to absorb light of a certain wavelength. Researchers are beginning to use these phenomena in the construction of molecular electronic devices (MEDs).

Richard Potember and his colleagues at the Johns Hopkins University Applied Physics Lab have developed a switch built of copper atoms and an organic molecule called tetracyanoquinodimethane (TCNQ) combined into a thin film. Pulses of high voltage or laser light applied to the film bind and unbind the copper atoms from the TCNQ, switching the film from conducting to nonconducting.

The Syracuse University Center for Molecular Electronics (CME), under the direction of Dr. Robert Birge, is in the process of developing a high-speed RAM based on a molecule called bacteriorhodopsin. It is a bacterial form of a light-sensitive pigment found in the retina of the human eye. Pulses of laser light change the molecule from one form to another. It

functions as a toggle with a switching time of 3 ps.

Can we build a logic circuit on a molecular scale? Figure 1 shows a molecular NAND gate developed at CME, looking something like a wishbone, with two "legs" and a "neck." Each leg is an input; the neck is the output. (A NAND gate is a logic gate whose output is on if either input is off.) The gate is a single complex molecule only 4 nm across—the size of a hemoglobin molecule.

This gate is as fast as it is small. Its firing time is too short to measure—subfemtosecond—and it cycles in 3 ps. By comparison, gate speeds inside a Cray are about 12 ns—10,000 times slower. Inside your average microprocessor, they are 20 times slower still.

The Contact Problem

One of the fundamental hurdles on the way to molecular electronics is termed the *contact problem*: How do you interface with such a tiny thing? Molecular wires could be built from strands of electron-conducting molecules, but since the wires are as large as the device in question, the problem remains.

Perhaps a more elegant answer is optical coupling: using a laser beam as a "wire" of light. The laser is versatile, and its beam can be as fine as the finest wire and as quick as even CME's NAND gate. Optical coupling provides other benefits, as I'll discuss later.

The electronic molecular gate in figure 1 is only 4 nm across. It is optically coupled—that is, data is read in and out via laser beams rather than wires. Each of the three sections of the gate—the two inputs and the output—absorbs light of a different wavelength. Input is made via pulsed lasers shown on the gate.

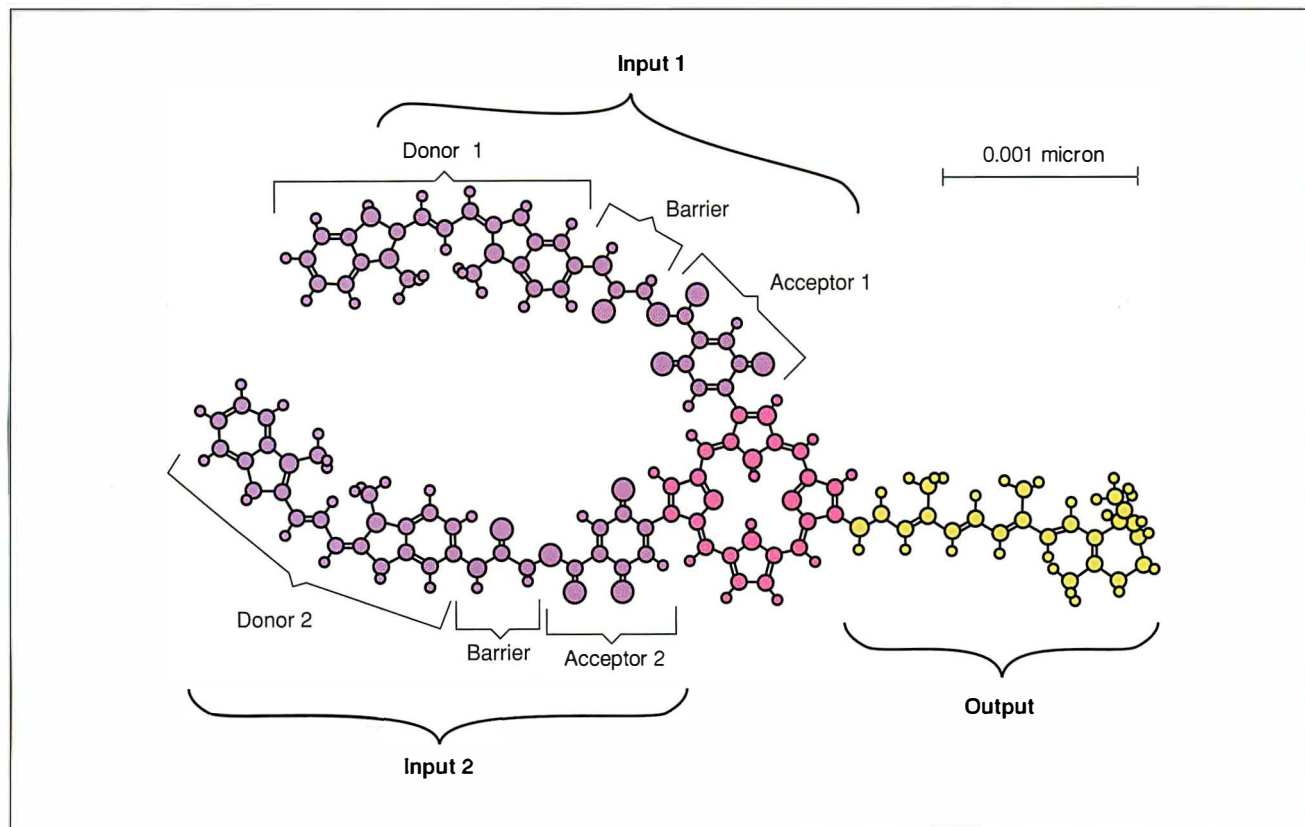

Figure 1: A molecular NAND gate, driven by laser light. It is four-billionths of a meter across and 10,000 times faster than similar silicon gates. (Source: Center for Molecular Electronics, Syracuse University, Syracuse, NY)

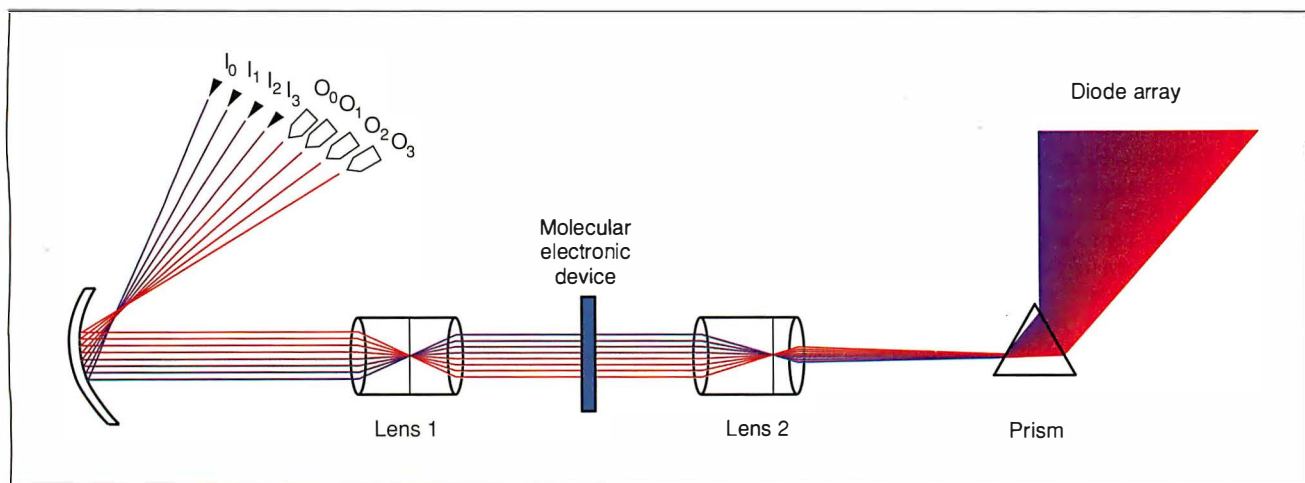

Figure 2: Eight frequencies of laser light (representing the four input and four output channels) are passed through the molecular electronic device, and the emerging light is read via the diode array (DA). Components in the MED can block the output frequencies of light or let them pass through. (Source: Center for Molecular Electronics, Syracuse University, Syracuse, NY)

Output is read via a third laser shown through the gate; if its light passes through, the output signal is on; otherwise, it is off.

Each input leg of the gate consists of an acceptor and a donor separated by a barrier. With no input applied to the gate, each donor has transferred an electron to its acceptor. The behavior of the output section is altered by the presence of these two extra electrons in its neighborhood. When an input is struck by laser light of the proper wavelength, the electron is transferred back from acceptor to donor. If both inputs fire, both electrons are transferred away from the output section simultaneously, making its environment unstable. As a result, the absorption band of the output (the wavelength of light that it absorbs) shifts into the range of the output laser, blocking its light.

The lasers need not be focused directly on an input or output; in fact, the entire gate is smaller than the beam. The address of the gate is defined optically with different wavelengths of light, rather than spatially with different wires. As a result, the gate can be placed anywhere within a given MED, and the individual inputs and outputs can be placed within the molecule however it is convenient.

Figure 2 shows an optically coupled 4-bit MED with four input and four output lasers. Each I/O channel is represented by a laser on a different wavelength. Input is provided by the four pulsed lasers (I_0 through I_3). Output is provided by the four continuous lasers (O_0 through O_3). The output is read by an array of light-sensitive diodes (DA). Lens 1 combines the different beams and spreads the resulting light over the entire MED. Lens 2 refocuses the exiting beam, and the prism splits it into its component parts again. The lasers affect only the I/O portions of the MED.

Probability and Proteins

Molecular gates dissipate little heat and can be packed much more densely than can silicon gates. They are, however, still vulnerable to manufacturing defects and to quantum phenomena, such as the unpredictability of individual electrons.

An obvious way to compensate is with simple redundancy: Use an ensemble of thousands of identical gates, operating in parallel as a single component. The output is averaged, filtering out statistical perturbations and component malfunctions. (In the arena of molecular electronics, the use of thousands of molecules in one device is called *bulk technology*.)

Optical coupling makes this parallel operation and ensemble averaging convenient. A laser can illuminate 1000 molecules as easily as one—more easily, in fact—and since our NAND gates block laser light when they fire, our ensemble of NAND gates would produce a measurable drop in output laser light, even if only 90 percent of the gates worked properly.

Starting with such small components gives us some elbow room: 100,000 molecular NAND gates would still fit comfortably within a square micron. Even so, some argue that the need for such large-scale redundancy eliminates the size advantage of molecular circuits over semiconductors.

Robert Birge doesn't think that's the point. In fact, he thinks lasers and ensemble processing may make the supercomputers of 10 years from now *bigger*. "Molecular electronics is not going to make a small computer," he says, "it's going to make a fast computer." Speed, he thinks, is a worthy goal in itself.

But not everyone is willing to give up on the molecular-scale computer, or *nanocomputer*. In a move of quantum jujitsu, Robert Bate of Texas Instruments has transformed electron tunneling from the problem into the solution. He is building a device in which the tunneling of electrons can be switched on and off. By harnessing quantum phenomena such as electron tunneling, Bate believes he can build molecular electronics that are more reliable and less "noisy" than semiconductors. (See the article "The Quantum Transistor" on page 275.) These electronics could also make possible a million-fold increase in component density, with a corresponding increase in speed.

Babbage Revisited

In 1833, Charles Babbage began work on an "analytical engine"—a mechanical digital computer, powered by steam and driven by rods and gears. He never completed it.

Now, 150 years later, Drexler is proposing a similar computer, but on a nanometer scale.

In what he terms "a really conservative argument," Drexler has avoided many of the sticky questions of quantum physics by designing a computer similar to Babbage's that would send signals by pushing and pulling on atom-wide rods of carbon.

Drexler believes that the highest-performing nanocomputers will use molecular electronics. The appeal of the mechanical nanocomputer, on the other hand, is that it is easier to design

continued

Rods and Knobs

The mechanical molecular computer designed by K. Eric Drexler uses logic circuits based on the movement of rods rather than electronics. The rods are studded with two types of knobs, called *gate knobs* and *probe knobs* (see figure A). The knobs are specially designed not to react with each other when they come into contact.

The rods intersect each other at right angles. A gate knob at an intersection will block a corresponding probe knob from being pushed through. In figure B1, the gate knob on rod *y* blocks the probe on rod *z*, preventing the probe from being pushed left. As a result, the knob on the output rod can move up. In figure B2, rod *z* is free to slide left, blocking the output rod.

To drive the gate, all the probe gates are drawn back (down or right), and then the input rods *x* and *y* are set in the desired on and off positions. Lastly, the rods with probe knobs are pushed. If no gate knobs block the intersections, the rods move. The new positions of the rods affect other rods in other gates in the circuit.

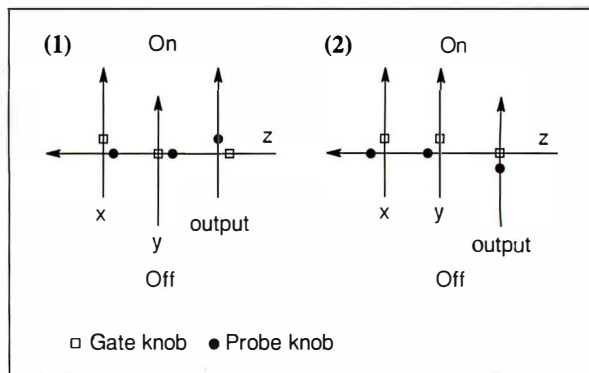

Figure B: (1) Schematic of a rod logic NAND gate. As long as the gate knob on either the *x* or *y* input blocks the intersection, the output rod is free to slide. (2) If *x* and *y* are both on, rod *z* is free to slide, blocking the output rod.

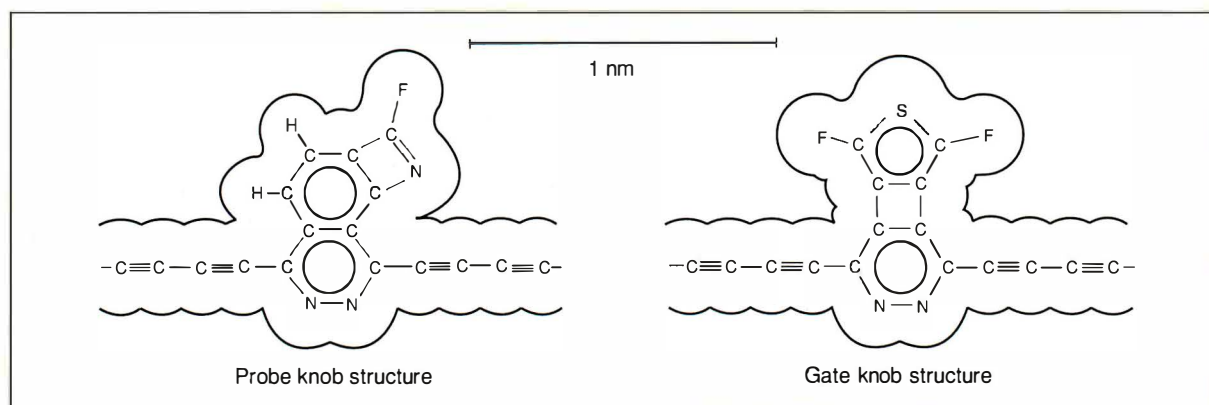

Figure A: The rods are atoms of carbon strung end-to-end. The knobs are specifically designed not to interact with each other. (Source: K. Eric Drexler, Foresight Institute, Palo Alto, CA)

and understand. Drexler sees it as a worst-case analysis of molecular computing: We will be able to do at least *this* well.

The rods in Drexler's nanocomputer would be chains of carbon atoms, joined single-file into strands one atom wide and a fraction of a micron long. The rods are studded with knobs, one every few nanometers, and fitted tightly together in an interlocking three-dimensional matrix. They slide back and forth in channels within a rigid framework, intersecting each other at right angles, like a fantastically complex puzzle. Where the rods meet, a knob on one can block the intersection, keeping the corresponding knob on another rod from being pulled through. (See the text box "Rods and Knobs" above.)

Drexler estimates that a rod-logic nanocomputer that is functionally equivalent to a simple microprocessor would be less than 100 nm across. While it would be orders of magnitude slower than a comparable molecular electronic device, it would still be faster than a Cray. Though the rods would move at less than 10 meters per second, they would need to move only a few nanometers, yielding subnanosecond gate speeds.

For high-speed RAM, Drexler suggests a block of mechanical memory cells with sliding rods and tabs that encode data by

clamping some rods and leaving others free to move. 64K bytes of this RAM would be about 70 nm on a side.

For mass storage, the computers might use long polyethylene molecules as tape, storing data in carbon atoms. This kind of tape would be over 100 times denser than the high-speed mechanical RAM. A 64K-byte device, including tape, reel, drive, and read/write apparatus, would measure about 10 nm across.

For the most part, Drexler's solution to the contact problem is to have no contact. Rather than using nanocomputers as minuscule PCs and interacting with them directly via keyboard and screen, he prefers to give them tasks better suited to their size. He sees his nanocomputers as autonomous agents that could fit inside human cells to supervise machinery repairing damage and disease or that could direct molecular assemblers in the building of more nanocomputers.

By avoiding electronics, Drexler's computers avoid the worst of the uncertainties associated with electrons. Like their molecular counterparts, these computers would dissipate little heat, and their components could be packed together quite densely. Drexler thinks that the technologies that give us nanocomputers will eliminate manufacturing defects almost completely.

Building the Nanocomputer

Much, if not most, of the work of building nanocomputers today is being done by chemists, which might seem strange until you realize that chemists have been building molecules on the nanometer scale for decades. Building molecules is a chemist's business. Chemistry and its close cousin genetic engineering both provide paths to the construction of the nanocomputer.

Molecular gates could be brewed in test tubes through chemical reactions or built up, a few molecules at a time, into thin films. Genetic-engineering techniques allow very complex molecules to be built one fragment at a time. These methods are used to build today's simple MEDs, such as NAND gates.

Genetic engineers can produce custom proteins that bind together selected molecules. These "designer" proteins might build tomorrow's MEDs, reading instructions and assembling the component parts much as the ribosomes in cells read genetic code and assemble proteins themselves. Molecular circuits could thus self-assemble out of solutions in test tubes.

In addition to being fantastically inexpensive, this method would be almost perfectly reliable because the selective binding of individual molecules would assure proper assembly. Many researchers believe that full-scale manufacturing of molecular circuits will require such biological systems.

Another route to the nanocomputer is direct manipulation. A device known as the Scanning Tunneling Electron Microscope (STEM) uses electron tunneling to produce images of individual atoms. In addition, by regulating the current in a needle held a few nanometers above a surface, scientists can sometimes grab individual molecules and atoms and then move them or break them apart. Control is still poor, but it is improving. In time, we might handle molecules like Tinkertoys, placing them together to make tiny circuits and wires or rods and gears.

STEM technology, or something like it, might also form the basis for a data-storage system. Bits could be represented by altered patches of atoms on the surface of the storage medium. If a bit were a patch 10 atoms on a side, a square centimeter would hold 100 trillion bytes. Every book ever written would fit in a space 20 centimeters square.

If It Were to Happen

If we are to build molecular computers, molecular gates and switches will eventually have to be combined into complex circuits. Little work is currently being done to this end—the gates themselves are usually far from reliable. No one is presently working to build a mechanical computer such as Drexler's. The molecular devices described in this article are all still basic research; it may be 10 or 15 years before we see products based on molecular electronics appearing on the market. In the meantime, through more conventional means, computers will continue to get smaller and faster.

Microprocessors have changed our lives. My \$30 wristwatch has a tiny chip that tells time, does math, and keeps my phone book and appointment calendar. The molecular equivalent of an IBM PC, meeting Drexler's worst-case standards for size, would fit by the thousands of billions into a teaspoon.

Molecular computers coupled with light-emitting dyes could form displays as good as real life. With sufficiently small parts, we could model the human brain, neuron by neuron. And if the submicroscopic computer continues to elude us, we will still have an increase in power and speed of three or four orders of magnitude by using molecular computing technology. ■

Mark A. Clarkson is a freelance writer living in Wichita, Kansas. He has been a computer consultant and analyst for eight years. He can be reached on BIX c/o "editors."

Want to save Time, Money,
& Headaches?



GET SUPERSOFT'S
SERVICE DIAGNOSTICS

All the software, alignment diskettes, parallel/serial wrap-around plugs, ROM POSTs and extensive, professional documentation to provide the most comprehensive testing available for IBM PCs, XTs, ATs and *all compatibles* under DOS or Stand Alone. No other diagnostics offers such in-depth testing on as many different types of equipment by isolating problems to the board and chip level.

NEW: SuperSoft's **ROM POST** performs the most advanced **Power-on-Self-Test** available for system boards that are compatible with the IBM ROM BIOS. It works even in circumstances when the Service Diagnostics diskette cannot be loaded.

NEW: 386 diagnostics for hybrids and **PS/2s!**

For over nine years, major manufacturers have been relying on SuperSoft's diagnostics software to help them and their customers repair microcomputers. End users have been relying on SuperSoft's Diagnostics II for the most thorough hardware error isolation available. Now versions of Service Diagnostics are available to save everyone (including every serious repair technician) time, money, and headaches in fixing their computers, even non-IBM equipment.

| | |
|--|--|
| All CPUs & Numeric Co-processors | All Color Graphics & Monochrome Monitors |
| System Expansion & Extended Memory | Parallel & Serial Ports |
| Floppy, Fixed & Non-standard Disk Drives | Mono, CGA, Hercules & EGA Adapters |
| Standard & Non-standard Printers | All Keyboards & the 8042 Controller |
| System Board: DMA, Timers, Interrupt, Real-time Clock & CMOS config. RAM | |

Join the ranks of XEROX, NCR, CDC, SONY, PRIME, ... who have bundled SuperSoft's diagnostics with their microcomputers at no risk because of our 30 day money back guarantee.

| | |
|---|--------------|
| Service Diagnostics for PC, PC/XT, and compatibles only..... | \$169 |
| Alignment Diskette for PC, PC/XT and compatibles (48 tpi drives)..... | \$ 50 |
| Wrap-around Plug for PC, PC/XT and compatibles (parallel and serial)..... | \$ 30 |
| Service Diagnostics for AT and compatibles only..... | \$169 |
| Alignment Diskette for AT and compatibles (96 tpi drives)..... | \$ 50 |
| Wrap-around Plug for AT (serial)..... | \$ 15 |
| ROM POST for PC, PC/XT and compatibles only..... | \$245 |
| ROM POST for AT and compatibles only..... | \$245 |
| Service Diagnostics: The KIT (Includes all of the above—save \$502)..... | \$495 |
| Service Diagnostics for 386 or V2, V30, or Harris, etc. (please specify)..... | \$195 |
| Diagnostics II is the solution to the service problems of users of all CP/M-80, CP/M-86 and MS-DOS computers..... | \$125 |
| ROM POST for PS/2 and compatibles only..... | \$245 |
| Alignment Diskette for PS/2 and compatibles (3.5 inch)..... | \$ 50 |

To order, call 800-678-3600 or 408-745-0234
FAX 408-745-0231, or write SuperSoft.

your microcomputer repair solution

SuperSoft

FIRST IN SOFTWARE TECHNOLOGY P.O. Box 611328, San Jose, CA 95161-1328 (408) 745-0234 Telex 270385

SUPERSOFT is a registered trademark of SuperSoft, Inc.; CDC of Control Data Corp.; IBM PC, AT & XT of International Business Machines Corp.; MS-DOS of MicroSoft Corp.; NEC of NEC Information Systems, Inc.; PRIME of PRIME INC.; Sony of Sony Corp.



**VOTED #1 BEST OF
UNIX COMMUNICATIONS SOFTWARE**

ONE COMMUNICATIONS PROGRAM THAT MAKES ALL OF OUR INCOMPATIBLE COMPUTER SYSTEMS COMPATIBLE?

I CALL THAT UNLIKELY.

They call it TERM.

TERM runs identically under DOS, UNIX, XENIX, VMS, BTOS and MAC?

TERM is keystroke-for-keystroke compatible across all of our different computer systems and offers features like automatically restartable file transfers, data compression and CRC error detection.

But, can it be customized?

TERM's built-in script language is so sophisticated that it allows exact solutions to be tailored to our specific needs. In fact, there are over 25 pre-built scripts provided for solving problems like unattended file transfers, remote system polling, and error logging. TERM script allows building customized menus, data entry screens and pop-up windows designed for your unique applications.

And it talks to non-TERM systems?

Fluently. TERM comes with nine protocols and thirteen terminal emulations... that's enough to communicate with a wide variety of different systems.

DEC Terminal Emulation?

Wait till you see it. TERM's VT220 emulator meets the needs of all of our divisions by providing exact VT220 and VT102 emulation on all terminals. We've got full graphics character support even under Unix...not to mention Televideo, SCO color console and the other emulations.

Where did you find it?

I called: 801-268-3088

Circle 308 on Reader Service Card

All orders shipped 2nd Day Air

TERM. Powerful Communications.

| Features: | |
|--|--|
| ✓ Automatically restartable file transfers | ✓ Remote PC execution |
| ✓ State-of-the-art Lempel-Ziv-Welch data compression | ✓ Powerful script language for customized applications |
| ✓ Exact VT220, VT102, and VT100 Emulation on ALL systems | ✓ Wildcard file send/receive capability |
| ✓ Fully remappable keypad support | ✓ Auto-login, dial/redial modem control |
| ✓ Full color support | ✓ Unlimited autodial directory |
| ✓ 38.4K file transfers | ✓ Performs unattended file transfers |
| ✓ KERMIT Protocol for mainframes | ✓ Remote maintenance capability |
| ✓ XMODEM and YMODEM Protocols for bulletin boards | ✓ Online User's Manual for instant help |
| | ✓ Electronic mail/TELEX/FAX |
| | ✓ Easylink/MCI Gateway |

TERM is available now on Altos, Apple Macintosh, Aris/Arise, AT&T, British Telecom, Bull, Burroughs, CCI, Celerity, Convergent Technologies, Counterpoint Systems, Cubix, DEC VAX, Fortune, Gould, Harris, Heurikon, Hewlett Packard, Honeywell, IBM, ICL, ICON, IMP, Integrated Solutions, Intel, Jarogate, Lanier, Masscomp, Momentum, Motorola, NCR Tower, Nixdorf Targon, Northern Telecom, Plexus, Prime, Pyramid, Ridge Computer, Sequent, Sigma Designs, Sun Workstation, Tandy, Unisys, Victor, Wang PC, Zenith and Zilog. Find out how easy it is to get your VMS, UNIX, XENIX and MSDOS machines all together.

TERM

COMMUNICATIONS SOFTWARE

Call or write for complete information



5284 South 320 West, Suite C134 Salt Lake City, Utah 84107 (801) 268-3088

THE QUANTUM TRANSISTOR

The rules of semiconductor physics are dramatically different when you are working at the level of quantum mechanics

Mark Reed

Until the 1950s, vacuum tubes were the key ingredient of electronic systems. The discovery of the transistor effect by Bardeen, Brattain, and Shockley was the culmination of a technology based in atomic physics and material science.

However, the true impact of semiconductor technology was not felt until the IC came into widespread use.

We now stand on the threshold of a new technology for electronic components, one that promises device densities 100 times greater and switching speeds 1000 times faster than what is currently possible. This technology is based on quantum effects, the very nature of matter and energy itself.

As George Heilmeyer, chief technical officer of Texas Instruments, has said, "Comparing quantum-effect devices with today's semiconductors is like comparing semiconductors with vacuum tubes." (See "TI's Prototype Transistor Takes a Quantum Leap," Microbytes, March BYTE.)

[Editor's note: This article contains terms that will be unfamiliar to those with little background in physics. These terms are explained in the glossary on page 280].

Scaling Down

The IC was the revolutionary enabler for relatively compact, efficient, and inexpensive digital computers. The

IC generation was followed by a long period of evolutionary progress. Much of this progress was due to downscaling.

In their seminal paper on the subject, Robert Dennard and coworkers at IBM proposed a scaling concept for silicon MOS-FETs (metal-oxide-semiconductor field effect transistors) that is still valid today. The principle of scaling is to reduce all the dimensions of the device by a constant factor while reducing all applied voltages accordingly to keep the potential gradients the same as in the unscaled device.

This evolutionary concept has produced an exponential decrease in minimum feature sizes with concurrent decreases in power, cost, and delay times. The exponential growth of the worldwide electronics market, especially in computer technology, is largely due to this progress.

Engineers and scientists have always known that the downscaling process could not continue indefinitely. Pallab Chatterjee and his colleagues at Texas Instruments had previously placed a diminishing-returns limit of 0.5 micron on ICs. More recent analysis indicates that the limit is more like 0.3 micron. ICs less than 0.1 micron are unlikely because electrons are capable of *tunneling* through the thin (less than 40 angstroms) silicon dioxide *gate dielectric*. The implication is that traditional semi-

continued

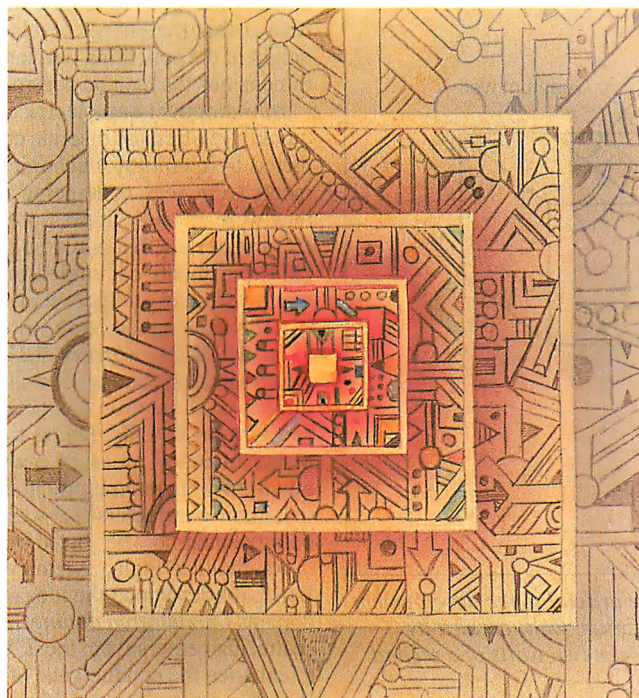

conductor technology will reach its limits in the mid to late 1990s.

What basic physical phenomena are reasonable candidates for a post-VLSI revolution? Molecular electronics (see "The Quest for the Molecular Computer" by Mark A. Clarkson on page 268), hybrid biological-electronic devices with nontrivial architectures, superconducting electronics, and all-optical devices make up the list. However, the outstanding candidate, both in promise and demonstrated results, is quantum effects in semiconductors.

Nanoregions

Quantum effects occur in any system when the wave nature of the particles of the system becomes important. In semiconductors, whenever conditions allow, the wave nature of electrons and holes becomes important. This generally happens when we try to confine these particles to regions smaller in dimension than their quantum mechanical wavelength.

In free space, the quantum mechanical wavelength of an electron is called the de Broglie wavelength and is dependent on the energy of the electron. This is the so-called wave-particle duality: Under the right conditions, particles clearly exhibit a wave nature. Likewise, electromagnetic waves (such as visible light) have an associated particle-like nature (photons). An idea associated with this is that a particle cannot be confined inside a dimension less than its wavelength. In other words, the exact location of the particle is uncertain (Heisenberg's uncertainty principle).

The world in which these effects are dominant is on the scale of atoms and molecules, so we cannot see, touch, or taste these effects. To observe them, we must either construct special experiments that make these effects dominant over all others on the macroscopic scale or reduce our experiments to the microscopic scale (called the *nanoscale*, based on the nanometer, which is a billionth of a meter). We have called the possible next generation of electronic devices in this regime *nanoelectronics*.

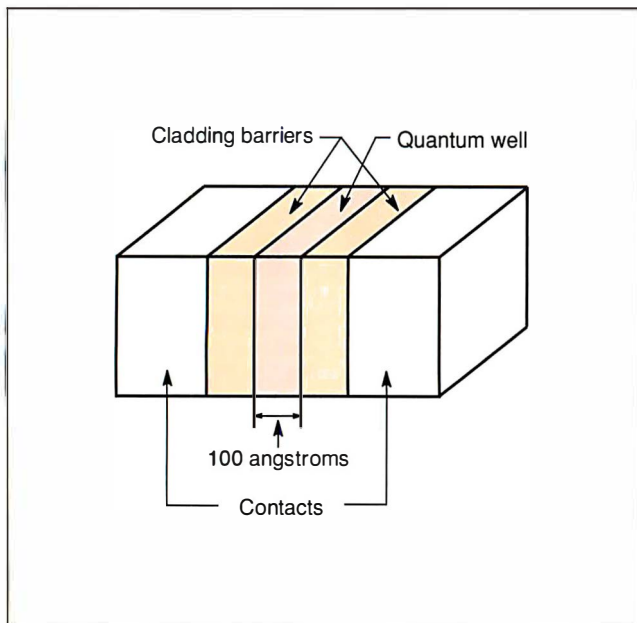

Figure 1: The underlying principle crucial to the development of the quantum transistor is the quantum well, created by sandwiching an ultrathin film between two walls of a second semiconductor material.

It appears
that traditional semiconductor
technology will reach its limits
in the mid to late 1990s.

Quantum Wells

In the late 1960s, Leo Esaki and Leroy Chang at IBM and Nick Holonyak at the University of Illinois began investigating the properties of electrons confined in *quantum wells*, semiconductor films only a hundred or so angstroms thick sandwiched between high confining walls made of a second semiconductor material (see figure 1). As I mentioned earlier, quantum effects become important when the characteristic wavelength of electrons is about the same size as the confinement region. For conduction electrons in semiconductors, this corresponding distance is called the Bloch wavelength (which can be an order of magnitude larger than the de Broglie wavelength for the same energy); for silicon at room temperature, it is about 0.01 micrometer (10 nanometers or 100 angstroms).

During this time, researchers John Arthur and Al Cho at Bell Labs were working on ultrathin-film crystal growth techniques that could butt two different crystals together in a commensurate fashion; that is, a heterojunction. This work was mostly with gallium arsenide (GaAs) and related III-V compound semiconductors, by molecular beam epitaxy (MBE).

Esaki and Holonyak realized that thin-film technology could be used to create quantum wells. Because the confining region is about the same size as the electron and hole wavelength, it is the solid-state analogy of an atom; the electrons in the well occupy a ladder of discrete, well-defined energetic values (subbands) analogous to atomic orbitals. The intriguing difference here is that the energy levels of the wells are sensitive to the height of the confining barriers and to the thickness of the well, dimensions that can be controlled.

Initial optical and electrical experiments on quantum wells quickly verified the discrete energy-ladder structure that is predicted by quantum mechanics. Though the electrical experiments were very convincing from a basic physics standpoint, they were not very impressive as devices, due to the poor quality of materials that could be produced at that time (the electrical experiments demanded material perfection). So, research was diverted to another, seemingly more fruitful, area, that of two-dimensional electron systems.

In the 1960s, workers at IBM verified that the electrons in the conducting channel of a silicon MOSFET constituted a two-dimensional electron gas (2DEG). This stimulated important research on 2DEGs, laying the groundwork for later developments in many areas of quantized systems. The developing quantum-well technology found an ideal application here in that many parameters that were fixed in the silicon 2DEG technology could now be varied by MBE.

Raymond Dingle, Arthur Gossard, and Horst Störmer of Bell Labs developed the idea of spatial modulation of electronic dopants (*modulation doping*), which thereby removes annoying scattering centers from the 2DEG conducting layer. The ability to enhance the conductance of a quantum well or accumulation layer by doping the neighboring higher band-gap layer is the

major innovation in this development.

Though the nature of the quantized states is important in the 2DEGs, these devices are distinct from quantum devices because the electron does not travel through the system "coherently." Coherent transport means that the wave nature of the electron coming into the system has some, if not all, of the original wave character of the electron preserved when it exits the system. In conventional transistors and the 2DEG devices, the electron has bounced off so many things by the time it gets across the device that the memory of the original wave is unrecognizably scrambled; thus, the electronic transport through the device is classical, not quantum, mechanical.

Resonant Tunneling Diodes

The first real quantum device was proposed and demonstrated by Chang, Esaki, and Raymond Tsu at IBM. The device is called a *resonant tunneling diode* and is shown in figure 2. The center of the device is a quantum well, with a spectrum of energy levels determined by the growth parameters. The wavelength of the confined electrons is about the size of the quantum well. If there were no other extenuating circumstances, electrons dropped into the well would sit there occupying those different energy levels. However, we have modified the situation by making the cladding barriers very thin, about the size of an electron wavelength.

Now, remember that the uncertainty principle states that the electron cannot be confined to a dimension less than its wavelength; thus, there exists some finite probability that the electron dropped inside the well might suddenly appear outside the well. This is the phenomenon of quantum-mechanical tunneling and has no classical-mechanical equivalent. It would be like throwing a baseball at a solid wall and having it pop out the other side. The dimensions at which this actually happens are typically about 50 angstroms, so we do not see this sort of phenomenon occur in the macroscopic world; the thicker the barrier, the less probability of the baseball tunneling through the wall. The probability may be very, very small, but it is *never* zero; the baseball actually has a finite probability of popping out the other side. True, it is much more probable that the universe will end first before we see the baseball on the other side of the wall.

Now, if an electron is thrown against the barrier wall of the resonant tunneling structure, it has a finite probability of either tunneling through or bouncing off. In more exact terms, it can tunnel through because the Bloch-wave functions of conduction-band electrons can have a finite amplitude in the *forbidden gap* of a semiconductor. The probability is tremendously enhanced when the energy (i.e., the wavelength) of the input electron matches that of the quantum well. When this resonant energy is reached, the tunneling probability is enhanced. (This is similar to the resonating effect provided by the reflecting mirrors in the cavity of a laser.)

In a resonant tunneling diode, we cannot control the electron energy, but we do have control over the potential difference applied across the device (see figure 2). We can bring the state of the quantum well into resonance with the electrons that are available at the point of injection; these can then tunnel through the double barrier formed by the cladding of the single quantum well. The crucial idea is that resonance (and thereby, high current) is achieved only when the quantum level lines up with the contact when a voltage is applied. If the quantum-well state is *not* in resonance, then the tunneling current is low.

This gives rise to a nonlinear current-voltage characteristic with peaks occurring when the quantum well reaches a reso-

continued

Compact Disk Products, Inc. CD-ROM/WORM

ALL PRODUCTS, LOWEST PRICES, EXPERT ADVICE

INTRODUCTORY OFFERS

- Hitachi 1503S or 3500S CD-ROM Drive with your choice of:
- NEW Programmer's Reference Library (Microsoft) . . . \$995
 - McGraw Hill Science and Technical Reference Set . . . \$920
 - Grolier Electronic Encyclopedia . . . \$995
 - Microsoft Bookshelf or PC-SIG Library (Add \$200) . . . \$895

SELECT CD-ROM SOFTWARE

- Oxford English Dictionary **NEW** \$945
- Comstock Stock Photography On CD . . . **NEW** \$445
- Educop Public Domain/Shareware for the Mac . . . **NEW** \$179
- The New Grolier Electronic Encyclopedia . . . \$399
- McGraw Hill or Bookshelf (Add \$25 for McGraw) . . . \$269
- The Bible Library \$495
- Kirk-Othmer Encyclopedia of Chemical Technology . . . \$845
- Registry of Mass Spectral Data \$2655
- Geovision U.S. Atlas and Mapmaker \$795

TOLL FREE ORDER LINE • 800-MEGABYTE (634-2298)

CD-ROM and WORM DRIVES

- Hitachi 1503S External CD-ROM Drive with Audio \$729
- 1503S with Digital Audio Output and CD-Capture . . . \$1229
- Hitachi 3500S Internal 1/2 Height CD-ROM Drive w/Audio . . \$719
- NEC Intersect CD-ROM Drives for the Apple/Mac CALL
- Maxtor 800 MB WORM Drive \$3899
- Portable 286 with CD-ROM Drive and Hard Disk CALL

CD-Play (\$89) Pop-up utility that permits user to play all audio CDs on Hitachi and compatible drives. Output to headphones or amplifier.

CD-AudioFile (\$149) Automatically creates database records of all your audio CDs. Allows you to store a preferred play sequence for each disk. Automatic recognition of CDs. Creates DBase compatible records.

CDP Consulting Services Now Available

CDP
Compact Disk Products
223 E. 85th St.
New York, NY 10028
Tel. 212-737-8400
Fax 212-737-8299
Compuserve 75530214

INTERNATIONAL ORDERS A SPECIALTY

International Agents:
United Kingdom
CDROM - New Menor Farm
Winterslow Near Salisbury
WILTS SP5 1SE
Tel. 0980-862890

Australia
Kewtel
145 Cotham Road
Kew, Victoria 3101
Tel. 03-8177-5933

Australia
Light Years Ahead
PO Box 561
Werrington, NSW 2078
Tel. 02-477-6666

Complete 386 Compiler Package for \$895

SVS FORTRAN-386

- Runs in 32-bit Protected Mode
- Accesses all Available Memory
- Supports VAX and IBM Extensions
- Supports the Intel 287/387 and
Wetec 1167/3167 Co-processors
- Applications run
up to four times
faster than those
created with other
compilers
- Compiles at High
Speed

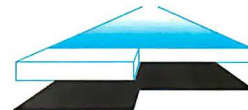

Package Includes:

- SVS FORTRAN Compiler
- LINK-REX Linker
- 100% Royalty Free License on
Distributed Software
- DOS Extender
- DOS Support
Library
- Librarian
- Debugger
- Technical Support

"The SVS compiling and linking is extremely fast, and the compiler produces nicely compact code." - *Micro/Systems Journal*

"The LOADS module in DOE-2 is about 14,000 lines of code. I used SVS FORTRAN-386 since it was the only compiler that would swallow the source code (VAX extensions)." - *Programmer's Journal*

Software Conversion Services are also available for converting FORTRAN mainframe source code to the 80386. This service includes conversion, code optimization, user I/O, and more. Call SAIC for more information.

SAIC
Science Applications
International Corporation
5150 El Camino Real, Suite C-31
Los Altos, California 94022

PRICES:
SVS FORTRAN-386.....\$895
SVS PASCAL-386.....\$895
Scitech Scientific Library.....\$325
Scitech Plotting Library.....\$325
Maintainability Analysis Tool....\$895

For More Information Call: 1-800-346-5159 In CA Call: (415) 960-5931

THE QUANTUM TRANSISTOR

**Protects
while you
type!**

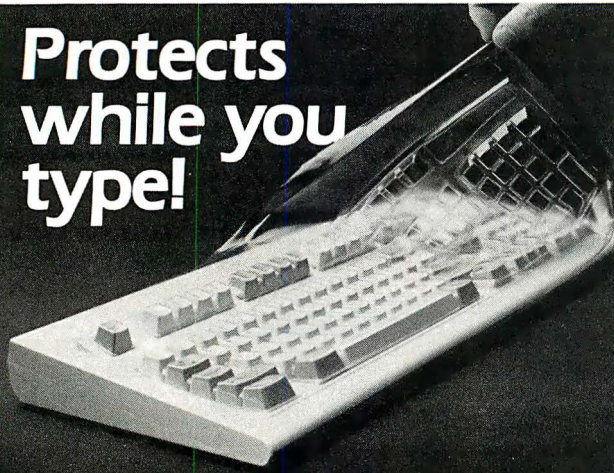

- Remains In Place while you use your computer.
- Avoids Costly Repairs. Protects delicate electronics from dust, spills, smoke, ashes, staples.
- Soft, Flexible, retains normal keyboard feel.
- Washable, Durable High-Tech Polymer lasts years.
- Hundreds of Models. SafeSkin is available for most PCs, laptops, workstations and clone keyboards.
- Office • Home • Factory • Classroom • Laboratory

List Price \$29.95. Please call or write for free color brochure. Dealer inquiries encouraged.

SafeSkin™
Keyboard Protector

Merritt Computer Products, Inc./4561 S. Westmoreland
Dallas, Texas 75237/(214) 339-0753 • Fax (214) 339-1313
In Canada call 1-800-663-1061

**Microcomputer News
On-Line**

In this fast paced industry, can you afford to wait a week or a month for information that may affect you today?

MicroBYTES Daily is an electronic news service covering the latest developments in the microcomputer industry. If it concerns MS DOS machines, Macintosh, Unix workstations, Amigas, Atari STs, peripherals, networks or software, you will find it in MicroBYTES.

Fast and Easy

Read the items as they break or use the powerful search command to quickly locate your information. Best of all you can download the text and print it or use it in your favorite word processor.

Whether you are a developer, marketer, or researcher, you need reliable information and you can count on MicroBYTES. Backed by the combined resources of BYTE Magazine, BYTEweek, and BIX, MicroBYTES gives you access to our world-wide network of reporters and the integrity and experience of our editorial staff.

In your position as a leader in new technology, you cannot afford to be just one of the crowd. Get ahead with MicroBYTES.

Call now and subscribe today.



One Phoenix Mill Lane, Peterborough, NH 03458
1-800-227-2983 In NH (603) 924-7681

nant condition (see the right side of figure 2). (A similar structure, called the *tunnel diode*, has a tunneling barrier formed by a macroscopic depletion layer between n-type and p-type regions. However, other than the use of tunneling, there is no similarity between the two devices; the resonant tunneling diode utilizes quantum confinement, which is controlled by the band-gap engineer.)

The coherency of the electron Bloch wave as it travels through the structure is important. In structures like the resonant tunneling diode, the quantum wells have dimensions that are typically less than the coherence length of the Bloch wave involved. The structure then "resonates" in response to the constructive interference of forward and backward Bloch waves, and the steady-state tunneling current is substantially amplified, like the sound from a resonating organ pipe. These interference and resonance concepts are key in the creation of quantum devices.

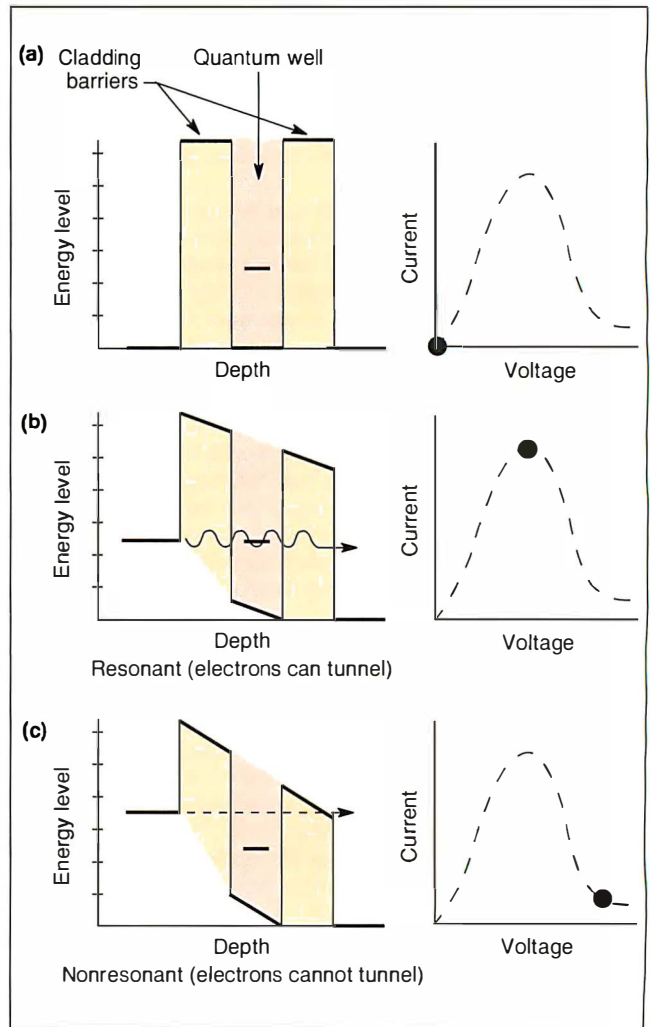

Figure 2: The different states of a resonant tunneling diode: energy level versus depth (left) and the corresponding voltage versus current (right). (a) When the energy level of the source contact is below the quantum state within the well, there is no tunneling. (b) When the source contact level is raised to match that within the well, tunneling occurs. (c) If the source contact level is raised even further, tunneling ceases since the level inside the well no longer matches that of the source.

A Conceptual Quantum Device

To clarify this concept of interference/resonance amplification, let's build a hypothetical quantum device (see figure 3). Let's inject into the device an electron wave packet, which then splits in half and travels down two identical channels. These two electron wave packets are thus coherent—that is, in phase.

Now, let the two wave packets enter boxes A and B, which have the following simple properties:

- If the control switch on the box is set at 0, then the wave packet propagates through the box undisturbed.
- If the control switch is set at 1, the phase of the propagating wave is shifted a half-wavelength (π), making it out-of-phase with the other wave packet.

Now let the two wave packets recombine.

- If the controls A and B were set the same (both 0 or 1), the final electron wave packet is just the same as the initial wave packet: *constructive interference*.
- If the controls A and B are in different states (i.e., A=0 and B=1, or visa versa), the output is zero: The recombined wave packets have destructive interference, and there is no output current.

This is an exclusive-NOR (XNOR) logic function, a basic logic building block. An entire set of complex functions can be designed, on paper at least, and is surprisingly akin to microwave waveguide circuits.

The exciting fact is that such phenomena have recently been demonstrated in microfabricated electronic structures. Though the device described above is far from being realized, wavefunction interference and the "electron waveguide" analogy have been clearly demonstrated. Device physicists, such as Greg Timp and coworkers at AT&T, have microfabricated tiny waveguide structures and found that the system was indeed coherent. The waveguide analogy is very good—perturbations in one part of the system affected the wavefunction of the electron in all other parts of the system. This poses a problem when you try to put contacts onto the structure to measure the electrical properties—the contacts are part of the system and can dramatically affect the measurement. The measurement and isolation of a quantum wavefunction interference device is a major unsolved problem. We presently know more about the quantum devices themselves than how to make contacts to them.

Making Contacts in the Quantum World

To illustrate the problems of making macroscopic contacts to nanoscale quantum devices, let us consider making a quantum tunneling transistor. Starting with the (two-terminal) resonant tunneling diode, how do we make a three-terminal transistor out of a structure whose center region is typically 20 atoms across? The simplistic approach is to manipulate the potential of the quantum well by connecting it to a voltage, like any other transistor. But since the controlling electrons being put into the quantum well also tunnel out along with the current-carrying electrons, it becomes impossible to distinguish between the controlling (base) electrons and current-carrying (emitter-collector) electrons. The formidable problem of soldering to a 50-angstrom-thin layer is beside the point, since it wouldn't do you any good even if you could.

The solution to the problem is easy once the real problem is realized; use a narrower-band-gap quantum-well layer to hide the lowest-lying control electrons' state from the overhead tunneling electrons. The ability to grab hold of and modulate the

potential of a quantum well is a major milestone on the path to creating quantum devices. This solution to the not-so-obvious problem shows that the difficulties in creating quantum devices are often more conceptual than physical.

Quantum Wires and Quantum Dots

The device structures emphasized so far employ quantization in only the vertical direction—that is, in the thin epitaxial direction. I mentioned previously that the thin quantum well was the solid-state analogy of an atom. The atom analogy, however, is good only in the thin epitaxial direction; the other dimensions are unconstrained and thus have no quantum confinement.

The remarkable advances in nanofabrication technology in the last few years have changed this situation. Researchers around the world have demonstrated that they can impose quantum confinement in one or both of the remaining two dimensions; that is, laterally create structures that approach the thin epitaxial dimensions. If an already-confined quantum well is confined in another dimension, it is called a *quantum wire*; if all three dimensions are confined, it is called a *quantum dot*, and it is here that the solid-state atom analogy is exact (see fig-

continued

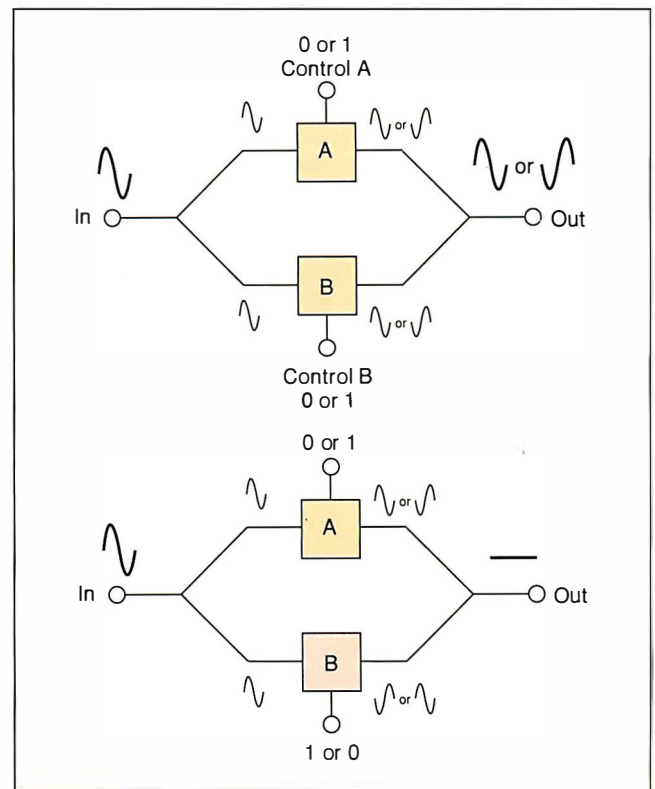

Figure 3: A hypothetical quantum device, into which an electron wave packet is injected. The packet then splits in two and travels down two identical channels toward control boxes. A 0 in a control box indicates that the wave packet propagates through the box undisturbed; a 1 indicates a shift of a half-wavelength in the phase of the propagating wave. If A and B are the same (above), the two wave packets recombine into a wave packet that is unchanged from the original. If A and B are different (below), the recombined wave packets have destructive interference, and there is no output current. Thus, the device forms the basis for the exclusive-NOR (XNOR) logic function, a basic building block for electronic components.

Glossary

band gap The difference between the energy levels of electrons bound to their nuclei (valence electrons) and the energy levels that allow electrons to migrate freely (conduction electrons). The band gap is sensitive to the spacing of atoms in a material.

Bloch wavelength The effective wavelength of electrons in a semiconductor crystal. (See de Broglie wavelength.) A Bloch wavelength is sometimes called an *electron wave packet* or a *wave function*. It can be an order of magnitude larger than the de Broglie wavelength for the same energy.

cladding barrier The higher-band gap material encasing a lower-band gap material that defines the walls of the quantum well.

coherence length The typical distance an electron can travel before it runs into a defect or impurity.

conduction electrons In a conductor or n-doped semiconductor, some of the atom's outer-shell electrons are bound so loosely that they can roam freely throughout the solid. Since the electrons are mobile, the material can conduct electricity.

de Broglie wavelength A particle's wavelength, based on Prince Louis Victor de Broglie's theory that particles exhibit wave-like characteristics.

dopants (n-type and p-type) N-type (negative) dopants, such as phosphorus, come from group V of the periodic table. When added to silicon (from group IV), n-type dopants create a material that contains conduction electrons. P-type (positive) dopants, such as boron, come from group III and result in *holes*.

doping The process of creating semiconductor materials by adding tiny amounts of chemicals to pure crystals of silicon, germanium, or gallium arsenide.

epitaxial layer An added layer of crystal that takes on the same crystal-line orientation as the substrate.

forbidden gap Electrons bound to an atom acquire and release energy in discrete amounts. When atoms of a conductor or semiconductor are placed in a solid, there is a fixed energy level that a given electron must acquire to release it from its parent atom and allow it to become a conduction electron. Since this energy is a fixed amount, it defines a forbidden gap. Electrons cannot exist at energy levels in this gap. They are either below it (and bound to an atom) or above it (and able to move freely).

holes Take an imaginary crystal composed entirely of atoms with four electrons in the outer shell. These are the valence electrons, which take part in chemical reactions. Each atom will form bonds with its neighbors so that its nucleus will be surrounded by four electron pairs. Now remove one atom and replace it with an atom possessing only three valence electrons (a group III element). You've just created a hole—the absence of an electron. It is an amazing fact of nature that this hole exhibits properties of a real particle.

interference (destructive and constructive) When two waves of the same frequency are combined, they can either cancel each other (destructive) or build on each other (constructive). Waves that are out of phase have destructive interference.

molecular beam epitaxy (MBE) Growing thin crystal layers by directing beams of atoms or molecules at the semiconductor. The process takes place in a high vacuum, and the thin layers are crystals aligned with the crystal substrate.

potential gradients The difference in voltage per unit of distance in a conductor or semiconductor material.

quantized states Discrete levels of energy due to the quantum-mechanical properties of the material.

scattering centers The necessary impurities (dopants) in semiconductors cause the electrons flowing through the

semiconductor to scatter. This is not a problem for the operation of traditional semiconductor devices. However, when designing quantum devices, the electron-wave properties must remain coherent.

silicon dioxide gate dielectric A dielectric is a material that resists the flow of electrons. In the process of making semiconductor devices, the silicon is oxidized to form silicon dioxide (a dielectric). This material is used as an electrical insulator. Most of it is eventually etched away, but some is left in patterns on the device to create necessary electrical separation of the elemental components (gates) of the device.

III-V compounds The columns in the periodic table of elements are called groups. Elements in a group have similar chemical properties. Elements from a different group than that of the host material can be used in semiconductors. Gallium, for example, is a group III element and arsenide is from group V, making GaAs a III-V compound.

tunneling The quantum-mechanical process that demonstrates the wave nature of particles. The term is applied to the ability of electrons to penetrate a barrier that would be impenetrable by classical physics. The invention of the tunnel diode in 1957 moved tunneling from a theoretical concept to a practical reality in semiconductor devices.

two-dimensional electron gas (2DEG) In an electron gas, the electrons move around without apparent restriction. The behavior of electrons in conducting metals (such as copper) is an example of a three-dimensional electron gas (3DEG). In a 2DEG, motion is restricted to a single plane (two dimensions).

waveguide Because of the behavior of microwaves, tubes (rather than wires or free space) are used to channel them. The size and shape of the tube influence the transmission, propagation, and filtering of microwaves. These specialized tubes are called waveguides.

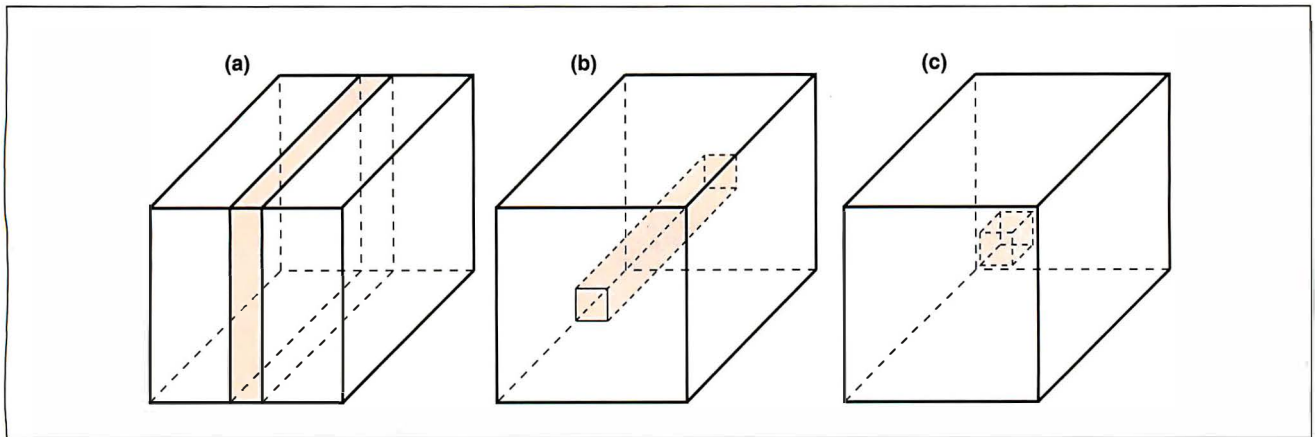

Figure 4: (a) Restriction by one dimension results in a quantum well; (b) restriction by two dimensions produces a wire; (c) restriction by three dimensions produces a dot.

ure 4). Precise control of this quantum confinement and the resulting electron energy structure are the second key ingredients in the creation of quantum devices.

Research into quantum wires began in the early 1980s, mostly in metal systems. Researchers discovered the importance of relevant scattering and coherence lengths and realized that the effects would be much larger in semiconductor systems. Today, many university and industrial laboratories throughout the world use quantum-wire technology. Daily, there are new achievements in the basic physics of quantum-wire electronics (i.e., quantum waveguides) and in the properties of enhanced devices using this technology.

However, the development of quantum dots has been significantly slower. Only within the last year, when we at Texas Instruments implemented a method for putting tunnel barriers and contacts onto the sides of a quantum dot, was anyone able to see the first evidence for the creation of totally quantum-confined states. Now, researchers are using these "atoms" to explore the fundamentals of quantum-confined states.

Now that we can make "atoms," the next step is to build "molecules." Consider two quantum dots, patterned in close proximity with a tunnel barrier between them. If the two dots are different sizes, the energy levels will not line up, and electrons in one of the dots cannot resonantly tunnel into the other. However, if a bias is applied to make the energy levels line up, electrons can resonantly tunnel from one dot to the other.

Bob Bate of Texas Instruments pioneered this new genre of quantum devices. He showed that it is easy to construct multi-terminal transistors and any possible logic function from similar structures. Here, the quantum dot is of particular interest because the total absence of states at energies intermediate between the quantum levels (i.e., no unconstrained dimension) means that electrons only tunnel between dots that have equivalent energy levels. This development is important for digital switching applications, where the ideal is to be able to hold off the supply voltage with minimal leakage current and to use a third terminal to create a nearly instantaneous switching into a highly conductive state.

The Future of Quantum Devices

To envision how quantum devices will be used, first realize that the limitations of present VLSI technology are due not only to device degradation but also to a multitude of problems: interconnection overhead, system noise, and alpha particle events, among others. In essence, simply replacing today's devices

one-for-one with nanoscale quantum devices does not solve the scaling limit problem. The implication is that quantum devices must be used in designs with noise tolerance. But this research is not even as far along as research in device technology. Researchers have identified a number of strong candidate architectures, such as cellular automata. Before we can use quantum devices in complex functions, we need to do more work on quantum device coupling and contact effects.

If these devices are only tens of nanometers across and operate by the tunneling of only a few electrons, how are we to bring signals in and out of these tiny structures? This problem turns out to be much less daunting than we initially thought.

Researchers at Bell Labs, Cornell, and Texas Instruments have discovered that quantum wires are excellent amplifiers. At the quantum level, electrons are like tiny wave packets; in a quantum wire, they travel straight through the wire without bouncing to either side. We have found out that if we put a small charge, even a single electron, in the middle of a quantum wire, there is tremendous blockage. In large structures that are not quantum wires, the wave packets can bounce to the side and go around. However, in a quantum wire, the wave packets are restricted to two directions—forward or backward. The wave packets are simply a substantial electrical current, and a single electron in the quantum wire can produce a phenomenal amplification of 10^{11} per second per electron. Although we are still working on developing a method for coupling the single-electron output of one quantum device to quantum-wire amplifiers, this will soon be a reality.

The creation of quantum wires and dots, phase-coherent structures, controllable tunneling, and single-electron output amplifiers are all key steps toward a complete quantum-device technology. We still need to develop a method of controllably defining the locality of nanoscale contacts, and we still need to completely define a workable architecture. The pursuit of a revolutionary (rather than evolutionary) semiconductor technology is inherently risky, but the alternative is hardly acceptable, and the anticipated rewards are enticing. ■

Mark Reed has a Ph.D. in physics from Syracuse University. He is currently senior technical member at the Advanced Concepts branch of Texas Instruments' central research laboratories. His areas of research have centered on subjects involving quantum mechanics, and he holds five U.S. patents on quantum devices. He can be reached on BIX c/o "editors," and on Usenet at unnet!resbld.csc.ti.com!reed.

Quality In... Quality Out



No matter how well acquainted you are with making important personal computing decisions—decisions that may involve hundreds of thousands of dollars—the value of those decisions is only as good as the value of your information. Without quality information—it's hard to make quality decisions.

BYTEweek, McGraw-Hill's new weekly newsletter for professionals in the personal computer industry, is devoted to giving you that quality information through its timely and compact one-stop news format.

This new publication provides you with short, easy-to-read selections of the most important news and technological developments of the past week. And BYTEweek interprets this news with in-depth commentary and analysis.

Subscribe to BYTEweek for quality information. Remember, quality in...quality out.

Subscribe now and take advantage of the special one-year charter subscription rate of \$395 (\$495 outside the U.S. and Canada). This special price represents a savings of \$100 off the regular rate. Your subscription includes 50 issues plus a free three-month subscription to BIX—a \$49 value. Through BIX you can directly access the Microbytes Daily news service and communicate with other BIX users.

Don't miss this opportunity! In the U.S., call BYTEweek's toll-free number: **1-800-258-5485**, in N.H. and outside the U.S., call: 1-603-924-9281.

BYTEweek offers a *money-back guarantee* if you're not completely satisfied.

BYTEWEEK 

News and Analysis for Professionals in the Personal Computing Industry
One Phoenix Mill Lane, Peterborough, NH 03458

DIGITAL VIDEO INTERACTIVE

Digital audio, video, still pictures, and computer graphics come together in a personal computer environment

Imagine touring the jungles of the Yucatán peninsula from your easy chair. Using a joystick and your computer's screen, you "walk" through ancient Mayan ruins, zooming in to take a closer look at artifacts and wildlife. Sounds of water, insects, and jungle animals surround you, realistically shifting their relative positions as you slowly turn 360 degrees to get a full, seamless view of your surroundings. You explore the underground maze of a Mayan palace, track your progress on a map of the site, enter a rain forest, and watch birds and monkeys in the trees overhead. All along the way, the voice of an expert archaeologist describes important features of what you see.

You then enter a video "museum," with theme rooms containing more information about the site. Using the joystick to select icons and objects, you view pictures of Mayan ruins as they looked before and after restoration, piece together the fragments of an ancient glyph, listen to the voices of howler monkeys, and piece together your own "jungle symphony" from a selection of sound clips.

I took this very "tour" in January—and the first commercial systems may be available by this summer, thanks to an ingenious marriage of digital technologies known as *digital video interactive*.

The DVI technology combines motion video, still pictures, multitrack audio, and computer graphics in a single integrated environment controlled by a personal computer. Implemented by boards

and chips soon to be manufactured in quantity by Intel, DVI provides all the facilities necessary to produce truly exciting interactive-video presentations.

An All-Digital Approach

Already, a few systems provide interactive audio, video, and computer graphics. For instance, the popular arcade game *Dragon's Lair* lets you move about a dungeon, fighting monsters in a quest for a beautiful princess. Also, the U.S. Army uses a system called EIDS for interactive training. These systems use videodisks as the source of video and audio material; as you make choices, the head jumps to a different track, which contains a simulation of the result.

This approach, while practical for some applications, has three main drawbacks. First, you can make only a limited number of choices, and only those that were "expected" by the system's designers. Second, there are usually marked, and often annoying, interruptions in the video and audio as the laser-disk head moves to a new location. Finally, computer-generated text or graphics, if desired, must be superimposed on the video image after the fact. Usually, this requires additional computer graphics hardware and complex genlock circuitry to synchronize the video from the two sources.

A key goal of DVI is to eliminate the expense, complexity, and awkwardness of a part-analog/part-digital system by storing and processing everything as digital data. DVI uses a single storage device and a single set of chips to produce live-action video, synthetic video, and audio, all under the direct control of a personal computer. The result is a system that is far more interactive and sheer fun to use than anything that has come before.

Video Compression

The first—and most exciting—component of DVI is advanced video data compression. Extremely good compression,

especially of video, is necessary because an uncompressed video image takes up large amounts of memory. One demonstration I watched showed gymnasts and figure skaters performing at high speed. The image consisted of 256 pixels by 240 pixels, with 24 bits per pixel (8 bits each for red, green, and blue).

At this resolution and a standard television rate of 30 frames per second, it would have taken only 96 seconds' worth of uncompressed data to fill up a standard half-gigabyte CD-ROM disk. And, since a CD-ROM can transfer data at only 150K bytes per second, there's no way the disk could have kept up with the demand for data.

DVI addresses this problem by providing extremely efficient compression and fast decompression of video information. Since the greater part of a video image doesn't change from frame to frame, only the differences between successive frames are recorded. Special hardware to handle compression mechanisms like a CLUT (color lookup table) and *chrominance subsampling* (see the text box "Chrominance Subsampling" on page 284) is built into the DVI chip set. Additional proprietary techniques pack the information still further.

The compression algorithms take into account the fact that only decompression must be done in real time, shifting as much of the computational burden as possible to the device that compresses the video. The final result is more than an hour of full-screen motion video and multichannel audio on a single CD-ROM disk—all of which can be played back in real time.

Currently, the practical minimum size of a compressed video frame is about 5K bytes; more compression usually introduces undesirable artifacts. However, because the DVI hardware is easily reprogrammed, none of the compression algorithms are fixed in stone. This flexibility will let DVI grow as the state of the

continued

Chrominance Subsampling

Scientists theorize that it was more important for primal humans (and their evolutionary ancestors) to be able to precisely locate boundaries between light and dark areas than to be able to detect differences in color. For this reason, they say, the color-sensing *cones* of the human retina are distributed more sparsely than the more sensitive but noncolor-sensing *rods*. Digital video interactive, like color television, takes advantage of the resulting trait of the human eye: The spatial resolution of color vision is lower than that of non-color vision.

In DVI's special 9-bit-per-pixel video-encoding scheme, the colors and brightnesses of pixels are encoded not as RGB components but as Y-C components: luminance, or brightness, plus

two values that describe the hue and saturation of the color. The luminance (Y) bit map is used at its full resolution, while the color values (C₁ and C₂) are recorded for only every fourth pixel in each direction. The result is a set of three bit planes, as shown in figure A.

When VDP2 displays images in this mode, it automatically interpolates the colors of each pixel for which no chroma information is available from the colors of its neighbors.

Chroma interpolation works well on images with no sharp borders between saturated colors; however, it will produce bleeding if used with most conventional computer graphics. VDP2 solves this by switching to other display modes—like a 256-color lookup table—on a pixel-by-pixel basis, if necessary.

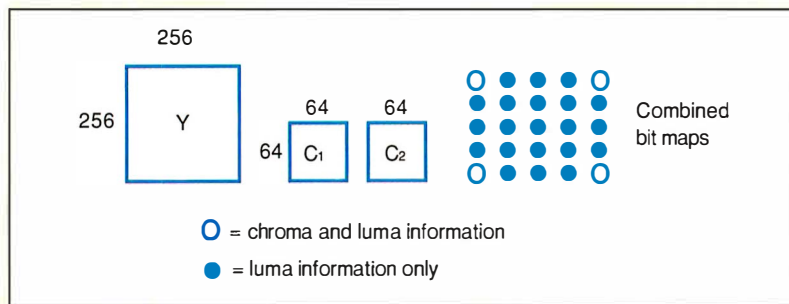

Figure A: Chrominance subsampling takes advantage of the fact that the eye has less spatial sensitivity to color than to brightness. Three bit planes, two of them at one-quarter resolution, are used to reproduce the image by interpolating colors between the points.

art advances, while allowing new systems to be downward-compatible with materials produced for older ones.

The DVI hardware can also compress and decompress still images with compression ratios of up to 25-to-1. Exact reproductions of detailed graphics and medical illustrations can be done at ratios between 2-to-1 and 3-to-1 (see "Chrominance Subsampling").

Audio Compression

The compression of audio information poses different, but equally challenging, problems. Audio doesn't exhibit as much regularity as video, so it's not as easy to interpolate future waveforms from earlier ones. Also, audio must be contiguous. Most of us are used to video sequences that jump from take to take, but discontinuity in an audio signal can be jarring.

DVI provides audio compression via an ADPCM (for adaptive differential pulse code modulation) algorithm and uses special buffering techniques to prevent discontinuities in the sound, even during the long step times of CD-ROM heads. Typically, the compressed audio will take from 4K to 16K bytes per second (more if there are more tracks).

Synthetic Video

Along with the ability to reproduce compressed video sequences, DVI has facilities to create computer-generated images in real time. The hardware supports both bit-mapped graphics and "structured" graphics (in which objects are created from primitive graphics elements like polygons and curves) directly, and there are facilities for bit-mapped (and, potentially, stroked) text fonts.

DVI uses special hardware to perform

the *warp* algorithm, which very quickly maps a pattern or texture onto a simulated two-dimensional or three-dimensional surface. The sample application called Design and Decorate (see photo 1) demonstrates this feature by allowing you to "reupholster" sofas and chairs with different fabric patterns in a fraction of a second, then arrange them in a simulated room to see how they'll look. The DVI hardware and software generate realistic shadows and textures, and they let you change vantage points almost instantly.

Another demonstration program, Flight Simulator (see photo 2), shows realistic textured images of buildings as you fly over the landscape—including a billboard with a picture of Nipper, the RCA dog, listening to "His Master's Voice" (a reminder that the DVI development team was originally part of RCA Laboratories; see the text box "A Brief History of DVI" on page 287). Yet another demonstration is a tutorial on Photography (see photo 3): The screen becomes your viewfinder as you frame, focus, and shoot pictures using the joystick. And in the Landscaping demonstration (see photo 4), you can arrange shrubs and trees in your garden and then watch them grow to maturity before your eyes.

The DVI Hardware

At the heart of DVI technology lie two chips—VDP1 and VDP2—that together form the video display processor (see figure 1). The first versions of these two chips, implemented in 2-micron CMOS, were designed using Silicon Compiler Systems' automated chip-design software, and they were built by VLSI Technology.

The use of silicon compilers was an important trade-off: It brought the system to market quickly, but the very nature of silicon compiling limited the speed and complexity of the chip set. Intel is now at work on a fully customized chip design, which is likely to be significantly smaller and faster.

VDP1, or the pixel processor, is a horizontally microcoded microprocessor that runs at 12.5 million operations per second (MOPS). It uses a wide instruction word and has no permanent microcode; all the code it executes is loaded from dual-ported video RAM (VRAM) into an on-chip instruction RAM before being run.

Because the on-chip microcode store is not nearly large enough to hold all the routines that might be used to produce a single scene, VDP1 has the ability to

completely reload that RAM in less than 120 microseconds—the time it takes a standard video monitor to scan two lines. In fact, VDP1 typically reloads microcode several times during every frame of a text/graphics display.

The wide microcode word can cause several operations to occur concurrently within VDP1. Address calculations and pixel processing go on at the same time. Counters for the inner loops of graphics operations increment as the operations happen. Using special hardware, VDP1 can perform the warp algorithm on 500,000 pixels a second—much faster than any general-purpose processor now available.

VDP1 can perform the warp algorithm on 500,000 pixels a second.

Because they expected the DVI architecture to evolve, its developers were careful to make provisions for the format of the microcode word to change with the

technology. Instead of storing the microcode in a raw binary format, the system keeps it in a *logical* format on the disk and translates it into *physical* microcode only when moving it into VRAM. This design will make it easy to provide downward compatibility in later versions of the chip set.

In all cases, data must be moved into the on-chip data RAM before it can be manipulated. Because the chip's novel architectural features are the subject of several patent applications, Intel hasn't disclosed the width or organization of the internal data paths. However, Intel has stated that the on-chip data RAM is large

continued

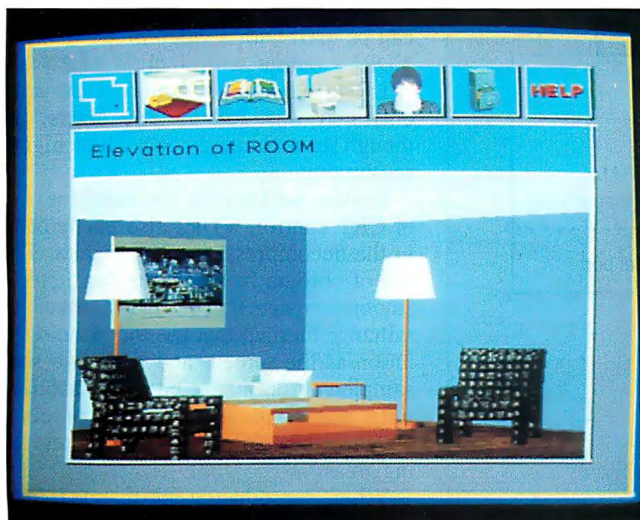

Photo 1: *Design and Decorate*, developed by Intel and Videodisk Publishing, lets you move and “reupholster” furniture to achieve a pleasing interior design.

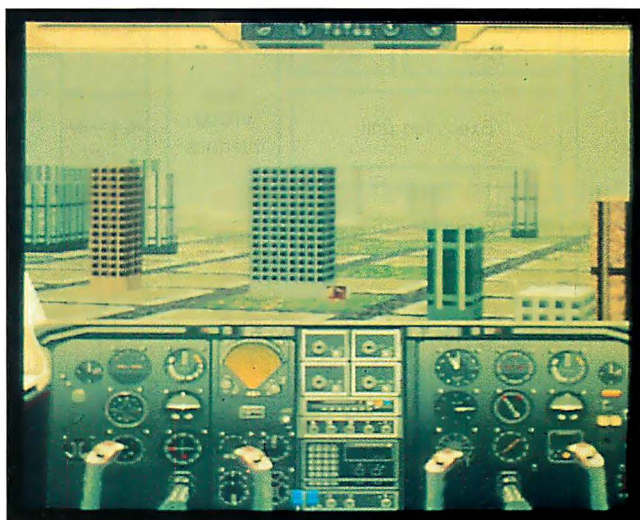

Photo 2: *The Flight Simulator* demonstration puts you in the cockpit of a simulated airplane that flies among realistic landmarks.



Photo 3: *Photography* teaches camera novices how to compose and focus pictures (notice the simulated depth of field in this picture).



Photo 4: *Landscaping* lets you plan a garden and view it as it will look at different stages in the life cycles of shrubs and trees.

enough to hold some or all of the last video scan line—an important feature for image processing. The designers were careful to match VDP1's requirements to the bandwidth of current VRAMs. Most of the available bandwidth is used, but the processor rarely has to wait for access.

The host system—which is currently an IBM PC AT—controls VDP1 via a bank of 256 16-bit registers. The host can also access the VRAM—up to 16 mega-

bytes of it—via an EMS-like paging scheme. VDP1 can generate interrupts on the host CPU (for itself or on behalf of VDP2) to signal events that occur in either video chip.

A Super CRT Controller

VDP2, or the output display processor, acts as a super CRT controller for the DVI system. It isn't directly accessible via the host system bus; instead, it programs itself by loading values into inter-

nal registers from VRAM (much as the copper loads the video registers in the Amiga's custom chip set). The registers are always reloaded at the end of every frame, but they can also be reloaded more often under software control. VDP2 can send signals back to VDP1 via the 4-bit VBUS interface.

VDP2 extracts data from VRAM via a 32-bit-wide multiplexed bus connected to the VRAM serial ports and maps it, via a specially designed *pixel data path*, to a CRT display.

The output to the D/A converters is 32 bits per pixel. Of these, 1 byte is used for luminance (brightness), 2 bytes for chrominance (color), and 1 byte for the *alpha channel*, a special-effects channel that can be used with a video mixer to blend VDP2's output with another video signal. The maximum resolution I saw demonstrated was 768 by 480 pixels, although the technology does allow higher resolutions.

Besides performing the mundane task of CRT control, VDP2 also participates in the decompression of pixel data. The use of chroma interpolation facilitates a smooth construction of images from a luminance bit map that has the same resolution as the screen, and from two sub-sampled chrominance bit maps that have only one-sixteenth as many pixels—blending the colors to fill in the intervening areas.

When reproducing bit-mapped text, icons, a mouse pointer, or other portions of the screen that contain sharp boundaries between colors, VDP2 can switch on a pixel-by-pixel basis to a CLUT to get precise color information without interpolation. It can also display noncompressed data stored in 16- or 32-bit-per-pixel formats.

VDP2 can also organize the storage of pixels in VRAM during video digitization. In fact, while VDP2 takes care of these logistics, VDP1—which would otherwise sit idle—can work on compressing the digitized images as they arrive.

The combined power of VDP1 and VDP2 is impressive. Intel's Microcode demonstration plays the game of Life in one window, displays full-motion video in another, and pans a third window smoothly about the screen image.

VDP1 and VDP2 sit together with VRAM and interface logic on one of the three boards that currently make up the DVI interface. A single-board implementation is expected to be available by the end of this year. The DVI audio processor and the DVI utility board complete the set.

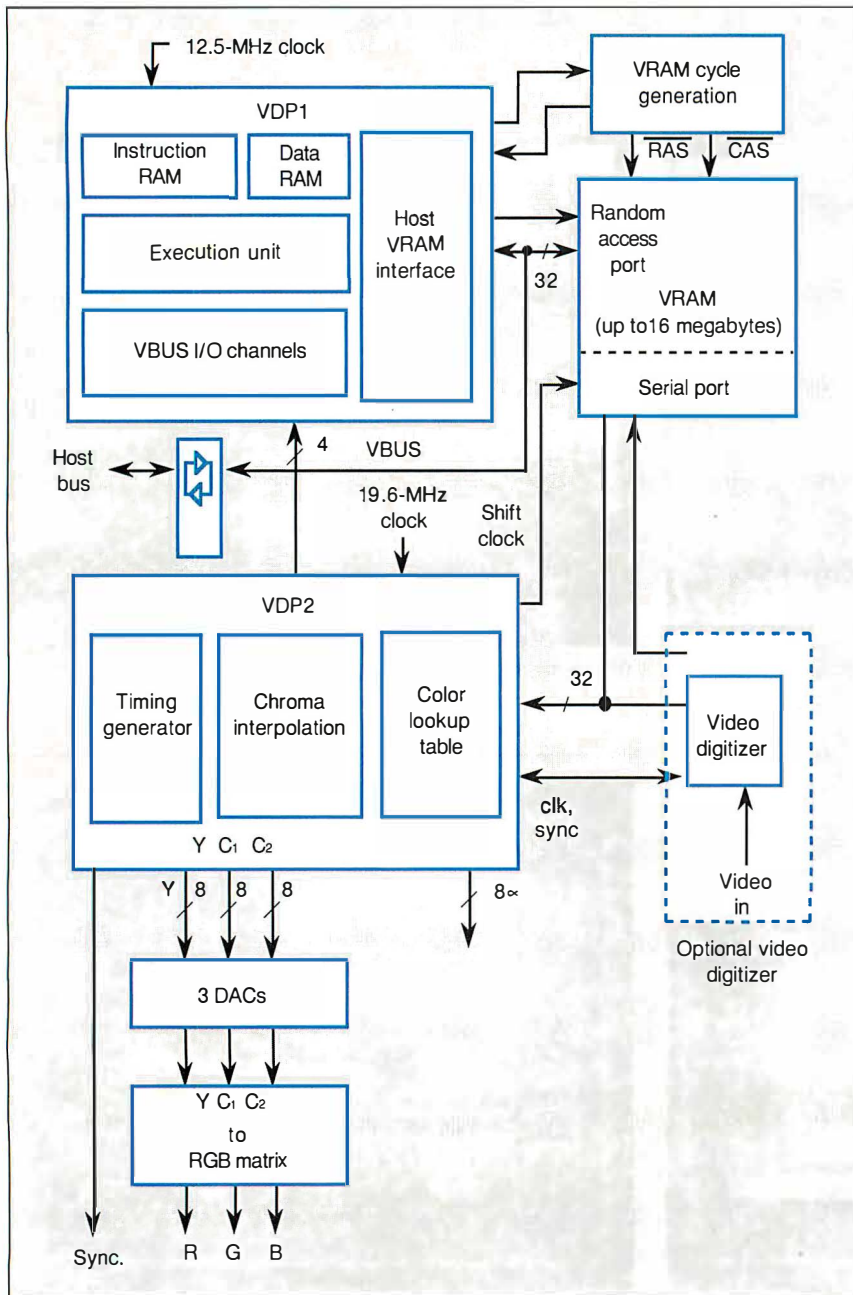

Figure 1: The digital-video-interactive video subsystem consists of the VDP1 pixel processor, the VDP2 output display processor, video RAM, a host interface, and an optional video digitizer board.

A Brief History of DVI

Digital video interactive was conceived by Larry Ryan of the David Sarnoff Research Center (then RCA Laboratories) in 1983. At that time, RCA began working on schemes to make its LaserVision analog videodisk system interactive, with unsatisfying results. Ryan suggested an all-digital approach, and he received approval from his boss, Art Kaiman, to test its feasi-

bility. Within one year, they were satisfied that DVI was possible, and Kaiman's entire staff was working fiercely on the project.

The effort continued for six years, while the group weathered numerous budget cuts and changes of management. RCA dropped out of the videodisk and home computer businesses and was acquired by General Electric. To save

time, the design moved directly from computer simulations to silicon; no board-level prototype was ever built. Despite a warm reception at the 1987 CD-ROM Conference, the DVI effort didn't mesh with GE's strategic plans, so GE, in turn, donated the Sarnoff Research Center to SRI International (retaining control of the technology). Finally, GE sold the technology to Intel.

The DVI Audio Processor

The DVI audio processor uses a Texas Instruments TMS320C10 digital signal processor to record and decompress audio in real time. Running at a clock rate of 25 MHz, it executes most instructions in four cycles, for a net speed of 6.25 MOPS. The digital signal processor has a small internal data RAM (144 16-bit words) that is supplemented by 16K bytes of dual-ported DRAM (shared with the host) and 8K bytes of high-speed (50-nanosecond) program RAM. An optional audio digitizer attaches as a piggyback board.

The audio processor offers three levels of digitized audio, encoded as 4K, 8K, and 16K bytes per second. The lowest quality, with a bandwidth equivalent to that of AM radio or a telephone connection, is suitable for speech; the highest quality is superior to what you'll hear on a typical FM radio program. It's also possible—at least in theory—to synthesize arbitrary waveforms using the audio processor.

The audio processor is a complete subsystem by itself, and it can be run independently of the other DVI hardware. The software interface to the processor is also defined in such a way that the implementation can be changed (i.e., a different digital signal processor can be used) without changes to DVI applications.

The DVI Utility Board

The utility board provides three functions: a dual joystick interface, 128K bytes of DRAM (to top off the memory of a standard AT at 640K bytes), and a CD-ROM interface with a full sector buffer. (While a CD-ROM disk isn't absolutely necessary to run DVI applications—they run equally well from a hard disk—it's an excellent distribution medium due to its large capacity and low cost.)

Intel hopes to improve data throughput in future systems by providing a direct data path between the CD-ROM inter-

face and the audio and video subsystems: a *DVI bus*. This will free the host system from the arduous task of shuttling data from the utility board to the other boards in real time.

The DVI Software

All activities of the DVI boards are controlled by a layered set of software routines provided by Intel (see figure 2). At the lowest level are the TSR drivers for VDP1, VDP2, the audio processor, and the utility board. There is also MS-CDEX (Microsoft CD-ROM extension), which allows access to the CD-ROMs through DOS. (This driver is necessary only if a CD-ROM disk is used as the DVI storage medium.)

On the next two levels, provided by linkable object code libraries, are driver interface modules, which give the pro-

grammer direct low-level control of each DVI subsystem, and the graphics and AVSS (audiovisual subsystem) libraries, which provide complex functions involving more than one subsystem. At the top of the hierarchy is the DVI application.

Two key parts of the DVI software are RTX (real-time executive), which performs real-time multitasking on the AT, and AVSS, which allows DVI applications to issue high-level commands like, "Play back this audio/video sequence now." These subsystems hide much of the complexity of real-time I/O control, letting the developer concentrate on the creative aspects of the application.

The Compression Process

All the video and audio, as well as most of the still images and other information

continued

CD-ROM, CD-I, and DVI

What are the differences between CD-ROM, compact disk-interactive, and digital video interactive?

CD-ROM, as defined by the Philips/Sony *Yellow Book* and the International Organization for Standardization 9660 standard, is merely a way of encoding data files on a CD-ROM disk. It doesn't say anything about what's in the files or how they are used.

CD-I, as defined by the Philips/Sony *Green Book*, is a specification for a complete hardware/software product that includes a CD-ROM player, a Motorola 68000-family CPU, and special audio- and video-processing hardware. Intended for the consumer market, it's designed for price-sensitive applications; keyboards and read-write storage media are options. CD-I has a wide range of capabilities, including CD-quality audio (which DVI does not

have), but it cannot display continuous full-screen, full-motion video, and it cannot run on hardware that doesn't precisely conform to the specification.

DVI is a more generalized technology that does not require specific hardware other than the DVI chip set. Unlike CD-I, it's suited for use with forms of mass storage other than CDs, like WORM (write once, read many times) disks and magneto-optical disks. Also, it can work as a peripheral of many different kinds of computers. (It's possible, at least in theory, to run windowing environments like X Windows, NeWS, and Presentation Manager on or through the DVI hardware.) DVI can display full-screen, full-motion video, and the internal graphics CPU—as well as the host CPU—can be programmed to execute new special effects and data-decompression algorithms.

found in a DVI application, must be compressed to fit on a CD-ROM disk or other reasonably priced personal computer storage medium. The operation is highly computation-intensive; Intel currently performs video compression on a Meico array processor with 64 INMOS transputers working in parallel. Even with this much horsepower, each video frame takes 13 seconds to compress—400 times slower than it will actually run (ongoing research, as well as more transputers, is likely to reduce this figure).

In Intel's current compression process, it first transfers the video material from tape to a high-speed disk at the full frame rate, then backs it up onto WORM (write once, read many times) disks and compresses it on the array processor. After the initial compression pass, Intel examines the images for artifacts and makes some final touch-ups, if necessary, before returning the resulting compressed video to the customer (usually on cartridge or 9-track tape).

The quality of the video input is vi-

Intel is currently the only vendor of video and audio compression services, but this will change.

tally important to the compression process. Any form of distortion or noise present in the source material is likely to be amplified by the compression process, and this may also reduce its efficiency. Thus, Intel currently accepts material only on 1-inch videotape (though it may accept other formats of similar quality in the future). Some images compress

better than others. Images with saturated colors, for instance, are likely to bleed due to the chrominance-subsampling techniques used in the video subsystem.

At this writing, Intel is the only vendor of compression services, but this will change. Third parties will be granted licenses to use Intel's software on their own hardware to satisfy customers' compression needs.

Authoring a DVI Application

How do you author your own DVI application? In the early days of DVI, when the initial demonstration programs were created, there was little in the way of authoring tools. The Palenque demonstration, created by Intel in conjunction with the Bank Street College of Education, was largely coded by hand using the evolving run-time libraries, C, assembly language, and VDP1 microcode. Video and audio had to be edited prior to digitization and compressed by a mainframe computer before they could be viewed.

Fortunately, better authoring tools are

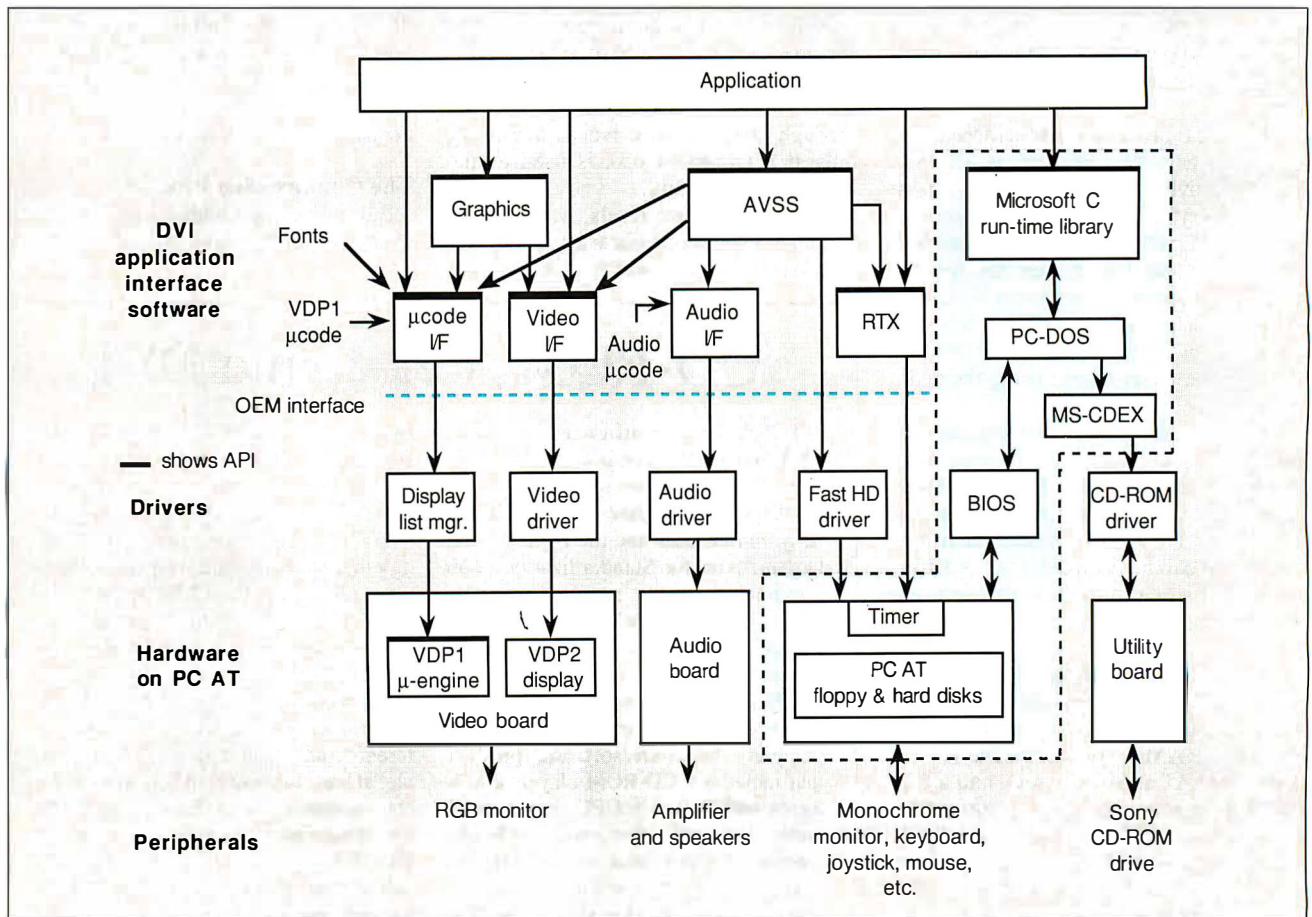

Figure 2: The digital-video-interactive run-time software is layered and modular. The low-level device drivers are implemented as TSR programs; the higher-level software is packaged as run-time libraries for the C language. There are facilities to directly execute custom microcode on VDP1.

Order **BYTE** and **BIX** on disk Today!

Full Text of **BYTE** on Disk

Now you can order disks containing the full, machine-searchable text of articles. You can read and search the text with any word-processor. Excellent for reference and research! Disks can be ordered singly or by annual subscription. Full text of **BYTE** is available starting from September 1988.

BYTE Program Listings on Disk

BYTE listings on disk are the right choice if you want to compile or read the complete source code listings of programs. **BYTE** listings are available from December 1985 to present at the prices stated below.

Best of **BIX** on Disk

Receive highlights of each month's activities on **BIX**—**BYTE**'s world-class on-line conferencing system. You can read and search the text with any word processor. Each disk contains the most interesting and informative recent discussions specific to the machine you own. For example, order the **IBM** disk, and get the highlights from **IBM**-specific conferences. Disks can be ordered singly or by annual subscription.

BYTE also offers listings in print form. Order bound versions of the complete source code listings of programs excerpted from our articles. Handy for quick reference. Order singly or by annual subscription; with or without accompanying diskette version.

Call toll-free for more information: 800-258-5485.

ORDER FORM: To place your order, fill out the card and mail.

| | IN USA | | OUTSIDE USA | |
|--|--|--|--|---|
| | Single Month (1 disk) | Annual Subscription (13 disks) | Single Month (1 disk) | Annual Subscription (13 disks) |
| 5-1/4 Inch: <input type="checkbox"/> IBM PC <input type="checkbox"/> Other disk formats available. Call toll-free. | <input type="checkbox"/> Full Text of BYTE \$9.95 <input type="checkbox"/> BYTE Listings \$9.95 <input type="checkbox"/> Best of BIX \$9.95 | <input type="checkbox"/> Full Text of BYTE \$79.95 <input type="checkbox"/> BYTE Listings \$79.95 <input type="checkbox"/> Best of BIX \$79.95 | <input type="checkbox"/> Full Text of BYTE \$12.95 <input type="checkbox"/> BYTE Listings \$12.95 <input type="checkbox"/> Best of BIX \$12.95 | <input type="checkbox"/> Full Text of BYTE \$99.95 <input type="checkbox"/> BYTE Listings \$99.95 <input type="checkbox"/> Best of BIX \$99.95 |
| 3-1/2 Inch: <input type="checkbox"/> Apple Macintosh <input type="checkbox"/> Atari ST <input type="checkbox"/> Amiga <input type="checkbox"/> IBM PS/2 | <input type="checkbox"/> Full Text of BYTE \$10.95 <input type="checkbox"/> BYTE Listings \$10.95 <input type="checkbox"/> Best of BIX \$10.95 | <input type="checkbox"/> Full Text of BYTE \$89.95 <input type="checkbox"/> BYTE Listings \$89.95 <input type="checkbox"/> Best of BIX \$89.95 | <input type="checkbox"/> Full Text of BYTE \$13.95 <input type="checkbox"/> BYTE Listings \$13.95 <input type="checkbox"/> Best of BIX \$13.95 | <input type="checkbox"/> Full Text of BYTE \$109.95 <input type="checkbox"/> BYTE Listings \$109.95 <input type="checkbox"/> Best of BIX \$109.95 |

**FOR DIRECT ORDERING
CALL TOLL FREE:
800-258-5485**



**Call: M-F, 8:30 a.m. to
4:30 p.m. Eastern Time
(603-924-9281 for New
Hampshire residents)**

**For credit card
orders only.**



PLEASE COMPLETE IN FULL

MAY

Name _____

Address _____

City _____

State _____

Zip _____

County or Parish _____

Country _____

Credit Card # _____

Exp. Date _____

Signature _____

Date _____

Please allow 4-8 weeks for delivery.

• Please indicate the issue date below. If you are beginning an annual subscription, note the starting issue.

Full Text of **BYTE**

Month _____ Year _____

BYTE Program Listings

Month _____ Year _____

Best of **BIX**

Month _____ Year _____

Check enclosed

MasterCard

VISA

U.S. funds enclosed

(if ordering from outside the U.S. please remit in U.S. funds drawn on U.S. bank. Thank you.)

Order **BYTE** and **BIX** on disk Today!

Full Text of BYTE on Disk

Now you can order disks containing the full, machine-searchable text of articles. You can read and search the text with any word-processor. Excellent for reference and research! Disks can be ordered singly or by annual subscription. Full text of BYTE is available starting from September 1988.

BYTE Program Listings on Disk

BYTE listings on disk are the right choice if you want to compile or read the complete source code listings of programs. BYTE listings are available from December 1985 to present at the prices stated below.

Best of BIX on Disk

Receive highlights of each month's activities on BIX—BYTE's world-class on-line conferencing system. You can read and search the text with any word processor. Each disk contains the most interesting and informative recent discussions specific to the machine you own. For example, order the IBM disk, and get the highlights from IBM-specific conferences. Disks can be ordered singly or by annual subscription.

BYTE also offers listings in print form. Order bound versions of the complete source code listings of programs excerpted from our articles. Handy for quick reference. Order singly or by annual subscription; with or without accompanying diskette version.

Call toll-free for more information: 800-258-5485.

ORDER FORM: To place your order, fill out the card and mail.



NO POSTAGE
NECESSARY
IF MAILED
IN THE
UNITED STATES

BUSINESS REPLY MAIL

FIRST CLASS MAIL PERMIT NO. 10 PETERBOROUGH, NH

POSTAGE WILL BE PAID BY ADDRESSEE

BYTE & BIX on Disk

One Phoenix Mill Lane
Peterborough, NH 03458-9990



now in place, and by the third quarter of this year, Intel will release utilities that will eliminate most or all of the need to program in C, assembly language, or microcode when writing DVI applications (though it will certainly still be possible to do so). Contemplating a wide variety of possible applications, Intel has rejected the notion of a "standard user interface" for DVI, but it will provide the software tools required for application developers to create their own.

Intel's most significant breakthrough in the area of authoring tools is Edit Level Video, a facility that lets the developer digitize and compress video in real time using just the DVI board set. While the quality isn't as good as that done by a large computer and may produce some visual artifacts, ELV provides a digitized version of the video that the author can edit directly on the DVI system and then use to develop an application.

During editing, the authoring software compiles an *edit decision list*—a list of the Society of Motion Picture and Television Engineers time codes where each video sequence starts and stops. This list, together with a high-quality master tape of the video, is fed to the "production" compression system to create high-quality (Presentation Level) video. The steps that you go through to produce a complete application are roughly as follows:

1. Digitize the video footage using ELV.
2. Digitize the audio.
3. Use editing tools to select the desired video and audio sequences.
4. Add the programming, computer graphics, menus, icons, and still images.
5. Send the original videotapes and the edit decision list to a vendor for compression.
6. Replace the ELV with Presentation Level Video (the standard DVI routines let this be done without recompilation of the DVI application).

How much does it cost to produce a DVI application? This figure can vary greatly depending on the nature of the material involved. A demonstration program called Words in the Neighborhood, created in conjunction with the Children's Television Workshop, tapped a library of 20 years' worth of high-quality video material developed for the television show *Sesame Street*; all that was necessary was to pick the sequences and

add a user interface.

A similar application created from scratch, however, would incur the same production costs as an equivalent video presentation: Actors, camera crews, editing, lighting, and scripting will likely account for the bulk of the cost. Programming costs may also become significant if sophisticated computer graphics, custom user interfaces, or custom microcode are required.

Once the application is developed, the rest of the process is relatively inexpensive. Presentation Level Video compression costs roughly \$300 per finished minute of full-screen images; mastering and pressing a CD-ROM costs anywhere from \$2000 to \$8000. (For some applications—especially those that won't be mass-marketed—it's possible to skip both of these steps and distribute applications with ELV on high-capacity tape cartridges or hard disks.)

An Interactive Future

Intel's marketing plans call for the first DVI-based systems to be available in June. In keeping with its traditional marketing approach, Intel will offer products on all levels: Chips, boards, systems, driver software, development tools, and compression services will all be available. While the names of the companies working with Intel to produce end-user products are still under wraps, you can expect to see announcements about that time.

The introduction of DVI heralds the beginning of an age of truly interactive audiovisual media. The demonstration programs, although impressive, only scratch the surface of what's possible. DVI's potential as a tool for marketing, teaching, entertainment, simulation, animation, and special effects is bound to keep creative minds busy for many years to come. ■

ACKNOWLEDGMENTS

Special thanks to Paula Zimmerman and the entire staff of Intel's Princeton Operation for their help in preparing this article. Thanks also to Arch Luther, formerly of the DVI group and author of Digital Video in the PC Environment (McGraw-Hill, 1989).

L. Brett Glass is a freelance programmer, author, and hardware designer residing in Palo Alto, California. He can be reached on BIX as "glass."

Your questions and comments are welcome. Write to: Editor, BYTE, One Phoenix Mill Lane, Peterborough, NH 03458.

ChiWriter

Powerful Scientific/Multifont Word Processing at a Reasonable Price

How are you currently producing your scientific documents? Are you using a "golf ball" style typewriter? A regular word processor, hand lettering the special symbols? Are you fighting against a "what-you-see-is-definitely-not-what-you-get" system with a special command language? Or are you using one of our competitors' expensive and inflexible programs? Find out how ChiWriter can solve your scientific word processing problems.

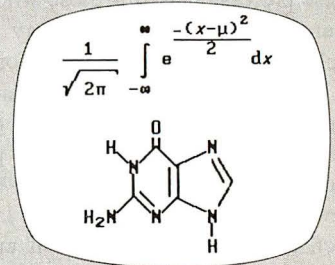

From an actual ChiWriter screen display

ChiWriter is a complete word processor, designed especially for scientific and foreign language text. Its features include: intuitive formula editing commands, automatic pagination, variable headers and footers, footnotes, box draw mode, a notepad window, and an integrated spelling checker.

Best of all, ChiWriter is completely "what-you-see-is-what-you-get." Even complicated formulas can be entered easily because the screen display corresponds exactly to the printout.

ChiWriter runs on IBM PC compatibles with 2 floppy disks or a hard disk, 384K RAM and CGA, Hercules, EGA, VGA or AT&T graphics. Support for all popular dot-matrix printers is included. The Laser Printer Support is required for HP LaserJet, DeskJet and PostScript printers.

In Short: An easy-to-use WYSIWYG package with powerful scientific/multifont word processing at a bargain price.

PC Magazine, July 1988

- | | |
|---|--|
| <input type="checkbox"/> ChiWriter Program | \$149.95 |
| <input type="checkbox"/> Laser Printer Support | \$74.95 |
| <input type="checkbox"/> WordStar/WordPerfect Converter | \$59.95 |
| <input type="checkbox"/> Chemistry Font Set | \$59.95 |
| <input type="checkbox"/> Russian Font Set | \$29.95 |
| <input type="checkbox"/> ChiWriter Deluxe (all of the above) | \$299.95 |
| <input type="checkbox"/> Conographic Font Set | \$149.95 |
| <input type="checkbox"/> MergeChi Mail Merge Program | \$29.95 |
| <input type="checkbox"/> IndexChi Index Generator | \$59.95 |
| <input type="checkbox"/> Check here for 20% educational discount (school and university teachers and students only) | |
| <input type="checkbox"/> Shipping & handling | \$ |
| | \$5 U.S. & Canada, \$10 Europe, \$15 elsewhere |

Name _____
Address _____
City _____
State _____ Zip _____ Country _____
Phone () _____
Payment by Check Purchase Order VISA MC
Card # _____ Exp. / _____

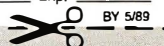

Horstmann Software Design Corporation
140 E. San Carlos St./P.O. Box 5039
San Jose, CA 95150-5039, USA
(408) 298-0828, FAX (408) 298-6157



horstmann software

June PC EXPO: Industry's Most Important Show

Trade event reflects strong, expanding microcomputer industry

Today's microcomputers are more and more powerful and sophisticated. So, too, are the professionals who use, buy, sell, manage, and plan exactly how to make these computers integral and productive parts of their businesses. For these professionals--for those who have come to be known as volume buyers--there is one great way to stay on top of the explosion in microcomputer technology: PC EXPO in New York.

For volume buyers, the 7th Annual PC EXPO in New York, June 20-22, at the Jacob Javits Center, is one of the best opportunities of the year to see hundreds of new and improved products from a who's who in the computer industry. Over 500 exhibitors--from established powerhouses to emerging newcomers--are displaying their latest state-of-the-art products and services. In fact, it's safe to say that if it automates, expedites or integrates corporate America, you'll find it at PC EXPO.

500 Firms Exhibiting at PC EXPO

Hundreds of vendors--from established powerhouses to emerging newcomers--are exhibiting at the 7th Annual PC EXPO in New York, June 20-22, 1989 at the Javits Convention Center. In an effort to reach tens of thousands of volume buyers coming from 50 states and abroad, companies like IBM, Hewlett-Packard, DEC, Compaq, 3Com, MicroSoft and Unisys will be previewing their newest state-of-the-art products. These and scores of other companies are expected to make over 200 new product introductions at the show.

Virtually every segment of the micro-computer and micro-related industry is represented at PC EXPO. Computer professionals will be able to engage in a wide array of hands-on product evaluations concerning networking and systems integration, of hardware platforms, and an extraordinary range of software.

The extraordinary breadth and depth of the PC EXPO exhibitor list confirms the show's stature as "the industry standard." Martin Hansen, MIS director for an international financial investment firm, sums up the expectations of

the show's 50,000 volume buyers, "I know if it's something I need to see, I can see it at PC EXPO," he says. "And if it's not at PC EXPO, I probably don't need to see it."

PC EXPO is open to business and trade professionals only from 10:00 to 5:00 Tuesday through Thursday, June 20-22, 1989.

Trade show offers outstanding educational opportunity

Guided and overseen by an experienced and elite Advisory Board, the world renowned PC EXPO Seminar Series is shaping up as an unmatched educational opportunity for the show's volume buying attendees. The Series--consistently rated the tops in the industry--offers 48 sessions and runs concurrently with the exhibits portion of the show on June 20-22, 1989.

The Series is highlighted by *Connections 89--13* special connectivity and networking seminars--and a new *Mac Track* exploring integration, technical and application development challenges concerning the Macintosh.

Kicking off the conference program is David House, senior vice president, Intel Corp, who is delivering the PC EXPO Keynote Address. Mr. House's address is scheduled for 9:15 a.m., Tuesday, June 20.



The PC EXPO show floor: A veritable who's who in the computer industry.

Early registration advised

Because of long lines anticipated for on-site registrations, volume buyer attendees are urged to plan their visit early. A registration brochure may be obtained by calling (201)-569-8542 or writing to PC EXPO at 385 Sylvan Avenue, Englewood Cliffs, NJ 07632.



Part 1

DIRECTORY ASSISTANCE

The directory:
the single most
important data structure
in your computer

You've heard it called many names—most often, the *directory*. Die-hard Apple II users usually call it the *catalog*. In Unix camps, the term is more likely *filesystem* or *filestore*. It's an organic entity whose internals are forever falling into disorder and fouling things up.

Its inner parts get corrupted: "Your FAT's been corrupted," the in-house computer whiz tells you, and you wonder if you should modify your diet. Or you're walking past a couple of the system managers for your company's Unix network and one remarks that he's "running out of i-nodes," and you think you should stop and recommend your family's physician.

Whatever you call it, it's the data structure on your disk (hard or floppy) that holds your files in its care. And whether you're aware of it or not, the directory (I'll settle on "directory" for the remainder of this article) is possibly the single most important data structure in your computer system. Its inefficiencies hamper your operations, its limitations set the boundaries on your disk-storage real estate, and its death marks the end of your workday. Your directory is your constant companion; it's a good idea to acquaint yourself with this company.

In this two-part discussion, I'll take a close look at the directory structure of some of the most popular microcomputer-based operating systems. I'll discuss the directories according to their family line, level of complexity (loosely defined, I'll admit), and the order in which they're introduced. I'll begin with DOS 3.3.

DOS 3.3

First, don't confuse this DOS 3.3 with the DOS 3.3 for the IBM PC; I'm discussing Apple's DOS 3.3 for the Apple II line. Although it was first released in August 1980, DOS 3.3 is still very much alive today. Many entertainment and educational packages are still released on DOS 3.3-formatted disks (or at least DOS 3.3 variants; software developers generate variants of DOS 3.3 that have been modified to be copy-protected).

The prevailing mass storage device for DOS 3.3 is the famous Apple Disk II. This drive supports a 5¼-inch floppy disk, single-sided, with 35 tracks of 16 sectors. Each sector holds 256 bytes of data. Consequently, a single Disk II disk can hold about 144K bytes of information. The actual space available to files is somewhat less, thanks to the sectors given over to the boot image and the directory.

Apple placed the disk's directory information at track 17, smack in the middle of the floppy disk. At first glance—and if a Disk II were all DOS would ever be used on—this makes perfect sense. Since you can assume that a disk's directory will be accessed more than any other section of the drive, placing the directory in the middle keeps the average head movement to a minimum. However, if you want to use DOS 3.3 on something other than a 35-track drive and you want to keep things optimal, you're faced with having to modify the operating system to alter its procedure for allocating directory sectors.

The format of DOS 3.3's primary catalog structure is shown in table 1. This is known as the volume table of contents (VTOC). An appropriate name: It is the table of contents (where the system goes first to look for requested files) for the volume (the contents of the disk).

In DOS 3.3, the VTOC has three jobs:

1. It holds the pointer to the volume's catalog—where the actual filenames and

their associated information are kept.

2. It contains data that defines the structure of the disk: how many tracks it has, the number of sectors per track, the number of bytes per sector, and so on. This allows you to create a DOS 3.3 volume on a non-Disk II drive, because DOS 3.3 can deduce the drive's structure from this information.

3. It carries the volume's bit map. This is a block of 200 bytes whose contents indicate the status of every sector on the volume. Each bit in the bit map corresponds to a sector on the volume. If that bit is a 1, its corresponding sector is available for use; if the bit is a 0, the sector has been claimed by some file (or, possibly, by DOS itself as a sector used to hold directory information).

The catalog (see table 2) is a singly linked list of sectors pointed to by the VTOC. Each sector holds information for up to seven files. Notice that there's no mention of subdirectories, or even directories. There are none—DOS 3.3 is a "flat" file system.

Within each file entry of the catalog, you'll find space for the filename (a generous 30 characters), the file type (whether the file is an Applesoft BASIC file, a text file, and so on), and a pointer to yet another singly linked list: the file's track/sector list (T/S list).

The T/S list keeps track of where the file's pieces are. Since it is unlikely that you have large amounts of contiguous space always available on the volume, the first sector of a file may be on one track, the next near the middle of the disk, and the next out on the other end of the disk. The T/S list is the system's index to where the file's components have been placed.

I've shown the layout of a T/S list sector in table 3. Each T/S list entry can keep track of up to 122 file sectors, or about 31.5K bytes. To show you how everything fits together, in figure 1 I've

continued

diagrammed a road map of all the pointers DOS 3.3 has to follow to locate the sectors of an imaginary file named BOB.

Have you noticed the DOS 3.3 file-system's most distinguishing feature? Everything's a singly linked list (although you could argue that entries on the T/S list are tables). DOS 3.3 makes no attempt to maintain the filenames in any sorted fashion other than the order in which the files were created on the disk. This means that if you fill the volume

with lots of filenames, the system has to scan linearly through the catalog when responding to a request for a file. Also, each time a file grows another 31.5K bytes, the system must add another entry to that file's T/S list. The number of disk accesses for reading bytes increases toward the end of file.

To be sure, these delays become apparent only as the contents of a given volume grow. And given that a Disk II-formatted floppy disk can hold only up to

about 126,000 bytes of file data, it's rare that a catalog becomes so full or a file so long that any degradation becomes apparent. It's also true that the Disk II is not the world's fastest floppy disk drive system to begin with. For many applications, however, DOS 3.3 is entirely adequate.

But that isn't what Apple thought.

ProDOS

ProDOS appeared in January 1984 as a replacement for Apple's DOS. Strictly speaking, the version of ProDOS released was ProDOS 8, targeted for Apple's II+, IIe, and IIc machines. With the introduction of the IIGS, Apple released ProDOS 16 to take advantage of the 65816's internal 16-bit registers (among other things). However, ProDOS 8 and 16 use identical file-systems, and since that's what I'm discussing here, I'll simply refer to the operating system as ProDOS. As you'll see, ProDOS's directory structure was not an upgrade of the DOS directory structure—it was a complete redesign. (Historical note: The ProDOS directory structure is virtually identical to that of SOS, the operating system of Apple's ill-fated Apple III.)

One of the major differences between ProDOS and DOS 3.3 is in the way the two operating systems view a disk. Recall that DOS 3.3 sees any disk as tracks made up of sectors; DOS 3.3 locates a given sector by that sector's track/sector coordinates. (This may make you wonder how DOS 3.3 handles multiheaded drives. You have to trick it: I have an old Konan hard disk system on my Apple II that came with its own driver software for two-headed 5-megabyte hard disk drives. It maps all even-numbered tracks to head 0 and all odd-numbered tracks to head 1. So DOS tracks 0 and 1 are on cylinder 1, DOS tracks 2 and 3 are on cylinder 2, and so forth).

ProDOS, however, sees a disk as a collection of 512-byte *blocks*, starting with block 0 and continuing on up to the number of blocks that are on the drive. Consequently, ProDOS is much more flexible; it isn't concerned with the physical geometry of the disk—tracks, sectors, and heads. That's left up to disk driver routines. And ProDOS provides well-defined "hooks" for attaching your disk driver routines to the operating system.

Another improvement is the added sophistication of ProDOS's directory structure. Often, added complexity can translate to added headaches; in this case, thankfully, the added sophistication buys increased performance. Where the DOS directory structure was a singly

Table 1: *The VTOC (volume table of contents), always located at the start of track 17 on an Apple DOS 3.3 disk.*

| VTOC format | |
|-------------|--|
| Byte offset | Description |
| 0 | Unused. |
| 1 | First catalog sector's track (byte). |
| 2 | First catalog sector's sector (byte). |
| 3 | Release version of DOS. |
| 4-5 | Unused. |
| 6 | Volume number (byte). |
| 7-38 | Unused. |
| 39 | Number of T/S pairs in a T/S list sector—equals 122 for a Disk II disk (byte). |
| 40-47 | Unused. |
| 48 | Last allocated track (byte). |
| 49 | Track allocation direction (byte). |
| 50-51 | Unused. |
| 52 | Number of tracks per disk (byte). |
| 53 | Number of sectors per track (byte). |
| 54-55 | Number of bytes per sector (word). |
| 56-59 | Bit map for track 0 (4 bytes). |
| 60-255 | Rest of bit map—4 bytes per track. |

Table 2: *DOS 3.3's catalog sector, a singly linked list of sectors pointed to by the VTOC.*

| Catalog format | |
|----------------|--|
| Byte offset | Description |
| 0 | Unused. |
| 1 | Next catalog sector's track (byte). |
| 2 | Next catalog sector's sector (byte). |
| 3-10 | Unused. |
| 11 | First file entry. Track number of first sector on this file's T/S list (byte). If 0, this entry is empty. |
| 12 | Sector number of first sector on this file's T/S list (byte). |
| 13 | File type and lock flag (byte). If highest bit is set, the file is locked (cannot be deleted). Some of the more common file types are: 0 = Text file 1 = Integer BASIC file 2 = Applesoft BASIC file 4 = Binary file |
| 14-43 | File name (30 bytes). |
| 44-45 | Length of file in sectors (word). |
| 46-80 | Second file entry (35 bytes). |
| 81-255 | Remaining file entries; 3 through 7 (35 bytes each). |

linked list, the ProDOS structure is doubly linked. Table 4 shows the format of a ProDOS directory block, and figure 2 gives a graphical view of how the structure works. Can you see the added component? And yes, ProDOS allows sub-directories.

In ProDOS, the VTOC is replaced by the volume directory key block, always found on block 2 of the device. The volume header of the key block carries in-

formation that you've already seen in DOS 3.3, such as the volume name (rather than just a number), the number of entries, and the block number of the bit map. But it also carries information that you didn't see in DOS 3.3, such as creation date and time information, and access permissions (e.g., read, write, and format). The improvements continue: For example, one bit in the access-privi-

continued

Table 3: Format of a sector from the track/sector list. This is how DOS 3.3 knows where the scattered parts of a file are.

| T/S list sector | |
|-----------------|--|
| Byte offset | Description |
| 0 | Unused. |
| 1 | Next T/S list entry's track(byte); 0 if no more entries. |
| 2 | Next T/S list entry's sector (byte). |
| 3-4 | Unused. |
| 5-6 | Physical-to-logical sector mapping word. The first sector pointed to at offset 12 maps to this logical sector in the file. |
| 7-11 | Unused. |
| 12-13 | Track(byte at 12) and sector (byte at 13) of file's first data sector. If this pointer is 0, it is assumed empty. |
| 14-15 | Track/sector of second data sector. |
| 16-255 | 120 more track/sector pointers. |

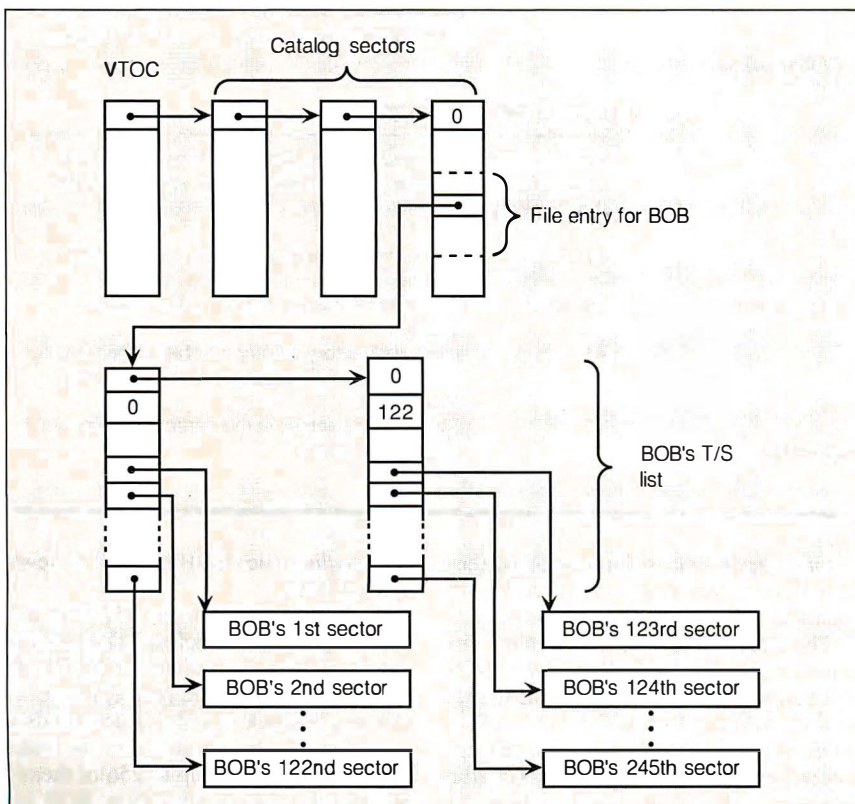

Figure 1: On the trail of file BOB. DOS 3.3 begins with the VTOC, searches through the catalog sectors, and then goes on through the track/sector list sectors.

Computers For The Blind

Talking computers give blind and visually impaired people access to electronic information. The question is how and how much?

The answers can be found in "The Second Beginner's Guide to Personal Computers for the Blind and Visually Impaired" published by the National Braille Press. This comprehensive book contains a Buyer's Guide to talking microcomputers and large print display processors. More importantly it includes reviews, written by blind users, of software that works with speech.

This invaluable resource book offers details on training programs in computer applications for the blind, and other useful information on how to buy and use special equipment.

Send orders to:
National Braille Press Inc.
88 St. Stephen Street
Boston, MA 02115
(617) 266-6160

\$12.95 for braille or cassette, \$14.95 for print. (\$3 extra for UPS shipping)
NBP is a nonprofit braille printing and publishing house.

Table 4: (a) The ProDOS directory block. Specifically, this is the format for the volume directory key block, whose first entry holds information pertaining to the entire disk (volume). (b) Fields different for a subdirectory key header's entry.

ProDOS directory block

| (a) Byte offset | Description | Byte offset | Description |
|-----------------|---|------------------------|---|
| 0-1 | Previous block pointer (word). | 60-61 | Tree pointer (word); points to the file's index tree. If this entry is a subdirectory, this is the first block of the subdirectory's catalog. |
| 2-3 | Next block pointer (word). | 62-63 | Total number of blocks used by the file, including index blocks (word). If this entry is a subdirectory, this is the number of blocks in the subdirectory's catalog. |
| 4 | Type and name length (byte). The high nibble indicates what type of entry this is. The low nibble is the length of the entry's name. | 64-65 | Creation date and time (4 bytes). |
| 5-19 | Volume name (15 bytes). | 66 | ProDOS version (1 byte). |
| 20-27 | Unused. | 67 | Minimum ProDOS version that can access this entry (1 byte). |
| 28-31 | Creation data/time (4 bytes). | 68 | Access privileges (1 byte). Bit 0 = File may be read. Bit 1 = File may be written. Bit 5 = File has been modified since last backup. Bit 6 = File may be renamed. Bit 7 = File may be destroyed. |
| 32 | ProDOS version number (1 byte). | 69-70 | Auxiliary field (word). This field depends on the entry type. For text files, this holds the record length. For binary files, this holds the load address. |
| 33 | Minimum version of ProDOS that can access this volume (1 byte). | 71-74 | Date and time when the file was last modified (4 bytes). |
| 34 | Access privileges (1 byte). Bit 0 = Volume may be read. Bit 1 = Volume may be written. Bit 5 = Volume's directory has been modified since last backup. Bit 6 = Volume may be renamed. Bit 7 = Volume may be destroyed. | 75-76 | Block number of this file's directory (word). |
| 35 | Length of each file entry in the volume table, usually set to 39 (1 byte). | 77-511 | Remaining file entries. For the volume key block, there is room for 11 more entries; for all other blocks, there is room for 12 more entries. |
| 36 | Number of entries in each volume block, usually set to 13 (1 byte). | | |
| 37-38 | Number of active entries in the volume table; includes subdirectories, but does not include the header (word). | | |
| 39-40 | Starting block of volume bit map (word). | | |
| 41-42 | Total number of blocks on this volume (word). | | |
| 43 | First file entry. Type and name length (byte). High nibble is entry type; low nibble is name length. 0 = Delete entry. 1 = Seedling file. 2 = Sapling file. 3 = Tree file. D = Subdirectory file. E = Subdirectory header entry. F = Volume header entry. | (b) Byte offset | Description |
| 44-58 | Entry name | 37-38 | Number of active entries in the subdirectory (word). |
| 59 | File type (1 byte). Some of the more common types are: 1 = Bad blocks file 2 = Text file 3 = Binary file 25-27 = Appleworks files 252 = Applesoft BASIC program file 255 = ProDOS system file | 39-40 | Pointer to the parent directory's key block (word). |
| | | 41 | This subdirectory's entry number in the parent directory (byte). The parent directory's entry counts as 0. |
| | | 42 | The length of entries in the parent directory—usually 27h (byte). |

leges byte can be used by disk backup software to determine whether or not the volume has been modified since the last backup.

Following the volume header on the key block—and on the remaining blocks of the directory chain—are the file and subdirectory entries. Though shorter, these entries are similar to the volume header entry: They carry creation date and time, access flags, and modification date and time (a must for software development using a make utility). A subdi-

rectory entry points to the head of a directory list whose structure is virtually identical to the master directory list.

The structure of files is also much improved under ProDOS. Recall that DOS 3.3 keeps track of a file's physical sectors via a singly linked T/S list. In ProDOS, the structure of a file's housekeeping information actually changes as the file grows. If you look back at figure 2, you'll see that I've shown a 1-block file named BOB as a member of the master directory. In ProDOS terminology, BOB

is a *seedling* file; BOB has 512 or fewer bytes of data.

As BOB grows past the 512-byte barrier, it becomes a "sapling" file (see figure 3). Where the pointer in BOB's directory entry (the tree pointer) once led to a single block of data, it now leads to an index block. Pointers in the index block—there can be up to 256 of them—point to the data blocks. Now BOB can hold up to 128K bytes of data.

If BOB continues to grow past 128K

continued

Power

Incredible Value!

Don't take our word for it, take theirs...

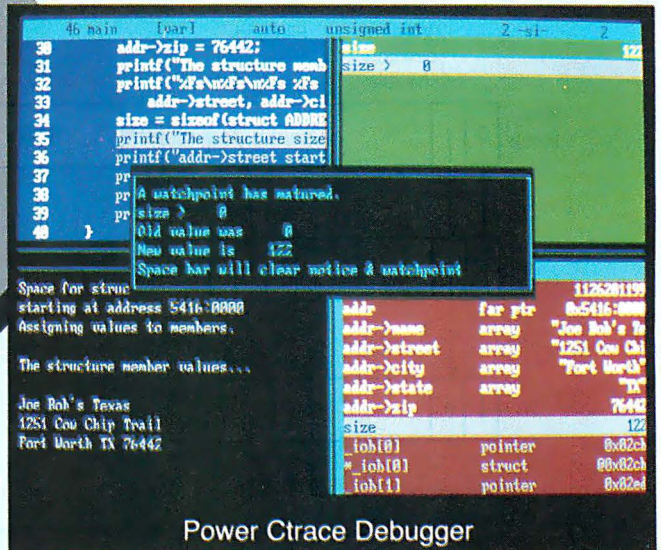

Power C Trace Debugger

"Do you know what the underground bargain C compiler of this year is? It's the Mix Power C compiler. For under \$25 with shipping, it is one heck of a good compiler."

Victor Schneider
Dr. Dobb's Journal, June 88 (Letter to the editor)

"Overall, Power C's performance is remarkable for the price. Quite compatible with the Microsoft C and Turbo C "standards", Power C is a heavyweight contender in the educational, hobbyist, and perhaps even the professional market — at a bantamweight price."

Stephen Davis
PC Magazine, September 13, 88 (Review)

"Power C is an unbelievable product for \$19.95, and is very competitive with Turbo C, Microsoft C, and Microsoft's new Quick C in both features and performance. It is excellent for the beginner who wants to learn C, or for the experienced programmer who wants to develop professional applications. The manual alone is worth the price of this package, and the generous library source code and assembler offer adds to the value of it. If you have any desire to program in C, or want a more powerful C compiler, get a copy of Power C!"

Michael Cortese
Computer Shopper, August 88 (Review)

"The Ctrace debugger is where Mix really shines. It is magnificent. It's not only better than the stripped down debugger Microsoft includes with Quick C, it's better than the full debugger Microsoft provides with its high-end compiler (Codeview)."

David Weinberger
Computer Shopper, November 88 (Review)

Circle 183 on Reader Service Card

Technical Specifications

Power C includes: Power C compiler with integrated Make, Power C Linker, Power C Libraries (450 functions), the Power C book (680 pages), and support for...

- ANSI standard
- IEEE floating point
- 8087/80287 coprocessor
- auto-sensing of 8087/80287
- automatic register variables
- unlimited program size
- mixed model (near & far pointers)
- graphics on CGA, EGA, VGA, & Hercules

Optional Products:

- Power Ctrace debugger
- Library source code
- BCD business math

Order now by calling our toll free number or mail the coupon to Mix Software, 1132 Commerce Drive, Richardson, TX 75081.

1-800-333-0330

For technical support call: 1-214-783-6001

Minimum System Requirements:
DOS 2.0 or later, 320K memory, 2 floppy drives or hard drive.
Runs on IBM PC, XT, AT, PS/2 and compatibles.

60 day money back guarantee

Name _____
Street _____
City _____
State _____ Zip _____
Telephone _____
Paying by: Money Order Check
 Visa MC AX Discover
Card # _____
Card Expiration Date _____
Computer Name _____ Disk Size _____
 5 1/4" 3 1/2"

Product(s) (Not Copy Protected)

| | |
|--|----------|
| <input type="checkbox"/> Power C compiler (\$19.95) | \$ _____ |
| <input type="checkbox"/> Power Ctrace debugger (\$19.95) | \$ _____ |
| <input type="checkbox"/> Library Source Code (\$10.00) (includes assembler & library manager) | \$ _____ |
| <input type="checkbox"/> BCD Business Math (\$10.00) | \$ _____ |
| Add Shipping (\$5 USA - \$20 Foreign) | \$ _____ |
| Texas Residents add 8% Sales Tax | \$ _____ |
| Total amount of your order | \$ _____ |

B

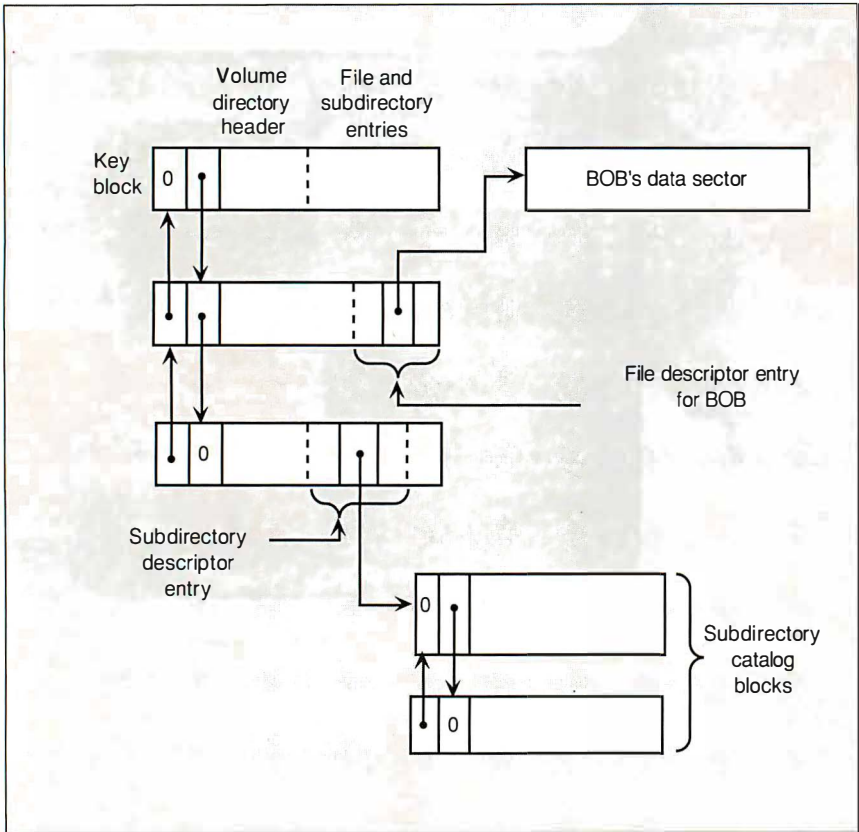

Figure 2: The ProDOS directory structure. Notice that lists are doubly linked. (Not shown is the subdirectory's return link to its father's key block.)

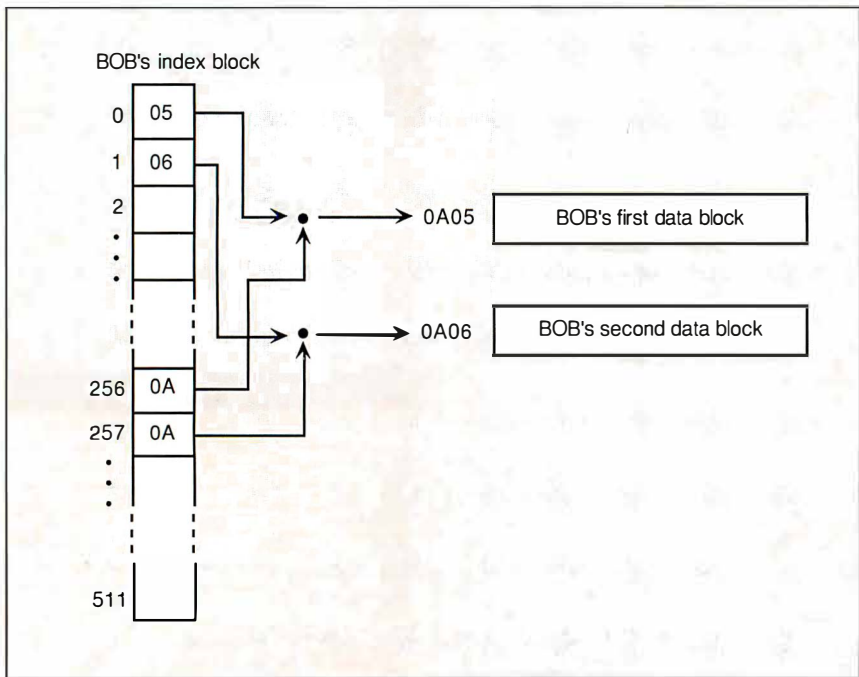

Figure 3: Structure of a ProDOS sapling file. The pointer in BOB's directory entry now leads to an index block. Notice that the word-wide block number of BOB's data blocks is formed by concatenating low and high bytes from opposite halves of the index block.

bytes, the file adds another index level and becomes a *tree* file (see figure 4). Now BOB's tree pointer leads to a master index block, whose elements point to index blocks, whose elements (finally) point to the actual data. A tree file can contain up to 16 megabytes of data, and this is as big as a file can get under ProDOS.

The beauty of this file structure is that small files are rapidly accessed, but large files are still taken into account. Plus, even though a file may grow to 16 megabytes, you need at most three disk accesses to retrieve the file's data. Compare this with the singly linked list index structure of DOS 3.3, and you can see the advantages. The ProDOS directory structure is quite respectable in its capabilities, and you'll see that it shares some similarities with the file-systems of larger machines that I'll cover later.

CP/M

In 1979, Digital Research released version 2 of the CP/M operating system. CP/M 2's offspring—CP/M 2.2—followed shortly thereafter and became the premier operating system for the popular 8080- and Z80-based S-100 bus systems. CP/M still enjoys a substantial following, and if imitation is the sincerest form of flattery, then CP/M should be rosycheked: The first version of PC-DOS was more or less a port of CP/M to the 8088 processor.

The good news about the CP/M file system is its adaptability: It can accommodate everything from 5 1/4-inch single-sided floppy disks to (conceivably) hard disks as big as a gigabyte. The bad news is that this adaptability often demands some complex calculations on the part of some unlucky human—usually whoever gets to install CP/M on a new system.

Space on a CP/M drive is divided into allocation blocks. Files grow in allocation-block-size jumps. Like the ProDOS block, a CP/M allocation block is composed of a number of physical disk sectors. Unlike the ProDOS block, a CP/M allocation block is not the same size for all CP/M disks. Here's where CP/M's flexibility comes in: You can select the optimum allocation block size for your particular disk drive. The data structure within CP/M that describes the geometry of a disk is the disk parameter block (DPB) shown in table 5. Choosing the values for the DPB entries is not a matter of solving a single equation; rather, it involves—as you'll soon see—a trade-off between how many files you anticipate having on your disk and the average size of each file.

From an application's point of view, the CP/M file-system is record-based. Any program will see a file as a collection of 128-byte records. This is a hold-over from CP/M's early days, when the physical sector size for a CP/M disk was 128 bytes. Often, you'll hear this referred to as a *standard record*; if you're talking about CP/M, it means 128 bytes. The DPB carries the information needed to calculate the number of standard records per allocation block.

Unlike the Apple-based file-systems I've covered so far, the CP/M directory structure is unlinked. Rather, a disk's directory is kept on a series of contiguous allocation blocks beginning at a specific track on the disk. The location of this starting track of the directory is defined in the DPB as an offset from track 0. This allows you to reserve space for boot tracks on the disk, since allocation blocks that files use for their contents *follow* the directory on the disk.

A contiguous, unlinked directory has advantages and disadvantages. Being contiguous, the records of the directory can be rapidly accessed. However, the number of blocks allocated to the directory is fixed; if you've allotted eight allocation blocks to the directory, it'll take up eight allocation blocks even if there's only one file on the whole disk.

Each standard record of the directory can hold up to four entries (see table 6). Within each entry are fields for the file's name, type, and data map. The data map is a set of pointers that lead you to where the various parts of the file's data are stored. Each pointer references an allocation block, and, depending on the configuration of the disk, each pointer may be 1 or 2 bytes long. If a disk is composed of less than 256 allocation blocks, pointers are byte-wide; word-wide pointers allow CP/M to access disks holding up to 65,535 allocation blocks. Consequently, each directory entry points to a maximum of either 8 or 16 allocation blocks of file data.

Once a file grows so big that a single entry cannot keep track of it, CP/M opens an extent entry. This is a directory entry identical to the first except for the extent byte and the contents of the data map. I've diagrammed the mechanics of this in figure 5. In the figure, the file BOB has grown so that one data map isn't enough. The operating system creates another entry in the directory with the extent byte set to 1. This entry's data map points to BOB's additional allocation blocks. If BOB continues to grow, CP/M will create more and more extents,

continued

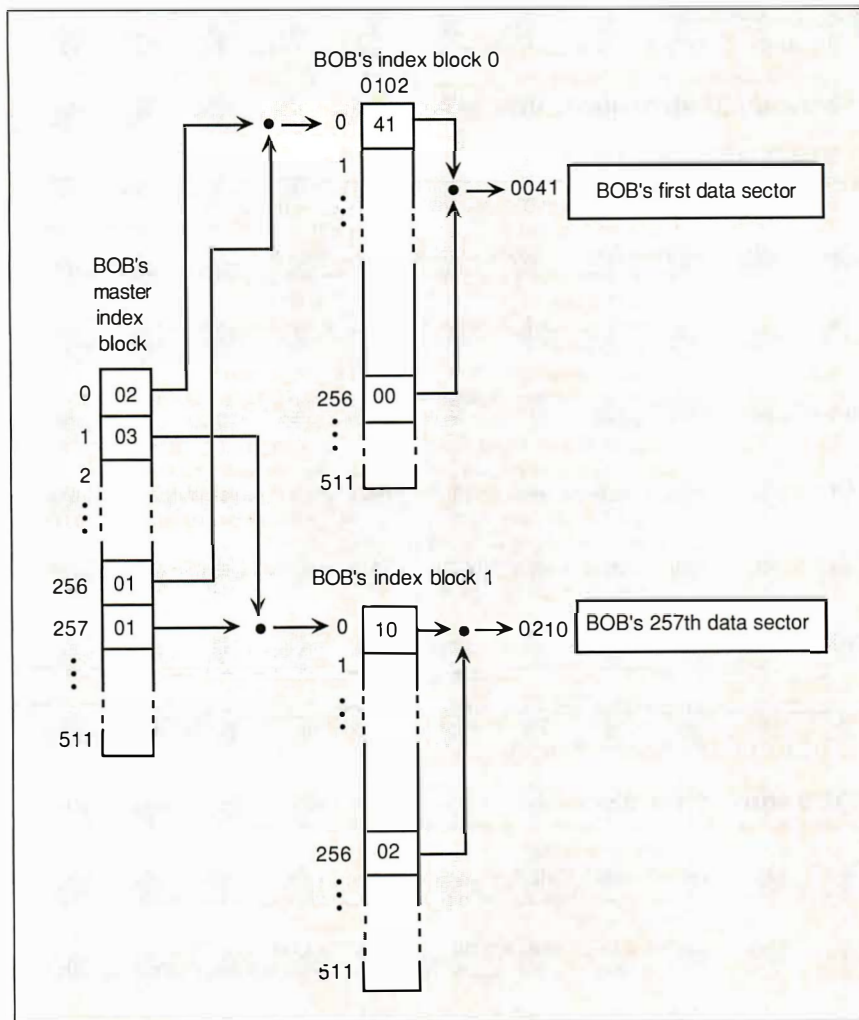

Figure 4: BOB has become a tree file. Now there are two levels of index blocks.

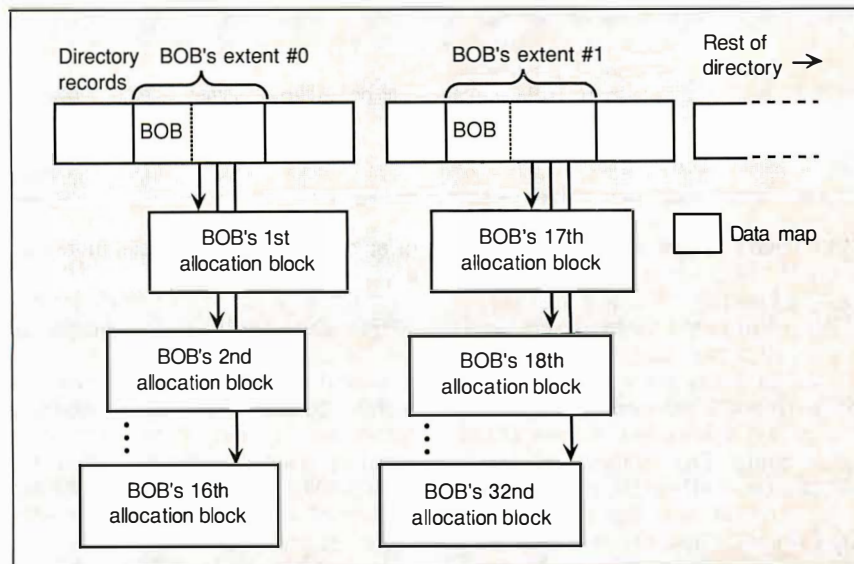

Figure 5: BOB moves to CP/M. Note that the size of a single allocation block differs from disk to disk and may contain more than one 128-byte record.

Table 5: CP/M's disk parameter block. This data structure (kept in memory) enables the operating system to determine the physical parameters of the disk and map logical records to physical disk sectors.

| Byte offset | Description |
|-------------|--|
| 0-1 | Number of 128-byte records per disk track (word). |
| 2 | Block shift factor (byte). Number of times a record number must be shifted right to get its allocation block number. |
| 3 | Block mask (byte). Perform an AND on this byte with a record number to get that record's offset within its allocation block. |
| 4 | Extent mask (byte). Allows you to calculate physical extent from logical record number. |
| 5-6 | Highest allocation block number on the drive (word). |
| 7-8 | Maximum number of directory entries (word). Note that the first entry is number 0. |
| 9-10 | Initial 16 bits of allocation vector (word). Used to preallocate directory blocks when the system creates the allocation vector bit map. |
| 11-12 | Size of check area (word). The check area is a region of hash bytes that enable CP/M to determine that a disk has been swapped. This region usually has 1 byte per 128 bytes of directory. |
| 13-14 | Initial offset (word). Number of tracks reserved (starting at track 0) for boot or partitioning information. |

Table 6: A CP/M directory entry.

| Byte offset | Description |
|-------------|--|
| 0 | User code (byte). |
| 1-8 | Filename (8 bytes). |
| 9-11 | File type (3 bytes). The high bit of each of these bytes is reserved as an attribute bit. Byte offset 9; the high bit set represents a read-only file. Byte offset 10; the high bit set represents a system file (not displayed by DIR). Byte offset 11; the high bit set represents a change in this entry (for archive purposes). |
| 12 | Extent number (byte). |
| 13 | Used by BDOS (byte). |
| 14 | Extent overflow (byte). |
| 15 | Record count (byte). Indicates the number of 128-byte records described by this entry. |
| 16-31 | Data map. This field can either be 16 1-byte entries or eight 2-byte entries (see text). |

up to a maximum of 32. (Some releases of CP/M allow for more extents, using the extent overflow byte at offset 14.)

Here's where the tricky part of determining allocation block size comes in. Given that files grow by allocation-block-size leaps, you can assume that, on average, half a file's last allocation block will be empty. This might prompt you to choose a small allocation block size, but to do so would mean that as a file grew larger the system would have to create a multitude of extent entries in the directory for the file. Worse, there's really no mechanism for ensuring that extent entries are stored in ascending order in the

directory; more extents mean more disk accesses.

You may notice that a CP/M disk has no bit map. Actually, there is an allocation bit map—called the *allocation vector*—but it isn't kept on the disk drive, it's kept in memory. Whenever the operating system selects a disk, it reads the entire directory to construct the allocation vector in RAM. Of course, as files grow and are deleted, the system updates the allocation vector appropriately.

At first glance, the CP/M directory structure may appear flat. This is partially true; you can't create subdirectories, but you can set up alternate directo-

ries on the same disk via the *user code* (at byte offset 0 in each file entry). This byte can take on values ranging from 0 (default) to 31 and thereby serves to partition the files in the directory into 32 "user areas." You move from area to area with the USER command. So, if you enter USER 4, you can see and manipulate only files with user codes set to 4.

Any discussion of CP/M would be incomplete without mentioning ZCPR3, a kind of extension to the CP/M operating system. A full-blown ZCPR3 package includes numerous program tools, but it is germane to point out here ZCPR3's ability to support named directories.

Essentially, ZCPR3 allows you to attach a name to a specific drive and user number, so A15: (drive A, user area 15) might be ROOT, and A7: might be WORDS. You can move through directories using a Unix-like CD (change directory) command, and with some clever programming you can even create the illusion of hierarchical directories. Although at the lowest level the operating system sees a CP/M directory structure, ZCPR3 makes you feel as though you're working with a more sophisticated file-system.

Next Month

I'll continue the promenade through microcomputer file-systems, moving on to MS-DOS, the Macintosh, and Unix. You may be surprised at some of the similarities between what I've covered so far and what you'll see next month. ■

BIBLIOGRAPHY

- Apple Computer. *Apple IIGS ProDOS 16 Reference*. Reading, MA: Addison-Wesley, 1987.
- Conn, Richard. *ZCPR3: The Manual*. New York: New York Zoetrope, 1985.
- Cortesi, David E. *Inside CP/M: A Guide for Users and Programmers*. New York: Holt, Rinehart, and Winston, 1982.
- Worth, Don, and Pieter Lechner. *Beneath Apple DOS*. Chatsworth, CA: Quality Software, 1981.
- Worth, Don, and Pieter Lechner. *Beneath Apple ProDOS*. Chatsworth, CA: Quality Software, 1984.

Rick Grehan is the director of the BYTE Lab. He has a B.S. in physics and applied mathematics and an M.S. in computer science/mathematics from Memphis State University. He can be reached on BIX as "rick_g."

Your questions and comments are welcome. Write to: Editor, BYTE, One Phoenix Mill Lane, Peterborough, NH, 03458.

PRODUCT SHOWCASE

■ BUYER'S MART

■ BYTE BITS

■ PRODUCT SPOTS

■ MICRO PRODUCT CENTER



THE BUYER'S MART

A Directory of Products and Services

THE BUYER'S MART is a monthly advertising section which enables readers to easily locate suppliers by product category. As a unique feature, each BUYER'S MART ad includes a Reader Service number to assist interested readers in requesting information from participating advertisers.

RATES: 1x—\$525 3x—\$500 6x—\$475 12x—\$425
Prepayment must accompany each insertion. VISA/MC Accepted.

AD FORMAT: Each ad will be designed and typeset by BYTE. Advertisers must

furnish typewritten copy. Ads can include headline (23 characters maximum), descriptive text (250 characters is recommended, but up to 350 characters can be accommodated), plus company name, address and telephone number. Do not send logos or camera-ready artwork.

DEADLINE: Ad copy is due approximately 2 months prior to issue date. For example: November issue closes on September 8. Send your copy and payment to THE BUYER'S MART, BYTE Magazine, 1 Phoenix Mill Lane, Peterborough, NH 03458. For more information call Brian Higgins at 603-924-3754.

ACCESSORIES

PRO-CLASSIC T-SHIRTS & BUTTONS

JUST SAY NO to expensive, incompatible PCs with a T-shirt or button! T-shirt is \$12.00 plus \$1.50 shipping & handling. Button is \$1.00 plus \$0.50 s&h. State size and quantity when ordering. Send check or money order to:

Advanced Systems Consultants

21115 Devonshire St. #329, Chatsworth, CA 91311

(Sorry, no VISA/MC. CA residents MUST add sales tax. We never cash your check until order is shipped!)

Inquiry 576.

ACCESSORIES

FREE CATALOG

A complete source for computer supplies at low prices, Fast Service: Diskettes • Latest Accessories

- Books • Software • Dust Covers • Furniture
- Data Cartridges • Plotter Pens • Cleaning Supplies
- Tapes • Ribbons • Printers • Computer Paper
- Copier Supplies • Surge Protectors • Cables
- Print Wheels • MUCH MORE!!!

Call, write or circle inquiry card for a FREE CATALOG

GAAN COMPUTER SUPPLIES

186 B East Sunnyoaks Ave., Campbell, CA 95060
(800) 523-1238, In Calif. (408) 370-6747

Inquiry 581.

ARTIFICIAL INTELLIGENCE

muLISP™ 87 for MS-DOS

Fast, compact, efficient LISP programming environment. muLISP programs run 2 to 3 times faster & take 1/2 to 1/3 the space of other LISPs. 450 Common LISP functions, multi-window editing & debugging, flavors, graphics primitives, lessons & help, demo programs, comprehensive manual.

Soft Warehouse, Inc.

3615 Harding Ave., Suite 505, Honolulu, HI 96816
(808) 734-5801

Inquiry 585.

CUT RIBBON COSTS!

Re-ink your printer ribbons quickly and easily. Do all cartridge ribbons with just one inker! For crisp, black professional print since 1982. You can choose from 3 models:

- Manual E-Zee Inker — \$39.50
- Electric E-Zee Inker — \$89.50
- Ink Master (Electric) — \$189.00

1000's of satisfied users in 5 years. Money back guarantee.

BORG INDUSTRIES

525 MAIN ST., JANESVILLE, IA 50647

1-800-553-2404 In IOWA 319-987-2976

Inquiry 577.

REFILL LASER PRINTER & COPIER CARTRIDGES

Don't throw away that used laser printer or copier cartridge. Refill it and save over 75%, it's easy. For use with Canon EP & EPS cartridges, HP LaserJet & LaserJet II, Apple Laserwriter & Laserwriter II, Canon LPB, FAX, and many others. Also kits for Canon Copiers.

COMPLETE REFILL KIT \$29.95

Includes toner, felt pad, and instructions.

VIDEO TAPE PROGRAM \$45.00

Shows disassembly, cleaning, and remanufacture.

MORACK INC.

8847 W. 87th St., Hickory Hills, IL 60457

For order or information (312) 598-0580

Inquiry 582.

BAR CODE

PRINT BAR CODES, BIG TEXT, LOGOS

On EPSON, IBM, OKI dot matrix or LaserJet. Design any format/size on ONE easy screen. 1-120 fields/label. 13 text sizes to 1" — readable at 50 ft. AIAG, MIL-STD. 2 of 5, I2B, UPC/EAN, Code 39. File Input, FAST—\$279. Logos, Product Symbols. Other menu-driven bar code programs from \$49. 30 day \$ back.

Worthington Data Solutions

417-A Ingalls St., Santa Cruz, CA 95060

(800) 345-4220 In CA: (408) 458-9938

ARTIFICIAL INTELLIGENCE

NATURAL LANGUAGE C LIBRARY

Increase your market share! Use JAKE to add a natural language front end to your application. JAKE translates English queries and commands into C function calls and data structures. JAKE offers context-sensitive semantic processing; interfaces easily; <64K mem.

JAKE \$495. INTERACTIVE DEMO \$10

ENGLISH KNOWLEDGE SYSTEMS, INC.

5525 Scotts Valley Dr. #22, Scotts Valley, CA 95066

(408) 438-6922

Inquiry 583.

SELF-INKING PRINTER RIBBON

Awarded United States Patent #4701062

Lasts 10-15 times longer than the conventional ribbon
For printers using 1/4" width open spool ribbon.

Ovidata 82A83A-84-92-93 Dec LA 180/120
Teletype-33, 35 Dec LA 30/IBM 1443
Star Gemini 10X Teletype-Model 40
Extel TI 800/810, 820, 880

Contact us by mail, phone or telex and we will forward you a brochure.

CONTROLLED PRINTOUT DEVICES, INC.

POB 869, Baldwin Rd., Arden, NC 28704

(704) 684-9044 • TELEX: (FILMON-AREN) 577454

Inquiry 578.

BAR CODE READERS

For PC, XT, AT, & PS/2, all clones, and any RS-232 terminal. Acts like 2nd keyboard, bar codes read as keyed data. With steel wand—\$399. Works with DOS, Xenix, Novell, Alloy, -ALL software. Lasers, magstripe, & slot badge readers. One year warranty. 30 day \$ back. Direct from USA manufacturer.

Worthington Data Solutions

417-A Ingalls St., Santa Cruz, CA 95060

(800) 345-4220 In CA: (408) 458-9938

COMPANION AND EXTENDER

Place a keyboard and monitor up to 600' from your CPU with EXTENDER and COMPANION products. Keep a second Keyboard/Monitor at the CPU with COMPANION. Supports MDA, CGA, EGA, VGA, PS2. Uses single 3/8" cable.

Prices start at \$149.00 for EXTENDER and \$219.00 for COMPANION 25 ft. unit complete.

CYBEX CORPORATION

2800-H Bob Wallace, Huntsville, AL 35805

205-534-0011 International Fax # 205-837-9212

Inquiry 579.

NanoLISP \$99.99

An MS-DOS Common LISP interpreter that supports most Common LISP operations and strictly adheres to the standard. Numerous advanced and extra features, excellent debugging facilities, sample AI programs, fully-indexed manual, free technical support.

Microcomputer Systems Consultants

P.O. Box 6646, Santa Barbara, CA 93160

(805) 967-2270

Inquiry 584.

PRINT BAR CODES/BIG TEXT FROM YOUR PROGRAM

Add bar codes and big graphics text to your program. Print from ANY MS-DOS language. Bar codes: UPC, EAN, 2 of 5, MSI, Code 39. Epson, OKI, IBM dot matrix text up to 1/2". LaserJet up to 2". Font cartridges not required. \$179-\$239. 30 day \$\$ back.

Worthington Data Solutions

417-A Ingalls St., Santa Cruz, CA 95060

(800) 345-4220 In CA: (408) 458-9938

RIBBONS•RIBBONS•RIBBONS

Professional, Fast, Friendly Service. Over 1,100 Printer & Typewriter Ribbons Available. One Call For All Your Ribbon Needs.

—THE RIBBON SOURCE—

SATISFACTION GUARANTEED!

San Diego, So. Cal. U.S.

(619) 259-8800 (800) 354-6688 (800) 453-7744

Inquiry 580.

Buy your own Book

Get a fully supported LISP program for the MAC without the padded price to pay for an expensive book. \$20 buys it MAC plus or equivalent runs it. Order now and save.

Oosson Software

Box 33113, Coon Rapids, MN 55433

Inquiry 584.

PORTABLE READER

Battery operated, handheld reader with 64K static RAM, 2x16 LCD display, 32 key keyboard, Real-Time-Clock. Wand or laser scanner. Program prompts and data checking thru its own keyboard. Easy data transfer by RS-232 port or PC, PS/2 keyboard. Direct from USA manufacturer. 30 day \$\$ back.

Worthington Data Solutions

417-A Ingalls St., Santa Cruz, CA 95060

(800) 345-4220 In CA: (408) 458-9938

THE BUYER'S MART

BAR CODE

BAR CODE SOFTWARE SOLUTIONS

ISD has software solutions that allow you to use bar codes for most anything. Like identifying products. Labeling packages. Or even managing assets and paperwork. You'll be able to speed and simplify data collection. Track products dock-to-stock. Streamline inventory control. And more.

Integrated Software Design, Inc.

171 Forbes Blvd., Mansfield, MA 02048
TEL: (508) 339-4928 FAX: (508) 339-2257
©1989 Integrated Software Design, Inc.

Inquiry 586.

BAR CODE SOLUTIONS

Bar coding is so easy with our complete line of readers. Our PC-Wand readers emulate your PC keyboard or ASCII terminal, and are carried around taking inventory, entering road sales and clocking time. Our bar code label printing software packages work with DOS and most matrix or laser printers. We also sell pre-printed labels. Our hardware can work with nearly every computer in the world.

International Technologies & Systems Corp.

635-C North Berry St., Brea, CA 92621
(714) 990-1880 FAX: 714 990-2503 TLX 6502824734 MCI

Inquiry 587.

BAR CODE MADE EASY

PERCON® EZ-READER™ keyboard interfaces and multiuser RS-232 models make it easy to add bar code to virtually any computer/terminal WITHOUT SOFTWARE MODIFICATION. Immediate shipping. Two year warranty. Bar code printing software available. Call for details on fast, accurate, easy data entry. Substantial reseller discounts.

PERCON®

2190 W. 11th St., Eugene, OR 97402

1-800-8 PERCON

PC BAR CODE SPECIALISTS

Bar code readers designed for fast, reliable, cost effective data entry. Looks just like keyboard data! Choose from stainless steel wand or laser interface. Also, powerful Bar Code and Text printing software. Great warranty. Dealer inquiries welcome.

Seagull Scientific Systems

15127 N.E. 24th, Suite 333, Redmond, WA 98052
206-451-8966

BAR CODING SOURCE CODE

UPC, EAN, CODE39, 2 of 5, and Codabar. Ready to run programs with source codes. Toolkit for 'C' programmers. Do barcodes from your own programs. Supports HP LJ and Epson printers. Includes disk, manual, and symbology documentation. No royalties. 30 day money back guarantee.

SymbBCG — \$79.00 Complete Symbollgc

17019 Jeanette Ave., P.O. Box 47498, Cerritos, CA 90703
(CA res. add \$4.81 tax) (213) 926-2823

Inquiry 588.

DATA INPUT DEVICES

Bar Code & Magnetic Stripe Readers for microcomputers & terminals, including IBM PS/2 & others, DEC, Macintosh, AT&T, CT, Wyse, Wang. All readers connect on the keyboard cable & are transparent to all software. Low cost bar code print programs, magnetic encoders, & portable readers are also available. GSA contract #GS00K67AGS5346.

TPS Electronics

4047 Transport, Palo Alto, CA 94303
415-856-6833 Telex 371-9097 TPS PLA
FAX: 415-856-3843

Inquiry 589.

BAR CODE

VARIANT MICROSYSTEMS BAR CODE READERS DELIVER

WAND/LASER/MAGNETIC CARD CONNECTIVITY
• Keyboard wedges (Internal/External) for IBM PC/XT/AT, PS2 and portables.

- RS232 wedges for WYSE, Link, Kimtron terminals
- Bar code and label printing software
- Full two year warranty
- 30 Day Money Back Guarantee
- Extensive VAR/Dealer Discounts

3140 De La Cruz Blvd., Suite 200/Santa Clara, CA 95054(408) 980-1880

Inquiry 590.

CAD/CAM

PHOTO PLOTTING

from your Smartwork Edit file or any RS-274 Gerber Photo Plot file. Raster type Photoplotting supplied on .D07" thick Kodak Ultraline film. Plot data accepted by modern, 5 1/4", 3 1/2" MS-DOS format disks or 9 track mag tape. Gerber plot file 8"x10" plots start from \$15.00.

Call for details.

KEPRO CIRCUIT SYSTEMS

Fenton, MO

1-800-325-3878 / 1-314-343-1630 in MO.

Inquiry 591.

P-C-B ARTWORK MADE EASY!

Create and Revise Printed-Circuit-Artwork on your IBM or Compatible
• Help Screens • Dip & Sip Library
• Printer and Plotter Artwork • Supports Mice
• Auto-Router available • ICON Menus
Requirements: IBM or Compatible PC, 384K RAM, DOS 3.0 or later. PCBoards: \$99.00 DEMO: \$10.00

PCBoards

2110 14th Ave. South, Birmingham, AL 35205
(205) 933-1122

Inquiry 592.

CALENDAR SCHEDULING

PC-CAL

• Versatile Calendar and Event Scheduler
• Personal and Group Scheduling • Familiar Displays • Simple Setup and Operation • Side by Side Viewing • Repeating Appointments
• Copy, Move, Modify, • Available for DOS, OS2, Xenix, HP3000 • Many useful Display and Printed Reports • DOS & OS2 for \$95

BRADFORD BUSINESS SYSTEMS

25301 Cabot Rd. #201, Laguna Hills, CA 92653
(714) 859-4428 FAX: 859-4508

Inquiry 593.

CASE

FINITE STATE PROGRAM COMPILERS

State programs develop quicker, run faster and use less memory than sequential programs. A few keystrokes can replace hundreds of instructions. The Compiler, a CASE software development tool, forms source state programs in: Ada, BASIC, C, FORTRAN and Pascal. FOR IBM DOS.

Price \$200 per. lang. (With Primer and Debugger)
Sampler \$50.00 (With all manuals & credit)

AYECO 5025 Nassau Circle, Orlando
INCORPORATED FL 32808 (407) 295-0930

Inquiry 594.

CATALOG

SOFTWARE RENTALS

60-days rentals commercial software: AutoCad R10 \$179, dBASE IV \$129, PageMaker 3.0 \$179, dBase 1.1 \$27, Dralix 1+2.0 \$50, MSWord 4.0 \$61, Symphony 2.0 \$61, Ventura 2.0 \$169, WordPerfect 5.0 \$77, Wordstar Pro 5 \$89, Enable 2.0 \$61, Clipper Sum \$7 \$39, Office Publisher 1.1 \$73, Quattro 1.0 \$30, Xenix V 2.1 \$121, Novell Adv2.0 \$299, and more 2000. All CAD, Desktop Publishing, Databases, Spreadsheets, Word Processors, Systems and Languages, Utilities. Send \$2 for catalog diskette. Check clearance required, with money order will be faster. All world rentals.

Technical Consulting Co. Inc.
4700 NW 7th St., Suite 359, Miami, FL 33126

Inquiry 595.

CD-ROM

CD-ROM Drives & Titles

Largest selection for PC & Mac.
Microsoft Programmers Library & Drive \$995
Computer Library \$695 • Public Domain S/W \$99.

Drives from \$699. Hundreds of titles from \$29.
MC/VISA/AMEX, Money-back Guarantee.
Call or write for free 100 page catalog.

Get it all from "The Bureau"

Bureau of Electronic Publishing

121 Norwood Ave., Upper Montclair, NJ 07043
(201) 746-3031

Inquiry 596.

Food/Analyst CD-ROM

Analyze foods, meals, and recipes for any number of persons based on the complete USDA food nutrient database. 4700+ foods, 80+ nutrients. See graphs, printed reports, summaries. Other titles and CD-ROM publishing services available.

Hopkins Technology

CD-ROM Publisher

421 Hazel Lane, Suite 104

Hopkins, MN 55343

(612) 931-9376 Compuserve 74017,614

Inquiry 597.

COMMUNICATIONS

MODEM - 2400

INTERNAL 2400 BAUD, HAYES COMPATIBLE
U.S. MADE FOR PC, XT, AT386

\$69 QTY. ONLY

PC VOICE CARD

MESSAGE CENTER, TELEMARKETER

CLEAR VOICE FOR PCXT, AT 386

ITC CORP. 2630 Walnut Ave., Suite E, Tustin CA 92680

(714) 730-1121 FAX: (714) 730-3837

Inquiry 598.

PC-COMM: A SERIAL DATA COMMUNICATIONS ANALYZER

Displays bidirectional RS-232 data traffic. Logs data to disk monitoring at 19.2K baud. Indicates errors and RS-232 control signals. Runs on all IBM PC/AT/PS2 compatibles. Transfers binary files at 19.2K baud.

PC-COMM \$165 Cable option \$65 S/H \$5

Santa Rosa Software

99 Alden Ave., Rohnert Park, CA 94928
707-664-8440

Inquiry 599.

COMPUTER INSURANCE

INSURES YOUR COMPUTER

SAFWARE provides full replacement of hardware, media and purchased software. As little as \$39 a year provides comprehensive coverage. Blanket coverage; no list of equipment needed. One call does it all. Call 8 am-10 pm ET. (Sat. 9 to 5)

TOLL FREE 1-800-848-3469

(Local 614-262-0559)

SAFWARE, The Insurance Agency Inc.

Inquiry 600.

COMPUTER MAINTENANCE

FREE TOOL CATALOG

Jensen's new catalog features hard-to-find tools, test equipment, computer and workstation accessories, tool kits, hundreds of items used for computer service, maintenance, and repair.

For your free catalog, call or write:

JENSEN TOOLS INC.

7815 S. 46th St., Phoenix, AZ 85044
(602) 968-6231

Inquiry 601.

THE BUYER'S MART

CROSS ASSEMBLERS

CROSS ASSEMBLERS

Universal Linker, Librarian
Targets for 36 Microprocessors
Hosts: PC/MS DOS, micro VAX, VAX 8000
Developed and supported at:

ENERTEC, INC.

BOX 1312, Lansdale, PA 19446
Tel: 215-362-0966 Fax: 215-362-2404

Inquiry 602.

DATA CONVERSION

MEDIA CONVERSION/DATA TRANSLATION

More than just a straight dump or ASCII transfer!
Word Processing, DBMS, and Spreadsheet data on Disks or Tapes transferred directly into applications running on Mainframes, Minis, Micros, Dedicated Word Processors, Typesetters, and Electronic Publishing systems.
IBM PS/2 & Macintosh supported
#1 in the translation industry!

CompuData Translators, Inc.

3325 Wilshire Blvd., Suite 1202, Los Angeles, CA 90010
(213) 387-4477 1-800-825-8251

Inquiry 608.

DATA/DISK CONVERSION

DISK & TAPE CONVERSIONS AUTOMATICALLY

SAVE TIME AND MONEY

Over 1000 formats from Mini, Micro Mainframe, Word Processors, & Typesetters.

TAPE Conversions as low as \$23.00 MB
DISK Conversions as low as \$15.00 per Disk
Call or write TODAY for a cost saving quotation.

CREATIVE DATA SERVICES

1210 W. Latimer Ave., Campbell, CA 95008
(408) 866-6080

Inquiry 614.

DATABASE MGMT SYSTEMS

FREE TRIAL dBASE III CLON!!

"1 on 1 is a programmable relational DBMS... The menu mode is a fancier and more complete version of DBases's assistant mode... 1 on 1 = 3! is a great deal for those who would be glad to have a dBASE III PLUS clone!"

** PC MAGAZINE 5/17/88 **

Free 30 day trial full program USA only or Buy now get free upgrade. Money back guarantee \$69 + \$5. S/H chkl/Amex. CAN +\$4. Other +\$10. Call or write:

1 on 1 Computer Solutions

26 Finchwood Dr., Trumbull, CT 06611 203-375-0914
dBASE III is a trademark of Ashton-TATE

Inquiry 609.

Professional Series

PseudoCode releases its PseudoSam professional Series of crossassemblers. Most popular processors. Macros, Conditional Assembly, and Include Files. Virtually unlimited size. For IBM PC's, MS-DOS 2.0 or greater. With manual for \$50.00. (MI res. 4% tax). Simulators and disassemblers also available. Shipping \$5, Canada \$10, Foreign \$15. Visa/MC.

KORE Inc.

6910 Patterson, Caledonia, MI 49316 616-791-9333
30 Day satisfaction guaranteed or purchase price refunded.

Inquiry 603.

FROM MACs TO MAINFRAMES...

Our 12 conversion systems support over 1000 formats

DISK INTERCHANGE SERVICE COMPANY

2 Park Drive • Westford, MA 01886
(508) 692-0050

Inquiry 615.

FANTASTIC SIMULATORS

For the 8048, 8051, 8080, 8085, & Z80 families. Full function simulation including ALL MODES of interrupts. Built-in disassembler. Better than expensive I.C.E.'s.

CROSS ASSEMBLERS

We support the 8048, 8051, 8080/8085, 8096 & Z80 families. Just \$75 each.

Lear Com Company

2440 Kipling St./Ste. 206, Lakewood, CO 80215
303-232-2226

Inquiry 604.

BTRIEVE™ XTRIEVE™ USERS

FRAME™ language creates & accesses BTRIEVE files with 4GL commands. More flexible than a menu system. Has display, comparison, edit, iteration, capture, report capabilities. Quickly write file utilities and prototypes to use once, a few times, or as an application. Effort savings worth introductory offer \$59 + \$3 S/H.
Printed manual (380 pp) and screen tutorial (326 ss).

FRAME SOFTWARE, INC.

90 W. Montgomery St., Suite 163
Rockville, MD 20850
VISA/MC (301) 881-6893

Inquiry 610.

THE #1 CHOICE

In disk & tape conversion

for many leading corporations, government agencies, law firms, and companies in every industry—world-wide.

Free test • Satisfaction guaranteed

Call the helpful conversion experts...

Graphics Unlimited Inc.

3000 Second St. North, Minneapolis, MN 55411
(612) 588-7571

Inquiry 616.

CROSS ASSEMBLERS

Macros, PC Compatible, Relocatable, Conditionals, Fast, Reliable... from \$150
also: Disassemblers

EPROM Programmer Board

MICROCOMPUTER TOOLS CO.

Phone (800) 443-0779

In CA (415) 825-4200

912 Hastings Dr., Concord, CA 94518

Inquiry 605.

query dBASE IV data in OS/2

don't waste time waiting for a huge program to load up
C>SELECT • FROM DATABASE

- SELECT can read dBASE III+ & IV database & index
- DOS & OS/2 protected mode version, multiuser
- set up query by filling table, no programming
- filter, relation, calc field, graph, histogram, report
- DOS \$38 OS/2 \$38 both \$68 + \$3 S/H check/visa/MC

YSC Tech (416) 733-0228

47 Prolea Gardens, Willowdale, ON M2K2W5, CANADA
dBASE IV is trademark of Ashton-Tate

Inquiry 611.

DATA/DISK CONVERSION

Get the Expertise You Need! Disk/Disk • Tape/Disk • OCR

Over 1,000 formats! 3 1/2, 5 1/4, or 8 inch disks; 9 track mag tape; 10 MB Bernoulli cartridge. Data base and word processor translation. Specialists in Government Security Data. Call for free consultation.

Computer Conversions, Inc.

9580 Black Mtn. Rd., Ste J, San Diego, CA 92126
(619) 693-1697

Inquiry 612.

CONVERSION SERVICES

Convert any 9 track magnetic tape to or from over 1000 formats including 3 1/2", 5 1/4", 8" disk formats & word processors. Disk to disk conversions also available. Call for more info. Introducing OCR Scanning Services.

Pivar Computing Services, Inc.

165 Arlington Hgts. Rd., Dept. #B
Buffalo Grove, IL 60089 (312) 459-6010

Inquiry 618.

680X0 Cross Assemblers

Now, inexpensive quality 680X0 Cross-Assemblers that use your IBM PC or compatible. All versions support up to 32 char labels, INCLUDE files, PATH names, extensive list output, sorted symbol tables, many common directives, printed manuals. Basic versions create S-records. Linking versions include a librarian & linker, create either S-record or relocatable modules. In led to create S-records or binary files. Minimum requirements are 320K, DOS 2.XX, & 1.5 1/4" DSDD.

Basic 68000/68010—\$49.95 Basic 68020—\$69.95
Linking 68000/68010—\$89.95 Linking 68020/68881—\$129.95

Linking 68030/68881—\$149.95
Checks, VISA, MC accepted. MN residents +6% sales tax.
No PC's or COD's please.

RAVEN Computer Systems

Box 12116, St. Paul, MN 55112 (612) 636-0365

Inquiry 606.

6800-Family Development Software

Our C Compilers for the 6800, 6801, 6809, & 68HC11 feature a complete implementation (excluding bit fields) of C as described by K&R and yield 30-70% less code than other compilers. Our Assemblers feature macros and conditional assembly. Linker & Terminal Emulator included.

Wintek Corporation

1801 South St., Lafayette, IN 47904
(800) 742-6809 or (317) 742-8428

Inquiry 607.

DISK CONVERSIONS

Media transfer to or from: IBM, Xerox, DEC, Wang, Lanier, CPT, Microm, NBI, CT, also WP, WS, MS/WORD, DW4, MM, Samna, DEC DX, MAS 11, Xerox-Writer, ASCII.

FREE TEST CONVERSION CONVERSION SPECIALISTS

531 Main St., Ste. 835, El Segundo, CA 90245
(213) 545-6551 (213) 322-6319

Inquiry 613.

DEMOS/TUTORIALS

LEARN THE ABC'S OF 1-2-3

LEADING EDGE'S New Softvision VCR Training ACCELERATES learning LOTUS 1-2-3. You get: 84-min videotape, workbook and practice disk. Now you're up-to-speed on Lotus 1-2-3. Just \$29.95 + 2.50 P&H. ORDER NOW. Money back if not delighted. All major credit cards. CALL NOW.

LIFE DYNAMICS

6050 Peachtree Pkwy., #240-226, Norcross, GA 30091
(800) 548-9608 M-F 10-6
(800) 548-5782 Ext. 12 ANYTIME

Inquiry 619.

THE BUYER'S MART

DEMOS/TUTORIALS

INSTANT REPLAY III

Build Demos, Tutorials, Prototypes, Presentations, Music, Timed Keyboard Macros, and Menu Systems. Includes Screen Maker, Keystroke/Time Editor, Program Memorizer, and Animator. Rec'd *Great Reviews!* Simply the BEST. Not copy protected. No royalties. 60 day satisfaction money back guar. IBM and Compat. \$149.95 U.S.Chk/Cr. Crd. Demo Diskette \$5.00

NOSTRADAMUS, INC.

P.O. Box 9252
Salt Lake City, Utah 84109 (801) 487-9662

Inquiry 620.

DISASSEMBLERS

SOFT-X-PLORE

See "BYTE's May '88 issue pg. 78". Disassemble 500 kb (*) program at 10,000/min. (*) in any file, ROM/RAM memory up to 80386 instruction set(*). SOFT-X-plore:
* is for MS/DOS 2.0+ systems
* uses 20 algorithms and seven passes (*)
* only \$99.95 plus S&H w/30 day guarantee
To order call (800) 446-4656 or info (203) 560-0236

Or write: **RJSWANTEK, INC.**

178 Brookside Rd., Newington Ct 06111
* best on the market MC/VISA accepted

Inquiry 621.

DISK COMPATIBILITY

IBM PC's USE Mac DISKS

MatchMaker lets you plug any Macintosh external floppy drive into an IBM PC. Half size card and software lets you copy to/from, view directory, initialize, or delete files on the Mac diskette. Works with PCs, XT's, AT's, and compatibles. *The easy way to move information!*

\$149.00 Visa/MC/COD/Chk.

Micro Solutions Computer Products
132 W. Lincoln Hwy., DeKalb, IL 60115 815/756-3411

Inquiry 622.

DISK DRIVES

PS/2 DRIVES FOR PC's AT's

CompatiKit/PC \$279
CompatiKit/AT \$219

Built-in floppy controllers—no problem. Supports multiple drives and formats. Lets your computer use IBM PS/2 1.4M diskettes *plus more!* Call for further information or to place an order.
VISA/MC/COD/CHECK.

Micro Solutions Computer Products
132 W. Lincoln Hwy., DeKalb, IL 60115 815/756-3411

Inquiry 623.

DISK DUPLICATION

SOFTWARE PRODUCTION

- Disk duplication
- All formats
- EVERLOCK copy protection
- Label/sleeve printing
- Full packaging services
- Warehousing
- Drop shipping
- Fulfillment
- 48-hour delivery
- Consultation & guidance

Star-Byte, Inc.

2880 Bergey Rd., Hatfield, PA 19440
215-997-2470 800-243-1515

Inquiry 624.

DUPLICATION SERVICES

SOFTWARE DUPLICATION

- One Stop Shopping
- Custom Packaging
- Copy Protection
- Technical Support
- Drop Shipping
- Fast Turnaround
- Competitive Pricing

SATISFACTION GUARANTEED
800-222-0490 NJ 201-462-7628

MEGASoft

P.O. Box 710, Freehold, NJ 07728 See our ads on page 322.

Inquiry 625.

EDUCATIONAL VIDEOS

EZ-PC : MS-DOS VIDEO

COMPUTER TRAINING MADE SIMPLE
• Learn MS-DOS Quick & Easy
• No computer jargon—All terms explained
• No prerequisites—Anyone can learn
• Affordable training in your home

ORDER NOW - \$24.95

Add \$2.00 Shipping VISA/MC/AMEX-Check
VIDEOMATION PRODUCTIONS, INC.
8323 Burwood Park Dr., Spring, Texas 77379
713-251-4224

Inquiry 626.

ENTERTAINMENT

NEMESIS™ Go Master®

Go, a game of strategic elegance, has been a way of life in the Orient for over four thousand years. Many consider Go to be the secret of the Japanese businessman's success. *"While chess is a game of war, Go is a game of market share"* [President of Nikko Hotels].

"If you are interested in Go, buy this program."

Game of the Month J. Pournelle BYTE 7/87

Toyogo, Inc. The Leader in Computer Go.
76 Bedford St. #34-Y, Lexington, MA 02173, (617) 861-0488

Inquiry 627.

FAX COMMUNICATIONS

COMPLETE FAX \$295

Grp. III FAX capability for your PC. Bkgrd. operation, w/pop-up "hot key" for direct faxing from most applications. Scheduled/broadcast transmission, auto redial. Optional 9600 bps, voice mail, more! 2 yr. warranty from The Complete PC. Free 2nd day air shipping.

R. Gile Electronics

358 So. Main St., Ste. #36
Orange, CA 92668

To order, call (800) 527-4453 or (714) 634-3353 24 hr.
For info, poll FAX (714) 634-1644

Inquiry 628.

FLOW CHARTS

Flowchart/State Diagram for Engineers

Draw flowcharts or state diagrams with this MacDraw like program on your IBM PC/AT/PS2 or compatible. All flowchart symbols are prebuilt and can be stretched to any size. Add your own symbols to the symbol library. Ellipses, curves with ending arrowheads, cut/paste, enlarge/reduce, drag, zoom out, undo, etc. Output to most printers, plotters, and desktop publishing software. Complete with Logitech Mouse for \$89. See our larger ad every other month.

Daytron Electronics Inc.

610 S. Sherman #104, Richardson, TX 75081 214-669-2137

Inquiry 629.

FLOW CHARTING II+ HELPS YOU!

Precise flowcharting is fast and simple with Flow Charting II+. Draw, edit and print perfect charts: bold and normal fonts, 26 shapes — 95 sizes; fast entry of arrows, bypasses & connectors; Fast Insert Line; shrink screen displays 200-column chart; 40 column edit screen for detail work, much more!

PATTON & PATTON

81 Great Oaks Blvd., San Jose, CA 95119
1-800-525-0082 Ext. 42 (Outside CA)
408-629-5376 Ext. 42 (CA/Int'l)

Inquiry 629.

WINDOWS FLOWCHARTER \$79

RFFlow is a drawing tool designed specifically for flowcharts. Easy to learn, easy to use. 75 shapes automatically adjust in size. Move, copy, or delete groups of objects. 7 levels of zoom. Use mouse or keyboard. On-line user's manual. Supports Windows printers, plotters, and fonts. \$5 trial disc. RFFlow requires Microsoft® Windows.

RFF ELECTRONICS

1053 Banyan Court, Loveland, CO 80538
(303) 663-5767

Inquiry 630.

FLOW CHARTS

STRUCTURED FLOW CHART

NSChart creates Nassi-Shneiderman (structured) flowcharts from a simple PDL. Keywords define structures & text strings appear in the chart. Easy to create, even easier to revise! Automatic chart sizing, text centering. Translators from many languages available. For Mac and IBM PC.

SILTRONIX, INC.

P.O. Box 82544, San Diego, CA 92138
1-800-637-4888

Inquiry 631.

FORTRAN TOOLS

Tame Your Fortran Code!

Make your Fortran source more readable, portable, and maintainable.

PRETTY cleans up code: indents, relabels, changes GOTOs to IF-THEN-ELSEs, etc.

OUTLINE graphically highlights IF and DO nesting.

PREP supports conditional compilation, include files.

Plus four more. MS-DOS. All for \$29.

Qulbus Enterprises, Inc.

106 N. Draper Ave., Champaign, IL 61821
(217) 356-8876

Inquiry 632.

GRAPHICS

35mm SLIDES—In 24 Hours

We transform your PC-Graphics files into full-color high-resolution, 35mm slides and ship within 24 hours. Harvard, Pixie, Lotus, Freelance, and others supported. Files accepted by modem. Free Federal Express on all orders of 20+ slides. Only \$8 per slide. Call for literature or circle reader service number shown below.

Accent Presentations, Inc.

990 Highland Drive, Ste. 202, P.O. Box 1303, Solana Beach, CA 92075
1-800-222-2592

Inquiry 633.

RAINDROP™

FAST, compact PrtScrN Utility for end users AND developers. Hardcopy as fast as 10 secs. Average binary size - 6 kbyte. 12 video graphic standards. Scale, rotate, colorize and more. 'CALL' from user written programs. Complete 9 & 24 pin dot matrix, inkjet, and laserjet library \$39.95+\$3 s/h.

RAINBOW TECHNOLOGIES

8106 St. David Ct., Springfield, VA 22153
(703) 440-0064

Inquiry 634.

HARD DRIVE REPAIR

HARD DRIVE REPAIR

WE WILL REPAIR YOUR HARD DRIVE AT A FRACTION OF THE COST OF REPLACING IT. FAST TURNAROUND!!! CALL FOR DETAILS

H & W micro, inc.

528-C FOREST PARKWAY
FOREST PARK, GA 30055
(404) 366-1600

Inquiry 635.

HARDWARE

CHIP CHECKER

- 74/54 TTL + CMOS
- 14/4000 CMOS
- 14-24 Pin Chips
- 8000 Nat. + Signetics
- 9000 TTL
- .3" + .6" IC widths

Tests/Identifies over 650 digital chips with ANY type of output in seconds. Also tests popular RAM chips. IBM compatible version \$259. C128 + C64 version \$159.

DUNE SYSTEMS

2603 Willa Dr., St. Joseph, MI 49085
(616) 983-2352

Inquiry 636.

THE BUYER'S MART

HARDWARE

Equipment Monitor And Control

Ideal cost effective computer can be used to perform data acquisition and control using a dumb terminal or create data files on a PC. Features 16 chan. A/D, 64 digital I/O lines, 4 timer/counters and 4 serial ports. Options 4 chan. D/A, clock, GMS, Forth OS, and networking.

E-PAC 1000 + \$249.00 E-PAC 2000 + \$449.00

EMAC INC.

P.O. Box 2042, Carbondale IL 62901

Phone: 618-529-4525 Fax: 618-457-0110

Inquiry 637.

FREE CATALOG

Protect your computer power from black-outs, brown-outs, audio/video hash and surges! Complete line of low cost *Emergency Power Supply units, Line Conditioners and Surge Suppressors* prevent damage and loss of valuable data. Prevent errors, malfunctions and false printouts! Send for money saving catalog today.

INDUS-TOOL

730 W. Lake St., Chicago, IL 60606

Phone 312-648-2191

Inquiry 638.

PC CARDS/BREADBOARDS

- AD8-1, 8 bit A/D, digital osc. software . . . \$99
- 8 bit fast A/D, 8CH, GAIN 1,10,100 . . . \$199
- 12 bit A/D, 8CH, S/H, GAIN 1,10,100 . . . \$279
- DIQ24, 24 TTL I/O, 8255 PPI . . . \$89
- Driver, 21-50V, 300mA) OC outputs . . . \$99
- Printer Port or RS232 Breadboard . . . \$129

JB COMPU-TRONIX

P.O. Box 27717, Lakewood, CO 80227

(303) 987-3239

Inquiry 639.

AWARD BIOS UPDATE!

PC/XT Version 3.1

Now Support s 144 Mb 3.5" Floppies

286/386 Version 3.04

Revised Drive Tables, EGA & VGA Support

Authorized AWARD Distributor

1-800-423-3400 or (412) 782-0384

KOMPUTERWERK, INC.

851 Parkview Blvd., Pittsburgh, PA 15215

Inquiry 640.

Wholesale PC Parts

- 286 6/12mhz AT Baby Motherboard . . . \$199
- 1.2 High Density Floppy . . . \$71
- 1200b Modem, Internal . . . \$49
- IBM Compatible Mouse, Serial . . . \$34

Authorized Mark V distributor of IBM Compatibles
Prices starting at \$299

Micro N.W. Distributors

22043 68th Ave. South, Kent, WA 98032

Call: 206-859-9210

Inquiry 641.

Apple • Service Parts

- Accessories • Systems •
- BUY ★ SELL ★ TRADE

PRE-OWNED Electronics, Inc.

30 Clematis Avenue, Waltham, MA 02154

800-274-5343 FAX 617-891-3556

Service Centers and Dealers welcome

Inquiry 642.

304 B Y T E • MAY 1989

HARDWARE/ADD-ONS

The World's First Highest Density Module!

- 18 Meg on the smallest surface
- Organization: 2x1024Kx9 bit
- Package: DIL 64 pin Jaded-Standard
- Technology: CMOS, hybrid, 18xHMS1100JP-10
- Compatibility: With two Hitachi HB56A 19-10
- Suitable for extension of basic memory

For more information please write or call:

TermoTrol Corp.

1888 Century Park East, Suite 1900, L.A. CA 90067

Tel: 213 284-3242

Inquiry 643.

HARDWARE/COPROCESSOR

DIGITAL SIGNAL PROCESSOR

DSP products for the IBM PC/XT/AT based on the T1 TMS32010 and TMS320C25. Designed for applications in communications, instrumentation, speech, and numeric processing. Offered with 12 bit 110 KHz A/D and D/A and continuous to disk data acquisition & playback option. \$650 and up.

DALANCO SPRY

89 Westland Ave., Rochester, NY 14618

(716) 473-3610

Inquiry 644.

SC/FOX™ PARALLEL COPROCESSOR

PC/XT/AT/386 plug-in board with Forth software. 10 MIPS operation, up to 50 MIPS burst. 64K to 1M byte memory. Uses Harris RTX 2000™ RISC real-time CPU with 1-cycle multiply, 1-cycle 14-priority interrupts, two 256-word stacks, three 16-bit timer/counters, 16-bit i/o bus. Ideal for real-time control, signal and image processing, and multiple board operation. From \$2,295. Optional SC/FOX Single Board Computer version for stand-alone operation. Eurocard size with software, starting at \$1,495.

SILICON COMPOSERS, INC. (415) 322-9763

210 California Ave., Suite K, Palo Alto, CA 94306

Inquiry 645.

IBM SOFTWARE

IBM* SOFTWARE NEW VERSION

SAVE UP TO 65%, Quantity Limited

First come, First served, VISA/MC/check

COBOL V2.0 \$295 Prof. FORTRAN V1.3 . \$250

C compiler \$195 Macro assembler V2.0 . \$75

BASIC Compiler V2.0 . \$95 BASIC Ref. V3.2 \$25

LAN Program V1.2 \$75 Plotting System \$150

The Computer Place, Inc.

301-330-6016 Fax 301-926-3415

*IBM is trademark of International Business Machine.

Inquiry 646.

INVENTORY MANAGEMENT

STOCK-MASTER 4.0

Commercial grade inventory management software at micro prices.

- Supports all 12 transaction types
- Trend Analysis
- Quality Control
- Multiple Locations
- Purchase Order Tracking
- Open Order Reporting
- Serial/Lot # Tracking
- Stock Status Reporting
- Activity History Analysis
- Bill of Materials
- Purchase Order Writing
- Order Entry
- Material Requirements
- On Line Inquiry

Applied Micro Business Systems, Inc.

177-F Riverside Ave., Newport Beach, CA 92663 714-759-0582

Inquiry 647.

dFELLER Inventory

Business inventory programs written in modifiable dBASE source code.

dFELLER Inventory \$150.00

Requires dBASE II or III, PC-DOS/CPM

dFELLER Plus \$200.00

with History and Purchase Orders

Requires dBASE III or dBASE III Plus (For Stockrooms)

Feller Associates

550 CR PPA, Route 3, Ishpeming, MI 49849

(906) 486-6024

Inquiry 648.

LAPTOP COMPUTERS

LAPTOP SPECIALS

TOSHIBA • Zenith • NEC • SHARP LAPTOPS
• Hard drives for Tandy 1400 LT & Toshiba J100+
• AFFORDABLE 5 1/4" or 3 1/2" DRIVE UNITS for LAPTOPS & DESKTOPS • DICONIX PRINTERS • 768 card for T1000 • 2400 BAUD MODEMS for Laptops • Fast reliable and friendly service. For Low Pricing call World wide sales

COMPUTER OPTIONS UNLIMITED
201-469-7678 (7 Days, 9 am-10 pm Eastern time)

Inquiry 649.

Laptop Connection

2PC — THE File Transfer Utility

- * Lap to Lap, Lap to Desk
- * Super Easy to Use
- * Desk to Desk, PC to PC
- * No Installation Required
- * Breaks the "Bridge-Link" Price Barrier * 115 K Baud

\$55 w/universal cable, \$45 w/o cable

See Jan. 89 Issue—"What's New!" Column—p.94

PLUS . . . Quality Cables at FAIR Prices:

* Null Modem (6') . . . \$12

* Kbd Ext (6') . . . \$12

* Par Print (6') . . . \$10

* Centronics (6') . . . \$12

* Mon Ext (6') . . . \$12

* Serial (6') . . . \$10

MANY MORE CABLES AVAILABLE. Mac & PC (VISA MC)

Thompson Computing—587 F.N. Ventu Park Rd, Ste. 306

Newbury Park, CA 91320, (805) 498-7653 FAX (805) 499-8104

Inquiry 650.

LAPTOP PERIPHERALS

LAPTOP BACKLIGHTS

Factory Installed • 90 Day Warranty

Toshiba, Amstrad, Sanyo, DG,

Kaypro, IBM, HP, etc. \$295

The Portable Peripherals People

Axonix Corporation

(801) 466-9797

Inquiry 651.

MAILING LIST PROGRAMS

YOURS FREE!

"How to Manage Your Mailing List" ArcList® & AccuMail® are two powerful programs for your IBM or compatible PC.

- Duplicate Recognition
- Postal Discount Presorts
- Label Design & Printing
- Carrier Route and Zip+4 Insertion
- Address Correction
- dBase® Compatible

Call 800-368-5806 for a FREE GUIDE

Group 1 Software, Inc.

6404 Ivy Lane, Dept. BIT-5, Greenbelt, MD 20770-1400

Inquiry 652.

MEDICAL

XLI Practice Management System

- Insurance claims—paper & electronic
- Patient data & recall information
- Super bills & statements
- Full financial reporting
- Multiple physicians & work station support
- Customer support lines
- 90 Day trial period

Total Package Only \$1995.00

Practice Management Systems, Inc.

P.O. Box 23723, Columbia, SC 29224

1-800-521-7217

Inquiry 653.

MEMORY CHIPS

MEMORY CHIPS

41256-15-12-10 Call 51000 (1 Meg) Call
4164-15 Call 51258 for Compaq 386. Call
4164-12 Call 8087-3-2 Call
41128 Piggy Back for AT Call 80287-6-9-10 Call
41464-12 (64Kx4) Call 80387 Call
414256 (256Kx4) Call NECV-20-8 Call
2764,27128,27256,27512 Call Mouse Call
Prices subject to change

ESSKAY 718-353-3353

Inquiry 654.

THE BUYER'S MART

MEMORY CHIPS

D-RAMS

NEW AND PULLS AT LOW COST
WE ALSO SELL SIPPS, ZIPS,
SIMS AND OTHER MODULES.
SPECIAL 256-15P \$7.95

ITC CORP. 2630 Walnut Ave., Suite E, Tustin CA 92680
(714) 730-1121 FAX: (714) 730-3837

Inquiry 655.

MIDI

LAPTOP PS/2 PC/XT/AT

MIDIATOR®, Music interface with Serial I/O, MIDI In, MIDI Out, & RealTime clock. Connects any PC compatible RS-232 Port without ext. power, card slot, system mode. Software: KEENote-16 multi-track record/play, edit, save/load, more. MonKEE manages MIDI data. Separately \$219.85. Introductory Special—ALL for \$129.95 + 5.00 S&H USA. MC, VISA, COD, Check (10 days), TX res. add 7.5% tax.

KEE • Key Electronic Enterprises • KEE
9112 Hwy. 80 W., Suite 221-B, Fort Worth, TX 76116
Order 1-800-KEE-MIDI Tech (817) 560-1912

Inquiry 656.

OBJECT ORIENTED TOOLS

OBJECT ORIENTED TOOLKIT

TRIPLE your productivity with Complete C™
The only C object oriented development utility with precompiler, foundation classes (source code included), make, integrated debugger, documentation generator, profiler, streamliner, and full technical support.

Introductory Price: \$269

Complete Computer Corporation
111 West 57th St., NY, NY 10019
212-582-2635

Inquiry 657.

PROGRAMMERS TOOLS

Menu Creator™ \$99.95

A program generator for menu-driven user interface. Edit menu windows interactively using WYSIWYG screen editor—Menu Creator™ generates a linkable menu object file. Excellent for complex menu systems. Capable of handling command trees with hundreds of menu items. Mouse support and context-sensitive help. FORTRAN, PASCAL, C, BASIC supported.

Call your dealer

For free utility software contact: **Avanpro Corp.**
P.O. Box 969, Pacific Palisades, CA 90272
(213) 454-3866

Inquiry 658.

TLIB™ 4.2 Version Control

"TLIB™ is a great system" — *PC Tech Journal 3/88*. Full-featured configuration mgmt for software professionals. All versions of your code instantly available. Very compact, only changes are stored. Check-in/out/locks, revision merge, branching, more. Mainframe deltas for Pansophic, ADR, IBM, Unisys. Only \$99.95 + S&H, or 5-station LAN \$299.95 + S&H. VISA/MC

BURTON SYSTEMS SOFTWARE
P.O. Box 4156, Cary, NC 27519 (919) 856-0475

Inquiry 659.

Have Same 'C' Source for UNIX and DOS
D-ISAM—Unix standard indexed file management library for UNIX DOS and NETWORKS. Manages all locking. UNIX/DOS source \$595 (for both), DOS libs \$145.

W—Character windowing with COLORS, Line Graphics, Bellands more. You need not modify DOS code to work WELL on any UNIX terminal. UNIX/DOS source \$295 (for both), DOS libs \$95.

BYTE DESIGNS

P.O. Box F195-76, Blaine, WA 98230
1-800-663-8547 or (604) 278-5200
*DOS libs available for Microsoft or Borland C compilers

Inquiry 660.

PROGRAMMERS TOOLS

Async Executive™ & Tutorial

Interrupt driven transmit & receive. Supports up to eight ports. Buffered I/O to 64K 50 to 19200BPS. XON/XOFF. DTE/DCE. Modem controls. Transfer characters or blocks. Millisecond timing. Universal language interface. BIOS/DOS extension capabilities. XMODEM w/CRC. 200+ page comprehensive manual. Sample programs include a spooler written in C. For IBM PC/XT/AT & all compatibles. Software Developer's Kit: \$595.

Shipping \$5, Canada \$10, Foreign \$15
CA residents add 6% tax. Checks/MO only.

CIRRUS SOFTWARE, INC.
P.O. Box 51924, Dept. B, Palo Alto, CA 94303
(415) 949-1470

Inquiry 661.

'C' WINDOWING \$49.95

MS-DOS virtual screen library. Unlimited text windows. 100+ functions/macros. Move, resize, hide, pop-up, edit, etc. Attributes, tabs, scroll/alignment bars. K&R print, raw/processed I/O, cursor mgmt. Easy to use. Excellent doc. NJ add 6%. \$3.00 S&H. 15 day \$ back. Check or money order. Specify compiler (Microsoft, Lattice, Turbo). Allow 2-4 wks. Write:

Commonwealth Data Systems, Inc.
P.O. Box 568, Lincroft, NJ 07738

Inquiry 662.

DEVELOPMENT TOOLS

Professional Programmers Extender: Standard Mac interface, lists, printing, graphics, tiling. Extender GraphPac: Quality color graphs. Line, bar, semi-log, customizable symbols.

INVENTION Software
(313) 996-8108

Inquiry 663.

CREATIVE INTERFACE TOOLS for Borland Language Users

Create graphic mouse cursors, symbols, bit-mapped character sets, and dynamic, self-calculating menus in text or graphics. Control program flow with keyboard or mouse. Supports Turbo C, Turbo Pascal, Turbo Prolog and Turbo Basic. Three features, one price.

\$69.95

1-800-622-8366

Maxx Data Systems, Inc.
1126 S. Cedar Ridge, Suite 115, Duncanville, TX 75137

Inquiry 664.

TURBO PLUS \$149.95

Programming tools for Turbo Pascal 5.0 Screen Painter, Code Generator, I/O Fields, Dynamic Menus, Programming Unit Libraries, Sample Programs, 280 Page Illustrated Manual. 60 Day Satisfaction Guarantee! Brochures & Demo Diskettes avail. Highly Favorable Reviews! IBM & Compatibles.

Nostradamus Inc.

P.O. Box 9252, Salt Lake City, UT 84109
(801) 487-9662

Inquiry 665.

Get INSIDE!

The best PC software performance tool is now better than ever with source line timing, caller timing and arbitrary event timing—all with microsecond accuracy and without source modification. The expanded DOS analysis mode identifies I/O bottlenecks. \$125

Call today for a free brochure and the latest list of supported compilers. 30-day guarantee. VISA/MC/COD

Paradigm Systems

P.O. Box 152, Milford, MA 01757
(800) 537-5043 In MA: (508) 478-0499

PROGRAMMERS TOOLS

FREE BUYER'S GUIDE

Programmer's Connection is an independent dealer representing more than 300 manufacturers with over 600 software products for IBM personal computers and compatibles. We have serviced the professional programmer since 1984 by offering sound advice and low prices. Call or write today to receive your FREE comprehensive Buyer's Guide.

Programmer's Connection US 800-336-1166
7249 Whipple Ave. NW Canada 800-225-1166
North Canton, OH 44720 International 216-494-3781

Inquiry 667.

'C' DOCUMENTATION TOOLS

- C-CALL \$59 Creates graphic-tree of caller/called structures, and files-vs-procedure table-of-contents
- C-HDR \$59 Creates/inserts/updates headers for each procedure showing caller/called and identifiers
- C-LIST \$39 List, action-diagram, reformat programs
- C-REF \$49 Local/global/parameter cross reference
- SPECIAL \$149 All 4 plus integrated C-DOC version

SOFTWARE BLACKSMITHS INC.
6064 St. Ives Way, Mississauga, ONT Canada L5N-4M1
(416) 858-4466

Inquiry 668.

PUBLIC DOMAIN

\$3.00 SOFTWARE FOR IBM PC

Hundreds to choose from, wordprocessors, databases, spreadsheets, games, lotto, communications, business, music, bible, art, education, language and useful utilities for making your computer easier to learn. Most programs have documentation on the disk.

Free 125 page catalog.

BEST BITS & BYTES

P.O. Box 8245, Dept-B, Van Nuys, CA 91409
In CA: (818) 764-9503 800-245-BYTE

Inquiry 669.

\$1 per DISK SALE

20 TOP IBM PC PD/SW DISKS
(360K) ONLY \$20 + \$3 S&H

QubeCalc, EDRAW, AutoMenu, Math Tutor, PC-DOS Help, Baker's Dozen, Languages, EZ-Form, PC-Style, PackDisk, PC-Stock, KidGames, Best Games, Home Inventory, PC-Outline, Form Letters, ImagePrint, SideWriter, PC-Prompt, Best Utilities.

BRIGHT FUTURES INCORPORATED

P.O. Box 1030, East Windsor, CT 06088
FREE CATALOG (\$1.25 per disk)

Inquiry 670.

FREE SOFTWARE BEST OF PUBLIC DOMAIN & SHAREWARE.

Carefully selected and edited programs for I.B.M.
Send S.A.S.E. for free catalog.

C.C.S., Inc. Dept. B1
P.O. Box 312, Lafayette Hill, PA 19444

Inquiry 671.

FREE CATALOG PUBLIC DOMAIN/SHAREWARE

- 400 IBM PC & compatibles disks •
- 200 Amiga disks • 125 Atari ST disks

PC disks as low as \$1.25 each, Amiga & ST as low as \$1.60 each! Rent or buy. Free shipping! Call toll free, write or circle reader service for FREE BIG CATALOG with full descriptions. Please specify computer—48 hr. turnaround!

Computer Solutions

P.O. Box 354—Dept. B, Mason, Michigan 48854
1-800-874-9375 (M-F 10-8 EST) 1-517-628-2943

Inquiry 672.

THE BUYER'S MART

PUBLIC DOMAIN

- CLIP ART
- GRAPHICS
- LASER FONTS
- CAD
- ELECTRONICS
- GAMES
- TRAVEL
- AUDIO/VIDEO
- SECURITY
- EDUCATION

For **FREE CATALOG** write to:
CWI Information Services

P.O. BOX 4851, Anaheim, CA 92803

Or telephone (714) 879-7917 24 HOURS!

Inquiry 673.

RENT SOFTWARE \$1/DISK

Rent Public Domain and User Supported Software for \$1 per diskfull or we'll copy. IBM (3 1/2" also), Apple, C-64, Sanyo 550 and Mac. Sampler \$3. VISA/MC. 24 hr. info/order line. (619) 941-3244 or send #10 SASE (specify computer) Money Back Guarantee!

FutureSystems

Box 3040 (T), Vista, CA 92083

office: 10-6 PST Mon-Sat. (619) 941-9761

Inquiry 674.

PUBLIC DOMAIN SHAREWARE

1000's Highest
OF SELECTIONS Quality

PD SOFTWAREHOUSE

CALL FOR A
FREE CATALOG
1-800-548-7360

Inquiry 675.

World's Largest Software Library

Thousands of powerful programs for IBM/PC, XT, AT (3.5 format available) and Apple IIe, GS. Items including Business, CAD, Education, Games, and Religion. Free catalog sent to you by Airmail, specify your computer type, write:

RELIANT

dept-byte, P.O. Box 33610, Sheungwan, Hong Kong

Inquiry 676.

FREE IBM SOFTWARE

FREE CATALOG also contains SHAREWARE. 5 1/4 and 3 1/2-inch. All categories. ENGINEERING, CAD, DESKTOP PUBLISHING, LANGUAGES, UTILITIES, BUSINESS, GRAPHICS, SPREADSHEETS, WORD PROCESSORS, CHURCH, MEDICAL, HEALTH, EDUCATION, HOME.

SECTOR SYSTEMS COMPANY, INC.

Dept. B-5, 416 Ocean Avenue, Marblehead, MA 01945

(617) 639-2625

Inquiry 677.

FREE CATALOG

\$1 IBM SOFTWARE

For your free 32 page Master Edition catalog featuring the best of IBM Shareware from just \$1 each, call or write today!

1-800-338-2118

SOFSOURCE

Box 828, East Lansing, MI 48826

Inquiry 678.

306 B Y T E • MAY 1989

PUBLIC DOMAIN

FREE SOFTWARE CATALOG

Low as \$1.20/disk
Over 1000 quality IBM software
On 5.25" and 3.5" format
From outside U.S.A., except Canada,
please send US \$2.00 refundable with order.
For fast service, write to

SOFTSHOPPE

P.O. BOX 709, Ann Arbor, MI 48105

(313) 763-8721

Inquiry 679.

FREE SOFTWARE

We send you 15-20 new IBM programs a month on 5 disks—FREE! You pay only \$5. shipping/handling. Annual membership reg. \$29.95. Join today for only \$9.95 and we'll send you over 30 programs on 10 disks as a bonus—FREE! No gimmicks—no catches!

toll free 800 669-2669 ext 348

SOFTWARE of the MONTH CLUB
we take visa/mastercard/amex

Inquiry 680.

16 and 32 BIT MICROS

EDUCATIONAL TRAINING SYSTEMS in a notebook with power supply — for the Motorola 68000/68020/68881, TMS32010 DSP, Intel 8086/8087, A/D-D/A Converters, cross assemblers, serial interfaces with software, complete systems, documentation, schematic, operating system, cables, Starting Prices — \$230.00

Phone URDA, Inc.

1-800-338-0517

Inquiry 681.

SECURITY

EVERLOCK COPY PROTECTION

- * Thwarts ALL Bit-copy Software
- * Protect any COM/EXE w/o Source changes
- * Shut down Debug Tracing & Disassemblers
- * Install to Floppy, Hard Disk, or LAN
- * Remotely reset Program Install-Count, Expire-Date or #Executes
- * No damaged media or I/O plugs

For IBM and clones. \$195 & up. Free Info.

Az-Tech Software, Inc.

305 East Franklin, Richmond, MO 64085

(800) 227-0644

(816) 776-2700

FAX: (816) 776-8398

Inquiry 682.

THE ULTIMATE COPY PROTECTION

- Completely Menu Driven
- Defeats all Hardware/Software Copiers
- No Source Code Changes
- Multiple Layering
- No Damaged Media
- Full Hard Disk Support
- Unlimited Metering
- FREE Demo Disk

Quite
Simply
The Best
Way To
Protect
Your Valuable
Software Investment

STOPCOPY* \$325** STOPCOPY PLUS* \$450**

BBI COMPUTER SYSTEMS® (301) 871-1094

14105 Heritage La., Silver Spring, MD 20906 FAX: (301) 460-7545

Inquiry 683.

BIT-LOCK® SECURITY

Piracy SURVIVAL 5 YEARS proves effectiveness of powerful multilayered security. Rapid decryption algorithms. Reliable/small port transparent security device. PARALLEL or SERIAL port. Complemented by economical KEY-LOCK™ and multifeatured COMPU-LOCK™ including countdown, timeout, data encryption, and multiproduct protection.

MICROCOMPUTER APPLICATIONS

3167 E. Otero Circle, Littleton, CO 80122

(303) 922-6410/770-1863

Inquiry 684.

SECURITY

COPY PROTECTION

The world's leading software manufacturers depend on Softguard copy protection systems. Your FREE DISKETTE introduces you to SuperLock™—invisible copy protection for IBM-PC (and compatibles) and Macintosh.

- Hard disk support
- Customized versions
- No source code changes
- LAN support
- New upgrades available

(408) 773-9680

SOFTGUARD SYSTEMS, INC.

710 Lakeway, Suite 200, Sunnyvale, CA 94086

FAX (408) 773-1405

Inquiry 685.

SOFTWARE/ACCOUNTING

PC TIME CLOCK

AutoTime is an Employee Management System that allows you to turn any PC into an Electronic Time Clock. AutoTime provides Time & Attendance, Job Costing, Payroll Interface, and Labor Distribution reporting. Network compatible. Prices start at \$495. Other Business Products: Network FAX, Absence Call-In, db-EDI.

Chase Technologies

1617 Kingman Ave., San Jose, CA 95128

(408) 998-2917

Inquiry 686.

dBASE BUSINESS TOOLS

- GENERAL LEDGER
- ORDER ENTRY
- JOB COSTING
- BILL OF MATLS
- PAYROLL
- PURCH ORD/INVTNRY
- ACCOUNTS RECEVABLE
- JOB ESTIMATING
- SALES ANALYSIS
- ACCOUNTS PAYABLE

\$99 ea. + S&H

dATAMAR SYSTEMS Cred. Card-Check-COD

4876-B Santa Monica Ave.

San Diego, CA 92107

(619) 223-3344

Inquiry 687.

SOFTWARE/BASIC

Save time, money, & brain cells!

QuickWindows Advanced user-interface library supports windows, menus, dialog boxes, help, mouse, and more. For text and graphics modes thru VGA. Fast and intuitive! QuickComm communications library supports up to 16 comm ports, Hayes modems, xmodem and ymodem file transfer, and more. All interrupt driven. Easy to use!

Each library written in assembly and comes with complete manual, \$139 each. For Microsoft QuickBasic or BASCOM.

Software Interphase, Inc.

5 Bradley Street, Suite 106, Providence, RI 02908

(401) 274-5465 Call now for FREE terminal/demo program.

Fax # 401-272-1273

Inquiry 688.

SOFTWARE/BUSINESS

DATA ENTRY SYSTEM

Heads-down data entry with two-pass verification for the IBM PS/2-PC/XT/AT & compatibles. Features include: Auto dup/skip, verify bypass, range checks, table lookups, a complete edit language. Fully menu driven. Price \$395

Call for our free 30 day trial period.

COMPUTER KEYES

21929 Makah Rd., Woodway, WA 98020

Tel: 206/776-6443 USA: 800/356-0203 Fax: 206/776-7210

Inquiry 689.

BLP88—LP w/BOUNDED VARIABLES

A general-purpose system aimed to LP88 for solving linear programs with up to 1000 constraints and 5000 bounded or unbounded variables. Build BLP88 into your own programs with compiled Turbo Pascal units. BLP88 reads/writes LOTUS worksheets. Use 1-2-Symphony as a matrix generator or post processor. Many other features including interactive and batch operation, spreadsheet LP display and editing, equation processor, problem/basis storage, primal/dual conversion, file I/O, Simplex restart, report generator, sensitivity analysis. \$149 with manual and 8087 support. \$299 with Turbo Pascal units.

Eastern Software Products, Inc.

P.O. Box 15328, Alexandria, VA 22309

(703) 360-7600

Inquiry 689.

THE BUYER'S MART

SOFTWARE/BUSINESS

LOW COST/HIGH QUALITY

Established, Powerful, Complete, Business Management Software Systems. Point-of-Sale/Inventory Control "SALES-PRO", Service and Repair, Video/Rental Store Management, Church Management, Accounting and Many more starting at \$39. For IBM PC Compatibles and the Atari ST.

HITECH ADVISERS

P.O. BOX 7524, Winter Haven, FL 33883-7524
1-800-882-4310 Florida (813) 294-1885

Inquiry 690.

SOFTWARE/CBASIC

CBASIC ENHANCEMENTS

We carry CB86, many enhancements to it, and MB86 (the best Cbasic to C available). MB86 is faster and more robust than CB86 itself with 100% conversion. Can be used as a replacement for CB86 with no knowledge of C. Limited free sample conversion available. We also have replacements for Access Manager and Display Manager.

Minnow Bear Computers

P.O. Box 2233 Sta. A, Champaign, IL 61825-2233
(217) 344-1113 Fax (217) 328-6127

Inquiry 691.

SOFTWARE/ENGINEERING

DATA ACQUISITION ON MS-DOS AT-VME

Our compiler ALLCON can handle software for processes up to 100 P/D reg and 100 PLC functions and 500 I/O in a realtime kernel. The system can be: A control, alarm, regulating and measuring system with timechannels, peak, states, and supervision functions. Introduction price: The first 100 orders ALLCON software and one Multif. card with 16 A/I (12 bit), 1 A/O, 16 D/I and 16 D/O with daughterboards. \$995.—for each CPU license

10 years exp. of computer
ALLregulator AB
415 09 Göteborg Sweden
Fax 46 31434730 tel 46 31480180 agents wanted

Inquiry 692.

PRACTICAL ENGINEERING TOOLS

Hobbyists — Students — Engineers
CIRCUIT DESIGN — LOGIC SIMULATION
FFT ANALYSIS — CIRCUIT ANALYSIS
MATHEMATICS — PC/MSDOS
VISA/MC
ALL UNDER \$50 — FREE CATALOG
BSoft Software (614) 491-0832
444 Colton Rd., Columbus, OH 43207

Inquiry 693.

Affordable Engineering Software

FREE APPLICATION GUIDE & CATALOG
Circuit Analysis • Root Locus • Thermal Analysis • Plotter Drivers • Engineering Graphics • Signal Processing • Active/Passive Filter Design • Transfer Function/FFT Analysis • Logic Simulation • Microstrip Design • PC/MSDOS • Macintosh • VISA/MC

BV Engineering Professional Software
2023 Chicago Ave., Suite B-13, Riverside, CA 92507
(714) 781-0252

Inquiry 694.

Digital Control Intro \$200
Digital Filter Tutor \$450
Kalman Filter Tutor \$925

Practical hands-on training courses that run on the IBM PC. Ideal alternative to text books, seminars, and university courses. FREE demo disk available.

Engineering Tutorial Software

22338 Lull Street, Canoga Park, Ca 91304
(818) 716-0816

Inquiry 695.

SOFTWARE/ENGINEERING

SIMULATION WITH GPSS/PC™

GPSS/PC™ is an IBM personal computer implementation of the popular mainframe simulation language GPSS. Graphics, animation and an extremely interactive environment allow a totally new view of your simulations. Simulate complex real-world systems with the most interactive and visual yet economical simulation software.

MINUTEMAN Software

P.O. Box 1717, Stow, Massachusetts, U.S.A.
(508) 997-5662 ext. 540 (800) 223-1430 ext. 540

Inquiry 696.

Circuit Analysis — SPICE

Non-linear DC & Transient; Linear AC.
* Version 3B1 with BSIM, GaAs, JFET, MOSFET, BJT, diode, etc. models, screen graphics, improved speed and convergence.
* PC Version 2G6 available at \$95.

Call, write, or check inquiry # for more info.

Northern Valley Software

28327 Rothrock Dr., Rancho Palos Verdes, CA 90274
(213) 541-3677

Inquiry 697.

ELECTRONIC TEMPLATES SCHEMATIC SYMBOLS

In Macintosh MacPaint format.
Hundreds of symbols including: common components, TTL, CMOS, linear & more.
Copy & Paste in seconds.
\$44.95 + \$3 S/H (CAL residents add 6%)

OASIS DESIGNS

61159 El Coyote Ln., Joshua Tree, CA 92252
619-366-8570

Inquiry 698.

FREE ENGINEERING MAGAZINE

Personal Engineering is a monthly magazine sent free of charge (USA only) to scientists/engineers who use PCs for technical applications. Topics each month include Instrumentation • Data Acq/Control • Design Automation. To receive a free sample issue and qualification form either circle below or send request on letterhead to:

Personal Engineering Communications
Box 300, Brookline, MA 02146

Inquiry 699.

EC-Ace ANALOG CIRCUIT ANALYSIS

You can afford to get started with EC-Ace, a subset of the powerful ECA-2 circuit simulator. Includes all the basics and built-in graphics.
• AC, DC, Temperature, Transient
• A full 525 pg. ECA-2 manual.
• Interactive, twice as fast as SPICE.

EC-Ace 2.31 IBM PC or Mac \$145.

Call 313-663-8810 for FREE DEMO

Tatum Labs, Inc.

1478 Mark Twain Ct., Ann Arbor, MI 48103

Inquiry 700.

68HC11 SIMULATOR

\$95.00

Test software written for the 68HC11 on an IBM/PC/XT/AT or 100% compatibles. Single stepping, trace mode, breakpoints, interrupts, disassembler, EPROM simulation, much more! Tool for students and professionals. Check/Visa/MC.
FAX (604) 294-9996 Bro hure available

WestShore Products

22548 Kendrick Loop, Maple Ridge, B.C. Canada V2X 9W4
(604) 291-1179

Inquiry 701.

SOFTWARE/FORECAST

FORECASTING PC/SIBYL™

The classic collection of business forecasting software. Fully revised & expanded: • 19 forecasting models • Faster • Easier to use • Full statistics • By Spyros Makridakis, internationally recognized forecaster. Two disk set now \$495 plus \$25 postage & handling; or \$20 for demo disk (credited toward purchase).

APPLIED DECISION SYSTEMS

33 Hayden Ave., Lexington, MA 02173
Call: (617) 861-7580

Inquiry 702.

SOFTWARE/FORTRAN

EXPAND & EXTEND LIBS

122 FORTRAN callable routines. EXPAND allows DOS compilers access to LIM/EMS 3.2 or 4.0 expanded memory. EXTEND provides CGA, EGA, VGA, Hercules, HP, Tektronix, Auto AD DXF graphics, access to BIOS/DOS functions plus additional utilities. EXPAND \$119, EXTEND \$149, both \$218.

DESIGN DECISIONS, INC.

P.O. Box 12884, Pittsburgh, PA 15241
(412) 941-4525

Inquiry 703.

FORTRAN77 PROGRAMMER'S ASSISTANTS FREE YOU FOR MORE CREATIVE WORK

ASSISTANT I—12 productivity tools (beautifier, checker, documenter, function maker, action chart, etc.) & a source library with 300 essential subroutines. (MS-DOS) \$245
ASSISTANT II—FORTRAN77-to-C translator with run-time library (source) & 4 C productivity tools. (MS-DOS) \$475 demo \$10. 30-day money back guarantee. ORDER NOW!!

MicroTools

1082 E. El Camino Real #5, Sunnyvale, CA 94087
(408) 243-7688

Inquiry 704.

SOFTWARE/GEOLOGICAL

GEOLOGICAL CATALOG

Geological software for log plotting, gridding/contouring, hydrology, digitizing, 3-D solid modelling, synthetic seismogram, fracture analysis, image processing, scout ticket manager, over 50 programs in catalog. Macintosh too! Please call, or write, for Free Catalog!

RockWare, Inc.

4251 Kipling St., Suite 595, Wheat Ridge, CO 80033 USA
(303) 423-5645

Inquiry 705.

SOFTWARE/GRAPHICS

PROFESSIONAL GRAPHICS FOR SCIENTISTS AND ENGINEERS PC/MSDOS • Macintosh

FREE 48 page Catalog

Linear/Log Scaling • Graphs with error bars • AUTO PLOT • BATCH Mode • Multiple Y-axes • Multiple data files • Auto/Forced Scaling • Full labeling • Built-in editor • 1-2-3 Interface • Curve fitting • Statistics • CGA, EGA & Hercules Compatible. 40 pen plotters supported.

BV Engineering Professional Software

2023 Chicago Ave., Suite B13, Riverside, CA 92507
VISA/MC (714) 781-0252

Inquiry 705.

CADpacs

Software Development Tools
For CAD and Graphics Programmers

• MATHpac • SPLINEpac • PLOTpac
• GEOMETRYpac • VIEWpac • SHAPEpac
• MATRIXpac

General 2D & 3D graphic and utility libraries for C. Each CADpac includes complete C source code, programmers manual, and sample programs. \$35 each CADpac + \$2 s/h.

DesTek, Inc.

Design Technology
P.O. Box 176, Kenmore, NY 14217

Inquiry 706.

THE BUYER'S MART

SOFTWARE/GRAPHICS

Technical Report Graphics

Edit data and graphics with EDTECH for \$65

- Database, worksheet-style data editing
- Technical XY plots from data for reports
- Graphics editing on screen, drawing, text
- 180x180 dots/inch output, 24-pin pin req'd
- Log axes, Greek, symbols, Lotus imp/ex

DIGITAL ANALYTICS

P.O. Box 31430, Houston, TX 77231
(713) 721-2069

Inquiry 707.

TurboGeometry Library

Over 150 2&3 dimensional routines, includes Intersections, Transformations, Equations, HiddenLines, Perspective, Curves, Areas, Volumes, Clipping, Planes, Vectors, Distance, PolyDecomp, IBM PC and Comp. MAC. MSDOS 2+. Turbo Pascal, Turbo C, MSC & Turbo Pascal MAC. 400 pg. manual, source code, \$149.95 + 5.00 S&H. Foreign add \$16.00. VISA, MC, Chk, P.O. 30 Day guarantee.

Disk Software, Inc.

2116 E. Arapaho Rd., #487, Richardson, TX 75081
1-800-635-7760
(214) 423-7288 FAX: 214-423-4465

Inquiry 708.

SEGS 2.0 Scientific Engineering Graphics System

- Logarithmic, Time/Date & Linear Axes.
- Easy Curve Fitting and Data Smoothing.
- 1-2-3 Interface & Numeric Spreadsheet.
- Supports all Video & Device Standards.
- 10 Curves with up to 8000 points each.

Edmond Software, Inc.

5900 Mosteller Dr. #1124 405-842-0558
Oklahoma City, OK 73112 800-284-3381

Inquiry 709.

PEN PLOTTER EMULATOR

FPLLOT turns your dot matrix or laser printer into an HP pen plotter. Fast hi-res output. No jagged lines. Vary line width, color. Works with Autocad, Drafix, etc. Supports NEC P5/P6, IBM Proprinter, Epson LQ/FX, Toshiba, HP Laserjet. Hercules/CGA/EGA/VGA for preview. \$64 check/m.o.

FPLLOT CORPORATION

24-16 Steinway St., Suite 605, Astoria, NY 11103
212-418-8469

Inquiry 710.

SCIENTIFIC POWER GRAPHICS

HGraph - graphics library, 100+ device independent routines for PC, SUN, Mac, VAX. Supports most graphics adapters, printers & plotters. Links with FORTRAN, Pascal, C, Modula-2 & Basic. \$19

UGraph - graphics presentation program. No programming; use your data or generate within. Special functions, FFT's, complex matrices. Designed for speed, ease of use; tailor to meet your needs! \$395
Custom software development.

HeartLand Software, Inc.

"Scientific Software Specialists"
234 S. Franklin • Ames, IA 50010 USA
• (515) 292-8216 •

Inquiry 711.

GRAPHICS PRINTER SUPPORT

AT LAST! Use the PrtSc key to make quality scaled B&W or color reproductions of your display on any dot matrix, inkjet, or laser printer. GRAFPLUS supports all versions of PC or MS-DOS with IBM (incl. EGA, VGA), Tecmar, and Hercules graphics boards. \$49.95.

Jewel Technologies, Inc.

4740 44th Ave. SW, Seattle, WA 98116
800-628-2828 x 527 (206) 937-1081

Inquiry 712.

SOFTWARE/GRAPHICS

FORTRAN PROGRAMMER?

Now you can call 2-D and 3-D graphics routines within your FORTRAN program.

GRAFATIC: screen routines \$135.
PLOTATIC: plotter driver 135.
PRINTATIC: printer driver 135.

For the IBM PC, XT, AT & compatibles. We support a variety of compilers, graphics bds., plotters and printers.

MICROCOMPATIBLES

301 Prelude Dr., Dept. B, Silver Spring, MD 20901 USA
(301) 593-0683

Inquiry 713.

GRAPHIC TOOLS LIBRARY

NOVA XGLIB: High speed. Window/lewpport, arcs, splines, figure fill, paint, borders, text scale/orient/align, bitmaps, bitblt, pens, keyboard, mouse, image capture. Over 150 functions. \$75. PC_VDI: Includes Segment, virtual mem. \$395. Both products ANSI CGI compatible, drivers for printer, plotter, HP laser. CGA/EGA/VGA. For most "C" compilers, MS FORTRAN, QuickBASIC. Demos, manual.

NOVA, INC.

P.O. BOX 68976, Schaumburg, IL 60168
312-882-4111

Inquiry 714.

AMAZING GRAPHICS MADE SIMPLE!

Announcing Axum, the first truly sophisticated technical graphics and analysis program for PCs.

- publication-quality color, 2D & 3D
- import Lotus/dB/etc, export to WP/PgMaker
- analyze, explore, display, customize
- intuitive menus, online help, interactive

TriMetrix, Inc.

(800) 548-5653 ext 063
444 NE Ravenna #210-BY (206) 527-1610 in WA
Seattle, WA 98115 (206) 547-0236 FAX

Inquiry 715.

SOFTWARE/HUMOR

THE HUMOR PROCESSOR

See "What's New" pg 88, BYTE November, 1988

The Humor Processor is a serious tool for creating jokes. Perfect for speech-writers, managers, & would-be comedians. Extensive cross-referenced database, pull-down menus. \$49.95 Call for info & free "How Not to Tell a Joke" Tip Sheet.

Responsive Software

1901 Tunnel Rd., Berkeley, CA 94705
• 1-800-669-4611 •

Inquiry 715.

SOFTWARE/INVESTMENT

Compare over 1,800 Mutual Funds with Business Week's Mutual Fund Scoreboard and your IBM PC or compatible. Use simple menu commands to search and sort on over 25 information fields. No additional software required. Data transports easily to Lotus 1-2-3. Search, total, average, rank, display and print reports—all at the touch of a key!

Only \$69.95 each for an Equity or Fixed Income Diskette
\$199.95 per subscription for either the Equity or Fixed Income version
\$319.90 for a subscription to both versions (a savings of \$80!)

Order now or receive more information by calling 1-800-553-3575
(in Illinois, call 1-312-250-9292)

Or write to: **Business Week Diskettes**
P.O. Box 621, Elk Grove, IL 60009

Inquiry 716.

STOCKS OPTIONS FUTURES

Turn Your PC Into A

MARKET QUOTATION MONITOR

85 page book covers satellite and radio data reception of financial news and quotes for your PC. \$19 (includes demo diskette). Free informative catalog of

- Data receivers and kits
- Quote processing and display software
- Descrambling software utilities

303-223-2120 \$2 Shipping & Handling

DATARx

111 E. Drake Rd, Suite 7041, Fort Collins, CO 80525

Inquiry 717.

SOFTWARE/LANGUAGES

FORTH with DRUMA FORTH-83

Break the 64K barrier without speed/space penalty. Well designed, attractively priced. '83 Standard.

- 1Mb+ automated memory management
- On-line documentation, ASCII/block files
- Many powerful and useful features
- Other products: windows, modules, profiler
- IBM PC/XT/AT & all compatibles

Write or call for FREE example diskette.

DRUMA INC.

6448 Hwy. 290 East E103, Austin, TX 78723
Orders: 512-323-0403 EBoard: 512-323-2402

Inquiry 718.

FORTRAN for Macintosh

Language Systems FORTRAN is a full-featured FORTRAN 77 compiler integrated w/MPW. Full ANSI FORTRAN 77 plus VAX-type extensions. SANE numerical calculations & data types incl. COMPLEX*16. 68000, 68020 and 68881 object code. Arrays greater than 32K. Link with Pascal, C, MacApp. \$359 w/MPW via air. MC/MISA/Check. MAC+, SE, Mac II. HD req.

Language Systems Corp.

441 Carlisle Dr. e, Herndon, VA 22070
(703) 478-0181

Inquiry 719.

SOFTWARE/MATHEMATICS

MATH EDITING FOR THE PC

$$x_i^2 = \sum_{k=0}^{\infty} [x_k^{2i} (\frac{1}{k})] + \left(\frac{\int F ds}{\sqrt{\alpha \pm \beta x}} \right)$$

- MathEdit constructs math equations to be inserted into WordPerfect and TeX documents.
- User-friendly interface—no new word processor needs to be learned
- MathEdit—\$149

K-TALK COMMUNICATIONS

50 McMillen Ave., Suite 100
Columbus, Ohio 43201
(614) 294-3535

Inquiry 720.

MATHEMATICIANS—ENGINEERS

Have you ever seen functions of a complex variable? Would you like to really understand differential operators like div, grad and curl? How about a peek into the fourth dimension? Call or write for information on our latest PC and Macintosh software.

Lascaux Graphics

3220 Steuben Ave., Bronx, NY 10467
(212) 654-7429

Inquiry 721.

SOFTWARE/MUSIC

COMPLETE MUSIC SELECTION

Songwriters, arrangers, teachers and musicians. Explore the options of a MIDI set up. All computers supported with the largest selection of software and hardware for various applications.

- Recording/Sequencing • Sound Editors
- Publishing • Cables • Computer-Aided Composition
- Education • Interfaces • Voices

Write for free catalog or call for free consultation.

MIX BOOKSHELF

6400 Hollis St., #12, Emeryville, CA 94608 (415) 653-3307
1-800-233-9604

Inquiry 722.

The ENTER-tainer Clip Music & Utility

300 Songs & Sound Effects - FUN & Educational

By far the biggest & best collection on the market for DOS machines. Play like a jukebox through your PC speaker or clip & distribute in your own programs. BASIC source code included—no royalties required. Info-packed 172-page manual. 5.25" or 3.5" disks. Requires BA IC 2.0 or later. \$29.95+\$3.50 S&H MC/MISA/M.O. Money Back Guarantee!

PDI Music Software

P.O. Box 18655, Boulder CO 80308
(800) 727-4140 In Colorado (303) 440-4140

Inquiry 723.

THE BUYER'S MART

SOFTWARE/PACKAGING

HARD TO FIND COMPUTER SUPPLIES FOR SOFTWARE DEVELOPERS & POWER USERS

Cloth binders & slipcases like IBM's. Vinyl binders, boxes, and folders in many sizes. Disk pages, envelopes, & labels. Low quantity imprinting. Bulk disks. Everything you need to bring your software to market. Disk and binder mailers. Much more! Low Prices! Fast service. Call or write for a FREE CATALOG.

Anthropomorphic Systems, Limited
376-B E. Saint Charles Rd., Lombard, IL 60148

1-800-DEAL-NOW 312-629-5160

Inquiry 724.

SAVE SAVE SAVE SAVE LET'S TALK LABELS

We do disk labels (5 1/4" & 3 1/2")

• Better • Faster • Cheaper •

Because we specialize in disk labels... Let's Talk

We also have Tyvek Sleeves

Mailers • Binders • Vinyl Pages

We are a complete software packaging service.

Hice & Associates

9303 Cincinnati-Columbus Rd., West Chester, OH 45069
513-777-0133

Inquiry 725.

SOFTWARE/PRINTER

PRINTER GENIUS

Powerful memory resident printer management • Control printer features from menus or within documents • Print spool to disk files or memory • Background print • File & directory browse • Edit small text • and more... • User friendly pop-up screens • 92 page manual • Preset for all printers • Completely flexible • PC MS-DOS • \$89 + \$4 S/H • VISA/MC

Nor Software Inc.

527 3rd Ave., Suite 150, New York, NY 10016
(212) 213-9118

Inquiry 726.

SOFTWARE/SCANNERS

Optical Character Recognition

Stop retyping: PC-OCR™ software will convert typed or printed pages into editable text files for your word processor. Works with HP ScanJet, Panasonic and most other scanners. Supplied with 18 popular fonts. User trainable: you can teach PC-OCR™ to read virtually any typestyle, incl. foreign fonts. Proportional text, matrix printer output, Xerox copies OK. \$385. Check VISA/MC/AmExp/COD

Essex Publishing Co.

P.O. Box 391, Cedar Grove, NJ 07009
(201) 783-6940

Inquiry 727.

SOFTWARE/SCIENTIFIC

DATA ACQUISITION & ANALYSIS ON PC'S

• Free application assistance. Tell us about your DSR, process control, A/D or DA needs. Our expert engineering staff will provide you with a system solution to fit your needs and budget.

• A/D & IEEE 488 boards from Metrabyte, Scientific Solutions and National Instruments.

• Analysis software including PRIME FACTOR FFT subroutine library, FOURIER PERSPECTIVE II advanced linear systems analysis.

• Menu driven software from Unitek, Laboratory Technologies, Quinn-Curtis, and Golden. Scientific engineering 2 & 3D graphics.

See "What's New" page 80, BYTE July, 1988

LOW PRICES—Satisfaction GUARANTEED

ALLIGATOR TECHNOLOGIES

P.O. Box 9706, Fountain Valley, CA 92708
Tel. (714) 850-9984 FAX. (714) 850-9987 MCI. ALLIGATOR

Inquiry 728.

POWERFUL EQN SOLVER

RISK FREE \$99 OFFER With Top 10 Word Processor!

"Simple to differentiate or integrate." SCI.Soft

Graph across singularities • Non Linear • Coupled (singular) diff eqn • Any order any number • Indefinite (singular) integrals • New functions/algorithms/solutions • Fit 60th order curves to imported data

• COMPLEX real roots • Programming • 47 predefinitions • 14 digit accuracy • More • Data over 40 years' EETimes • MS-DOS, 640KB, graphics card • CURVE

CALL TODAY • 800-648-5353 x100

VISA/MC/COD/Check

Curve Systems International

11693 San Vicente Blvd., Suite 350, L.A., CA 90049

Inquiry 729.

SOFTWARE/SCIENTIFIC

Chaos/Nonlinear Dynamics

Tools for Studying Mathematical and Experimental Systems

• Ordinary and Delay Differential Equation Solvers • Bifurcation Diagrams • 2- and 3-D Plotting, Sequential Magnification, Poincaré Sections • Next Maximum, 1-D & Circle Maps • Phase Portraits with Multiple Initial Conditions • Spectral Analysis, Fractal Dimensions, Lyapunov Exponents

DS1 \$2500 DS-II \$3500

DYNAMICAL SYSTEMS, INC.

P.O. Box 35241, Tucson, AZ 85740, 602-825-1331

Inquiry 730.

C SCIENTIFIC LIBRARY

Extensive library of matrix, mathematical, and statistical routines. Developed and documented for use by technical specialists and C programmers in research, education, engineering, and scientific applications. Over 550 functions, superior documentation—four manuals, including Tutorial, Function Pages, and Example Programs. Includes Real and Complex linear Algebra, Eigensystems, Differential Equations, Quadrature, Smoothing, Filtering and Prediction, Multivariate Statistics, Multi-Dimensional Optimization, Linear Programming, Curve Fitting and Interpolations, etc. \$295 object only and \$395 with C source code.

EIGENWARE TECHNOLOGIES

13090 La Vista Dr., Saratoga, CA 95070 (408) 867-1184

Inquiry 731.

OUR CATALOG WILL SAVE YOU TIME AND MONEY!

It describes (i) GRAPH, a \$79 scientific plotting program, (ii) MINSQ, a powerful \$179 package for curve fitting and model development, (iii) LAPLACE, a simulation program employing numerical inversion of transforms (\$249), and (iv) RSTRIP for exponential stripping (\$249). Call today for our free 16 page catalog with detailed technical application notes.

MicroMath Scientific Software

Salt Lake City, Utah 84121-3144

For orders or catalogs call: (800) 942-MATH

Inquiry 732.

ORDINARY/PARTIAL DIFFERENTIAL EQN SOLVER

FOR THE IBM PC & COMPATIBLES

MICROCOMPATIBLES INC.

301 Prelude Dr., Silver Spring, MD 20901

(301) 593-0683

Inquiry 733.

Scientific/Engineering/Graphics Libraries

Turbo Pascal, Turbo C, Microsoft C

Send for FREE catalogue of software tools for Scientists and Engineers. Includes: Scientific subroutine libraries, device independent graphics libraries (including EGA, HP plotter and Laserjet support), scientific charting libraries, 3-D plotting library, data acquisition libraries, menu-driven process control software. Versions available for a variety of popular languages.

Quinn-Curtis

1191 Chestnut St., Unit 2-5, Newton, MA 02164

(617) 965-5660

Inquiry 734.

SUBPROGRAM LIBRARIES

Five volumes of source code: Math, Statistics, Graphics, DOS & BIOS & I/O functions. Spectroscopy. Up to 99% less user code with our fully tested library. Manuals with examples guarantee fast success. Portability insured for BASIC, PASCAL under MS-DOS, Mac-OS, VMS, HP300. Prices start \$145 per volume. 30 day \$ back. VISA/MC/PO.

Scientific LOGICS Inc.

21910 Alcazar Ave., Cupertino, CA 95014

(408) 446-3575 Compuserve 74017,663

Inquiry 735.

SOFTWARE/SECURITY

CodeSafe™ Virus Protection System

Thousands of copies in use since 1986 • Protects all hard disks, any size • Protects all COM and EXE files. Not just the system files (like other products) • Detects corruption of Boot sector, and DOS • Supports all PC/MS DOS machines • DOS 2.0 to 4.0 • Mono, Herc, CGA, EGA • Includes both 5 1/4" and 3 1/2" disks • Transparent to user • Warning windows will open, with options if a problem occurs • Memory resident approx. 10 to 20 K, depending on the number of files.

TOLL FREE TECH SUPPORT @ 30 Day Money Back Guarantee

NOT COPY PROTECTED \$69.95 Visa and Master Card accepted

ChrisWare, Inc.

15415 N. Eden Dr., Eden Prairie, MN 55346

24 HOUR SERVICE TOLL FREE 1-800-325-8448

Inquiry 736.

HANDS OFF THE PROGRAM®

- Locks Hard Disk - Restricts Floppy Use.
- Protects Subdirectories.
- Normal Use of DOS Commands and Application Software.
- IBM PC, XT, AT and True Compatibles.
- DOS V2.0 and Higher. Hard Disk System.
- Keep Other People's HANDS OFF Your System
- \$89.95 VISA/MC

SYSTEM CONSULTING, INC.

314 Canterbury Dr., Pittsburgh, PA 15238

(412) 963-1624

Inquiry 737.

SOFTWARE/SORT

OPT-TECH SORT/MERGE

Extremely fast Sort/Merge/Select utility. Run as an MS-DOS command or CALL as a subroutine. Supports most languages and filetypes including Btrieve and dBASE. Unlimited filesize, multiple keys and much more! MS-DOS \$149. XENIX \$249.

(702) 588-3737

Opt-Tech Data Processing

P.O. Box 678 - Zephyr Cove, NV 89448

Inquiry 738.

SOFTWARE/TOOLS

CodeView in 8K

MagicCV runs Microsoft's CodeView debugger in less than 8K of conventional memory on an 80386 PC. CVW ver ion available too.

MagicCV \$199

Nu-Mega Technologies

P.O. Box 7607 • Nashua, NH • 03060-7607

(603) 888-2386 FAX 888-2465

Inquiry 739.

STATISTICS

SX STATISTIX

PC Magazine Editors Choice!

• Easy to learn and use • Fast Free Support

• Money Back Guarantee

At \$179 SX outperforms higher priced programs!

If you value your time and money,

call today for FREE SX demo disk

612-631-2852

Analytical Software Box 13204, Roseville, MN 55113

Inquiry 740.

The BASS System™

Why use up 8 meg and 640K just to run a data step on your PC? Now you can run your data step code and statistical procs with a system that takes only 1 meg and 400K (and costs only \$399)! Free information:

BASS Institute, Inc.

P.O. Box 349, Chapel Hill, NC 27514

(919) 933-7096 or BB: (919) 968-6755 (N,8,1)

Inquiry 741.

THE BUYER'S MART

STATISTICS

Go with SOLO

Statistics and graphics for the PC. Quick and easy to use. All the popular statistics plus the latest in graphics. For business professionals for occasional use, researchers for basic statistics, or students. Satisfaction guaranteed! \$149 complete with graphics. Call today. VISA or MC.

BMDP Statistical Software, Inc.
1440 Sepulveda Blvd., Suite 316, Los Angeles, CA 90025
(213) 479-7799

Inquiry 742.

STATA

NEW RELEASE NOW AVAILABLE. Even better graphics, expanded on-line help, and much more. Still only \$590. Quantity and Academic Discounts available. \$20 Demo. Call toll-free for more information. AX/VISA/MC.

1-800-STATAPC
Computing Resource Center
10801 National Boulevard, Los Angeles, CA 90064
(213) 470-4341

Inquiry 743.

THE SURVEY SYSTEM

An easy-to-use package designed specifically for questionnaire data. Produces banner format, cross tabs & related tables, statistics (incl. regression) & bar charts. Codes and reports answers to open-end questions. All reports are camera-ready for professional presentations. CRT interviewing option.

CREATIVE RESEARCH SYSTEMS
15 Lone Oak Ctr., Dept. B, Petaluma, CA 94952
707-765-1001

Inquiry 744.

STATISTICS CATALOG!

Call for the catalog full of professional programs for general statistics, analysis of variance, regression, questionnaire analysis and quality control. Thoroughly tested and easy to use, the programs come with complete documentation. Programs available for PC or Apple II. Call toll free now for your free catalog.

HUMAN SYSTEMS DYNAMICS
9010 Reseda Blvd., Suite 222
Northridge, CA 91324
(800) 451-3030 (818) 993-8536 (CA)

Inquiry 745.

STATISTICAL NAVIGATOR™

Statistical Navigator an expert system using AI strategies to help guide the researcher to the appropriate statistical analysis. Based on your answers, it suggests several analyses ranked by suitability. It explains what the analysis does and how it fits your objectives and assumptions. Special intro price \$99.95 + s/h.

VISA/MC/AMEX/PO, 30 day-guarantee.

The Idea Works, Inc.
100 West Briarwood, Columbia, MO 65203
1-800-537-4866 314-445-4554

Inquiry 746.

SIR/DBMS DEMO KIT (7.5 Mb) \$49.95

Since 1976, SIR/DBMS has PIONEERED Advanced DBMS Technology DESIGNED to handle the changing complexities of Scientific, Engineering, and Research Database Management. SIR/DBMS is also DESIGNED to Provide THE BEST DIRECT Interfaces to SAS, SPSS, BMDP, & SYSTAT. SIR/DBMS offers True Application Level Portability from PCs thru Supercomputers!

MAYBE YOU SHOULD TRY SIR/DBMS??
Order Now! Ref Buyer's Mart Special Offer!

SIR, A Division of Inter Systems Inc.
312-480-9270 (IL) 703-642-1600 (VA)

Inquiry 747.

STATISTICS

MINITAB's a PC of cake!

MINITAB's intuitive commands are easy to use and remember. Features descriptive statistics, regression, time series, chi-square, hi-res graphics, much more. PC version incl. LOTUS interface, data editor, network pricing. Call for FREE brochure.

Minitab, Inc.
3081 Enterprise Dr., State College, PA 16801
(814) 238-3280

Inquiry 748.

NCSS

Professional, easy to use, menu driven statistical system. Used by over 5,000 researchers.

- 5.0 Statistical System —\$99
- 5.1 Graphics (2D & 3D)—\$59
- 5.3 Power Pac Supplement—\$49
- 5.4 Exp. Design/QC—\$49
- 5.5 Survival Analysis—\$59
- 5.6 Forecasting—\$69

We accept checks, PC's, Visa, MC. Add \$3 s/h.
NCSS-B 801-546-0445
865 East 400 North, Kaysville, UT 84037

Inquiry 749.

SCA STATISTICAL SYSTEM

The only statistical software encompassing Forecasting & Time Series Analysis Quality and Productivity Improvement General Statistical Analysis

Available on both DOS and OS/2 operating systems.
Call today for more information

Scientific Computing Associates
4513 Lincoln Ave., Suite 106, Lisle, IL 60532, USA
Phone: (312) 960-1698 FAX: (312) 960-1815

Inquiry 750.

StatPac Gold™

StatPac Gold is the award-winning statistics and forecasting package that delivers. It's fast, flexible, easy to use and dependable. Time-tested and loaded with features. You be the judge. Get the facts! Call for your FREE brochure.

1-800-328-4907
Walonick Associates, Inc.
6500 Nicollet Ave. S., Minneapolis, MN 55423
(612) 866-9022

Inquiry 751.

UTILITIES

Class-A-File

A database for your DOS files. Automatically tracks last access, update, and creation dates. You classify each file, specify ownership, attributes and description using pop-up interface accessible from any program. Class-A-File sorts and reports according to your selection. Like adding secondary keys to the DOS files system. \$69.95.

Automation Technology Research
4790 Irvine Blvd. #105-376, Irvine, CA 92720
(714) 838-6607

Inquiry 752.

BETTER PRINTER CONTROL

PRINTSELECTOR provides a menu of printer functions & embeds printer control inside documents. Its better because menu controlled menu generators allow you to customize embedded controls and menus for your printer and your needs.

MSDOS 5.25" only \$50.00+\$4.00 S/H+6.5% sales tax in CA
to order or receive info:

Brook King Systems
10064-7 Larwin Ave., Chatsworth, CA 91311
(818) 882-8451

Inquiry 753.

UTILITIES

MATCH PRINTERS TO PC

For less than \$30 MatchFont and Match-a-Printer are great for foreign and scientific writings. Get all the characters you need from most programs and printers (Apple & Epson printers, daisywheels, etc.). Greek, French, Italian, Spanish, German, Swedish, Japanese, graphics... You name it! To receive a demo disk send \$5 refundable upon purchase to:
Call or write 818-906-6791

MATCH SOFTWARE
6426 Coldwater Canyon, North Hollywood, CA 91606-1113

Inquiry 754.

BRIDGE-IT 3.5

This device driver supports 3 1/2" drives in both 720K and 1.44mb capacity on PC/XT/AT model compatibles without upgrading DOS or changing BIOS. Bridge the gap to PS/2 and laptop systems.
Only \$59 + \$4 S/H VISA/MC/COD UPS B/R

MICROBRIDGE COMPUTERS
655 Sky Way, San Carlos, CA 94070
ORDER TOLL FREE 1-800-523-8777
415-593-8777 CA FAX 415-593-7675
514-845-0818 (CAN)

Inquiry 755.

COPY AT TO PC

The 1.2mb drive has long been known to READ but NOT reliably WRITE on 360kB floppies. With "CPYAT2PC"™ 1.2mb drives CAN reliably WRITE 360kB floppies saving a slot for a second hard disk or backup tape. "CPYAT2PC" (Not Copy Protected) offers "the preferable SOFTWARE SOLUTION." ONLY \$79+\$4 S/H VISA/MC/COD UPS B/R

MICROBRIDGE COMPUTERS
655 Skyway, San Carlos, CA 94070
Order toll free 1-800-523-8777
415-593-8777 (CA) FAX 415-593-7675
514-845-0818 (Canada)

Inquiry 756.

PC-REFERENCE

The best computer publications on-line index. Find articles by keyword, date interval, author, title, publication, type (article, review, etc.) or any combination. Our packing method gets more info into smaller files. Written in optimized C and assembler for speed and compactness. Byte, PC Mag, Personal Computing, PC Computing, PCTJ, more—get just the ones you want. As low as \$49.95 per year.

Nova Software
Box 37464 • Albuquerque, NM 87176
(505) 836-8400

Inquiry 757.

Recover deleted files fast!

Disk Explorer now includes automatic file recovery. You type in the deleted file's name, Disk Explorer finds and restores it. Disk Explorer also shows what's really on disk; view, change or create formats, change a file's status, change data in any sector. MS-DOS \$75 U.S. Check/Credit card welcome.

QUAID SOFTWARE LIMITED
45 Charles St. E. 3rd Fl.
Toronto, Ontario, Canada M4Y 1S2
(416) 961-8243

Inquiry 758.

XPage Breaks 640k!

Why buy expensive EMS boards? OS/2 is not going to use it. XPage turns your PC/XT/AT hard disk space or AT extended memory as EMS memory. It's compatible with most DOS EMS applications. Write for free information or send check/money order \$39 + \$3 s/h to:

RMC Technologies
7 Baron Park La., #21, Burlington, MA 01803
(617) 272-8208

Inquiry 759.

THE BUYER'S MART

UTILITIES

ARABISE YOUR PC!

The ARAB KIT package converts your PC to a fully bilingual Arabic/Latin system. Run popular software (Lotus 1-2-3, dBase III+, etc.) in English AND/OR Arabic, with on screen Arabic characters and NLO printing. ARABKIT comes with a free copy of ALBAYAN, a dedicated and powerful bilingual word processor.

EGA version-\$299 MONO version (inc Mono card)-\$349
Add 15% VAT if ordering in U.K.

ROCKETFIELD COMPUTER SYSTEMS

86 Birch Hall Lane, Manchester M13 0XZ, U.K.

Tel: 061-224 4032 FAX: 061-256-3279

Inquiry 760.

DATABASE UTILITIES

NORTAK Software Ltd. now offers a menu-driven ASSIST-like file utility for dBASE, Clipper, and FoxBASE. Self-contained (.EXE file), fast and simple to use.

SINGLE VERSION—\$35; 3-VERSION PACKAGE—\$60.
To order call:

SHOSHIN Systems Inc.

USA 1-800-267-0755 Canada 1-800-267-8856

Info Only 613-235-2310

VISA and MC accepted

Inquiry 761.

LOGGER®

Logger, for IBM-PC and compatibles, tracks and reports: User, Time on, Time off, Directories used, Programs used, Program start/end time, and calculates totals. Tracks directories/files: Opened, Created, Renamed, Deleted. Completely transparent. Retails for \$74.95 with quantity discounts available.

System Automation Software, Inc.

8555 16th St., Silver Spring, MD 20910

1-800-321-3267 or 1-301-565-8080

Inquiry 762.

UTILITIES

\$79.95!!

Order the RED Utilities now! Programs include: Disk cache speeds hard and floppy disks. Printer spooler. Batch file compiler speeds batch files. Path command for data files. Wild card exceptions. Sort directories. Over 10 more programs. IBM PC. Visa/MC. Send for free catalog.

The Wenham Software Company

5 Burley St., Wenham, MA 01984 (508) 774-7036

Inquiry 763.

WORD PROCESSING

FARSI / GREEK / ARABIC / RUSSIAN

Hebrew, all European, Scandinavian, plus either Hindi, Punjabi, Bengali, Gujarati, Tamil, Thai, Korean, Viet, or IPA. Full-featured multi-language word processor supports on-screen foreign characters and NLO printing with no hardware modifications. Includes Font Editor. \$355 dot matrix; \$150 add'l for laser; \$19 demo. S/H in U.S. incl'd. Req. PC, 640K, graphics. 30 day Guarantee. MC/VISA/AMEX

GAMMA PRODUCTIONS, INC.

710 Wilshire Blvd., Suite 609, Santa Monica, CA 90401
213/394-8622 Tlx: 5106008273 Gamma Pro SNM

Inquiry 764.

JAPANESE WORD PROCESSOR FOR IBM

EW Plus is the first complete Japanese word processor for IBM PS/2 and AT. Contains about 8000 KANJI and KANA characters, as well as a 45000 word dictionary. Fully supports Japanese standards. Powerful Roma-ji to KANJI conversion. For IBM PS/2, AT, Toshiba laptops. Requirements: VGA, EGA, Hercules; 512k Memory; Hard Disk. Printers: Epson LQ 24 dot; IBM 9 pin, XL24; HP LaserJet.

For details call:

Information Technology Lab., Inc.

280 Park Ave., 4E, New York, NY 10017

TEL (212) 557-0177 FAX (212) 557-0179

Inquiry 765.

WORD PROCESSING

DuangJan

Bilingual word processor for English and: Armenian, Bengali, Burmese, Euro/Latin/African, Greek, Gujarati, Hindi, Khmer, Lao, Punjabi, Russian, Sinhalese, Tamil, Telugu, Thai, Ukrainian, Viet. . . . Only \$109+\$5 s/h (foreign + \$12 s/h). Font editor included. For any IBM compatibles with dot-matrix & LaserJet printer. Demo \$9+\$1 s/h.

MegaChomp Company

3438 Cottman Ave., Philadelphia, PA 19149-1606

(215) 331-2748 FAX: (215) 331-4188

Inquiry 766.

ELECTRONIC FILE SHREDDER AVAILABLE TO PUBLIC

Absolute security. Program totally erases sensitive files while leaving all other files intact. Eliminates deleted files on any size hard or floppy drive. Data CAN NOT be re-created by ANY utility. IBM or Compatibles. Perfect for legal, financial, military applications. \$89. Meets DoD Spec# 5220.22. VISA/MC

ProWest Inc.

4313 Lomas Blvd. NE, Albuquerque, NM 87110

1-800-825-8375

Inquiry 767.

PC-Write 3.0 — Shareware

Fast, full featured word processor for IBM PC. Now edits large files & multiple columns. Also spell check, mailmerge, networking, ASCII, and macros. Easy to use, optional menus. Supports 500 printers incl. lasers. Software, guide and tutorial on disk: \$16. Registration with manual, support newsletter and 2 free updates: \$89.

90 day money back guarantee. VISA/MC.

Quicksoft

1-800-888-8088

219 First Ave. N., #224-BYTC, Seattle, WA 98109

Inquiry 768.

BBS Sysops

Are you looking for ways to improve your board? Something that will set you apart from other boards in your area? Are your subscribers interested in Microcomputers? Listen to this!

Announcing the Bulletin Board EXchange - BBX

The BBX allows you to become a publisher of MicroBYTES Daily, an on-line news service from BYTE.

BBX/MicroBYTES is a custom package of news and features designed specially for local BBSes, and is available only to sysops.

Every Monday through Friday you get articles about developments in microcomputing, telecommunications and selected new product announcements. Get the latest news about MS DOS machines, Macintoshes, Unix workstations, Amigas, Atari STs, peripherals and software. All the stories are reported, written, and edited by the staff of BYTE Magazine, BYTEweek and BIX, and our world-wide network of reporters and editors.

Not only do you get a great resource for your subscribers, but you also get access to BIX which will cut your cost of exchanging information and conducting BBS network business.

All this is just \$49 a quarter. Your one-year subscription to the BBX (billed quarterly) may be cancelled any time without further charge; just notify us. If you prefer, you may subscribe for three months only, at just \$69.

If you call BIX directly, you pay no hourly telecommunications charge. If you call using Tymnet, the rates are only \$2/hour on evenings and weekends and \$8/hour on weekdays. You may also purchase unlimited off-peak Tymnet for just \$15 a month

Subscribe today.

BIX

One Phoenix Mill Lane

Peterborough, NH 03458

1-800-227-2983 In NH (603) 924-7681

Save Your Data and Money, Too! Peripherals Sale!

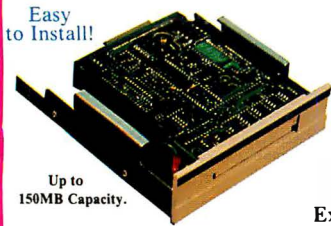

Easy to Install!

Up to 150MB Capacity.

This is the fastest floppy interface tape drive around!

60MB TAPE DRIVES

Add \$10 for Shipping **\$279** 40MB Tape \$22
60MB Tape \$30

External model now available for only \$99 extra!

Works on PC, XT, AT's and 100% compatibles. Connects to the internal floppy (B:) connector or the optional adapter card (\$77). Comes complete with

installation instructions and data compression software that allows up to 100MB data storage on a 40MB tape — 150MB on a 60MB tape.



Total Power Protection!

UNINTERRUPTABLE POWER SUPPLY

As Low As **\$279** 250 Watt Model
Add \$23 shipping in the lower 48 states.

| | | |
|-----------|----------|--------|
| 250 Watt | 120 Volt | \$ 279 |
| 300 Watt | 120 Volt | 399 |
| 500 Watt | 120 Volt | 499 |
| 600 Watt | 120 Volt | 639 |
| 1200 Watt | 120 Volt | 1099 |
| 1600 Watt | 120 Volt | 1444* |

230 volt units also available. *Shipped motor freight collect. Specify exact input voltage.

Protects Against

- Brownouts.
- Blackouts.
- Overvoltage.
- Overload.
- Spills / Surges
- EMI

Features

- Two Audible Alarms.
- LED Displays.
- Optional Network Port.
- Transfer Times As Fast As 1 Millisecond (Depends on Model).

Save on Low Cost Floppys!

Select the drive or drives you want, pick the enclosure and appropriate cable and we will assemble and test at no additional cost to you. All drives are brand new, not factory seconds, and carry a full one year parts and labor warranty. Add \$5 shipping and handling per drive.

| | |
|--|-------|
| 360K 5.25" TEAC 55B bare | \$ 79 |
| 720K 5.25" TEAC 55F bare | 85 |
| 1.2M 5.25" TEAC 55FGH bare | 85 |
| 360K 3.5" TEAC 35B bare | 119 |
| 720K 3.5" TEAC 35F bare | 85 |
| 1.44M 3.5" TEAC 35FGH bare | 85 |
| 5.25" mounting bracket for 3.5" drives | 18 |
| (Includes rails, signal & power adapter. Specify beige or black faceplate) | |

| | |
|--|------|
| Dual 3.5" external case / power supply. Use with one or two 3.5" drives (horizontal) | \$49 |
| Dual 5.25" same as above except vertical | 59 |
| IBM external floppy cable for C/D. DB37 required | 39 |
| (Add \$10 for brushed Stainless Steel cover) | |



Get the Best for Less!

Limited Time Only! Fantastic Prices Now On LOW COST HARD DRIVES For IBM and Tandy

5.2MB 95ms ST-506 MFM XT Kit **\$149** 21.4MB 65ms ST-225 MFM XT Kit **\$259**

32.7MB 65ms ST-238 12LL XT Kit **\$289** 42.8MB 40ms ST-251 MFM XT Kit 28ms Optional **\$399**

\$399 49.1MB 40ms ST-157R RLL Bare 28ms Optional **\$479** 65.5MB 40ms ST-277R RLL XT Kit 28ms Optional **\$599** 80.2MB 28ms ST-4096 MFM Bare **\$599** 84.9MB 28ms ST-296N SCSI Kit **\$699** 122.7MB 28ms ST-144R RLL Bare

Add \$10 for shipping.

We provide the best low cost, high quality, fast access hard drives for your IBM, 100% compatible or Tandy computer. Our XT and SCSI kits are complete with drive, controller, cables and installation instructions. We use only brand new genuine Seagate drives so you can be assured of long trouble-free drive life. Data transfer rates as fast as 500KB per second MFM, 800KB RLL and 1MB using SCSI.

We provide software to park the heads (some drives self-park). Tandy 1000 requires DMA and ROM 1.01+. Not for EX/HX. Please specify the computer brand and model when ordering. ST 506, 4096 and 4144R are full size 5 1/2", ST 157R is 3 1/2". All others are half height 5 1/4". Sizes listed are after formatting. One year parts and labor warranty. Satisfaction guaranteed or your money back, less shipping.



Hurry! Supply Limited

Save on 32MB & 49MB Hard Cards

32.7MB 48ms RLL **\$329** 49.1MB 40ms RLL **\$489**

These units are completely assembled with brand new drives and come ready to install. For IBM XT's, 100% compatibles and Tandy 1000/1000A, SL, SX, TL, TX. Please specify the exact make and model of your computer. One year parts and labor warranty.

SOFTWARE SPECTACULAR! SENSATIONAL SAVINGS!

This list is only a small portion of our inventory! Call us for your software needs!

MS-DOS® BUSINESS SOFTWARE

| | |
|---|-------|
| Allways | \$ 92 |
| Borland Quattro (1-2-3 Clone) | 169 |
| Borland Sprint: The Work Processor | 138 |
| DAC Easy Accounting (all version 3) | 123 |
| DAC Easy Bonus Pack | 61 |
| DAC Easy Payroll | 61 |
| dBase III Plus | 439 |
| dBase IV | 499 |
| Desqview | 79 |
| Desqview 386 | 116 |
| Formtool | 55 |
| Framework III | 399 |
| Generic Cadd, Level 1 | 28 |
| Generic Cadd, Level 2 | 55 |
| Harvard Graphics | 299 |
| Lotus 1-2-3 2.01 | 319 |
| PageMaker 3.0 | 134 |
| Peachtree Complete System II | 529 |
| pe: First Choice | 174 |
| pe: First Publisher | 99 |
| pe: Professional File with Report | 83 |
| pe: Professional Plan | 169 |
| pe: Professional Write | 62 |
| Printshop Bundle | 125 |
| Printshop Companion | 37 |
| Publish It! | 31 |
| Q & A | 122 |
| | 229 |

| | |
|------------------------------|-------|
| Quicken | \$ 31 |
| Rightwriter | 52 |
| Ventura Publisher 2.0 | 529 |
| WordPerfect 5.0 | 255 |
| WordStar Pro Release 5 | 248 |

OTHER MS-DOS SOFTWARE

| | |
|--|------|
| Chess Master 2100 | \$32 |
| F-19 Stealth Fighter | 43 |
| Kings Quest I, II, III or IV | 31 |
| Leisure Suit Larry | 26 |
| Leisure Suit Larry II | 30 |
| Managing Your Money | 129 |
| Mavis Beacon Teaches Typing | 33 |
| Math Blaster Plus | 28 |
| Microsoft Flight Simulator | 37 |
| Reader Rabbit | 26 |
| Test Drive | 22 |
| Typing Tutor IV | 31 |
| Where in Europe is Carmen San Diego? | 28 |
| Where in U.S.A. is Carmen San Diego? | 28 |
| Where in World is Carmen San Diego? | 25 |

MS-DOS LANGUAGES/UTILITIES

| | |
|--|-------|
| AutoSketch | \$ 53 |
| Borland Sidekick Plus | 138 |
| Borland Turbo BASIC | 69 |
| Borland Turbo C | 104 |
| Borland Turbo PASCAL with 8087/BCD | 103 |
| Carbon Copy + (need two copies) | 119 |
| Copy II PC | 21 |

| | |
|--------------------------------------|-------|
| Copy II PC Option Board Deluxe | \$116 |
| Fastback Plus | 115 |
| Grammatik III | 54 |
| Laplink Plus | 84 |
| Microsoft Macro Assembler 5.1 | 99 |
| Microsoft Quick BASIC Compiler | 67 |
| Microsoft Quick "C" Compiler | 67 |
| Microsoft Windows 286 | 67 |
| Microsoft Windows 386 | 133 |
| Norton Utilities 4.5 Advanced | 79 |
| PC Tools Deluxe 5.0 | 45 |
| Procomm Plus | 46 |
| Sideways | 42 |
| X Tree Pro | 69 |

BOOKS

Take advantage of our volume discounts and save a bundle! Buy any 3 books and earn an additional \$3 discount. Buy 4 and deduct \$4. Buy 5, deduct \$5, etc.

| | |
|--------------------------------------|------|
| Using 1-2-3, Special Edition | \$19 |
| dBase III Plus Handbook | 17 |
| dBase IV Handbook | 16 |
| Managing Your Hard Disk | 16 |
| MS-DOS Users Guide 3rd Edition | 17 |
| Running MS-DOS | 17 |
| Using AutoCad | 21 |
| Using Managing Your Money | 15 |
| Using Paradox | 17 |
| Using Q & A | 16 |
| Using WordPerfect 4.2 | 16 |
| Using WordPerfect 5 | 19 |



Reg. U.S. Pat. Off.



ORDER TOLL FREE!

Mon.- Fri. 9-7; Sat. 10-3

Call from anywhere in the lower 48 states and Hawaii.

1-800-527-0347



AD M6

HIGH QUALITY...LOW PRICE!

We've Built Our Reputation on This Premise for Almost a Full Decade.

Clone 286 With
LOW PRICE

\$1299



10MHz, 30MB HARD DRIVE,
MONOCHROME MONITOR

Clone 286 With
MEDIUM SPEED

\$1969

12MHz, 40MB HARD DRIVE,
EGA MONITOR

Clone 286 With
HIGH SPEED

\$2429



16MHz, 65MB HARD DRIVE,
VGA MONITOR

Standard Features of All Clone 286 Computers:

- 640K/1 MB RAM Standard (see chart).
- 1:1 Interleave, 2 Floppy/2 Hard Disk Controller (798 Kb/s RLL, 535 Kb/s MFM).
- 360K, 1.2M or 1.44M (3.5") Floppy Drive (your choice).
- 101 Key Enhanced Keyboard (Click-Tactile Option add \$20).
- 1 Parallel, 1 Serial, 1 Joystick Port.
- 200 Watt Power Supply.
- On-Board Clock/Calendar with Battery Backup.
- FCC Certified.
- System Reset Switch Located on the Front Panel.
- Setup in ROM.
- 80287 Math Coprocessor Socket.
- CPU Speed Switchable.
- Fully Expandable.
- Novell Compatible.
- One Year Parts and Labor Warranty.
- PC-Write - QModem - ExpressCalc Auto Menu - HomeBase - Money Master - Findex - Clone Utilities.

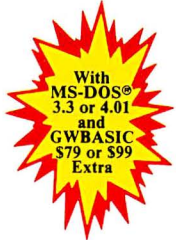

GUARANTEED
One year parts and labor. 30 day money back guarantee (except software).

SERVING YOU SINCE 1980



| CLONE VALUE CHART | | HERC MONO | VGA MONO | CGA COLOR | EGA COLOR | VGA COLOR |
|---|----------------|-----------|----------|-----------|-----------|-----------|
| 12MHz 640K RAM 1 WAIT STATE | 32MB RLL 65ms | \$1299 | \$1579 | \$1459 | \$1719 | \$1879 |
| | 42MB MFM 40ms | 1399 | 1679 | 1559 | 1819 | 1979 |
| | 65MB RLL 40ms | 1499 | 1779 | 1659 | 1919 | 2079 |
| | 122MB RLL 28ms | 1799 | 2079 | 1959 | 2219 | 2379 |
| 12MHz 1MB RAM 0 WAIT STATE | 32MB RLL 65ms | \$1449 | \$1729 | \$1609 | \$1869 | \$2029 |
| | 42MB MFM 40ms | 1549 | 1829 | 1709 | 1969 | 2129 |
| | 65MB RLL 40ms | 1649 | 1929 | 1809 | 2069 | 2229 |
| | 122MB RLL 28ms | 1949 | 2229 | 2109 | 2369 | 2529 |
| 16MHz 1MB RAM 0 WAIT STATE | 32MB RLL 65ms | \$1649 | \$1929 | \$1809 | \$2069 | \$2229 |
| | 42MB MFM 40ms | 1749 | 2029 | 1909 | 2169 | 2329 |
| | 65MB RLL 40ms | 1849 | 2129 | 2009 | 2269 | 2429 |
| | 122MB RLL 28ms | 2149 | 2429 | 2309 | 2569 | 2729 |

OPTIONAL EQUIPMENT FOR CLONE COMPUTERS

MODEMS & RODENTS

- Logimouse with software, Bus or Serial ... \$ 75
- Hi-REZ Logimouse with software, Bus ... 94
- Logimouse with First Publisher ... 108
- Hi-REZ Logimouse with First Publisher ... 108
- CADD and Paint Show Plus ... 177
- Microsoft Mouse w/stwr, Bus or Serial ... 108
- Microsoft Mouse with Windows 286 ... 149
- C+H Mach III Joystick ... 32
- C+H Flight Stick ... 50
- 1200 Baud internal modem with software ... 59
- 2400 Baud internal modem with software ... 99

ADD-ONS & ACCESSORIES

- Autoswitching Hercules graphics/colorgraphics video card w/printer port, smooth scroll ... \$ 49
- Generic EGA card, 640 x 350 resolution ... 159
- Generic VGA card, 640 x 480 resolution ... 259
- Math coprocessors. All types, speeds in stock.
- Printer switch box, 2-position, 25 or 36 pin ... 29
- Printer switch box, 4-position, 25 or 36 pin ... 39
- 25 pin cable, 10', Molded ends, MM or MF ... 16
- 36 pin cable, 10', Molded ends, MM or MF ... 20
- Vertical CPU stand. Add \$9 for wheels ... 24
- AST Rampage 2MB EEMS memory board for

- ATs. Comes with 512K RAM ... \$439
- Masterpiece Plus power director. Includes modem protection ... 119
- The Complete Fax 9600 ... 449
- The Complete Answering Machine card ... 227
- The Complete Hand Scanner (400 DPI) ... 162
- The Complete Half-page Scanner ... 195
- Logitech ScanMan (400 DPI) ... 219

PRINTERS

- Star NX-1000 144cps, NLO ... \$179
- Star NX-1000 Rainbow, as above/color ... 239
- Star NX-15 120/30 cps NLQ, wide ... 319
- Star ND-15 180/45 cps ... 389
- Star NR-10 240/60 cps NLO ... 349
- Star NR-15 as above with wide carriage ... 449
- Star NB-15 300/100 cps NLO ... 759
- Star NB24-10 216/72 cps LO ... 469
- Star NB24-15 as above with wide carriage ... 579
- Star NX-2400 170/57 cps LQ24, pin ... 359
- Panasonic KX-P1124, 80/192 cps, 24 pin ... 359
- Panasonic KX-P1191, 80 col/120 cps ... 269
- Panasonic KX-P1801, 80 col/144 cps ... 219
- Panasonic KX-P10921, 80 col/240 cps ... 329
- IBM parallel printer cable, molded ends ... 12

NO ORPHANED CUSTOMERS

We have been supplying customers with high quality hardware and software since 1980. Sound engineering, high performance, quality construction, outstanding warranties and a reputation for doing the right thing have been our way of doing business since Day One. As the manufacturer of Clone Computers, we stand behind each computer sold with a 100% commitment to our customer's satisfaction. Price, Performance, Value...Clone is the clear choice for serious computer users. Remember...YOUR BEST FRIEND MAY BE A CLONE.



Buy with Confidence! Our Guarantee Removes All the Risk from Your Buying Decision!

The Clone Guarantee is simple and straightforward. You have 30 days after receipt of your Clone to see if you and it are going to be compatible. If you are not satisfied with your Clone for any reason within that time, you may return it for a full refund, less shipping charges. Just don't write in the manuals and damage or lose anything that was in the original container, which also must be returned. You can void your warranty by failing to exercise normal care when hooking up or operating your Clone. Complete warranty details are available on request.



TURBO CLONE

AT Style Keyboard **\$749** Save Now!

Standard Features:

- 8088 @ 4.77 - 10MHz Turbo-speed Mainboard.
- 640K RAM standard.
- 8087 Socket.
- 150 Watt Power Supply.
- 360K Floppy Drive with Disk Controller.
- Hercules Compatible Video Card.
- HiResolution TTL Monitor (choose green or amber)
- 24 Parallel Printer Ports.
- I-Serial Port (2nd Optional at \$29).
- Game-Joystick Port.
- Clock Calendar with battery backup.
- 8 Slots.
- Fully Expandable.
- Mom's ROM BIOS.
- PC-Write - QModem - ExpressCalc - HomeBase - MoneyMaster - Findex - Clone Utilities - AutoMenu.

- FCC Class B Certified.
- Keyboard Lock.
- System Hardware Reset Switch on Front Panel.

- LED's for Power, Turbo and Hard Disk Access.
- One Year Parts and Labor Warranty.



**CLONE COMPUTERS • 2544 W. Commerce St. • Box 223957
Dallas, Texas 75222-3957 • Telex: 882761 • Fax: 214-634-8303**

For information or technical assistance call 214-637-5400

©1989 by Clone Computers. All rights reserved. Prices and specifications subject to change without notice. All prices are in U.S. Dollars. Payments must be in U.S. funds drawn on a U.S. bank.

Clone smolD

Reg. U.S. Pat. Off.

Circle 22 on Reader Service Card

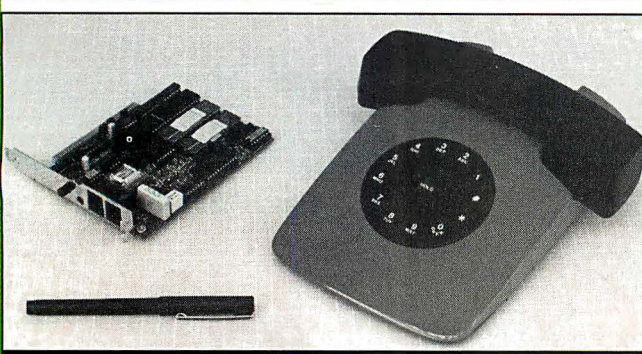

\$95 2400 BAUD MODEM

30 DAY FREE TRIAL !

Many low cost modems are faulty or very error prone. . . **Not ours!!! PERFORMANCE...** "I have recently had a lot of trouble getting 2400 BAUD MODEMS to work... this one is working perfectly." R.T. Moreno Valley CA. **SUPPORT...** "I get the impression that your company indeed, bends over backwards to provide service to its customer." M.F. Selma CA. **SUPERIOR TECHNOLOGY...**The phone connection is the main source of data errors. **DYNAMIC IMPEDANCE STABILIZATION, DIS** (invented by CompuCom) improves signal quality and reduces errors by up to 95% compared to a standard modem. Model 2400 (without DIS) at \$95 outperforms the low cost alternatives, the 24DIS at \$119 outperforms the challengers, regardless of cost. IBM internal, made in USA, 6 COM ports, internal speaker, five year warranty, software included, dealers inquire. *If you aren't totally satisfied, return within 30 days for a full refund!*

March '89p102
"Real deal. . .worked fine. . .quite a bargain." **BYTE MAGAZINE**
 CALL FOR DETAILS
CompuCom Corporation (800) 228-6648

PC COMPATIBLE ENGINEERING

Annabooks gives you the **hardware, software, and firmware** information you need to design PC-compatible systems faster and better. And you have control of your design from the ground up -- our firmware and software products include **source code!** Plus all the utilities you need. Do hardware design? **Doctor Design's 1M DRAM SuperSpec** is the first of a series of hardware books you won't want to miss. And a PC Bus timing book is on the way! Start by getting these books:

- AT BiosKit:** an AT Bios with source code you can modify. With setup & debug. 380 pages with disk, \$199
- XT BiosKit:** Includes a debug. 270 pages with disk, \$99
- Intel Wildcard Supplement for XT BiosKit:** Includes ASIC setup, turbo speeds, 60 pages with disk, \$49
- 1M DRAM SuperSpec:** Design your memory to all mfg's specs at once! Lots of timing diagrams & tables, \$79
- PromKit:** Puts anything in Eprom or SRAM; DOS, your code, data, you name it! With source on disk, \$179
- SysKit:** Here's a debug/monitor you can use even with a brand X Bios. Includes source, of course. \$69
- XT-AT Handbook:** The famous pocket-sized book jam-packed with hardware & software info. \$9.95 ea. or 5 or more for \$5 each.

Software tools: You need MS C & MASM 5.1 for modifying the Kit products.
FREE Mention this ad when you order and get a **free XT-AT Handbook by Cholsar & Foster!** Hurry before we come to our senses and change our minds.

Annabooks
 12145 Alta Carmel Ct Suite 250-262
 San Diego, California 92128 (619) 271-9526 Money-back guarantee



BYTE BACK ISSUES FOR SALE

1986 1987 1988 1989

| | | | | |
|--|--|--|--|--|
| January | | | | |
| February | | | | |
| March | | | | |
| April | | | | |
| May | | | | |
| June | | | | |
| July | | | | |
| August | | | | |
| September | | | | |
| October | | | | |
| November | | | | |
| December | | | | |
| Inside the IBM PCs Applications Software Today | | | | |

Issues Available

Rates (postage and handling included):

| | | | |
|--------------------------------|---------|-------------------------|--------|
| 1985 BYTE Issues | \$4.00 | BYTE 1987 Index | \$3.00 |
| 1986-'89 BYTE Issues | \$6.00* | 1985 Inside The IBM PCs | \$4.00 |
| BYTE '83-'84 Index | \$3.00 | 1986 Inside The IBM PCs | \$5.00 |
| BYTE 1985 Index | \$3.00 | 1988 Inside The IBM PCs | \$6.00 |
| BYTE 1986 Index | \$3.00 | Applications Software | |
| *June 1988 (Benchmarks) \$3.00 | | Today Special | \$4.00 |

The above prices include postage in the US. Please add \$.50 per copy for Canada and Mexico; and \$2.00 per copy for foreign countries (surface delivery). European customers please refer to Back Issue order form in International Advertising section of book.

Please indicate which issues you would like by checking (✓) the boxes. Send requests with payment to:

BYTE Back Issues, One Phoenix Mill Lane, Peterborough, NH 03458 (603) 924-9281

Check enclosed Charge: VISA MasterCard

Card # _____
 Exp. Date _____
 Signature _____
 Name _____
 Address _____
 City _____
 State _____ Zip _____

All orders must be prepaid. Please allow four weeks for domestic delivery and twelve weeks for foreign delivery by surface mail.

Compu\$ave



1-800-877-8855

International Orders are Welcome!

BOARDS

- Adv. Dig. Slave 535 Orchid Pro Design ... 295
- AST 5251-11E + 595 Paradise VGA+ 258
- ATVGA Wonder Save Paradise VGA + 16 ... 292
- BOCA RAM AT 139 Sigma VGA H 275
- Genoa 5300/5400 Call Sota 286 I Save
- Intel Above Board + 392 STB VGA EM 512K ... 358
- Konan Ten Time Save Video 7 V RAM 468
- Metheus 1104 1029 Video 7 Vega VGA ... 258
- AdapteK, Alloy, Artist, Hercules, Imagraph Call
- Number 9, Photon, Pixelworks, Quadram Call
- Talltree, Tops, Verticom, VMI, West. Digital Call

DISK DRIVES

- Archive 40Mb Tape .. 319 Seagate 30Mb Kit ... 275
- Micropolis 71 Mb 519 Seagate ST251-1 ... 398
- Miniscribe 3053 429 Storage Dimensio . Save
- Miniscribe 40 Mb 309 Teac FD55 72
- Miniscribe 676 Mb .. 2825 Teac 1.44 Mb 92
- Miniscribe 338 Mb . 1929 Toshiba 720K, 3.5" ... 79
- CDC, Emerald, Genoa, Iomega, Maxtor Call
- Panasonic, Plus, Priam, Sysgen, Tecmar Call

SOFTWARE

- Autosketch 2.0 64 Microsoft PC Works 95
- Bitstream Fonts 109 Microsoft Word 5.0 ... 212
- Carbon Copy Plus 107 PC Tools Deluxe 43
- Crosstalk 16 98 Peachtree Complete ... 157
- DBase IV Save Quattro 143
- Fastback Plus 104 Turbo C 97
- Harvard Graph 279 Ventura Publisher 489
- Lotus 123 295 XTree Pro 68
- Lotus Symphony 415 WordPerfect 5.0 225

COMPUTERS

- Acer Computers Save Toshiba T1200F 1359
- AST Premium 286 1299 Toshiba T1200FB ... 1495
- AST Premium 386C .. 2799 Toshiba T1200HB ... 2345
- AT&T Computers Save Toshiba T1600 3199
- Everex Computers Call Toshiba T3100E 2745
- Intel 25 Mhz Save Toshiba 3200 3465
- Mitsubishi 286/386 Save Toshiba 5100 4575
- Mitsubishi 20 Mb Lap .. 2298 Toshiba 5200 6199
- NEC Computers Save Wyse 2108 949
- PC/XT Turbo 535 Wyse 2112 1375
- Packard Bell Save Wyse 3216 2099
- Samsung 286/12Mhz 1199 Unisys286/386 Save
- Televideo 286/386 Save Zenith Supersport .. 1569
- Toshiba 1000 778 Zenith SS 286 3265

CHIPS

- Intel 80287 6/8/10 Mhz 142/204/238
- Intel 80387 16/20/25 Mhz 365/429/539

TERMINALS

- Altos IV 355 Televideo 955 379
- Altos V 485 Wyse 30 285
- IBM 3151 385 Wyse 50 355
- Kimtron KT-70 PC 359 Wyse 60 392
- Link MC-5 392 Wyse 85G 359
- Logitech 905 299 Wyse 150 365
- Adds, Ampex, HP, Sun River, & Other Models Call

MICE

- Logitec C7 Serial 62 Microsoft/paint 99
- Logitec New HiRes 86 Microsoft w/windows ... 132
- Logitec PS/2 62 Mouse Systems PC II 89

PLOTTERS

- Calcomp 1023GT 3779 HP 7595 A 6795
- Calcomp 1025E Save HP Draft DXL 3699
- Calcomp 1044GT ... 10,239 Iollne 3500 2375
- Enter SP1800 3295 Iollne 3700 2995
- Houston DMP 52 2295 Iollne 4000 3695
- Houston DMP 61 2995 JDL 850 GL 2799
- Houston DMP 62 3988 Roland 885 689
- HP 7475 A 1395 Roland 980 869
- HP 7550 A 2895 Roland DXY 1100 ... 889
- HP 7570A 2875 Roland GRX Save
- Bruning, Numonics, Mural, Versatec Call

DIGITIZERS

- Calcomp 12 x12 348 Houston Hi Pad + .. Save
- Calcomp 44 x 60 3895 Kurta IS 12 x 12 282
- Calcomp 36 x 48 3395 Kurta IS 12 x 17 482
- GTCO 24 x36 1895 Scriptel Save
- GTCO 36 x 48 2345 Seiko Save
- Hitachi 11 x 11 439 Summa 12 x 12 + ... 328
- Hitachi Puma Pros Save Summa 12 x 18 558

MODEMS

- ATI 2400 ETC, Int. ... 152 Practical 1200! 65
- Anchor 2400E 145 Practical 2400 PS/2 225
- Cardinal 2400 Int. ... 109 Prometheus 2400B/2 ... 129
- Hayes 1200 Ext. 275 Prometheus 2400G 149
- Hayes 2400 Ext. 415 Rascal-Vadic 2400VP ... 388
- Multitech 224 EC 305 USR HST 9600 59.9
- Multitech 224 EH 388 WorldPortPocket Save
- Multitech 9600 499 Zoom 2400 Ext. 125
- Practical 1200 Ext. 76 Zoom 2400 HC 119
- Avatec, Penril, Pack. Bell, Telebit, Ventel, UDS Call

PRINTERS

- Alps Allegro 24 339 Panasonic 1191 249
- Brother HL8E 2045 Panasonic 1124 Save
- Canon BJ 130 699 Panasonic Laser 1485
- Citizen MSP45 375 Okidata ML320 329
- Citizen 1800 162 Okidata ML 390 455
- Diconix D150 294 Okidata 393C 1069
- Genicom 3410 1499 QMS Kiss Plus 1665
- NEC LC 890 3189 QMS PS810 3999
- NEC P2200 335 Qume Crystal Print ... Save
- NEC P5200 499 Qume Script Ten 3199
- NEC P5300 665 Star NX-1000 172
- Panasonic 1180 189 Star NX-2400 318
- Fujitsu DL3400: 24pin, 132 col. 240cps 508
- Brother, C.Itoh, Data Products, Epson, HP Call
- OTC, Seikosha, TI, Varityper, Toshiba Call

MONITORS

- Amdek 1280 638 NEC Multisync 3D ... 665
- Amdek 732 399 NEC Multisync 2A ... 499
- Conrac/Relisys Save PGS Ultra 16 869
- Genius 402/420 Save Packard Bell TTL 75
- Samsung Multi 425 Sigma Laser 19" ... 1765
- Mitsubishi 1381A 475 Sony 1302 639
- Mitsubishi HL6605 . 1229 Taxan Save
- Monitern Save Hitachi 20" Multi 2095
- Nanao Flexscan 995 Zenith 1490 578
- Seiko CM 1430 : 14" Multisynch 1024x768 595

SCANNERS

- DFI Handy Scanner ... 219 PC Hand Scanner ... 152
- PGS LS-300 w/paint . 725 Logitec Scan Man ... 215
- AST, Datacopy, Dest, HP, Panasonic, Taxan Call

Mail Address: Compu\$ave - 4207 S. 37th Street - Dept B5 - Phoenix, AZ 85040. Order lines open: Mon- Fri. 7 am - 6 pm. Sat.: 9 am - 2 pm. Prices reflect cash discounts and are subject to change without notice. We do not guarantee compatibility. DOA's are repaired or replaced, please call for a RMA. Major credit cards and selected PO's are accepted.

INTERNATIONAL SALES (602)437-4855 - FAX (602)437-9685 - CUSTOMER SERVICE (602)437-4856

COMPARE OUR NEW LOWER PRICES AND SUPERIOR QUALITY

PCI-286-12

- 80286-12
- 1.2 MB Floppy Drive
- 640K RAM
- Serial / Parallel / Game
- 101-Key Enhanced Key Board
- SI = 13.3 (1 Wait)
- SI = 15.2 (0 Wait \$100 Option)
- 6/12 MHz Key Board Switchable
- WA2 HD & FD Controller
- 80287 SOCKET
- 200W POWER SUPPLY



PCI-386-20

- 80386-20
- W/40 MB HD

Mono System **\$2295**
EGA **\$2695**
VGA **\$2995**

MONO SYSTEM

- W/Mono Monitor
- 20 MB Hard Disk

\$1195

VGA COLOR SYSTEM

- W/WGA Card & Monitor
- 20 MB Hard Disk

\$1795

EGA COLOR SYSTEM

- W/EGA Card + Monitor
- 20 MB Hard Disk

\$1580

GAS PLASMA 286-12 ___ **\$2295**

- 80286-12 CPU
- SI = 13.3
- 3 1/2" FD 1.44 MB
- 20 MB HD ST-138
- LCD Screen (640 X 400)
- I/O Card Parallel/Serrial/Game
- 640K RAM

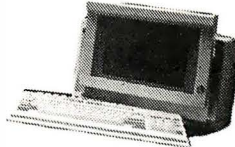

GAS PLASMA 286-20 ___ **\$2495**

- CPU 80286-20
- SI = 23

LCD-286-10 PORTABLE ___ **\$1595.00**

- 10 MHZ 80286 SI=10.3
- 12 MHZ SI = 13.3 (Option \$50.00)
- 16 MHZ SI = 18 (Option \$250.00)
- 640K RAM
- LCD Screen 640 X 200 (Option 640 X 400 \$180.00)
- Super Twist & Back Lighting
- 86 Key Board
- External / Parallel / Game
- 1.2 MB Floppy drive
- 20 MB Hard Disk
- 80287 Socket
- 200 W Power Supply
- Side 15 3/4" X 9 1/2" X 8"
- 23 LBS



LCD-386-16 ___ **\$2595.00**

- 80386-16 MHZ
- 40 MB Hard Disk
- 80387 Socket

LCD-386-20 ___ **\$2695.00**

- 80386-20 MHZ
- 40 MB Hard Disk
- 80387 Socket

CRT-PORTABLE-286 ___ **\$1389**

- Compaq Type
- 80286 (10 MHZ or 12 MHZ)
- 12 MHZ SI = 13.3 (Option \$50.)
- 16 MHZ SI = 18 (Option \$250)
- One 1.2 MB Floppy Drive
- 200 W Power Supply
- TTL Disply 9" Amber
- AT Key Board
- Serial / Parallel / Game
- WA2 HD & FD Controller
- 20 MB Hard Disk



CRT-386-16 **\$2395**

- 80386-16

CRT-386-20 **\$2495**



PCI PACIFIC COMPUTER

702 S. Del Mar Ave., #B,
San Gabriel, California 91776
(FAX) 818-286-8662

(818) 571-5548 (Technical support)
(800) 421-1102 (IN CA) ORDER ONLY
(800) 346-7207 (OUT CA)

*ALL SYSTEMS COME WITH ONE YEAR PARTS & LABOR WARRANTY

Mon - Sat
9:00 AM - 6:00 PM

Advertise your computer products through **BYTE BITS** (2" x 3" ads)

For more information call Mark Stone at **603-924-6830**

BYTE

One Phoenix Mill Lane
Peterborough, NH 03458

Circle 310 on Reader Service Card

SERIAL/PARALLEL Communications Board

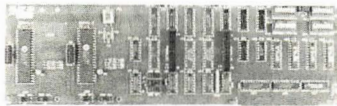

- Two Parallel Printer Ports
 - Two 8-Bit Digital I/O Ports
 - Two Serial Ports, RS-232, RS-422 or RS-485
 - Address Selectable
 - Selectable & Shareable Interrupts
- 1-800-553-1170**



478 E. Exchange St., Akron, OH 44304
TEL: (216) 434-3154 FAX: (216) 434-1409
TLX: 5101012726

Circle 226 on Reader Service Card

NEW

PARALLEL PORT FOR PS/2



- MODELS 50, 60, 80**
- LPT1, LPT2, LPT3
 - Optional Serial Port
 - OEM Pricing Available
- 1-800-553-1170**



478 E. Exchange St., Akron, OH 44304
TEL: (216) 434-3154 FAX: (216) 434-1409
TLX: 5101012726

Circle 227 on Reader Service Card

EPROM PROGRAMMER

FOR THE PC \$129.95

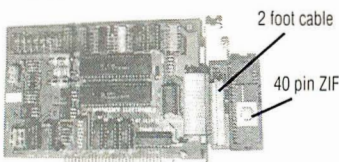

- 2716 to 1 Meg, updateable to 32 Meg
- Programs 2764A in 10 seconds
- Menu driven software
- No personality modules required
- Adapter for 8748, 49, 51, 52, 55, TMS 7742 \$50
- 1 year warranty
- 10 day money back guarantee
- Available for Apple II \$92.50
- For more information, call (916) 924-8037



NEEDHAM'S ELECTRONICS

4535 Orange Grove Ave. • Sacramento, CA 95841
(Monday - Friday 8:00 am - 5:00 pm PST)

Circle 188 on Reader Service Card

RS-422 FOR PS/2



MODELS 50, 60, 80

- Two Channel
- Transfers to 256 K baud
- Address Selectable
- Interrupt Selectable

1-800-553-1170



478 E. Exchange St., Akron, OH 44304
TEL: (216) 434-3154 FAX: (216) 434-1409
TLX: 5101012726

Circle 228 on Reader Service Card

INTERFACE CARDS for PC/AT and PS/2



COMMUNICATION DATA ACQUISITION & CONTROL

FOR A FREE CATALOG CALL

1-800-553-1170



478 E. Exchange St., Akron, OH 44304
TEL: (216) 434-3154 FAX: (216) 434-1409
TLX: 5101012726

Circle 229 on Reader Service Card

Conversion -

Our programs read (R), write (W), format (F) diskettes of these systems directly in your PC:

HP 9000 series 300, 200,
HP 64000 (RWF: \$ 580),
DEC RT11 (RW: \$ 500),
RSX-11M, VMS (RW: \$ 640),
Wang OIS, TA Bitsy,
Olivetti ET, ETS, ETV (R: \$ 400)

Convert into ASCII or DCA/RFT with format controls. Inquire for other systems and CAD conversions.

Euro/Mastercard/VISA or prepaid. Free airmail shipping worldwide!

punctum GmbH, Ringseisstrasse 10a,
D-8000 München 2, West-Germany
Fax: Intl. 49 89 53 28 321 or
call Intl. 49 89 53 27 42
from 9 to 17 h German Time

Circle 217 on Reader Service Card

UNIVERSAL PROGRAMMER



- For E(E)PROM, PAL, BIPOLAR 8748/51Series PROGRAMMING & IC/Memory TESTING
 - High-Speed, Parallel Interface
- ONLY \$545 COMPLETE**
Also Individual/Gang Units

XELTEK

473 Sapena Ct. Unit 24
Santa Clara, CA 95054

1-800-541-1975 (Toll Free Order)
Tel: (408) 727-6995, Fax: (408) 727-6996
COD, VISA, MC, AM EX Accepted

Circle 293 on Reader Service Card

MARYMAC®



Radio Shack® SCO Tandy®

We will meet or beat... GUARANTEED LOWEST PRICES

MARYMAC INDUSTRIES INC.
22511 Katy Fwy.

Katy (Houston), TX 77450
1-713-392-0747 FAX (713) 574-4567

Toll Free 800-231-3680

Circle 164 on Reader Service Card

California Digital

17700 Figueroa Street • Carson, California 90248



Color Monitor Better Than EGA \$219

Ideal for CAD/CAM and Desk Top publishing applications. The Roland CD/240 color monitor has a resolution of 720 pixels by 400/480 lines on a 31mm dot pitch 12" non-glare screen. VGA specifications in text mode EGA in graphic mode.

California Digital has made a special purchase and is able to offer the CD/240 EGA/VGA RGB color monitor for only \$219.

Full featured, 132 column, multi-resolution video color adapter card available for only \$159 additional. Comparable card package would retail for \$1095.

20" Analog Color \$1895 \$659



Ever try gathering a classroom of students around a 12 inch monitor? This 20 inch analog RGB monitor is the ideal solution. High screen resolution of 1200 pixels by 950 lines allow extra fine detail without the dots looking like golf balls. 256 colors and VGA compatible. Super value originally sold for over \$2000. Only 350 available.

Wizard ~~\$299~~ \$239



The hit of the Consumer Electronics Show...The Wizard is your personal electronic secretary that replaces your telephone directory, scheduling calendar, World clock, alarm, memo pad and calculator.

Available soon, an interface that allows you to transfer files between the Wizard and your personal computer. You have seen the Wizard selling for \$295 at the Sharper Image and other electronic boutiques. California Digital everyday discount price only \$239.

Options available: Time/Expense Management; Dictionary/Thesaurus

Amstrad

~~\$1379~~

- Two 720K/byte 3 1/2" drives
- 640 K/byte DRAM memory
- 2400 baud internal modem
- Supertwist LCD display
- 16 color RGB/CGA output
- Full feature 101 keyboard

\$695

Take it to school, court, news events or anywhere that you require "computing power" on the go. Built in 2400 bps home compatible modem allows you to transfer data files with your home office or any World wide data base.

A little too large to be called a laptop but the Amstrad 640 is a true battery operated IBM compatible portable. (17 3/4 by 9" footprint). Includes: full featured AT style 101 keyboard • 2400 bps modem • DOS 3.3 • serial port • printer port • carrying case • power adapter and cigarette lighter power cord.

40 Meg. Tape Back-up \$239



Head Crash, Power Spikes or just poor disk maintenance... Don't loose data because you didn't back up. The Alloy/40 is an inexpensive way to save and restore files in the event that your data has been destroyed.

This 40 megabyte half height tape back is manufactured by North America's largest producer of data retrieval equipment.

No need to purchase a separate tape controller... The Alloy/40 attaches directly to your existing floppy disk controller. Supplied software allows your computer to back up any time Day or Night. Come back in the morning and 40 megabytes of irreplaceable data has been stored on one Scotch DC/2000 data cassette.

Back up entire hard disk, modified files only, or by file name. Loss of data is inevitable but when you are backed up on an Alloy/40 its not a catastrophe.

Build Your Own Computer \$35 AT Case Only



California Digital has all the components needed to customize your own computer. Buy as much computing power as you need now, and up grade when the need arises. Here are some examples of components available:

| | | | |
|------------------------------------|------------|---------------------------------------|------------|
| 8 slot 10 MHz Mother board |\$89 | Monochrome card, printer port |\$25 |
| 8 slot 12 MHz baby AT Motherboard |\$229 | MonoGraphics (Hercules) printer port |\$45 |
| Full size five drive AT case |\$5 | Color graphics card |\$49 |
| Four drive XT case |\$25 | EGA Color Multi Resolution II |\$159 |
| 101/102 AT/XT German mfg. Keyboard |\$7 | I/O card, serial & parallel |\$35 |
| 200 watt AT power supply |\$9 | 1/0 PLUS, Ser/Par I, clock, game |\$9 |
| Teac 350K/Byte disk drive |\$9 | Disk I/O, disk control, clock, game |\$9 |

Scanner \$1299 \$359



The Saba Scanner inputs a printed page in less than three seconds. OCR software allows your computer to transfer printed pages into ASCII files or directly to spreadsheets and word processing programs.

Archival data, legal briefs... No problem. Simply insert the page into the Saba and in seconds the document is digested into your computer and ready for editing. Limited quantities available. Original price \$1299; now only \$359.

NEC/890 Laser Printer \$3095



PC Magazine has chosen the NEC-890 best laser printer of the year. (Jan. 12, 1988). And its obvious why... the printer is Postscript, Hewlett Packard, and Apple compatible, and comes standard with three megabytes of memory. The 890 accepts data from parallel, serial and Apple-Talk devices.

NEC has also incorporated 40 built-in fonts along with two paper trays into this industrial quality laser printer.

- Other Laser Printers Available
- | | |
|---|-------------|
| Hewlett Packard Laser II, 8 pages per minute |\$1659 |
| QMS PS/810 2 Meg., 35 fonts, Postscript 8 pgs | 3879 |
| Apple Laser Writer II SE | 1979 |
| Texas Instruments 2115 Postscript 15 pgs. | 5426 |
| NEC 890/XL (new for Fall 1989) | call |

One Two Ten

| | | | |
|----------------------------------|-----|-----|-----|
| TEC501 1/2 height sgl.side | 49 | 39 | 35 |
| FANDON 101/4 full ht. 96 TPI. | 99 | 89 | 79 |
| FUJITSU 5 1/4" half height | 65 | 63 | 57 |
| MITSUBISHI new 501 half ht. | 119 | 109 | 105 |
| MITSUBISHI 504A AT comp. | 149 | 139 | 135 |
| TEAC FD55BV half height | 89 | 85 | 79 |
| TEAC FD55FV 96 TPI, half ht. | 119 | 109 | 105 |
| TEAC FD55GF for IBM AT | 109 | 105 | 99 |
| PANASONIC 455 Half Height | 109 | 99 | 89 |
| PANASONIC 475 1.2 Meg./96 | 119 | 115 | 109 |
| Switching power supply | | 49 | |
| Dual enclosure for 5 1/4" drives | | 59 | |

3 1/2" DISK DRIVES

| | | | |
|------------------------|-----|-----|------|
| SONY MP-53W 720K/Byte | 129 | 125 | 119 |
| SONY MP-73W, 2 Meg. | 159 | 149 | call |
| TEAC 35FN 720 K/Byte | 129 | 119 | 115 |
| TEAC 35HN/30, 2 Meg. | 159 | 149 | 145 |
| 5 1/4" form factor kit | | | 20 |

8" DISK DRIVES

| | | | |
|--------------------------|-----|-----|-----|
| QUME 842 double sided | 189 | 179 | 175 |
| QUME 841 single sided | 119 | 109 | 99 |
| SHUGART 851R dbl. sided | 319 | 309 | 299 |
| REMEX RFD4000 dbl. sided | 189 | 179 | 165 |
| OLIVETTI 851 | 189 | 179 | 165 |

Hitachi 11 by 17 Plotter ~~\$895~~ \$595

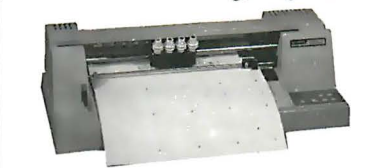

The Hitachi 672/XD is a four color 11 by 17 (B size) plotter with superior accuracy and repeatability (.3mm). The 672 accepts HP/PLG 7475 commands and is both Centronics parallel and RS232C compatible.

The 672 plots at a fast eight inches per second in axial direction and eleven inches at an angle of 45 degrees. The plotter also features a self contained digitizing function that allows data to be entered into your computer from printed graphs and blue prints.

Four different color pens are supplied with the plotter but a wide variety of technical pens are available.

PROFIT from the IBM PC 99¢

We have just purchased 6000 copies of Dan Post's "Profit from the IBM PC". This is a 184 page hard bound publication that retails for \$17.95.

Mr. post explains how to apply your data processing skills to capitalize in the growing personal computer industry.

40 Megabyte Hard Disk Kit \$397

Forty megabyte internal hard disk drive, controller and cables all for only \$397.

The kit includes the a 40 milisecond Miniscribe 3650 drive and a half slot Western Digital controller.



Five Inch Winchester Disk Drives

| | | |
|------------------------------------|------|------|
| Price does not include controller. | each | two+ |
| SEAGATE 225 20 Meg. 1/2 Ht. | 239 | 229 |
| SEAGATE 238 30 Meg. RLL | 259 | 249 |
| SEAGATE 251/1 51 M. 28ms. | 459 | 445 |
| SEAGATE 4096 96 M. 35ms. | 559 | 539 |
| MINISCRIBE 8425 25 M 65ms.239 | 229 | |
| MINISCRIBE 3650 50M 61 ms. | 319 | 309 |
| MINISCRIBE 6085 90 meg. | 459 | 435 |
| MINISCRIBE 3053 25 ms. 1/2 ht. | 359 | 339 |
| FUJITSU 2242 55 M. 35ms. | 1299 | 1229 |
| FUJITSU 2243 86 M. 35ms. | 1695 | 1619 |
| RODIME RO-204E 53 Meg. | 895 | 859 |
| MAXTOR XT1140 140 Meg. | 1495 | 1450 |
| MAXTOR XT2190 192 Meg. | 1919 | 1875 |
| TOSHIBA MK56 70 M. 30ms. | 1289 | 1229 |
| CONTROL DATA WREN "U" | call | |

Winchester Controllers for IBM/PC

| | |
|--------------------------------------|-----|
| XEBEC 1220 with floppy controller | 159 |
| DTC 5150CX | 119 |
| OMTI 5527 RLL controller | 99 |
| ADAPTEC 2070 RLL controller | 99 |
| ADAPTEC 2372A 1/1 interleaf | 159 |
| WESTERN DIGITAL WD/1002WX2 | 89 |
| WESTERN DIGITAL 1003WAH or WA2 | 139 |
| WESTERN DIGITAL 1007/WA2 ESDI | 239 |
| • SCSI/SASI Winchester Controllers • | |
| XEBEC 1410A 5 1/4" foot print | 239 |
| WESTERN DIGITAL 1002-05E5 1/4" | 229 |
| OMTI 20L | 89 |
| • Winchester Accessories • | |
| Dual floppy enc. and powersupply | 59 |
| Winchester enclosure and supply | 139 |
| Switching power supply | 49 |



master charge
VISA

8:00 AM to 5:00 PM
Pacific Time

Every year since 1973, customers from virtually every nation in the free World have chosen California Digital for their data processing requirements. If its computer, California Digital has it... complete minisystem or just one microchip. California Digital offers over 10,000 unique computer products. Regardless of how specialized your data processing requirements... California Digital is your one stop shopping solution.

TECHNICAL & CALIFORNIA
(213) 217-0500
TOLL FREE ORDER LINE
(800) 421-5041

Telefax • (213) 217-1951

IEEE 488 Solutions

- Hardware & software interfaces for PC, AT, 386, PS/2, Macintosh, SUN, HP & DEC
- IEEE converters to SCSI, RS-232, RS-422, modem, Centronics, digital I/O & analog I/O
- IEEE extenders, expanders & buffers
- IEEE drivers for DOS, UNIX®, Lotus 1-2-3, Symphony & Quattro.

Call or send for your
FREE Technical Guide
Demo disks and application notes available

Please see our ad on page 249.

LOtech

(216) 439-4091

Telex 6502820864 • Fax (216) 439-4093
LOtech, Inc. • 25971 Cannon Road
Cleveland, Ohio 44146

Circle 138 on Reader Service Card

16-BIT RESOLUTION ANALOG-TO-DIGITAL CONVERTER 12,000 SAMPLES/SEC for IBM PC, XT & AT SINGLE PIECE PRICE \$475

We manufacture a broad line of data acquisition and control hardware and software for Apple and IBM computers.

Call for quotes on custom hardware or complete systems.

LAWSON LABS, INC.

5700 RAIBE ROAD
COLUMBIA FALLS, MT 59912
800-321-5355 or 406-387-5355



Circle 152 on Reader Service Card

UNIVERSAL/GANG PROGRAMMER

made in U.S.A.

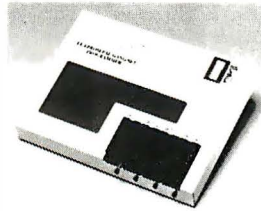

\$595.00
Includes
One Year
Update
and
Warranty

HUSKY™ programs EE/EPROMS, CMOS PLDS, and Micros. It's your best bet when low cost and quality are both important.
From the people who make CUPL and ALLPRO.

LOGICAL DEVICES, INC.

1201 N.W. 65th Place
Ft. Lauderdale, FL 33309
305-974-0967
1-800-331-7766

Circle 154 on Reader Service Card
(DEALERS: 155)

PAL™ /PLD SOFTWARE Sets The Standard

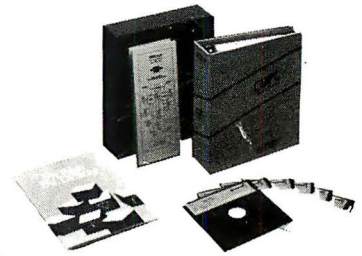

CUPL™ PLD compiler, the most powerful language for state machine logic design, now allows OrCAD™ schematic software as the front end design entry. CUPL supports all PLDs and carries the most extensive update program. Available on MS-DOS™, Apollo™, Sun™, VAX™ and most UNIX™ based platforms.

LOGICAL DEVICES, INC.

1201 N.W. 65th Place
Ft. Lauderdale, FL 33309
305-974-0967
1-800-331-7766

Circle 156 on Reader Service Card
(DEALERS: 157)

NEW DOSTAR™ NEW

TAR FOR MSDOS WITH UNIX/XENIX COMPATIBILITY

Read, write 16 different Unix formats including
Altos, AT&T, IBM, NCR, Tandy & others

Multiple disk types — 3 1/2", 5 1/4" and 8"

Fully compatible with Unix tar
— backup under MSDOS, restore onto Unix
— backup Unix files, restore onto MSDOS

Menu-driven, using windows,
function keys, on-line help

Only \$295.00

Bringing Unix & DOS together

New Generation Systems, Inc.
3609-B Chain Bridge Rd., Fairfax, VA 22030
Tel: (703) 691-0779 Fax: (703) 691-0397

In Canada please call:

New Generation Systems (Canada)
1110 Kamato Rd., Units 18-19, Mississauga, Ont. L4W 2P3
Tel: (416) 238-1047 Fax: (416) 238-1039

Altos, AT&T, DOSTAR, IBM, MSDOS, NCR, Tandy, Unix, Xenix, are trademarks of their respective companies.

Circle 304 on Reader Service Card

! not only a printer buffer !

THIS IS THE MOST SOPHISTICATED
PRINTER BUFFER - MULTIPLEXOR - SWITCH

WITH TWO SEPARATE INPUTS (SERIAL AND PARALLEL) AND TWO SEPARATE OUTPUTS (SERIAL AND PARALLEL) CAN BE USED LIKE STANDARD BUFFER. WITH ANY INPUT TO ANY OUTPUT - BUT ALSO YOU CAN CONNECT 2 COMPUTERS TO 1 PRINTER, OR 1 COMPUTER TO 2 PRINTERS, OR 2 COMPUTERS AND 2 PRINTERS. AND MORE - 1 COMPUTER TO 3 PRINTERS OR 3 COMPUTERS TO 1 PRINTER.
HIGH CAPACITY - 64 KB TO 256 KB AND - 256 KB TO 1 MB (MODELS A AND B) PAUSE, COPY AND RESET FUNCTIONS SERIAL PORTS WITH 7 OR 8 BITS WORD LENGTH, 1 OR 2 STOP BIT, PARITY, XON/XOFF, DTR, RTS

DCB-A-64K \$ 195

DCB-B-256K \$ 255 (**)

(**) Power supply and parallel cables are included

ALSO, WE HAVE THE MOST COMPLETE DATA CONVERTER UNIT CONVERTS RS232 SERIAL TO CENTRONICS PARALLEL OR VICE VERSA, JUST BY MOVING JUMPERS BAUD RATE AND PROTOCOL FULLY PROGRAMMABLE FROM 180 TO 19200 BAUDS INCLUDES: DTR, RTS, XON/XOFF, PARITY, etc

DCU \$ 80 (**)

(**) Power supply and cables NOT included



serial<>parallel
bi-directional converter



INTECTRA Inc. - Dept. 232

2029 TERMINAL BLVD

MOUNTAIN VIEW-CA-94043

(415) 967-8818 TX 345545

SAME DAY SHIPMENT

D - RAMS

| | |
|--------------------|---------|
| 41256 - 06 | \$10.80 |
| 41256 - 08 | \$10.00 |
| 41256 - 10 | \$9.30 |
| 41256 - 12 | \$8.60 |
| 41256 - 15 | \$8.10 |
| 1mg x 1 - 10 | \$19.00 |
| 1mg x 1 - 08 | \$26.50 |

MATH CO-PROCESSOR

| | |
|------------------|----------|
| 8087 | \$96.00 |
| 8087 - 01 | \$170.00 |
| 8087 - 02 | \$120.00 |
| 80287 - 06 | \$140.00 |
| 80287 - 08 | \$200.00 |
| 80287 - 10 | \$220.00 |
| 80387 - 16 | \$325.00 |
| 80387 - 20 | \$400.00 |
| 80387 - 25 | \$500.00 |

CALL FOR LOWEST PRICES
1-800-2-SABINA

SABINA INTERNATIONAL, INC.

657 Brea Canyon Road Suite #4
Walnut, California 91789
(714)594-6336 • FAX (714)595-4008
PRICES SUBJECT TO CHANGE WITHOUT NOTICE

Circle 238 on Reader Service Card

TISAR-PC

(Pronounced TY-ZAR)

Keep records the way big business does...
(Hard drive required)

FULLY INTEGRATED
Remarkable Turn-Key System

- Data-base
- Invoicing
- Inventory control
- 3,000 records per file
- 12,000 invoices per file
- Accounts received
- Accounts receivable
- Customer statements
- Mailing labels

LIMITED OFFER
\$79.00

Now with point of entry pricing and user definable fields.
Search, cross-search, fast sorts, reports and much more.
Much easier than Dac-Easy, Peachtree, etc.

IDEAL for service or sales/mktg businesses.
Easy, menu-driven, user friendly, fully tested.
Up and running in under 3 minutes. Free customer support... Easy documentation.

CALL 1-800-537-LABS or ask your dealer.

COD gladly accepted
10610 Evans Street
Philadelphia, PA 19116
Dealer inquiries invited

Circle 72 on Reader Service Card

Satellite Communication

MICROSAT II

Expansion Board

\$700

IMMEDIATE DELIVERY

- For IBM PC/XT/AT and compatible.
- Satellite data receiver - 9600 baud.
- Satellite bulletin board.
- Satellite video and audio option - Add \$200

PERSONAL SPACE COMMUNICATIONS

707 Johnson Road, Blaine WA 98230
(604)597-6298 TLX 04-508306 FAX (604)597-6214

Circle 191 on Reader Service Card

This could be the most productive phone number you call today. Toll free. 1 (800) 531-5369

(Or, if you prefer to FAX your order—1 (512) 344-2985.)

TrippLite® Battery Back-Ups

\$1299.00

Protect your equipment and data by providing safe shut down time for your computer systems and other sensitive equipment during black or brown-outs. Data loss from one black-out can cost you hundreds, if not thousands of dollars. These units feature AC line spike and noise suppressors, status indicator lights and heavy gel-cell batteries—a regulated battery charger automatically restores battery to full charge when AC power returns.

\$239.00 **\$299.00** **\$599.00** **\$799.00** **\$399.00**

BC-200 200-W BC-325 325-W BC-750 750-W SC-BC-2000 2000-W BC-1200 1200-W BC-450 450-W

This complete TrippLite® Series offers reliable battery back-up at an extremely low price.

TrippLite® Voltage Regulator—Line Conditioners

\$79.00 \$149.00 \$199.00



LS-600 LC-1200 LC-1800

TrippLite® Line Stabilizer/Conditioners automatically adjust varying input voltage to provide full voltage support during a low voltage condition while suppressing spikes and line noise.

OMNI Power Director



CC16-P **\$79.95**
TrippLites' ISOBAR command console provides the highest level of surge and noise suppression of any console unit on the market today. Features include 6 outlets, 5 lighted power switches, protection indicator light, 15 amp circuit breaker and 12-foot power cord.

Eprom Programmer



EW-904 **\$179.95**
You can program your own EPROMS with this EPROM programmer—it can program up to 4, 16K thru 512K EPROMS simultaneously—easy to use software is included.

Eprom Eraser

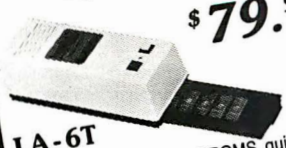

LA-6T **\$79.95**
You can erase your EPROMS quickly and easily at home or workplace with this easy to use EPROM eraser with built-in timer. It features an adjustable exposure time with alarm and is static protected. Without timer (not shown). LA-6A **\$59.95**

Cable Assemblies

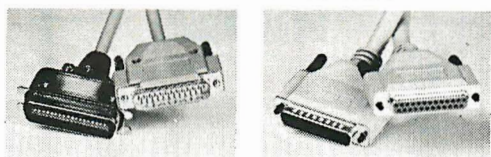

PC/AT Parallel Printer Cables

| Stock # | Length | Price |
|------------|--------|---------|
| PPC301-6 | 6 ft. | \$ 6.95 |
| PPC301-10 | 10 ft. | 7.95 |
| PPC301-15 | 15 ft. | 11.95 |
| PPC301-25 | 25 ft. | 17.95 |
| PPC301-6RA | 6 ft. | 12.95 |

DB-25 - 25 Line Cables Male-Male

| Stock # | Length | Price |
|----------|---------|---------|
| 25MM-6 | 6 ft. | \$ 6.95 |
| 25MM-10 | 10 ft. | 7.95 |
| 25MM-25 | 25 ft. | 17.95 |
| 25MM-50 | 50 ft. | 33.95 |
| 25MM-100 | 100 ft. | 62.95 |

POPULAR CABLES

| Stock# | Description | Price |
|---------|----------------|--------|
| MEC-6 | Monitor Ext. | \$5.95 |
| KEC-6 | Keyboard Ext. | 3.95 |
| ACPC-03 | Power Adapter | 4.95 |
| ATM-6 | AT Modem Cable | 5.95 |

call Other cables available

DB-25 - 25 Line Cables Male-Female

| Stock # | Length | Price |
|----------|---------|---------|
| 25MF-6 | 6 ft. | \$ 6.95 |
| 25MF-10 | 10 ft. | 7.95 |
| 25MF-25 | 25 ft. | 17.95 |
| 25MF-50 | 50 ft. | 33.95 |
| 25MF-100 | 100 ft. | 62.95 |

Hard Drive Cases



SDH-2H **\$99.00**

This sturdy metal cabinet is capable of handling up to two 1/2 height hard disk drives—comes complete with fan, switching power supply and mounting hardware. (Drive cables not included) 14 7/8" W X 13 7/8" D X 2 5/8" H.

Switchboxes



These sturdy metal switchboxes allow you to share computers, printers and other peripherals quickly and easily. They have gold-plated contacts and are EMI-RFI protected.

DB-25 25 Line Switchboxes

| Stock # | Description | Price |
|---------|----------------|---------|
| AB25-2 | Two position | \$19.95 |
| AB25-3 | Three position | 25.95 |
| AB25-4 | Four position | 28.95 |
| AB25-5 | Five position | 38.95 |
| AB25-6 | Six position | 59.95 |
| AB25-X | Cross over | 29.95 |

Centronics 36 Line Switchboxes

| Stock # | Description | Price |
|---------|----------------|---------|
| AB36-2 | Two position | \$23.95 |
| AB36-3 | Three position | 29.95 |
| AB36-4 | Four position | 34.95 |
| AB36-5 | Five position | 44.95 |
| AB36-X | Cross over | 37.95 |

We carry a complete line of switchboxes for your different requirements. Call for more information!

Alex Electronics, Inc.

"Your Electronics Supply House"

TERMS: Minimum order \$10.00. We accept Mastercard, Visa, and American Express at no additional charge. For C.O.D. orders, add \$2.20. For orders under \$100.00, add \$3.00 handling and actual UPS shipping charges. For orders over \$100.00, we pay handling charge—you pay actual UPS shipping charges plus insurance. Purchase orders accepted from approved accounts. All returns require an RMA# and are subject to a restocking fee. Texas residents add 7.5% sales tax. Prices subject to change and we are not responsible for typographical errors.

Store Hours: 8:00-6:00 M-F, 10:00-2:00 SAT CST
10731 Guldface, San Antonio, Texas 78216

VOICE MASTER KEY[®] VOICE RECOGNITION SYSTEM FOR PC/COMPATIBLES & TANDY 1000 SERIES A FULL FEATURED VOICE I/O SYSTEM

GIVE A NEW DIMENSION TO PERSONAL COMPUTING. . . The amazing **Voice Master Key System** adds voice recognition to just about any program or application. Voice command up to 256 keyboard macros from within CAD, desktop publishing, word processing, spread sheet, or game programs. Fully TSR and occupies less than 64K. Instant response time and high recognition accuracy. Voice recognition tool-box utilities are included. **A genuine productivity enhancer!**

SPEECH RECORDING SOFTWARE . . . Digitally record your own speech, sound, or music to put into your own software programs. Software provides sampling rate variations, graphics-based editing, and data compression utilities. Create software sound files you can add to macros for voice recognition verification response. **A complete, superior speech and sound development tool.**

SOFTWARE CONVERSION CODES . . . The **Voice Master Key System** operates a growing list of third party talking software titles using synthesized phonetics (text-to-speech) or digitized PCM, ADPCM, and CVSDM encoded sound files. **Voice Master Key System does it all!**

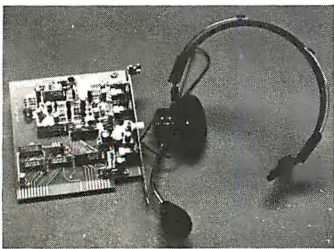

EVERYTHING INCLUDED . . . **Voice Master Key System** consists of a plug-in card, durable lightweight microphone headset, software, and manual. Card fits any available slot. External ports consist of mic inputs and volume controlled output sockets. **High quality throughout, easy and fun to use.**

ONLY \$149.95 COMPLETE

ONLY \$89.95 FOR TANDY 1000 SL/TL MODELS—
SOFTWARE PACKAGE ONLY.

Requires Tandy Brand Electret microphone.

ORDER HOTLINE: (503) 342-1271

Monday-Friday, 8AM to 5PM Pacific Time

Visa/MasterCard, company checks, money orders, CODs (with prior approval) accepted. Personal checks subject to 3 week shipping delay. Specify computer type and disk format (3½" or 5¼") when ordering. Add \$5 shipping charge for delivery in USA and Canada. Foreign inquiries contact Covox for C & F quotes. **30DAY MONEY BACK GUARANTEE IF NOT COMPLETELY SATISFIED. ONE YEAR WARRANTY ON HARDWARE.**

CALL OR WRITE FOR **FREE PRODUCT CATALOG**



COVOX INC. 675-D Conger St.
Eugene, Oregon 97402 U.S.A.
TEL: 503-342-1271 • FAX: 503-342-1283

SIBEC II

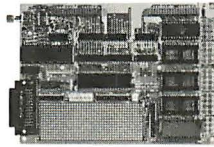

The ideal solution for embedded control applications and stand alone development.

- 8052 Basic CPU
- PROM Programmer
- iSBX[™] Expansion Bus
- Highest Quality
- 1 Year Warranty

\$228.00 QTY 1

Call Now! (603) 469-3232

Inquire about our 8051 product development kit for the IBM PC/XT/AT.



Binary Technology, Inc.

Main St., P.O. Box 67 Meriden, NH 03770

[™]iSBX is a trademark of Intel Corporation.

Circle 45 on Reader Service Card

Erase or program EPROMs all in one site

Erasogram-40[™] MultiProgrammer[™]/UV Eraser

- PC Based Menu Driven Software.
- Supports 24, 28 & 32-pin (E)EPROMs.
- EPROMs: 2716 up to 27513, plus 27010, 27011, 27C301.
- Fast Programming (2764 - 10 sec.) (27256 - 1 minute).
- EEPROMs: 2816 - 28C256.
- 8, 16 & 32-bit word programming.
- 60 minute timer (auto shut-off).
- Holds up to 30 chips.
- UV indicator.
- Safety interlock switch.
- One year warranty.
- 100% U.S.A. made.

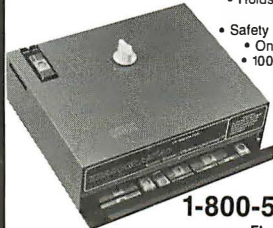

\$345.00

Call To Order

1-800-523-1565

FL: 1-407-994-3520

FAX: 1-407-994-3615 • TELEX: 4998369 BYTEK



BYTEK Corporation Instrument Systems Division
508 N.W. 77th Street
Boca Raton, FL 33487

Circle 51 on Reader Service Card

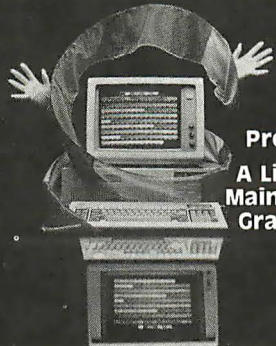

Presto!

**A Link to
Mainframe
Graphics**

Find out how our whole family of EMU-TEK graphics terminal emulation software makes good sense for the work you do. Call today for more information.

**FTG DATA
SYSTEMS**

(714) 995-3900

(800) 962-3900 (800) 972-3900 (Calif.)

10801 Dale St., Suite M-2
Stanton, CA 90680

Circle 109 on Reader Service Card

DATA ACQUISITION

ALL needs! ANY computer!

- PC Software Included
- Serial, Modem, & Bus
- Stand Alone Ability
- Laptop & Handheld
- PC & MAC Cards
- Inexpensive
- OEM & VAR
- RTU's



Call for FREE DEMO DISK!

Specialists in portable and battery backed up as well as PC compatible modular systems.



Call for applications info: (201) 299-1615
P.O. Box 246; Morris Plains, NJ 07950

ELEXOR

Circle 93 on Reader Service Card

NEW! MCPM-3 for
MC68HC05 Family



6805/6305
SINGLE CHIP

MICROCOMPUTER DEVELOPMENT SYSTEMS

Each of three products allows the IBM PS2/PC/XT/AT to be used as a complete development system for the Motorola 6805 series single chip microcomputers. MCPM-1 supports the MC68705 family, MCPM-2 supports the MC1468705 family and MCPM-3 supports the MC68HC05 family. Each system is \$495 and includes a programming circuit board or programmer with driver, cross assembler and simulator/debugger software. A system is also available for the HITACHI 63705 ZTAT micro.

THE ENGINEERS COLLABORATIVE

Route 3, Box 8C, Barton, VT 05822
(802) 525-3458 FAX (802) 525-3451

Circle 100 on Reader Service Card

8051 SIMulator

for the IBM PC/XT/AT

\$99

The 8051 SIM software package assists in the debug of 8051 family programs. A screen oriented, menu command driven program, 8051 SIM speeds development by allowing program execution and debug without a target system. A great learning tool as well.

8031DryICE \$199

Dry ICE is a debugger/emulator that supports the development of hardware and software using the 8031 microcontroller. The DryICE provides powerful functions to assist in the integration, debug, and test phase. Hardware connects between your target 8031 IC socket and CRT terminal or PC COM port.



HITech Equipment Corporation
9400 Activity Road
San Diego, CA 92126

(619) 566-1892

Circle 128 on Reader Service Card

NEW! **AMI 80386 MOTHERBOARDS** **Lower Pricing!**

New Full-Size 25MHz
Version Available!

"Our benchmarks demonstrate the superiority of the AMI-type
motherboard..." - Quoted from BYTE Magazine October 1988

JE3020/JE3025: The AMI 80386 baby motherboards are available in either 16MHz or 20MHz versions. The AMI 80386 motherboards fit into an XT, AT or Baby AT chassis so that the boards deliver 386 power/performance and AT compatibility in an XT footprint size. The motherboards are ideally suited for a variety of applications including Multiuser (Unix, Xenix, PC MOS), Networking (Novell, 3-Com), CAD applications (Autocad) and Multi-tasking (Windows, OS/2, Desqview). The boards feature one 8-bit slot, six 16-bit slots and one 32-bit slot that accommodates the memory card (supplied). Also features 80387-20 math coprocessor capability for the JE3025 and 80387-16 for the JE3020. Both motherboards are keyboard switchable between low and high speed and 1 or 0 wait states. The 20MHz board features a Norton SI rating of 24.2 in the 20MHz mode, while the 16MHz board features a Norton SI rating of 18.7 in the 16MHz mode. AMI BIOS ROMs are included. RAM is mounted on a 32-bit expansion card (included) which utilizes (72) 41256-100 256K chips (JE3025) to reach 2 Megabytes (the JE3020 utilizes 41256-120 chips). A daughterboard is available (Part No. JE3030) which accepts (72) 511000P-10 1Meg chips for an additional 8 Megabytes, bringing the total memory of the system to 10 Megabytes. BIOS options include built-in setup and diagnostics. Special features include 64K of high speed (45ns) static cache RAM on the motherboard and Video BIOS Shadow RAM, allowing for exceptionally fast video performance. • Size: 8.5" x 13" • Weight: 3 lbs. • One-Year Warranty

One-Year
Warranty!

16,
20 or
25 MHz!

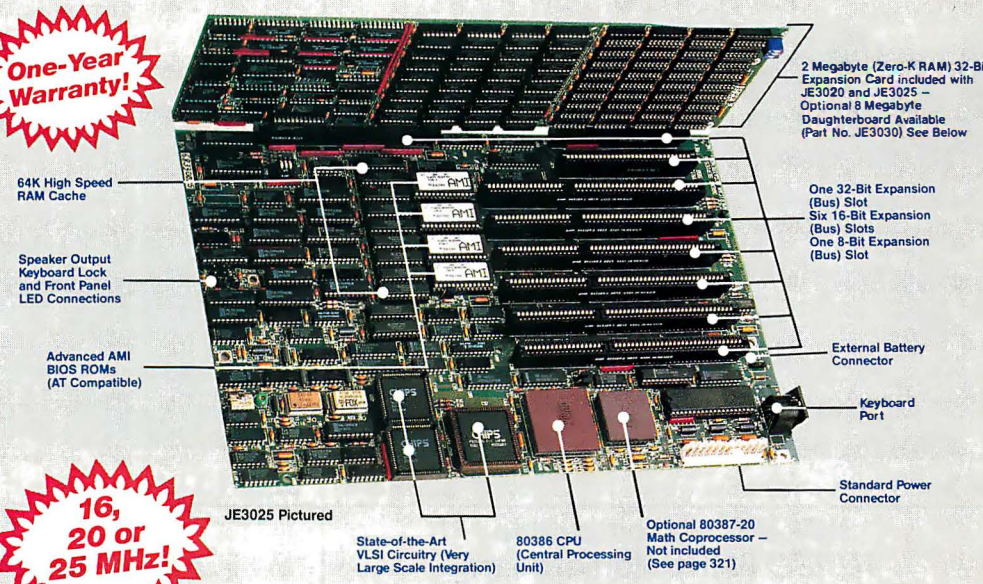

JE3030 -
8 Megabyte
Daughterboard
Option
(Zero-K RAM)

JE3026: This is the new full size 80386 25MHz speed demon from AMI. The JE3026 will fit into the new JE2010 tower case (see page 320F) or full size AT style cases. The board offers the same features as the JE3020/3025 with increased expandability and speed. The JE3026 features a Norton SI rating of 30.3 in the 25MHz mode. Also features 80387-25 or Weitek™ math coprocessor capability. The JE3026 is expandable to a total of 16 Megabytes using the JE3031 (not included - sold separately, see below). The JE3026 can be expanded to 8Mb on-board using (36) 511000P-80 and (4) 91000S-80 1Mb SIMM modules. The JE3031 is a 32-bit plug-in memory card which can be expanded to a total of 8Mb using (72) 511000P-80 1Mb chips for a total of 16Mb of RAM! When 4Mb DRAMs and SIMMs become available, the JE3026 is ready for them, allowing expansion to 32Mb on the motherboard, 48Mb with the JE3030/JE3031 combination. • Size: 12" x 13.75" • Weight: 3.25 lbs. • One-Year Warranty

See page 321 for RAMs and Math Coprocessors

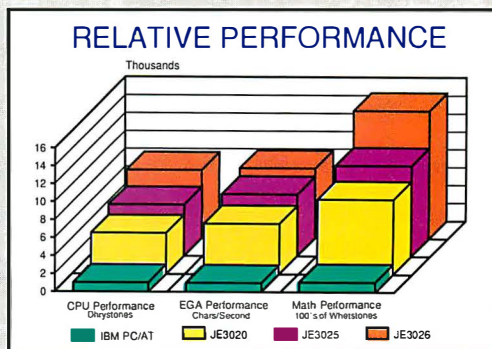

| Part No. | Description | Price |
|---------------|--|-----------------------------------|
| JE3020 | 16MHz 80386 AT Compatible Baby Motherboard (Zero-K RAM). | \$1399.95 \$1199.95 |
| JE3025 | 20MHz 80386 AT Compatible Baby Motherboard (Zero-K RAM). | \$1699.95 \$1499.95 |
| JE3026 | 25MHz AT Compatible Full-Size Motherboard (Zero-K RAM). | \$2299.95 |
| JE3030 | 8 Megabyte Daughterboard for JE3020 and JE3025 (Zero-K RAM). | \$299.95 \$249.95 |
| JE3031 | 8 Megabyte 32-bit Plug-In Card for the JE3026 (Zero-K RAM). | \$269.95 |



IBM AT Compatible 12MHz 80286 Motherboard

- Expandable to 1MB RAM using 256K DRAM chips☆
- Expandable to 4MB RAM using 1MB DRAM chips☆
- Uses 100ns DRAMs
- Battery-backed clock/calendar
- 8 or 12MHz hardware or keyboard selectable operation
- Front panel LED indicators supported
- Six 16-bit and two 8-bit expansion bus slots
- AMI BIOS ROMs included
- Selectable wait states (0 or 1)
- 80287-8 Math Co-processor capability☆
- Norton SI rating of 13.7
- Size: 13" x 8.75"
- Weight: 2.25 lbs.

One Year Warranty!

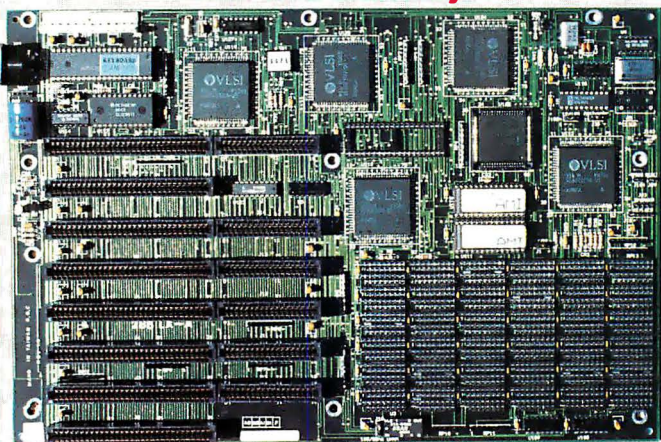

JE3005 80286 8/12MHz Motherboard . . . ~~\$329.95~~ \$299.95



IBM AT Compatible 16MHz 80286 NEAT Motherboard

- Expandable to 1MB RAM using 256K DRAM chips or 4MB using 1MB DRAM chips☆
- Additional 1MB with 256K DRAM SIPs or 4MB with 1MB DRAM SIPs for a total of 8MB☆
- Uses 100ns DRAMs
- Battery-backed clock/calendar
- 8/16MHz hardware or keyboard selectable
- Front panel LED indicators supported
- Five 16-bit and three 8-bit expansion bus slots
- AMI BIOS ROMs included
- Supports all NEAT functions including shadow RAM, EMS 4.0, RAM re-mapping, selectable wait states, etc.
- 80287-10 Math Co-processor capability☆
- Norton SI rating of 18.0
- Size: 13" x 8.5"
- Weight: 2.25 lbs.

One Year Warranty! Latest Technology!

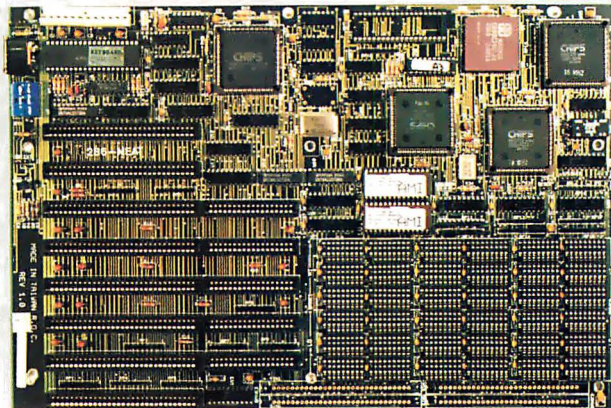

JE3010 80286 8/16MHz NEAT Motherboard ~~\$469.95~~ \$399.95

IBM PC/XT Compatible TURBO 8MHz Motherboard

- Expandable to 640K RAM using 4164 and 41256, 150ns chips☆
- 4.77 or 8MHz hardware or keyboard selectable operation
- Front panel LED indicators supported
- Eight expansion bus slots
- AMI BIOS ROMs included
- 8087-2 Math Co-processor capability☆
- Performs at an average speed of 75% faster than the original IBM PC/XT
- Norton SI rating of 1.7
- Size: 12" x 8.5"
- Weight: 1.75 lbs.

One Year Warranty!

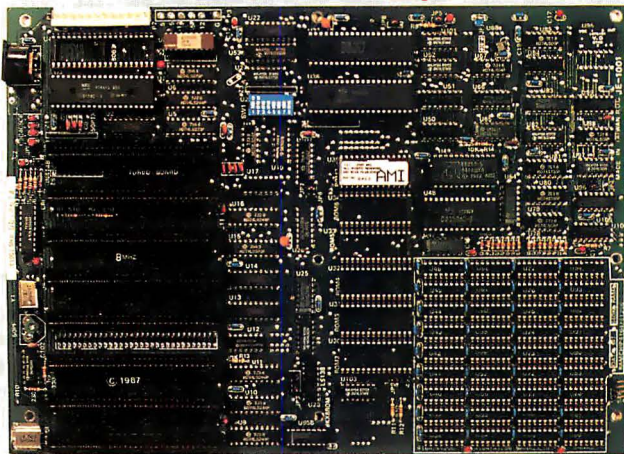

JE1001 8088 4.77/8MHz Motherboard ~~\$89.95~~

IBM PC/XT Compatible TURBO 10MHz Motherboard



- Expandable to 640K RAM using 4164, 41256 & 41464 120ns chips☆
- 4.77 or 10MHz hardware or keyboard selectable operation
- Front panel LED indicators supported
- Eight expansion bus slots
- AMI BIOS ROMs included
- 8087-1 Math Co-processor capability☆
- Performs at an average speed of 100% faster than the original IBM PC/XT
- Norton SI rating of 2.0
- Size: 12" x 8.5"
- Weight: 1.75 lbs.

One Year Warranty!

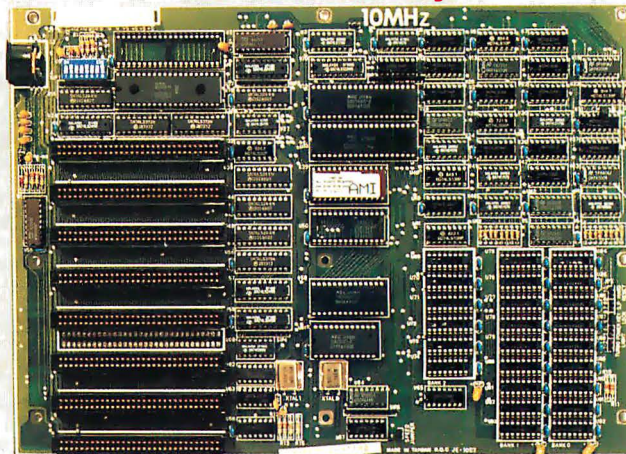

JE1002 8088 4.77/10MHz Motherboard . . . ~~\$109.95~~ \$99.95

☆ See page 321 for Dynamic RAMs and Math Coprocessors

Jameco's new IBM PC/XT/AT compatible kits allow you to build your own computer and come with complete step-by-step assembly instructions. **FREE Word Processing and Diagnostic Software included! NOW AVAILABLE... Jameco's new System Tech Manual (Part No. JETM...\$29.95) and DOS (Part No. EZDOS...\$49.95 or EZDOSP [EZDOS w/TrueBASIC]...\$69.95)**

Please note: JE3008 and JE3013 shipped in 1 box (43 lbs. total) — JE3002 and JE3003 shipped in 2 boxes (55 lbs. total)

IBM AT 12MHz Compatible Kit

- **Free! QAPLUS Diagnostic Software Included!**
- **Free! PC Write Word Processing Software Included!**
- **DOS Available** (See Above)
- **80286 CPU, Optional 80287-8 Math Co-processor Capability**
- **512K RAM Included—** See description on opposite page for expandability
- **8 or 12MHz Keyboard Switchable Operation**
- **Clock/Calendar**
- **AMI BIOS ROMs Included**
- **Save \$132.57**



Shown with EGA Option (not included)
JE1059 Monitor and Adapter Card \$499.95
(See page 320E)

| Part No. | Description | Price |
|----------------------------|---|------------------------------|
| JE3005 | 8/12MHz Baby AT Motherboard. | \$299.95 |
| | (Zero-K RAM — includes AMI BIOS ROMs) | |
| JE1016 | Enhanced AT Style Keyboard. | 69.95 |
| JE2019 | Baby AT Flip-Top Case. | 69.95 |
| JE1022 | 5.25" DSHD Disk Drive (Beige Bezel). | 99.95 |
| JE1032 | 200 Watt Power Supply. | 89.95 |
| JE1043 | 360K/720K/1.2MB/1.44MB Floppy Controller. | 49.95 |
| 41256-100 | 512K RAM (18 chips). | 152.82 |
| Save \$132.57 SALE! | | Regular List \$832.52 |
| JE3008 | 80286 12MHz Kit. | \$799.95 \$699.95 |

IBM AT 16MHz NEAT Compatible Kit

- **Free! QAPLUS Diagnostic Software Included!**
- **Free! PC Write Word Processing Software Included!**
- **DOS Available** (See Above)
- **80286 CPU, Optional 80287-10 Math Co-processor Capability**
- **2 Megabyte RAM Included, Expandable to 8 Megabyte**
- **8 or 16MHz Keyboard Switchable Operation**
- **Clock/Calendar**
- **AMI BIOS ROMs Included**
- **Save \$174.85**



Shown with VGA Option (not included)
JE2055 Monitor and Adapter Card \$599.95
(See page 320E)

| Part No. | Description | Price |
|----------------------------|---|-------------------------------|
| JE3010 | 8/16MHz NEAT AT Motherboard. | \$399.95 |
| | (Zero-K RAM — includes AMI BIOS ROMs) | |
| JE1016 | Enhanced AT Style Keyboard. | 69.95 |
| JE2019 | Baby AT Flip-Top Case. | 69.95 |
| JE1022 | 5.25" DSHD Disk Drive (Beige Bezel). | 99.95 |
| JE1032 | 200 Watt Power Supply. | 89.95 |
| JE1043 | 360K/720K/1.2MB/1.44MB Floppy Controller. | 49.95 |
| 511000P-10 | 2MB RAM (18 chips). | 395.10 |
| Save \$174.85 SALE! | | Regular List \$1174.80 |
| JE3013 | 80286 NEAT 16MHz Kit | \$1199.95 \$999.95 |

IBM PC/XT 8MHz Turbo Compatible Kit

- **Free! QAPLUS Diagnostic Software Included!**
- **Free! PC Write Word Processing Software Included!**
- **DOS Available** (See Above)
- **256K RAM Included, Expandable to 640K**
- **4.77 or 8MHz Switchable Operation**
- **Parallel Printer Port**
- **AMI BIOS ROM Included**
- **Save \$112.06**



| Part No. | Description | Price |
|----------------------------|---|------------------------------|
| JE1001 | 4.77/8MHz Turbo Motherboard. | \$89.95 |
| | (Zero-K RAM — includes AMI BIOS ROM) | |
| JE1010 | Flip-Top Case. | 34.95 |
| JE1015 | XT/AT Compatible Keyboard. | 59.95 |
| JE1020 | 5.25" DSDD Disk Drive (Black Bezel). | 89.95 |
| JE1030 | 150 Watt Power Supply. | 59.95 |
| JE1040 | 360K Floppy Controller. | 29.95 |
| JE1050 | Mono/Graphics Card with Printer Port. | 59.95 |
| AMBER | 12" Monochrome Amber Monitor. | 99.95 |
| 41256-150 | 256K RAM (9 chips). | 67.41 |
| Save \$112.06 SALE! | | Regular List \$592.01 |
| JE3002 | 8088 8MHz Turbo Kit | \$499.95 \$479.95 |

IBM PC/XT 10MHz Turbo Compatible Kit

- **Free! QAPLUS Diagnostic Software Included!**
- **Free! PC Write Word Processing Software Included!**
- **DOS Available** (See Above)
- **640K RAM Included**
- **4.77 or 10MHz Switchable Operation**
- **AMI BIOS ROM Included**
- **Multi I/O Card**
- **Save \$148.50**



| Part No. | Description | Price |
|----------------------------|--|------------------------------|
| JE1002 | 4.77/10MHz Turbo Motherboard. | \$ 99.95 |
| | (Zero-K RAM — includes AMI BIOS ROM) | |
| JE2014 | Turbo Flip-Top Case. | 69.95 |
| JE1015 | XT/AT Compatible Keyboard. | 59.95 |
| JE1021 | 5.25" DSDD Disk Drive (Beige Bezel). | 89.95 |
| JE1031 | Mini 150 Watt Power Supply. | 69.95 |
| JE1071 | Multi I/O with Controller, Graphics and Printer Port | 119.95 |
| AMBER | 12" Monochrome Amber Monitor. | 99.95 |
| 4164-120 | Parity RAM (2 chips). | 5.90 |
| 41256-120 | 512K RAM (18 chips). | 143.10 |
| 41464-12 | 128K RAM (4 chips). | 39.80 |
| Save \$148.50 SALE! | | Regular List \$798.45 |
| JE3003 | 8088 10MHz Turbo Kit | \$699.95 \$649.95 |

• REFER TO CODE 4038 WHEN ORDERING • SEE PAGE 322 FOR ORDER FORM • (415) 592-8097 320C

Pentagon Systems, Inc.

**Security Access Card
for IBM PC/XT/AT and
Compatible Computers**

The "Sergeant" is an access control card that prevents unauthorized access to your computer through user passwords.

Features: • Allows up to 10 programmable user passwords • Built-in software—no diskettes required for installation; just plug-in and go! • Fully menu-driven—no commands to remember • All resident software is in machine language, encrypted and is protected against intrusion and corruption attempts • Diskette locking capability • Owner/managers can monitor all usage and attempts to gain access • Passwords securely protected and accidental or intentional attempts to get to the passwords further secures them • Designed using EEPROM—requires no battery back-up • "Hacker Proof" because the ROM containing the core firmware is not accessible as it selectively turns itself off and on • Passwords may be assigned from remote locations (e.g. Corporate Headquarters) • Becomes transparent to all machine functions once a correct password has been accepted • Manual included • 1-Year Warranty

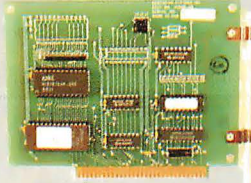

SAC1 Security Access Card..... \$149.95



Orchid Technology

**VGA Cards
for IBM PC/XT/AT & PS/2
Models 25 and 30**

Orchid VGA Cards provide you with the palette to create picture-perfect computer graphics. Ideal for use with VGA single frequency analog and multi-frequency monitors such as the QC1478 and TM5155 (see page 320E). In addition the GC1500 is compatible with monochrome TTL monitors (see page 320E).

GC1500 Features: • 8-bit card • Compatible with Hercules/MDA/MCGA/CGA/EGA and all 17 standard VGA modes plus 8 extended modes • Comes w/256K user upgradeable to 512K • 360 x 480 - 256 colors • Upgradeable to extended modes such as 800 x 600 - 256 colors • VGAspeed utility allows for a 250% increase in speed • Manual included • 4-Year Warranty

GC1501 Features: • Works with 8 or 16-bit computers • Compatible with MCGA/MDA/CGA/EGA and all 17 standard VGA modes • Comes w/256K user upgradeable to 512K • 360 x 480 - 256 colors • Upgradeable to extended modes such as 800 x 600 - 256 colors or 1024 x 768 - 16 colors • Auto mode switch, auto bus sense, auto monitor select and translation ROM included • VGA speed utility allows for a 250% increase in speed • Manual included • 4-Year Warranty

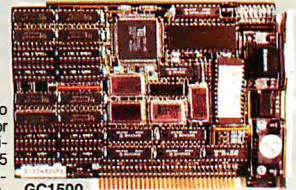

| Part No. | Description | Price |
|---------------|--------------------------------------|-------------------------------------|
| GC1500 | 8-bit VGA Card SALE! | \$269.95 \$249.95 |
| GC1501 | 8/16-bit VGA Card SALE! | \$349.95 \$329.95 |

**Monochrome
Graphics
Adapter
for IBM PC/XT/AT**

Compatible with
IBM Monochrome (MDA) and
Hercules Graphics Standards (HGA)



The JE1050 is a monochrome graphics card with parallel printer port and features the following: • Text mode: 80 x 25; Graphics mode: 720 x 348 • Compact half-card • Parallel printer interface with transfer rate of 1000 characters per second • Manual included

JE1050..... \$59.95

**Color Graphics
Adapter
for IBM PC/XT/AT**

Compatible with
IBM Color Graphics Standard (CGA)

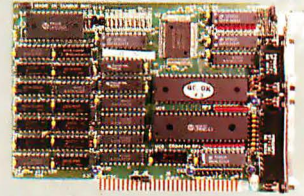

The JE1052 is a color graphics adapter card capable of operating with either IBM RGB or composite monochrome monitors and features the following: • Parallel printer port • Text modes: 40 x 25 or 80 x 25; Graphic modes: 320 x 200 or 640 x 200 • Light pen interface • Includes composite video monitor adapter • Manual included

JE1052..... \$49.95

**Enhanced Graphics
Adapter
for IBM PC/XT/AT**

Compatible with
IBM Enhanced Graphics Standard (EGA)

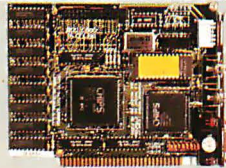

The JE1055 is an IBM EGA/CGA/MDA/HGA compatible card featuring the following: • Text mode: 80 x 25; Graphics mode: 720 x 348 • Reserved video jacks and feature connectors • Light pen interface • 256K Video RAM • Dipswitch on back of card allows changing of switch settings without opening case • Displays 16 colors from a palette of 64 • Manual included

JE1055..... \$159.95

**Multi I/O
with Controller
and Graphics
for IBM PC/XT**

Compatible with IBM Monochrome (MDA) and Hercules Graphics Standards (HGA)

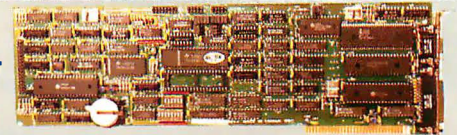

The JE1071 is a multi I/O card with six add-on functions, uses only one slot and features the following: • Text mode: 80x25; Graphics mode: 720x348 • One RS232C serial communication port (expandable to two - use Part No. SSP3) selectable for COM1 thru COM4 • Game port • Real-time clock/calendar with replaceable battery back-up • 5.25" floppy disk drive controller capable of handling up to two 360K drives • Parallel printer port • Print spooler software • Manual and cables included

JE1071..... \$119.95

**Floppy Disk Drive Controller Card
for IBM PC/XT and Compatible Computers**

• Run up to four 360KB disk drives • Includes cable for two internal drives • DC37S connector allows for an additional two external drives (external cable not included, use Part No. ECC) • Complete with manual

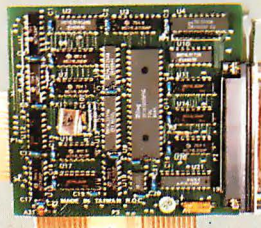

JE1040..... \$29.95

**360KB/720KB/1.2MB/1.44MB Floppy
Disk Drive Controller Cards
for IBM PC/XT/AT and Compatible Computers**

• The JE1043 allows connection of one or two 360KB, 720KB, 1.2MB or 1.44MB floppy disk drives • The JE1049 allows connection of up to four 360KB, 720KB, 1.2MB or 1.44MB floppy disk drives • JE1049 only: To add two external drives use cable Part No. ECC; to add two internal drives use cable Part No. TDC • Both units include cable for two internal disk drives and manual

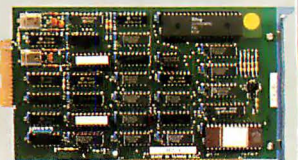

| | | |
|---------------|-------------------------|----------------|
| JE1043 | 2-Drive Controller..... | \$49.95 |
| JE1049 | 4-Drive Controller..... | \$59.95 |

JE1043

**Expansion Memory
Half-Card for IBM PC/XT
and Compatible Computers**

• Expands your system to the maximum 640K (zero-K on-board) • Accepts either 64K memory chips (4164) or 256K chips (41256) • Eight possible memory configurations ranging from 64K to 576K • Fits any slot (except slot 8 on IBM XT) • Recommended for systems running at 4.77MHz • Manual included

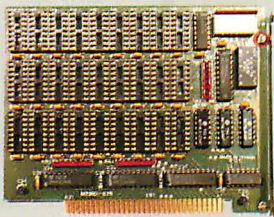

JE1080..... \$49.95

**2MB Memory
Expansion Cards
for IBM AT and
Compatible Computers**

• 2MB (zero-K on board) memory expansion cards for the IBM AT and compatible computers • JE1081 utilizes (72) 41256-120ns chips to reach 2MB • JE1083 utilizes (18) 511000P-10 chips to reach 2MB (JE1083 requires full 2MB for operation) • LIM EMS 4.0 drivers • Both cards offer conventional, expanded and extended memory capabilities • Auto-parity check • RAM disk and Print Spooler software included • Manual included

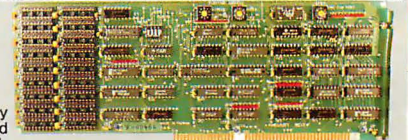

JE1083

| Part No. | Description | Price |
|---------------|--|-----------------|
| JE1081 | 2MB Expansion Card - Utilizes 41256-120 Chips (Zero-K) .. | \$119.95 |
| JE1083 | 2MB Expansion Card - Utilizes 511000P-10 Chips (Zero-K) .. | \$129.95 |

Quadrant 14" VGA Monitor and Orchid VGA Card for IBM PC/XT/AT and Compatible Computers

FREE! ColorIX VGA Paint Demonstration Disk Enclosed with every JE2055!

This VGA monitor is capable of very high resolution (up to 720 dots horizontal resolution) and meets the requirements for compatibility with a large number of today's VGA cards including the GC1500 and GC1501 (see p. 320D for further description). The QC1478 is also compatible with the PS/2 series computers. Monitor comes with tilt/swivel base, manual and cable.

QC1478 (Specs): • VGA Compatibility • Non-glare, tinted display, unlimited color capability • Input: DB15-pin High Density connector (Analog) • Scanning frequency: 31.5kHz • Resolution: 720 x 480 (max.) • Bandwidth: 30MHz • Size: 14.17"W x 14.84"D x 14.25"H • Weight: 26 lbs. • One-Year Warranty

GC1500 Features: • Ideal for use with VGA single frequency analog and multi-frequency monitors such as the QC1478 and TM5155 • Compatible with monochrome TTL monitors such as those below • 8-bit card • Compatible with all 17 standard VGA modes plus eight extended modes • Comes with 256K user upgradeable to 512K • 360 x 480 - 256 colors • Upgradeable to extended modes such as 800 x 600 - 256 colors • VGA speed utility allows for a 250% increase in speed • Manual included • Four-Year Warranty

| Part No. | Description | Price |
|---------------|---|-------------------------------------|
| QC1478 | 14" VGA Monitor..... | \$449.95 \$399.95 |
| GC1500 | Orchid VGA Card (Use with QC1478 or TM5155 Monitors) . . . | \$269.95 \$249.95 |
| JE2055 | QC1478 VGA Monitor and GC1500 Card SAVE \$50.00! . . . | \$649.95 \$599.95 |



Casper 14" EGA and Multiscan Monitors for IBM PC/XT/AT and Compatible Computers

The TM5154 EGA Monitor and TM5155 Multisync Monitor are ideal for text as well as CAD and other graphics applications. Both monitors come with a tilt/swivel base, manual and cable.

TM5154 (Specs): • EGA/CGA compatibility • Input: DB9 (TTL) • Scanning freq.: 15.75kHz to 21.85kHz • Resolution: 720 x 350 (max.) • Bandwidth: 25MHz • Size: 15"W x 14.25"D x 14"H • Weight: 35 lbs. • One-Year Warranty

| | | |
|---------------|---|-------------------------------------|
| TM5154 | 14" CGA/EGA Monitor..... | \$399.95 \$369.95 |
| JE1055 | EGA Card (Used with TM5154 and TM5155 Monitors) . . . | \$159.95 \$149.95 |
| JE1059 | TM5154 & JE1055 SAVE \$30.00 . . . | \$519.95 \$499.95 |

TM5155 (Specs): • MDA, CGA, EGA, PGC, VGA compatibility • DB9-pin male connector for TTL and DB15-pin adapter for analog input • Switch on back for TTL or Analog input • Scanning frequencies: 15.5kHz to 40kHz • Max. resolution: 800 x 600 • Bandwidth: 40MHz • Size: 15"W x 15"D x 13.5"H • Weight: 35 lbs. • One-Year Warranty

TM5155 14" MDA/CGA/EGA/PGC/VGA Monitor . . . ~~\$549.95~~ **\$499.95**



Quadrant 14" Flat Screen Amber and Paper White Monitors for IBM PC/XT/AT and Compatible Computers

These new flat screen 14" Amber and Paper White monitors are ideal for desktop publishing and CAD applications where limited distortion is desired. They feature a compact case with an anti-glare screen, an inverse video switch, a detachable tilt/swivel base, cable and manual.

Specifications: Input: • DB9 (TTL) • Bandwidth: 20MHz • Horizontal scanning frequency: 18.432kHz • Resolution: 1,000 lines (center) • Character Display: 80 characters x 25 rows • Size: 12.75"W x 12.2"D x 13.6"H • Weight: 16 lbs. • One-Year Warranty

| Part No. | Description | Price |
|----------------|--|-------------------------------------|
| QC1418 | 14" Flat Screen Monochrome Amber Monitor . . . | \$119.95 \$119.95 |
| QC1418P | 14" Flat Screen Paper White Monochrome Monitor | \$119.95 \$119.95 |

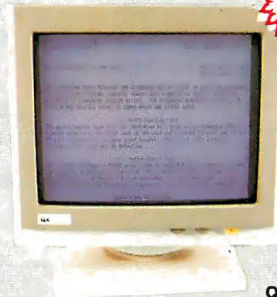

12" Amber Monochrome Monitor for IBM PC/XT/AT and Compatible Computers

• Input: DB9 (TTL) • Bandwidth: 20MHz • Horizontal scanning frequency: 18.432kHz • Character display: 80 characters x 25 rows • Weight: 19 lbs. • Size: 12.5"W x 12"D x 12"H • Compatible with JE1050, JE1055 and JE1071 (see page 320D) • Cable and manual included

AMBER..... \$99.95



Casper 14" RGB Color Monitor for IBM PC/XT/AT and Compatible Computers

• Input: DB9 (RGB) • Horizontal scanning frequency: 15.75kHz • Video bandwidth: 21MHz • Display area: 13.1" diagonally • Resolution: 640 x 240 • Switch for Green or Color Screen • Size: 14.6"W x 15.5"D x 13.6"H • Weight: 27 lbs. • Compatible with JE1052 and the JE1055 (see page 320D) • Cable and manual included • One-year warranty

HD55H..... \$249.95



NEW! ColorIX EGA and VGA Paint

These powerful EGA and VGA Paint programs give you the following and much more at a reasonable price: • Pop-up menus • Zoom image windows • Image library • Color mixing capability • Small function allows you to save your image in 50-90% less disk space • Text editing with 9 to 72 point and 34 contemporary fonts • Line smoothing capability • Capture capability • Mouse or keyboard operation • Print capability for almost any dot-matrix, color, or laser printer available • Slide show capability allows creation of presentations • Plus much, much more!

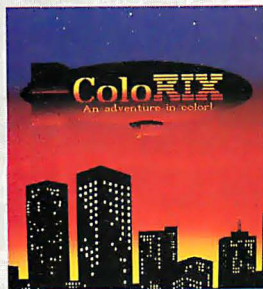

| Part No. | Description | Price |
|-------------|------------------------|-------------------------------------|
| EGAP | EGA Paint Program..... | \$89.95 \$79.95 |
| VGAP | VGA Paint Program..... | \$119.95 \$119.95 |

Glare Screen Filters Double-Sided, Black or Gray Frame to match your Computer!

These economical glare screen filters are available for either 12" or 14" monitors. The micro fine, super uniform nylon threads create a louver effect so that light entering at an angle can't get through to the screen and reflect back as glare. Light emitted from the CRT travels straight through for glare-free viewing. Both units attach with velcro and/or double sided tape (provided) and feature a double-sided black/gray frame to match today's contemporary design in computers.



| Part No. | Description | Price |
|-------------|------------------------------|-----------------------------------|
| GG12 | 12" Glare Screen Filter..... | \$9.95 \$9.95 |
| GG14 | 14" Glare Screen Filter..... | \$11.95 \$11.95 |



• REFER TO CODE 4038 WHEN ORDERING • SEE PAGE 322 FOR ORDER FORM • (415) 592-8097 320E

IBM PC/XT Compatible Flip-Top and Slide Cases

- Metal housing and chassis • Anti-static coated plastic face plate • Flip-top/Slide models available • Back plate set for 8 expansion card slots and power supply mount • Will hold up to a combination of 4 half-height floppy or hard disk drives • Color: grey • All necessary hardware incl. • Size: 19.5"W x 16.5"D x 5.75"H • Weight: 17 lbs.

**New Slide Version
Available!**



JE1010

JE1010 Flip-Top PC/XT Case... **\$34.95**
JE1011 Slide PC/XT Case... **\$39.95**

Tower Case with 250 Watt Power Supply

**Space and expandability in an
attractive floor mount case!**

- Will fit AT/386 Baby or Full (standard) size motherboards • Space saving floor-mount case • Metal housing and chassis • Anti-static coated plastic face plate • Back plate with 8 expansion slots • Switches for Turbo and Reset • Indicator lights for Power, Turbo mode, Hard Disk operation • Keyboard lock with 2-key set • Will hold up to a combination of 6 half-height floppy or hard disk drives • Includes 2-3.5" drive cages • All necessary hardware included • Color: Beige

Power Supply: • 250 Watt • Input: 90-130VAC @ 47-400Hz (110/220V switchable) • Output: +5V @ 26A, +12V @ 9A, -5V @ 0.5A, -12V @ 0.5A • Plug compatible connectors • Built-in fan

Tower Case Unit:
• Size: 7.325"W x 16.75"D x 25.25"H • Weight: 34 lbs.



NEW

JE2010 Tower Case w/250W Power Supply **\$299.95 \$279.95**

Baby AT Flip-Top Case

- Metal housing and chassis • Anti-static coated plastic face plate • Back plate with 8 expansion slots and power supply mount • Switches on front for Turbo mode and Reset • Indicator lights for Power, Turbo mode, Hard disk operation • Keyboard lock with 2-key set • Will hold up to a combination of 3 half-height floppy or hard disk drives • All necessary hardware is included • Color: Beige • Size: 17.125"W x 17"D x 6.5"H • Weight: 21 lbs.

New High Tech Design!



JE2019 Baby AT Case **\$69.95**

Baby XT Flip-Top Case

New High Tech Design

- Metal housing and chassis • Anti-static coated plastic face plate • Back plate with 8 expansion slots and power supply mount • Switches on front for Turbo and Reset • Indicator lights for Power, Turbo mode and Hard Disk operation • Keyboard lock with two key set • Will hold up to a combination of 3 half-height floppy or hard disk drives • All necessary hardware included • Color: Beige • Size: 14.5"W x 17"D x 6.75"H • Weight: 17 lbs.



JE2014 Flip-Top Baby XT Turbo Case **\$69.95**

IBM PC/XT Compatible 150 Watt Power Supplies

+5VDC @ 15A
-5VDC @ 0.5A
+12VDC @ 5.5A
-12VDC @ 0.5A

- Input: 90-130VAC @ 47-63Hz (110/220V switchable) • Output: +5V @ 15A, -5V @ 0.5A, +12V @ 5.5A, -12V @ 0.5A • Plug compatible connectors • Built-in fan • Size (JE1030): 5.5"W x 9.5"D x 4.625"H, Wt.: 6 lbs. • Size (JE1031): 6.25"W x 6"D x 6"H, Wt.: 5 lbs. • Spec. included



JE1030

JE1030 PC/XT... **\$59.95**
JE1031 Baby PC/XT... **\$69.95**

IBM AT Compatible 200 Watt and 250 Watt Power Supplies

200 Watt (JE1032):
+5VDC @ 20A
-5VDC @ 0.5A
+12VDC @ 8A
-12VDC @ 0.5A

250 Watt (JE1033):
+5VDC @ 26A
-5VDC @ 0.5A
+12VDC @ 9A
-12VDC @ 0.5A

JE1032: • Input: 90-130VAC @ 47-400Hz (110/220V switchable) • Output: +5V @ 20A, -5V @ 0.5A, +12V @ 8A, -12V @ 0.5A • Plug compatible connectors • Built-in fan • Size: 6.5"L x 5.88"W x 6"H • Weight: 6 lbs. • Spec. included

JE1032 200 Watt At Comp. Power Supply **\$89.95**

JE1033: • Designed to fit in popular tower cases • Input: 90-130VAC @ 47-400Hz (110/220V switchable) • Output: +5V @ 26A, -5V @ 0.5A, +12V @ 9A, -12V @ 0.5A • Plug compatible connectors • Built-in fan • Size: 8.33"L x 6"W x 5.94"H • Weight: 6.5 lbs. • Spec. included

JE1033 250 Watt AT Comp. Power Supply **\$119.95**



JE1032



JE1033

IBM PC/XT/AT Compatible 101-Key Enhanced Keyboard with Calculator

- Solar powered calculator offers ease and convenience of use • 101-key • Enhanced keyboard layout • Tactile touch keyswitches • 12 function keys • Illuminated LED indicators for Num Lock, Caps Lock and Scroll Lock • Separate cursor pad • Low profile design • Switchable between PC/XT or AT • Manual included • Color: Beige • Size: 19.5"W x 7.625"D x 1.5"H • Weight: 3.6 lbs.

JE2016 Enhanced PC/XT/AT Keyboard with Calculator **\$79.95**



NEW

**Solar
Powered
Calculator!**

IBM PC/XT/AT Compatible 84-Key Keyboard

- 84-key • AT style layout • Tactile touch keyswitches • Switch selectable between PC/XT or AT • Illuminated LED indicators for Num Lock, Caps Lock and Scroll Lock • Low profile design • Manual included • Color: Beige • Size: 19.5"W x 7.5"D x 1.33"H • Weight: 4.6 lbs.

JE1015... **\$59.95**



IBM PC/XT/AT Compatible 101-Key Enhanced Keyboard

- 101-key • Enhanced keyboard layout • Tactile touch keyswitches • 12 function keys • Illuminated LED indicators for Num Lock, Caps Lock & Scroll Lock • Separate cursor pad • Low profile design • Automatically switches between PC/XT or AT • Spec. included • Color: Beige • Size: 19"W x 8"D x 1.33"H • Wt.: 4.6 lbs.

JE1016... **\$69.95**



20 and 30 Megabyte Half-Height Hard Disk Drives for the IBM PC/XT/AT and Compatible Computers

Seagate Hard Disk Drives provide the IBM PC/XT/AT or compatible computers with 20 and 30 Megabytes of formatted capacity in a shock resistant, half-height package. These drives are easily installed and ideal for applications ranging from rugged industrial use to quiet office and home environments. High reliability is assured through the use of LSI and a single circuit board. The drives may be purchased with or without controller cards. Controller cards are capable of controlling two hard drives. Cables provided for connecting one hard drive only. 1-Year Warranty. Documentation included.

ST225 (20 Megabyte): • Available for PC/XT or AT • Track to track access time: 20 msec. max. • Average access time: 65 msec. • Data transfer rate: 5.0 Megabits/sec. • Tracks: 2,460 • Bytes per track (formatted): 8,704 • Read/Write Heads: 4 • Cylinders: 615 • Size: 5.75"W x 8"D x 1.63"H • Weight: 5 lbs.

| Part No. | Description | Price |
|----------------|---|-----------------|
| ST225 | 20MB Hard Disk Drive Only for IBM PC/XT/AT and compatibles (MFM Controller needed). | \$224.95 |
| ST225XT | 20MB Hard Disk Drive, MFM Controller and Cables for IBM PC/XT and compatibles. | \$269.95 |
| ST225AT | 20MB Hard Disk Drive, MFM Controller, Software and Cables for IBM AT and compatibles. | \$339.95 |



Seagate ST225XT 20MB Hard Disk Drive Kit

ST238 (30 Megabyte): • Available for PC/XT or AT • Track to track access time: 20 msec. max. • Average access time: 65 msec. • Data transfer rate: 7.5 Megabits/sec. • Tracks: 2,460 • Bytes per track (formatted): 13,312 • Read/Write Heads: 4 • Cylinders: 615 • Size: 5.75"W x 8"D x 1.63"H • Weight: 5 lbs.

| Part No. | Description | Price |
|----------------|---|-----------------|
| ST238 | 30MB Hard Disk Drive Only for IBM PC/XT/AT and compatibles (RLL Controller needed for operation). | \$249.95 |
| ST238XT | 30MB Hard Disk Drive, RLL Controller and Cables for IBM PC/XT and compatibles. | \$299.95 |
| ST238AT | 30MB Hard Disk Drive, RLL Controller and Cables for IBM AT and compatibles. | \$389.95 |



Seagate ST238XT 30MB Hard Disk Drive Kit

40MB, 60MB and 120MB Hard Disk Drives Available! Call for Information and Pricing.



HARD/FLOPPY CONTROLLER CARDS

NEW!

Hard Disk/Floppy Controller for IBM PC/XT and Compatible Computers

Connect up to Two Hard and Two Floppy Disk Drives!



The JE1044 is an 8-bit floppy and MFM hard disk controller for the IBM PC/XT and compatible computers. The JE1044 will allow connection of up to two hard disks and two floppy drives (360KB, 720KB, 1.2MB and 1.44MB). Cables are included to allow connection of one hard disk and two floppy disk drives. To connect a second hard disk drive an additional cable will be required (use Part No. HD2)

JE1044..... **\$129.95**

Hard Disk/Floppy Controller for IBM AT and Compatible Computers



The JE1045 is a 16-bit floppy and MFM hard disk controller for the IBM AT and compatible computers. The JE1045 will allow connection of up to two hard disk drives and any combination of two floppy disk drives (360KB, 720KB, 1.2MB and 1.44MB). Cables are included to allow connection of one hard disk and two floppy disk drives. To connect a second hard disk drive an additional cable will be required (use Part No. HD2).

JE1045..... **\$149.95**

RLL Hard Disk Controller Cards for IBM PC/XT/AT and Compatible Computers

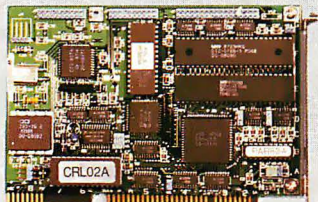

The JE1042 is an 8-bit RLL hard disk controller card for the IBM PC/XT and compatible computers. The JE1042 should be used with hard disks designed for RLL formatting such as the Seagate 30MB ST238, 60MB ST277 and 120MB ST4144. Cables and documentation included.

JE1042 RLL PC/XT Hard Disk Controller Card .. **\$99.95 \$89.95**

The JE1047 is a 16-bit RLL hard disk controller for the IBM AT and compatible computers. The JE1047 should be used with hard disks designed for RLL formatting such as the Seagate 30MB ST238, 60MB ST277 and 120MB ST4144. Cables and documentation included.

JE1047 RLL AT Hard Disk Controller Card..... **\$189.95**

MFM Hard Disk Controller Cards for IBM PC/XT/AT and Compatible Computers

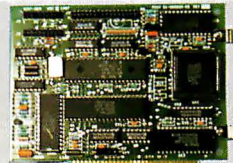

The JE1041 is an 8-bit MFM hard disk controller card for the IBM PC/XT and compatible computers. The JE1041 can be used with many types of hard disk drives including the Seagate 20MB ST225 and 40MB ST251/ST251-1. Cables and documentation included.

JE1041 MFM PC/XT Hard Disk Controller Card..... **\$79.95**

The JE1046 is a 16-bit MFM hard disk controller for the IBM AT and compatible computers. The JE1046 can be used with many hard disk drives including the Seagate 20MB ST225 and 40MB ST251/ST251-1. Cables and documentation included.

JE1046 MFM AT Hard Disk Controller Card..... **\$129.95**

• REFER TO CODE 4038 WHEN ORDERING • SEE PAGE 322 FOR ORDER FORM • (415) 592-8097 320G

Handheld Digital Multimeter

The Economical Choice for a High Quality, High Accuracy Digital Multimeter
 • 3.5 Digit (.5" High) LCD Readout • Audible Continuity Test • 1-Year Warranty

| RANGE | ACCURACY | RESOLUTION |
|-------------------|------------------|------------|
| AC VOLTAGE | | |
| 200mV | ±1.2% of reading | 100µV |
| 2V | ±0.8% of reading | 1mV |
| 20V | | 10mV |
| 200V | | 100mV |
| 700V | ±1.2% of reading | 1V |
| DC VOLTAGE | | |
| 200mV | ±0.5% of reading | 100µV |
| 2V | | 1mV |
| 20V | | 10mV |
| 200V | ±1.2% of reading | 100mV |
| 1000V | | 1V |

| RANGE | ACCURACY | RESOLUTION |
|-------------------|------------------|------------|
| AC CURRENT | | |
| 20µA | ±1.0% of reading | 10nA |
| 200µA | | 100nA |
| 2mA | | 1µA |
| 20mA | ±1.8% of reading | 10µA |
| 200mA | | 100µA |
| 2A | ±3.0% of reading | 1mA |
| 20A | | 10mA |
| DC CURRENT | | |
| 20µA | ±0.5% of reading | 10nA |
| 200µA | | 100nA |
| 2mA | | 1µA |
| 20mA | ±1.2% of reading | 10µA |
| 200mA | | 100µA |
| 2A | ±2.0% of reading | 1mA |
| 20A | | 10mA |

**High Quality,
Low Cost!**

| RANGE | ACCURACY | RESOLUTION |
|-------------------|------------------|------------|
| RESISTANCE | | |
| 200Ω | ±0.5% of reading | 0.1Ω |
| 2KΩ | | 1Ω |
| 20KΩ | | 10Ω |
| 200KΩ | ±1.0% of reading | 100Ω |
| 2MΩ | | 1KΩ |
| 20MQ | | 10KΩ |



Unit comes complete with probes, batteries, carrying case & manual. Size: 6.75"H x 3.5"W x 1.25"D
 Measures: AC/DC Voltage, AC/DC Current, Resistance, Diodes, Transistor hFE, Audible Continuity Test
 • Auto Zeroing • Input Impedance: 10MΩ • Overload Protection: 1000VAC/VDC • One-Year Warranty

M3800 3.5 Digit Multimeter. **\$39.95**

Handheld Digital Multimeters

• Jumbo 3.5 and 4.5 Digit (.7" High) LCD • Audible Continuity Test • Overload Protection
 • 1 Year Warranty • Ruggedized Case

AC Voltage (for M3610, M3650/B and M4650)

| RANGE | ACCURACY | | RESOLUTION | |
|-------|------------------|------------------|---------------|-------|
| | M3610/M3650/B | M4650 | M3610/M3650/B | M4650 |
| 200mV | ±1.2% of reading | ±0.5% of reading | 100µV | 10µV |
| 2V | ±0.8% of reading | | 1mV | 100µV |
| 20V | | | 10mV | 1mV |
| 200V | ±1.2% of reading | ±0.8% of reading | 100mV | 10mV |
| 750V | | | 1V | 100mV |

Resistance (for M3610, M3650/B and M4650)

| RANGE | ACCURACY | | RESOLUTION | |
|-------|------------------|-------------------|---------------|-------|
| | M3610/M3650/B | M4650 | M3610/M3650/B | M4650 |
| 200Ω | ±0.5% of reading | ±0.2% of reading | 0.1Ω | .01Ω |
| 2KΩ | ±0.5% of reading | ±0.15% of reading | 1Ω | 0.10Ω |
| 20KΩ | | | 10Ω | 1Ω |
| 200KΩ | | | 100Ω | 10Ω |
| 2MΩ | ±1% of reading | ±0.5% of reading | 1KΩ | 100Ω |
| 20MQ | | | 10KΩ | 1KΩ |

DC Voltage (for M3610, M3650/B and M4650)

| RANGE | ACCURACY | | RESOLUTION | |
|-------|------------------|------------------|---------------|-------|
| | M3610/M3650/B | M4650 | M3610/M3650/B | M4650 |
| 200mV | ±0.3% of reading | ±.05% of reading | 100µV | 10µV |
| 2V | | | 1mV | 100µV |
| 20V | | | 10mV | 1mV |
| 200V | ±0.3% of reading | ±0.1% of reading | 100mV | 10mV |
| 1000V | | | 1V | 100mV |

Capacitance (for M3650/B and M4650 only)

| RANGE | ACCURACY | | RESOLUTION | |
|--------|----------------|---------|------------|-------|
| | M3650/B/M4650 | M3650/B | M3650/B | M4650 |
| 2000pf | ±2% of reading | 1pf | 0.1pf | |
| 200nf | | 100pf | 10pf | |
| 20µf | | 10nf | 1nf | |

Frequency (for M3650/B and M4650 only)

| RANGE | ACCURACY | | RESOLUTION | |
|--------|----------------|---------|------------|-------|
| | M3650/B/M4650 | M3650/B | M3650/B | M4650 |
| 20KHz | ±2% of reading | 10Hz | 1Hz | |
| 200KHz | | 100Hz | 10Hz | |

All units come complete with probes, batteries, carrying case & manual. Size: 7"H x 3.5"W x 1.5"D

M3610: • Measures: AC/DC Voltage, AC Current (200µA to 20A), DC Current (200µA to 20A), Resistance, Diodes, Transistor hFE, Audible Continuity Test • Auto-Zeroing • Input Impedance: 10MΩ • Overload Protection: 1000VAC/VDC

M3610 3.5 Digit Multimeter. **\$49.95**

M3650: • Measures: AC/DC Voltage, AC Current (2mA to 20A), DC Current (200µA to 20A), Resistance, Diodes, Transistor hFE, Audible Continuity Test, Frequency and Capacitance • Auto-Zeroing • Input Impedance: 10MΩ • Overload Protection: 1000VAC/VDC

M3650 3.5 Digit Multimeter with Frequency and Capacitance Measurement. **\$69.95**

M3650B: • Same specs as the M3650 (above) except features a 40 point bargraph display

M3650B 3.5 Digit Multimeter with 40 point Bar Graph. **\$79.95**

M4650: • Measures: AC/DC Voltage, AC Current (2mA to 20A), DC Current (200µA to 20A), Resistance, Diodes, Transistor hFE, Audible Continuity Test, Frequency and Capacitance • Auto-Zeroing • Data Hold Switch • Input Impedance: 10MΩ • Overload Protection: 1000VAC/VDC

M4650 4.5 Digit Multimeter with Frequency/Capacitance Measurement and Data Hold Switch. **\$99.95**

NEW, BARGRAPH MODEL!



M3650B

4.5 DIGIT FOR UNDER \$100!



M4650

320H • **FOR COMPLETE PRODUCT LINE, REQUEST JAMECO'S 74-PAGE CATALOG • (415) 592-8097**

Mail Order Electronics - Worldwide

Jameco ELECTRONICS

Mail-Order Electronics

24 HOUR ORDER HOTLINE

415-592-8097

IC Clearance Sale!

Expires 5/31/89

NEC V20 & V30 CHIPS

Replace the 8086 or 8088 in Your IBM PC and Increase Its Speed by up to 30%! Price

| | | |
|-----------------------------------|---------|---------|
| UPD70108-5 (5MHz) V20 Chip..... | \$7.49 | \$ 6.49 |
| UPD70108-8 (8MHz) V20 Chip..... | \$9.49 | \$ 7.95 |
| UPD70108-10 (10MHz) V20 Chip..... | \$12.25 | \$10.95 |
| UPD70116-8 (8MHz) V30 Chip..... | \$9.95 | \$ 7.95 |
| UPD70116-10 (10MHz) V30 Chip..... | \$16.95 | \$15.49 |

7400

| Part No. | 1-9 | 10+ | Part No. | 1-9 | 10+ |
|-----------|------|------|------------|------|------|
| 7400..... | SALE | 15 | 7485..... | SALE | 45 |
| 7402..... | SALE | 29 | 7486..... | SALE | 29 |
| 7404..... | SALE | 15 | 7489..... | 1.95 | 1.85 |
| 7405..... | 35 | 25 | 7490..... | 49 | 39 |
| 7406..... | 39 | 29 | 7493..... | 45 | 35 |
| 7407..... | SALE | 25 | 74121..... | SALE | 35 |
| 7408..... | 35 | 25 | 74123..... | SALE | 35 |
| 7410..... | SALE | 15 | 74125..... | SALE | 35 |
| 7414..... | SALE | 25 | 74126..... | SALE | 35 |
| 7416..... | SALE | 19 | 74143..... | SALE | 35 |
| 7417..... | SALE | 19 | 74150..... | SALE | 1.10 |
| 7420..... | 29 | 19 | 74154..... | 1.35 | 1.25 |
| 7430..... | SALE | 15 | 74158..... | SALE | 1.25 |
| 7432..... | 39 | 29 | 74171..... | SALE | 3.95 |
| 7438..... | SALE | 25 | 74174..... | SALE | 35 |
| 7442..... | SALE | 29 | 74175..... | SALE | 35 |
| 7445..... | SALE | 59 | 74176..... | SALE | 49 |
| 7446..... | 69 | 59 | 74181..... | SALE | 1.49 |
| 7447..... | 89 | 79 | 74189..... | SALE | 1.49 |
| 7448..... | 1.95 | 1.85 | 74193..... | 79 | 69 |
| 7472..... | SALE | 25 | 74198..... | SALE | 1.25 |
| 7473..... | 39 | 29 | 74221..... | SALE | 69 |
| 7474..... | SALE | 25 | 74274..... | SALE | 35 |
| 7475..... | 49 | 39 | 74365..... | SALE | 35 |
| 7476..... | 45 | 35 | 74367..... | SALE | 35 |

74LS

| | | | | | |
|--------------|------|------|--------------|------|------|
| 74LS00..... | SALE | 15 | 74LS165..... | 75 | 65 |
| 74LS02..... | SALE | 15 | 74LS166..... | SALE | 69 |
| 74LS04..... | SALE | 16 | 74LS173..... | SALE | 25 |
| 74LS05..... | SALE | 16 | 74LS174..... | SALE | 25 |
| 74LS06..... | 59 | 49 | 74LS175..... | SALE | 25 |
| 74LS07..... | 59 | 49 | 74LS189..... | SALE | 2.95 |
| 74LS08..... | 59 | 49 | 74LS191..... | SALE | 3.95 |
| 74LS10..... | SALE | 15 | 74LS193..... | 69 | 59 |
| 74LS14..... | SALE | 29 | 74LS221..... | SALE | 49 |
| 74LS27..... | SALE | 19 | 74LS240..... | SALE | 45 |
| 74LS30..... | SALE | 19 | 74LS243..... | SALE | 45 |
| 74LS32..... | SALE | 19 | 74LS244..... | SALE | 49 |
| 74LS42..... | 49 | 39 | 74LS245..... | SALE | 59 |
| 74LS47..... | 89 | 79 | 74LS259..... | 39 | 29 |
| 74LS53..... | SALE | 45 | 74LS271..... | 69 | 59 |
| 74LS74..... | SALE | 19 | 74LS279..... | 49 | 39 |
| 74LS75..... | SALE | 25 | 74LS322..... | 3.49 | 3.39 |
| 74LS76..... | 39 | 29 | 74LS365..... | SALE | 35 |
| 74LS85..... | 59 | 49 | 74LS366..... | SALE | 35 |
| 74LS86..... | 29 | 19 | 74LS367..... | SALE | 49 |
| 74LS90..... | SALE | 29 | 74LS368..... | SALE | 35 |
| 74LS93..... | SALE | 29 | 74LS374..... | SALE | 59 |
| 74LS123..... | SALE | 35 | 74LS374..... | SALE | 49 |
| 74LS125..... | 49 | 39 | 74LS393..... | SALE | 79 |
| 74LS138..... | 49 | 39 | 74LS590..... | 5.95 | 5.85 |
| 74LS139..... | SALE | 29 | 74LS624..... | 1.95 | 1.85 |
| 74LS154..... | 1.19 | 1.09 | 74LS629..... | SALE | 1.95 |
| 74LS157..... | 45 | 35 | 74LS640..... | SALE | 49 |
| 74LS158..... | SALE | 25 | 74LS645..... | SALE | 89 |
| 74LS163..... | SALE | 35 | 74LS670..... | SALE | 79 |
| 74LS164..... | SALE | 35 | 74LS688..... | 2.39 | 2.29 |

74S/PROMS*

| | | | | | |
|-------------|------|-----|-------------|------|------|
| 74S00..... | SALE | 19 | 74S188..... | 1.49 | 1.49 |
| 74S04..... | SALE | 19 | 74S189..... | 1.49 | 1.49 |
| 74S08..... | SALE | 19 | 74S196..... | SALE | 99 |
| 74S10..... | SALE | 19 | 74S240..... | 1.39 | 1.39 |
| 74S32..... | SALE | 19 | 74S444..... | SALE | 1.99 |
| 74S47..... | SALE | 49 | 74S523..... | SALE | 29 |
| 74S85..... | SALE | 19 | 74S287..... | 1.49 | 1.49 |
| 74S86..... | SALE | 19 | 74S288..... | 1.49 | 1.49 |
| 74S124..... | SALE | 125 | 74S373..... | SALE | 99 |
| 74S174..... | SALE | 25 | 74S472..... | SALE | 2.49 |
| 74S175..... | SALE | 25 | | | |

CD-CMOS

| | | | |
|-------------|------|----------------|------|
| CD4001..... | 19 | CD4076..... | 59 |
| CD4008..... | 59 | CD4081..... | 22 |
| CD4011..... | 19 | CD4082..... | 22 |
| CD4013..... | 19 | CD4093..... | 35 |
| CD4016..... | 29 | CD4094..... | 89 |
| CD4017..... | 29 | CD4103..... | 1.49 |
| CD4018..... | 59 | CD4107..... | 49 |
| CD4020..... | 59 | CD4510..... | 69 |
| CD4024..... | 45 | CD4511..... | 69 |
| CD4027..... | 35 | CD4520..... | 75 |
| CD4030..... | 65 | CD4522..... | 79 |
| CD4040..... | 65 | CD4538..... | 79 |
| CD4049..... | 29 | CD4541..... | 79 |
| CD4050..... | 29 | CD4543..... | 89 |
| CD4051..... | 29 | CD4553..... | 3.95 |
| CD4052..... | 59 | CD4555..... | 7.95 |
| CD4053..... | 59 | CD4563..... | 1.95 |
| CD4063..... | 1.49 | CD4566..... | 1.95 |
| CD4066..... | 29 | CD4583..... | 5.95 |
| CD4067..... | 1.49 | CD4584..... | 49 |
| CD4069..... | 1.49 | CD4585..... | 69 |
| CD4070..... | 29 | MC1441 1P..... | 7.95 |
| CD4071..... | 22 | MC1449 0P..... | 4.99 |
| CD4072..... | 22 | | |

EPR0MS

| | | | |
|---------------|--------|------------------------------------|-------|
| 2816A..... | 2048x8 | 35ns (10V-15V) 5V Read/Write | 5.25 |
| 2816A-25..... | 2048x8 | 25ns (10V-15V) 5V Read/Write | 5.49 |
| 2817A..... | 2048x8 | 35ns 5V Read/Write | 6.95 |
| 2864A..... | 8192x8 | 35ns 5V Read/Write (Pin 1, No R/B) | 13.95 |
| 2864A-30..... | 8192x8 | 30ns 5V Read/Write (Pin 1, No R/B) | 12.95 |
| 2865A-30..... | 8192x8 | 30ns 5V Read/Write | 14.95 |
| 52813..... | 2048x8 | 35ns (21V) 5V Read Only | 1.95 |

MICROPROCESSOR COMPONENTS

| MISCELLANEOUS CHIPS | | 8000 SERIES Continued | | 8000 SERIES Continued | |
|-------------------------------|-----------|-----------------------|-------------|-------------------------|--------|
| Part No. | Price | Part No. | Price | Part No. | Price |
| D765AC..... | 3.95 2.95 | 8087(5MHz)..... | 94.95 | 8748H (HMOS) (21V)..... | 9.95 |
| WD9216..... | 3.95 | 8087-1(10MHz)..... | 184.95 | 8749..... | 9.95 |
| Z80, Z80A, Z80B SERIES | | 8087-2(8MHz)..... | 134.95 | 8751 (3.5-8MHz)..... | 37.95 |
| Z80..... | 1.19 | 8088(5MHz)..... | 4.95 3.49 | 8751H (3.5-12MHz)..... | 39.95 |
| Z80-CTC..... | 1.29 99 | 8088-2(8MHz)..... | 6.95 5.95 | 8755..... | 12.95 |
| Z80-PIO..... | 1.29 99 | 8116..... | 4.95 3.95 | 80286-10 LCC..... | 59.95 |
| Z80A..... | 1.29 | 8155..... | 2.49 | 80287-8 (8MHz)..... | 149.95 |
| Z80A-CART..... | 1.29 | 8155-2..... | 3.49 | 80287-10 (10MHz)..... | 209.95 |
| Z80A-DTC..... | 4.95 3.95 | 8166..... | 2.95 | 80386-16 PGA..... | 279.95 |
| Z80A-PIO..... | 1.99 1.49 | 8212..... | 2.29 | 80387-16 (8MHz)..... | 395.95 |
| Z80A-SIO/0..... | 3.95 2.95 | 8224..... | 2.29 | 80387-20 (20MHz)..... | 459.95 |
| Z80B..... | 2.75 | 8224..... | 2.29 | 80387-25 (25MHz)..... | 565.95 |
| Z80B-CTC..... | 3.95 3.25 | 8228..... | 1.49 | 80387-SX (16MHz)..... | 369.95 |
| Z80B-PIO..... | 3.95 | 8237..... | 1.75 | 82284 (8MHz)..... | 9.49 |
| Z80B-SIO..... | 4.95 | 8243..... | 1.75 | 82288 (8MHz)..... | 9.95 |
| Z8671..... | 7.95 | 8250A..... | 4.95 3.95 | | |
| Z8681B1..... | 8.95 | 8250B (For IBM)..... | 6.95 4.95 | | |
| 8000 SERIES | | 8251A..... | 1.95 | | |
| 8031..... | 3.95 3.49 | 8252-5..... | 3.95 | | |
| 80C31..... | 3.95 8.95 | 8253..... | 3.95 | | |
| 8035..... | 1.49 1.25 | 8255A-5..... | 2.95 | | |
| 8039..... | 1.95 1.59 | 8255-B..... | 2.95 | | |
| 8052A-HBASIC..... | 1.95 | 8259..... | 3.95 2.95 | | |
| 8080A..... | 2.95 1.49 | 8279-5..... | 2.95 2.75 | | |
| 8085A..... | 2.49 | 8741..... | 9.95 | | |
| 8086..... | 2.95 | 8742..... | 19.95 17.95 | | |
| 8086-2..... | 6.95 5.49 | 8748 (25V)..... | 7.95 | | |

STATIC RAMS

| Part No. | Function | Price |
|-----------|--------------------------------|-------------|
| 2016-12 | 2048x8 120ns | 3.75 2.95 |
| 2016-15 | 4Kx5 300nM | 6.95 |
| 2102 | 1024x4 350ns | 89 |
| 2114N | 450ns | 99 79 |
| 2114N-2L | 1024x4 200ns Low Power | 1.49 |
| 21C14 | 1024x4 200ns CMOS | 5.95 |
| 21C14 | 4096x8 CMOS | 2.49 |
| 6116P-1 | 2048x8 100ns (16K) CMOS | 3.95 3.19 |
| 6116P-3 | 2048x8 150ns (16K) CMOS | 3.49 2.79 |
| 6116P-1 | 2048x8 100ns (16K) LP CMOS | 4.99 3.59 |
| 6116P-3 | 2048x8 150ns (16K) LP CMOS | 2.99 109 |
| 6264P-10 | 8192x8 100ns (64K) CMOS | 9.95 9.49 |
| 6264P-15 | 8192x8 100ns (64K) CMOS | 9.95 7.49 |
| 6264P-10 | 8192x8 100ns (64K) LP CMOS | 10.95 10.25 |
| 6264P-15 | 8192x8 100ns (64K) LP CMOS | 10.95 8.95 |
| 6264P-15 | 8192x8 150ns (64K) LP CMOS | 10.95 7.95 |
| 6514 | 1024x4 350ns CMOS | 3.75 3.49 |
| 43256-10L | 32,768x8 100ns (256K) LowPower | 23.95 |
| 43256-15L | 32,768x8 150ns (256K) LowPower | 22.95 |
| 62256P-85 | 32,768x8 85ns (256K) LP CMOS | 26.95 |
| 62256P-10 | 32,768x8 100ns (256K) LP CMOS | 24.95 |
| 62256P-12 | 32,768x8 120ns (256K) LP CMOS | 24.25 |

DYNAMIC RAMS

| | | |
|-------------|-------------------------------|---------------|
| THM91000-10 | 1,048,576x9 100ns Merg 9 S/P | 599.95 329.95 |
| THM91000-15 | 1,048,576x9 150ns Merg 9 S/P | 599.95 299.95 |
| THM91000-80 | 1,048,576x8 80ns Merg 9 S/P | 499.95 349.95 |
| THM91000-80 | 1,048,576x8 80ns Merg 9 S/M | 499.95 339.95 |
| TMS4416-12 | 16,384x4 120ns | 6.75 5.95 |
| TMS4416-15 | 16,384x4 150ns | 6.75 4.49 |
| 4116-15 | 16,384x4 150ns (MM5290W-2) | 1.39 25 |
| 4118-15 | 131,072x1 150ns (PgyBack) | 5.29 |
| 4164-100 | 65,536x1 100ns | 3.49 |
| 4164-120 | 65,536x1 120ns | 2.95 |
| 4164-150 | 65,536x1 150ns | 2.59 |
| 4164-180 | 262,144x1 60ns | 14.99 10.99 |
| 41256-80 | 262,144x1 80ns | 14.99 8.95 |
| 41256-100 | 262,144x1 100ns | 9.76 8.49 |
| 41256-120 | 262,144x1 120ns | 8.95 7.95 |
| 41256-150 | 262,144x1 150ns | 8.99 7.49 |
| 41264-12 | 64Kx4 120ns Video RAM | 19.95 |
| 41464-10 | 65,536x4 100ns | 14.49 11.95 |
| 41464-12 | 65,536x4 120ns | 14.95 9.95 |
| 41464-15 | 65,536x4 150ns | 16.95 8.95 |
| 51258-10 | 262,144x1 100ns Static Column | 11.95 |
| 85227-10FL | 262,144x9 100ns 256Kx9 S/P | 14.95 10.95 |
| 85227-10PS | 262,144x9 100ns 256Kx9 S/M | 14.95 10.95 |
| 51100P-10 | 1,048,576x1 100ns (1 Meg) | 25.95 21.95 |
| 51100P-15 | 1,048,576x1 150ns (1 Meg) | 25.95 24.95 |
| 51100P-85 | 1,048,576x1 85ns (1 Meg) | 35.95 23.95 |
| 514256P-10 | 262,144x4 100ns (1 Meg) | 34.95 29.95 |

EPROMS

| | | |
|-----------|------------------------------|-----------|
| TMS2516 | 2048x8 450ns (25V) | 6.95 5.95 |
| TMS2532 | 4096x8 450ns (25V) | 5.95 4.95 |
| TMS2532A | 4096x8 450ns (12.5V) | 4.45 3.25 |
| TMS2564 | 8192x8 450ns (25V) | 6.95 5.95 |
| TMS2716 | 2048x8 450ns (-5V, +5, +12V) | 6.95 4.49 |
| 1702A | 256x8 (1us) | 4.95 |
| 2708 | 1024x8 450ns | 6.95 |
| 2716 | 2048x8 450ns (25V) | 3.75 |
| 2716-1 | 2048x8 350ns (25V) | 4.65 3.95 |
| 27C16 | 2048x8 450ns (25V) CMOS | 4.65 3.75 |
| 2732 | 4096x8 450ns (25V) | 3.95 |
| 2732A-20 | 4096x8 200ns (21V) | 4.25 |
| 2732A-25 | 4096x8 250ns (21V) | 3.95 |
| 2732C | 4096x8 450ns (25V) CMOS | 4.95 4.25 |
| 2764-20 | 8192x8 200ns (21V) | 4.25 |
| 2764-25 | 8192x8 250ns (21V) | 3.59 |
| 2764-35 | 8192x8 350ns (21V) | 3.39 |
| 2764A-25 | 8192x8 250ns (12.5V) | 3.69 |
| 2764A-35 | 8192x8 350ns (12.5V) CMOS | 5.95 |
| 27128-20 | 16,384x8 200ns (21V) | 6.95 4.49 |
| 27128-25 | 16,384x8 250ns (21V) | 6.95 4.49 |
| 27128A-15 | 16,384x8 150ns (12.5V) | 7.75 |
| 27128A-20 | 16,384x8 200ns (12.5V) | 5.75 5.25 |
| 27128A-25 | 16,384x8 250ns (12.5V) | 5.75 4.95 |
| 27128-25 | 16,384x8 250ns (21V) CMOS | 8.95 |
| 27256-15 | 32,768x8 150ns (12.5V) | |

RS-232C/422A USERS: BI-DIRECTIONAL CONVERTER for EXTENDED USE

Convert RS-232C to
RS-422A and/or
RS-422A to RS-232C
only **\$49.95**



MODEL 422CON

Guaranteed satisfaction. Bi-directional, first-quality, versatile converter. Extends cable lengths up to 4,000 feet! Bit rates up to 90K Baud. (Two B & B RS-422CON Converters can extend your RS-232C capability up to 4,000 ft.)

Includes male DB25P connector for RS-232C and includes female DB25S connector for RS-422A. No handshaking lines connected. Requires 12V DC at 100 ma. Optional power supply available for only \$14.95.

Order Direct from Manufacturer **TODAY** and **SAVE!** * **SAME-DAY SHIPMENT! MONEY-BACK GUARANTEE!**

Request our **FREE** catalog listing B & B ELECTRONICS' comprehensive line of RS-232C Interface and monitoring equipment.

* Terms: Visa, MC, cash orders pos only. P.O.'s from qualified rated firms accepted. IL residents add 6 1/2% sales tax.

B & B electronics
MANUFACTURING COMPANY

4002E Baker Road • P.O. Box 1040 • Ottawa, IL 61350

Phone: 815-434-0846

DIGITAL VOICE CARD (DVC) for IBM PC, XT, AT and compatibles



GET A VOICE CARD TODAY AND LET YOUR PC DO THE TALKING.

The DVC comes complete with driver software and demonstration programs in C, BASIC, PASCAL and DBASE. It is simple to program and ready for use. A built-in VLSI voice processor handles the chore of digitizing and modulation. It digitizes voice input at 8K samples per second, 10 bits A/D, D/A. Voice data are transferred between processor and memory through selectable DMA channels. The recording and playback are done concurrently with user programs and with minimal CPU overhead. It does not tie up CPU time while processing the voice data. The DVC can continuously record and playback voice for up to 170 minutes on a 20M harddisk.

APPLICATIONS

- Sales, exhibit presentation
- Voice message management in a store, factory, office, and hospital
- Computerized security and monitoring system
- Voice alarm and reminder for busy executives
- Speech analysis and voice synthesis
- Voice mail on a floppy or through a modem
- Voice question and answer
- Sound-effect in games and simulation
- Voice output for industrial control/automation

DVC (Digital Voice Card for IBM PC/XT/AT) \$95.00
DVC (Microphone for DVC) \$12.00
SPK (Speaker for DVC) \$9.00
VPB (Voice in a Box, up to 32 seconds) \$80.00
VPB-II (up to 64 seconds) \$95.00
We accept VISA, Mastercard, to order in U.S. please call Computer Age Ltd. Tel: (416) 859-0370 Fax: (416) 859-0772

1-800-263-7487

Circle 35 on Reader Service Card

Circle 60 on Reader Service Card

maxell

| | 2-4 BOX | 5-9 BOX | 10+ BOX |
|-----------|------------------|------------------|------------------|
| 5 1/4" DS | 6 ⁵⁵ | 6 ⁴⁵ | 6 ³⁰ |
| 5 1/4" HD | 12 ⁰⁰ | 11 ⁷⁵ | 11 ⁵⁰ |
| 3 1/2" DS | 14 ⁰⁰ | 13 ⁷⁵ | 13 ⁵⁰ |
| 3 1/2" HD | 34 ⁵⁰ | 33 ⁸⁰ | 33 ²⁵ |

IBM

DISKETTES

| | | |
|----------|---------|---------|
| 5.25 DS | 6023450 | — 14.60 |
| 5.25 HD | 6109660 | — 32.50 |
| 3.5 DS | 6404107 | — 23.95 |
| 3.5 HD | 6404078 | — 45.95 |
| 2 D-1024 | 1669045 | — 33.95 |

RIBBONS

| | | |
|-----------------|-----------|---------|
| PROPRINTER | (6328829) | — 5.60 |
| PROPRINTER XL | (1040150) | — 7.99 |
| PROPRINTER X24 | (1040475) | — 8.10 |
| PROPRINTER XL24 | (1040414) | — 11.90 |
| PROPRINTER II | (6328829) | — 5.60 |
| MONO PRINTER | (1040440) | — 12.95 |
| QUIETWRITER | (1299790) | — 9.45 |
| QUIETWRITER III | (1299933) | — 13.95 |
| DISPLAYWRITER | (1299463) | — 8.95 |

Verbatim

A KODAK COMPANY

Verbatim Saves You Money Time After Time After Time

| | 2-4 BOX | 5-9 BOX | 10+ BOX |
|-----------|------------------|------------------|------------------|
| 5 1/4" DS | 6 ⁶⁵ | 6 ⁴⁵ | 6 ³⁰ |
| 5 1/4" HD | 13 ⁴⁰ | 13 ²⁰ | 12 ⁹⁵ |
| 3 1/2" DS | 14 ²⁵ | 13 ⁹⁵ | 13 ⁷⁵ |
| 3 1/2" HD | 34 ⁵⁰ | 33 ⁸⁰ | 33 ²⁵ |

the Diskette Connection

- Delaware 1-800-451-1849
P.O. BOX 10247, WILMINGTON, DE. 19850
- Oklahoma 1-800-654-4058
P.O. BOX 1674, BETHANY, OK. 73008
- Nevada 1-800-621-6221
P.O. BOX 12396, LAS VEGAS, NV. 89112

Minimum order \$20.00. No Surcharge on Visa Master Card. COD orders add \$3.00. Surface Shipping UPS add \$3.00 per 100 for 3 1/2" or 5 1/4", add \$4.00 per 100 for 8". U.S. Mail delivery add 9%. Prices subject to change without Notice.

TELEX 4933362 FAX (405) 495-4598

DYNAMIC RAMS

| SIMM | 80/100 | \$CALL |
|---------|--------|----------------|
| 1 MBIT | 100ns | \$18.50 |
| 514256 | 100ns | \$23.00 |
| 41464 | 150ns | \$ 7.95 |
| 41256 | 120ns | \$ 7.95 |
| ✓ 41256 | 150ns | \$ 7.25 |
| ✓ 51258 | 100ns | \$ 8.25 |
| ✓ 4164 | 150ns | \$ 2.65 |

| PROCESSORS | | PROMS | |
|------------|-------------------|---------|----------------|
| 80387-25 | 25MHz \$495.00 | 27C101 | 250ns \$ 23.00 |
| 80387-20 | 20MHz \$395.00 | 27C512 | 200ns \$ 13.00 |
| 80387-16 | 16MHz \$325.00 | 27F12 | 250ns \$ 8.50 |
| 80287-12 | 12MHz \$295.00 | 27C256 | 250ns \$ 5.25 |
| 80287-10 | 10MHz \$235.00 | 27256 | 250ns \$ 4.75 |
| 80287-8 | 8MHz \$208.00 | 27128A | 250ns \$ 4.50 |
| 8087-1 | 10MHz \$178.00 | 27C64A | 200ns \$ 4.25 |
| 8087-2 | 8MHz \$135.00 | 2764 | 250ns \$ 3.50 |
| V-30 | 8MHz \$ 12.75 | S. RAMS | |
| V-20 | 8/10MHz \$ 8.5/15 | 43256 | 120ns \$ CALL |
| | | 4364 | 150ns \$ 8.95 |

I.C. EXPRESS

15358 Valley Blvd. City of Industry, CA 91746 Tel: 818-369-2688
ORDER TOLL FREE (Mon-Fri 8-5 PST)
(800) 892-8889 • (800) 882-8181
outside California inside California
CALL FOR CURRENT PRICES & VOLUME DISCOUNTS.
Price Shown for cash. MasterCard/Visa add 3%. Prices are subject to change. Minimum order \$10.00. Shipping & Handling: UPS Ground \$5.00, Air \$7.00 (1 lb.) ALL MERCHANDISE IS 100% GUARANTEED WITH PROMPT DELIVERY.

Circle 131 on Reader Service Card

Circle 189 on Reader Service Card

Why is a FORTUNE 500 company using THIRD® in it's production line?

Because THIRD® does:

- statistical process control in real time
- 200 samples per minute
- on four independent production lines
- from an inexpensive AT clone

Now THIRD® v.2 with EGA/VGA graphics & foreground/background execution

- Sample Disk \$5, Visa or MC



TRILOBYTE, INC.
596 ABOLICION ST.
HATO REY, P.R. 00918
TEL (809) 767-1839

Circle 271 on Reader Service Card

Universal Programmer

for IBM-PC/XT/AT



START FROM
\$399

- Programs logic and memory devices with 40 pins or less.
- Support transmission format such as Intel Hex, Motorola's S, Tektronix Hex, ASCII Hex, Hexadecimal, & JEDEC.
- Support functional test and provide fusemap edit for logic device.
- Support split/shuffle programming facility and provide memory edit for memory device.

2 YEARS GUARANTEE + 30 DAYS MONEY BACK WARRANTY

Xender Corporation
2824 KENNEDY BLVD. 1FL, JERSEY CITY, NJ 07306
TEL: 201-659-8291 Tlx: 900 240 444 CHAMPION
Fax: 201-864-9737

Circle 294 on Reader Service Card

AVPROM™ \$295

For IBM-PC's & compatibles, menu-driven AVPROM programs EPROMs up to 8x faster than serially-connected units (20 sec. for 2764).

- Programs 2716 thru 27512A.
- 4- and 10 socket gang versions too. Call for prices.

For complete specs, free 32 pg. development tool catalog, call

800-448-8500.
or 207-236-9055

AVOCET
SYSTEMS, INC.:

120 Union St., Rockport, ME 04856

Circle 30 on Reader Service Card

PAL/EPROM PROGRAMMER for PC

VERSION 2 of Software and Hardware \$475

- Programs 20 and 24 pin MM1, NS, TI, Altera, Cypress, Ricoh/Panasonic PALs, EPLD (UV erasable), polarity, and RA types.
- Functions Include: read, write, verify, protect, edit, print, and file load and save of program.
- JEDEC files supported.
- 2716-27512 EPROMs.
- Functions Include: read, write, verify, blank check, H/A/O split, edit in ASCII, HEX, or Decimal.
- INTEL Hex and Motorola "S" Record file support.

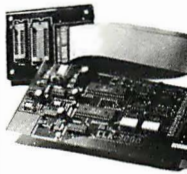

200/100 MHz LOGIC ANALYZER for PC

- 24 Channel mode with 4K/channel • 6 Channel mode with 16K/channel
- Internal Rates from 200MHz(LA2700) or 100MHz(LA27100) to 250 Hz
- External Clock from DC to 50 MHz • 16 Level Triggering Sequence
- Threshold Voltage Level at TTL ECL, or -RV to +RV variable • Data Display as Timing Diagram or State List • Save/Load Data and Setup Info.

(201) 994-6669
Link Computer Graphics, Inc.
4 Sparrow Dr., Livingston, NJ 07039

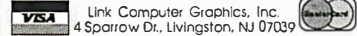

Circle 153 on Reader Service Card

SAVE ON 9 TRACK TAPE SYSTEM

FOR IBM PC/XT/AT
& PS-2

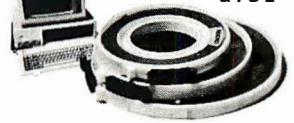

- Mainframe to PC Data Transfer
- High Speed Backup
- All Software, Complete System
- Service and Support, easy Installation

call (818) 343-6505 or write to:

CONTECH Computer Corp.
P.O. Box 153 Tarzana, CA 91356

CONTECH

Circle 68 on Reader Service Card

IMAGING CARD

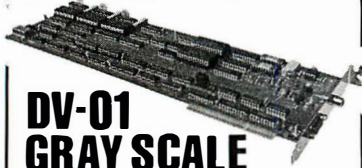

DV-01 GRAY SCALE FRAME GRABBER

Composite video in/out
256 x 240 resolution
Digitize/display at frame speed
256 gray levels in
16 Meg. color palette out
PC/XT/AT compatible

\$849.00 Complete with software
VISA/MC Demo Disk available

Control Vision

P.O. Box 596, Pittsburg, KS 66762
(316) 231-6647

Circle 69 on Reader Service Card

EPROM PROGRAMMER CROSS ASSEMBLERS



MODEL
SX151

RS232C OR STAND ALONE (all models), Communication protocol: XMODEM, HEX, and BIN. Programs: EEPROMS, 2716 - 27512 and CMOS. Programs (w/adaptor): 25XX, 27101 (and above), 68701, 68705, 68764/6, 8741/2, 8744, 8748/9, 8751/2, 8755, 87252, and CMOS. More available soon. Model SX151 \$214 (assembled with case). Other models are available from \$49 (kit).

Cross assemblers by PseudoCode for IBM-PCs, \$50. Z80, 1802, 6502, 68001/12/13/5/8/9/11, 68000/8/10, 8048/9, 8051/2, 8080/5, 8096, and more soon. Simulators and disassemblers also available.

KORE, Inc.
6910 Patterson S.E.
Caledonia, MI 49316
(616) 791-9333

\$5 for shipping (USA), plus \$3.00 COD.

Circle 146 on Reader Service Card

TurboFlow \$69

Flowchart drawing for IBM PC/XT/AT/PS2

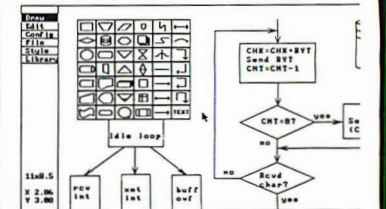

\$89 with Logitech mouse!

- Pop-up icon menus
- Variable size symbols
- Paper size to 34" x 44"
- Hercules mono, CGA, EGA
- HP-GL, DM/PL, SweetP Plotters
- Automatic PANning to scan drawing quickly
- IBM/EPSON, NEC, OKIDATA, HP LaserJet

Daytron Electronics, Inc.

610 S. Sherman #104, Richardson, Tx 75081
Add s&h (\$4 USA, \$15 foreign), Texas residents add 8% sales tax
For technical information call 214-669-2137

Order Today! 1-800-882-5822

Money-back guarantee

Circle 235 on Reader Service Card

Terminal Emulation

TEK 4105/4010

- Tektronix 4105
- Tektronix 4010/4014
- VT220, VT102
- Picture files
- VGA and EGA support
- High resolution hardcopy

VT220

- VT220, VT102 emulation
- File transfer
- 132 column modes
- Color support
- Hot key

■ ■ ■ Diversified Computer Systems, Inc.

3775 Ins Avenue, Suite 1B
Boulder, CO 80301 (303) 447-9251
FAX 303-447-1406

Trademarks VT102, VT220 — DEC, Tektronix — Tektronics Inc

Circle 87 on Reader Service Card

Dynamic Electronics

SIMMS

CALL FOR PRICES

| INTEL | DRAMS | SIMMS |
|---------|-------|-----------|
| 8087 | 64K | 256 X 8 |
| 80287 | 256K | X9 |
| 80387 | 4464 | 1 Meg X 8 |
| 80387SX | 1 Meg | 1 Meg X 9 |
| 80C287A | | |

Phone 714-855-0411

Fax: 714-855-8504

23522 COMMERCE CENTER DR. #L
LAGUNA HILLS, CA 92653, USA

Circle 89 on Reader Service Card

REAL WORLD I/O For PC/XT/ATs

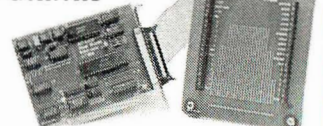

- DG24 • 24 line digital I/O: 10 Mhz 8255. \$95
- AD500 • 8 channel 12-bit (plus sign) integrating A/D; prog. gains of 1, 10 & 100; 7 digital I/O lines. \$239
- AD100 • Single channel version of AD500; 10 digital I/O lines. Same programmable gains. 700 meg input Z. \$149
- AD1000 • 8 channel 12-bit A/D; 25 uS; sample & hold; 3.5 Mhz timer/counters; 24 digital I/O lines. \$295
- ADA300 • 8 channel 8-bit 25 uS A/D; single D/A sample & hold; 24 digital I/O lines. \$239
- AD200 • 4 channel 12-bit 125 uS A/D; 3.5 Mhz timer/counters; 24 digital I/O lines. \$239
- DA600 • Fast settling dual bipolar D/A. \$179
- PD200 • Prototype board w/ address decoder; manual \$99

All boards include BASIC, Pascal, C, and Forth drivers. 30 day return; 1 year warranty. Call for "Real World Interfacing" application notes.

Real Time Devices, Inc.
P.O. Box 906 State College, PA 16804
(814) 234-8087

Circle 235 on Reader Service Card

LOW-LOW-LOW

hp Laserjet Printer Series II \$1650
hp Scanjet Scanner + interface kit \$1355

IBM **Compaq** **Apple** **Acer**
EVEREX **AST** & other

XT/AT Compatibles & 386 Computers
 CALL for LOW PRICES

Gov't, Corporate, Schools, Dealers,
 & Export INQUIRIES WELCOME.

SURAH inc.

44862 Osgood Road, FREMONT, CA 94539
 PH: (415) 651-5101 FAX: (415) 651-5241
 1-800-543-1001
 VISA, Master Card accepted. w/s

Circle 255 on Reader Service Card

Cross-32 Meta Assembler

Table based macro cross-assembler using the manufacturer's assembly mnemonics.

Includes manual and MS-DOS assembler disk with tables for all of the following processors:

| | | | |
|--------|--------|--------|---------|
| 1802 | 64180 | 65C02 | 65816 |
| 6801 | 6805 | 6809 | 68HC11 |
| 680X0 | 80X86 | COP400 | COP800 |
| 8048 | 8051 | 8085 | 8096 |
| TMS320 | TMS370 | Z8/Z80 | ...MORE |

Users can create tables for other processors!

Generates listing, symbol table and binary, Intel, or Motorola hexcode.

Free worldwide airmail shipping & handling.

Check, MO, VISA or MC: US\$199 or CN\$249

Universal Cross-Assemblers
 POB 384, Bedford, NS
 Canada B4A 2X3
 (902) 864-1873

Circle 276 on Reader Service Card

New

100% Autorouter

HiWIRE-Plus provides the integrated schematic-capture and PCB layout versatility needed by leading-edge designers. Now it also offers an advanced 100% autorouter. Affordably! See the full-page ad (on page 5) then call Wintek at:

(800) 742-8428

Circle 292 on Reader Service Card

NEW! **BIG MOUTH**™ VERS. 2.0

REAL VOICE Digital Recording for your PC, XT, AT or Compatible

- ◆ VOICE MAIL SYSTEM
- ◆ TELEMARKETING - Inbound & Outbound
- ◆ SMARTEST ANSWERING MACHINE
- ◆ AUTODIALER—DATABASE
- ◆ VOICEPAD™ - Voice for your Programs
- ◆ PROGRAMMER'S TOOLKIT - (optional '79⁹⁰)

1/2 card, software, cables, and speaker

\$269⁹⁰ + 5 s/h

(415) 652-9600
 Talking Technology, Inc.
 4383 Piedmont Ave. Suite B
 Oakland, CA 94611

Circle 257 on Reader Service Card

PROGRAMMERS FOR IBM PC/XT/AT

- Select Device with vender name & type number directly
- Enable user to set up Program Pulse Width, Vpp, Vcc, Over-program Pulse Width & Iteration Counts.
- Capable of set & 8/16/32-bits wide—word programming.

| | | |
|----------|---|-------|
| XP6000A | Adapter & cable installs in PC for connecting programmer externally | \$55 |
| XP6001 | 1-socket 1M-bits EPROMs programmer | \$160 |
| XP6002 | 8-socket 1M-bits EPROMs programmer | \$375 |
| XP6003 | 1-socket MCS-48 micros programmer | \$215 |
| XP6004 | 1-socket MCS-51 micros programmer | \$270 |
| XP6014 | 4-sockets 1M-bits EPROM programmer | \$260 |
| AT-101/A | EPROM Eraser erases 30 24-pin ICs with timer | \$195 |

Xender Corporation
 2824 KENNEDY BLVD., F.L., JERSEY CITY, NJ 07306
 TEL: 201-659-8291 TX: 910 240 4444 CHAMPION
 Fax: 201-864-9737

Circle 295 on Reader Service Card

IN STOCK!

SIMMS

1 MEG x 9 100 NS

BEST PRICES ANYWHERE!

Major electronics mfg.
 17 yrs. industry exper.
 will sell 1 or 1,000.

XENTEK SIMMS MART

800-748-5505

Circle 296 on Reader Service Card

E(E)PRO.M, MEMORY CARD & MICRO PROGRAMMER

\$345 - \$950

- No personality modules for E(E)Proms & Intel Micros.
- All 24/28/32 pin EPROMs/EEPROMs to 4 MBit (upgr. to 32MB).
- Flash EPROMs; Micros: 8741,-2,-8,-8H,-9,-9H,-51,-CS1,-52,-55 ...
- Memory Cards: Seiko/Epson, Mitsubishi, GI. Modular design.
- ON-BOARD Programming capability. Easy F/W upgrades.
- Stand-alone E(E)Prom & Memory Card Duplication / Verify.
- User friendly menu - driven driver for IBM-PC & Macintosh.
- Autobaud RS232 to any computer. Hex/Binary/Intel/Motorola.
- Built-in Eraser/Timer option (\$50). Gang-Module ready.
- Open board units starting from \$245. (OEM discounts available)
- Direct technical support. Dedicated BBS. Full 1 year warranty.

INTELLIGENT PROM EMULATOR (IBM-PC) **\$395**

- Emulates 2716 through 27512 (2k to 64k bytes) with a single unit
- Intelligent features include: Reset Output, Address Compare, Address Snapshot, Trigger Input, Program Editing capabilities.
- FAST data loading via parallel port (64k bytes in less than 10sec).
- After loading program unit can be disconnected from host for stand alone operation (9V battery backup).
- User friendly software; Functions include: Load, Write, Display, Edit, Monitor, Help, Calculator, Reset and more.
- Cascadable up to 8 units. Selectable wordsizes.
- Accepts Binary, Intel Hex and Motorola S formats.

MC/VISA/AMEX *Call today for datasheets!*

B&C MICROSYSTEMS INC.
 355 WEST OLIVE AVE. SUNNYVALE, CA 94086
 TEL.: (408)730-5511 FAX: (408) 730-5521

LOW COST INTERFACE CARDS FOR PC/XT/AT/PS2

RS-485/422 Card [PC485] **\$95/125**

- Serial Async. Communication up to 4,000ft; 2 or 4 wires; NS16450 UART;
- Can be configured as COM1-COM4; Maximum Baud Rate 56KB/115KB.
- Dual drivers/receivers; Handles 64 devices; Compatible with most comm. softw.
- DB9 or phonejack. Sample communication software available - \$50/150.

IEEE-488 Card [PC488A] **\$145**

- Includes INSTALLABLE DOS DEVICE DRIVERS and support for BASIC.
- Additional Support for ASSEMBLY, C, Pascal and FORTRAN - \$ 50.
- IR @ (1-6). DMA channel 1 or 2. Up to 4 boards per computer.
- Compatible with most IEEE-488 Software packages for IBM-PC (e.g. ASYST-TASK-FPIB, Lotus Measure). Compatible with NIS GPIB-PC/IIA.

IEEE-488 Card [PC488B] With Built-In Bus Analyzer **\$345**

- Software Support for BASIC, QuickBASIC and GWBASIC.
- Additional libraries for C, Pascal, FORTRAN, Assembly available - \$95 (all)
- Powerful menu-driven BUS ANALYZER runs in the background while 488 programs or commands are executed; Features Program Stepping, Break points, real time bus data capture (4K buffer), instant screen toggling.
- Complete Controller / Talker / Listener capability. Based on TIS TMS-9914.
- NEC-7210 based card (compatible with Nat. Instruments PCII/PCIIA) - \$445.

PS2 Ser/Par Card [PS2IOA] **\$95/125**

- I/O card for PS2 Models 50-80. Ser. port 1-2; Par. port 1-3; IBM registered ID.

A/D + D/A + DIO + Counter **\$295-995**

- Input channels: 16 single, 8 differential; A/D Resolution: 12 to 14 bits;
- Conversion speed 25,000 - 100,000 samples/sec; Input Range (+/-) 1 - 10V
- D/A: 2 channels; Resolution: 12 to 14 bits; Settling time: 3 usec. Range: 0-5V
- Digital I/O: 16 Out, 16 In; TTL compatible; Counter: 16 bits programmable.
- Compatible with ASYST, LABTECH, UnkelScope, DADISP.

MC/VISA/AMEX *Call today for datasheets!*

B&C MICROSYSTEMS INC.
 355 WEST OLIVE AVE. SUNNYVALE, CA 94086
 TEL.: (408)730-5511 FAX: (408) 730-5521

Circle 37 on Reader Service Card

3M

***FREE! FLIP'N'FILE**
***NEW 3M Formatted Diskettes**

| DS-DD | Quantity Discounts Available | DS-HD |
|--|---|---------------------------|
| .63* | 5 25" 3M Diskettes 10/box | *1.15 |
| 1.29* | 3 50" 3M Diskettes 10/box | *2.99 |
| 1.89 | SS/DD 8 00" 3M Diskettes | DS/DD 2.15 |
| .39 | 5.25" DS/DD 3M Highland Diskettes | 5.25" DS/HD 1.2mb .79 |
| DC-2000 | 12.50 | DC-600XTD 19.40 |
| DC-300XLP | 22.83 | DC-600A 21.45 |
| 3M Mag. Tapes Std w/seal 2400' | 12.50 | |
| 3M Mag. Tapes Std w/seal 1200' WTS | 9.25 | |

BASF

***FREE MICRODEX/25**

| DS-DD | Quantity Discounts Available | DS-HD |
|-------|---|-------|
| .57 | 5 25" BASF Diskettes 10/box | .89 |
| 1.19* | 3 50" BASF Diskettes 10/box | 2.89 |
| .34 | 5.25" BASF NoLogo Diskettes with Tyvek sleeves, labels & w/p. | |
| .48 | 5.25" BASF SS/DD/48 TPI Diskettes in BASF plastic library box | |

maxell

***FREE Plastic Library Box**

| MD2-DMP | MD2-HMP | MF2-DDMP | MF-2HD |
|---------|---------|----------|--------|
| .65* | 1.19* | 1.35* | 3.29 |

Verbatim

***FREE DataLife Plus with DISCUS 11th Disk!**

| 5.25" DS/DD | 5.25" DS/HD | 3.50" DS/DD | 3.50" DS/HD |
|-------------|-------------|-------------|-------------|
| .63* | 1.19 | 1.35 | 3.29 |

COLOR DISKETTES

| 5.25" DS/DD | 5.25" DS/HD | 3.50" DS/DD |
|-------------|-------------|-------------|
| .39 | .79 | 1.19 |

All 5.25" color diskettes in Tyvek sleeves, labels & w/p

BULK DISKETTES

| 5.25" DS/DD | 5.25" DS/HD | 3.50" DS/DD |
|-------------|-------------|-------------|
| .29 | .59 | .99 |

All 5.25" color diskettes in Tyvek sleeves, labels & w/p

3M Highland

***Incredible Value!!!**

| DS-DD | Quantity Discounts Available | DS-HD |
|-------|------------------------------|-------|
| .39 | 5.25" 3M Highland Diskettes | .79 |

RIBBONS STORAGE

— Please call for information —

TERMS: No surcharge on VISA, Mastercard or AMEX. COD only add \$3.00. Prepaid orders deduct 2% cash discount. PO's accepted from recognized institutions and corporations on Net 30. Bank draft, T/T or L/C acceptable. **Shipping:** \$4/100 or fewer disks. Reduced shipping charges on larger quantities. Price quoted for case (100 disks) quantities less than a case add 5% (Min order \$25.00)

WE BEAT ANY PRICE!

Toll Free Order Line: **1-800-523-9681**
Information Line: **1-801-255-0080**
TLX-9102404712 FAX-801-572-3327

DISKOTECH

DISCO TECHNOLOGIES, INC.

213 Cottage Avenue
P.O. Box 1339 Sandy, Utah 84091

9-Track Tape Subsystem for the IBM PC/XT/AT



Now you can exchange data files between your IBM PC and any mainframe or mini-computer using IBM compatible 1600 or 6250 BPI 9-Track tape. System can also be used for disk backup. Transfer rate is up to 4 megabytes per minute on PCs and compatibles. Subsystems include 7" or 10 1/2" streaming tape drive, tape coupler card and DOS compatible software. For more information, call us today!

QUALSTAR

9621 Irondale Ave., Chatsworth, CA 91311
Telephone: (818) 882-5822

Circle 220 on Reader Service Card

ON TARGET ASSOCIATES

Products and Services for Design and Manufacturing Engineers.

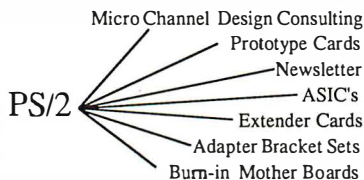

We will move your PC/XT/AT products to the Micro Channel, or create your new design.

CALL: (408) 980-7118 for our Free catalog

ON TARGET
TARGET
TARGET

...the PS/2 leaders.

PS/2 and Micro Channel are trademarks of IBM Corp.

Circle 193 on Reader Service Card

Z80 HD64180

MICROPROCESSORS

C Compiler
Assembler/Linker
Remote Debug
Realtime Kernel
Emulator
PC Coprocessors
Proto Board

Integrated Software/Hardware Targeted for Z80/64180 Development on PC/XT/AT Platforms:

| | |
|--|----------|
| C-compiler (UNIX & ANSI std.) | \$495.00 |
| Assembler/linker | \$195.00 |
| In-circuit Emulator | \$995.00 |
| Source/symbolic debugger | \$195.00 |
| Multitasking kernel | \$395.00 |
| Standalone Proto Board(64180µP) | \$295.00 |
| PC Coprocessors--many versions, please inquire | |

Z-World Engineering

1340 Covell Blvd., Suite 101
Davis, CA 95616
(916) 753-3722

Fax: (916) 753-5141



"Z80 Specialists"

In Germany: 08131/1687

Circle 300 on Reader Service Card

Communications Analyzer

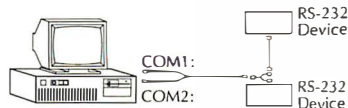

- Monitors and stores to disk RS232 async data in real time
- Dual line DCE over DTE format
- Perform action on any data pattern
- Interactive mode
- Fully configurable, includes cables
- For IBM/PC/XT/AT or compatibles



Palladian Technologies Incorporated \$395.00 demo \$10

1-800-537-5046 (301)576-0575

Circle 199 on Reader Service Card



Sure it's insured?

SAFEWARE® Insurance provides full replacement of hardware, media and purchased software. As little as \$39/yr. covers:

- Fire • Theft • Power Surges
- Earthquake • Water Damage • Auto Accident

For information or immediate coverage call:
1-800-848-3469

In Ohio call 1-614-262-0559

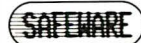

SAFEWARE, The Insurance Agency Inc.

Circle 239 on Reader Service Card

INTELLIGENT RS-232/422/485

- *COMMUNICATIONS
- *CONTROL
- *SYSTEMS DEVELOPMENT

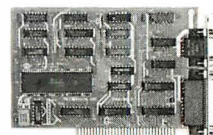

- *Hitachi HD64180 µP (6 or 9 mhz)
- *SBX connectors, 256K-516K RAM
- *2 Serial Ports & 2 DMA channels

Z-World Engineering

1340 Covell Blvd., Ste. 101
Davis, CA 95616

(916) 753-3722 Germany: 08131/1687

Circle 301 on Reader Service Card

A-BUS™ MAGIC

Classroom to advanced industrial applications.

Be a Wizard in your Lab, Factory, College, Home...

It used to be difficult and costly to do process control, robotics, data acquisition, monitoring and sensing with your computer. Now the low-cost A-BUS system makes it easy to do almost any project you can imagine.

Versatility. A-BUS cards handle most interfacing, from on/off switching, to reading temperatures, to moving robot arms, to counting events, to sensing switches...

Adaptability. The A-BUS is modular, allowing expansion well beyond your needs. It works with almost any computer, or even as a remote data station with the new serial adapters.

Simplicity. You can start using the A-BUS in minutes. It's easy to connect, and software is a breeze to write in any language.

Reliability. Careful design and rugged construction make the A-BUS the first choice in specialized I/O.

An A-BUS system consists of: - An A-BUS adapter plugged into your computer - A cable to connect the adapter to 1 or 2 A-BUS function cards. - The same cable will also fit an A-BUS Motherboard for expansion to up to 25 cards in any combination.



NEW: REMOTE A-BUS! Use the new Serial (RS-232) Adapter or Processor to control any A-BUS system. Cards can be up to 500 ft away using phone type cable, or off premises using a modem. Call or send for the new A-BUS Catalog which covers all the products.

Important

All A-BUS Systems: ♦ Come assembled and tested ♦ Include detailed manuals with schematics and programming examples ♦ Can be used with almost any language (BASIC, Pascal, C, assembler, etc.) using simple "IN" and "OUT" commands (PEEK and POKE on some computers) ♦ Can grow to 25 cards (in any combination) per adapter ♦ Provide jumper selectable addressing on each card ♦ Require a single low cost unregulated 12V power supply ♦ Are usually shipped from stock. (Overnight service is available.)

About Alpha Products

Founded in 1976 for the purpose of developing low cost I/O devices for personal computers, Alpha has grown to serve over 70000 customers in over 60 countries. A-BUS users include many of the Fortune 500 (IBM, Hewlett-Packard, Tandy, Bell Labs, GM...) as well as most major universities. A-BUS products are U.S. designed, U.S. built, and serviced worldwide. Overseas distributors: England: Cady Science Assoc. Ltd., Merseyside, 051 342 7033. Australia: Brumby Technologies Pty. Ltd., NSW, 759 1638. France: Cosem, Rungis, 46 66 64 75

Inputs, Outputs, etc.

Analog Input: 8 analog inputs. 0-5.1V in 20mV steps (8 bits). 0-100V range possible. 7500 conversions/second. **AD-142: \$142**

12 Bit A to D: Analog to digital converter. Input range -4V to +4V, expandable to 100V. On-board amplifier. Resolution 1mV. Conversion time 130ms. 1 channel. (Expand to 8 channels with the RE-156 card.) **AN-146: \$153**

Relay Card: 8 individually controlled industrial relays each with status LED's (3A at 120VAC contacts, SPST). **RE-140: \$142**

Reed Relay Card: 8 reed relays (20mA at 60VDC, SPST). Individually controlled and latched, with status LEDs. **RE-156: \$109**

D/A converter: 4 Channel 8 Bit D/A converter with output amplifiers and separate adjustable references. **DA-147: \$149**

24 line TTL I/O: Connect 24 input or output signals (TTL 0/5V levels or switches). Variety of modes. (Uses 8255A) **DG-148: \$72**

Digital Input: 8 optically isolated inputs. Input can be 5 to 100V voltage levels or switch closures. **IN-141: \$65**

Digital Output Driver: 8 outputs: 250mA at 12V. Drive relays, solenoids, stepper motors, lamps, etc. **ST-143: \$78**

Clock with Alarm: Powerful clock/calendar. Battery backup. Timing to 1/100 sec. Alarm relay, LED and buzzer. **CL-144: \$98**

Touch Tone Decoder: Each tone is converted into a number which is stored on the board. **PH-145: \$87**

A-BUS Prototyping card: 4x4.5" card. Will accept up to 10 I.C.s. With power & ground bus. **PR-152: \$16**

Counter Timer: Three 16 bit counters/timers. Use separately or cascade for long (48 bit) counts. **CT-150: \$132**

Call our application engineers to discuss your project.

Motion Control

Smart Quad Stepper Controller: The world's finest. On board microprocessor controls four motors simultaneously. Uses simple English commands like "MOVE ARM 10.2 (INCHES) LEFT". For each axis, you control coordinates (absolute or relative), ramping, speed, units, scale factors, etc. Many inputs for limit switches, etc. On the fly reporting of speed, position... Built in drivers for small motors (such as MO-103 or 105). **SC-149: \$299**
Options: ▶ 5 amp/phase power booster for 1 motor: **PD-123: \$49**
▶ Remote "teach" keypad for direct motor control: **RC-121: \$54**

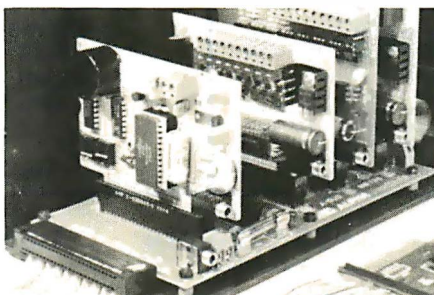

A large A-BUS system with two Motherboards Adapter in the foreground plugs into PC.XT.AT type slot.

Stepper Driver Kit: For experimenting with stepper motors. Includes 2 MO-103 motors and a ST-143 dual driver **PA-181: \$99**

Stepper Motors: (4 phase, unipolar)
MO-103: 2 1/4" dia. 1/4" shaft. 7.5"/step. 12V. 5 oz-in torque. **\$15**
MO-104: 2" dia. 1/4" shaft. 1.8"/step. 5V. 60 oz-in torque. **\$45**
MO-105: 1.7" square. .2" shaft. 3.75"/step. 12V. 6 oz-in. **\$15**

A-BUS Adapters

▶ Can address 64 ports and control up to 25 A-BUS cards.
▶ Require one cable. Motherboard required for more than 2 cards.

A-BUS Parallel Adapters for:

IBM PC/XT/AT & compatibles. Uses one short or long slot. **AR-133: \$69**
Apple II, II+, IIe Plugs into any slot inside. **AR-134: \$52**
Commodore 64, 128 Plugs into Expansion Port on back. **AR-139: \$48**
TRS-80 Model 102, 200 Uses 40 pin "System bus". **AR-136: \$76**
Model 100 (Tandy portable) Plugs into socket on bottom. **AR-135: \$75**
TRS-80 Model 3, 4, 4D Y-Cable available if 50 pin bus is used. **AR-132: \$54**
TRS-80 Model I Plugs into 40 pin expansion bus. **AR-131: \$39**
Tandy Color Computers Fits ROM slot. Multipak or Y-Cable **AR-138: \$49**

A-BUS Cable: Necessary to connect any parallel adapter to one A-BUS card or to first motherboard. 50 pin, 3 ft. **CA-163: \$24**
Special Cable for two A-BUS cards **CA-162: \$34**

Serial Adapter: Connect A-BUS systems to any RS-232 port. Allows up to 500 ft from computer to A-BUS. **SA-129: \$149**

Serial Node: To connect additional SA-129/A-BUS systems to a single RS232 serial port (max 16 nodes). **SN-128: \$49**

Serial Processor: same as above plus built in BASIC for off-line monitoring, logging, decision making, etc. **SP-127: \$189**
Use SA-129 or SP-127 with modems for remote data acquisition.

Motherboard: Holds up to 5 A-BUS cards in sturdy aluminum frame with card guides. A sixth connector allows (using cables CA-161: \$12) additional Motherboards to be added. **MB-120: \$108**

Power Supply: Power pack for up to 4 cards. **PS-126: \$12**

Complete Catalog Available

For Orders and Info call (203) 656-1806

Weekdays from 9 to 5 EST or FAX 203 656-0756

Ordering Information: We accept Visa, Mastercard, Checks, and M.O. C.O.D. is \$4 extra. Purchase orders are subject to credit approval. CT residents add 7.5% sales tax. Shipping: \$4 per order (usually UPS ground), UPS 2nd Day Air: \$4 extra. Next Day service available. Canada: \$6 per order (Airmail). Outside US and Canada: Add 10% of order total.

Circle 16 on Reader Service Card



ALPHA Products

242-B West Avenue, Darien, CT 06820

MAY 1989 • BYTE 327

YOU'LL
GO...APE!

**FEDERAL EXPRESS
SECOND DAY AIR!**
Ask Us About Special
Low, Low Rates!!!

Panasonic
Office Automation **OA**



KX-P1595
\$439

**2 YEAR
WARRANTY**

- KX-P1180 \$179
- KX-P1191 \$249
- KX-P1592 \$429
- KX-P1595 \$439
- KX-P1524 \$539
- KX-P4450 \$1395
- KX-P1124 \$329

FX-RS505
Image Scanner

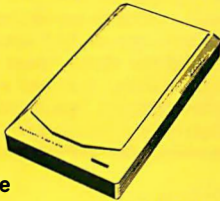

**Fax Partner
FX-BM89
Fax
Board
\$599**
(List \$995)

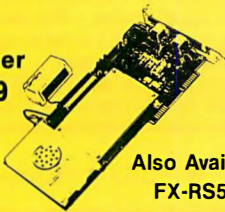

Also Available
FX-RS506

- Faster
 - Higher Resolution (List \$1899)
- \$1195**

With Interface
and Cable
(List \$1499)

SPECIAL OFFER



Laser Partner™
KX-P4450

\$1395 (List \$2595)

- Two 250-sheet paper cassettes
- 300 dot-per-inch resolution
- Five popular printer emulations
- Standard parallel and RS-232 serial interfaces
- Convenient front panel controls
- 512K RAM standard

Panasonic - Panafax
**THE LITTLE
BIG FAX.**



PANAFAX UF-250

IN STOCK NOW FOR SAVINGS!!

- UF-150 \$1075
- UF-250 \$1395
- UF-260 \$1850

**H-P COMPATIBLE FONTS
AND
MEMORY**

- **NEW! NEW! Plotter In A Font** \$249
- **The All In One 25 In 1 Font** \$268
- **For Lotus, Slik Spreadsheet Font Special** \$110
- **Upgradable Memory Boards**
 - 1MB** \$274
 - 2MB** \$544
 - 4MB** \$944

PACIFIC DATA PRODUCTS



APPLIED • PROGRESSIVE • ELECTRONICS • INC.

203 Southwest Cutoff Route 20, Northboro, MA 01532
FAX (508) 393-3124 • Local (508) 393-7220

1-800-272-9276
(NATIONAL)

(508) 393-7220

1-800-332-0342
(VERMONT)

(802) 334-5801

1-800-344-5648
(CANADA)

1-800-553-1176
(MASSACHUSETTS)

HOURS: 9AM-8PM MON-FRI EASTERN STANDARD TIME

We Accept At No Additional Charge



American Express Also Accepted

Expires 5/31/89

ALL ITEMS OFFERED WHILE STOCK LASTS
Ordering information: We ship anywhere in the continental United States via UPS. Prices are subject to change without notice. We accept VISA, MasterCard, personal company checks and money orders subject to prior approval.

All returns must have prior authorization from our customer service department within 7 days of receipt. All returns must be in like-new condition, complete and in original packaging. Incomplete merchandise will not be accepted for return. All returns for merchandise credit only.

Defective products will be repaired or replaced at APE's discretion. We do not guarantee compatibility. Not responsible for typographical errors.

YOU'LL

GO...APE!

BE SURE TO ASK US ABOUT



**HEWLETT
PACKARD
ACCESSORIES**

EPSON®



LX-800
Dot-Matrix Printer

- Full-featured, 80-column printer
- 180 CPS draft mode; 30 CPS NLQ
- Automatic single sheet loading
- SelectType front control panel
- Compatible with most computers
- One year limited warranty

NOW ONLY \$179

The LQ-500 combines the advantages of 24 pin Letter Quality printing with the benefits of affordable performance. With Epson's exclusive SelectType front control panel, the LQ-500 gives you push-button control of an array of impressive features. The LQ-500 also comes equipped with a pull tractor and friction feed with single-sheet auto load, which allow you to utilize a wide variety of paper.

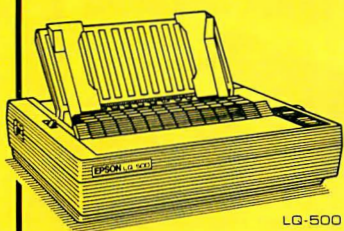

LQ-500

NOW ONLY \$289

The LQ-850 combines SmartPark™ paper handling with 24-pin Letter Quality printing excellence. With SmartPark, you can quickly switch paper types without removing hardware or paper. And the LQ-850's SelectType front control panel gives you push-button control of an array of impressive features. For word processing and general office correspondence, this narrow-carriage printer is ideal.

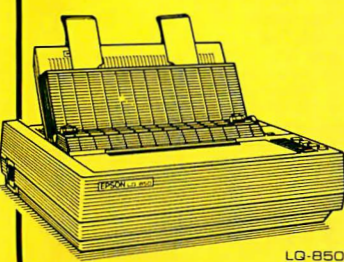

LQ-850

CALL \$\$\$\$\$\$

Dramatic Savings On All Other Epson Printers

EX 800, FX 850 & 1050, LQ 850, 1050 & 2550

ALL EPSON RIBBONS 3 for 2

Ask About Great Printing On All EPSON Products

ALL PRODUCTS IN STOCK

SHARP®

FROM SHARP MINDS COME SHARP PRODUCTS™

- 10 MHz High Speed 80286 CPU (6/8 MHz switchable)
- Illuminated Supertwist Crystal Display with 4 gray scale levels
- Dual high density floppies (PC-7202) or single floppy and 20MB hard disk drive (PC-7221)
- 120 key detachable keyboard with separate numeric and cursor keypads
- 640 KB of RAM, expandable to 1.6 MB on the system board
- One internal expansion slot for full-size PC and AT compatible expansion cards
- Parallel, serial, and color/monochrome CRT ports
- One internal expansion slot for full-size PC and AT compatible expansion cards
- Optional internal modem card and expansion unit with four card slots

MODEL PC-7200 SERIES
The power of a desk-top AT in a compact portable unit



PC-7200

PC-7221 \$1495 PC-7241 \$2195

Battery Powered LAPTOPS from SHARP®

- High contrast, illuminated supertwist display
- 20 MB hard disk drive and single 3.5 inch floppy drive
- High speed processor (7.16 MHz)
- 640K RAM
- Full-sized keyboard with 10 key numeric pad
- Software compatible with IBM PC
- Optional 300/1200 baud modem, CRT adapter, 1 MB EMS card, 768K EPROM card
- Also available with dual 3.5 inch floppy disk drives (Model PC-4502)

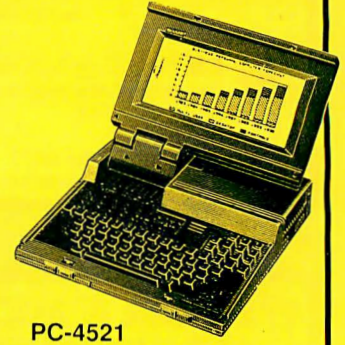

PC-4521

PC-4502 \$895
PC-4502M \$1095
PC-4521 \$1695
PC 4521M \$1895

NEW PC-4600 SERIES.....CALL



APPLIED • PROGRESSIVE • ELECTRONICS • INC.

203 Southwest Cutoff Route 20, Northboro, MA 01532
FAX (508) 393-3124 • Local (508) 393-7220

1-800-272-9276
(NATIONAL)

(508) 393-7220

1-800-332-0342
(VERMONT)

(802) 334-5801

1-800-344-5648
(CANADA)

1-800-553-1176
(MASSACHUSETTS)

HOURS: 9AM-8PM MON-FRI EASTERN STANDARD TIME

We Accept At No Additional Charge



American Express Also Accepted

Expires 5/31/89

ALL ITEMS OFFERED WHILE STOCK LASTS
Ordering information. We ship anywhere in the continental United States via UPS. Prices are subject to change without notice. We accept VISA, MasterCard, personal, company checks and money orders subject to prior approval.

All returns must have prior authorization from our customer service department within 7 days of receipt. All returns must be in like-new condition, complete and in original packaging. Incomplete merchandise will not be accepted for return. All returns for merchandise credit only.

Defective products will be repaired or replaced at APE's discretion. We do not guarantee compatibility. Not responsible for typographical errors.

EZ-ROUTE VERSION II

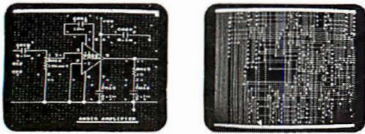

SCHEMATIC TO PCLAYOUT \$500 INCLUDES AUTO ROUTER

EZ-ROUTE Version II from AMS for IBM PC, PS/2 and Compatibles is an integrated CAE System which supports 256 layers, trace width from 0.001 inch to 0.255 inch, flexible grid, SMD components and outputs on Penplotters as well as Photo plotters and printers.

Schematic Capture \$100, PCB Layout \$250, Auto Router \$250.

FREE EVALUATION PACKAGE

30 DAYS MONEY BACK GUARANTEE

1-800-972-3733 or (305) 975-9515

ADVANCED MICROCOMPUTER SYSTEMS, INC.
1321 N.W. 65 Place - Ft. Lauderdale, FL 33309

LAN-MARK

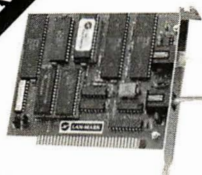

THE MOST AFFORDABLE AND RELIABLE NETWORK

- Connects up to 64 PCs, ATs, and PS/2/30s.
- Saves you enough time to worth your money.
- High speed hardware controlled network, 25 times faster than software links.
- Snap installation, just plug and go.
- No tweaking or adjustments needed.
- Absolutely, positively guaranteed. Try it for 30 days. Full money back if you are not 100% satisfied.

Only \$199 per station. 3-Station Pak: \$549.

LAN-MARK Systems, an Advin Company
1050L East Duane, Sunnyvale, CA 94086
(408) 243-7000 • Fax (408) 736-2503

DATA CONVERSION SYSTEMS

9-Track Tape for your PC, AT, PS/2, MAC, Sun

Read/write data from nearly any Mainframe: IBM, DEC, HP, DG, or Honeywell. Runs under MS-DOS, Unix, Xenix, MAC, and SunOS.

8", 5 1/4", 3 1/2" Diskette converter for your PC/XT/AT

Our diskette conversion system can read/write and format diskettes from IBM Systems 34, 36, 38, AS400, DEC, CMX, CP/M, Displaywriter and many more.



1-800-223-3693

In California call:
1-415-324-9114

525 Alma, Palo Alto, CA 94301

Circle 21 on Reader Service Card

Circle 151 on Reader Service Card

Circle 179 on Reader Service Card

SEAGATE ADD-ON CARDS

| | |
|---------------------------|-----------------------------|
| ST-225 with c/c.....\$245 | Color Graphic.....\$ 37 |
| ST-238 with c/c.....\$265 | Monographic.....\$ 38 |
| ST-251.....\$320 | Multi I/O XT.....\$ 38 |
| ST-251-1.....\$405 | Multi I/O AT.....\$ 35 |
| ST-4096.....\$545 | Hard Floppy Contr.....\$115 |

MOTHER BOARDS DRIVES

| | |
|---------------------------------|---------------------------|
| TMB 10MHz XT.....\$ 62 | Fujitsu 360K.....\$ 60 |
| TMB BABY AT 6/10 MHz.....\$ 230 | Fujitsu 12.....\$ 80 |
| AT 6/10 MHz.....\$ 235 | Floppy 35" 720K.....\$ 80 |
| AT 6/12 MHz.....\$ 310 | Floppy 144 Mb.....\$115 |
| AT 386 20 MHz.....\$1320 | |
| AT 386 25 MHz.....\$1380 | |

ALL PRODUCTS ARE 100%
IBM COMPATIBLE.

KEYBOARDS

KB 101.....\$45

WE HAVE POWER SUPPLIES
AND MUCH MORE.



A.N. Wholesale & Retail, Inc.
1320 South Dixie Hwy. Suite 256
Miami, Fla 33146

Phone: (305) 284-0827

Fax: (305) 284-0831

Circle 33 on Reader Service Card

BUY QUALITY FOR LESS! MAXELL

5 1/4" DS/DD 59¢
3 1/2" DS/DD 1.09
LIFETIME WARRANTY

Price based on quantity of 300 in bulk
includes Tyvek sleeves and label kits.

800-222-0490

In NJ 201-462-7628

FAX 201-462-5658

• 24 Hour Shipment •

MEGAsoft

P.O. Box 710, Freehold, NJ 07728

Circle 173 on Reader Service Card

VIDEO FRAME GRABBERS

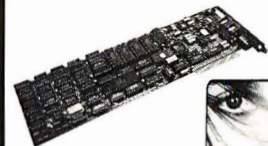

| MODEL | RESOLUTION | |
|------------|----------------|------|
| HRT 256-4 | 256 x 256 x 4 | 495 |
| HRT 256-8 | 256 x 256 x 8 | 795 |
| HRT 512-8 | 512 x 512 x 8 | 995 |
| HRT 512-24 | 512 x 512 x 24 | 1995 |

- IBM PC/XT/AT COMPATIBLE
- DIGITALIZE IN REAL TIME
- COMPOSITE VIDEO IN
- 24 BIT RGB OUT except model HRT 256-4
16 level gray scale out
- SOFTWARE LIBRARY OF IMAGE ANALYSIS ROUTINES
- FREE SOFTWARE UPGRADES TO REGISTERED OWNERS
- FULL CREDIT ON UPGRADE PURCHASE IN FIRST YEAR
RETURN OLD BOARD AND JUST PAY DIFFERENCE



HRT

HIGH RES TECHNOLOGIES
P.O. BOX 76
LEWISTON, N.Y. 14092

PHONE 416-497-6493

FAX 416-497-1988

Circle 127 on Reader Service Card

E/EPROM & MICRO PROGRAMMER

\$895



- EP-1140 includes: software, cable, user's manual, 2 free software update coupons, toll-free technical support, one-year warranty & a unconditional 30-day money back guarantee
- Programs 24-, 28-, 32- & 40-pin E/EPROMs
- Supports 874X & 875X series microcontrollers
- Connects to a standard parallel port
- 32-pin model, EP-1132, available for \$695

The Engineer's Programmer™

CALL TODAY 800-225-2102

BP MICROSYSTEMS

10681 Haddington, #190, Houston, TX 77043
713/461-9430 FAX 713/461-7413

Circle 34 on Reader Service Card

ICs PROMPT DELIVERY!!!

SAME DAY SHIPPING (USUALLY)

QUANTITY ONE PRICES SHOWN for MARCH 26, 1989

OUTSIDE OKLAHOMA: NO SALES TAX

| DYNAMIC RAM | | |
|------------------|--------|----------|
| SIMM (1) 256Kx36 | 80 ns | \$460.00 |
| SIMM 1Mx9 | 80 ns | 295.00 |
| SIMM (2) 1Mx9 | 85 ns | 225.00 |
| SIMM 256Kx1 | 60 ns | 125.00 |
| 1Mbit 1Mx1 | 100 ns | 20.95 |
| 41256 256Kx1 | 60 ns | 11.25 |
| 41256 256Kx1 | 80 ns | 10.85 |
| 41256 256Kx1 | 100 ns | 8.95 |
| 51258 (3) 256Kx1 | 100 ns | 10.50 |
| 41256 256Kx1 | 120 ns | 8.25 |
| 41264 (4) 64Kx4 | 120 ns | 14.50 |
| EPROM | | |
| 27C1000 128Kx8 | 200 ns | \$28.50 |
| 27C512 64Kx8 | 200 ns | 13.95 |
| 27256 32Kx8 | 150 ns | 8.15 |
| 27128 16Kx8 | 250 ns | 4.75 |
| STATIC RAM | | |
| 62256P-10 32Kx8 | 100 ns | \$23.50 |
| 6264P-12 8Kx8 | 120 ns | 9.50 |
| 6116AP-12 2Kx8 | 120 ns | 5.50 |

OPEN 6 1/2 DAYS, 7:30 AM-10 PM; SHIP VIA FED-EX ON SAT.

SAT DELIVERY INCLUDED ON FED-EX ORDERS RECEIVED BY THE 9:00 AM FR. \$12.25 IN

MasterCard/VISA or UPS CASH COD MICROPROCESSORS UNLIMITED, INC. 24,000 S. Peoria Ave. (918) 267-4961 BEGGS, OK. 74421 No minimum order. Please note: prices subject to change! Shipping, insurance extra, up to \$1 for packing materials.

Circle 177 on Reader Service Card

a complete 80386 system for only

\$1995

- ☞ 1 meg ram
- ☞ 40 meg. hard drive
- ☞ TTL mono. monitor
- ☞ Parallel & Serial Ports
- ☞ Expand to 16 meg.
- ☞ 1 year warranty
- ☞ 30 day moneyback

Call for other systems and configurations at similar savings.

Scioto Computers

1-800-283-8616

Circle 41 on Reader Service Card



WE WILL MATCH OR BEAT ANY ADVERTISED PRICE



CALL TOLL FREE 800/888-9294



only \$329.00

THE VECTOR XT TURBO

4.77 to 10 MHz • 256 to 640k
150 Power Supply • AT Style Keyboard
1 Drive with cont. • AT Case Turbo Switch
1 20 Meg Seagate St 388

\$549

with Monochrome **\$669** with Color **\$769**

THE VECTOR (286-10)

80286 • 640k • Up to 1 Meg • 1.2 Meg
Floppy AT KB • Floppy and Hard Controller
200 Watt Power Supply

\$849

with 30 Meg with Monochrome **\$1349** with 30 Meg with Color **\$1449**

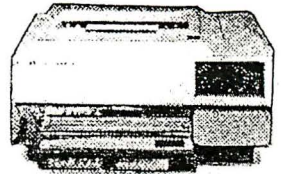

hp HEWLETT PACKARD

LAZER JET \$1585
Desk Jet \$699.00

HARDWARE SPECIALS

- PARADISE VGA CARD **\$235**
- PACKARD BELLS MONO MONITOR **\$72**
- PANASONIC 1124..... **\$319**
- PGS ULTRASYNIC MONITOR **\$479**

QUANTITY BREAKS ON ALL SPECIALS!!!

XT CASE



Two Bay Standard XT Style Case
Keylock Power and Hard Drive LED's
L.A.C.C. Price \$22

THE VECTOR XT TURBO
4.77 to 10 MHz 256 to 640k
150 Power Supply AT Style Keyboard
1 drive w/cont. AT Case Turbo Switch



- Seagate 20 ST-225 \$239
- Seagate 30 ST-238 \$249
- Seagate 40 ST-251-1 \$395
- Seagate 80 ST-4096 \$639

MONITORS

- Samsung 1252 Amber 12" Tilt & Swivel \$75
- Samsung 1257 Amber 12" 720 x 350 \$39
- Samsung 1464 RGB 640 x 200 Color \$230
- Samsung 1453 EGA 720 X 480 64 Color \$339
- PGS Ultrasync VGA Monitor 479
- NEC Multisync II Monitor \$575
- Packard Bell Monitor Call
- Taxan Demos Call
- Relysis Call
- Sony 1302 + 303 Call

UTILITIES

- I DIR Plus \$46
- Brooklyn Bridge \$69
- Carousel 2.0 \$43
- Copy II PC \$20
- Copywrite \$40
- Corefast \$89
- Cruise Control \$29
- Direct Access \$48
- Disk Optimizer 2.0 \$39
- Disk Technician Plus \$66
- DS Back-up Plus \$46
- Fastback \$75
- Fastback Plus \$99
- Keyworks \$53
- Laplank \$72
- Mace Utilities \$51
- Microsoft Windows 286 \$59
- Microsoft Window 386 \$109
- Norton Commander \$43
- Norton Editor \$37
- Norton Utilities 4.0 \$49
- PC Tools Deluxe \$39
- Printworks for Dot Matrix 43
- Printworks for Laser \$67
- Sidekick Plus \$115
- Sideways \$37
- Smart Notes \$43
- Sidekick 15 \$50
- Superkey \$58
- Unlock D Plus \$49
- Unlock Masterkey \$95
- XTree \$35
- XTree Professional \$61

MONEY MANAGEMENT

- Dollars & Sense w/Forecast \$105
- Tobias Managing your Money 4.0 \$114

ACCOUNTING

- ACCPAC Easy \$229
- Bedford Accounting \$139
- DAC Easy Payroll \$53
- DAC Easy Payroll \$53
- One Write Plus 2.0 \$117
- Time Slips \$69
- ACCPAC BPI \$229
- DAC Easy Accounting \$53
- In-House Accountant \$105
- One Write A/R, A/P Payroll \$117
- Time Slips III \$109



LOGI TECH
DEXXAMOUSE
SERIAL **\$45**

PANASONIC 1124

\$319

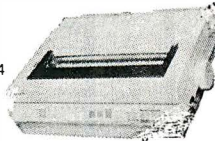

ACCESSORIES

- 150W Power Supply \$49
- 200W Power Supply \$55
- LACC Modem 1200B w/Software \$69

AST PREMIUM/286

- PC MAGAZINE ED'S CHOICE
- Model 80 Call
- Model 140 \$2399
- Model 120 \$2150
- Model 170 \$2750

IBM PRICES TO LOW TO LIST

- Model 30 Call
- Model 50 • 20 Meg Call
- Model 60 • 44 Meg Call
- Model 80 • 44 Meg Call

MONITOR INTERFACES

- LACC Fabulous Mono Hercules
Compatible or Color Card \$49.95
- Hercules Mono/Here Color \$289/\$299

COMPAQ

- Desk Pro 286 • 12 Mhz • 40 Meg Call
- Portable II Model 2/4 Call
- Portable 386 • 40 Meg Call

TOSHIBA LAPTOP

- Model 1000 \$750
 - Model 1200/1200F \$2250/\$1395
 - Model 3100 \$2995
 - Model 3200/5100 \$3495/\$4495
- Also available from LACC (Apple, Compaq, Dell, etc.)
Epson MC Equity LT • MS Dos 3.2.2 • Floppy, 20 MEG 640k
4.77/10 MHz • EDT CALL

SOFTWARE SPECIALS

- Wordstar Professional 5.0 \$209
- Fastrax 5 1/2" 3 1/2" \$40
- Word Perfect 5.0 \$219
- Word Star 2000 to Low to List Call

PROJECT MANAGEMENT

- Harvard Total Project Manager II \$309
- Timeline 3.0 \$315
- Microsoft Project 4.0 \$299
- Superproject Expert \$399
- Quick Basic 4.5 \$65
- Quick CV 2 \$65
- Ryan McFarlan Fortran \$379
- Turbo Basic \$58
- Turbo CV 2 \$85
- Turbo Pascal 5.0 \$85
- Turbo Pascal Dev. Library \$228
- Turbo Prolog V.2 \$89
- Newsmaker II \$39
- Pagemaker 30 \$489
- PFS: First Publisher \$65
- Ventura Publishing \$475

DESKTOP PUBLISHING

PANASONIC

- Panasonic 10801140cps 80 col \$189
- Panasonic 1081 \$199
- Panasonic 1091 \$169
- Panasonic 1092 \$319
- Panasonic 1124 \$325
- Panasonic 152KXP \$529
- Panasonic 1592KXP \$399
- Panasonic 1595KXP \$429
- Panasonic 3131 \$269
- Panasonic 3151 \$439

- Epson FX1050 264 cps, 54nlg 9 pin \$469
- Epson FX286 E 240 cps, 40nlg \$339
- Epson FX850 264 cps, 54 NLO 9pn \$699
- Epson LQ1050 330 cps, 88 nlg 24 pn \$929
- Epson LQ2550 400 cps, 133 nlg 24 p \$299
- Epson LQ500 180 cps, 60 nlg 24 pin \$519
- Epson LQ850 330 cps, 88 nlg 24 pin \$185
- Epson LX800 180 cps, 30 nlg 9 pin \$185

DATA BASE MANAGEMENT

- Paradox 2.0 \$415
- PFS: Professional File \$119
- Q&A 3.0 \$185
- Q&A Write \$105
- R Base For Dos \$420
- Reflex \$88
- VP Expert \$112
- Clipper \$409
- dBase \$449
- DB-XL Diamond \$107
- Eureka \$99
- Genifer \$168
- Nutshell \$75
- Nutshell Plus \$142
- Easy Extra \$50
- Grandview \$159
- MultMate Advantage II \$259
- PFS: Professional Write \$102
- Walkwriter 3 \$195
- Walkwriter Deluxe Plus \$55.7
- Webster New World \$53
- Prof. Spell Checker \$32
- New World Thesaurus \$199
- Word (Microsoft S.d.) \$289
- R Base 5000 4.2 \$219
- Word Perfect Executive \$115
- Word Perfect Library \$59
- WordStar Pro Pack 5.0 Call
- WordStar 2000 Plus 3.0 Call

INTEGRATIVE SOFTWARE

- MS Works V 1.05 \$89
- PFS 1st Choice \$85
- Smart Software System \$389
- Symphony \$435
- Ability Plus \$137
- Enable 2.0 \$352
- Framework III \$425
- MS Basic Compiler \$165
- C Compiler (Microsoft) \$265
- Cabal Compiler \$512
- MS Fortran Compiler 4.0 \$265
- Latice C Compiler \$215
- Macro Assembler \$85
- Pascal Compiler (Microsoft) \$176



LOS ANGELES COMPONENTS & COMPUTERS

A California Corporation
2701 Plaza Del Amo, Torrance, CA 90503

Mon-Fri 8:00-6:00
Saturday 10:00-2:00
Customer Service
Mon-Fri 10:00-4:00

Outside CA 800-888-9294
Inside CA 213-328-9294
FAX # 213-328-1758

SHIPPING
UPS, US Mail
Federal Express
Emery & Other

PO's accepted from qualified companies, institutes and schools.

We Accept: COD Wire Transfers



**9-TRACK MAG. TAPE SUBSYSTEM
FOR THE IBM PC/XT/AT AND...**

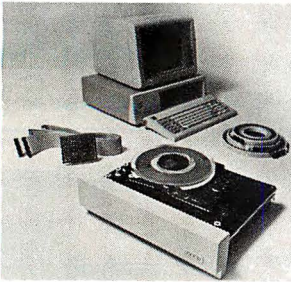

For information interchange, backup and archival storage, AK Systems offers a 9-track, IBM format-compatible 1/2" magnetic tape subsystem for the IBM PC, featuring:

- IBM format 1600/3200 and 800 cpi.
- Software for PC-DOS, MS-DOS, XENIX.
- Also for AT&T, DEC, VAX, VME, S-100, RS-232, IEEE488.

Starting at \$2595.00

AKSystems

2074a Marilla St.
Chatsworth, CA 91311
(818) 709-8100
TWX: 910-493-2071

Write, phone or TWX for information.

Circle 15 on Reader Service Card

MODEM 2400

2400 BAUD MODEM PLUS PHONE

NEW & UNIQUE Specifications:

- ▼ Compatibility: CCITT V.22 bis, V.21, V.22 and G.1622/103
- ▼ Speed conversion: 2400/1200/300bps
- ▼ Data throughput: 2400 bps
- ▼ Dynamic fall back and fall forward
- ▼ Line equalization: equalization for transmitter and adaptive equalizer
- ▼ Software compatibility
- ▼ Front panel indicator
- ▼ Dial-up & leased line operation
- ▼ One year warranty



**DEALER / OEM / DISTRIBUTOR
INQUIRIES WELCOME**



E-TECH RESEARCH, INC.

2700 Augustine Dr. #275 Santa Clara, CA 95054

(408) 982-0270

Fax: 982-0272

Circle 104 on Reader Service Card

DELTA COMPUTING

SIMMS

| | | |
|----------|--------|-----------|
| 1MB x 9 | 80 ns | \$ 299.00 |
| 1MB x 9 | 100 ns | 279.00 |
| 256K x 9 | 80 ns | 109.00 |
| 256K x 9 | 100 ns | 99.00 |

DYNAMIC RAM

| | | |
|-------|--------|----------|
| 41256 | 80 ns | \$ 13.95 |
| 41256 | 100 ns | 12.95 |
| 41256 | 120 ns | 11.95 |
| 41464 | 80 ns | 12.95 |
| 41464 | 100 ns | 10.95 |

VISA **800-227-4051** M/C

MISC.

| | | |
|-------|-------|-----|
| 27128 | 8087 | V20 |
| 27256 | 80287 | V30 |
| 27512 | 80387 | |

CALL FOR CURRENT PRICES

DELTA COMPUTING TECH. CORP.

292 North Plank Rd.
Newburgh, NY 12550
PH# 814-565-7080
FAX 814-565-7082

Via L. Landucci No 26
50136 Florence Italy
PH# 39 55 676 045
FAX 39 55 688 942

Circle 311 on Reader Service Card



**System 1800
Basic System \$899
(MADE IN U.S.A.)**

- Intel 80286 CPU
- Fully compatible with IBM AT
- 6.8 MHz selectable, 8 slots
- 512K on 1M. mod. r. board
- 195 watt power supply 100/220
- Clock/Cache, Everex HD/FDCont
- FCC class "B" approved
- 48 Hour factory/high temp. dynamic burn-in
- 1.2 MEG track Dr. AT Keyboard
- Runs AutoCAD, Lotus, Xenix, Novell, all prop. Software
- 200 pages of documentation (written in U.S.A.)
- 80287 CD Processor socket
- 80,000 units installed with customer reputation file
- Made in U.S.A.
- with 1 year warranty

| | |
|--|---------------|
| Mono Sys (Basic Sys + EverexGraphics 132 col. w/ep. 14" Everex Flat Mon.) | Special \$995 |
| EGA Sys (Basic Sys + EverexEGA card + 14" Everex EGA (31mm) Mon.) | \$1414 |
| Super EGA Sys (Basic Sys + Everex EGA card + NEC Ultra80 8060 (31mm) Mon.) | \$1700 |
| System 1800 10MHz 286 0 w/1 312K 25. P. KB. Base system | \$1099 |
| System 1700 12MHz 286 0 w/1 1 meg RAM, KB. Base system | \$1295 |
| System 3000 15MHz 386 0 w/1 1 meg, KB. Base system | \$1995 |
| System 3000D 20MHz 386 0 w/1 1 meg, KB. Base system | \$2700 |

Full Line of Everex Products Available

| | | | |
|----------|-----------------|--------------|--------|
| NEW | +64K | 386 20/0 1m | \$2295 |
| LD | +1.2m Dr | 386 5/0 1m | \$2195 |
| PORTABLE | +640x200 | 286 5/0 312K | \$1629 |
| | + Super Fast LD | 286-12/0 | \$1395 |
| | + Back Lite | | |

Schwab Computer Center
"The Everex Store" - Authorized Everex Corp. VAR
3282 El Camino Real, Santa Clara, CA 95051
408-241-1210 Fax # 408-241-1279

Daily UPS M-F 8-7; SAT 11-4 Prices change without notice VISA/MC/AE

Circle 243 on Reader Service Card

Advertise your computer products through **BYTE BITS** (2" x 3" ads)

For more information call Mark Stone at **603-924-6830**

BYTE
One Phoenix Mill Lane
Peterborough, NH 03458

Circle 310 on Reader Service Card

Add-Ons for the Blind

What you add on to your computer, if you're a blind operator, is almost more important than the computer itself.

Scanners, modems, braille printers, speech synthesizers, braille output devices and a host of other peripherals are described in "Add-Ons: The Ultimate Guide to Peripherals for the Blind Computer User."

The product reviews contained in this book are written by those who know them best—blind computer users.

\$16.95 for braille or cassette
\$19.95 for print.

Send orders to:

National Braille Press Inc.
88 St. Stephen Street, Boston, MA 02115
(617) 266-6160

NBP is a nonprofit braille printing and publishing house.

Back, by popular demand.

Just a few years ago, illegal hunting and encroaching civilization had all but destroyed the alligator population in the south. They were added to the official list of endangered species in the United States.

Now alligators have made a comeback.

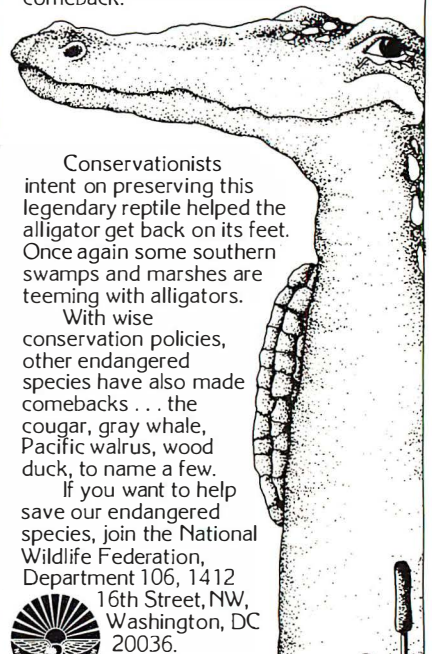

Conservationists intent on preserving this legendary reptile helped the alligator get back on its feet. Once again some southern swamps and marshes are teeming with alligators.

With wise conservation policies, other endangered species have also made comebacks... the cougar, gray whale, Pacific walrus, wood duck, to name a few.

If you want to help save our endangered species, join the National Wildlife Federation, Department 106, 1412 16th Street, NW, Washington, DC 20036.



CAT™ 10MHZ

BASE SYSTEM

- 256K (Opt. 640K) • 150 Watt Power Supply • AT Style Keyboard & Case
- 4.77 or 8 MHz Keyboard Selectable • FDC
- 8087 Socket • 360K Floppy Drive • 1 Year Warranty

\$369⁰⁰

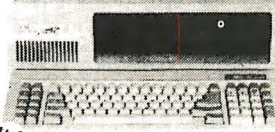

CAT 386 SYSTEM

- 12" Amber Monitor with Graphics Interface Card
- 1.2 Meg Floppy Drive (expandable to 8 Meg)
- 1 Meg of Memory
- Parallel, Serial & Clock
- 70 Meg Hard Drive

20MHz **\$2297⁰⁰**

CAT™ 286-10MHZ

BASE SYSTEM

- 512K Exp. to 1 MEG • 200 Watt Power Supply • AT Style Keyboard
- Western Digital Controller • 1.2 Meg Floppy • Legal Bios w/manuals • Systems Documentation • 1 yr war. • Clock/Calc
- 10MHz DTK Motherboard

\$749⁰⁰

11.3 NORTONS SL

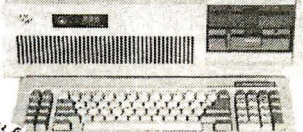

8088 XT Compatible

| | |
|-------------------------------|-------------------|
| 640 K Upgrade | 139 ⁰⁰ |
| 12" Amber Monitor w/Interface | 139 ⁰⁰ |
| DOS 4.01 w/GWV BASIC | 89 ⁰⁰ |

| | |
|-------------------------|------------------|
| Clock Calendar | 24 ⁰⁰ |
| Parallel & Serial Ports | 39 ⁰⁰ |
| Additional Drives | See Below |

SYSTEM OPTIONS

286, 386 AT Compatible

| | | | |
|-------------------------------|-------------------|---|-------------------|
| 640 K Upgrade | 59 ⁰⁰ | 14" EGA Monitor w/Interface | 549 ⁰⁰ |
| 1 Meg Upgrade | 189 ⁰⁰ | Novell Network • Call 12 Mhz add100 ⁰⁰ | |
| 12" Amber Monitor w/Interface | 139 ⁰⁰ | 14" Color Monitor w/Interface | 289 ⁰⁰ |

WE WILL NOT BE UNDERSOLD ON:
SEAGATE EVEREX INTEL WESTERN DIGITAL SAMSUNG ALL RAM UPGRADES
 WE WILL BEAT ALL COMPETITORS QUOTES* CALL (800) 654-7762

intel COPROCESSORS

| If Your PC Uses the Intel | Running at . | Then You Need Intel | MEADS Price |
|---------------------------|---------------|---------------------|-------------------|
| 8088 | 5MHz or less | 8087 | 97 ⁵⁰ |
| 8088 or 8086 | 8MHz or less | 8087-2 | 143 ⁵⁰ |
| 8086 | 10MHz or less | 8087-1 | 209 ⁰⁰ |
| 80286 | 6-8MHz | 80287 | 159 ⁰⁰ |
| 80286 | 8-10MHz | 80287-8 | 229 ⁰⁰ |
| 80286 | 10MHz or more | 80287-10 | 259 ⁰⁰ |
| 80386 | 16MHz | 80387-16 | 379 ⁵⁰ |
| 80386 | 20MHz | 80387-20 | 469 ⁰⁰ |
| 80386 | 25MHz | 80387-25 | 559 ⁰⁰ |
| 386SX | 16MHz | 80387-SX | 399 ⁰⁰ |

RAM UPGRADES

WE BUY EXCESS RAMS PLEASE CALL OR FAX LIST

| 64K | | 1 Meg. | |
|--------|---------------|-------------------|-----------------|
| 4464 | 100 NS, 64x4 | 129 ⁵⁰ | 1Meg x 1 120 NS |
| 4464 | 120 NS, 64x4 | 119 ⁵⁰ | 1Meg x 1 100 NS |
| 4464 | 150 NS, 64x4 | 109 ⁵⁰ | 1Meg x 1 80 NS |
| 4164 | 150 NS, 64x1 | 29 ⁵⁰ | |
| 4164 | 120 NS, 64x1 | 39 ⁵⁰ | |
| 4164 | 100 NS, 64x1 | 34 ⁵⁰ | |
| 256K | | Simm Modules | |
| 41256 | 150 NS, 256x1 | 79 ⁵⁰ | 256 x 8 120 NS |
| 41256 | 120 NS, 256x1 | 89 ⁵⁰ | 256 x 9 80 NS |
| 41256 | 100 NS, 256x1 | 99 ⁵⁰ | 256 x 9 100 NS |
| 41256 | 80 NS, 256x1 | 109 ⁵⁰ | 1Meg x 9 120 NS |
| 414256 | 120 NS, 256x4 | 269 ⁰⁰ | 1Meg x 9 100 NS |
| | | | 1Meg x 9 80 NS |
| | | | 1Meg x 8 120 NS |

We Carry Dips - Zips - Simms - Soj - PLCC - Sipp All Speeds - CALL

Seagate HARD DRIVES

COMPLETE KITS

| | |
|---|-------------------|
| ST125 20Meg 40 Mil 1/2 Ht 3 1/2" Drive only | 279 ⁰⁰ |
| ST138 30Meg 40 Mil 1/2 Ht 3 1/2" Drive only | 339 ⁰⁰ |
| ST225 20Meg w/cont. & Cables | 269 ⁰⁰ |
| ST238 30Meg w/cont. & Cables | 299 ⁰⁰ |
| ST251 40Meg 1/2 HT 40 Mil w/software | 379 ⁰⁰ |
| ST251-1 40Meg, 28 Mil Sec. | 439 ⁰⁰ |
| ST277R 60MB 40 Mil 1/2 Ht | 489 ⁰⁰ |
| ST4026 20Meg Full Ht 40 Mil | 279 ⁰⁰ |
| ST4038 30Meg 40 Mil Full Ht | 309 ⁰⁰ |
| ST4053 40MB 28 Mil Full Ht | 519 ⁰⁰ |
| ST4096 80Meg Full HT w/software | 649 ⁰⁰ |

WESTERN DIGITAL CONTROLLERS

| | |
|---|-------------------|
| WX-1 8 Bit 1/2 Sized for XT | 79 ⁰⁰ |
| WA-2 16 Bit Full Sized Hard/Floppy | 119 ⁰⁰ |
| WD-27X 8 Bit RLL 1/2 Size | 89 ⁰⁰ |
| WAH 16 Bit Hard Drive Controller | 129 ⁰⁰ |
| RA2 16 Bit RLL Hard/Floppy for XT | 159 ⁰⁰ |
| MEAD Floppy Disk Controller for XT, controls 4 drives | 299 ⁰⁰ |
| MEAD 1.2 Meg & 360K Controller for XT | 69 ⁰⁰ |
| Cable Set for Hard Drive Only | 59 ⁰⁰ |

MODEMS BY EVEREX™

| | |
|--|-------------------|
| EV-923 EverCom 12 300/1200 bps Bitcom Software | 69 ⁰⁰ |
| EV-941 EverCom 24 2400 Baud Int. Bitcom Software | 139 ⁰⁰ |
| EV-945 External 2400 Baud | 199 ⁰⁰ |

For error correcting add \$10.00

HAYES COMPATIBLE FROM MEAD

| | |
|---|-------------------|
| 1200 Baud Internal w/Software | 59 ⁰⁰ |
| 1200 Baud External fully Hayes Compatible | 99 ⁰⁰ |
| 2400 Baud Internal 1/2 card w/software | 109 ⁰⁰ |
| 2400 Baud External Fully Hayes Compatible | 129 ⁰⁰ |

SAMSUNG MONITORS

| | |
|---|-------------------|
| 1252 12" Amber w/Tilt & Swivel Base | 79 ⁰⁰ |
| 1257 12" Amber Flat Screen 720 x 350 | 99 ⁰⁰ |
| 1464 14" Color 640 x 200, 16 colors | 239 ⁰⁰ |
| 1453 14" EGA 640 x 350, 64 colors/31 | 369 ⁰⁰ |
| CN4551 EGA 720x480 Multisync Compatible | 419 ⁰⁰ |

EVEREX™ TAPE BACKUPS

| | |
|---|--------------------|
| 40MB Mini Cartridge, 1.8MB/min, XT | 359 ⁰⁰ |
| 40MB Mini Cartridge, 3.6MB/min, AT | 359 ⁰⁰ |
| 40MB Streaming Cassette, 5MB/min w/cont. | 589 ⁰⁰ |
| 60MB Streaming Cassette, 5MB/min w/cont. | 649 ⁰⁰ |
| 60MB Streaming 600A, 5MB/min w/Full cont. | 849 ⁰⁰ |
| 125MB Streaming Cartridge, 5MB/min w/Full cont. | 1119 ⁰⁰ |
| Excell 60 Model 60/80 | 999 ⁰⁰ |
| Excell 125 Model 60/80 | 1269 ⁰⁰ |

External Add 195⁰⁰

★ SPECIALS ★ SPECIALS ★ SPECIALS ★ SPECIALS ★ SPECIALS ★

| | | | | | | |
|------------------------------------|------------------|--|-------------------|--------------------------------|--------------------|-------------------|
| 150 Watt Power Supply | 54 ⁰⁰ | EGA Card 640x350 | 169 ⁰⁰ | 256K Upgrade | 79 ⁰⁰ | GOOD THRU 5-31-89 |
| 200 Watt Power Supply | 79 ⁰⁰ | MonoGraphics w/parallel port, Hercules compatible | 49 ⁰⁰ | 10 Meg Hard drive w/controller | 159 ⁰⁰ | |
| All Direct PC XT or AT Replacement | | ColorGraphics w/parallel port, Hercules compatible | 54 ⁰⁰ | HP LaserJet II | 1749 ⁰⁰ | |

Liquidation Below Dealer Cost — New With Warranties

LETTER QUALITY PRINTER

DAISYWHEEL PRINTER MANUFACTURED BY C.I.TOH

STARWRITER™ F-10

When our 40 cps letter quality daisywheel printer from the same manufacturer is only

\$399⁰⁰ ea.

REPEAT OF A SELLOUT

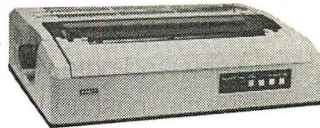

OPTIONS

| | |
|--------------------------------|---------------------|
| • 6 ft. Serial Cable | \$ 19 ⁰⁰ |
| • Bidirectional Tractor | 149 ⁰⁰ |
| • Cut Sheet Feeder | 199 ⁰⁰ |
| • Serial to Parallel Converter | 99 ⁰⁰ |

STANDARD FEATURES

- 40 CPS • Accepts Paper to 15 inches • Form Length and Pitch Set from Control Panel
- Industry compatible ribbon, printwheels and control commands • RS232 Serial Interface

MICROSOFT MOUSE



- In Port with Bus Interface
 - Fully IBM Compatible (of course)
 - Includes Showpartners and Paint Brush
- List \$199 Mead **\$79⁰⁰** 10 for \$740

REPT MONITOR



- FREE TILT SWIVEL BASE
- 14" Flat Screen • Paper White Phosphorus
 - TTL Monochrome & RGB Composite Interface
- List \$199 Mead **\$109⁰⁰** 10 for \$950

STATIC BUSTER

Attached to CRT face and keyboard, Static Buster works just like a sponge, dissipating static at a rated 20,000 volts in less than two seconds.

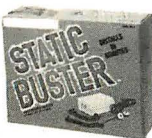

List 49⁰⁰ Mead 19⁰⁰ 10 for \$160

AT STYLE / XT CASE



- 2 Bay Standard AT Style Case
 - Keylock Power and Hard Drive LED's
- List 99⁰⁰ Mead 29⁰⁰ 10 for \$240

TEAC

360K Floppy Drive

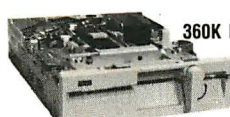

- 360K White Faceplate • 1/2 HT / 55BV
- List 199⁰⁰ Mead 74⁰⁰ 10 for \$690

MINISCRIBE HARD DRIVES

| |
|---|
| MODEL 3053 |
| • 40MB • 28 Mil Sec • 5 1/4 MFM • 1/2 Height |
| List 615 ⁰⁰ Mead 379 ⁰⁰ |
| MODEL 6085 |
| • 72MB • 28 Mil Sec • 5 1/4 MFM • Full Height |
| List 879 ⁰⁰ Mead 529 ⁰⁰ |

800-654-7762

SALES: 7 a.m.-6 p.m. PST

702-294-0204

CUSTOMER SERVICE / ORDER STATUS:

9 a.m.-4 p.m. PST

FAX 702-294-1168

WE ALSO PURCHASE EXCESS INVENTORY— FAX LIST

*Best Quote applies to competitors advertised price with same terms



- Quantity Pricing Available — CALL
- We Accept International Orders
- Purchase Orders from Universities, Government Institutions, Fortune 1000 and Qualified Firms

NO SURCHARGE FOR MC/VISA

TERMS:

- MC • VISA • COD • CASH
- Purchase Orders from Qualified Firms
- Personal Checks • AE add 4%
- 20% Restocking Fee on Non-Defective Returns

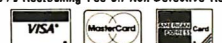

SHIPPING: (min. 6⁰⁰) UPS

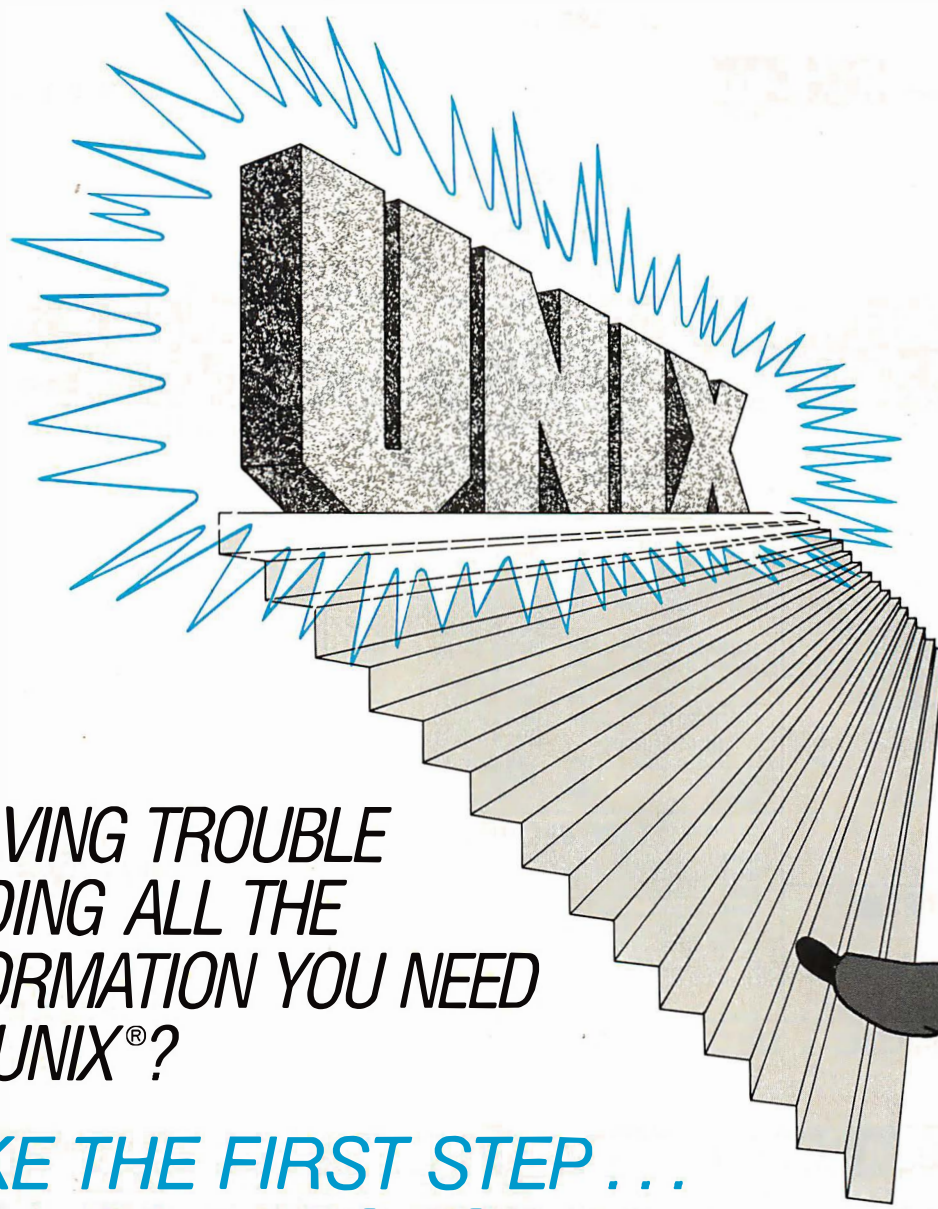

HAVING TROUBLE
FINDING ALL THE
INFORMATION YOU NEED
ON UNIX®?

**TAKE THE FIRST STEP ...
CALL DATAPRO TODAY!**

If you're looking for detailed analysis of the critical issues surrounding UNIX . . . if you need timely information on the products and key players in the industry . . . then turn to Datapro Reports on UNIX Systems & Software.

Updated monthly, this unique new information service is designed to help you discover the opportunities UNIX offers . . . decide how UNIX fits in your organization . . . optimize results while minimizing risk.

Each month, Datapro Reports on UNIX Systems & Software brings you in-depth analyses of every-

thing new and noteworthy in the UNIX market. You receive the most up-to-date, thoroughly researched information available. Information you can put to use in planning your own UNIX strategies.

Find out how much of a difference Datapro can make to your decision-making: call us today at **1-800-DATAPRO** (1-800-328-2776) or use the reader service card.

UNIX® is a registered trademark of AT&T.

datapro®



Complete Kit w/Controller Hard Disk \$148

1200 Baud w/Software Modem \$48

Jade 10 MHz Turbo XT\$398
640K Motherboard w/256K RAM
Floppy Disk Controller
140 Watt Power Supply
101 Enhanced Keyboard

Monochrome Graphics System *698
640K RAM, 360K Disk Drive
Printer Port, Amdek 310A Monitor
30 MB Hard Disk System ... add \$298
CGA Color System add \$188
EGA Color System add \$398
VGA Color System add \$568

Jade 12 MHz Turbo 286\$898
1 MB Motherboard w/512K RAM
200 Watt Power Supply
Clock/Calendar
Enhanced 101 Keyboard

Mono Graphics System\$1098
1.2MB Floppy Drive & Controller
Printer Port, Amdek 310A Monitor
40 MB Hard Disk System ... add \$438
12 MHz, 1 MB of RAM add \$148

Jade 20MHz Turbo 386\$1998
1 MB of RAM on Motherboard
1:1 Interleave FDD/HD Controller
2 Serial, 1 Parallel, Clock, Calendar
101 Enhanced Keyboard

40 MB Mono Graphics System*2388
1.2 MB Floppy Disk Drive
40 MB Hard Disk Drive
Amdek 310A Monitor

Disk Drives
360K half height\$68
360K full height\$118
TEAC 55 BV\$78
1.2 MB for AT\$88
3 1/2" 720K\$88
3 1/2" 1.44 MB\$118
5 1/4" ext. 360K for PS/2\$218
5 1/4" ext. 1.2 MB for PS/2\$258
5 1/4" ext. for LapTop\$298

Hard Disk Drives
10 MB w/controller\$148
20 MB w/controller\$238
30 MB w/controller\$288
40 MB w/controller\$398
40 MB for AT\$338
ST 125 20 MB\$248
ST 138 30 MB\$298
ST 251 40 MB\$368
ST 251-1 40 MB\$448
ST 4096 80 MB\$568

Tape Back-up
CMS Jumbo 40 MB XT/AT\$298
XT/AT Kit External\$128
PS/2 Internal Kit\$58
PS/2 External Kit\$128

Monitors
Amdek 310A amber\$98
Amdek 410A amber\$118
14" amber flat screen\$128
RGB 640 X 240 color\$258
EGA 640 x 350 color\$378
VGA 640 x 480\$398
NEC MultiSync IICall
NEC MultiSync II 2A\$528
Mitsubishi Diamond Scan\$498
Zenith 1490 flat screen\$618
Sony 800 x 600 Multi Scan\$488

Keyboards
84 Key AT-style\$68
101 Key enhanced\$78

Printers
EPSON LX-800 9 PIN\$188
EPSON FX-850Call
EPSON FX-1050Call
EPSON EX-800Call
EPSON DFX-5000Call

EPSON LQ-500 24 PINCall
EPSON LQ-850Call
EPSON LQ-950Call
EPSON LQ-1050Call
Okidata 320\$348
Okidata 321\$498
Okidata 390\$498
Okidata 391\$648
Okidata 393\$948

Panasonic KX-P1180\$178
Panasonic KX-P1191\$239
Panasonic KX-P1124\$318
Panasonic KX-P1592\$388
Panasonic KX-P1092i\$318
Panasonic KX-P1595\$438
Panasonic KX-P1524\$538
Panasonic KX-P4450\$1548

Daisywheel Printer
40 CPS Parallel and serial\$199

Hewlett Packard DeskJet
DeskJet\$698
EPSON emulation cartridge\$68
TMS RM/HELV Soft Font\$98
Ink cartridge\$19

Hewlett Packard LaserJet
LaserJet IICall
LaserJet IIDCall
25 in One Font Cartridge\$398
4 MB card w/0 memory\$188
1 MB memory card\$348
2 MB memory card\$648
4 MB memory card\$1148
Toner cartridge\$98

Terminals
WYSE model 30\$288
WYSE model 50\$368
WYSE model 85\$438

Joystick
Kraft 3 button Joystick\$19
Dual Game Port\$19

Plotter
Roland DXY-980\$698
Houston InstrumentsCall

Scanner
Complete Hand Scanner\$148
Complete 4" Scanner\$198
Logitech Scan Man\$248
Diamond Flower 3000\$198
Hewlett Packard ScanJetCall

Digitizers
Summa Sketch 12 x 12\$378

Mouse
Opto-mechanical
with Software\$29

LogiTech
LogiMouse Serial\$68
LogiMouse Bus\$78
LogiMouse Hi-rez\$88

Mouse Systems
PC Mouse with Paint\$88

Microsoft
Mouse w/Paintbrush\$98
Mouse w/CADCall
Mouse w/WindowCall

Complete PC
Complete FAX 4800\$228
Complete FAX 9600\$388
Complete Answering Machine\$248

Switch Boxes
Parallel or Serial (Specify)
2 way AB\$28
3 way ABC\$38
4 way ABCD\$58
5 way ABCDE\$68
Crossover X\$68
AutoSwitch 3 way\$198
AutoSwitch 6 way\$248

Modems
1200 internal w/software\$48
2400 internal w/software\$98
1200 external\$88
2400 external\$148
2400 PS/2 internal\$198
Intel 2400B for PS/2\$278

Intel
8087\$94
8087-2\$138
8087-1\$178
80287-6\$148
80287-8\$218
80287-10\$248
80387-SX\$348
80387-16\$378
80387-20\$398
80387-25\$528
Above board 286 Plus 512K\$418
In board 386\$1028

Cables
6' printer\$12
10' printer\$18
25' printer\$28
9' serial\$18
25' serial\$28
50' serial\$38
100' serial\$58
Keyboard extender\$12
Monitor extender\$16
Printer extender\$16

Boards
Monographics w/Parallel\$48
Color Graphics w/Parallel\$48
Jade EGA card\$158
Jade VGA+\$238
Jade VGA+ 16\$288
Dual game port\$19
XT I/O Par/Ser/Clk/Game\$58
AT I/O Par/Ser/Game\$58
360/720K 1.2/1.44 MB FDC\$48
AT FDD/HD controller\$98
XT Hard Disk controller\$58
AST SixPak Plus\$118
AST XFormer\$578
Paradise auto EGA 350\$168
Paradise VGA+\$268
Paradise VGA+ 16\$318

Surge Protector
S. L. Waber 6 outlet\$18
Isobar 4 outlet\$48
Isobar 8 outlet\$68
Isobar modem protector\$24

Tripplite Battery Back-up
450 Watt UPS\$398
750 Watt UPS\$498
1200 Watt UPS\$698

Tripplite Line Stabilizer
600 Watt LC\$98
1200 Watt LC\$158
1800 Watt LC\$188

Accessories
Kensington Master Piece\$88
AC Master Control Center\$48
MicroSpeed PC-Trac Ball\$78
Vertical CPU stand\$18
Keyboard drawer\$58
Monitor Tilt-n-Swivel\$18

4901 W. Rosecrans Ave. Box 5046
Hawthorne, California 90251-5046



JADE COMPUTER

California
Torrance, Costa Mesa, Woodland Hills
Kearny Mesa, Sunnyvale

Texas
Addison, Houston

Georgia
Smyrna

Arizona
Phoenix

Not all items in stock at our nine retail locations.



Place orders and use our technical support toll free!
Continental U.S.A. 1-800-421-5500 Inside California 1-800-262-1710
Fax machine 1-213-675-2522/All others 1-213-973-7707

We accept checks, credit card or purchase orders from qualified firms and institutions. No surcharge on credit card orders. CA., TX, GA. & AZ. residents add sales tax. Prices and availability subject to change without notice. Shipping and handling charges via UPS ground 50¢/lb. UPS air \$1.00/lb. Minimum charge \$4.00.

**NEW
LOW
PRICES**

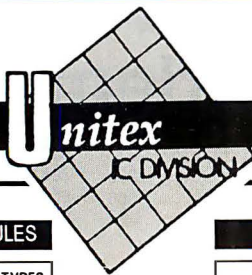

Special of the Week
SIMM 1MG X9-100 NS.....only \$249⁰⁰

ESTABLISHED 1976

SIMM MODULES

1 MG X 9- for IBM TYPES
1 MG X 9-120 NS \$229
1 MG X 9-100 NS \$249
1 MG X 9-80NS \$299
1MG X9-70NS \$349

256 X 9- for IBM TYPES
256 X 9-120NS \$75
256 X 9-100NS \$99
256 X 9-80NS \$119
256 X 9-60NS \$139
AVAILABLE IN PAGE OR
STATIC COL.

1 MG X 8 - for APPLE
1 MG X 8-120NS ... \$229
1 MG X 8-100NS ... \$249

256 X 8 - for APPLE
256 X 8-120NS \$69
256 X 8-100NS \$79

PS-2 SIMM'S
256 X 9 (FOR PS2)
256 X 9-120NS \$99
256 X 9-100NS \$109

512 X 9 (FOR PS2)
512 X9-100 \$199

PS-2MODEL 70&80 SIMM
1 MG X 9-100NS .. \$269
1 MG X 9-80NS \$349
2 MG X 9-80NS \$679



D - RAM

1 MG X 1
1 MG X 1-120 NS \$20
1 MG X 1-100 NS \$22
1 MG X 1-80NS \$26

256 X 1
256 X 1-150 NS ...\$7.50
256 X 1-120 NS ...\$8.25
256 X 1-100NS ...\$8.75
256 X1-80NS\$9.50
256 X 1-60NS \$10.50

256 X 4
256 X 4-120 NS \$23
256 X 4-100 NS \$25
256 X 4-80NS \$27

64 X 1
4164-150NS \$1.90
4164-120NS \$2.40
4164-100NS \$ 2.90

64 X 4
4464-150 NS \$9
4464-120 NS \$10
4464-100NS \$11
4464-80NS \$12

MEMORY EXPANSION FOR 70 or 80
• EXPANDS TO 8MG
• COMES WITH 2 MG
• OUR PRICE \$1329
• IBM LIST \$1595
• ADDITIONAL 6MG - ONLY \$2000

MATH CO-PRO

8087-3(5MHZ) \$89
8087-2(8MHZ) \$139
8087-1 \$170
80287-6 \$130
80287-8 \$195
80287-10 \$220
80387-16 \$320
80387-20 \$400
80387-25 \$510

80386-16 \$189
80386-20 \$289
80386-25 \$499

VIDEO RAM FOR VGA CARDS

64 x 4(150NS) \$13
64 X 4(120ns) \$16
64 X 4(100ns) \$21

D-RAM TESTER only \$169

Tests the following memory chips:
64K X 1 256 X 1
64K X 4 256 X 4
4MX 1 1M X 4
The RTI can help anyone come through the frustrating process of identifying bad (or good) D-RAM chips. The weight and durability of the tester, make portability a breeze, whether it be on site, in the lab or in your tool kit. Don't be caught without one!!

MEMORY EXPANSION BOARDS

AST

Advantage 2 \$CALL
Advantage 2-386 \$CALL
Rampage 2 for XT-256K \$279
Rampage 286 w/512K \$395
Rampage 286-2 for model 50/60 \$549
Six Pac Plus w/64K \$118
w/384K \$269
Hot Shot \$355

EVEREX

Mini-Magic w/θ K \$59
RAM 11 4000 \$CALL

IDEA associates

IDEA max 80 \$CALL
IDEA max MC \$CALL
Super max MC \$CALL

IBM

1497259 (for 50/60) \$495
6450605 (for 70/80)w2 MG \$1329

INTEL

Above BD 512K plus \$449
Above BD Piggyback 2MB .. \$CALL
Above BD Piggyback 6MB .. \$CALL
Above BD 2 plus θK \$349

ORCHID

Ram Quest Extra w/θK \$279
Ram Quest XT/AT w/θK \$239
Ram Quest II w/θK \$169

TERMS AND CONDITIONS

NO SURCHARGE FOR MC/VISA TERMS :

**MC • VISA • COD • CASH
AMEX add 4%**

Purchase Orders from Qualified Firms
20% Restocking Fee on non-defective returns
Prices Subject to Change

VIDEO ADAPTER

ATI
EGA WONDER 800 \$169
VIP VGA \$249

VIDEO 7
Fastwrite VGA \$379
RV-RAMVGA (AT) \$519
Vega Deluxe \$229
Vega VGR \$269

ORCHID
DesignPro Designer \$298
Designr VGA800 \$239

PARADISE
BASIC EGA \$175
VGA PLUS 16/256K \$299
VGA PRO/512 \$499

UNITEX
MONOGRAPHS W/PAR \$46
COLORGRAPHS W/PAR \$46
EGA CARD \$158
VGA CARD \$268

MODEMS

EverCom 12 300/1200 bps Bitcom Software... \$74
EverCom 24 2400 Baud Int. Bitcom Software \$139
External 2400 Baud \$199

Hayes Compatible Major Manufacturers

1200 Baud Internal w/Software \$59
1200 Baud External fully Hayes compatible .. \$99
2400 Baud Internal 1/2 card w/software \$109
2400 Baud External Fully Hayes Compatible \$129

MONITORS

12" Amber with tilt & Swivel base \$79
12" Amber Flat Screen 720X350 \$99
14" Color 640X200, 16 colors \$239
14" EGA 640X350, 64 Colors/.31 \$369
EGA 720X480 \$439



2852 F Walnut - Tustin, CA 92680
Phone: 714/730-5232 • FAX#: 714/838-8593



TOLL FREE OUTSIDE CA: 1/800/533-0055

ACP's HOT SHEET

BELOW
WHOLESALE
PRICES!

MEMBER
MMC
MICROCOMPUTER
MARKETING COUNCIL
of the Direct Marketing Association, Inc.

SPECIAL BUY!
HANDSCAN
by **saba™**

299. List 799!

Don't confuse Handscan with other lowest cost scanners on the market...many deluxe features! Never before available at this special low price...order now!

Princeton Graphics **LS-300**
Full-Page Scanner

Very popular and reliable feed-thru scanner for up to 8.5x11" size sheets. Complete with OCR Software. IBM compatible. Mfg. List \$1199.00!

SHARP PC7221
286 Portable

Compare to Compaq Portable III and save...
• Backlit screen
• 10 MHz • 102 key board
• 20 Mb hard drive, 640K
• 8 or 16 bit internal slot

799. sale **1499.**

AST RESEARCH INC.
Your Choice...
Advantage AT or Rampage AT **88.**

QUADRAM Silver Quad **79.**
(Sixpak compatible)

• Liberty XT, EMS 79.
• Quadprint Accelerator.. 79.

BLOW OUT PRICE!

7995

Migent® Pocket Modem™

This popular 1200 Baud pocket modem comes w/o software & has never been offered at such a low price!

OUR NO. 1 SELLERS!!!
Hayes Compatible
1200 Baud

Internal **49.** External **7495**

Hayes Compatible
2400 Baud

Internal **9595** External **11995**

Both are half-cards, with software, plug 'n play!

NUMONICS CORPORATION

SPECIAL PURCHASE!!!

Cordless Mouse **8895**

includes drivers, charger, receiver, mouse & PC Paint

Manager Mouse **5595**

includes drivers, charger, receiver, mouse & PC Paint

5.25" Diskette Sale!
3995 Genuine IBM™
100 pc.box

All disks are from IBM™ and are formatted to PC DOS 360K DS/DD 5-1/4". Disks are programmed but can easily be erased by Deleting Data and reusing the diskettes. You get IBM™ quality Diskettes for only 39¢. All disks are new, formatted and programmed but never used.

RATED NO. 1!!!

Box of 10... **699** Quantity of 1 to 4, only 7.50 each.

more to choose...
• 3.5" DS/DD 1 Mb. 16.50
• 3.5" HD 2 Mb. 39.95
• 5.25" HD 1.6 Mb 14.99

Polaroid® DataRescue™
IBM DS/DD Gray Disks

Backed by DATA RESCUE...Polaroid will retrieve your data FREE if you lose it!

SPECIAL! 512K RAM Upgrade with purchase... 99.

688. ACP Sale Price

Note: FOR THIS PRICE YOU MUST MENTION THIS AD AT TIME OF PURCHASE

AMAX/Advanced 286/10 MHz BareBones

Includes 101-key keyboard, 1.2Mb floppy, floppy/HD controller card, 0K expands to 1 Meg.
Call for Custom Configurations...

SPECIAL PURCHASE!

IBM 299.

Reg. \$895. Roll-A-Bout Computer Workstation
• One lock secures CPU, printer & programs
• 5-plug strip w/mstr switch • Flip-up shelves
• Printers up to 24" wide • 132lb. ship wt.

SPECIAL PURCHASE!!!

85Mb Hard Drive
Includes EDSI AT Controller...

Special! Upgrade your IBM™ AT or compatible with our popular 60 ms half-height hard drive. **699.**

20 Mb Hard Drive Kit **259.**

20 Mb Hard Card **288.**

At this low low price, you can't afford not to buy one...our next shipment the price will go up...

Tecmar "Micro RAM" PS/2

Expand your PS/2 up to 8Mb
Reg. Retail \$439. **5995**
ACP Sale Price
734-0003 • While Supply Lasts

QuickLink IV 4-User LAN
by Cubix

• 4 286 Processors
• 786K RAM per user (3Mb total)
• NOVELL CERTIFIED
• Your PC/AT and 4 terminals give you a fast, inexpensive LAN
Reg. \$2800. **1995.**
ACP Sale...

Toshiba T-1000 • Hayes compatible **266** Retail \$349.
2400B Modem Mirror II software
Correspondent™ • 2 yr. warranty Holmes Microsystems

PARADISE™ VGA-PLUS • VGA/EGA/HDA comp. **269.**
• 256K on board
the Performance Leader...Reg. \$399, #625-0004.

Hi-Tech Silicon Corner

• MOT 68881-16 (16 MHz) Coprocessor...**188.**
• Intel 80287-6 (8 MHz) Coprocessor...**139.**
• DP 8428V-70 1Mb RAM Controller...**14.95**
• MOT MC 68766C30 EPROM...**29.95**

IBM (Original) Floppy Disk Drive!!!
Original DS/DD 360K Drives, 5-1/4" Factory Boxed
5995 Super Price!
While Quantities Last

"LASERNET" 8 Port Buffer **449.**
by Western Telematic Retail \$995.
• 8 Serial Input Ports # 400-0076
• 1 Serial, 1 Parallel Output
• 256K Buffer expands to 2Mb
Model PSU-82C Printer Share

Postscript compatible, Menu-driven, Set-up software

IBM™ Blowout Sale!!!

this has never been offered to the remarketing channel by IBM™ before... and we bought big! 8 big truckloads of IBM PC's, expansion boards, memory and over 60,000 real IBM software packages... First come, first served... call for complete list!

- IBM XT/286 **1395.**
- IBM AT/339(OK) **2295.**
- IBM PC/3270(1Mb) **1295.**
- IBM PC/XT268 **788.**
- PC Voice Comm Card **229.**
- AT Exp Card w/512K **149.**
- Monochrome adaptor **49.**
- Color adaptor **49.**
- AT Prototype board **25.**
- Synchronous Adaptor **49.**
- IEEE Adaptor **99.**
- 3270 Exp Card, 1Mb **499.**
- IBM Reporting Asstnt **25.**
- IBM AT 2Mb Memory Expansion Brd w/OK **69.**
- IBM Writing Asstnt **19.95**
- IBM Filing Asstnt **19.95**
- IBM Fortran **99.95**
- IBM LOGO **59.95**
- IBM 3270 Emulator **24.95**
- IBM 3101 Emulator **69.95**
- IBM Education Series
- Software, choose **995**
- 300 titles from **995**
- IBM DOS 1.0/3.1 from 9.95

SEND OR CALL FOR THE COMPLETE LIST!

IBM™ Filing Assistant BUNDLE-all 5 pkgs. 79.95!
• IBM Filing Assistant, Reg. \$204.00! **19.95**
• IBM Assistant Executives Solutions (reqs. Filing Ass't) **24.95**
• IBM Assistant Accounting Solutions (reqs. Filing Ass't) **24.95**
• IBM Assistant Home Solutions (reqs. Filing Ass't) **24.95**

IBM™ Decision Series BUNDLE-all 4 pkgs. 79.95!
• IBM Data Edition, Reg. \$255.00 **24.95**
• IBM Reports+ Edition, Reg. \$204.00 **19.95**
• IBM Graphs Edition, Reg. \$204.00 **19.95**
• IBM Plans+ Edition, Reg. \$335.00 **29.95**

Call for complete listing and get deals like these...
IBM™ Language Education BUNDLE-any 10 pkgs 129.95
or **IBM™ Science Education BUNDLE-any 10 pkgs 139.95**

CALL FOR TOSHIBA LAPTOPS!!

499. TOSHIBA 321SL Sale!

CITIZEN ACP's • 120d.. 144.95 Sale! • 180d.. 189.95

IBM 2Mb/OK Memory Expansion Board
for AT or compatibles **69.** While Supply Lasts!

Unbelievable Low Price...
• 512K AT Memory Expansion Board/512K... **149.**

Samsung XT/10 MHz **599.**

• 512K RAM • 360K floppy
• Serial/Parallel/Clock Card
• DOS 3.3 GW Basic

ACP's Special Wholesale Price... **995** New! from RAY-O-VAC®
AT Replacement Battery
Direct replacement for AT/286/386 real-time clocks

Software Sale! IBM Writing Ass't, v2. **59.**
Lotus 1-2-3 **325.** Word Perfect **258.**
Ventura **499.** Excel **299.**

719. New Low Price with Card!
Full Page 15" MONITOR for IBM

for the **FASTEST SERVICE** order by phone...
Mail Orders: P.O. Box 17329 Irvine, CA 92713
Retail: 1310 E. Edinger, Santa Ana, CA 92705
Advanced Computer Products, Inc.

800-FONE ACP
800-366-3227 • 714-558-8813
Customer Service 714-558-1356

• \$25.00 Minimum MAIL ORDER
• No Surcharge for VISA or Mastercard
• Volume purchasing agreements available
• Pricing subject to change without notice
• ACP Retail store pricing may vary. Not responsible for typos.
• Limited warranties and other conditions may apply

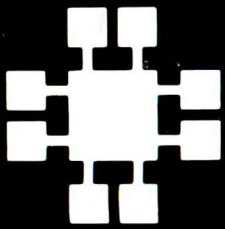

JDR Microdevices

• 30 DAY MONEY BACK GUARANTEE • 1 YEAR WARRANTY ON ALL PRODUCTS • TOLL-FREE TECHNICAL SUPPORT
• COMPLETE CUSTOMER SATISFACTION • SUPERIOR SERVICE • FRIENDLY, KNOWLEDGEABLE SALES STAFF

EPROMS

| PART | SIZE | SPEED | V _{pp} | PRICE |
|------------|----------|-------|-----------------|-------|
| 2708 | 1024x8 | 450ns | 25V | 4.95 |
| 2716 | 2048x8 | 450ns | 25V | 3.49 |
| 2716-1 | 2048x8 | 350ns | 25V | 3.95 |
| 2732 | 4096x8 | 450ns | 25V | 3.95 |
| 2732A | 4096x8 | 250ns | 21V | 3.95 |
| 27C64 | 8192x8 | 250ns | 12.5V | 4.95 |
| 2764 | 8192x8 | 450ns | 12.5V | 3.49 |
| 2764-250 | 8192x8 | 250ns | 12.5V | 3.69 |
| 2764-200 | 8192x8 | 200ns | 12.5V | 4.25 |
| 27128 | 16384x8 | 250ns | 12.5V | 4.95 |
| 27128A-200 | 16384x8 | 200ns | 12.5V | 5.95 |
| 27C256 | 32768x8 | 250ns | 12.5V | 7.95 |
| 27256 | 32768x8 | 250ns | 12.5V | 5.95 |
| 27256-200 | 32768x8 | 200ns | 12.5V | 7.95 |
| 27512 | 65536x8 | 250ns | 12.5V | 11.95 |
| 27C512 | 65536x8 | 250ns | 12.5V | 12.95 |
| 27C101-20 | 131072x8 | 200ns | 12.5V | 34.95 |

■ CALL TO CONFIRM CURRENT PRICES ■

STATIC RAMS

| PART | SIZE | SPEED | PRICE |
|--------------|---------|-------|-------|
| 2114 | 1024x4 | 450ns | .99 |
| 2114L-2 | 1024x4 | 200ns | 1.49 |
| TC5516 | 2048x8 | 250ns | 3.95 |
| TMM2016-200 | 2048x8 | 200ns | 3.25 |
| TMM2016-150 | 2048x8 | 150ns | 3.29 |
| TMM2016-100 | 2048x8 | 100ns | 4.29 |
| HM6116-4 | 2048x8 | 200ns | 4.95 |
| HM6116-3 | 2048x8 | 150ns | 5.95 |
| HM6116-2 | 2048x8 | 120ns | 6.45 |
| HM6116LP-4 | 2048x8 | 200ns | 5.95 |
| HM6116LP-3 | 2048x8 | 150ns | 6.45 |
| HM6116LP-2 | 2048x8 | 120ns | 6.95 |
| HM6264LP-15 | 8192x8 | 150ns | 9.95 |
| HM6264LP-12 | 8192x8 | 120ns | 10.95 |
| HM43256LP-15 | 32768x8 | 150ns | 17.95 |
| HM43256LP-12 | 32768x8 | 120ns | 19.95 |
| HM43256LP-10 | 32768x8 | 100ns | 24.95 |

■ CALL TO CONFIRM CURRENT PRICES ■

DYNAMIC RAMS

| PART | SIZE | SPEED | PRICE |
|-------------|-----------|-------|-------|
| 4116-200 | 16384x1 | 200ns | .89 |
| 4116-150 | 16384x1 | 150ns | 2.89 |
| 4164-150 | 65536x1 | 150ns | 2.89 |
| 4164-120 | 65536x1 | 120ns | 3.19 |
| 4164-100 | 65536x1 | 100ns | 3.95 |
| TMS4416 | 16384x4 | 150ns | 8.95 |
| 41128-150 | 131072x1 | 150ns | 5.95 |
| TMS4464-15 | 65536x4 | 150ns | 14.95 |
| TMS4464-12 | 65536x4 | 120ns | 15.95 |
| 41256-150 | 262144x1 | 150ns | 7.99 |
| 41256-120 | 262144x1 | 120ns | 8.49 |
| 41256-100 | 262144x1 | 100ns | 8.79 |
| 41256-80 | 262144x1 | 80ns | 9.49 |
| MK4332 | 32768x1 | 200ns | 6.95 |
| HMS1258-100 | 262144x1 | 100ns | 13.95 |
| 1 MB-120 | 1048576x1 | 120ns | 24.95 |
| 1 MB-100 | 1048576x1 | 100ns | 27.95 |

■ CALL TO CONFIRM CURRENT PRICES ■

CO-PROCESSORS

| | | |
|----------|--------|--------|
| 8087 | 5 MHz | 97.95 |
| 8087-2 | 8 MHz | 139.95 |
| 8087-1 | 10 MHz | 189.95 |
| 80287 | 6 MHz | 157.96 |
| 80287-8 | 8 MHz | 254.95 |
| 80287-10 | 10 MHz | 297.95 |
| 80387-16 | 16 MHz | 389.95 |
| 80387-SX | 16 MHz | 389.95 |
| 80387-20 | 20 MHz | 469.95 |
| 80387-25 | 25 MHz | 589.95 |

intel
5 YEAR WARRANTY

INCLUDES MANUAL & SOFTWARE GUIDE

EPROM ERASERS

DATARASE II \$39.95

- SHIRT POCKET SIZE!
- ERASES MOST EPROMS/ EPLD'S IN 3 MINUTES ■ ALL SIZES UP TO 4 AT A TIME



SPECTRONICS CORPORATION

| Model | Timer | # of Chips | Intensity (uW/Cm ²) | Unit Cost |
|---------|-------|------------|---------------------------------|-----------|
| PE-140 | NO | 9 | 8,000 | \$89 |
| PE-140T | YES | 9 | 8,000 | \$139 |
| PE-240T | YES | 12 | 9,600 | \$189 |
| PL-265 | YES | 30 | 9,600 | \$255 |



HIGH-TECH SPOTLIGHT

MAXTOR DISK DRIVES

THESE DRIVES ARE BIG, FAST AND BUILT TO LAST!
AN EXCELLENT VALUE! GIVE YOUR SYSTEM EXTRA SPEED AND STORAGE SPACE. THESE HIGH-QUALITY MAXTOR DRIVES ARE BUILT FOR YEARS OF DEPENDABLE SERVICE-- THEY HAVE A FIELD-PROVEN MTBF (MEAN TIME BETWEEN FAILURES) OF NEARLY 8 YEARS.

| MB | MODEL | AVG. SPEED | INTERFACE | PRICE |
|-------|----------|------------|-----------|--------|
| 120MB | XT-1140 | 27MS | ST-506 | \$1595 |
| 160MS | XT-2190 | 29MS | ST-506 | \$1695 |
| 340MB | XT-4380S | 16MS | SCSI | \$2395 |

PARTIAL LISTINGS ONLY! CALL FOR COMPLETE CATALOG

74 SERIES LOGIC

| 7400 | | 7450 | |
|-------|------|----------|------|
| 7400 | .19 | 74LS76 | .29 |
| 7402 | .19 | 74LS83 | .49 |
| 7404 | .19 | 74LS85 | .49 |
| 7405 | .25 | 74LS86 | .22 |
| 7406 | .29 | 74LS90 | .39 |
| 7407 | .29 | 74LS92 | .49 |
| 7408 | .24 | 74LS93 | .39 |
| 7410 | .19 | 74LS109 | .39 |
| 7411 | .25 | 74LS112 | .29 |
| 7414 | .49 | 74LS123 | .49 |
| 7416 | .25 | 74LS125 | .39 |
| 7417 | .25 | 74LS132 | .39 |
| 7420 | .19 | 74LS138 | .39 |
| 7432 | .29 | 74LS139 | .39 |
| 7447 | .89 | 74LS151 | .39 |
| 7473 | .34 | 74LS153 | .39 |
| 7474 | .33 | 74LS154 | 1.49 |
| 7475 | .45 | 74LS155 | .59 |
| 7476 | .35 | 74LS156 | .49 |
| 7586 | .35 | 74LS157 | .35 |
| 7489 | 2.15 | 74LS158 | .29 |
| 7490 | .39 | 74LS161 | .39 |
| 7493 | .35 | 74LS163 | .39 |
| 74121 | .29 | 74LS164 | .49 |
| 74123 | .49 | 74LS165 | .65 |
| 74151 | .55 | 74LS166 | .95 |
| 74154 | 1.49 | 74LS175 | .39 |
| 74157 | .55 | 74LS176 | .39 |
| 74166 | 1.00 | 74LS192 | .69 |
| | | 74LS193 | .69 |
| | | 74LS197 | .59 |
| | | 74LS221 | .59 |
| | | 74LS240 | .69 |
| | | 74LS241 | .69 |
| | | 74LS244 | .79 |
| | | 74LS245 | .79 |
| | | 74LS251 | .49 |
| | | 74LS257 | .39 |
| | | 74LS258 | .49 |
| | | 74LS259 | 1.29 |
| | | 74LS260 | .49 |
| | | 74LS273 | .79 |
| | | 74LS279 | .39 |
| | | 74LS322 | 3.95 |
| | | 74LS323 | 2.49 |
| | | 74LS367 | .39 |
| | | 74LS373 | .79 |
| | | 74LS374 | .79 |
| | | 74LS377 | .79 |
| | | 74LS393 | .79 |
| | | 74LS541 | 1.49 |
| | | 74LS670 | .89 |
| | | 74LS672 | 3.20 |
| | | 74LS678 | 2.40 |
| | | 74LS688 | 2.40 |
| | | 74500 | .29 |
| | | 74502 | .29 |
| | | 74504 | .29 |
| | | 74574 | .49 |
| | | 74586 | .35 |
| | | 745112 | .50 |
| | | 745287 | 1.69 |
| | | 745288 | 1.69 |
| | | 745374 | 1.69 |
| | | S32 | .35 |
| | | S138 | .79 |
| | | S240 | 1.49 |
| | | S244 | 1.49 |
| | | S373 | 1.69 |
| | | 74F | |
| | | 74F00 | .35 |
| | | 74F04 | .35 |
| | | 74F08 | .35 |
| | | 74F32 | .35 |
| | | 74F74 | .39 |
| | | 74F138 | .79 |
| | | 74F244 | 1.29 |
| | | 74HC | |
| | | 74HC00 | .21 |
| | | 74HC04 | .25 |
| | | 74HC06 | .25 |
| | | 74HC14 | .35 |
| | | 74HC32 | .35 |
| | | 74HC74 | .35 |
| | | 74HC138 | .45 |
| | | 74HC139 | .45 |
| | | 74HC154 | 1.09 |
| | | 74HC157 | .55 |
| | | 74HC244 | .85 |
| | | 74HC245 | .85 |
| | | 74HC373 | .69 |
| | | 74HC374 | .69 |
| | | 74HCT | |
| | | 74HCT00 | .25 |
| | | 74HCT04 | .27 |
| | | 74HCT08 | .25 |
| | | 74HCT32 | .35 |
| | | 74HCT138 | .25 |
| | | 74HCT240 | .89 |
| | | 74HCT244 | .89 |
| | | 74HCT245 | .99 |
| | | 74HCT373 | .99 |
| | | 74HCT374 | .99 |

MICROPROCESSORS

| 6500 | | 8000 | | 8200 | |
|--------|--------|---------|-------|-------------|-------|
| 6502 | 2.25 | 8031 | 3.95 | 8254 | 2.79 |
| 6502A | 2.69 | 8035 | 1.49 | 8255 | 1.99 |
| 6502B | 4.25 | 8039 | 1.95 | 8255-5 | 2.49 |
| 65C02* | 7.95 | 8052AH | | 8256 | 15.95 |
| 6522 | 2.95 | BASIC | 34.95 | 8259 | 1.95 |
| 6526 | 13.95 | 8080 | 2.49 | 8259-5 | 2.29 |
| 6532 | 5.95 | 8085 | 1.95 | 8272 | 4.39 |
| 6551 | 2.95 | 8085A-2 | 3.75 | 8274 | 4.95 |
| 6581 | 14.95 | 8088 | 5.99 | 8275 | 16.95 |
| * CMOS | | 8088-2 | 7.95 | 8279 | 2.49 |
| | | 8155 | 2.49 | 8279-5 | 2.95 |
| | | 8155-2 | 3.95 | 8282 | 3.95 |
| | | 8155 | 2.95 | 8283 | 3.95 |
| 6800 | 1.95 | 6741 | 9.95 | 8284 | 2.25 |
| 6802 | 2.95 | 8748 | 7.95 | 8286 | 3.95 |
| 6803 | 3.95 | 8749 | 9.95 | 8287 | 3.95 |
| 6809 | 2.95 | 8755 | 14.95 | 8288 | 4.95 |
| 68B09 | 5.99 | | | | |
| 6809E | 2.95 | | | | |
| 68B09E | 5.49 | 8205 | 3.29 | Z80-CPU | 1.25 |
| 6808 | 2.49 | 8212 | 1.49 | Z80A-CPU | 1.29 |
| 6810 | 1.95 | 8216 | 1.49 | Z80B-CPU | 2.75 |
| 6821 | 1.25 | 8224 | 2.25 | Z80A-CTC | 1.69 |
| 68B21 | 1.85 | 8228 | 2.25 | Z80B-CTC | 2.25 |
| 6840 | 3.95 | 8237 | 3.95 | Z80A-DART | 5.95 |
| 6845 | 2.75 | 8237-5 | 4.75 | Z80B-DART | 6.95 |
| 6847 | 4.75 | 8238 | 4.49 | Z80A-DMA | 5.95 |
| 6850 | 1.95 | 8243 | 1.95 | Z80A-PIO | 1.89 |
| 68B50 | 1.75 | 8250 | 6.95 | Z80B-PIO | 4.25 |
| 6852 | 4.95 | 8251 | 1.29 | Z80A-SIO/0 | 5.95 |
| 6883 | 22.95 | 8251A | 1.69 | Z80A-SIO/1 | 5.95 |
| 68000 | 9.95 | 8253 | 1.59 | Z80A-SIO/2 | 5.95 |
| 68020 | 189.95 | 8253-5 | 1.95 | Z8671 BASIC | 9.95 |

SIMM MODULES

| SIZE | TYPE | AVG. SPEED | INTERFACE | PRICE |
|-------------|--------------|------------|-----------|----------|
| 41256A8B-15 | 256K x 8-BIT | FOR MAC | 150ns | \$89.00 |
| 41256A8B-12 | 256K x 8-BIT | FOR MAC | 120ns | \$95.00 |
| 41256A8B-10 | 256K x 8-BIT | FOR MAC | 100ns | \$95.00 |
| 41256A9B-15 | 256K x 9-BIT | FOR PC | 150ns | \$94.00 |
| 41256A9B-12 | 256K x 9-BIT | FOR PC | 120ns | \$99.00 |
| 41256A9B-10 | 256K x 9-BIT | FOR PC | 100ns | \$109.00 |
| 41256A9B-80 | 256K x 9-BIT | FOR PC | 80ns | \$119.00 |
| 42100A9B-10 | 1MB x 9-BIT | FOR PC | 100ns | \$329.00 |
| 42100A9B-80 | 1MB x 9-BIT | FOR PC | 80ns | \$399.00 |

V-20 SERIES

SPEED UP YOUR PC BY 10% TO 40%
■ HIGH SPEED ADDRESS CALCULATION IN HARDWARE ■ PIN COMPATIBLE WITH 8088
■ LOW POWER CMOS
■ SUPERSET OF 8088 INSTRUCTION SET

| | | | |
|------------|-------|-----------|-------|
| V20 5 MHz | 6.95 | V20 8 MHz | 8.95 |
| V20 10 MHz | 11.95 | V30 8 MHz | 13.95 |

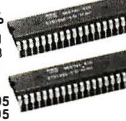

PALS

| | | | |
|------|--------|------|--------|
| 16L8 | \$2.95 | 20R4 | \$4.95 |
| 16R8 | 2.95 | 20R6 | 4.95 |
| 16R6 | 2.95 | 20R8 | 4.95 |
| 16R4 | 2.95 | 20X8 | 4.95 |
| 20L8 | 4.95 | | |

STARTER KIT

EASY TO USE PAL PROGRAMMING KIT FOR ALL THE PAL DEVICES AT LEFT.
MCT-PAL-SOFT \$99.95

LINEAR COMPONENTS

| | | | | | |
|--------|------|-------|------|--------|------|
| TL071 | .69 | TL497 | 3.25 | MC3487 | 2.95 |
| TL072 | 1.09 | NE555 | .29 | LM3900 | .49 |
| TL084 | 1.49 | NE556 | .49 | LM3909 | .98 |
| LM301 | .34 | NE558 | .79 | LM3914 | 1.89 |
| LM309K | 1.25 | LM565 | .95 | IC7760 | 1.99 |
| LM311 | .59 | LM567 | | | |

POWER SUPPLIES



- 135 WATT POWER SUPPLY**
 ■ UL APPROVED
 ■ +5V @ 15A, +12V @ 4.2A,
 -5V @ .5A, -12V @ .5A
PS-135 \$59.95
PS-150 150W SUPPLY \$69.95
- 200 WATT POWER SUPPLY**
 ■ UL APPROVED
 ■ +5V @ 20A, +12V @ 7A,
 -5V @ .5A, -12V @ .5A
PS-200 \$89.95
- APPLE TYPE SUPPLY**
 ■ WITH APPLE CONNECTOR
 ■ +5V @ 6A, +12V @ 3A,
 -5V @ 1A, -12V @ 1A
PS-A \$49.95
- 36 WATT POWER SUPPLY**
 ■ +5V @ 2.5A, +12V @ 1.5A
 ■ 3 PIN INPUT, 6 PIN OUTPUT
 ■ SELECTABLE 110V-220V
PS-3045 \$12.95

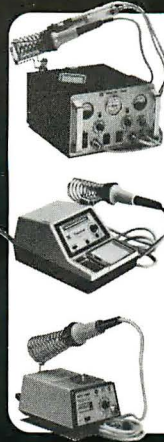

SOLDER STATIONS

- SOLDER/DESOLDER STATION**
 ■ OIL-FREE VACUUM PUMP
 ■ TEMP ADJUSTS (212° F-900° F)
 & VACUUM (0-60 CM/HG)
 ■ WITH GUN-REST, COOLING TRAY,
 WIRE BRUSH & TIP CLEANER ROD
XY999SD \$399.95
XY999D DESOLDER ONLY \$349.99
- DELUXE SOLDER STATION**
 ■ ROTARY SWITCH TEMP CONTROL (200° F-878° F RANGE)
 ■ LED TEMPERATURE READOUTS
 ■ INCLUDES COOLING TRAY
XY9-60L \$79.95
- SOLDER STATION**
 ■ UL APPROVED
 ■ HEAT SETTING ADJUSTS
 ■ TIP TEMPERATURE READOUT
 ■ REPLACEMENT TIPS @ \$2.95
168-3C \$59.95

WIREWRAP PROTOTYPE CARDS

FR-4 EPOXY GLASS LAMINATE WITH GOLD PLATED EDGE CARD FINGERS AND SILK SCREENED LEGENDS



- JDR-PR1** WITH +5V AND GROUND PLANE **\$27.95**
JDR-PR2 ABOVE WITH I/O DECODING LAYOUT **\$29.95**
- FOR AT**
JDR-PR10 16 BIT WITH I/O DECODING LAYOUT **\$34.95**
JDR-PR10PK PARTS KIT FOR JDR-PR10 ABOVE **\$12.95**
- FOR PS/2**
JDR-PR32 32 BIT PROTOTYPE CARD **\$69.95**
JDR-PR16 16 BIT WITH I/O DECODING LAYOUT **\$49.95**
JDR-PR16PK PARTS KIT FOR JDR-PR16 ABOVE **\$15.95**
JDR-PR16V 16 BIT FOR VIDEO APPLICATIONS **\$39.95**

JDR INSTRUMENTS—2 YEAR WARRANTY!

- 35 MHZ DUAL TRACE OSCILLOSCOPE**
 ■ WIDE BAND WIDTH ■ VARIABLE HOLDOFF
MODEL-3500 (SHOWN) \$499.95
- 20 MHZ DUAL TRACE OSCILLOSCOPE**
 ■ TV SYNC FILTER ■ COMPONENTS TESTER
MODEL 2000 \$389.95
- 3.5 DIGIT PROBE TYPE DMM**
 ■ AUTORANGING ■ AC/DC 2V - 500V, RESIS. 2K-2M
DPM-1000 (SHOWN) \$54.95
- 3.5 DIGIT POCKET SIZE DMM**
 ■ BASIC DC ACCURACY ±0.5% ■ 14 RANGES
DMM-100 \$29.95
- 3.5 DIGIT FULL FUNCTION DMM**
 ■ BASIC DC ACCURACY ±0.25% ■ 22 RANGES
DMM-200 \$49.95
- THE ULTIMATE 3.5 DIGIT DMM**
 ■ BASIC DC ACCURACY ±0.25% ■ 34 RANGES
 ■ TEMP, TRANSISTOR & RESISTANCE FEATURES
DMM-300 (SHOWN) \$79.95

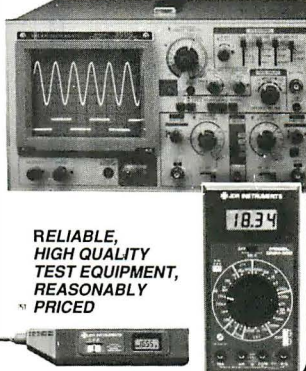

RELIABLE,
HIGH QUALITY
TEST EQUIPMENT,
REASONABLY
PRICED

DATA SWITCH BOXES

| TYPE | # OF POS. | PARALL | SERIAL | PRICE |
|----------|-----------|--------|--------|-------|
| PUSHBTNN | 2-WAY | AB-P | AB-S | 39.95 |
| ROTARY | 2-WAY | RSP-2 | RSS-2 | 24.95 |
| ROTARY | 3-WAY | RSP-3 | RSS-3 | 27.95 |
| ROTARY | 4-WAY | RSP-4 | RSS-4 | 29.95 |

COMPUTER CABLES

- GOLD-PLATED CONTACTS; 100% SHIELDED
- CBL-PRINTER PC PRINTER CABLE 9.95
 - CBL-PRINTER-25 AS ABOVE-25 FT. 15.95
 - CBL-PRINTER-RA RT. ANGL. PRINTER 15.95
 - CBL-DB25-MM DB25 MALE-MALE 9.95
 - CBL-DB25-MF DB25 MALE-FEMALE 9.95
 - CBL-9-SERIAL 9 PIN-25 PIN SERIAL 6.95
 - CBL-KBD-EXT KEYBOARD EXTEN. 7.95
 - CBL-CNT-MM 36 PIN CENTRON-MM 14.95
 - CBL-HD-20 20 PIN HARD DISK 3.95
 - CBL-HD-34D 34 PIN DUAL HARD DISK 6.95
 - CBL-FDC-EXT 37 PIN EXT. FLOPPY 9.95
 - CBL-MNT-9 9 PIN MONITOR EXTEN. 6.95
 - CBL-MODEM DB25-DB25 FEMALE 7.95

EXTENDER CARDS

FOR PROTOTYPE DEBUGGING, TESTING AND TROUBLESHOOTING

- EXT-8088 XT COMPATIBLE **\$29.95**
- EXT-80286 AT COMPATIBLE **\$38.95**
- EXT-15 MICROCHANNEL 6-BIT **\$69.95**
- EXT-32 MICROCHANNEL 32-BIT **\$99.95**



NEW LOW PRICES! SOLDERLESS BREADBOARDS

- PDS-100 1360 TIE PTS **\$12.95**
- PDS-200 1660 TIE PTS **\$19.95**
- PDS-300 2390 TIE PTS **\$24.95**
- PDS-400 3220 TIE PTS **\$34.95**

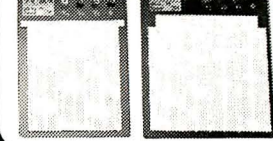

IDC CONNECTORS/RIBBON CABLE

| DESCRIPTION | ORDER BY | CONTACTS | | | | | |
|-----------------------------|----------|----------|------|------|------|------|------|
| | | 10 | 20 | 26 | 34 | 40 | 50 |
| SOLDER HEADER | IDHxxS | .82 | 1.29 | 1.68 | 2.20 | 2.58 | 3.24 |
| RIGHT ANGLE SOLDER HEADER | IDHxxSR | .85 | 1.35 | 1.76 | 2.31 | 2.72 | 3.39 |
| WIREFRAP HEADER | IDHxxW | 1.86 | 2.98 | 3.84 | 4.50 | 5.28 | 6.63 |
| RIGHT ANGLE WIREFRAP HEADER | IDHxxWR | 2.05 | 3.28 | 4.22 | 4.45 | 4.80 | 7.30 |
| RIBBON HEADER SOCKET | IDSxx | .63 | .89 | .95 | 1.29 | 1.49 | 1.69 |
| RIBBON HEADER | IDMxx | -- | 5.50 | 6.25 | 7.00 | 7.50 | 8.50 |
| RIBBON EDGE CARD | IDExx | .85 | 1.25 | 1.35 | 1.75 | 2.05 | 2.45 |
| 10" RIBBON CABLE | RCxx | 1.60 | 3.20 | 4.10 | 5.40 | 6.40 | 7.50 |

FOR ORDERING INSTRUCTIONS, SEE D-SUBMINIATURE CONNECTORS BELOW

RS-232 BREAKOUT BOX

FOR TROUBLESHOOTING SERIAL COMMUNICATIONS

- OPEN/CLOSE INDIVIDUAL CIRCUITS ■ 20 JUMPERS
- CROSS-CONNECT ANY TWO CIRCUITS ■ 10 CIRCUIT ACTIVITY LEDS
- GENER-BO \$34.95**



SURGE SUPPRESSOR

- PROTECTS YOUR EQUIPMENT!
- SIX 3-PRONG AC OUTLETS
 - 15 AMP CIRCUIT BREAKER
 - 6' HEAVY DUTY CORD
 - 15 AMP MAX LOAD, 1875 WATTS
 - UL APPROVED
 - POWER-SURGE \$12.95**
 - POWER-STRIPW/OSURGE \$9.95**



LITHIUM BATTERY

- 6V FOR 286 AND 386 PCS
- MOTHERBOARD CONNECTOR
- ADHESIVE VELCRO MOUNTING STRIP
- LITHIUM 6.8V \$11.95**



- COIN TYPE BATTERY**
 LONG-LASTING 3V LITHIUM
3V-MHW \$1.95
HOLDER \$1.49



PC BREADBOARD

- 62 CLEARLY LABELLED BUS LINES
- ACCEPTS UP TO 24 14-PIN ICs
- 1940 TIE POINTS
- EXT FEMALE DB25 D-SUB CONNECT.
- PDS-604 \$49.95**

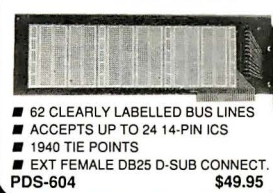

GENDER CHANGERS

- GENDER-FF FEMALE-FEMALE \$7.95**
- GENDER-MM MALE-MALE \$7.95**
- GENDER-MF MALE-FEMALE \$7.95**
- GENDER-NM NULL MODEM \$8.95**
- GENDER-JB JUMPER BOX \$8.95**
- GENDER-MT MINITESTER \$14.95**
- GENDER-VGA DB9-DB15 \$19.95**
- GENDER-9-25 DB9-DB25 \$4.95**

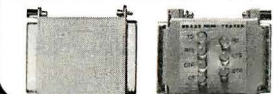

D-SUBMINIATURE CONNECTORS

| DESCRIPTION | ORDER BY | CONTACTS | | | | | | |
|-----------------------|----------|----------|------|------|------|------|------|------|
| | | 9 | 15 | 19 | 25 | 37 | 50 | |
| SOLDER CUP | MALE | DBxxP | .45 | .59 | .69 | .69 | 1.35 | 1.85 |
| | FEMALE | DBxxS | .49 | .69 | .75 | .75 | 1.39 | 2.29 |
| RIGHT ANGLE PC SOLDER | MALE | DBxxPR | .49 | .69 | -- | .79 | 2.27 | -- |
| | FEMALE | DBxxSR | .55 | .75 | -- | .85 | 2.49 | -- |
| WIREFRAP | MALE | DBxxPWW | 1.69 | 2.56 | -- | 3.89 | 5.60 | -- |
| | FEMALE | DBxxSWW | 2.76 | 4.27 | -- | 6.84 | 9.95 | -- |
| IDC RIBBON CABLE | MALE | IDBxxP | 1.39 | 1.99 | -- | 2.25 | 4.25 | -- |
| | FEMALE | IDBxxS | 1.45 | 2.05 | -- | 2.35 | 4.49 | -- |
| HOODS | METAL | MHOODxx | 1.05 | 1.15 | 1.25 | -- | -- | -- |
| | PLASTIC | HOODxx | .39 | .39 | -- | .39 | .69 | .75 |

ORDERING INSTRUCTIONS: INSERT THE NUMBER OF CONTACTS IN THE POSITION MARKED "xx" OF THE "ORDER BY" PART NUMBER LISTED. EXAMPLE: A 15 PIN RIGHT ANGLE MALE PC SOLDER WOULD BE DB15PR

MOUNTING HARDWARE .59

IC SOCKETS/DIP CONNECTORS

| DESCRIPTION | ORDER BY | CONTACTS | | | | | | | | |
|--------------------|-----------|----------|------|------|------|------|------|------|------|------|
| | | 8 | 14 | 16 | 18 | 20 | 22 | 24 | 28 | 40 |
| SOLDERAL SOCKETS | xxST | .11 | .11 | .12 | .15 | .18 | .15 | .20 | .22 | .30 |
| WIREFRAP SOCKETS | xxWW | .59 | .69 | .69 | .99 | 1.09 | 1.39 | 1.49 | 1.69 | 1.99 |
| ZIF SOCKETS | ZIFxx | -- | 4.95 | 4.95 | -- | 5.95 | -- | 5.95 | 6.95 | 9.95 |
| TOOLED SOCKETS | AUGATxxST | .62 | .79 | .89 | 1.09 | 1.29 | 1.39 | 1.49 | 1.69 | 2.49 |
| TOOLED WW SOCKETS | AUGATxxWW | 1.30 | 1.80 | 2.10 | 2.40 | 2.50 | 2.90 | 3.15 | 3.70 | 5.40 |
| COMPONENT CARRIERS | ICCxx | .49 | .59 | .69 | .99 | .99 | .99 | .99 | 1.09 | 1.49 |
| DIP PLUGS (IDC) | IDPxx | .95 | .49 | .59 | 1.29 | 1.49 | -- | .85 | 1.49 | 1.59 |

FOR ORDERING INSTRUCTIONS SEE D-SUBMINIATURE CONNECTORS ABOVE

APPLE-COMPATIBLE PRODUCTS

- FLOPPY DRIVE FOR APPLE II SERIES \$99.95**
- AP-150 (W/CABLE, CONNECTOR) \$99.95**
- REPLACEMENT KEYBOARD FOR APPLE II & II+ \$59.95**
- KEYBOARD-AP \$59.95**
- EPROM PROGRAMMER. NOT REC. FOR CMOS. \$89.95**
- RP-525 (NO POWER SUPPLY REQ.) \$89.95**
- 16K RAM CARD BOOSTS 48K APPLE TO 64K \$39.95**
- RAM-CARD (2 YEAR WARRANTY)**

"SNAPAPART HEADERS"

SNAP APART TO MAKE ANY SIZE HEADER, WITH .1" CENTERS

- 1 X 40 STRAIGHT LEAD .99
- 1 X 40 RIGHT ANGLE LEAD \$1.49
- 2 X 40 STRAIGHT LEAD \$2.49
- 2 X 40 RIGHT ANGLE LEAD \$2.99



JDR MICRODEVICES, 2233 BRANHAM LANE, SAN JOSE, CA 95124
 LOCAL (408) 866-6200 FAX (408) 559-0250 TELEX 171-110
 RETAIL STORE: 1256 S. BASCOM AVE., SAN JOSE, CA
 (408) 947-8881 HOURS: M-F, 9-7 SAT. 9-5 SUN. 12-4



Terms: Minimum order \$10.00. For shipping & handling include \$3.50 for ground and \$4.50 for air. Orders over 1 lb and foreign orders may require additional shipping charges—contact the sales department for the amount. CA residents must include applicable sales tax. Prices subject to change without notice. We are not responsible for typographical errors. We reserve the right to limit quantities and to substitute manufacturer. All merchandise subject to prior sales. A full copy of our terms is available upon request. Items pictured may only be representative.

ORDER TOLL FREE 800-538-5000

COPYRIGHT 1989 JDR MICRODEVICES

CONTINENTAL U.S.



JDR Microdevices

MMC
MICROCOMPUTER
MARKETING COUNCIL
of the Direct Marketing Association, Inc.

• 30 DAY MONEY BACK GUARANTEE • 1 YEAR WARRANTY ON ALL PRODUCTS • TOLL-FREE TECHNICAL SUPPORT
• COMPLETE CUSTOMER SATISFACTION • SUPERIOR SERVICE • FRIENDLY, KNOWLEDGEABLE SALES STAFF



2400 BAUD MODEM

\$99.95

- HAYES COMPATIBILITY ■ 1/2-CARD ■ AUTO DIAL/ANSWER
- SELF-TEST ON POWER UP ■ FULL AND HALF DUPLEX
- TOUCHTONE OR PULSE DIALING ■ 2ND PHONE JACK
- CALL PROGRESS MONITORING ■ ADJUSTABLE VOLUME

PRO-241

INTERNAL MODEMS (MIRROR II SOFTWARE INCLUDED)
 PRO-121 1200 BAUD 1/2 CARD \$69.95
 PRO-24M 2400 BAUD FOR PS/2 \$249.95

EXTERNAL MODEMS REQ. SERIAL PT, CABLE, SOFTWARE
 PRO-24E 2400 BAUD \$169.95
 PRO-12E 1200 BAUD \$99.95

APPLE/MACINTOSH COMPATIBLE MODEMS

EXTERNAL MODEMS, AS ABOVE WITH CABLE & SOFTWARE
 PRO-24EM MAC 2400 BAUD \$199.95
 PRO-24A APPLE II 2400 BAUD \$179.95
 PRO-12A APPLE II 1200 BAUD \$139.95



VGA COMPATIBLE PACKAGE

\$549.95

- 800 X 560 MAXIMUM RESOLUTION
- 640 X 480 IN 16 COLORS
- 320 X 200 IN 256 COLORS
- IBM STYLE MONITOR
- VGA, EGA, CGA, HERCULES, MONOCHROME COMPATIBLE

NEC MULTISYNC II \$599.95

- AUTO FREQ. ADJUSTMENT ■ RESOLUTION TO 800 X 560
- IDEAL FOR CAD, CAM, WINDOWS ■ 9-15 PIN ADAPTER

JDR MULTI \$499.95

- FULL FEATURED MULTISCAN MONITOR WITH UNLIMITED COLORS
- HIGH RESOLUTION, 14" NON-GLARE DISPLAY
- AUTO SWITCHING ■ TTL/ANALOG VIDEO INPUT

JDR-MULTI JDR-MONO 12" MONOCHROME MONITOR \$69.95

EGA MONITOR \$399.95

- 640 X 200/350 RESOLUTION ■ 16 COLOR DISPLAY ■ .31MM DOT PITCH
- 14" BLACK MATRIX SCREEN ■ 9-PIN CABLE

SAVE \$50! EGA CARD & MONITOR \$499

RGB MONITOR \$279.95

- COLOR/GREEN/AMBER SWITCH ■ 41MM DOT PITCH
- 640X200 MONOCHROME RESOLUTION ■ 14" NON-GLARE SCREEN
- ALL HARDWARE, FACEPLATES & SPEAKER

FLAT SCREEN \$139.95

- LOW DISTORTION, 14" GLARE-RESISTANT AMBER SCREEN
- 720 X 350 MAXIMUM RESOLUTION ■ IBM COMPATIBLE TTL INPUT

GM-1488 MONO-SAMSUNG WITH 12" SCREEN \$129.95

TILT & SWIVEL MONITOR STANDS

MS-100 DURABLE PLASTIC \$12.95
 MS-200 WITH SOUTLETS & SURGE SUPPRESSOR \$39.95

HIGH QUALITY KEYBOARDS

101 KEY ENHANCED, W/SEPARATE CURSOR PAD:
 BTC-5339 AUTOSENSE FOR XT/AT, AUTOREPEAT \$79.95
 K103-A AUDIBLE "CLICK" STYLE \$84.95
 MAX-5339 MAXI-SWITCH W/TACTILE FEEDBACK \$84.95

84 KEY STYLES:
 BTC-5060 AUTOSENSE FOR XT/AT \$59.95
 MAX-5060 MAXI-SWITCH W/TACTILE FEEDBACK \$64.95



20 MB \$269



30 MB \$299

KITS INCLUDE A SEAGATE HARD DISK DRIVE, DRIVE CONTROLLER, CABLES AND INSTRUCTIONS.
 HDKIT20 20 MB SYSTEM KIT
 HDKIT30 30 MB SYSTEM KIT

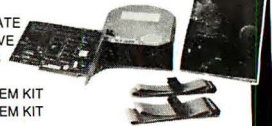

FAST, RELIABLE SEAGATE HARD DISKS:

| DISK SIZE | MODEL | AVG. SPD. | SIZE | PRICE |
|-----------|----------|-----------|--------|-------|
| 20MB | ST-125 | 65 MS | 3-1/2" | \$259 |
| 20MB | ST-225 | 65 MS | 5-1/4" | \$225 |
| 30MB RLL | ST-238 | 65 MS | 5-1/4" | \$249 |
| 40MB | ST-251 | 40 MS | 5-1/4" | \$379 |
| 40MB | ST-251-1 | 28 MS | 5-1/4" | \$469 |
| 60MB RLL | ST-277 | 40 MS | 5-1/4" | \$449 |
| 80MB | ST-4096 | 28 MS | 5-1/4" | \$629 |

1 Mb 3 1/2" DRIVE

\$99.95

- ULTRA HIGH DENSITY
- READ/WRITE 720K DISKS, TOO
- FDD-1.44X BLACK FACEPLATE
- FDD-1.44A BEIGE FACEPLATE
- FDD-1.44 SOFT SOFTWARE DRIVER \$19.95

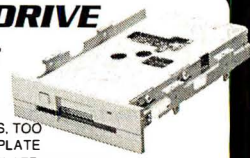

1/2 HEIGHT FLOPPY DISK DRIVES:

FD-55B 5-1/4" TEAC DS/DD 360K \$99.95
 FD-55G 5-1/4" TEAC DS/HD 1.2M \$129.95
 FDD-360 5-1/4" DS/DD 360K \$69.95
 FDD-1.2 5-1/4" DS/HD 1.2M \$95.95
 FDD-3.5X 3-1/2" 720K (BLACK) \$97.95
 FDD-3.5A 3-1/2" 720K (BEIGE) \$97.95

NASHUA DISKETTES (BOXES OF 10):

N-M2D 360K DS/DD \$6.95
 N-M2D BULK (MULTIPLIES OF 50 DISKS) EACH \$4.49
 N-M2H 1.2 MB DS/HD \$13.95
 N-3.5HD 1.44 MB 3-1/2" DS/HD \$49.95
 N-3.5DS 720K 3-1/2" DD/DS \$16.95

TAPE BACK-UP DRIVES & DRIVE ACCESSORIES:

AR5240X ARCHIVE DRIVE XT'S & AT'S \$369.95
 AR5540A FASTER DRIVE-AT'S ONLY \$369.95
 AR340 40 MB TAPE CARTRIDGES \$24.95

FD-ARAIL MTG. RAILS FOR AT COMPATIBLE \$2.95
 FD-55MHV HALF-HT. MOUNTING HARDWARE \$2.95
 FD-5Y Y-POWER ADAPTOR FOR DRIVES \$2.95
 FD55P BEIGE FACEPLATE FOR TEAC DRIVES \$2.95

LOGITECH HIREZ MOUSE

\$89.95

- HIGH RESOLUTION BUS MOUSE FOR BETTER RESPONSE, LESS MOVEMENT
- 320 DPI ■ WITH DRIVER, TEXT EDITOR & POP-UP MENU ■ NO PAD, POWER SUPPLY OR PORT REQUIRED

LMOUSE-BH

LOGITECH 3 BUTTON MOUSE

PC MAGAZINE EDITORS' CHOICE! ALL MODELS HAVE SERIAL SUPPORT (COM1/COM2), 200 D.P.I. RESOLUTION, LOTUS 1-2-3 SHELL, SELF-INSTALLING SOFTWARE AND "POINT EDITOR"

LMOUSE \$74.95
 LMOUSE-P SERIAL MOUSE W/LOGIPAIN \$89.95
 LMOUSE-BP BUS MOUSE W/LOGIPAIN \$89.95
 LMOUSE-BPBL BUS MOUSE W/PUBLISHER PKG \$129.95
 LMOUSE-BPC BUS MOUSE W/LOGIPAIN/CAD \$139.95

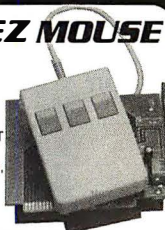

MODULAR PROGRAMMING SYSTEM

OUR INTEGRATED MODULAR PROGRAMMING SYSTEM EASILY EXPANDS! ALL THE MODULES USE A COMMON HOST ADAPTOR CARD, SO YOU CAN USE JUST ONE SLOT TO PROGRAM EPROMS, PROMS, PALS & MORE!

HOST ADAPTOR CARD \$29.95

- UNIVERSAL INTERFACE FOR ALL THE PROGRAMMING MODULES!
- SELECTABLE ADDRESSES PREVENTS CONFLICTS
- HIGH QUALITY MOLDED CABLE

UNIVERSAL MODULE \$499.95

- PROGRAMS EPROMS, EEPROMS, PALS, BI-POLAR PROMS, 8748 & 8751 SERIES DEVICES, 16V8 & 20V8 GALs (GENERIC ARRAY LOGIC) FROM LATTICE, NS, SGS ■ TESTS TTL, CMOS, DYNAMIC & STATIC RAMS ■ LOAD DISK, SAVE DISK, EDIT, BLANK CHECK, PROGRAM, AUTO, READ MASTER, VERIFY & COMPARE
- TEXTUOL SOCKET FOR 3" TO 6" IC'S (8-40 PINS)

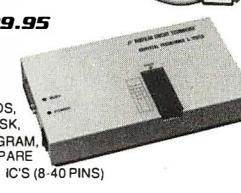
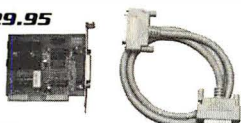

EPROM MODULE \$119.95

- PROGRAMS 24-32 PIN EPROMS, CMOS EPROMS & EEPROMS FROM 16K TO 1024K ■ HEX TO OBJ CONVERTER ■ AUTO. BLANK CHECK/PROGRAM/VERIFY ■ VPP 5, 12.5, 12.75, 13, 21 & 25 VOLTS
- NORMAL, INTELLIGENT, INTERACTIVE, & QUICK PULSE PROGRAMMING ALGORITHMS

MOD-MEP MOD-MEP-4 4-EPROM PROGRAMMER \$169.95
 MOD-MEP-8 8-EPROM PROGRAMMER \$259.95
 MOD-MEP-1616-EPROM PROGRAMMER \$499.95

DIGITAL IC MODULE \$129.95

- TESTS TTL, CMOS, DYNAMIC & STATIC RAM
- AUTO SEARCH FOR UNKNOWN PART NUMBERS
- USER-PROGRAMMABLE TEST PROCEDURES

MOD-MIC

PAL MODULE \$249.95

- PROGRAMS MMI, NS, TI 20 & TI 24 PIN DEVICES
- BLANK CHECK, PROGRAM, AUTO, READMASTER, VERIFY & SECURITY FUSE BLOW

MOD-MPL

PAL PROGRAMMING DEVELOPMENT SOFTWARE
 MOD-MPL-SOFT \$99.95

MOTHERBOARDS

NEW LOW PRICES!

TURBO 4.77/8 MHZ \$95.95

- XT COMPATIBLE ■ NORTON SI 1.7 ■ 4.77 OR 8 MHZ WITH 8088-2 AND OPTIONAL 8087-2 CO-PROCESSOR

10 MHZ SINGLE CHIP \$99.95

- XT COMPATIBLE ■ NORTON SI 2.1 ■ USES LESS POWER ■ KEY-SELECTABLE 4.77 OR 10 MHZ

10 MHZ MINI-286 \$269.95

- AT COMPATIBLE ■ ONLY 8-1/2 X 13" ■ 80286 MICRO-PROCESSOR ■ LANDMARK AT SPEED 15.5 MHZ, NORTON SI 13.8 ■ 6, 10 MHZ; KEYBOARD SELECT

12 MHZ MINI-286 \$299.95

- AT COMPATIBLE ■ ONLY 8-1/2 X 13" ■ 80286 MICRO-PROCESSOR ■ LANDMARK AT SPEED 15.5 MHZ, NORTON SI 13.8 ■ 6, 10, 12 MHZ; KEYBOARD SELECT ■ ZYMOS POACH CHIP SET ■ AWARD BIOS

EPROM PROGRAMMER \$129.95

- PROGRAMS 27XX AND 27XXX EPROMS UP TO 27512
- SUPPORTS VARIOUS PROGRAMMING FORMATS & VOLTAGES ■ SPLIT OR COMBINE CONTENTS OF SEVERAL EPROMS OF DIFFERENT SIZES
- READ, WRITE, COPY, ERASE, CHECK & VERIFY
- SOFTWARE FOR HEX AND INTEL HEX FORMATS

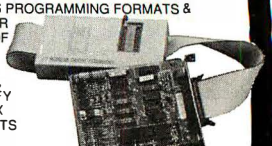

DFI HANDY SCANNER

400 DPI \$199.95

INSTANTLY SCANS UP TO 4.1" W. IMAGES ■ 100, 200, 300, 400 DPI BOTH DIRECTIONS ■ B&W & 3 HALF-TONE MODES ■ 32 LEVELS OF GRAY SCALE ■ HERCULES, CGA, EGA & VGA COMPATIBLE ■ INCLUDES HALO DPE AND IMAGE EDITOR SOFTWARE HS-3000

OCR-SOFT SOFTWARE \$99.95



NEW LOW PRICE!

BUILD YOUR OWN SYSTEM!

OVER 25,000 JDR SYSTEMS HAVE BEEN BUILT.

OUR DETAILED INSTRUCTIONS MAKE IT VERY EASY—ALL YOU NEED IS ABOUT 2 HOURS AND A SCREWDRIVER!



VIDEO INSTRUCTIONS \$4.95 WITH SYSTEM
OUR 20 MINUTE VIDEO SHOWS YOU STEP-BY-STEP HOW TO BUILD AN XT-COMPATIBLE SYSTEM. SPECIFY VHS OR BETA. VIDEO WITH SYSTEM KIT, \$4.95 VIDEO ALONE, 19.95

10 MHz TURBO 8088 SYSTEM \$595.86

SERIAL/PARALLEL PORTS, CLOCK/CALENDAR & GAME ADAPTOR ■ RUNS COLOR GRAPHICS SOFTWARE ON ITS MONOCHROME MONITOR ■ MOTHERBOARD ■ 256K RAM MEMORY ■ 135W POWER SUPPLY ■ FLIPTOP CASE ■ 84 KEY KEYBOARD ■ 360K FLOPPY DRIVE ■ MONOGRAPHS I/O CARD

12 MHz MINI-286 SYSTEM \$1038.47

12 MHz MINI-286 MOTHERBOARD ■ 512K RAM MEMORY ■ MINI-AT CASE W/POWER SUPPLY ■ 84 KEY KEYBOARD ■ MONOCHROME MONITOR ■ 1.2 MB FLOPPY DRIVE ■ FLOPPY/HARD CONTROL ■ MONOGRAPHS CARD

EPSON PRICES SO LOW, WE CAN'T PRINT THEM!

JDR CARRIES A FULL LINE OF QUALITY EPSON PRINTERS. WE CAN'T ADVERTISE OUR LOW PRICES—CALL OUR SALES DEPARTMENT FOR A PRICE QUOTE TODAY: 1-800-538-5000 TOLL-FREE!

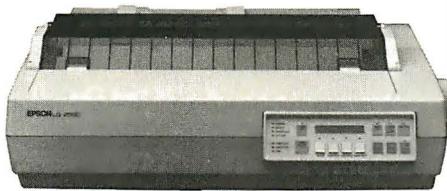

EPSON LQ-2550 CALL FOR THE PRICE!
(SHOWN) ■ 132-COLUMN CARRIAGE, SUPER FAST OUTPUT! ■ 24-PIN PRINT HEAD, 8K MEMORY BUFFER ■ 400 CPS DRAFT, 133 CPS LO ■ PRINTS UP TO 7 COLORS ■ SEVEN FONTS ■ PARALLEL & SERIAL INTERFACES

EPSON LQ-950 CALL FOR THE PRICE!
■ 24-PIN PRINT HEAD, 6K MEMORY BUFFER ■ 110-COL. CARRIAGE ■ 264 CPS DRAFT, 88 CPS LO ■ 360 X 360 DPI GRAPHICS RESOL. ■ PARALLEL AND SERIAL INTERFACES

EPSON LQ-850 CALL FOR THE PRICE!
■ 24-PIN PRINT HEAD, 6K MEMORY BUFFER ■ 80-COL. CARRIAGE ■ 264 CPS DRAFT, 88 CPS LO ■ BIDIRECTIONAL TEXT & GRAPHICS ■ PARALLEL AND SERIAL INTERFACES

EPSON LQ-500 CALL FOR THE PRICE!
■ 24-PIN PRINT HEAD, 8K MEMORY BUFFER ■ 80-COL. CARRIAGE ■ 180 CPS DRAFT, 88 CPS LO ■ BIDIRECTIONAL TEXT & GRAPHICS ■ PARALLEL INTERFACE (SERIAL OPT.)

EPSON FX-850 CALL FOR THE PRICE!
FOR FORMS, ENVELOPES, FANFOLDS! ■ 80-COL. CARRIAGE ■ 264 CPS DRAFT, 54 CPS NLQ ■ 9-PIN PRINT HEAD, 8K MEMORY BUFFER ■ AUTO LOAD ■ PARALLEL INTERFACE FX-1050 WITH 136-COLUMN CARRIAGE \$CALL!

EPSON EX-800 CALL FOR THE PRICE!
■ 9-PIN PRINT HEAD, 8K MEMORY BUFFER ■ 80-COLUMN CARRIAGE ■ 300 CPS DRAFT, 50 CPS NLQ ■ BIDIRECTIONAL TEXT MODE ■ PARALLEL & SERIAL INTERFACES

EPSON LX-800 CALL FOR THE PRICE!
■ 9-PIN DOT MATRIX PRINT HEAD, 3K MEMORY BUFFER ■ 80-COL. CARRIAGE ■ 180 CPS DRAFT, 30 CPS NLQ MODE ■ PARALLEL INTERFACE (SERIAL OPTIONAL.)

24-HR. ON-LINE ORDERING!
(408) 559-0253

JDR'S ELECTRONIC BULLETIN BOARD OFFERS TECHNICAL SUPPORT, CONFERENCING AND MORE

CALL FOR A FREE COPY OF OUR
84-PG CATALOG

IT'S OUR 10TH ANNIVERSARY EDITION
— FILLED WITH GREAT VALUES!

BARGAIN HUNTERS' CORNER
SAVE \$40
20 MHz DUAL-TRACE OSCILLOSCOPE

REGULARLY \$389.95
■ FAST FREQUENCY AND PHASE MEASUREMENT
■ TV SYNC CIRCUITS TO VIEW TV-V AND TV-H
■ ACCURATE SYNCHRONIZATION OF VIDEO SIGNAL, BLANKING, VITS, AND VH SYNC PULSES
■ COMPONENT TESTER ■ BRIGHT 5-INCH CRT
■ X-Y OPERATION 110/120V ■ 2 YEAR WARRANTY MODEL 2000 OFFER EXPIRES 5/31/89

\$349.95

INTERFACE CARDS ■ MODULAR CIRCUIT TECHNOLOGY

DISPLAY ADAPTORS

MONOCHROME GRAPHICS \$59.95
■ HERCULES COMPAT. SUPPORTS LOTUS 1-2-3 ■ VLSI CHIPS ■ PARALLEL PRINTER PORT CONFIG. AS LPT1 OR 2 MCT-MGP

COLOR GRAPHICS ADAPTOR \$49.95
■ IBM COMPATIBLE ■ FOR RGB, COLOR AND COMPOSITE MONO ■ 640/320 X 200 RESOLUTION WITH LIGHT PEN INTERFACE MCT-CG

ENHANCED GRAPHICS ADAPTOR \$149.95
■ IBM COMPATIBLE, PASSES IBM EGA DIAGNOSTICS ■ 256K OF VIDEO RAM FOR 640 X 350 IN 16 OF 64 COLORS ■ HERCULES COMPATIBLE MCT-EGA

MONOGRAPHS MULTI I/O \$119.75
■ CONTROL 2 FLOPPIES, SERIAL, PARALLEL, GAME PORT, CAL CLOCK ■ RUN COLOR GRAPHICS SOFTWARE ON YOUR MONOCHROME MONITOR MCT-MGMI0

286/386 MONOGRAPHS I/O \$99.95
■ HOOK UP A MONOCHROME MONITOR, PARALLEL PRINTER, MODEM AND JOYSTICK ALL AT ONCE! ■ ONLY OTHER CARD YOUR SYSTEM NEEDS IS A FLOPPY/HARD CONTROLLER ■ AT COMPATIBLE ■ 720 X 348 RESOLUTION, 80 & 132 COLUMN TEXT ■ PARALLEL, SERIAL AND GAME PORTS ■ HERCULES COMPATIBLE MONOGRAPHS ■ WITH SOFTWARE TO RUN COLOR GRAPHICS ON A MONOCHROME MONITOR MCT-MGAIO



DRIVE CONTROLLERS

FLOPPY/HARD CONTROLLER \$139.95
■ FREES 1 SLOT IN YOUR XT SYSTEM ■ INTERFACES 2 FDD'S AND 2 HDD'S; CABLING FOR 2 FDD, 1 HDD MCT-FH (SHOWN)

FLOPPY DISK CONTROLLER \$29.95
■ 1 SLOT CONTROL OF 4 FLOPPIES ■ INTERFACES UP TO 4 FDD'S TO IBM PC OR COMPATIBLE ■ DS/DD & DS/QD MCT-FDC

1.2 MB FLOPPY CONTROLLER \$49.95
■ SUPPORTS 2 DRIVES, CAN MIX 360K AND 1.2MB ■ LETS DATA FLOW FREELY FROM XT'S TO AT'S MCT-FDC-1.2

HARD DISK CONTROLLER \$79.95
■ SUPPORTS 16 DRIVE SIZES, INCLUDING 10, 20, 30, 40 MB ■ DIVIDES 1 LARGE DRIVE INTO TWO LOGICAL DRIVES MCT-HDC

RLI CONTROLLER \$89.95
■ TRANSFERS DATA 50% FASTER! ■ SUPPORTS UP TO 2 RLL HARD DRIVES ■ FOR XT COMPATIBLES MCT-RLI

286/386 FLOPPY/HARD \$149.95
■ TRUE AT DESIGN ■ SUPPORTS UP TO TWO 360K/720K/1.2MB/1.44MB FDD'S ■ SUPPORTS 2 HDD'S (STD. TABLES) MCT-AFH

286/386 RLL CONTROLLER \$199.95
■ SUPPORTS UP TO 2 RLL HARD DRIVES AND 2 FLOPPIES ■ SUPPORTS 360/720/1.2/1.44 MB FLOPPIES (5-1/2" & 3-1/2") MCT-AFH-RLL

MULTIFUNCTION CARDS

MULTI I/O FLOPPY CONTROLLER \$79.95
■ SUPPORTS UP TO 2 360K FLOPPIES, 720K W/ DOS 3.2 ■ SERIAL, PARALLEL, GAME PORT, CLOCK/CALENDAR MCT-MIO

MULTI I/O CARD \$59.95
■ SERIAL PORT, CLOCK/CALENDAR W/BATTERY ■ PARA: LEL PORT IS ADDRESSABLE AS LPT1 OR LPT2 MCT-IO

286/386 MULTIFUNCTION \$139.95
■ ADDS 1.5MB (3 MB WITH OPTIONAL PIGGYBACK CARD, OK INSTALLED) TO YOUR AT ■ INCLUDES SERIAL AND PARALLEL PORTS

MCT-AMF \$29.95
MCT-AMF-MC 1.5MB PIGGYBACK BOARD \$29.95
AIO-SERIAL 2ND SERIAL PORT \$24.95

286/386 MULTI I/O CARD \$59.95
■ SERIAL, PARALLEL AND GAME PORTS ■ USES 16450 SERIAL SUPPORT CHIPS FOR HIGH SPEED OPERATION MCT-AIO

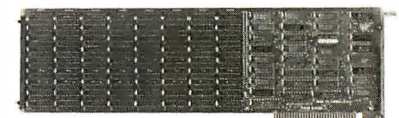

MEMORY CARDS

576K RAM CARD \$59.95
■ SHORT SLOT ■ USER SELECTABLE CONFIGURATION TO 576K ■ 64K AND 256K RAM CHIPS (OK INSTALLED) MCT-RAM

EXPANDED MEMORY CARD \$129.95
■ 2MB LM MEMORY (OK INSTALLED) ■ USER EXPANDABLE TO 2 MB ■ CONFORMS TO LOTUS INTEL EMS MCT-EMS (SHOWN)
MCT-AEMS 286/386 EMS CARD \$139.95



JDR MICRODEVICES, 2233 BRANHAM LANE, SAN JOSE, CA 95124
LOCAL (408) 866-6200 FAX (408) 559-0250 TELEX 171-110

RETAIL STORE: 1256 S. BASCOM AVE., SAN JOSE, CA
(408) 947-8881 HOURS: M-F, 9-7 SAT. 9-5 SUN. 12-4

NEW ADDRESS!

Terms: Minimum order \$10.00. For shipping & handling include \$3.50 for ground and \$4.50 for air. Orders over 1 lb and foreign orders may require additional shipping charges—please contact the sales department for the amount. CA residents must include applicable sales tax. Prices subject to change without notice. We are not responsible for typographical errors. We reserve the right to limit quantities and to substitute manufacturer. All merchandise subject to prior sales. A full copy of our terms is available upon request. Items pictured may only be representative.

MMC ORDER TOLL FREE 800-538-5000

COPYRIGHT 1989 JDR MICRODEVICES

CONTINENTAL US

EDITORIAL INDEX BY COMPANY

Index of companies covered in articles, columns, or news stories in this issue
Each reference is to the first page of the article or section in which the company name appears

| INQUIRY # | COMPANY | PAGE | INQUIRY # | COMPANY | PAGE | INQUIRY # | COMPANY | PAGE |
|-----------|----------------------------|--------------------|-----------|----------------------------|----------------------------|-----------|----------------------------|-------------------|
| 853 | ABATON | 208 | 1121 | CSE | 80 | 1131 | JASMINE TECHNOLOGIES | 65 |
| | ABSFT | 11 | | CYPRESS | 11 | 1141 | | |
| 1138 | ADAC | 65 | | DATA GENERAL | 11, 113, 227 | 883 | JENSEN & PARTNERS | |
| | ADDISON-WESLEY | 11 | | DAVID SARNOFF RESEARCH | | | INTERNATIONAL | 211 |
| 1142 | ADVANCED DIGITAL | | | CENTER | 283 | | JOHN WILEY & SONS | 51, 237 |
| | INFORMATION | 65 | 1136 | DEFINICON SYSTEMS | 65 | | JOHNS HOPKINS UNIVERSITY | 268 |
| 1105 | ADVANCED GRAPHICS | | 1152 | DEVELOPMENT ASSOCIATES | 65 | 1130 | KEY TRONIC | 65 |
| | SOFTWARE | 80 | 1150 | DIGITAL COMMUNICATIONS | | 1023 | KURTA | 143 |
| | ADVANCED LOGIC RESEARCH | 11 | | ASSOCIATES | 65 | | | |
| 1106 | ALLAN BONADIO ASSOCIATES | 80 | 1002 | DIGITAL EQUIPMENT | | 1151 | LAZARUS DATA PRODUCTS | 65 |
| | AMD | 113 | | | 11, 227, 245, 266 | | LEGO | 11 |
| 1126 | AMERICAN COMPUTER SECURITY | | 1037 | DISTRIBUTED PROCESSING | | 994 | LOCUS COMPUTING | 227, 266 |
| | INDUSTRIES | 65 | | TECHNOLOGY | 123 | 983 | LOTUS DEVELOPMENT | 97, 151 |
| 1045 | AMERICAN SMALL BUSINESS | | 981 | DIVERSIFIED COMPUTER | | 1025 | | |
| | COMPUTER | 178 | | SYSTEMS | 151 | | LSI LOGIC | 11 |
| 990 | APOLLO COMPUTER | 266 | 1125 | DOLCH COMPUTER SYSTEMS | 65 | 1112 | MACCULLOCH, PRYMAK | 80 |
| 854 | APPLE | | | DOUBLEDAY | 268 | 1137 | MATROX ELECTRONICS | |
| 989 | COMPUTER | 11, 117, 208, 266 | 1043 | DTG | 123 | | SYSTEMS | 65 |
| 1038 | APPLIED CREATIVE | | | ENIGMA LOGIC | 253 | | MCGRAW-HILL | 237 |
| | TECHNOLOGY | 123 | 1111 | ERIC ISAACSON SOFTWARE | 80 | 1053 | MEGA CADD | 178 |
| 1102 | ASHTON-TATE | 11, 157 | 991 | EVEREX SYSTEMS | 113, 266 | 1129 | METARESEARCH | 65 |
| | ASSOCIATION FOR COMPUTING | | 1050 | EVOLUTION COMPUTING | 178 | 995 | MICROPORT SYSTEMS | 266 |
| | MACHINERY | 11 | 1072 | FARALLON COMPUTING | 171 | 1040 | MICROSOFT | 11, 123, 227 |
| 987 | AT&T INFORMATION SYSTEMS | 113, 227, 253, 266 | 982 | FOX SOFTWARE | 151 | | MICROSOFT PRESS | 51 |
| | | | | FRAME TECHNOLOGY | 11 | 1054 | MICROTECTURE | 178 |
| 1046 | AUTODESK | 178 | 1148 | FREDERICK ENGINEERING | 65 | 1022 | MINDSCAPE | 143 |
| 1073 | AVATAR | 171 | | FREE SOFTWARE | | 1030 | MINNOW BEAR COMPUTERS | 123 |
| | | | | FOUNDATION | 227 | | MIPS COMPUTER | |
| 1143 | BANYAN SYSTEMS | 65 | 1021 | FUJITSU MICROELECTRONICS | 11 | | SYSTEMS | 11, 227 |
| 1113 | BECKMAN ASSOCIATES | 80 | | FUNK SOFTWARE | 143 | 1108 | MMC AD SYSTEMS | 80 |
| | BELL LABORATORIES | 245, 275 | | GARTNER GROUP | 11 | | MORTICE KERN SYSTEMS | 237 |
| 1103 | BINARY ENGINEERING | 80 | 1109 | GENUS | | | MOSAIC MARKETING | 80 |
| | BIPOLAR INTEGRATED | | | MICROPROGRAMMING | 80 | 984 | MOSAIC SOFTWARE | 151 |
| | TECHNOLOGY | 11 | 1144 | GRAPHIC SOFTWARE | | | MOTOROLA | 11, 113, 227, 245 |
| 1024 | BOLT SYSTEMS | 97, 163 | | SYSTEMS | 65 | 993 | MT XINU | 266 |
| 1028 | | | 1110 | GUIDELINES SOFTWARE | 80 | 1104 | MTR SOFTWARE | 80 |
| 1116 | BOWLING GREEN STATE | | | | | | NATIONAL COMPUTER SECURITY | |
| | UNIVERSITY | 80 | 1039 | HAMMERLY COMPUTER | | | CENTER | 253 |
| | BURNDY | 11 | | SERVICES | 123 | | NATIONAL INSTITUTE OF | |
| | | | | HAYDEN BOOKS | 237 | | STANDARDS AND | |
| 1047 | CADKEY | 178 | 992 | HEWLETT-PACKARD | | | TECHNOLOGY | 11 |
| 855 | CAERE | 203 | 1123 | | 11, 65, 245, 266 | | NATIONAL SEMICONDUCTOR | 11 |
| 856 | CALERA RECOGNITION | | 1132 | HITACHI | 11 | | NCR | 245 |
| | SYSTEMS | 203 | | HOWARD W. SAMS | 253 | | NEC | 11 |
| 1146 | CASTELLE | 65 | | | | | NORSK DATA | 11 |
| 1155 | CBIS | 65 | 988 | IBM | 11, 65, 227, 245, 266, 275 | 1140 | NOVELL | 65 |
| 1147 | CC:MAIL | 65 | 1128 | | | | OLIVETTI | 11, 113 |
| | CENTER FOR COMPLEX SYSTEM | | 1153 | IN FOCUS SYSTEMS | 65 | 1032 | ONTRACK COMPUTER | |
| | RESEARCH | 11 | | INFORMIX | 11 | | SYSTEMS | 123 |
| 1031 | CHEETAH INTERNATIONAL | 123 | 1004 | INSIGNIA SOLUTIONS | 11 | | OPEN SOFTWARE | |
| 1119 | CLARIS | 80 | | INTEL | 11, 113, 227, 266 | | FOUNDATION | 227 |
| | CLEARPOINT RESEARCH | 11 | 1006 | INTERACTIVE SYSTEMS | 266 | 997 | OPUS SYSTEMS | 65, 113, 266 |
| 1027 | COMPAQ COMPUTER | 11, 97 | 1051 | INTERGRAPH | 178 | 1124 | | |
| 1114 | COMPUTER ASSOCIATES | | | INTERNATIONAL ORGANIZATION | | | OPUS/EVEREX | 11 |
| | INTERNATIONAL | 80 | | OF STANDARDS | 11 | | | |
| 1048 | COMPUTER RESOURCE | | 1145 | INTERPRETER | 65 | 1044 | P.C. POWER & COOLING | 123 |
| | TECHNOLOGY | 178 | 1052 | ISICAD | 178 | 1154 | PACIFIC DATA PRODUCTS | 65 |
| 999 | CONCURRENT COMPUTER | 266 | | | | 1101 | PARAGON CONCEPTS | 157 |
| 1026 | CONNECTIX | 97 | | | | | | |
| 1033 | CONSUMERS SOFTWARE | 123 | | | | | | |
| 1049 | CONTROL AUTOMATION | 178 | | | | | | |
| 1041 | CRESCENT SOFTWARE | 123 | | | | | | |

COMING UP IN BYTE

PRODUCTS IN PERSPECTIVE:

The front of BYTE will feature, as always, Microbytes, What's New, and Short Takes. The June Short Takes, BYTE's hands-on look at new and interesting products in an abbreviated format, will include Dell Computer's 325, Lifetree's Volkswriter 4, Digital Vision's ComputerEyes image digitizer, and DTG's System Sleuth, among others.

How much modem can you get for under \$500? In June's **Product Focus**, we examine inexpensive external 2400-bps modems that support V.22bis and MNP 5 data compression.

System reviews begin with a new 80386SX computer: the NCR PC916sx. Apple's new Macintosh SE/30 promises to be an exciting machine. In June, we follow up our February preview coverage with an in-depth review of the system.

Add-in/peripheral reviews look at four high-resolution hand scanners: Logitech's ScanMan, The Complete PC's Complete Hand Scanner, DFEI's HS-3000, and KYE International's Geniescan. We also compare six 16-bit VGA cards: ATI's VGA Wonder, Genoa's Model 5400, Orchid's Prodesigner Plus, STB's VGA EM-16, and Video Seven's V-RAM VGA and FastWrite VGA.

In our **language reviews**, we'll look at Smalltalk/V Mac, a robust and mature product based on object-oriented technology that Digitalk has been developing for years.

Another **review** will cover a tool for constructing skeletal Windows applications. CASE:W is itself a Windows application that manages menus, resource script files, icons, and dialog boxes in a WYSIWYG context.

Application reviews include design and drawing programs. Claris CAD for the Mac looks to be a power-packed two-dimensional CAD program. On the PC side, Corel Systems' Corel Draw is a high-end drawing program that shows promise.

IN DEPTH:

The **security of sensitive data** is a major area of concern in the computer world—one very much in the public eye with the now-famous nationwide network worm. Our coverage will include different methods of securing network access, data encryption, radiation protection, and more. Protective devices will also be discussed.

FEATURES:

Our **Expert Advice** columnists will hold forth at the front of the book: Jerry Pournelle, Ezra Shapiro, Wayne Rash, Mark L. Van Name, Bill Catchings, Tom Thompson, and Mark Minasi. We'll also have our two **Hands On** columnists. In *Some Assembly Required*, Rick Grehan will continue his tour of operating systems and how they handle file directories. Brett Glass will look *Under the Hood* at new modem technology.

In our **full-length features**, we'll discuss methods for turning a single-user application into a multiuser application for running on a LAN. Based on an actual case study, the article presents the pitfalls of network programming. Standard DOS applications are limited to 640K bytes. The LIM/EEMS specification gives computers access to as much as 32 megabytes of additional memory. We'll present a library of C programs that uses the specification to make expanded memory available for data storage.

| INQUIRY # | COMPANY | PAGE |
|-----------|---------------------------------|--------------------|
| 1036 | PETER NORTON COMPUTING | 123 |
| | PHOENIX TECHNOLOGIES | 11 |
| 1133 | POLYWELL | 65 |
| 996 | PRENTICE-HALL | 51, 266 |
| 1029 | PRIME SOLUTIONS | 97 |
| 854 | PSION | 195 |
| | PYRAMID TECHNOLOGY | 227 |
| 998 | QUANTUM SOFTWARE SYSTEMS | 266 |
| 1149 | RACAL-VADIC | 65 |
| | RAINBOW TECHNOLOGIES | 11 |
| 1035 | ROBERTA J. POURNELLE | 123 |
| 882 | SAMNA | 221 |
| 985 | SANTA CRUZ OPERATION | |
| 1005 | | 151, 227, 266 |
| | SANYO/ICON | 11 |
| 1055 | SCHROFF DEVELOPMENT | 178 |
| 1135 | SCION | 65 |
| | SEAGATE | 11 |
| 853 | SHARP ELECTRONICS | 195 |
| 1074 | SHIVA | 171 |
| | SILICON GRAPHICS | 113 |
| | SOLID-STATE CIRCUITS CONFERENCE | 11 |
| | STANFORD LINEAR ACCELERATOR | 11 |
| | STANFORD UNIVERSITY | 11 |
| 881 | SHERLING CASTLE | 217 |
| 855 | STF TECHNOLOGIES | 208 |
| 1042 | STORAGE DIMENSIONS | 123 |
| 1000 | SUN MICROSYSTEMS | |
| | | 108, 113, 227, 266 |
| | SYRACUSE UNIVERSITY | 268 |
| | SYTEK | 253 |
| | TANDY | 11 |
| 1001 | TEXASINSTRUMENTS | |
| | | 11, 266, 283 |
| 1071 | 3COM | 171 |
| 1118 | TIMBERLINE SOFTWARE | 80 |
| | TOSHIBA | 11 |
| | UNISOLUTIONS ASSOCIATES | 253 |
| | UNISYS | 245 |
| | UNITED SOFTWARE | 253 |
| | UNIVERSITY OF ILLINOIS | 275 |
| 1003 | VENTURCOM | 266 |
| 1056 | VERSACAD | 80, 178 |
| 1120 | | |
| 986 | WORDPERFECT | 151 |
| 1034 | WORKMAN & ASSOCIATES | 123 |
| 854 | XEC PRODUCTS | 195 |
| | XEROX PALO ALTO RESEARCH CENTER | 11 |
| | X3J3 | 11 |
| | ZENITH DATA SYSTEMS | 11 |

READER SERVICE

To get further information on the products advertised in BYTE, fill out the reader service card by circling the numbers on the card that correspond to the inquiry number listed with the advertiser. This index is provided as an additional service by the publisher, who assumes no liability for errors or omissions.

* Correspond directly with company.

Alphabetical Index to Advertisers

| Inquiry No. | Page No. | Inquiry No. | Page No. | Inquiry No. | Page No. | Inquiry No. | Page No. | |
|-------------|-----------------------------|-------------|----------|-----------------------------|----------|-------------|-------------------------|---------|
| 8 | 2001 SALES | 198 | 80 | DIGIBOARD | 240 | 167 | MATRIX | 116 |
| 9 | 2001 SALES | 198 | 81 | DIGIBOARD | 241 | * | MAXELL CORP. OF AMERICA | 73 |
| 10 | 2500 AD SOFTWARE | 242 | 82 | DIGITAL RESEARCH | 50 | 170 | MAXON | 95 |
| 11 | ABRAXAS SOFTWARE | 258 | 83 | DIGITAL RESEARCH | 50 | 171 | MAXON | 95 |
| * | ADOBE | 115 | 85 | DISKCO TECH | 326 | * | MCGRAW-HILL NRI | 96C1-2 |
| 17 | ADVANCED LOGIC RES. | 76,77 | 86 | DISKETTE CONNECTION | 323 | 172 | MEAD COMPUTER | 333 |
| 18 | ADVANCED LOGIC RES. | 76,77 | 87 | DIVERSIFIED COMPUTER SYS. | 324 | 302 | MEGA DRIVE | 85 |
| 32 | ADVANCED MATRIX TECH | 209 | 88 | DSP | 24 | 303 | MEGA DRIVE | 85 |
| 12 | ADVANCED MICRO RES. | 259 | 89 | DYNAMIC ELECTRONICS | 324 | 173 | MEGASOFT | 330 |
| 13 | ADVANTAGE SOFTWARE | 255 | 90 | ECOSOFT | 20 | 174 | MEGATEL | 86 |
| 14 | AGRANAT | 126 | 91 | EDC | 320 | 175 | MERRITT COMPUTER PROD. | 278 |
| 15 | AK SYSTEMS | 332 | 93 | ELEXOR INC | 58 | 176 | MICRO TELESIS | 44 |
| * | ALCYON | 155 | 94 | ELLIS COMPUTING | 214 | 309 | MICROCOM | 260 |
| 16 | ALPHA PRODUCTS COMPANY | 327 | 95 | EMERSON | 94 | 177 | MICROPROCESSORS UNLTD. | 330 |
| 19 | ALTEX ELECTRONICS | 319 | 100 | ENGINEERS COLLABORATIVE | 320 | * | MICROSOFT | 13 |
| 20 | AMERICAN SMALL BUS. COMP. | 132 | 101 | EOTRON CORP. | 34 | 178 | MICROSOFT PRESS | 162 |
| * | AMPRO | 130 | 102 | EOTRON CORP. | 34 | 179 | MICROTECH | 330 |
| 21 | AMS | 330 | 103 | EXECUTIVE PHOTO & SUPPLY | 208B | * | MICROWAY | 41 |
| 23 | ANNABOOKS | 314 | 104 | E-TECH RESEARCH | 332 | 180 | MICROWAY | 207 |
| * | ANTHRO | 26 | 96 | FLAGSTAFF | 122 | 181 | MIRO DATENSYTTME | 166 |
| 24 | APPLIED PROG. ELECT. | 328,329 | 97 | FLAGSTAFF | 122 | 182 | MIX SOFTWARE | 141 |
| 25 | AST RESEARCH | 197 | 98 | FLAGSTAFF | 122 | 183 | MIX SOFTWARE | 295 |
| 26 | AST RESEARCH | 197 | 99 | FLAGSTAFF | 122 | 184 | MKS | 252 |
| 27 | ATI TECHNOLOGIES | 159 | 105 | FORESIGHT RESOURCES | 181 | * | MONTGOMERY GRANT | 156 |
| 28 | ATRON | 64 | 106 | FORESIGHT RESOURCES | 181 | 313 | NATIONAL INSTRUMENTS | CIII |
| 29 | AVOCET SYSTEMS | 59 | * | FORTE COMMUNICATIONS | 84 | 314 | NATIONAL INSTRUMENTS | CIII |
| 30 | AVOCET & QUELO | 324 | 107 | FORTRON | 46 | 186 | NATURAL MICROSYSTEMS | 146 |
| 31 | A.C.P. | 337 | 108 | FOX SOFTWARE | 25 | * | NEC HOME ELECT. | 36,37 |
| 33 | A.N. WHOLESALE & RETAIL | 330 | 109 | FTG DATA SYSTEMS | 320 | * | NEC HOME ELECT. | 56,57 |
| 34 | B P MICROSYSTEMS | 330 | 110 | FUJITSU | 14,15 | 188 | NEEDHAM'S ELECTRONICS | 316 |
| 35 | B & B ELECTRONICS | 323 | 111 | FUJITSU | 14,15 | 189 | NETWORK TECH. INC. | 323 |
| 36 | B & C MICRO | 325 | 112 | FUTURE COMPUTER SYS. | 101 | 304 | NEW GENERATION SYSTEMS | 318 |
| 37 | B & C MICRO | 325 | 113 | FUTURE COMPUTER SYS. | 101 | 190 | NITRO MICRO | 175 |
| 38 | BASF | 208E | 114 | GATEWAY 2000 | 8,9 | 312 | NORTON LAMBERT | 21 |
| 39 | BAY TECH | 103 | 115 | GEN. PARAMETRICS CORP. | 165 | 192 | OKIDATA | 55 |
| 40 | BAY TECH | 103 | 116 | GENERIC SOFTWARE | 187 | 193 | ON TARGET ASSOCIATES | 326 |
| 42 | BEST COMPUTER | 134 | 117 | GENERIC SOFTWARE | 187 | 194 | ON-LINE STORE | 210 |
| 43 | BEST COMPUTER | 134 | 118 | GENICOM | 88,89 | * | ORACLE | 75 |
| 44 | BINARY ENGINEERING | 200 | 305 | GENOA SYSTEMS CORP. | 79 | 195 | OST | 42 |
| 45 | BINARY TECHNOLOGY | 320 | 120 | GOLDEN BOW | 124 | 196 | OVERLAND DATA | 102 |
| * | BIX | 278 | 121 | GOLDEN BOW | 124 | * | P C EXPO | 290 |
| * | BIX | 311 | 122 | G-TEK | 96 | 197 | PACIFIC COMPUTER | 315 |
| 450 | BIX | 176,177 | 123 | G-TEK | 96 | 198 | PACIFIC COMPUTER | 315 |
| 47 | BLAISE COMPUTING | 45 | 124 | HAMMERLY COMPUTER SERV. | 33 | 199 | PALLADIAN TECHNOLOGIES | 326 |
| 48 | BOLTSYSTEMS | 54 | 125 | HARRIS/3M | 182,183 | 200 | PARA SYSTEMS | 87 |
| 49 | BORLAND | 69 | 126 | HEWLETT-PACKARD PERIPH. | 92,93 | 201 | PARC PLACE SYSTEMS | 119 |
| 50 | BORLAND | 69 | 127 | HIGH RES TECHNOLOGIES | 330 | 202 | PATTON & PATTON | 128 |
| * | BUYER'S MART | 300-311 | 128 | HI-TECH EQUIP. CORP. | 320 | 203 | PAUL MACE SOFTWARE | 164 |
| * | BYTE BACK ISSUES | 314 | 129 | HORSTMANN SOFTWARE | 289 | 204 | PERISCOPE CO. | 243 |
| 310 | BYTE BITS | 316,332 | 130 | HOUSTON INSTRUMENT | 191 | 205 | PERISCOPE CO. | 243 |
| * | BYTEBOOK CLUB | 160,161 | * | IBM | 208A | 191 | PERSONAL SPACE COMM. | 318 |
| * | BYTE SUB. MESSAGE | 219 | 131 | IC EXPRESS | 323 | 206 | PERSONAL TEX | 220 |
| * | BYTE SUB. SERVICE | 256 | 132 | IMAGINE THAT! | 118 | 207 | PETER NORTON | 215 |
| 51 | BYTEK COMPUTER CORP. | 320 | 133 | IMPACT COMPUTER SYSTEMS | 102 | 208 | PETER NORTON | 215 |
| * | BYTEWEEK/NEWSLETTER | 214 | | INTEGRA, INC. | 318 | 218 | PI COMPUTER CORP. | 213 |
| * | BYTEWEEK/NEWSLETTER | 282 | 134 | INTEGRAND | 40 | 219 | PI COMPUTER CORP. | 213 |
| 52 | CAD SOFTWARE | 60 | 135 | INTERACTIVE SYSTEMS | 7 | 209 | POCKETSOFT | 35 |
| 53 | CAD WAREHOUSE | 192 | 136 | INTERACTIVE SYSTEMS | 7 | 307 | POLYTRON | 267 |
| 54 | CADRE TECHNOLOGIES | 264 | 137 | IO TECH | 249 | 210 | PRIME SOLUTIONS | 199 |
| 55 | CALCOMP | 170 | 138 | IO TECH | 318 | 211 | PRIME SOLUTIONS | 199 |
| * | CALIFORNIA DIGITAL | 317 | 139 | JADE | 335 | 212 | PROGRAMMERS PARADISE | 62,63 |
| 56 | CAPITAL EQUIPMENT | 154 | 140 | JAMECO | 320A-H | 213 | PROGRAMMERS SHOP | 126 |
| 308 | CENTURY DATA | 274 | 140 | JAMECO | 321,322 | 214 | PROTECH MARKETING | 54 |
| 306 | CHIP FACTORY | 154 | 141 | JENSEN & PARTNERS INC | 125 | 215 | PROTECH MARKETING | 54 |
| 22 | CLONE COMPUTER | 312,313 | 142 | JYACC, INC. | 233 | 216 | PROTEUS TECHNOLOGY CORP | 27 |
| * | COMPACT DISK PRODUCTS | 277 | 6 | J.D.R. | 338-341 | 217 | PUNCTUM | 316 |
| * | COMPAQ | 82,83 | 7 | J.D.R. | 338-341 | 220 | QUALSTAR CORP. | 326 |
| 57 | COMPUCLASSICS | 244 | 143 | KADAK | 60 | 221 | QUANTUM SOFTWARE | 229 |
| 58 | COMPUCOM | 314 | 144 | KEA SYSTEMS | 239 | 222 | QUARTERDECK | 148,149 |
| 59 | COMPUSAVE | 315 | 145 | KNOWLEDGE GARDEN | 208G | 223 | QUARTERDECK | 148,149 |
| 60 | COMPUTER AGE LTD. | 323 | 146 | KORE, INC. | 324 | 224 | QUARTERDECK | 148,149 |
| 61 | COMPUTER ASSOCIATES | 70,71 | 147 | LA COMPUTER | 331 | 225 | QUARTERDECK | 148,149 |
| 62 | COMPUTER MAIL ORDER | 48,49 | 148 | LAHEY COMPUTER SYSTEMS | 133 | 226 | QUATECH | 316 |
| 63 | COMPUTER PROF. BOOKS | 129 | 149 | LAHEY COMPUTER SYSTEMS | 135 | 227 | QUATECH | 316 |
| 64 | COMPUTER RESOURCE TECH | 131 | 150 | LAHEY COMPUTER SYSTEMS | 137 | 228 | QUATECH | 316 |
| 65 | COMPUTERLANE | 201 | 151 | LAN-MARK SYSTEMS | 330 | 229 | QUATECH | 316 |
| 66 | COMPUTRADE | 104 | 152 | LAWSON LABS | 318 | 230 | RADIO SHACK | CIV |
| 67 | CONTROL CORP. | 236 | 153 | LINK COMPUTER GRAPHICS | 324 | * | RAIMA | 47 |
| 68 | CONTECH COMPUTER CORP. | 324 | 154 | LOGICAL DEVICES | 318 | 231 | RAINBOW TECH. | 147 |
| 69 | CONTROL VISION | 324 | 155 | LOGICAL DEVICES | 318 | 232 | RAINBOW TECH. | 147 |
| 71 | COVOX, INC. | 320 | 156 | LOGICAL DEVICES | 318 | 233 | RAINBOW TECH. | 224 |
| 72 | CW DATA LABS | 318 | 157 | LOGICAL DEVICES | 318 | 234 | RAINBOW TECH. | 224 |
| 73 | DATA TRANSLATION | 52 | 158 | LOGITECH | 81 | 235 | REAL TIME DEVICES | 324 |
| 74 | DATAMAN | 202 | * | MACMILLAN BOOK CLUBS | 28,29 | 236 | REFERENCE SOFTWARE | 223 |
| 315 | DATAPRO | 334 | 159 | MANNESMANN TALLEY | 53 | 237 | ROSE ELECTRONICS | 173 |
| * | DAYTRON ELECTRONICS | 324 | 160 | MANNESMANN TALLEY | 53 | 238 | SABINA INTERNATIONAL | 318 |
| 78 | DELL COMPUTER | CII, 1 | 163 | MAP INFO | 105 | 239 | SAFWARE INC. | 326 |
| * | DELL COMPUTER | 44A-B | 164 | MARYMAC INDUSTRIES | 316 | 240 | SAIC | 277 |
| 311 | DELTA COMPUTING TECH | 332 | 165 | MATHSOFT | 67 | 241 | SANMA | 31 |
| 79 | DEPARTMENTAL TECH. | 145 | 166 | MATHSOFT | 67 | 242 | SANTA CRUZ OPERATION | 224B |
| 243 | SCHWAB COMPUTER CENTER | 332 | 41 | SCIOTO COMPUTERS | 330 | 245 | SHAMROCK | 150 |
| 246 | SHECOM | 43 | 247 | SHECOM | 43 | 248 | SHECOM | 43 |
| 248 | SN'W ELECTRONICS | 38 | * | SOFTWARE DEVELOP. SYS. | 99 | 249 | SO. MOUNTAIN SOFTWARE | 265 |
| 250 | SPECTRUM | 91 | 251 | SPSS | 216 | 252 | STATSOFT | 127 |
| 251 | SPSS | 216 | 253 | STSC | 61 | 254 | SUPERSOFT | 273 |
| 252 | STATSOFT | 127 | 255 | SURAH INC | 325 | 256 | SYSGEN | 17 |
| 253 | STSC | 61 | 257 | TALKING TECHNOLOGY | 325 | 258 | TATUNG | 142 |
| 254 | SUPERSOFT | 273 | 259 | TECHNOLOGY RES. CTR. | 251 | 260 | TECHNOLOGY RES. CTR. | 251 |
| 255 | SURAH INC | 325 | 261 | TELCOR SYSTEMS | 30 | 262 | TELEBIT | 235 |
| 256 | SYSGEN | 17 | 263 | TELEBYTE TECHNOLOGY INC | 219 | 264 | TELEMART | 136 |
| 257 | TALKING TECHNOLOGY | 325 | 265 | TELEMART | 136 | 266 | THE GREAT SOFTWARE CO. | 193 |
| 258 | TATUNG | 142 | 267 | TOSHIBA | 106,107 | 268 | TOSHIBA | 107,107 |
| 259 | TECHNOLOGY RES. CTR. | 251 | 269 | TOUCHBASE SYSTEMS | 18 | 270 | TRAVELING SOFTWARE | 139 |
| 260 | TECHNOLOGY RES. CTR. | 251 | 271 | TRILOBYTE INC | 323 | 272 | TRUE DATA PRODUCTS | 26 |
| 261 | TELCOR SYSTEMS | 30 | 273 | TRUIVISION | 39 | 274 | TURBO POWER | 138 |
| 262 | TELEBIT | 235 | 274 | TURBO POWER | 138 | 275 | UNITEX | 336 |
| 263 | TELEBYTE TECHNOLOGY INC | 219 | 276 | UNIVERSAL CROSS ASSEMB | 325 | 277 | VENTUR COM | 248 |
| 264 | TELEMART | 136 | 278 | VENTUR COM | 248 | 279 | VENTURA PERIPHERALS | 153 |
| 265 | TELEMART | 136 | 280 | VERBATIM CORPORATION | 205 | * | VERMONT CREATIVE | 10 |
| 266 | THE GREAT SOFTWARE CO. | 193 | 281 | VERSACAD DESIGN | 194 | 283 | VNS AMERICA | 120,121 |
| 267 | TOSHIBA | 106,107 | 284 | VNS AMERICA | 226 | 285 | WAREHOUSE DATA | 23 |
| 268 | TOSHIBA | 107,107 | 286 | WELLS AMERICAN (N. AMERICA) | 19 | 287 | WELLS AMERICAN (INT'L) | 19 |
| 269 | TOUCHBASE SYSTEMS | 18 | 288 | WESTERN TELEMATIC | 174 | 289 | WESTERN TELEMATIC | 174 |
| 270 | TRAVELING SOFTWARE | 139 | 290 | WIESEMANN & THEIS | 250 | 291 | WINTEK | 5 |
| 271 | TRILOBYTE INC | 323 | 292 | WINTEK CORP. | 325 | 293 | XELTEK | 316 |
| 272 | TRUE DATA PRODUCTS | 26 | 294 | XENDER | 323 | 295 | XENDER | 325 |
| 273 | TRUIVISION | 39 | 296 | XENTEK | 325 | 297 | ZEOS INTERNATIONAL | 168,169 |
| 274 | TURBO POWER | 138 | 298 | ZERICON | 58 | 299 | ZORTECH | 167 |
| 275 | UNITEX | 336 | 300 | Z-WORLD | 326 | 301 | Z-WORLD | 326 |
| 276 | UNIVERSAL CROSS ASSEMB | 325 | | | | | | |
| 277 | VENTUR COM | 248 | | | | | | |
| 278 | VENTUR COM | 248 | | | | | | |
| 279 | VENTURA PERIPHERALS | 153 | | | | | | |
| 280 | VERBATIM CORPORATION | 205 | | | | | | |
| * | VERMONT CREATIVE | 10 | | | | | | |
| 281 | VERSACAD DESIGN | 194 | | | | | | |
| 283 | VNS AMERICA | 120,121 | | | | | | |
| 284 | VNS AMERICA | 226 | | | | | | |
| 285 | WAREHOUSE DATA | 23 | | | | | | |
| 286 | WELLS AMERICAN (N. AMERICA) | 19 | | | | | | |
| 287 | WELLS AMERICAN (INT'L) | 19 | | | | | | |
| 288 | WESTERN TELEMATIC | 174 | | | | | | |
| 289 | WESTERN TELEMATIC | 174 | | | | | | |
| 290 | WIESEMANN & THEIS | 250 | | | | | | |
| 291 | WINTEK | 5 | | | | | | |
| 292 | WINTEK CORP. | 325 | | | | | | |
| 293 | XELTEK | 316 | | | | | | |
| 294 | XENDER | 323 | | | | | | |
| 295 | XENDER | 325 | | | | | | |
| 296 | XENTEK | 325 | | | | | | |
| 297 | ZEOS INTERNATIONAL | 168,169 | | | | | | |

READER SERVICE

To get further information on the products advertised in BYTE, fill out the reader service card by circling the numbers on the card that correspond to the inquiry number listed with the advertiser. This index is provided as an additional service by the publisher, who assumes no liability for errors or omissions.

* Correspond directly with company.

Index to Advertisers by Product Category

| Inquiry No. | Page No. | Inquiry No. | Page No. | Inquiry No. | Page No. | Inquiry No. | Page No. |
|-----------------|--|-----------------------------------|-----------------------------------|---------------------------------|---------------------------------|---------------------------------|----------------------------------|
| HARDWARE | | | | | | | |
| 800 | ADD INS | 37 | B & C MICRO 325 | 261 | TELCOR SYSTEMS 30 | 214 | PROTECH MARKETING 54 |
| 12 | ADVANCED MICRO RES. 259 | 51 | BYTEK COMPUTER CORP 320 | 262 | TELEBIT 235 | 215 | PROTECH MARKETING 54 |
| 16 | ALPHA PRODUCTS COMPANY 327 | 122 | G-TEK 96 | 269 | TOUCHBASE SYSTEMS 18 | 231 | RAINBOW TECH. 147 |
| 403 | AMDS 96IS-10 | 123 | G-TEK 96 | 807 | MONITORS | 232 | RAINBOW TECH. 147 |
| 27 | ATI TECHNOLOGIES 159 | 146 | KORE, INC 324 | 404 | BERING INFORMATION CO. 96IS-28 | 233 | RAINBOW TECH. 224 |
| 36 | B & C MICRO 325 | 153 | LINK COMPUTER GRAPHICS . 324 | 425 | INTRA ELECTRONICS CO. 96IS-32 | 234 | RAINBOW TECH. 224 |
| 37 | B & C MICRO 325 | 154 | LOGICAL DEVICES 318 | * NEC HOME ELECT. 56,57 | | | |
| 405 | BEST COMMUNICATION . 96IS-30 | 155 | LOGICAL DEVICES 318 | 437 | PHILIPS LCD MONITORS . 96IS-15 | | |
| 407 | BLUE CHIP TECHNOLOGY 96IS-42 | 188 | NEEDHAM'S ELECTRONICS . 316 | 258 | TATUNG 142 | | |
| 56 | CAPITAL EQUIPMENT 154 | 293 | XELTEK 316 | 444 | TVM 96IS-44 | | |
| 60 | COMPUTER A GE LTD 323 | 294 | XENDER 323 | | | | |
| 67 | CONTROL CORP. 236 | 295 | XENDER 325 | 808 | NETWORK HARDWARE | | |
| 69 | CONTROL VISION 324 | 803 | INSTRUMENTATION | 402 | ADDER TECHNOLOGY . . 96IS-54 | 813 | SYSTEMS |
| 71 | COVOX, INC 320 | 88 | DSP 24 | 39 | BAY TECH 103 | 401 | ABC COMPUTER 96IS-35 |
| 410 | CUBIX 96IS-31 | 93 | ELEXOR INC 320 | 40 | BAY TECH 103 | 449 | ACER 96IS-46,47 |
| 311 | DELTA COMPUTING TECH . . 332 | 804 | KEYBOARDS/MICE | 410 | CUBIX 96IS-31 | 17 | ADVANCED LOGIC RES. . . . 76,77 |
| 91 | EDC 58 | * FORTE COMMUNICATIONS . 84 | | 411 | DATEX SYSTEMS 96IS-25 | 18 | ADVANCED LOGIC RES. . . . 76,77 |
| 101 | EOTRON CORP. 34 | 415 | GTCO 96IS-21 | 80 | DIGIBOARD 240 | * AMPRO 130 | |
| 102 | EOTRON CORP. 34 | 158 | LOGITECH 81 | 81 | DIGIBOARD 241 | 25 | AST RESEARCH 197 |
| 413 | GAMMA PRODUCTIONS . 96IS-18 | 500 | MEXTEL 96MW-2 | 419 | IES 96IS-40 | 26 | AST RESEARCH 197 |
| 305 | GENOA SYSTEMS CORP. . . 79 | 538 | MEXTEL 96PC-2 | 151 | LAN-MARK SYSTEMS . . . 330 | 42 | BEST COMPUTER 134 |
| 127 | HIGH RES TECHNOLOGY . . 330 | 445 | UNITECH 96IS-26 | 189 | NETWORK TECH. INC . . . 323 | 43 | BEST COMPUTER 134 |
| 421 | INES 96IS-36 | 805 | MASS STORAGE | 195 | OST 42 | 45 | BINARY TECHNOLOGY 320 |
| 422 | INTERQUADRAM 96IS-5 | 15 | AK SYSTEMS 332 | 191 | PERSONAL SPACE COMM . . 318 | 490 | BUSINESS MICRO SYS. . . . 96MW-4 |
| 423 | INTERQUADRAM 96IS-7 | 38 | BASF 208E | 237 | ROSE ELECTRONICS 173 | 491 | BUSINESS MICRO SYS. . . . 96MW-4 |
| 424 | INTERQUADRAM 96IS-9 | 68 | CONTECH COMPUTER CORP 324 | 288 | WESTERN TELEMATIC . . . 174 | * COMPAQ 82,83 | |
| 137 | IO TECH 249 | 143 | KADAK 60 | 289 | WESTERN TELEMATIC . . . 174 | 66 | COMPUTRADE 104 |
| 138 | IO TECH 318 | * MAXELL CORP. OF AMERICA . 73 | | 290 | WIESEMANN & THEIS . . . 250 | 478 | COMTEQ COMP. CORP. . . . 96SO-2 |
| 429 | KAP 96IS-23 | 302 | MEGA DRIVE 85 | 809 | POWER SUPPLIES | 479 | COMTEQ COMP. CORP. . . . 96SO-2 |
| 152 | LAWSON LABS 318 | 303 | MEGA DRIVE 85 | 95 | EMERSON 94 | 78 | DELL COMPUTER CIL,1 |
| 170 | MAXON 95 | 179 | MICROTECH 330 | 200 | PARA SYSTEMS 87 | * DELL COMPUTER 44A-B | |
| 171 | MAXON 95 | 196 | OVERLAND DATA 102 | 810 | PRINTERS/PLOTTERS | 412 | ELONEX 96IS-58 |
| 433 | MICRON TECH 96IS-39 | 220 | QUALSTAR CORP 326 | 32 | ADVANCED MATRIX TECH . . 209 | 107 | FORTRON 46 |
| 181 | MIRO DATENSYTTME 166 | 280 | VERBATIM CORPORATION . . 205 | 55 | CALCOMP 170 | 114 | GATEWAY 2000 8,9 |
| 195 | OST 42 | * MISCELLANEOUS | | 516 | DATAWARE PRODUCTS . . 96NE-8 | 416 | HAUPPAUGE 96IS-2 |
| 204 | PERISCOPE CO. 243 | 35 | B & B ELECTRONICS 323 | 110 | FUJITSU 14,15 | 523 | HERTZ COMPUTERS 96NE-2 |
| 205 | PERISCOPE CO. 243 | 100 | ENGINEERS COLLABORATIVE 320 | 111 | FUJITSU 14,15 | 417 | HWA HSIN ELECTRONIC CO. 96IS-20 |
| 191 | PERSONAL SPACE 318 | 115 | GEN. PARAMETRICS CORP . . 165 | 118 | GENICOM 88,89 | 498 | ISD 96MW-3 |
| 448 | PHILIPS INDUSTRIAL AUTOMATION SYSTEMS . 96IS-57 | 125 | HARRIS/3M 182,183 | 126 | HEWLETT-PACKARD PERIPH. 92,93 | 499 | ISD 96MW-3 |
| 226 | QUATECH 316 | 420 | IN WIN DEVELOPMENT . . 96IS-36 | 130 | HOUSTON INSTRUMENT . . . 191 | 525 | JASMINE COMPUTER SYS. 96NE-11 |
| 227 | QUATECH 316 | * INECTRA, INC. 318 | | 133 | IMPACT COMPUTER SYSTEMS 102 | 174 | MEGATEL 86 |
| 228 | QUATECH 316 | 134 | INTEGRAND 40 | 159 | MANNESMANN TALLEY . . . 53 | 309 | MICROCOM 260 |
| 229 | QUATECH 316 | 428 | KADOR 96IS-42 | 160 | MANNESMANN TALLEY . . . 53 | * NEC HOME ELECT. 36,37 | |
| 235 | REAL TIME DEVICES 324 | 501 | N-VIEW 96MW-11 | 248 | SN'W ELECTRONICS 38 | 508 | OWL COMPUTERS 96M/AT-2 |
| 257 | TALKING TECHNOLOGY . . . 325 | 263 | TELEBYTE TECHNOLOGY INC 219 | 279 | VENTURA PERIPHERALS . . 153 | 436 | PC CALC 96IS-28 |
| 273 | TRUEVISION 39 | 806 | MODEMS/MULTIPLEXORS | 298 | ZERICON 58 | 518 | PC LINK 96NE-6 |
| 801 | DRIVES | 405 | BEST COMMUNICATION . 96IS-30 | 811 | SCANNERS/DIGITIZERS | 218 | PI COMPUTER CORP. 213 |
| 302 | MEGA DRIVE 85 | * CLEO SOFTWARE 96IS-29 | | 96 | FLAGSTAFF 122 | 219 | PI COMPUTER CORP. 213 |
| 303 | MEGA DRIVE 85 | 58 | COMPUCOM 314 | 97 | FLAGSTAFF 122 | 216 | PROTEUS TECHNOLOGY CORP 27 |
| 256 | SYSGEN 17 | 482 | COWELL CORPORATION . 96SO-4 | 98 | FLAGSTAFF 122 | 230 | RADIO SHACK CIV |
| 802 | HARDWARE PROGRAMMERS | 483 | COWELL CORPORATION . 96SO-4 | 99 | FLAGSTAFF 122 | 41 | SCIOTO COMPUTERS 330 |
| 30 | AVOCET & QUELO 324 | 104 | E-TECH RESEARCH 332 | 272 | TRUE DATA PRODUCTS . . . 26 | 40 | SIEMENS 96IS-13 |
| 34 | B P MICROSYSTEMS 330 | 176 | MICRO TELESIS 44 | 812 | SOFTWARE SECURITY | 248 | SN'W ELECTRONICS 38 |
| 36 | B & C MICRO 325 | 192 | OKIDATA 55 | 408 | CONTROL TELEMETRY . . 96IS-34 | 442 | SUN MICROSYSTEMS 96IS-53 |

READER SERVICE

| Inquiry No. | Page No. | Inquiry No. | Page No. | Inquiry No. | Page No. | Inquiry No. | Page No. |
|---|----------|---------------------------------------|----------|---|----------|--------------------------------------|----------|
| SOFTWARE | | 241 SAMNA | 31 | 183 MIX SOFTWARE | 295 | 832 MAIL ORDER/RETAIL | |
| 814 APPLE2/MAC APPLICATIONS Business/Office | | 821 IBM/MSDOS - CAD | | 503 O.S. ASSOCIATES | 96MW-10 | 529 4 GUYS | 96PC-6 |
| 132 IMAGINE THAT! | 118 | 20 AMERICAN SMALL BUS. COMP. 132 | | 504 O.S. ASSOCIATES | 96MW-10 | 476 4 GUYS | 96SO-7 |
| 815 APPLE2/MAC APPLICATIONS Scientific/Technical | | 52 CAD SOFTWARE | 60 | 203 PAUL MACE SOFTWARE | 164 | 13 ADVANTAGE SOFTWARE | 255 |
| 132 IMAGINE THAT! | 118 | 53 CAD WAREHOUSE | 192 | 204 PERISCOPE CO. | 243 | 19 ALTEX ELECTRONICS | 319 |
| 165 MATHSOFT | 67 | 64 COMPUTER RESOURCE TECH 131 | | 205 PERISCOPE CO. | 243 | 24 APPLIED PROG. ELECT | 328,329 |
| 166 MATHSOFT | 67 | 105 FORESIGHT RESOURCES | 181 | 207 PETER NORTON | 215 | 31 A.C.P. | 337 |
| 251 SPSS | 216 | 106 FORESIGHT RESOURCES | 181 | 208 PETER NORTON | 215 | 33 A.N. WHOLESALE & RETAIL | 330 |
| 816 IBM/MSDOS APPLICATIONS Business/Office | | 438 RHV | 96IS-43 | 209 POCKETSOFT | 35 | 477 BELTRON COMPUTER | 96SO-5 |
| 530 AKER CORP. | 96PC-5 | 266 THE GREAT SOUTHWESTERN CO. 193 | | 210 PRIME SOLUTIONS | 199 | * BUYER'S MART | 300-311 |
| 531 AKER CORP. | 96PC-5 | 281 VERSACAD DESIGN | 194 | 211 PRIME SOLUTIONS | 199 | 532 BYTE + FLOPPY COMPUTERS | 96PC-7 |
| 61 COMPUTER ASSOCIATES | 70,71 | 291 WINTEK CORP | 5 | 222 QUARTERDECK | 148,149 | * CALIFORNIA DIGITAL | 317 |
| 72 CW DATA LABS | 318 | 292 WINTEK CORP | 325 | 223 QUARTERDECK | 148,149 | 306 CHIP FACTORY | 154 |
| 409 FORMOSA MICROSYS. INC. 96IS-45 | | 822 IBM/MSDOS - GRAPHICS | | 224 QUARTERDECK | 148,149 | 22 CLONE COMPUTER | 312,313 |
| 108 FOX SOFTWARE | 25 | * DAYTRON ELECTRONICS | 324 | 225 QUARTERDECK | 148,149 | * COMPACT DISK PRODUCTS | 277 |
| 109 FTGDATASYSTEMS | 320 | 519 ISLAND SYSTEMS | 96NE-9 | 441 SOFTWARE CONSTRUCTN 96IS-55 | | 57 COMPUCLASSICS | 244 |
| 116 GENERIC SOFTWARE | 187 | 535 ISLAND SYSTEMS | 96PC-7 | 249 SOUTH MOUNTAIN SOFTWARE 265 | | 59 COMPUSAVE | 315 |
| 117 GENERIC SOFTWARE | 187 | 823 IBM/MSDOS - LANGUAGES | | 254 SUPERSOFT | 273 | 62 COMPUTER MAIL ORDER | 48,49 |
| 435 NOVELL DEVELOPMENT 96IS-37 | | 10 2500 | 96IS | 274 TURBO POWER | 138 | 65 COMPUTERLANE | 201 |
| * ORACLE | 75 | AD SOFTWARE | 242 | * VERMONT CREATIVE | 10 | 492 CONTINENTAL TRADING INC | 96MW-6,7 |
| * RAIMA | 47 | 29 AVOCET SYSTEMS | 59 | 299 ZORTECH | 167 | 493 CONTINENTAL TRADING INC | 96MW-6,7 |
| 236 REFERENCE SOFTWARE | 223 | * CALEND | 96IS-63 | 825 IBM/MSDOS COMMUNICATIONS | | 494 CORP. COMP. OF IOWA | 96MW-1 |
| 270 TRAVELING SOFTWARE | 139 | 94 ELLIS COMPUTING | 214 | 308 CENTURY DATA | 274 | 495 CORP. COMP. OF IOWA | 96MW-1 |
| 817 IBM/MSDOS APPLICATIONS Scientific/Technical | | 124 HAMMERLY COMPUTER SERV. 33 | | 507 COMMUNICATION RESEARCH GROUP | 96M/AT-1 | 480 CORP. COMP. OF IOWA | 96SO-3 |
| 44 BINARY ENGINEERING | 200 | 141 JENSEN & PARTNERS INC | 125 | 515 COMMUNICATION RESEARCH GROUP | 96NE-10 | 481 CORP. COMP. OF IOWA | 96SO-3 |
| 54 CADRE TECHNOLOGIES | 264 | 142 JYACC, INC. | 233 | 87 DIVERSIFIED COMPUTER SYS 324 | | 85 DISKCOTECH | 326 |
| 90 ECOSOFT | 20 | 148 LAHEY COMPUTER SYSTEMS 133 | | 144 KEA SYSTEMS | 239 | 86 DISKETTE CONNECTION | 323 |
| 124 HAMMERLY COMPUTER SERV. 33 | | 149 LAHEY COMPUTER SYSTEMS 135 | | 186 NATURAL MICROSYSTEMS | 146 | 89 DYNAMIC ELECTRONICS | 324 |
| 129 HORSTMANN SOFTWARE | 289 | 150 LAHEY COMPUTER SYSTEMS 137 | | 312 NORTON LAMBERT | 21 | 517 ELECTRIFIED DISCONTRS | 96NE-3 |
| 313 NATIONAL INSTRUMENTS | CIII | 156 LOGICAL DEVICES | 318 | 199 PALLADIAN TECHNOLOGIES | 326 | 103 EXECUTIVE PHOTO & SUPPLY 208B | |
| 314 NATIONAL INSTRUMENTS | CIII | 157 LOGICAL DEVICES | 318 | 826 OTHER APPLICATIONS Business/Office | | 414 GREY MATTER | 96IS-61 |
| 202 PATTON & PATTON | 128 | * MICROSOFT | 13 | 259 TECHNOLOGY RESOURCE CTR 251 | | 497 HARD DRIVES INT'L | 96MW-8 |
| 206 PERSONAL TEX | 220 | 307 POLYTRON | 267 | 260 TECHNOLOGY RESOURCE CTR 251 | | 485 HARD DRIVES INT'L | 96SO-1 |
| 250 SPECTRUM | 91 | 240 SAIC | 277 | 827 OTHER APPLICATIONS Miscellaneous | | 484 HARD DRIVES INT'L | 96SO-1 |
| 252 STATSOFT | 127 | 299 ZORTECH | 167 | 163 MAP INFO | 105 | 131 IC EXPRESS | 323 |
| 253 STSC | 61 | 824 IBM/MSDOS - UTILITIES | | 271 TRILOBYTE INC | 323 | 133 IMPACT COMPUTER SYSTEMS 102 | |
| 818 IBM/MSDOS APPLICATIONS Miscellaneous | | 11 ABRAXAS SOFTWARE | 258 | 828 OTHER - LANGUAGES | | 426 I.C.C. | 96IS-33 |
| 524 SOFTWARE BOTTLING CO 96NE-4,5 | | 28 ATRON | 64 | 201 PARCPLACE SYSTEMS | 119 | 139 JADE | 335 |
| 819 IBM/MSDOS APPLICATIONS Spreadsheet | | 47 BLAISE COMPUTING | 45 | 259 TECHNOLOGY RESOURCE CTR 251 | | 140 JAMECO | 320A-H |
| 217 PUNCTUM | 316 | 48 BOLT SYSTEMS | 54 | 260 TECHNOLOGY RESOURCE CTR 251 | | 140 JAMECO | 321,322 |
| 820 IBM/MSDOS APPLICATIONS Word Processing | | 49 BORLAND | 69 | 300 Z-WORLD | 326 | 536 JB TECHNOLOGIES | 96PC-3 |
| 14 AGRANAT | 126 | 50 BORLAND | 69 | 301 Z-WORLD | 326 | 6 J.D.R. | 338-341 |
| | | * DAYTRON ELECTRONICS | 324 | 829 OTHER - CROSS DEVELOPMENT | | 7 J.D.R. | 338-341 |
| | | 79 DEPARTMENTAL TECHNOLOGIES | 145 | * SOFTWARE DEVELOP. SYS | 99 | 147 LA COMPUTER | 331 |
| | | 112 FUTURE COMPUTER SYS. | 101 | 276 UNIVERSAL CROSS ASSEMBLERS | 325 | 520 MANCHESTER EQUIPMENT 96NE-1 | |
| | | 113 FUTURE COMPUTER SYS. | 101 | | | 164 MARYMAC INDUSTRIES | 316 |
| | | 120 GOLDEN BOW | 124 | | | 431 MAYFAIR MICROS | 96IS-22 |
| | | 121 GOLDEN BOW | 124 | | | 172 MEAD COMPUTER | 333 |
| | | 124 HAMMERLY COMPUTER SERV. 33 | | | | 173 MEGASOFT | 330 |
| | | 128 HI-TECH EQUIP. CORP | 320 | | | 175 MERRITT COMPUTER PROD. | 278 |
| | | 142 JYACC, INC. | 233 | | | 539 MICRO UNIVERSE | 96PC-4 |
| | | 145 KNOWLEDGE GARDEN | 208G | | | 432 MICROMINT/J.B. DESIGNS 96IS-24 | |
| | | 430 MASHOV SOFTWARE EXP. 96IS-17 | | | | 177 MICROPROCESSORS UNLTD | 330 |
| | | 167 MATRIX | 116 | | | 180 MICROWAY | 207 |
| | | 182 MIX SOFTWARE | 141 | | | * MICROWAY | 41 |

READER SERVICE

| Inquiry No. | Page No. | Inquiry No. | Page No. | Inquiry No. | Page No. | Inquiry No. | Page No. | | | | | | |
|----------------------------------|----------|---------------------------------------|----------|-------------------------------|----------|------------------------------|----------|-----------------------------------|---------|--------------------------------|---------|----------------------------------|------|
| 184 MKS | 252 | 833 EDUCATIONAL/ INSTRUCTIONAL | | 834 DESKTOP PUBLISHING | | 836 OPERATING SYSTEMS | | | | | | | |
| * MONTGOMERY GRANT | 156 | | | | | | | | | | | | |
| 190 NITRO MICRO | 175 | | | | | | | 23 ANNABOOKS | 314 | * ADOBE | 115 | 8 2001 SALES | 198 |
| 194 ON-LINE STORE | 210 | | | | | | | * BYTE BACK ISSUES | 314 | 534 DIGI-FONTS | 96PC-1 | 9 2001 SALES | 198 |
| 197 PACIFIC COMPUTER | 315 | | | | | | | * BYTE BACK ISSUES | 96IS-52 | 526 DIGI-FONTS | 96NE-7 | * ALCYON | 155 |
| 198 PACIFIC COMPUTER | 315 | | | | | | | 310 BYTE BITS | 316,332 | | | 82 DIGITAL RESEARCH | 50 |
| 522 PATRIOT COMPUTERS | 96NE-9 | | | | | | | * BYTE BOOK CLUB | 160,161 | | | 83 DIGITAL RESEARCH | 50 |
| 212 PROGRAMMERS PARADISE | 62,63 | | | | | | | * BYTE INTERNATIONAL | 96IS-64 | | | * IBM | 208A |
| 213 PROGRAMMERS SHOP | 126 | | | | | | | * BYTE SUB. MESSAGE | 219 | | | 135 INTERACTIVE SYSTEMS | 7 |
| 238 SABINA INTERNATIONAL | 318 | | | | | | | * BYTE SUB. SERVICE | 256 | 835 RECRUITMENT | | 136 INTERACTIVE SYSTEMS | 7 |
| 243 SCHWAB COMPUTER CENTER | 332 | | | | | | | * BYTEWEEK/NEWSLETTER | 214 | 537 KAISER PERMANENTE | 96PC-6 | 304 NEW GENERATION SYSTEMS | 318 |
| 439 SELTEC COMPUTER PROD. | 96IS-41 | | | | | | | * BYTEWEEK/NEWSLETTER | 282 | * SCANDEC TRIBUTOR, INC. | 96IS-19 | 221 QUANTUM SOFTWARE | 229 |
| 245 SHAMROCK | 150 | | | | | | | 63 COMPUTER PROF. BOOK SOC. | 129 | * SOFTLINE CORP | 96IS-54 | 242 SANTA CRUZ OPERATION | 224B |
| 246 SHECOM | 43 | | | | | | | 315 DATAPRO | 334 | | | 277 VENTUR COM | 248 |
| 247 SHECOM | 43 | | | | | | | 73 DATA TRANSLATION | 52 | * MISCELLANEOUS | | 278 VENTUR COM | 248 |
| 248 SN'W ELECTRONICS | 38 | | | | | | | * DATA TRANSLATION | 112A-F | * ANTHRO | 26 | | |
| * SOFTLINE CORP | 96IS-27 | | | | | | | 74 DATAMAN | 202 | 418 IXI | 96IS-38 | | |
| 255 SURAH INC | 325 | | | | | | | * MACMILLAN BOOK CLUBS | 28,29 | 193 ON TARGET ASSOCIATES | 326 | | |
| 264 TELEMART | 136 | | | | | | | * MCGRAW-HILL NRI | 96C1-2 | 239 SAFEWARE INC. | 326 | | |
| 265 TELEMART | 136 | | | | | | | 178 MICROSOFT PRESS | 162 | | | | |
| 275 UNITEX | 336 | | | | | | | * P C EXPO | 290 | | | | |
| 447 USA SOFTWARE | 96IS-11 | | | | | | | | | | | | |
| 285 WAREHOUSE DATA | 23 | | | | | | | | | | | | |
| 296 XENTEK | 325 | | | | | | | | | | | | |
| 502 YES MULTINATIONAL INC. | 96MW-5,8 | | | | | | | | | | | | |

TIPS

BYTE READERS!*

Use *BYTE's* Telephone Inquiry Processing System
Using *TIPS* can bring product information as much as 10 days earlier.

SEND FOR YOUR READER I.D. CARD

- 1) If you are a new Reader or have lost your I.D. Card, circle #1 on the Reader Service Card. We will immediately send your personal TIPS Reader I.D. Card.

GET PREPARED

- 2) Write your Reader Number, as printed on your Reader I.D. Card, in boxes in Step 5 below. (Do not add 0's to fill in blank boxes)
- 3) Write numbers for information desired in boxes in Step 7b below. (Do not add 0's to fill in blank boxes.)

CALL TIPS

- 4) Now, on a Touch-Tone telephone dial: (413) 637-3170 and wait for voice commands.

ENTER YOUR I.D. AND ISSUE NUMBERS

- 5) When TIPS says: "Enter Reader Number"
(Enter by pushing the numbers and # - symbols enclosed in the boxes on telephone pad ignoring blank boxes)
Enter # #
- 6) When TIPS says "Enter magazine code & issue code"
Enter # # #

ENTER YOUR INQUIRIES

- 7a) When TIPS says "Enter (next) Inquiry Number"
Enter one inquiry selection from below (ignore blank boxes)
- 7b) Repeat 7a as needed (maximum 17 inquiry numbers)

| | | | |
|--|--|---|---|
| 1. <input type="checkbox"/> <input type="checkbox"/> <input type="checkbox"/> <input type="checkbox"/> # # | 6. <input type="checkbox"/> <input type="checkbox"/> <input type="checkbox"/> <input type="checkbox"/> # # | 10. <input type="checkbox"/> <input type="checkbox"/> <input type="checkbox"/> <input type="checkbox"/> # # | 14. <input type="checkbox"/> <input type="checkbox"/> <input type="checkbox"/> <input type="checkbox"/> # # |
| 2. <input type="checkbox"/> <input type="checkbox"/> <input type="checkbox"/> <input type="checkbox"/> # # | 7. <input type="checkbox"/> <input type="checkbox"/> <input type="checkbox"/> <input type="checkbox"/> # # | 11. <input type="checkbox"/> <input type="checkbox"/> <input type="checkbox"/> <input type="checkbox"/> # # | 15. <input type="checkbox"/> <input type="checkbox"/> <input type="checkbox"/> <input type="checkbox"/> # # |
| 3. <input type="checkbox"/> <input type="checkbox"/> <input type="checkbox"/> <input type="checkbox"/> # # | 8. <input type="checkbox"/> <input type="checkbox"/> <input type="checkbox"/> <input type="checkbox"/> # # | 12. <input type="checkbox"/> <input type="checkbox"/> <input type="checkbox"/> <input type="checkbox"/> # # | 16. <input type="checkbox"/> <input type="checkbox"/> <input type="checkbox"/> <input type="checkbox"/> # # |
| 4. <input type="checkbox"/> <input type="checkbox"/> <input type="checkbox"/> <input type="checkbox"/> # # | 9. <input type="checkbox"/> <input type="checkbox"/> <input type="checkbox"/> <input type="checkbox"/> # # | 13. <input type="checkbox"/> <input type="checkbox"/> <input type="checkbox"/> <input type="checkbox"/> # # | 17. <input type="checkbox"/> <input type="checkbox"/> <input type="checkbox"/> <input type="checkbox"/> # # |
| 5. <input type="checkbox"/> <input type="checkbox"/> <input type="checkbox"/> <input type="checkbox"/> # # | | | |

END SESSION

- 8) End session by entering # #
- 9) Hang up after hearing final message
If you need assistance, call (603) 924-9281.

**Available 24 Hours,
7 Days a Week**

If you are not a subscriber fill out the subscription card found in this issue or, call BYTE Circulation 800-525-5003.

*Domestic and Canadian Only!

FREE INFORMATION

Want More Information About the Products and Advertisers Featured in this Issue?

1

Circle numbers on reply card which correspond to numbers assigned to items of interest to you.

2

Check all the appropriate answers to questions "A" through "C".

3

Print your name and address and mail.

Fill out this coupon carefully. PLEASE PRINT.

Name _____

Title _____ (_____) Phone _____

Company _____

Address _____

City _____ State _____ Zip _____

A. What is your level of management responsibility?

- 1 Senior-level Management
- 2 Other Management
- 3 Non-Management

B. What is your primary job function/principal area of responsibility? (Check one.)

- 1 Administration
- 2 Accounting/Finance
- 3 MIS/DP/Information Center
- 4 Product Design and Development
- 5 Research and Development
- 6 Manufacturing
- 7 Sales/Marketing
- 8 Purchasing
- 9 Personnel
- 10 Education/Training
- 11 Other: _____

C. Please indicate your organization's primary business activity: (Check one.)

- 1 Manufacturer (Hardware, Software)

- 2 Computer Retail Stores
- 3 Consultants
- 4 Service Bureau/Planning
- 5 Distributor/Wholesaler
- 6 Systems House/Integrator/VAR
- 7 Other: _____

Non-Computer-Related Businesses:

- 8 Manufacturing
- 9 Finance, Insurance, Real Estate
- 10 Retail/Wholesale
- 11 Education
- 12 Government
- 13 Military
- 14 Professions (Law, Medicine, Engineering, Architecture)
- 15 Consulting
- 16 Other Business Services
- 17 Transportation, Communications, Utilities
- 18 Other: _____

MAY
IRSD002

| | | | | | | | | | | | | | | | | | | | | | | | | | | | | | | |
|------|------|------|------|------|------|------|------|------|------|------|------|------|------|------|------|------|------|------|------|------|------|------|------|------|------|------|------|------|------|--|
| 1 | 2 | 3 | 4 | 5 | 6 | 7 | 8 | 9 | 10 | 11 | 12 | 13 | 14 | 15 | 16 | 17 | 18 | 19 | 20 | 21 | 22 | 23 | 24 | 25 | 26 | 27 | 28 | 29 | 30 | |
| 31 | 32 | 33 | 34 | 35 | 36 | 37 | 38 | 39 | 40 | 41 | 42 | 43 | 44 | 45 | 46 | 47 | 48 | 49 | 50 | 51 | 52 | 53 | 54 | 55 | 56 | 57 | 58 | 59 | 60 | |
| 61 | 62 | 63 | 64 | 65 | 66 | 67 | 68 | 69 | 70 | 71 | 72 | 73 | 74 | 75 | 76 | 77 | 78 | 79 | 80 | 81 | 82 | 83 | 84 | 85 | 86 | 87 | 88 | 89 | 90 | |
| 91 | 92 | 93 | 94 | 95 | 96 | 97 | 98 | 99 | 100 | 101 | 102 | 103 | 104 | 105 | 106 | 107 | 108 | 109 | 110 | 111 | 112 | 113 | 114 | 115 | 116 | 117 | 118 | 119 | 120 | |
| 121 | 122 | 123 | 124 | 125 | 126 | 127 | 128 | 129 | 130 | 131 | 132 | 133 | 134 | 135 | 136 | 137 | 138 | 139 | 140 | 141 | 142 | 143 | 144 | 145 | 146 | 147 | 148 | 149 | 150 | |
| 151 | 162 | 163 | 164 | 165 | 166 | 167 | 168 | 169 | 170 | 171 | 172 | 173 | 174 | 175 | 176 | 177 | 178 | 179 | 180 | 181 | 182 | 183 | 184 | 185 | 186 | 187 | 188 | 189 | 190 | |
| 191 | 192 | 193 | 194 | 195 | 196 | 197 | 198 | 199 | 200 | 201 | 202 | 203 | 204 | 205 | 206 | 207 | 208 | 209 | 210 | 211 | 212 | 213 | 214 | 215 | 216 | 217 | 218 | 219 | 220 | |
| 221 | 222 | 223 | 224 | 225 | 226 | 227 | 228 | 229 | 230 | 231 | 232 | 233 | 234 | 235 | 236 | 237 | 238 | 239 | 240 | 241 | 242 | 243 | 244 | 245 | 246 | 247 | 248 | 249 | 250 | |
| 251 | 252 | 253 | 254 | 255 | 256 | 257 | 258 | 259 | 260 | 261 | 262 | 263 | 264 | 265 | 266 | 267 | 268 | 269 | 270 | 271 | 272 | 273 | 274 | 275 | 276 | 277 | 278 | 279 | 280 | |
| 281 | 282 | 283 | 284 | 285 | 286 | 287 | 288 | 289 | 290 | 291 | 292 | 293 | 294 | 295 | 296 | 297 | 298 | 299 | 300 | 301 | 302 | 303 | 304 | 305 | 306 | 307 | 308 | 309 | 310 | |
| 311 | 312 | 313 | 314 | 315 | 316 | 317 | 318 | 319 | 320 | 321 | 322 | 323 | 324 | 325 | 326 | 327 | 328 | 329 | 330 | 331 | 332 | 333 | 334 | 335 | 336 | 337 | 338 | 339 | 340 | |
| 341 | 342 | 343 | 344 | 345 | 346 | 347 | 348 | 349 | 350 | 351 | 352 | 353 | 354 | 355 | 356 | 357 | 358 | 359 | 360 | 361 | 362 | 363 | 364 | 365 | 366 | 367 | 368 | 369 | 370 | |
| 371 | 372 | 373 | 374 | 375 | 376 | 377 | 378 | 379 | 380 | 381 | 382 | 383 | 384 | 385 | 386 | 387 | 388 | 389 | 390 | 391 | 392 | 393 | 394 | 395 | 396 | 397 | 398 | 399 | 400 | |
| 401 | 402 | 403 | 404 | 405 | 406 | 407 | 408 | 409 | 410 | 411 | 412 | 413 | 414 | 415 | 416 | 417 | 418 | 419 | 420 | 421 | 422 | 423 | 424 | 425 | 426 | 427 | 428 | 429 | 430 | |
| 431 | 432 | 433 | 434 | 435 | 436 | 437 | 438 | 439 | 440 | 441 | 442 | 443 | 444 | 445 | 446 | 447 | 448 | 449 | 450 | 451 | 452 | 453 | 454 | 455 | 456 | 457 | 458 | 459 | 460 | |
| 461 | 462 | 463 | 464 | 465 | 466 | 467 | 468 | 469 | 470 | 471 | 472 | 473 | 474 | 475 | 476 | 477 | 478 | 479 | 480 | 481 | 482 | 483 | 484 | 485 | 486 | 487 | 488 | 489 | 490 | |
| 491 | 492 | 493 | 494 | 495 | 496 | 497 | 498 | 499 | 500 | 501 | 502 | 503 | 504 | 505 | 506 | 507 | 508 | 509 | 510 | 511 | 512 | 513 | 514 | 515 | 516 | 517 | 518 | 519 | 520 | |
| 521 | 522 | 523 | 524 | 525 | 526 | 527 | 528 | 529 | 530 | 531 | 532 | 533 | 534 | 535 | 536 | 537 | 538 | 539 | 540 | 541 | 542 | 543 | 544 | 545 | 546 | 547 | 548 | 549 | 550 | |
| 551 | 552 | 553 | 554 | 555 | 556 | 557 | 558 | 559 | 560 | 561 | 562 | 563 | 564 | 565 | 566 | 567 | 568 | 569 | 570 | 571 | 572 | 573 | 574 | 575 | 576 | 577 | 578 | 579 | 580 | |
| 581 | 582 | 583 | 584 | 585 | 586 | 587 | 588 | 589 | 590 | 591 | 592 | 593 | 594 | 595 | 596 | 597 | 598 | 599 | 600 | 601 | 602 | 603 | 604 | 605 | 606 | 607 | 608 | 609 | 610 | |
| 611 | 612 | 613 | 614 | 615 | 616 | 617 | 618 | 619 | 620 | 621 | 622 | 623 | 624 | 625 | 626 | 627 | 628 | 629 | 630 | 631 | 632 | 633 | 634 | 635 | 636 | 637 | 638 | 639 | 640 | |
| 641 | 642 | 643 | 644 | 645 | 646 | 647 | 648 | 649 | 650 | 651 | 652 | 653 | 654 | 655 | 656 | 657 | 658 | 659 | 660 | 661 | 662 | 663 | 664 | 665 | 666 | 667 | 668 | 669 | 670 | |
| 671 | 672 | 673 | 674 | 675 | 676 | 677 | 678 | 679 | 680 | 681 | 682 | 683 | 684 | 685 | 686 | 687 | 688 | 689 | 690 | 691 | 692 | 693 | 694 | 695 | 696 | 697 | 698 | 699 | 700 | |
| 701 | 702 | 703 | 704 | 705 | 706 | 707 | 708 | 709 | 710 | 711 | 712 | 713 | 714 | 715 | 716 | 717 | 718 | 719 | 720 | 721 | 722 | 723 | 724 | 725 | 726 | 727 | 728 | 729 | 730 | |
| 731 | 732 | 733 | 734 | 735 | 736 | 737 | 738 | 739 | 740 | 741 | 742 | 743 | 744 | 745 | 746 | 747 | 748 | 749 | 750 | 751 | 752 | 753 | 754 | 755 | 756 | 757 | 758 | 759 | 760 | |
| 761 | 762 | 763 | 764 | 765 | 766 | 767 | 768 | 769 | 770 | 771 | 772 | 773 | 774 | 775 | 776 | 777 | 778 | 779 | 780 | 781 | 782 | 783 | 784 | 785 | 786 | 787 | 788 | 789 | 790 | |
| 791 | 792 | 793 | 794 | 795 | 796 | 797 | 798 | 799 | 800 | 801 | 802 | 803 | 804 | 805 | 806 | 807 | 808 | 809 | 810 | 811 | 812 | 813 | 814 | 815 | 816 | 817 | 818 | 819 | 820 | |
| 821 | 822 | 823 | 824 | 825 | 826 | 827 | 828 | 829 | 830 | 831 | 832 | 833 | 834 | 835 | 836 | 837 | 838 | 839 | 840 | 841 | 842 | 843 | 844 | 845 | 846 | 847 | 848 | 849 | 850 | |
| 851 | 852 | 853 | 854 | 855 | 856 | 857 | 858 | 859 | 860 | 861 | 862 | 863 | 864 | 865 | 866 | 867 | 868 | 869 | 870 | 871 | 872 | 873 | 874 | 875 | 876 | 877 | 878 | 879 | 880 | |
| 881 | 882 | 883 | 884 | 885 | 886 | 887 | 888 | 889 | 890 | 891 | 892 | 893 | 894 | 895 | 896 | 897 | 898 | 899 | 900 | 901 | 902 | 903 | 904 | 905 | 906 | 907 | 908 | 909 | 910 | |
| 911 | 912 | 913 | 914 | 915 | 916 | 917 | 918 | 919 | 920 | 921 | 922 | 923 | 924 | 925 | 926 | 927 | 928 | 929 | 930 | 931 | 932 | 933 | 934 | 935 | 936 | 937 | 938 | 939 | 940 | |
| 941 | 942 | 943 | 944 | 945 | 946 | 947 | 948 | 949 | 950 | 951 | 952 | 953 | 954 | 955 | 956 | 957 | 958 | 959 | 960 | 961 | 962 | 963 | 964 | 965 | 966 | 967 | 968 | 969 | 970 | |
| 971 | 972 | 973 | 974 | 975 | 976 | 977 | 978 | 979 | 980 | 981 | 982 | 983 | 984 | 985 | 986 | 987 | 988 | 989 | 990 | 991 | 992 | 993 | 994 | 995 | 996 | 997 | 998 | 999 | 1000 | |
| 1001 | 1002 | 1003 | 1004 | 1005 | 1006 | 1007 | 1008 | 1009 | 1010 | 1011 | 1012 | 1013 | 1014 | 1015 | 1016 | 1017 | 1018 | 1019 | 1020 | 1021 | 1022 | 1023 | 1024 | 1025 | 1026 | 1027 | 1028 | 1029 | 1030 | |
| 1031 | 1032 | 1033 | 1034 | 1035 | 1036 | 1037 | 1038 | 1039 | 1040 | 1041 | 1042 | 1043 | 1044 | 1045 | 1046 | 1047 | 1048 | 1049 | 1050 | 1051 | 1052 | 1053 | 1054 | 1055 | 1056 | 1057 | 1058 | 1059 | 1060 | |
| 1061 | 1062 | 1063 | 1064 | 1065 | 1066 | 1067 | 1068 | 1069 | 1070 | 1071 | 1072 | 1073 | 1074 | 1075 | 1076 | 1077 | 1078 | 1079 | 1080 | 1081 | 1082 | 1083 | 1084 | 1085 | 1086 | 1087 | 1088 | 1089 | 1090 | |
| 1091 | 1092 | 1093 | 1094 | 1095 | 1096 | 1097 | 1098 | 1099 | 1100 | 1101 | 1102 | 1103 | 1104 | 1105 | 1106 | 1107 | 1108 | 1109 | 1110 | 1111 | 1112 | 1113 | 1114 | 1115 | 1116 | 1117 | 1118 | 1119 | 1120 | |
| 1121 | 1122 | 1123 | 1124 | 1125 | 1126 | 1127 | 1128 | 1129 | 1130 | 1131 | 1132 | 1133 | 1134 | 1135 | 1136 | 1137 | 1138 | 1139 | 1140 | 1141 | 1142 | 1143 | 1144 | 1145 | 1146 | 1147 | 1148 | 1149 | 1150 | |
| 1151 | 1152 | 1153 | 1154 | 1155 | 1156 | 1157 | 1158 | 1159 | 1160 | 1161 | 1162 | 1163 | 1164 | 1165 | 1166 | 1167 | 1168 | 1169 | 1170 | 1171 | 1172 | 1173 | 1174 | 1175 | 1176 | 1177 | 1178 | 1179 | 1180 | |
| 1181 | 1182 | 1183 | 1184 | 1185 | 1186 | 1187 | 1188 | 1189 | 1190 | 1191 | 1192 | 1193 | 1194 | 1195 | 1196 | 1197 | 1198 | 1199 | 1200 | | | | | | | | | | | |

Please send me one year of BYTE Magazine for \$24.95 and bill me. Offer valid in U.S. and possessions only.



NO POSTAGE
NECESSARY
IF MAILED
IN THE
UNITED STATES

BUSINESS REPLY MAIL
FIRST CLASS MAIL PERMIT NO. 176 PITTSFIELD, MA

POSTAGE WILL BE PAID BY ADDRESSEE



READER SERVICE
PO Box 5110
Pittsfield, MA 01203-9926
USA



FREE INFORMATION

Want More Information About the Products and Advertisers Featured in this Issue?

- 1** Circle numbers on reply card which correspond to numbers assigned to items of interest to you.
- 2** Check all the appropriate answers to questions "A" through "C".
- 3** Print your name and address and mail.



NO POSTAGE
NECESSARY
IF MAILED
IN THE
UNITED STATES

BUSINESS REPLY MAIL
FIRST CLASS MAIL PERMIT NO. 176 PITTSFIELD, MA

POSTAGE WILL BE PAID BY ADDRESSEE

BYTE

READER SERVICE
PO Box 5110
Pittsfield, MA 01203-9926
USA

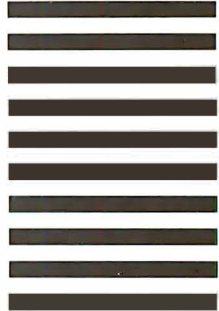

Fill out this coupon carefully. PLEASE PRINT.

Name _____
 Title _____ (_____) Phone _____
 Company _____
 Address _____
 City _____ State _____ Zip _____

- A. What is your level of management responsibility?**
 Senior-level Management
 Other Management
 Non-Management
- B. What is your primary job function/principal area of responsibility? (Check one.)**
 Administration
 Accounting/Finance
 MIS/DP/Information Center
 Product Design and Development
 Research and Development
 Manufacturing
 Sales/Marketing
 Purchasing
 Personnel
 Education/Training
 Other: _____
- C. Please indicate your organization's primary business activity: (Check one.)**
 Manufacturer (Hardware, Software)
- Computer Retail Stores
 Consultants
 Service Bureau/Planning
 Distributor/Wholesaler
 Systems House/Integrator/VAR
 Other: _____
- Non-Computer-Related Businesses:**
 Manufacturing
 Finance, Insurance, Real Estate
 Retail/Wholesale
 Education
 Government
 Military
 Professions (Law, Medicine, Engineering, Architecture)
 Consulting
 Other Business Services
 Transportation, Communications, Utilities
 Other: _____

| | | | | | | | | | | | | | | | | | | | | | | | | | | | | | |
|------|------|------|------|------|------|------|------|------|------|------|------|------|------|------|------|------|------|------|------|------|------|------|------|------|------|------|------|------|------|
| 1 | 2 | 3 | 4 | 5 | 6 | 7 | 8 | 9 | 10 | 11 | 12 | 13 | 14 | 15 | 16 | 17 | 18 | 19 | 20 | 21 | 22 | 23 | 24 | 25 | 26 | 27 | 28 | 29 | 30 |
| 31 | 32 | 33 | 34 | 35 | 36 | 37 | 38 | 39 | 40 | 41 | 42 | 43 | 44 | 45 | 46 | 47 | 48 | 49 | 50 | 51 | 52 | 53 | 54 | 55 | 56 | 57 | 58 | 59 | 60 |
| 61 | 62 | 63 | 64 | 65 | 66 | 67 | 68 | 69 | 70 | 71 | 72 | 73 | 74 | 75 | 76 | 77 | 78 | 79 | 80 | 81 | 82 | 83 | 84 | 85 | 86 | 87 | 88 | 89 | 90 |
| 91 | 92 | 93 | 94 | 95 | 96 | 97 | 98 | 99 | 100 | 101 | 102 | 103 | 104 | 105 | 106 | 107 | 108 | 109 | 110 | 111 | 112 | 113 | 114 | 115 | 116 | 117 | 118 | 119 | 120 |
| 121 | 122 | 123 | 124 | 125 | 126 | 127 | 128 | 129 | 130 | 131 | 132 | 133 | 134 | 135 | 136 | 137 | 138 | 139 | 140 | 141 | 142 | 143 | 144 | 145 | 146 | 147 | 148 | 149 | 150 |
| 151 | 152 | 153 | 154 | 155 | 156 | 157 | 158 | 159 | 160 | 161 | 162 | 163 | 164 | 165 | 166 | 167 | 168 | 169 | 170 | 171 | 172 | 173 | 174 | 175 | 176 | 177 | 178 | 179 | 180 |
| 181 | 182 | 183 | 184 | 185 | 186 | 187 | 188 | 189 | 190 | 191 | 192 | 193 | 194 | 195 | 196 | 197 | 198 | 199 | 200 | 201 | 202 | 203 | 204 | 205 | 206 | 207 | 208 | 209 | 210 |
| 211 | 212 | 213 | 214 | 215 | 216 | 217 | 218 | 219 | 220 | 221 | 222 | 223 | 224 | 225 | 226 | 227 | 228 | 229 | 230 | 231 | 232 | 233 | 234 | 235 | 236 | 237 | 238 | 239 | 240 |
| 241 | 242 | 243 | 244 | 245 | 246 | 247 | 248 | 249 | 250 | 251 | 252 | 253 | 254 | 255 | 256 | 257 | 258 | 259 | 260 | 261 | 262 | 263 | 264 | 265 | 266 | 267 | 268 | 269 | 270 |
| 271 | 272 | 273 | 274 | 275 | 276 | 277 | 278 | 279 | 280 | 281 | 282 | 283 | 284 | 285 | 286 | 287 | 288 | 289 | 290 | 291 | 292 | 293 | 294 | 295 | 296 | 297 | 298 | 299 | 300 |
| 301 | 302 | 303 | 304 | 305 | 306 | 307 | 308 | 309 | 310 | 311 | 312 | 313 | 314 | 315 | 316 | 317 | 318 | 319 | 320 | 321 | 322 | 323 | 324 | 325 | 326 | 327 | 328 | 329 | 330 |
| 331 | 332 | 333 | 334 | 335 | 336 | 337 | 338 | 339 | 340 | 341 | 342 | 343 | 344 | 345 | 346 | 347 | 348 | 349 | 350 | 351 | 352 | 353 | 354 | 355 | 356 | 357 | 358 | 359 | 360 |
| 361 | 362 | 363 | 364 | 365 | 366 | 367 | 368 | 369 | 370 | 371 | 372 | 373 | 374 | 375 | 376 | 377 | 378 | 379 | 380 | 381 | 382 | 383 | 384 | 385 | 386 | 387 | 388 | 389 | 390 |
| 391 | 392 | 393 | 394 | 395 | 396 | 397 | 398 | 399 | 400 | 401 | 402 | 403 | 404 | 405 | 406 | 407 | 408 | 409 | 410 | 411 | 412 | 413 | 414 | 415 | 416 | 417 | 418 | 419 | 420 |
| 421 | 422 | 423 | 424 | 425 | 426 | 427 | 428 | 429 | 430 | 431 | 432 | 433 | 434 | 435 | 436 | 437 | 438 | 439 | 440 | 441 | 442 | 443 | 444 | 445 | 446 | 447 | 448 | 449 | 450 |
| 451 | 452 | 453 | 454 | 455 | 456 | 457 | 458 | 459 | 460 | 461 | 462 | 463 | 464 | 465 | 466 | 467 | 468 | 469 | 470 | 471 | 472 | 473 | 474 | 475 | 476 | 477 | 478 | 479 | 480 |
| 481 | 482 | 483 | 484 | 485 | 486 | 487 | 488 | 489 | 490 | 491 | 492 | 493 | 494 | 495 | 496 | 497 | 498 | 499 | 500 | 501 | 502 | 503 | 504 | 505 | 506 | 507 | 508 | 509 | 510 |
| 511 | 512 | 513 | 514 | 515 | 516 | 517 | 518 | 519 | 520 | 521 | 522 | 523 | 524 | 525 | 526 | 527 | 528 | 529 | 530 | 531 | 532 | 533 | 534 | 535 | 536 | 537 | 538 | 539 | 540 |
| 541 | 542 | 543 | 544 | 545 | 546 | 547 | 548 | 549 | 550 | 551 | 552 | 553 | 554 | 555 | 556 | 557 | 558 | 559 | 560 | 561 | 562 | 563 | 564 | 565 | 566 | 567 | 568 | 569 | 570 |
| 571 | 572 | 573 | 574 | 575 | 576 | 577 | 578 | 579 | 580 | 581 | 582 | 583 | 584 | 585 | 586 | 587 | 588 | 589 | 590 | 591 | 592 | 593 | 594 | 595 | 596 | 597 | 598 | 599 | 600 |
| 601 | 602 | 603 | 604 | 605 | 606 | 607 | 608 | 609 | 610 | 611 | 612 | 613 | 614 | 615 | 616 | 617 | 618 | 619 | 620 | 621 | 622 | 623 | 624 | 625 | 626 | 627 | 628 | 629 | 630 |
| 631 | 632 | 633 | 634 | 635 | 636 | 637 | 638 | 639 | 640 | 641 | 642 | 643 | 644 | 645 | 646 | 647 | 648 | 649 | 650 | 651 | 652 | 653 | 654 | 655 | 656 | 657 | 658 | 659 | 660 |
| 661 | 662 | 663 | 664 | 665 | 666 | 667 | 668 | 669 | 670 | 671 | 672 | 673 | 674 | 675 | 676 | 677 | 678 | 679 | 680 | 681 | 682 | 683 | 684 | 685 | 686 | 687 | 688 | 689 | 690 |
| 691 | 692 | 693 | 694 | 695 | 696 | 697 | 698 | 699 | 700 | 701 | 702 | 703 | 704 | 705 | 706 | 707 | 708 | 709 | 710 | 711 | 712 | 713 | 714 | 715 | 716 | 717 | 718 | 719 | 720 |
| 721 | 722 | 723 | 724 | 725 | 726 | 727 | 728 | 729 | 730 | 731 | 732 | 733 | 734 | 735 | 736 | 737 | 738 | 739 | 740 | 741 | 742 | 743 | 744 | 745 | 746 | 747 | 748 | 749 | 750 |
| 751 | 752 | 753 | 754 | 755 | 756 | 757 | 758 | 759 | 760 | 761 | 762 | 763 | 764 | 765 | 766 | 767 | 768 | 769 | 770 | 771 | 772 | 773 | 774 | 775 | 776 | 777 | 778 | 779 | 780 |
| 781 | 782 | 783 | 784 | 785 | 786 | 787 | 788 | 789 | 790 | 791 | 792 | 793 | 794 | 795 | 796 | 797 | 798 | 799 | 800 | 801 | 802 | 803 | 804 | 805 | 806 | 807 | 808 | 809 | 810 |
| 811 | 812 | 813 | 814 | 815 | 816 | 817 | 818 | 819 | 820 | 821 | 822 | 823 | 824 | 825 | 826 | 827 | 828 | 829 | 830 | 831 | 832 | 833 | 834 | 835 | 836 | 837 | 838 | 839 | 840 |
| 841 | 842 | 843 | 844 | 845 | 846 | 847 | 848 | 849 | 850 | 851 | 852 | 853 | 854 | 855 | 856 | 857 | 858 | 859 | 860 | 861 | 862 | 863 | 864 | 865 | 866 | 867 | 868 | 869 | 870 |
| 871 | 872 | 873 | 874 | 875 | 876 | 877 | 878 | 879 | 880 | 881 | 882 | 883 | 884 | 885 | 886 | 887 | 888 | 889 | 890 | 891 | 892 | 893 | 894 | 895 | 896 | 897 | 898 | 899 | 900 |
| 901 | 902 | 903 | 904 | 905 | 906 | 907 | 908 | 909 | 910 | 911 | 912 | 913 | 914 | 915 | 916 | 917 | 918 | 919 | 920 | 921 | 922 | 923 | 924 | 925 | 926 | 927 | 928 | 929 | 930 |
| 931 | 932 | 933 | 934 | 935 | 936 | 937 | 938 | 939 | 940 | 941 | 942 | 943 | 944 | 945 | 946 | 947 | 948 | 949 | 950 | 951 | 952 | 953 | 954 | 955 | 956 | 957 | 958 | 959 | 960 |
| 961 | 962 | 963 | 964 | 965 | 966 | 967 | 968 | 969 | 970 | 971 | 972 | 973 | 974 | 975 | 976 | 977 | 978 | 979 | 980 | 981 | 982 | 983 | 984 | 985 | 986 | 987 | 988 | 989 | 990 |
| 991 | 992 | 993 | 994 | 995 | 996 | 997 | 998 | 999 | 1000 | 1001 | 1002 | 1003 | 1004 | 1005 | 1006 | 1007 | 1008 | 1009 | 1010 | 1011 | 1012 | 1013 | 1014 | 1015 | 1016 | 1017 | 1018 | 1019 | 1020 |
| 1021 | 1022 | 1023 | 1024 | 1025 | 1026 | 1027 | 1028 | 1029 | 1030 | 1031 | 1032 | 1033 | 1034 | 1035 | 1036 | 1037 | 1038 | 1039 | 1040 | 1041 | 1042 | 1043 | 1044 | 1045 | 1046 | 1047 | 1048 | 1049 | 1050 |
| 1051 | 1052 | 1053 | 1054 | 1055 | 1056 | 1057 | 1058 | 1059 | 1060 | 1061 | 1062 | 1063 | 1064 | 1065 | 1066 | 1067 | 1068 | 1069 | 1070 | 1071 | 1072 | 1073 | 1074 | 1075 | 1076 | 1077 | 1078 | 1079 | 1080 |
| 1081 | 1082 | 1083 | 1084 | 1085 | 1086 | 1087 | 1088 | 1089 | 1090 | 1091 | 1092 | 1093 | 1094 | 1095 | 1096 | 1097 | 1098 | 1099 | 1100 | 1101 | 1102 | 1103 | 1104 | 1105 | 1106 | 1107 | 1108 | 1109 | 1110 |
| 1111 | 1112 | 1113 | 1114 | 1115 | 1116 | 1117 | 1118 | 1119 | 1120 | 1121 | 1122 | 1123 | 1124 | 1125 | 1126 | 1127 | 1128 | 1129 | 1130 | 1131 | 1132 | 1133 | 1134 | 1135 | 1136 | 1137 | 1138 | 1139 | 1140 |
| 1141 | 1142 | 1143 | 1144 | 1145 | 1146 | 1147 | 1148 | 1149 | 1150 | 1151 | 1152 | 1153 | 1154 | 1155 | 1156 | 1157 | 1158 | 1159 | 1160 | 1161 | 1162 | 1163 | 1164 | 1165 | 1166 | 1167 | 1168 | 1169 | 1170 |
| 1171 | 1172 | 1173 | 1174 | 1175 | 1176 | 1177 | 1178 | 1179 | 1180 | 1181 | 1182 | 1183 | 1184 | 1185 | 1186 | 1187 | 1188 | 1189 | 1190 | 1191 | 1192 | 1193 | 1194 | 1195 | 1196 | 1197 | 1198 | 1199 | 1200 |

MAY
IRSD002

Please send me one year of BYTE Magazine for \$24.95 and bill me. Offer valid in U.S. and possessions only.

We've Invented the Future of Instrumentation Software . . . Twice.

With Words With Pictures

Acquisition

Integrated libraries for GPIB, RS-232, A/D-D/A-DIO plug-in cards, and modular instruments.

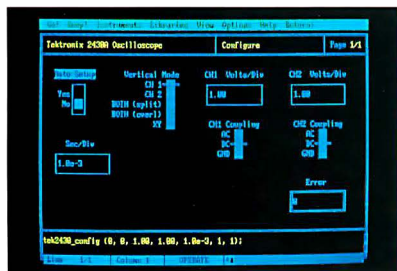

Intuitive character-based function panels that automatically generate source code.

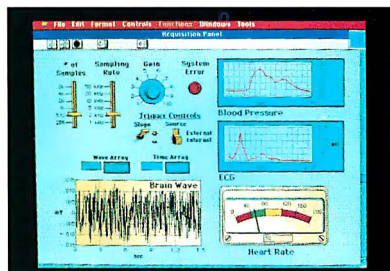

Front panel user interface with virtual instrument block diagram programming.

Analysis

Extensive libraries for data reduction, digital signal processing, and statistical analysis.



Over 100 analysis functions plus all the built-in functions of your language.

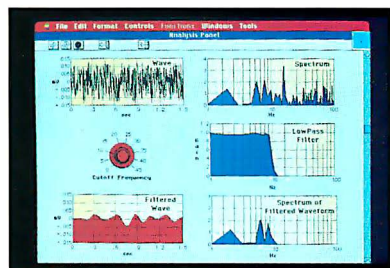

Over 250 icons for computation and analysis.

Presentation

Flexible high-performance graphics and report generation.

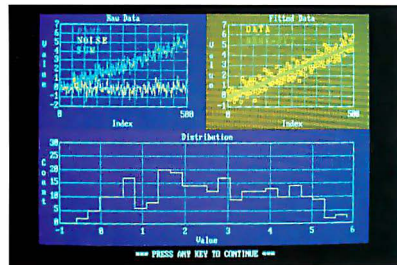

Extensive graphics support for CGA, EGA, MCGA, VGA, and Hercules.

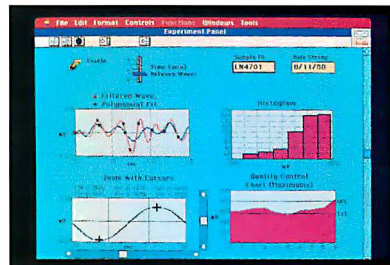

Macintosh Desktop Publishing compatibility.



12109 Technology Boulevard
Austin, Texas 78727-6204
800/531-4742 512/250-9119

LabWindows[®]
for the DOS-based PC and PS/2,
with Microsoft QuickBASIC or C.

LabVIEW[®]
for the Apple Macintosh.

National Instruments of Japan 81 (03) 788-1921 • National Instruments of France (1) 48 65 33 70 • National Instruments United Kingdom 44-01-549-3444 • ARGENTINA 541/46-5776 /0628
• AUSTRALIA 61 (3) 879-2322 • BELGIUM 02-735.21.35 • CANADA 416/890-2010 613/596-9300 (514) 747-7878-403/295-0822 (604) 988-2195 • CHILE 56 2253689 • DENMARK 45 02-251122
• FINLAND 35890-372 144 • FRANCE 33 (1) 69077802 • HONG KONG 852 0-262707-852 0-262945 • IRELAND 353 042 72282 • ISRAEL 972 324298 • ITALY 39-2-98491071-2-3 • KOREA (02) 776-38
• MEXICO 52 660 4323 • THE NETHERLANDS 31 070-996360 • NEW ZEALAND 64 09 444-2645 • NORWAY 02-531250 • PORTUGAL 19545313 • SINGAPORE 65 29 11336
• SOUTH AFRICA 27(011) 787-0473 • SPAIN 34 (1) 455 81 12 • SWEDEN 4608 792 11 00 • SWITZERLAND 41 6552 8949 • TAIWAN THE REPUBLIC OF CHINA 886(02) 7036280 • THAILAND 66 2349330
• UNITED KINGDOM 44 273 608 331 • WEST GERMANY 49 89 807081

Circle 313 on Reader Service Card for LabWindows.
314 for LabVIEW.

Tandy Computers: The broadest line of PCs in America.



The Tandy[®] 4000 LX

Get the power
and performance
of Intel's 80386
...at 20 MHz.

To streamline your heavy business workload, turn to the Tandy 4000 LX. With its 32-bit Intel[®] 80386 microprocessor operating at 20 MHz, the 4000 LX delivers a new level of performance to database management and sophisticated computer-aided design.

Two megabytes of zero wait-state memory make the 4000 LX ready to use with MS[®] OS/2, as well as MS-DOS[®] software. With this much memory standard, the Tandy 4000 LX is also ready to use as the

hub of a powerful multiuser office system running SCO[™] XENIX[®] software. And as a network file server in a 3Com[®] workgroup, the 4000 LX provides 20 MHz performance for exceptionally high-speed data transfer.

The Tandy 4000 LX is highly expandable. Three front-panel device slots and eight expansion slots give power users the flexibility needed in configuring the optimum system. VGA graphics for desktop publishing, an Intel 80387 math

coprocessor for math-intensive applications and SCSI technology for high-performance disk storage are but a few of the many expansion options available.

The Tandy 4000 LX complements our Tandy 4000—a 386[™] machine operating at 16 MHz. The 1MB Tandy 4000 is the cost-effective solution for many high-performance applications.

The new generation Tandy 4000 LX. From the best-selling family of PC compatibles made in America.

Tandy Computers: Because there is no better value[™]

Intel/Reg. TM and 386/TM Intel Corp. MS, MS-DOS and XENIX/Reg. TM Microsoft Corp. SCO/TM The Santa Cruz Operation. 3Com/Reg. TM 3Com Corp.

Radio Shack[®]
COMPUTER CENTERS
A DIVISION OF TANDY CORPORATION

Circle 230 on Reader Service Card