

Inside: Bonus Graphics Supplement (follows page 248)

BYTE

APRIL 1989

A MCGRAW-HILL PUBLICATION

REVIEWS

Wells American
CompuStar 286
2 Color Scanners
Extend
Mac Presentation
Software

PRODUCT FOCUS



BYTE Lab Tests
12 UPSes

33 MHz

*SIA's new 386/32
33-MHz rated, 32.5-MHz clock,
special cooling, fast caching*

IN DEPTH

CASE

PLUS

Discus Rewritable
TRON
Sharp Wizard
PhotoMac

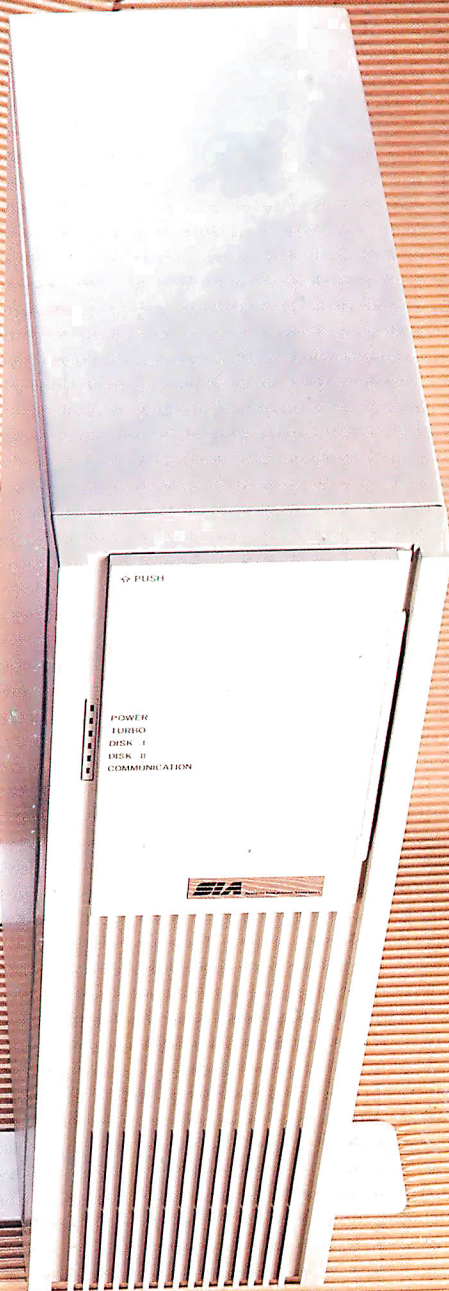

\$3.50 U.S.A./\$4.50 IN CANADA
0360-5280

0 440235 0

Technically speaking, the System 325 is the most advanced 386™ computer we've ever built. And, according to PC Magazine, it's one of the most advanced 386 computers they've ever tested.

In benchmark after benchmark, the Dell System 325 25 MHz ran circles around a field

A PERSONAL COMPUTER THAT'S REALLY PERSONAL.

Of the more than 150,000 personal computers we've sold to date, each one's been individually configured to fit the needs of its owner.

The System 325 takes that idea

to its logical extreme.

For example, it runs either MS-DOS®, OS/2, or our own Dell UNIX® System V. Which is compatible with AT&T's System V Interface Definition. And the world of XENIX® applications.

If speed is of the essence, we can include an optional Intel^

**THE DELL 386 SYSTEM 325
HAS A 25 MHz CLOCK RATE,
CACHE MEMORY CONTROLLER,
90 MB 18ms ESDI DRIVE,
PAGE MODE INTERLEAVED MEMORY,
AND 100% COMPATIBILITY WITH
MS-DOS, OS/2 AND UNIX SYSTEM V.**

of 386-based systems. A field that included the Compaq^ 386/25.

A show of prowess that earned the System 325 PC Magazine's Editor's Choice award.

It was a goal we set for ourselves from the very beginning. And an objective anyone with a penchant for power and performance can appreciate.



80387 or WEITEK 3167 math coprocessor. And since nothing about this system is lightweight, the standard mass storage is a 90 MB ESDI disk drive. Or we can configure it with a 150 or 322 MB unit.

As you might expect, the output is just as intense. You can choose between VGA mono with paperwhite screen, or VGA Color

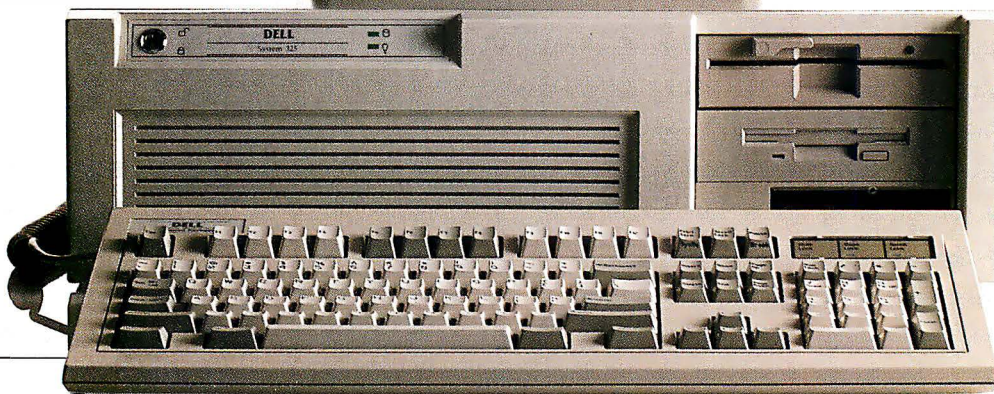

DOT MATRIX PRINTERS.

Printer System 800: \$699.95
Our highest resolution text and graphics, 24-pin dot matrix printer. Draft quality at 200 cps. Letter quality at 66 cps. Parallel and serial interfaces. Wide carriage.

Printer System 600: \$499.95
9-pin dot matrix. Draft quality at 240 cps. Near-letter quality at 60 cps. Parallel interface. Wide carriage.

Printer System 300: \$199.95
9-pin dot matrix. Draft quality at 144 cps. Near-letter quality at 36 cps. Four standard fonts. Parallel interface. Narrow carriage.

LASER PRINTERS.



SO HOW COME YOU NEVER CALL?

THE DELL SYSTEM 325 25 MHz 386

STANDARD FEATURES:

- Intel 80386 microprocessor running at 25 MHz.
- Choice of 1 MB or 4 MB of RAM* expandable to 16 MB using a dedicated high speed 32-bit memory slot.
- Advanced Intel 82385 Cache Memory Controller with 32 KB of high speed static RAM cache.
- Page mode interleaved memory architecture.
- VGA systems include a high performance 16-bit video adapter.
- Socket for 25 MHz Intel 80387 or 25 MHz WEITEK 3167 math coprocessor.
- 5.25" 1.2 MB or 3.5" 1.44 MB diskette drive.
- Dual diskette and hard disk drive controller.
- Enhanced 101-key keyboard.
- 1 parallel and 2 serial ports.
- 200-watt power supply.
- 8 industry standard expansion slots.

OPTIONS:

- 25 MHz Intel 80387 math coprocessor.
- 25 MHz WEITEK 3167 math coprocessor
- 1 MB or 4 MB RAM upgrade kit.
- 2 MB or 8 MB memory expansion board kit.

**Lease for as low as \$228/Month.

System 325	With Monitor & Adapter			
	VGA Mono		VGA Color Plus	
Hard Disk Drives	1MB RAM	4MB RAM	1MB RAM	4MB RAM
90 MB-18 ms ESDI	\$6,299	\$ 7,599	\$6,599	\$ 7,899
150 MB-18 ms ESDI	\$6,799	\$ 8,099	\$7,099	\$ 8,399
322 MB-18 ms ESDI	\$8,799	\$10,099	\$9,099	\$10,399

Disclaimer: All systems are photographed with optional extras, which some computer retailers won't even recognize.



Laser System 150, 15 pages per minute: \$5,995.
 Laser System 80, 8 pages per minute: \$3,295.
 Laser System 60, 6 pages per minute: \$2,195.

All Dell laser printers come with 1.5 MBRAM, full-page 300 DPI graphics, and have 31 standard fonts (7 resident and 24 downloadable from diskette).

Dell laser printers also provide Hewlett-Packard LaserJet Plus[®], Epson/FX[®], IBM Proprinter[®] and Diablo 630[®] emulations.

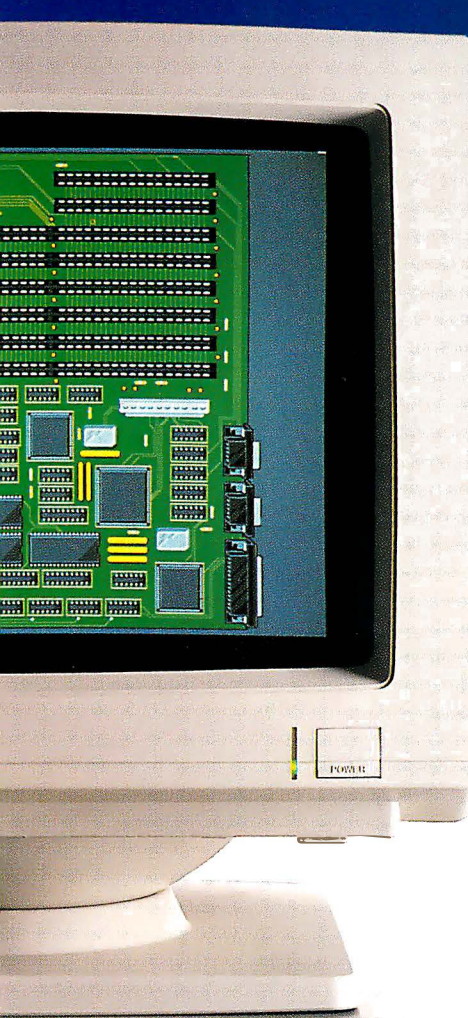

THE DELL SYSTEM 310
20 MHz 386.

The best combination of performance and value available.

STANDARD FEATURES:

- Intel 80386 microprocessor running at 20 MHz.
- Choice of 1 MB or 4 MB of RAM* expandable to 16 MB using a dedicated high speed 32-bit memory slot.
- Advanced Intel 82385 Cache Memory Controller with 32 KB of high speed static RAM cache.
- Page mode interleaved memory architecture.
- VGA systems include a high performance 16-bit video adapter.
- Socket for 20 MHz Intel 80387 or 20 MHz WEITEK 3167 math coprocessor.
- 5.25" 1.2 MB or 3.5" 1.44 MB diskette drive.
- Dual diskette and hard disk drive controller.
- Enhanced 101-key keyboard.
- 1 parallel and 2 serial ports.
- 200-watt power supply.
- 8 industry standard expansion slots.

OPTIONS:

- 20 MHz Intel 80387 math coprocessor.
- 20 MHz WEITEK 3167 math coprocessor.
- 1 MB or 4 MB RAM upgrade kit.
- 2 MB or 8 MB memory expansion board kit.

**Lease for as low as \$141/Month.

System 310 With Monitor & Adapter

Hard Disk Drives	VGA Mono		VGA Color Plus	
	1 MB RAM	4 MB RAM	1 MB RAM	4 MB RAM
40 MB-28 ms	\$3,899	\$5,199	\$4,199	\$5,499
90 MB-18 ms ESDI	\$4,699	\$5,999	\$4,999	\$6,299
150 MB-18 ms ESDI	\$5,199	\$6,499	\$5,499	\$6,799
322 MB-18 ms ESDI	\$7,199	\$8,499	\$7,499	\$8,799



THE DELL SYSTEM 220
20 MHz 286.

It's fast as most 386 computers. But at less than half the price. The footprint is small, too.

STANDARD FEATURES:

- 80286 microprocessor running at 20 MHz.
- 1 MB of RAM* expandable to 16 MB (8 MB on system board).
- Page mode interleaved memory architecture.
- LIM 4.0 support for memory over 1 MB.
- Integrated diskette and VGA video controller on system board.
- Socket for Intel 80287 math coprocessor.
- One 3.5" 1.44 MB diskette drive.
- Integrated high performance hard disk interface on system board.
- Enhanced 101-key keyboard.
- 1 parallel and 2 serial ports (integrated on system board).
- 3 full-sized industry standard expansion slots available.

OPTIONS:

- External 5.25" 1.2 MB diskette drive.
- 3.5" 1.44 MB diskette drive.
- Intel 80287 math coprocessor.
- 1 MB or 4 MB RAM upgrade kit.

**Lease for as low as \$86/Month.

System 220 With Monitor

Hard Disk Drives	VGA Mono		VGA Color Plus	
	One Diskette Drive	40 MB-29 ms	100 MB-29 ms	Hard Disk
40 MB-29 ms	\$2,299	\$2,999	\$2,999	\$3,299
100 MB-29 ms	\$3,799	\$4,499	\$4,499	\$4,799



THE DELL SYSTEM 200
12.5 MHz 286.

This full-featured 286 computer runs at 12.5 MHz, and is completely Microsoft MS-DOS and MS OS/2 compatible.

STANDARD FEATURES:

- 80286 microprocessor running at 12.5 MHz.
- 640 KB of RAM expandable to 16 MB (4.6 MB on system board).
- Socket for Intel 80287 math coprocessor.
- 5.25" 1.2 MB or 3.5" 1.44 MB diskette drive.
- Dual diskette and hard disk drive controller.
- Enhanced 101-key keyboard.
- 1 parallel and 2 serial ports.
- 200-watt power supply.
- 6 industry standard expansion slots.

OPTIONS:

- Intel 80287 math coprocessor.
- 512 KB RAM upgrade kit.
- 2 MB RAM upgrade kit.

**Lease for as low as \$93/Month.

System 200 With Monitor & Adapter

Hard Disk Drive	VGA Mono		VGA Color Plus	
	40 MB-40 ms	40 MB-28 ms	90 MB-18 ms ESDI	150 MB-18 ms ESDI
40 MB-40 ms	\$2,499	\$2,799	\$3,499	\$3,799
90 MB-18 ms ESDI	\$3,499	\$3,799	\$4,999	\$5,299
150 MB-18 ms ESDI	\$3,999	\$4,299	\$5,999	\$6,299

*Performance enhancements (Systems 325, 310 and 220): Within the first megabyte of memory, 384 KB of memory is reserved for use by the system to enhance performance.



APPLICATION SOFTWARE.

We offer a complete line of software. Everything from complex CAD/CAM applications to fun flight simulator programs. All at extremely competitive prices.

OPERATING SYSTEM SOFTWARE.

- Dell Enhanced Microsoft[®] MS-DOS[®] 3.3: \$99.95
- Dell Enhanced Microsoft MS-DOS 4.0: \$119.95
(Both MS-DOS versions with disk cache and other utilities.)
- Dell Enhanced MS[®] OS/2 Standard Edition 1.0: \$324.95
- Dell UNIX[®] System V/386, Release 3.2: Available 3/31/89. Call for details.

All prices and specifications are subject to change without notice. Dell cannot be responsible for errors in typography or photography. **Payments based on a 36-month open-end lease. In Canada, configurations and prices will vary. Microsoft, MS, MS-DOS and XENIX are registered trademarks owned by Microsoft Corp. 386 is a trademark of Intel Corporation. UNIX is a registered trademark of AT&T. *Signifies trademarks of entities other than Dell Computer Corporation. ^Service in remote locations will incur additional travel charges. © 1989 DELL COMPUTER CORPORATION.

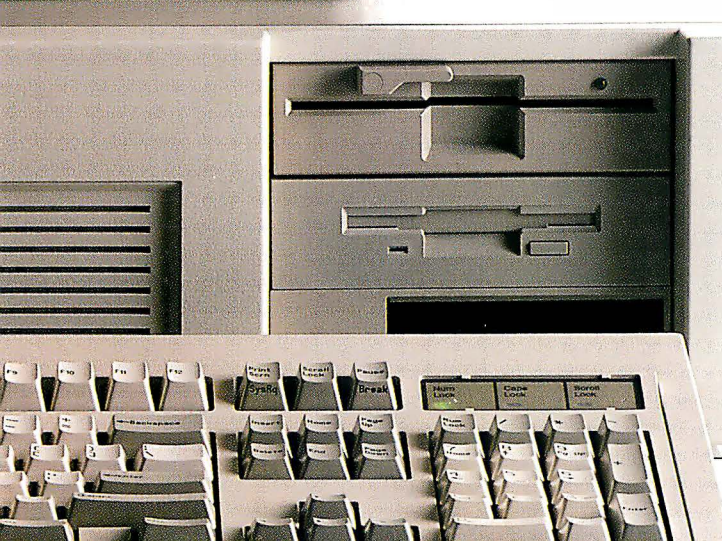

Plus, for high resolution colors displayed on a larger screen.

Even though the 325 gives you all this performance, it still leaves you six open slots for whatever you might want to add.

And once you've told us what you want, we'll make sure what you want works—by burning in the entire system unit.

COMPUTER RETAILERS ARE NO KNOWS.

In all probability, the average computer retailer won't have any understanding what makes the System 325 go.

He will, however, be quite aware of the fact that he could add a 35% markup if he could sell it in his store.

Which he can't.

Because we sell direct.

Meaning you now have the unique opportunity to talk directly with a computer expert. And ask things like, "What's the difference between IDE and ESDI?" Or, "How much SIMM RAM should I add?"

In other words, the kinds of questions you should be able to ask a retailer, but usually can't.

So as you might suspect, dealing direct not only saves you the 35% markup, but 100% of the aggravation.

DELL
COMPUTER
CORPORATION

Marty Brandt
Account Representative

5005 ARBORETUM BLVD., AUSTIN, TEXAS 78759-7229
FAX 0600 727-6320 TEL 0800 426-5150



WE COME WHEN WE'RE CALLED.

One of the things that very clearly sets a Dell system apart

from other computers is not just how they're sold, but how they're supported.

Overkill was one description used in a recent PC Week article. Perhaps.

But then, we think you'll agree, when something goes wrong, you want as much help as

MAYBE YOU SHOULDN'T BUY ONE AFTER ALL.

No matter how many reasons we give you to buy a Dell system, sometimes it makes more sense to lease one instead.

Whether you need a single computer, or an entire office full,

BEST OF ALL, YOU WON'T HAVE TO EXPLAIN TO A COMPUTER RETAILER WHAT ALL THAT MEANS.

possible, right?

Which is why every Dell system comes with a toll-free technical support line and self-diagnostic software. We're able to solve 90% of all problems right over the phone. The other 10% receive next-day, desk-side service.

And you get all this help for a full year—whenever you need it—at no extra charge.△

As you've probably guessed, one of the things that drives us most is customer satisfaction.

So we'd like to give you the ultimate guarantee: Try a System 325 in your office for a month. Run your toughest applications. Put it through its paces, at your pace. If you're not completely satisfied, send it back anytime within 30 days. And we'll refund your money.

No questions asked.

our leasing plan is just like 100% financing. So you don't tie up working capital. Or credit lines.

Of course, there can be tax advantages as well.

And just as we can custom configure your computers, we can fit a lease plan to the exact needs of your business. A fact that has not gone unnoticed. Especially by the Fortune 500. Over half of whom now own or lease Dell systems.

We welcome your business, too. Just call us, toll-free. And don't be afraid to ask us the tough questions.

That's the part we like best.

DELL
COMPUTER
CORPORATION

TO ORDER, CALL
800-426-5150

IN CANADA, CALL 800-387-5752
IN GERMANY, CALL 06103/701100
IN THE U.K., CALL 0800 414535

BYTE

APRIL 1989

VOL. 14/NO. 4

PRODUCTS IN PERSPECTIVE

- 65 What's New**
- 97 Short Takes**
SideKick for Presentation Manager, Borland's program is more than just a pretty face
PhotoMac, industrial-strength color processing from Data Translation
Wizard, Sharp's electronic organizer
Discus Rewritable, Advanced Graphics Applications' new optical disk drive
DOSTALK, a natural-language interface for MS-DOS from SAK Technologies

REVIEWS

- 170 Product Focus:**
Curing the Brownout Blues
by Steve Apiki, Stanford Diehl, and Rick Grehan
A look at uninterruptible power systems that will help you sleep better at night.



COVER STORY

FIRST IMPRESSIONS

32.5 MHz and Climbing by Steve Apiki page 106

Rated for 33MHz and running at 32.5 MHz, SIA's 386/32 defines a new plateau.

- 179 High-Tech Computing, Cafeteria Style**
by Mark L. Van Name
Wells American's CompuStar offers performance in a custom-ordered tower design.
- 189 Full-Spectrum Scanners**
by Tom Thompson
The Sharp JX-450 and the Howtek Scanmaster let you import color images quickly, easily, and affordably.
- 197 Extend**
by Ray Valdés
An object-oriented simulation toolkit for the Mac from Imagine That!
- 203 Mac Desktop Presentation Software**
by Lawrence Stevens
Cricket Software's Cricket Presents, Letraset's StandOut!, and Microsoft's PowerPoint help you create winning presentations.

EXPERT ADVICE

- 111 Computing at Chaos Manor: Language Sojourn**
by Jerry Pournelle
Jerry explores the highways and byways of programming choices.
- 129 Applications Plus: Answers to My Mac Mess**
by Ezra Shapiro
Readers rise to defend the Mac and offer solutions to system snafus.
- 135 Down to Business: Groping for Groupware**
by Wayne Rash Jr.
These packages of group productivity software might make life a bit less complicated.

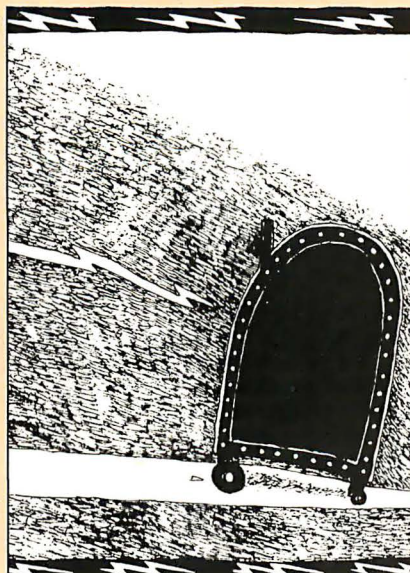

- 141 Macinations: Smalltalk Can Be Cheap**
by Don Crabb
A new version of Smalltalk/V for the Mac could give Smalltalk-80 a run for its money.
- 151 COM1: E-Mail Economics**
by Brock N. Meeks
Don't measure E-mail services by their costs alone.
- 157 OS/2 Notebook: OS/2 for Cheap**
by Mark Minasi
Mark presents part 2 of the inexpensive OS/2 workstation project.



◀ **SPECIAL SECTION:**
Graphics Supplement/249

IN DEPTH

- 206 Introduction: CASE**
- 209 The CASE Philosophy**
by Michael Lucas Gibson
The whole picture involves integrating corporate plans, systems design, and systems development into one system.
- 221 Methodology: The Experts Speak**
by Ken Orr, Chris Gane, Edward Yourdon, Peter P. Chen, and Larry L. Constantine
Noted software engineers discuss the methodologies they helped develop.
- 235 The CASE Experience**
by Carma McClure
CASE works. But do you need a tool, a toolkit, or a workbench? And how do you begin?
- 246 A CASE Workshop**
by Carma McClure
A sampling of the many fine CASE tools that are available today.



CASE/206

HANDS ON

- 303 Under the Hood: The IBM PC BIOS**
by Brett Glass
Knowing what goes on inside the BIOS is the key to making a system IBM PC-compatible.
- 311 Some Assembly Required: Floating-Point Revisited**
by Rick Grehan
A floating-point package that's well suited to business applications.

DEPARTMENTS

- 6 Editorial:**
Open Everything
- 11 Microbytes**
- 24 Letters and Ask BYTE**
- 45 Chaos Manor Mail**
- 51 Book Reviews**
- 356 Coming Up in BYTE**

READER SERVICE

- 355 Editorial Index by Company**
- 357 Alphabetical Index to Advertisers**
- 359 Index to Advertisers by Product Category**
Inquiry Reply Cards: after **360**

PROGRAM LISTINGS

- From BIX: see **290**
- From BYTEnet:
call (617) 861-9764
- On disk or in print:
see card after **304**

FEATURES

- 292 The TRON Project**
by Ken Sakamura and Richard Sprague
Will a unique operating system, chips, and software change the way we use computers?



TRON/292

BYTE (ISSN 0360-5280) is published monthly with an additional issue in October by McGraw-Hill, Inc. Postmaster: Send address changes, USPS Form 3579, and fulfillment questions to BYTE Subscriptions, P.O. Box 551, Hightstown, NJ 08520. Second-class postage paid at Peterborough, NH 03458, and additional mailing offices. Postage paid at Winnipeg, Manitoba. Registration number 9321. Printed in the United States of America.

Not responsible for lost manuscripts or photos. Opinions expressed by the authors are not necessarily those of BYTE.

Copyright © 1989 by McGraw-Hill, Inc. All rights reserved. Trademark registered in the United States Patent and Trademark Office.



Subscription questions or problems should be addressed to: BYTE Subscriber Service, P.O. Box 551, Hightstown, NJ 08520.

BYTE

EDITOR IN CHIEF
Frederic S. Langa

PUBLISHER/GROUP VICE PRESIDENT
J. Burt Totaro

OPERATIONS
Glenn Hartwig *Associate Managing Editor*

REVIEWS (Hardware, Software, Product Focus)
Michael Nadeau, *Associate Managing Editor*, Dennis Allen *Senior Technical Editor*, Software, Richard Grehan *Director*, BYTE Lab, Stephen Apiki *Testing Editor*, BYTE Lab, Stanford Diehl *Testing Editor*, BYTE Lab

NEWS AND TECHNOLOGY (Microbytes, What's New, Short Takes)
Rich Malloy *Associate Managing Editor*, D. Barker *Senior Editor*, News and Technology, Anne Fischer *Lent Senior Editor*, New Products, Andrew Reinhardt *Associate News Editor*

Peterborough: Roger Adams *Associate News Editor*, David Andrews *Associate News Editor*, Martha Hicks *Associate News Editor*

West Coast: Gene Smarte *Special Projects*, Costa Mesa, Nicholas Baran *Senior Editor*, San Francisco, Frank Hayes *Associate News Editor*, Marlene Nesary *Associate News Editor*, Jeffrey Bertolucci *Editorial Assistant*, San Francisco

SENIOR TECHNICAL EDITORS
Ken Sheldon *Features*, Jane Morrill Tazelaar *In Depth*, Tom Thompson *At Large*

TECHNICAL EDITORS
Janet J. Barron, Robert Mitchell, Ben Smith, Jon Udell, Stanley Wszola

CONSULTING EDITORS
Jerry Pournelle, Ezra Shapiro, Don Crabb, Brett Glass, Brock N. Meeks, Mark Minasi, Wayne Rash Jr.

CONTRIBUTING EDITORS
Jonathan Amsterdam *Programming Projects*, Mark Dahmke *Video*, *Operating Systems*, Mark Haas *At Large*, Rik Jadrnick *CAD*, *Graphics*, *Spreadsheets*, Robert T. Kurosaka *Mathematical Recreations*, Alastair J. W. Mayer *Software*, Stan Miastkowski *New Technology*, Alan R. Miller *Languages and Engineering*, Dick Pountain *Algorithms*, Roger Powell *Computers and Music*, Phillip Robinson *Semiconductors*, Jon Shiell *High-Performance Systems*, George A. Stewart, *Book Reviews*, Ernest Tello *Artificial Intelligence*

COPY EDITORS
Lauren Stickler *Chief*, Susan Colwell, Jeff Edmonds, Judy Grehan, Nancy Hayes, Cathy Kingery, Margaret A. Richard, Warren Williamson

EDITORIAL ASSISTANTS
Peggy Dunham *Office Manager*, Linda C. Ryan, June N. Sheldon, Lynn Susan Valley

ART
Nancy Rice *Director*, Joseph A. Gallagher *Assistant Director*, Lisa Lynch *Assistant*, Jan Muller *Assistant*, Alan Easton *Technical Artist*

PRODUCTION
David R. Anderson *Director*, Virginia Reardon *Senior Editorial Production Coordinator*, Barbara Busenbark *Editorial Production Coordinator*, Denise Chartrand *Editorial Production Coordinator*, Michael J. Lonsky *Editorial Production Coordinator*

TYPOGRAPHY
Sherry Fiske *Systems Manager*, Donna Sweeney *Applications Manager*, Christa Patterson

ADVERTISING/PRODUCTION (803) 924-6448
Lisa Wozmak *Director of Advertising Services*, Lyda Clark *Senior Account Coordinator*, Karen Cilley, Linda Fluh, Jui Chiu Li *Quality Control Manager*, Rod Holden, Julie Murphree *Creative Services Manager*, Jeanne Gatcombe

EDITORIAL AND BUSINESS OFFICE:
One Phoenix Mill Lane, Peterborough, NH 03458, (603) 924-9281.
West Coast Branch Offices: 425 Battery St., San Francisco, CA 94111, (415) 954-9718; 3001 Red Hill Ave., Building #1, Suite 222, Costa Mesa, CA 92626, (714) 557-6292.
New York Branch Editorial Office: 1221 Avenue of the Americas, New York, NY 10020, (212) 512-3175.
BYTEnet: (617) 861-9764 (set modem at 8-1-N or 7-1-E; 300 or 1200 baud).
Fax: (603) 924-7507. **Telex:** (603) 924-7861.
SUBSCRIPTION CUSTOMER SERVICE: Outside U.S. (609) 426-7070; inside U.S. (800) 525-5003.
For a new subscription—(800) 257-9402 U.S. only, or write to BYTE Subscription Dept., P.O. Box 555, Hightstown, NJ 08520.

Officers of McGraw-Hill Information Services Company: President: Walter D. Serwatka. Executive Vice Presidents: Kenneth E. Gazzola, Aerospace and Defense; Ira Herenstein, Computers and Communications; Russell C. White, Construction; Robert P. McGraw, Healthcare; Brian H. Hall, Legal. Senior Vice Presidents—Publishers: Laurence Altman, Data Communications; David J. McGrath, Engineering News-Record. Senior Vice Presidents: Robert D. Daleo, Finance; Michael J. Koeller, Human Resources. Group Vice Presidents: J. Burt Totaro, BYTE; Norbert Schumacher, Energy/Process Industries. Vice Presidents: George Elsing, Circulation; Julia Lenard, Systems Planning and Technology.
Officers of McGraw-Hill, Inc.: Joseph L. Dionne, Chairman, President, and Chief Executive Officer; Robert N. Landes, Executive Vice President, General Counsel, and Secretary; Robert J. Bahash, Executive Vice President and Chief Financial Officer; Frank D. Penglase, Senior Vice President, Treasury Operations.

ADMINISTRATION
Donna Nordlund, *Publisher's Assistant*

MARKETING AND PLANNING
Michele Perron, *Director*
Faith Kluntz *Copyrights Coordinator*, Cynthia Damato *Sands Reader Service Coordinator*
Horace T. Howland *Director of Marketing Communications*, Pamela Petrakos-Wilson *Promotion Manager*, Wilbur S. Watson *Marketing Services Manager*, Dawn Matthews *Public Relations Manager*, Lisa Jo Steiner *Assistant Promotion Manager*, Stephanie Warnesky *Marketing Art Director*, Sharon Price *Associate Art Director*, Julie Perron *Market Research Analyst*

FINANCIAL SERVICES
Philip L. Penny *Director of Finance and Services*, Kenneth A. King *Business Manager*, Marilyn Parker, Diane Henry, JoAnn Walter, Jaime Huber

CIRCULATION
Dan McLaughlin *Director*
James Bingham *Newsstand Sales Manager*, Vicki Weston *Assistant Manager*, Karen Desroches *Distribution Coordinator*, Donna Healy, *Direct Accounts Coordinator*, Louise Menegus *Back Issues*

PERSONNEL
Patricia Burke *Personnel Coordinator*, Beverly Goss *Receptionist*

BUILDING SERVICES
Tony Bennett *Manager*, Cliff Monkton, Mark Monkton, Agnes Perry

BIX BYTE INFORMATION EXCHANGE

DIRECTOR
Stephen M. Laiberte

EXECUTIVE EDITOR
George Bond

MANAGING EDITOR
Tony Lockwood

MICROBYTES DAIRY
D. Barker *Coordinator*, Peterborough, Rich Malloy *New York*, Gene Smarte *Costa Mesa*, Nicholas Baran *San Francisco*, Rick Cook *Phoenix*, Frank Hayes *San Francisco*, Martin Heller, *Boston*, Jason Levitt *Austin, TX*, Larry Loeb *Wallingford, CT*, Brock N. Meeks *San Francisco*, Stan Miastkowski *Peterborough*, Wayne Rash Jr., Sue Rosenberg *Washington, DC*, David Reed *Lexington, KY*

GROUP MODERATORS
David Allen *Applications*, Leroy Casterline *Other*, Marc Greenfield *Programming Languages*, Jim Howard *Graphics*, Gary Kendall *Operating Systems*, Steve Krenek *Computers*, Brock N. Meeks *Telecommunications*, Barry Nance *New Technology*, Donald Osgood *Computers*, Sue Rosenberg *Other*, Jon Swanson *Chips*

EXCHANGE EDITOR
Larry Loeb, *Macintosh Exchange Editor*

BUSINESS AND MARKETING
Patricia Bausum *Secretary*, Denise A. Greene *Customer Service*, Brian Warnock *Customer Service*, Tammy Burgess *Customer Credit and Billing*

TECHNOLOGY
Clayton Lisle *Director*, *Business Systems Technology*, ISCO., John Spadafora *Programmer/Analyst*, Wayne Power, *Senior Business Systems Analyst*

ADVERTISING SALES
Steven M. Vito *Associate Publisher*, *Vice President of Marketing*

Sara Lyon *Administrative Assistant*

Jennifer L. Bartel *West Coast Sales Manager*, (214) 644-1111

NEW ENGLAND
ME, NH, VT, MA, RI, ONTARIO, CANADA & EASTERN CANADA
John C. Moon (617) 262-1160

ATLANTIC
NY, NYC, CT, NJ (NORTH)
Leah G. Rabinowitz (212) 512-2096
Ken Tashly (212) 512-2645

EAST
PA, KY, NJ (SOUTH), MD, W.VA, DE, DC
Thomas J. Brun (215) 496-3833

SOUTHEAST
NC, SC, GA, FL, AL, TN, VA, MS
Thomas H. Tolbert (404) 252-0626

MIDWEST
IL, MO, KS, IA, ND, SD, MN, WI, NE, IN, MI, OH
Kurt Kelley (312) 751-3740

SOUTHWEST, ROCKY MOUNTAIN
CO, WY, OK, TX, AR, LA
Karl Heinrich (713) 462-0757

SOUTH PACIFIC
SOUTHERN CA, AZ, NM, LAS VEGAS, UT
Ron Cordek (714) 557-6292
Tom Harvey (213) 480-5243

NORTH PACIFIC
HI, WA, OR, ID, MT, NORTHERN CA, NV (except LAS VEGAS), WESTERN CANADA
Bill McAfee (408) 879-0371
Christine Kocpek (415) 362-4600

TELEMARKETING
L. Bradley Browne *Director*
Susan Boyd *Administrative Assistant*

NATIONAL SALES
Liz Coyman (603) 924-2518
Dan Harper (603) 924-2598
Elisa Lister (603) 924-2598

BYTE BITS (2x3)
Mark Stone (603) 924-6830

THE BUYER'S MART (1x2)
Brian Higgins (603) 924-3754

REGIONAL ADVERTISING SECTIONS
Scott Gagnon (603) 924-4380
Larry Levine (603) 924-4379
Barry Echavarría (603) 924-2574

BYTE POSTCARD DECK MAILINGS

BYTE DECK
Ed Ware (603) 924-6166

COMPUTING FOR DESIGN & CONSTRUCTION
COMPUTING FOR ENGINEERS
Mary Ann Goulding (603) 924-9281

INTERNATIONAL ADVERTISING SALES STAFF
See listing on page 358.

Founder: James H. McGraw (1860-1948). Executive, editorial, circulation, and advertising offices: One Phoenix Mill Lane, Peterborough, NH 03458, phone (603) 924-9281. Office hours: Monday through Thursday 8:30 AM-4:30 PM, Friday 8:30 AM-1:00 PM, Eastern Time. Address subscriptions to BYTE: Subscriptions, P.O. Box 551, Hightstown, NJ 08520. Subscriptions are \$29.95 for one year, \$54.95 for two years, and \$74.95 for three years in the U.S. and its possessions. In Canada and Mexico, \$31.95 for one year, \$59.95 for two years, \$79.95 for three years. \$75 for one-year air delivery to Europe. \$28,800 for one-year air delivery to Japan, \$14,400 for one-year surface delivery to Japan, \$45 surface delivery elsewhere. Air delivery to selected areas at additional rates upon request. Single copy price is \$3.50 in the U.S. and its possessions, \$3.95 in Canada, \$4.50 in Europe, and \$5 elsewhere. Foreign subscriptions and sales should be remitted in U.S. funds drawn on a U.S. bank. Please allow six to eight weeks for delivery of first issue. Address editorial correspondence to: Editor, BYTE, One Phoenix Mill Lane, Peterborough, NH 03458. Unacceptable manuscripts will be returned if accompanied by sufficient postage. Where necessary, permission is granted by the copyright owner for libraries and others registered with the Copyright Clearance Center (CCC) to photocopy any article herein for the flat fee of \$1.50 per copy of the article or any part thereof. Correspondence and payment should be sent directly to the CCC, 29 Congress St., Salem, MA 01970. Specify ISSN 0360-5280/83, \$1.50. Copying done for other than personal or internal reference use without the permission of McGraw-Hill, Inc., is prohibited. Requests for special permission or bulk orders should be addressed to the publisher. BYTE is available in microform from University Microfilms International, 300 North Zeeb Rd., Dept. PR, Ann Arbor, MI 48106 or 18 Bedford Row, Dept. PR, London WC1R 4EJ, England.

BYTE and **BYTE** are registered trademarks of McGraw-Hill, Inc.

smARTWORK[®] Keeps Getting Smarter



Smarter Artwork

Three years ago, Wintek engineers created smARTWORK to reduce the time and tedium of laying out their own printed-circuit boards. Thousands of engineers have since discovered the ease of use and sophistication that makes smARTWORK the most popular PCB CAD software available. And thanks to them, smARTWORK keeps getting better.



smARTWORK transforms your IBM PC into a PCB CAD system

Interactive routing, continual design-rule checking, pad shaving, and production-quality 2X artwork have always been a part of smARTWORK. And now that many customer suggestions have become a part of the software, smARTWORK is an even better value. *That's why we offer it with a thirty-day money-back no-nonsense guarantee.*

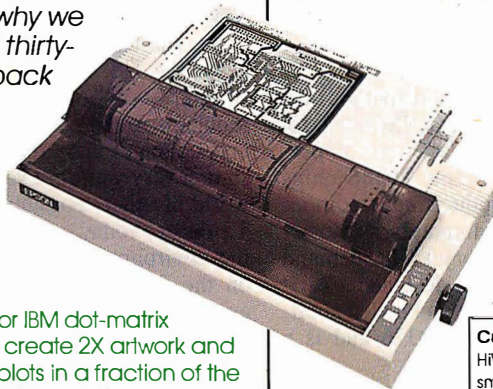

Using an Epson or IBM dot-matrix printer, you can create 2X artwork and 1X or 2X checkplots in a fraction of the time hand-taping requires

New smARTWORK Features

- Silkscreen layer for component placement and identification
- Text capabilities for all three layers
- Selectable trace widths and pad shapes and sizes
- User-definable library
- Ground planes created with a single command
- Solder-mask and padmaster plots generated automatically
- Quick printer 2X checkplots
- Additional drivers for printers and plotters
- Optional drill-tape and Gerber photoplotter utilities
- AutoCAD[®] .DXF file output
- Completely updated manual
- 800 number for free technical assistance

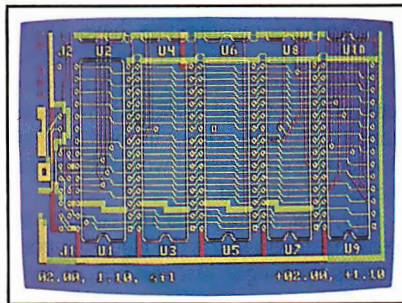

2" by 4" section of a 10" by 16" double-sided board with silkscreen layer

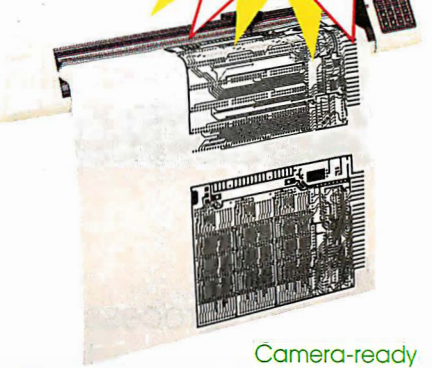

Camera-ready 2X artwork from an HI or HP pen plotter

The Smart Buy. Guaranteed.

Still priced at \$895, smARTWORK is proven, convenient, and fast. Our money-back guarantee lets you try smARTWORK for 30 days at absolutely no risk. Call toll free (800) 742-6809 today and put smARTWORK to work for you tomorrow. That's smart work.

System Requirements

- IBM PC, PC XT, or PC AT with 384K RAM, and DOS V2.0 or later
- IBM Color/Graphics Adapter with RGB color or B&W monitor
- IBM Graphics Printer or Epson FX/MX/RX-series printer, and/or
- Houston Instrument DMP-40, 41, 42, 51, 52, or Hewlett-Packard 7470, 7475, 7550, 7580, 7585, 7586 pen plotter
- Optional Microsoft Mouse

Wintek Corporation
1801 South St.
Lafayette, IN 47904
Telephone: (800) 742-6809
In Indiana: (317) 742-8428
Telex: 70-9079 WINTEK CORP UD



"smARTWORK", "Wintek", and the Wintek logo are registered trademarks of Wintek Corporation. "AutoCAD" is a registered trademark of Autodesk, Inc.

Current Versions	
HiWIRE	V1.1r1
smARTWORK	V1.3r5

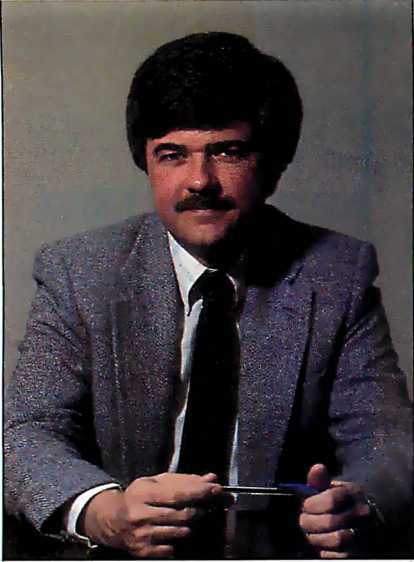

OPEN EVERYTHING

GUIs, grails,
embedded processors,
and one-station radios

We frequently get visitors here at BYTE. People come to demonstrate new products, to find out more about our editorial content and policies, and sometimes just to meet the folks who put out the magazine. It's always a pleasure to talk to the visitors, and it's always good to exchange information and gain insights on what's happening in the industry.

Sometimes, these insights arrive in unexpected ways.

For example, after a tour of our Lab and editorial facilities, one recent visitor was puzzled at the large number of different computing environments he'd seen: SunView, Windows, the Macintosh's Desktop, OS/2's Presentation Manager, Open Look, Next Step, and Open Software Foundation's Motif all were either up and running, or had been running and were now visible as slides and screen shots lying around various offices.

"They all look the same," the visitor said. "It's getting hard to tell them apart."

Indeed. Oh, there are real, substantive differences among these environments. The internal variances are enough to turn a systems programmer prematurely gray. And as for on-screen differences, well, these three interfaces have three-dimensional highlighting of the user-selectable buttons, this one has tear-off menus, that one has virtual pushpins. . . .

But focusing on these differences is equivalent to "looking at the trees," while our visitor was commenting on a forest of remarkably uniform vegetation. From an end user's perspective, the differences among the top-of-the-line graphical user interfaces (GUIs) are

overshadowed by the many similarities.

In some very real ways, today's best GUIs have attained the long-sought grail: They are alike enough to be generally familiar, even at first sight. Most people (certainly most BYTE readers) can sit down and start poking their way around one of these advanced GUIs without a lot of trouble. No, these GUIs aren't perfect, but they've gone a long way toward knocking down the walls separating different machines and operating systems.

This breaking down of walls has profound implications for the hardware and software we'll be using in the future. Even so, it's only part of an even larger trend toward openness. To continue the analogy, just as the walls are breaking down, so are the ceilings.

The old distinctions between workstations and microcomputers have totally vanished. You can't tell the difference anymore between a high-end microcomputer and a low-end workstation because there is no difference, as our 50-page supplement on personal workstations last February indicated.

And, just as the walls and ceilings are breaking down, so are the floors: A computer is no longer just the box on your desk. Computers are also powerful processors invisibly embedded in numerous products, from laser printers to network controllers and beyond. Our fundamental definition of "what is a computer" will soon have to change.

I'm not talking about the glorified digital clock mounted in a Mr. Coffee: Intel says that as recently as last year, 30 percent of all top-of-the-line 80386 chips were installed in products not traditionally thought of as "computers." (Motorola tells a similar story.) The demand was so strong that Intel designed a variant of the 80386 just for embedded applications; it's called the 80376 and is a close cousin to the 80386SX.

So, the walls, the ceilings, and the floors of computing are all vanishing. What's left?

A new openness. In fact, an astonishing openness. Some of it is so blatant that it hits you over the head: Open Token, Open Look, Open View, Open Link, Open Software Foundation, and Open Systems Interconnect; Open this and Open that.

A bit more subtly, there are hardware developments like EISA (Extended Industry Standard Architecture), which will try to keep at least a piece of the 32-bit bus market open; and software developments like the wide acceptance of XWindows, SQL (Structured Query Language), RenderMan, and PostScript and its clones—which, while not fully open, serve somewhat the same purpose by being *lingua francas* of the microcomputing software world.

The trend to extreme openness in official and de facto standards is happening faster and spreading far more widely than most people predicted. And there's no slowdown in sight—standards themselves are starting to merge.

For example, XWindows is gaining three-dimensional graphics by merging with PHIGS—the Programmer's Hierarchical Interactive Graphics System, itself an internationally accepted standard for three-dimensional graphics. This hybrid of the two separate standards will be bundled, along with other extensions to XWindows, in a package called PEX.

So, the trend is crystal clear: Nowadays, the old, easy, one-brand or one-standard solutions to microcomputing problems make about as much sense as one-station radios: You may get that one station very well, but you'll be missing a world of other, possibly better, options. To master today's mixed microcomputing environment, you need information on the full spectrum of possibilities—and that's what BYTE is all about. There's no room for closed minds in today's open environments.

—Fred Langa
Editor in Chief
(BIX name "flanga")

INTERACTIVE WINS THE UNIX TECHNOLOGY RACE!



VP/ix - DOS under

TCP/IP Host - based

NFS

X11.3 Windowing System

UNIX V.3.2

Call today! 1-800-346-7111

INTERACTIVE

A Kodak Company

2401 Colorado Avenue
Santa Monica, CA 90404

Circle 137 on Reader Service Card

Contestant:		
INTERACTIVE 386/ix RELEASE 2.0		
UNIX	✓ Shipping UNIX V.3.2	Qualifying UNIX Technology Events WITH PROPRIETARY ENHANCEMENTS! BINARY COMPATIBILITY FAST FILE SYSTEM, HI-PERFORMANCE DISK DRIVER, AND DIRECT DISK PAGE-IN!! EXPANDED CHARACTER HANDLING SIMPLE! EXPANDED DRIVER SUPPORT
	✓ Runs XENIX Applications	
	✓ Disk Performance Trials	
	✓ International Competition	
	✓ Installation	
GRAPHICS	✓ Standard Graphics Support	386/ix X11 WINDOWING SYSTEM RELEASE 3 WORKS WITH VP/ix TCP/IP AND NFS!
	✓ Graphics Integration	
NETWORKS	✓ Industry and DOD Standards	386/ix TCP/IP INTERLAN, 3COM, WESTERN DIGITAL, UNGERMANN-BASS ETC. 386/ix NFS!! TOPOLOGY INDEPENDENT
	✓ Host or Board Based Protocols	
	✓ Transparent File Sharing	
MS-DOS	✓ Runs DOS Programs	EVEN FLIGHT SIMULATOR®! FILE TRANSFER UTILITIES & MOUNTABLE DOS FILES
	✓ Read/Write/Transfer DOS Files	
	✓ THE CHOICE IS CLEAR!	

UNIX is a registered trademark of AT&T. 386/ix is a trademark of INTERACTIVE Systems Corporation. MS-DOS, XENIX, and Flight Simulator are registered trademarks of Microsoft Corporation.

Copyright 1989 INTERACTIVE Systems Corporation.

DISCOVER COMPLETE

Gateway 2000 set out 4 years ago with one goal in mind. To be the #1 direct we knew that we had to provide "complete customer satisfaction". As we see quality equipment at the best price available anywhere. The customer has addition to this we had to build a reputation for incredible service that was confidently say that we have achieved these goals. Although we are not yet have thoroughly checked out the competition, and suggest that you do the GATEWAY 2000 computer system. And we can guarantee you that we will system. If you won't take our word for it take a look at what our customers chosen by BYTE magazine for their annual BYTE awards. Our 386-20 was Call us toll-free to discover "complete customer satisfaction".

"We are very happy that our system is at the top of the stack in both price and performance, but it is your courteous service that is uncontested by the competition."

— Pierce Haviland — Kingston, NY

"Overall, I feel that your product is outstanding and your service has been excellent."

— Eric Shogren — Stonington, CT



12 Mhz 286 VGA

2 Megs RAM
1.2 Meg 5 1/4" Drive
1.44 Meg 3.5" Drive
40 Meg 28ms SCSI Drive
10 Mbits/Sec DTR
16 Bit VGA Board
14" VGA COLOR Monitor
1 Parallel/2 Serial Ports
101 Key Keyboard
MS DOS 4.01

\$2295.00

16 Mhz \$2395.00

20 Mhz \$2495.00



25 Mhz 386 VGA

4 Megs RAM
1.2 Meg 5 1/4" Drive
1.44 Meg 3.5" Drive
150 Meg 16.5 ms ESDI Drive
10 Mbits/Sec DTR
16 Bit VGA Board
14" VGA COLOR Monitor
1 Parallel/2 Serial Ports
101 Key Keyboard
MS DOS 4.01

\$4495.00

(Call for 33 Mhz Option)

20 Mhz 386 VGA

1 Meg RAM
1.2 Meg 5 1/4" Drive
1.44 Meg 3.5" Drive
80 Meg 28ms SCSI Drive
10 Mbits/Sec DTR
16 Bit VGA Board
14" VGA COLOR Monitor
1 Parallel/2 Serial Ports
101 Key Keyboard
MS DOS 4.01

\$2995.00

(Upgrade to 4 Megs \$500)

All systems have a 30 day Money Back Guarantee and 1 Year Warranty.
Due to the Volatility in the DRAM Market all prices subject to change.

CUSTOMER SATISFACTION

marketer of micro computers in the nation. In order to attain this lofty goal it, to achieve "complete customer satisfaction" we had to supply the best to feel that he or she received most value for their hard earned money. In completely unheard of in the mail-order business. At this point we can the largest company in the market we strongly feel that we are the best. We same. We want you to feel entirely confident of your decision to purchase a do everything in our power to keep you satisfied after you receive your are saying about us. In addition to this we were the only "clone" company chosen out of the hundreds of products they reviewed for it's overall value.

- *"It is a refreshing experience to work with a company that trys very hard to give real service to the little guy."*
John Curran
Simi Valley, CA
- *"It is evident that the level of integrity at Gateway 2000 is high and definitely confidence inspiring."*
Elias Ilyia, Ph.D.
Seattle, WA

1 9 8 8

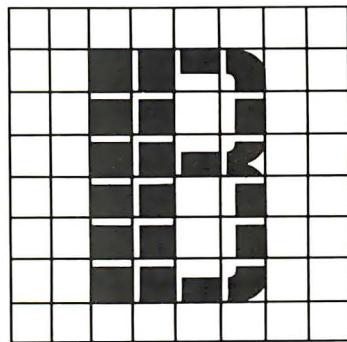

B Y T E

A W A R D O F

D I S T I N C T I O N

Gateway 2000
P. O. Box 2000
Sgt. Bluff, IA 51054
800-233-8472
712-943-2000





Creative License.

If you've ever tried to combine windows, menus, forms, and text entry to create an effective user interface, you know how challenging it can be.

Perhaps you've turned to a third-party library for help. Only to run into restrictions, limitations, and dead ends. So you had to compromise your design. Or modify the library source code. Or start over.

Which is precisely why we designed Vermont Views™, the new generation of Windows for Data®, the best-selling Clibrary for user interfaces.

Vermont Views offers unbridled, unrestricted creative license.

The Human Interface Of Your Dreams

Vermont Views offers an unparalleled set of interface building blocks that you can combine in unlimited ways:

- Menus can be created in any style you choose, made scrollable vertically and horizontally, and nested to any level. Features include n-th character selection, checkmarks, and unavailable items.

- Data entry forms can be bigger than their display windows, have scrollable regions for the entry of variable lines of items, lists of choices for data entry, context sensitive help, and special decimal, date, time, and toggle fields.

- A mini word processor can be attached to a field window in a form or

used as a pop-up note taker.

You're In Charge

Because you can write and attach functions to the beginning and end of menus, forms, fields, and to keys, you're always in control.

Use these control functions to call up subsidiary forms and menus, change field values and the active field, exit or abort a form, do almost any task you can imagine.

All interactive capabilities of Vermont Views use a unique system of accessible keytables, so you can easily change or disable key assignments - even add to the functions provided for menus, forms, text entry, and windows.

One For All

Vermont Views is available for DOS, OS/2, UNIX, XENIX, and VMS. Maintain the same user interface on all of these operating systems with the same source code.

Vermont Views provides international portability as well, with full support for IBM international characters, flexible date and time formats, and changeable decimal and thousands separators.

Novice Or Expert

Despite its depth and flexibility, Vermont Views is easy to learn and use. Each major facility is covered in a single, self-

contained section of the manual, so you only need to learn capabilities as you use them.

To help you become an expert in no time, we include a free copy of the Norton Guides™ Engine and our own comprehensive Pop-Up Reference™. You'll have immediate, on-line access to function names, reference pages, structures and tables.

No-Time-Limit Guarantee

We've only touched on a fraction of what makes Vermont Views special. The only way to know it is to use it.

Try Vermont Views on your hardest problems.

For as long as you want. At no risk.

If not fully satisfied, return for a full refund. Anytime.

To Order Today Call 1-800-848-1248

Call to order Vermont Views today. And we'll send your "creative license" right away.

Prices: DOS \$395; with Source \$790. UNIX, XENIX, VMS, OS/2 please call.



Vermont
Creative
Software

Pinnacle Meadows, Richford, VT 05476

800-848-1248, 802-848-7731 Fax: 802-848-3502 Telex: 510-601-4160 VCSOFT

MICROBYTES

Staff-written highlights of developments in technology and the microcomputer industry, compiled from Microbytes Daily and BYTEweek reports

Intel's New 80860 CPU Aims to Be a Cray on a Chip

Amid all the speculation over Intel's forthcoming 80486 chip were rumors that it was powerful enough to become the heart of a minicomputer or even a future mainframe. Now it looks as though the subject of those rumors wasn't the 80486 after all, but another new Intel CPU—one that's designed to be a microprocessor version of a Cray supercomputer.

The new 80860 (or i860) came out from under wraps at the end of February, but engineers at the IEEE International Solid-State Circuits Conference in New York got a sneak preview two weeks before the official debut. Code-named "N-10" while under development, the 80860 is a 64-bit RISC CPU containing one million transistors and running at up to 50 MHz.

Most current RISC processors use several chips; SPARC CPUs, for example, use five different chips, and Motorola's 88000 consists of a three-chip set, including instruction and data caches. But the 80860 has them all on a single chip. One-third of the CPU consists of the data and instruction caches; another third handles integer instructions; and a final third comprises the floating-point adder and multiplier units. Intel says the on-chip caches allow a data transfer rate of nearly 1 gigabyte per

second, far faster than is possible with external cache chips. And the three separate FPUs can work in parallel, meaning as many as 120 million operations per second at 40 MHz.

Still more interesting, according to members of the 80860 design team, is the fact that the FPUs are modeled after Cray's pipelined vector architecture. When a series of identical floating-point operations is performed on a collection of data, the chip doesn't have to wait for the first calculation to finish before beginning work on the second calculation. The FPUs are designed to work in stages, so they perform each part of a lengthy floating-point operation separately and then send the result down the pipeline to the next stage. (The separate adder and multiplier can even be configured to automatically send the results of one FPU to the other for more processing.) That translates into extraordinarily fast vector processing. Intel claims that the 80860 runs at better than 85,000 Dhrystones per second, which would be about twice as fast as the next quickest RISC chip available (one company's 33-MHz version of Sun's SPARC chip has been clocked at 40,000 Dhrystones per second).

The chip also includes three-dimensional graphics

hardware for Gouraud and Phong shading. It's as a graphics coprocessor that Intel will initially market the chip, and the company expects to see it appearing by late this year on add-in boards for graphics workstations.

Fabrication on the 80860 is 1-micron static CMOS, which means you can stop the clock without losing anything. Intel already has FORTRAN-77 and C compilers for the chip, and Unix version 4 is supposed to be ready by the end of the year. When we spoke with Intel right before press time, the company was quoting quantity prices of \$750 for end-of-the-year delivery.

Does the introduction of the 80860 mean that Intel is abandoning the world of 80x86 processors? Hardly. The 80486 is scheduled to be out by the end of this year, and Intel officials believe that the IBM PC-compatible line still has plenty of life in it. The 80860's future may be as part of a supermini-computer, with multiple 80860 CPUs running Unix; such a machine could show up sometime next year. But that doesn't mean the new chip couldn't show up in personal computers, as well; an 80860 and 8 megabytes of RAM would easily fit on an IBM PC AT-style plug-in card. Cray-in-a-box, anyone?

NANOBYTES

- **Mach Three:** Unix software house **Mt Xinu** (Berkeley, CA) plans to develop versions of Carnegie-Mellon University's **Mach multiprocessing operating system** for three workstation environments: **Sun-3, DEC VAX, and IBM RT PC**. Mt Xinu says its versions will be binary-compatible with Berkeley Unix 4.3, will adhere to "standard interfaces such as Posix, and will also incorporate Carnegie-Mellon's Andrew software and MIT's X Window system." Releases are slated to start early next year, the company says.

Mach acquired some commercial glamour last October when Steve Jobs introduced the NeXT computer, which incorporates the Mach kernel. (For more on Mach, see the November 1988 BYTE cover story on the NeXT system.)

- The jaded ones who said they saw nothing new at the recent **MacWorld Expo** in San Francisco must have missed the **WristMac**, a Seiko-built digital watch that **connects directly to a Mac serial port via a special cable** for uploading or downloading information.

The watch holds up to 80 two-line displays of 12 characters each, which you can edit on either the Mac or the watch. Push a button, and the WristMac will cycle through up to a dozen files you've

continued

New "Mainstream" Mac II: Three NuBus Slots, Less Filling

Last month, Apple Computer introduced yet another member of its growing family of Macintosh II systems, a model that CEO

John Sculley described as the "mainstream" machine of the Macintosh II "modular product line." This one, called the Macintosh IICx (at

least that's how Sculley referred to it when Apple gave us an early look), features three NuBus expansion slots

continued

NANOBYTES

created. Each file can contain up to 79 entries. Files can be timed alarms that display a message, names or phone numbers, or any other text the user enters or downloads. It's \$225 for the standard black WristMac. A \$295 "executive version" comes with a water-resistant metal case, gold buttons, and a one-piece metal wristband; it's glitzy, but no one will mistake it for a Rolex. From Ex Machina, of New York City.

• **Hitachi Ltd.** of Japan has developed a **semiconductor laser** that acts as a light source for "very high-speed optical communications systems." The laser has a proprietary new structure that comprises an "organic insulating film embedded in the semiconductor element," a spokesperson said in an interview with Microbytes Daily.

The semiconductor laser operates on a single line spectrum that allows it to transmit 16 gigabits of information per second over long distances "without wave-form distortion," the spokesperson said. The laser is seen as a key component in the development of a high-speed optical transmission system to link geographically distributed computers. The new semiconductor also has its place in the ongoing development of video phones and high-definition TV (HDTV) image transmission systems.

• **Microtec Research** (Santa Clara, CA) has a new **high-level debugger for the Zilog Z80 processor**. The

continued

instead of the six slots available in the Mac II and Mac IIX. The Mac IICx has the same 16-MHz Motorola 68030 processor as the Mac IIX; and we found no difference in performance between it and the Mac IIX. However, the new system comes in a smaller box—the footprint is about 12 by 15 inches. Although it's more compact, the Mac IICx's logic board has the same circuitry as the Mac IIX, including the 256K-byte single in-line memory module ROM and the Floppy Disk High Density internal floppy disk drive controller, which can read and write MS-DOS, OS/2, and Apple II 3½-inch floppy disks.

The newest Mac features a modular design reminiscent of the IBM PS/2 series. The cover, power supply, and drive housings have snap fittings made of high-

strength plastic, so you can disassemble the entire machine in a few minutes. The machine has a quiet 90-watt power supply (in contrast to the 220-W power supply of the Mac II and IIX) and two 3½-inch bays for a floppy disk drive and a hard disk drive (the Mac II and IIX have 5¼-inch bays that can also be used for 3½-inch drives). Other changes include an external DB-19 serial port for connecting an external floppy disk drive and an auto-restart capability so that the machine automatically reboots in the event of a power outage.

At press time, Apple had not yet specified prices or configuration options for the Mac IICx. However, Sculley said the Mac IICx would cost roughly the same as the Mac IIX (basic unit, \$6969; with an 80-megabyte hard disk drive, \$7869).

Sculley said it's roughly an equal trade-off to swap three slots and a small box for the six slots and larger footprint of the Mac IIX.

Apple also brought out a new 15-inch portrait-oriented gray-scale monitor with 640- by 870-pixel resolution, and a 21-inch gray-scale monitor offering 1152- by 870-pixel resolution. Both come with a Mac II video card that can be configured with either 2-bit or 4-bit pixel depth (allowing display of 4 or 16 shades of gray, respectively).

Apple also announced a 160-megabyte 5¼-inch hard disk drive (Model 160SC) for the Mac II and IIX. The 160SC does not fit into the new Mac IICx's hard disk bay.

We'll have more details and photographs of the newest Mac in the May issue of BYTE.

"Location Transparency" Next Hurdle for Database Technology

They don't care where it is; they just want to get there. Database users say their biggest concern is access to data—data scattered across several computers that don't talk to each other. A few computer companies are firing up their efforts to make access an easy, invisible process. Most of these companies are focusing on the mainframe level, but many of the techniques they develop will wind up on microcomputers within the next few years. IBM, for example, is working on the concept of "location transparency" for its DB2 relational database system, says Jnan Dash, manager of Data Systems Strategy at IBM.

Location transparency would mean that an end user could access data without knowing where the data resides on the database network, which could include machines running AIX,

OS/2, and IBM's mainframe VM operating system. An engineer at an airplane manufacturer working on an AIX-based CAD workstation, for example, would be able to transparently call up some data from an IBM 370-based mainframe running VM.

The basis for location transparency is the idea of the distributed database, which is finally starting to become a real technology. The client/server model is "old hat," according to DEC product architecture manager Barry Rubinson. Rubinson says "inter-operation" in a "mixed vendor shop" will become the standard environment in the next few years and that database vendors will have to provide the tools that allow their products to transparently access data stored under other vendors' database products. The key, he

says, will be the standardization of Structured Query Language. The current chaos in SQL standards will change in the next few years, he says. "Right now, SQL usually means you have a SELECT statement in your database language." However, Rubinson predicts that a standard for SQL will emerge by 1991.

Performance is the least concern of database software buyers, according to vendors, corporate planners, and consultants at the recent DB/Expo in San Francisco. What buyers are most concerned with is the ability to work transparently with diverse and remote systems and to have a data typing scheme that is fluid enough to handle complex objects like airplane diagrams, digitized photos, and recorded speech.

"Mixed environments

continued

You'll never know how quick it is until you open it up and see what it can do.

All the horsepower in the world is useless until you can get at it.

Introducing new Microsoft® QuickC® version 2.0. The fastest, easiest way to master all the power and glory of C. Frankly nobody but Microsoft packs this many exclusive features into a single package:

For starters, there's QC Advisor — a new hypertext electronic manual that teaches, helps and guides you *on screen*. It even lets you cut and paste sample programs, so you can learn C the easy way.

By example.

And "C For Yourself," our detailed book of C fundamentals that'll give you more in-depth programming lessons. You'll find one in every box.

With Microsoft QuickC, you can ease into C with Easy Menus to help you write your first C programs, then advance to Full Menus to access the full-throttle potential of C. You'll be up to speed in no time.

And speaking of speed, QuickC has enough muscle for incremental compiling and linking at an incredible 25,000 lines per minute—so it'll make short work of any development you have in mind.

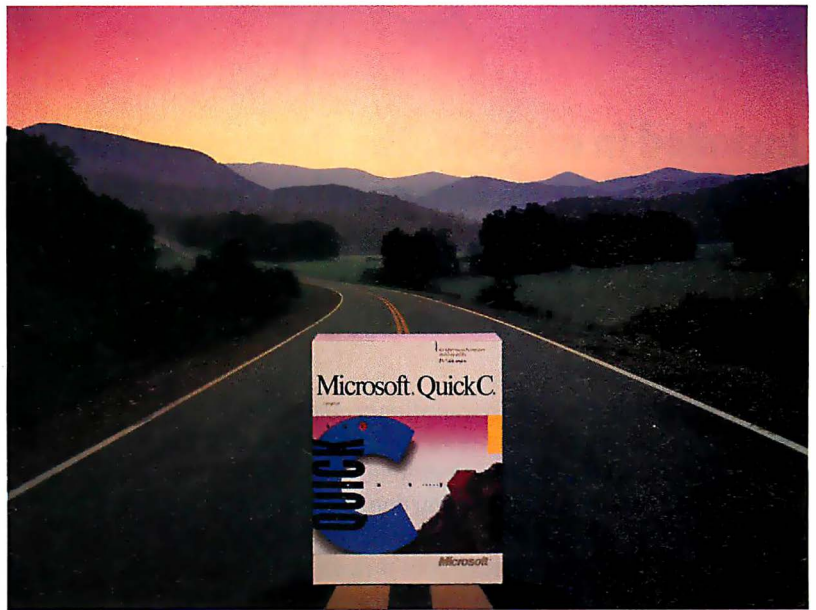

New Microsoft QuickC 2.0. Zero to expert in record time.

And speaking of development, its in-line assembler lets you write assembly code within your C code for more efficient programs. Plus it's the only integrated debugger that lets you simultaneously debug C *and* your in-line assembler. Talk about convenience. It even supports all memory models within the integrated environment.

For all the details, call us at (800) 541-1261. The new Microsoft QuickC.

Get it. And break a few speed limits.

Microsoft
Making it all make sense.

REPLACE YO



PC WORLD
"Upgrade products of the year."
...PC World

"Editors' choice"
...PC Magazine



Installed in minutes, the Renegade 386™ motherboard turns any IBM PC, XT, AT or inexpensive clone into a powerful new computer, lightning fast with both old software AND new OS/2 releases.

Is this you? You would like to have extraordinary computing speed and power. You want number crunching ability. You need complex CAD capabilities. Or graphics. Or multi-tasking. And you haven't got it. (And you don't want to spend a fortune to replace good equipment with the newest standard.) Weep no more. You can turn your *present* system into the latest, high-performance system that will *equal or exceed the best of the new computers.*

Renegade 386™ A new heart and brain for your computer.

Renegade Technologies offers designers, engineers, architects, and computer-dependent businesses a simple and reliable alternative to obsolescence. Or the unreasonable expense of a new system.

Simply replace the "motherboard" of your present system with a Renegade 386™ motherboard.

It takes a screwdriver and less than 20 minutes. And costs but \$1695.

That's *thousands of dollars less* than a new IBM System/2 Model 80.

But it gives you more than just the latest industry standard. You can run your old software on it. Probably anything you now use on your XT or AT. Big Blue can't do that.

You can use your present 16-bit peripherals. (If you've looked at PC "add-on" cards, you already know your old equipment would be useless.)

But with Renegade 386™ you'll have to find some other excuse to throw away your current modem, network card,

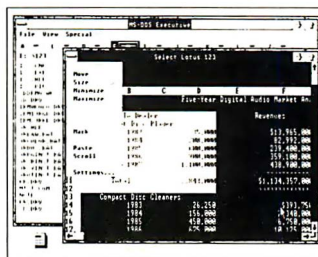

Multi-task with Lotus 1-2-3 and other applications running side-by-side on the Microsoft Windows/386 desktop.

EGA or disk controller cards. The Renegade 386™ board comes with an iron-clad *one year limited warranty.* It uses genuine U.S. made Intel 386 chips and is designed and manufactured in the U.S.A.

by Hauppauge Computer Works. Hauppauge is a major developer of software support for Microsoft and IBM products, and is producer of the highly respected Hauppauge 8087 or 80287 highspeed math coprocessors. Over 50,000 have been sold. Major computer magazine reviews in the last year have hailed our Hauppauge-made board as a major breakthrough in a high speed, high power, high performance upgrade product.

Not an accelerator card. Not a "turbo" gimmick. Renegade 386™ gives you a full-featured new computer.

Thanks to Renegade's 80386 microprocessor your computer will now boast a 32-bit data path—and a clock speed of 16 MHz with zero wait state access. Up to 8 expansion slots are provided depending on your computer configuration.

Your "new" computer also will now have 1 Megabyte of 100ns RAM. This is *not* a naked board. And it also includes a 32-bit high-speed RAM expansion slot which you can populate with up to 15 Mbytes of system memory.

UR MOTHER

In practical terms that simply means that programs like Lotus 1-2-3 or new products like Foxbase 386, and almost anything else, *will run faster than anything you have ever seen.*

Which is a minor problem for some folks who are playing computer games on company time. Renegade 386™ may run them at speeds far too fast for human reactions.

The world is not perfect.

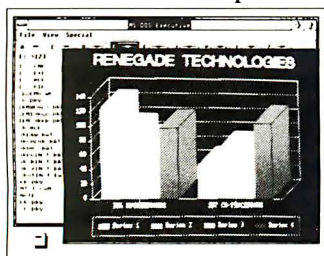

Faster, easier presentation graphics with newest software releases.

Otherwise Renegade 386™ is perfectly compatible with products like AutoCAD, Aldus PageMaker, Microsoft Windows, Ventura Publisher, the Novell Network and sizzlers like Paradox 386. We haven't yet found a popular program we can't run with it.

Power hungry? Equip Renegade 386™ with even more RAM—without speed loss.

Add up to 15 Mbytes of system memory with Renegade™ expansion modules that plug right into your Renegade 386™ 32-bit expansion slot. *And run with no loss of speed*—something no IBM or Compaq model can match.

There's a lot of confusion in computer claims, but the fact is that with *zero* wait state, our 16 MHz is effectively the same as those highly touted machines running at 20 MHz with one wait state.

So plug in Renegade™ expansion modules in 2- and 4-Megabyte increments and run Windows 386 applications at the speed God intended.

386 MotherBoard for the PC or PC/XT	\$1695
386 MotherBoard for the PC/AT	\$1795
386 MotherBoard/20 MHz for PC/AT	\$2195
32-bit RAM Board (2Mbyte installed; up to 10 Mbytes)		\$1195
16 MHz 80387 math coprocessor	\$695
16-bit combination hard disk/floppy disk controller		\$245

Prices subject to change.

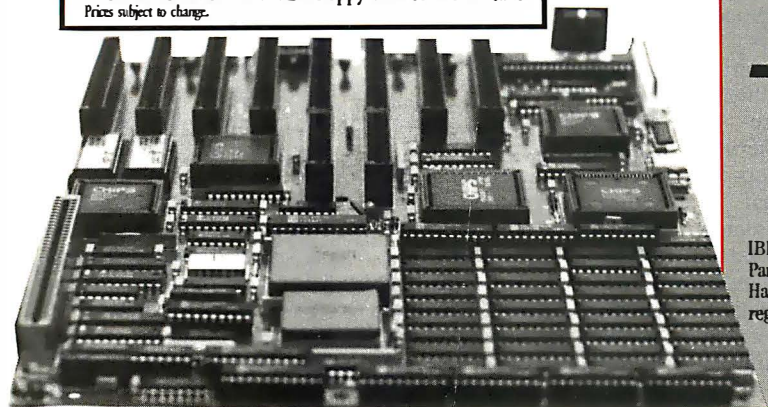

30 DAY TRIAL OFFER AND OUR NO-RISK GUARANTEE

We understand perfectly that you have no reason to believe anything you read. Including this ad. (We read too.)

So we invite you to evaluate the Renegade 386™ yourself. Call and order one. We'll send it with detailed, clear instructions. Use it in your own system, on your own work, for 30 days. Try it for brilliant presentation graphics, make massive and instant spreadsheet recalculation, run huge memory-hungry CAD programs. Wring it out—on anything your software is up to.

But don't stop there. Challenge your best computer technician. Or a consultant whose opinion you value. Ask them to compare Renegade 386™ dollar for dollar, and feature for feature, with the best on the market.

After 30 days, if it isn't for you, for *any* reason, we'll take it back and write you a check immediately for your full purchase price.

The risk is all ours. But we urge you not to wait. RAM chip prices are going up every day due to worldwide chip shortages. We can guarantee this current price only if you order now.

Call toll-free today. You have nothing to lose but yesterday's computer system.

1-800-426-2189

Renegade

TECHNOLOGIES

Redmond, Washington USA

(206) 885-5700

IBM PC, AT, XT, Personal System/2, Microsoft Windows 386, Foxbase 386, Paradox 386, PageMaker, 1-2-3, Novell Network, Ventura Publisher, EGA, Intel, Hauppauge, Compaq and other brands and products are trademarks or registered trademarks of their respective holders.

NANOBYTES

XRAYZ80 package includes a compiler, an assembler, a software simulator, and a debugger. In addition to the vendor's own simulator package, the debugger supports in-circuit emulators from Hewlett-Packard, Applied Microsystems, and ZAX. The IBM PC version starts at \$3500; the solo debugger starts at \$1750.

- **NEC** (Tokyo) plans to start offering samples of a **33-MHz μ PD70632 MPU** this fall and a **40-MHz** model next year. A 45-MHz version has been tested, and the company hopes to develop 50- and 60-MHz versions next.

- **Guides to Words and Street Corners: Highlighted Data** (Washington, DC) has put out two of the more **helpful CD-ROM products** we've seen yet. The first is a **version of Webster's Ninth New Collegiate Dictionary**, which not only includes all the text and diagrams in the hard-copy version, but **also talks**. The disk contains recorded pronunciations of each word in the dictionary. The second CD-ROM can generate almost any street map of the U.S., the vendor says. The company claims that the **Electronic Map Cabinet** disk includes every street corner in the country. Both disks cost \$200.

- **Farallon Computing** (Berkeley, CA) plans to extend its reach into high-speed Ethernet systems, company officials say. Due for a midyear release, Farallon's **EtherTalk** is an implementation of Ethernet protocols for AppleTalk networks. Like Local-

continued

are the real environments," says Martin Sprinzer of Relational Technology. "We must get to data no matter where it resides," and this process should be transparent to the user. For corporate database users, that means transparent no matter what the location, data format, operating system, or user interface.

Distributed databases and gateways are seen as part of the answer. But as database guru C. J. Date puts it, there are some very difficult problems associated with distributed systems. To maintain data integrity in a distributed system, for instance, various data replication schemes have evolved. All of them require a trade-off, said Date, between data protection (during retrievals or updates) and performance. An emerging technique called *snapshots* essentially takes a "picture of

the database" that can be used in read-only mode while other users can continue using the database. Snapshots might be promising, Date says, because they offer "some of the functionality of replication but without some of the headaches."

Another important advance we heard forecast at DB/Expo involves extensions to the relational database model, which will allow for object-oriented data, such as a document data type or a drawing or image data type. Experts at the conference also said I/O performance of transaction processing is speeding up considerably, approaching 2.5 I/O cycles per transaction (the rate has traditionally been 10 to 20 I/O cycles per transaction, according to Rubinson). Relational Technology redid the architecture on its DBMS this past year, says Sprinzer, and the

company will be releasing products over the next two years that will let users "write an application once on VMS and then access it transparently on Unix." Oracle's Ken Jacobs said his company wants to "make GUIs [graphical user interfaces] invisible. We're working very hard to make a product look like Presentation Manager, the Mac interface, or Open Look." Expect announcements "very soon," he said, that point toward the "integration of data dictionaries and computer-aided software engineering tools into one thing."

Most vendors and consultants agree that the database environment isn't all that mixed at the top. IBM has the mainframe world sewn up with DB2. "Anybody who'd compete against DB2 is nuts," said one panelist at DB/Expo.

Superconductivity Still a Cool Proposition

Superconductor research in the past year has advanced incrementally, but researchers have made no major breakthroughs, according to the evidence at the second annual International Superconductor Applications Convention, held recently in San Francisco.

Although one young company called Magnetic Power, Inc. (Sebastopol, CA), claimed to have developed a bismuth thin film with superconducting properties at room temperature, the claim has not been verified or reproduced in other laboratories. Another researcher, Dr. Brian Ahern of the Rome Air Development Center at Hanscom Air Force Base in Massachusetts, claimed to be close to verifying room-temperature superconductivity using titanium boride. However, the evidence was still preliminary and has not been

reproduced.

Conference keynote speaker Dr. Simon Foner, chief scientist at the Francis Bitter National Magnet Laboratory, warned against the "overhype" of the media regarding superconductivity breakthroughs and called for more "truth in advertising." Foner said that high-temperature (77° Kelvin) superconductive materials still are not practical for most commercial applications. But Foner also cautioned against the pessimistic fears that the U.S. "will lose to Japan" in the race to produce commercial superconductivity applications.

Most of the research presented at the conference is still focused on a transition temperature range of 4° to 120° Kelvin. The transition temperature is the maximum at which the material exhibits the superconducting properties of virtually zero re-

sistance and high magnetic shielding. Both U.S. and Japanese researchers are working on developing new materials and production methods for superconductivity applications.

A major problem involves increasing the thermal and structural stability of very thin films used in superconductivity applications. Because of the sensitivity to temperature and the large energy density required in superconductive materials, thermal stability and high yield strength are crucial properties. Some of the research going on at companies like General Electric and IBM involves developing high-strength substrates, such as graphite, on which the superconducting film is mounted.

According to some sources, financiers are keeping a cool eye on the super-

continued

BRIDGES

With Sysgen Bridge-Files,
data *can* get there from here.



Toshiba® T3100 with NEW Bridge-Laptop™ 5.25/T. Work on 5.25" diskettes with your Toshiba laptops (T3100 and up). Dual capacities of 360Kb and unique 1.2Mb capacity—*more* than available from Toshiba!



Compaq® Deskpro™ with Bridge-File 3.5. Lets all popular PC compatibles access 3.5" PS/2 and laptop files. Dual 720Kb and 1.44Mb capacities.

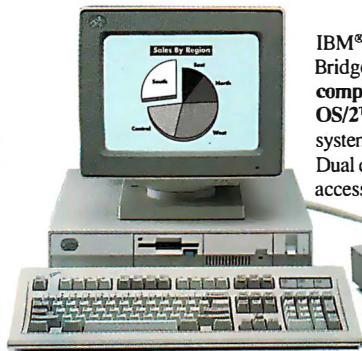
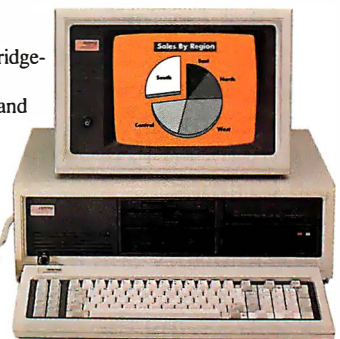

IBM® PS/2™ Model 30 286 with Bridge-File™ 5.25. Now compatible with DOS 4.0 and OS/2™. Give ALL your 3.5" systems easy access to 5.25" disks. Dual capacity 360 Kb/1.2 Mb access to all files.



IBM PC/AT™ with Bridge-File 3.5. With Bridge-File any IBM PC/XT™ or AT generation computer can be upgraded to share information with your newer systems.

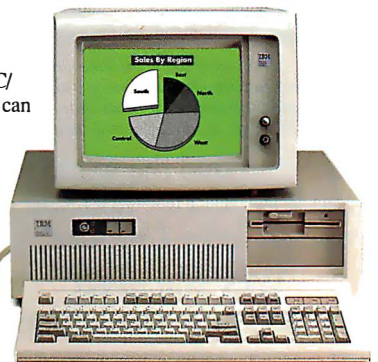

The problem.

Your PCs, PS/2s, Toshiba laptops and PC compatibles may share the same office. But still be worlds apart.

Different floppy disk sizes and formats can yield isolated information *islands* instead of productive work *groups*.

The Solution: Bridge-File 5.25 and Bridge-File 3.5 drives.

The only complete bridge family in the industry, Bridge-Files *can* get your data from here to there. And vice-versa. Your different computers will be working with common diskettes in no time flat.

Bridge-File 5.25 gets rave reviews for

its small footprint, ease of use and dual capacities. With over 100,000 at work for satisfied users, it's a proven best-seller. Now your PS/2s, Toshiba laptops and other 3.5" systems can access your PC files.

Bridge-File 3.5 lets your 5.25" PCs access files from other, 3.5" systems. And Bridge-File 3.5 functions as *either* an external or internal drive. Make all your current information accessible to all your computers.

Omni-Bridge™ Controller.

Control up to *four* 5.25", 3.5" and floppy tape drives in any combina-



tion. Omni-Bridge makes XT/AT upgrades easy — you get access to all your data, twice the transfer speed and increased storage. And it's economical — at \$95, Omni-Bridge is too good to pass up.

For literature or the Bridge-File dealer nearest you, call:
1-800-821-2151

SYSGEN

INCORPORATED

Sysgen Incorporated, 556 Gibraltar Drive, Milpitas, CA 95035.
©Copyright Sysgen, Inc. 1989. All trademarks above are the property of their respective holders.

Now Peter Norton

If you've ever seen the words "GENERAL FAILURE ERROR" on the screen of your PC, you know you don't need to be ill to feel sick.

All you need is a corrupted disk with some valuable data stored aboard.

When that happens, it's time to call on the remarkable new *Norton Disk Doctor*™.

The Norton Disk Doctor is one of 27 data recovery and disk management tools in the latest Advanced Edition of the Norton Utilities®.

It's also the most significant advance in utility software technology since Peter Norton first began saving the data and the derrières of grateful PC

C> FILE NOT FOUND!

Our legendary UnErase—and its short-cutting offspring Quick UnErase have saved the derrières of thousands of grateful PC users. And they're still saving them.

users around the world with the legendary—and still unequalled—*UnErase*®.

Why you need a Doctor in the house.

Now, whenever INVALID DRIVE SPECIFICATION or some other cryptic or catastrophic error message appears on your screen, you can do something besides reach for the Maalox®.

You can summon the Disk Doctor, which will

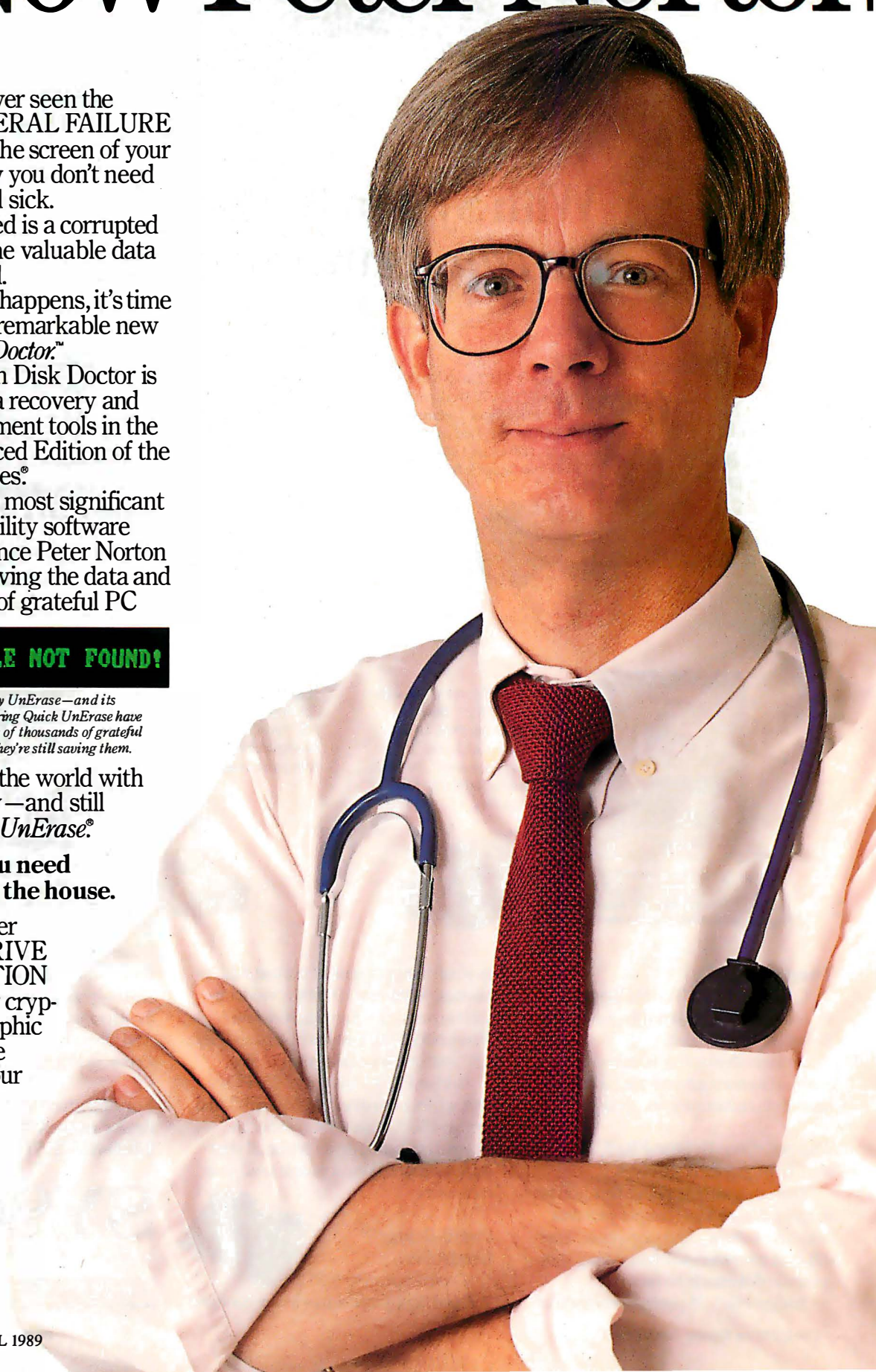

makes house calls.



determine the exact nature of the problem, report it and, in most cases, fix it for you.

All by itself.

The Disk Doctor can diagnose and repair everything from bad partition tables and boot records to mangled root directories. It can even reformat bad sectors and write back the old data.

Automatically.

In fact, if the Doctor can't cure your corrupted floppy or hard disk, then Buster, you've got one corrupt disk.

In which case, you'll need to refer to *The Norton Troubleshooter*, a 158-page guide to finding and fixing most anything that could go wrong.

Don't worry, you don't have to go to the bookstore or the library to refer to it, because the Troubleshooter is included in the Advanced Edition.

Frankly, the Norton Disk Doctor and the Norton Troubleshooter are worth the price of the new Advanced Edition all by themselves.

But, of course, they aren't by themselves.

They're accompanied by a wish list of features, functions and enhancements sufficient to satisfy the yearnings of all those people who've been politely writing and calling to request them.

The people's choices.

Like *Speed Disk*, the world's most powerful disk tuning tool, which features four user-selectable optimization methods and doesn't lose your data if you lose power.

And *Format Recover*, which can unformat your accidentally reformatted hard disk even if you haven't taken any precautions beforehand.

Our user interface, which *InfoWorld* said made the Utilities "as easy to use as possible," now comes with pop-up windows and dialog boxes.

Our new *Norton Control Center*™ lets you define or alter a range of system settings—from cursor size to screen and palette colors—quickly and easily.

While our *Disk Test* finds and marks faulty areas on your disk to help you protect your data before you have a chance to lose it.

If you want to lose it, however, you'll be glad to know that *WipeFile*™ and

WipeDisk™ support DoD 5220.22-M 116b(2), the Pentagon's latest data security specification.

Which means they'll erase your files so thoroughly not even Peter Norton can find them.

You'll find the latest Norton Utilities at your

favorite software dealer.

If you haven't got a favorite software dealer, take two aspirin, call us right away at 1-800-365-1010 and place an order.

The Doctor will be on its way in no time.

Peter Norton
COMPUTING

All Utilities now support large hard disks under DOS 4.0, COMPAQ DOS 3.31, and the PC-MOS/386 multi-tasking operating system. Designed for the IBM®/PS/2 and PC families and 100% compatibles. ©1988 Peter Norton Computing, Inc. 100 Wilshire Blvd., 9th Floor, Santa Monica, CA 90401-1104

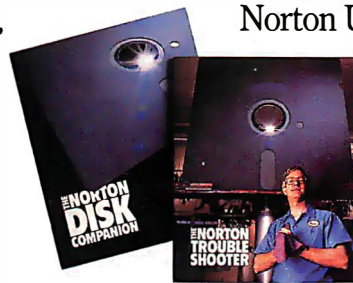

The Norton Disk Companion is included, free, with both the Standard and Advanced Editions. The Norton Troubleshooter is yours with the Advanced Edition.

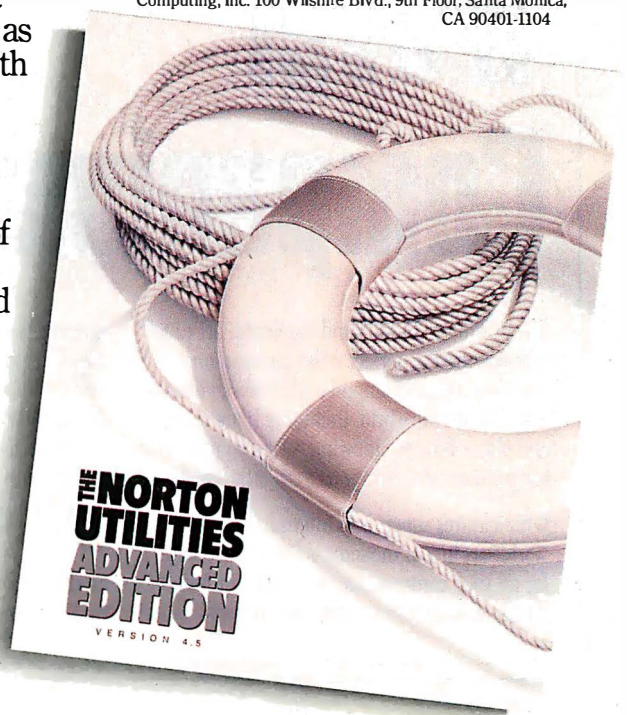

THE NORTON UTILITIES
ADVANCED EDITION
VERSION 4.5

NANOBYTES

Talk, EtherTalk will use the twisted-pair wiring of telephone lines. Farallon plans to provide all the "in-building plumbing" for EtherTalk, said company president Reese Jones, including connectors that attach to a standard Ethernet AUI port ("all IEEE 802.3 devices") and a StarController to build and control topology. PhoneNET with EtherTalk will run about \$1000 per machine, Jones said.

• **Publishing with Iris:** Full Color Computing (Danbury, CT) now has versions of its **Full Color Publisher** desktop-publishing-and-more program for Silicon Graphics's three-dimensional

continued

conductor industry. Although the government and some venture capitalists are willing to take the risk of funding something so abstract, many would-be backers think

commercial development is too far away. In a survey by Coopers & Lybrand's High Technology Industries Group in Boston, 60 percent of the capitalists questioned

said an adequate return on investment would not be possible in the 10-year span of a limited partnership; 29 percent said the technological risk is too high.

CEBus Chip Provides Brains for Jetsonesque Smarthome

You're on the couch, watching television. The turkey is done roasting, so, using your TV remote control, you shut off the oven. Then you realize how cold it is inside the house, so, using the same remote control, you close the curtains and turn up the thermostat. Then it's back to Big Time Wrestling.

That's part of the promise of "home automation" as promoted by the Electronic Industries Association. The EIA wants the backbone of Jetsonesque abodes to be the

Consumer Electronic Bus (CEBus), proposed as a standard by which home appliances can communicate with each other. Some heavyweights of home electronics demonstrated this LAN for dishwashers, VCRs, microwave ovens, and entertainment systems at the Winter Consumer Electronics Show in Las Vegas.

The CEBus "Smarthome" exhibit at CES featured 17 appliances, including a Sony television, an RCA VCR, and a Johnson Controls thermostat (those com-

panies are all EIA members). At the heart, or brain, of the demonstration was AISI Research's "Spirit" technology, the first implementation of the CEBus architecture in a silicon chip.

CEBus is a set of specifications for encoding and transmitting information over almost any medium, including twisted-pair wires, coaxial cable, infrared signals, radio waves, and fiber optics. But the focus of AISI and the EIA is to use a house's existing AC power

continued

Travel Companions.

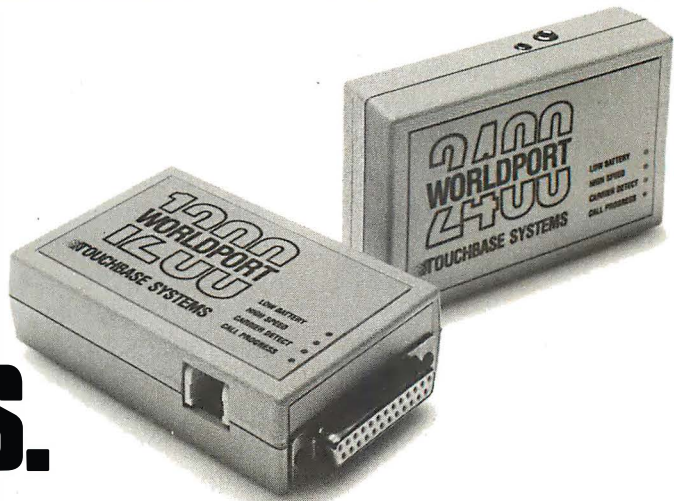

The WorldPort 2400™ and the WorldPort 1200™ modems are the perfect travel companions for your portable computer. They work virtually anywhere in the world, including hotel rooms and phone booths, allowing you to connect in a few million more locations than other modems.

With features superior to internal units, the WorldPort line of modems is the smart choice for all your communication needs. WorldPort modems operate from their own internal battery,

drawing no power from your laptop. Cutting edge technology brings you features such as Bell and CCITT standards, direct connect and acoustic interface (300 and 1200 bps), tiny size and a tiny price. The WorldPort 1200™ can be easily upgraded to 2400 bps and both the WorldPort 2400™ and the upgrade come with Carbon Copy PLUS™ communications software.

Find out more about the travel companions that won't tie down your portable computer. Call us

today for more information about the WorldPort line of modems, or the name of your nearest dealer, at **800-541-0345**. (In New York, 516-261-0423.)



Touchbase Systems, Inc.
160 Laurel Avenue
Northport, NY 11768
(516) 261-0423
TELEX: 6502848020
FAX: (516) 754-3491

WorldPort 1200 and WorldPort 2400 are trademarks of Touchbase Systems, Inc.. Carbon Copy PLUS is a trademark of Meridian Technology Inc.

Take
**Software Development
Library** for only **\$4.95!**

Please accept my application for trial membership and send me Software Development Library (00975) billing me only \$495, plus shipping and handling. I agree to purchase at least three additional Selections or Alternates over the next 12 months. Savings range up to 30% and occasionally even more. My membership is cancelable any time after I buy these three additional books. A shipping and handling charge is added to all shipments.

No-Risk Guarantee: If I am not satisfied—for any reason—I may return Software Development Library within 10 days. My membership will be canceled, and I will owe nothing.

Name _____

Name of Firm _____
(If you want subscription sent to your office)

Address _____ Apt. _____

City _____

State _____ Zip _____

(Books purchased for professional purposes may be a tax-deductible expense. Offer good in Continental U.S. and Canada only. Prices slightly higher in Canada.)

Call 1-800-888-4843 to join now!

Byte 4/89

7-FF8

Take
**Software Development
Library** for only **\$4.95!**

Please accept my application for trial membership and send me Software Development Library (00975) billing me only \$495, plus shipping and handling. I agree to purchase at least three additional Selections or Alternates over the next 12 months. Savings range up to 30% and occasionally even more. My membership is cancelable any time after I buy these three additional books. A shipping and handling charge is added to all shipments.

No-Risk Guarantee: If I am not satisfied—for any reason—I may return Software Development Library within 10 days. My membership will be canceled, and I will owe nothing.

Name _____

Name of Firm _____
(If you want subscription sent to your office)

Address _____ Apt. _____

City _____

State _____ Zip _____

(Books purchased for professional purposes may be a tax-deductible expense. Offer good in Continental U.S. and Canada only. Prices slightly higher in Canada.)

Call 1-800-888-4843 to join now!

Byte 4/89

7-FF8

**10-Day
Free Examination**



BUSINESS REPLY MAIL

FIRST CLASS PERMIT NO. 230 RIVERSIDE, NJ

POSTAGE WILL BE PAID BY ADDRESSEE

NO POSTAGE
NECESSARY
IF MAILED
IN THE
UNITED STATES



**The Library of Computer
and Information Sciences**

Riverside, New Jersey 08075-9889



**10-Day
Free Examination**



BUSINESS REPLY MAIL

FIRST CLASS PERMIT NO. 230 RIVERSIDE, NJ

POSTAGE WILL BE PAID BY ADDRESSEE

NO POSTAGE
NECESSARY
IF MAILED
IN THE
UNITED STATES



**The Library of Computer
and Information Sciences**

Riverside, New Jersey 08075-9889



Take the 3-volume Software Development Library for only \$4.95

as your introduction to the
Library of Computer and
Information Sciences

You simply agree to buy 3 more books—at
handsome discounts—within the next
12 months.

- Create more reliable software using object-oriented techniques
- Design effective screen interfaces between the programs and the users
- Deliver a completed software project, even under the most unreasonable time constraints
- Save \$106.00 on this extraordinary 3-volume set

Object-Oriented Software Construction

Bertrand Meyer

Hundreds of invaluable examples of reusable software components and full case-study descriptions that show you techniques to streamline and improve virtually any large software development project. Uses the object-oriented language Eiffel.

Publisher's price: \$42.00.

Handbook of Screen Format Design

Third Edition
Wilbert O. Galitz

This insightful guide shares with you specific guidelines for designing data entry, inquiry, multipurpose, interactive, and menu screens. Covers monochromatic and color alphanumeric terminals as well as graphics terminals.

Publisher's price: \$39.95.

Crunch Mode

Building Effective Systems on a
Tight Schedule
John Boddie

Cut specification time in half, sidestep time-consuming methodologies, and keep your development team from self-destructing with this invaluable collection of time-saving tips, techniques, and short-cuts for coping with "impossible deadline" projects.

Publisher's price: \$29.00.

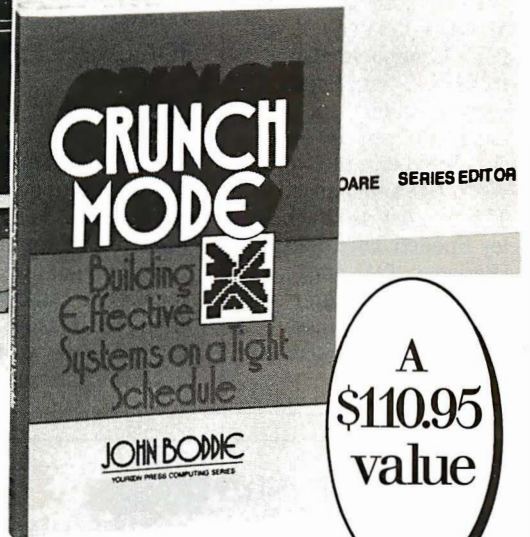
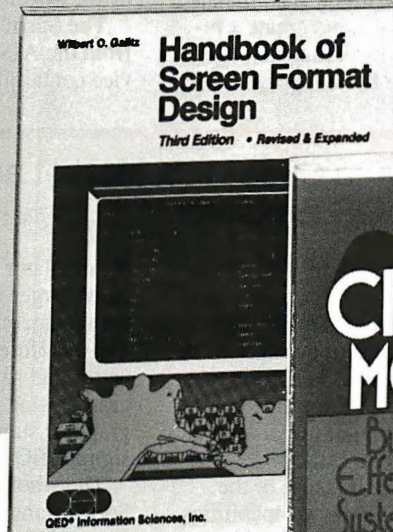
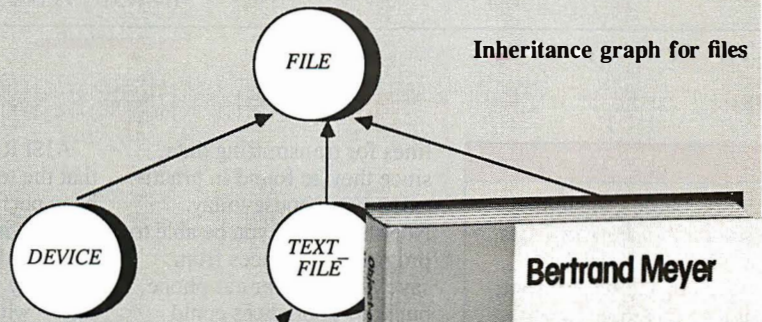

A
\$110.95
value

MEMBERSHIP BENEFITS • In addition to getting the Software Development Library for only \$4.95 when you join, you keep saving substantially on the books you buy. • Also, you will immediately become eligible to participate in our Bonus Book Plan, with savings of 65% off the publishers' prices. • At 3-4 week intervals (16 times per year), you will receive the Library of Computer and Information Sciences News, describing the coming Main Selection and Alternate Selections, together with a dated reply card. • If you want the Main Selection, do nothing, and it will be sent to you automatically. • If you prefer another selection, or no book at all, simply indicate your choice on the card and return it by the date specified. • You will have at least 10 days to decide. If, because of late mail delivery of the News, you should receive a book you do not want, we guarantee return postage.

© 1989 Macmillan Book Clubs Inc.

The Library of Computer and Information Sciences is the oldest, largest book club especially designed for computer professionals. In the incredibly fast-moving world of data processing, where up-to-the-moment knowledge is essential, we make it easy to keep totally informed on all areas of the information sciences. What's more, our selections offer you discounts of up to 30% or more off publishers' prices.

If reply card is missing, please write to The Library of Computer and Information Sciences, Dept. 7-FF8-00975, Riverside, NJ, 08075, for membership information and an application.
BYTE 4/89 **Call 1-800-888-4843 to order now!**

NANOBYTES

workstations, including the mighty Personal Iris. Full Color Publisher goes beyond page layout; it also has tools for painting, retouching photos, and manipulating images. The package that runs on SG's Personal Iris sells for \$8995.

• **How do you pronounce "loquiter"?** The Franklin Language Master-4000 can tell you. It's a hand-held electronic talking dictionary capable of speaking 83,000 words. You simply type in the word you'd like pronounced. The product, by Berkeley Speech Technology (Berkeley, CA) and Franklin Computer (Mt. Holly, NJ), uses

continued

lines for transmitting data, since they're found in practically every house today. Not only would you be able to program appliances from, say, your cellular car phone, but your appliances could also communicate with each other. With CEBus, manufacturers could create a remote control that handles any number of appliances.

AISI Research admits that the technology hasn't been perfected. Most home power wiring isn't designed to carry data, so there's a tendency for home systems to have "white noise"—background interference caused by the system.

The Spirit chip evolved from the AISI "brick," a device containing a micro-

processor coupled with analog circuitry to provide full implementation of CEBus. The Spirit chip incorporates all the functions of the much larger brick, while improving performance and signal quality, according to AISI Research. The company, based in Vancouver, BC, is marketing the chips for about \$5.

Insignia Sees Unix Market as Biggest Opportunity for DOS Emulator

Although Insignia Solutions introduced a new version of its SoftPC MS-DOS emulation program for the Mac II at January's MacWorld Expo, the company's bigger target market for SoftPC is the Unix environment. Because of the virtual memory capabilities of Unix-based machines,

the emulator can access a much larger memory space than it can on the Macintosh, and therefore it can perform better and run MS-DOS programs using EGA and VGA graphics standards, says Insignia CEO Nick Samuel.

The whole trick to the SoftPC emulation technology is translating the MS-DOS

Intel-based instruction to a set of instructions executable by the host machine's processor, which can be a Motorola, as in the case of the Mac, or other RISC processors supported on various Unix platforms. However, the translation is not one-for-one. On the Macin-

continued

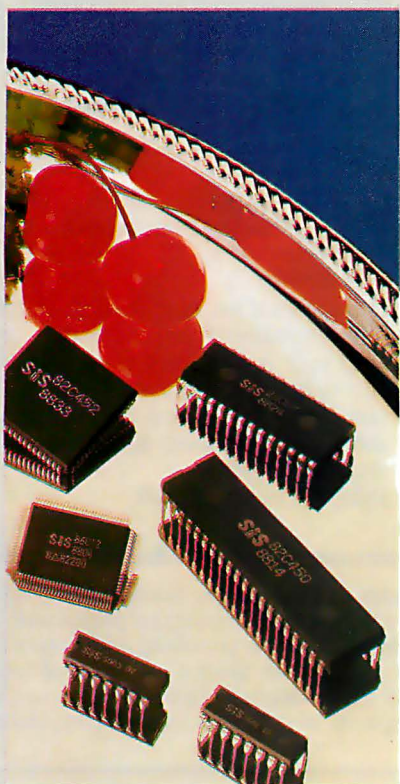

**Food For Thought!
Distributors Welcome!**

- Computer IC
 - 82C11
 - 16C452
 - 16C450
 - 83C747*
 - MGA/CGA/HCGA
 - Character ROM
 - Memory IC
 - 32K/64K/128K/256K
 - 512K/1M/2M*/4M*
 - CMOS MASK ROM
 - Consumer IC
 - Speech
 - Melody
- ◆ * ◆ Under-Development



11F, No. 56, Sec. 4, Nan-King E. Rd.
Taipei, Taiwan, R.O.C.
TEL: 886-2-7765770 FAX: 886-2-7773109

UNDERSTANDING DESKTOP MAPPING

Recent developments by MapInfo in linking graphics with traditional database information results in new ways to visualize data

Rarely has a new software technology burst into the marketplace with the excitement and high potential of desktop mapping. More than 100 specific applications for desktop mapping technology have already emerged, and current estimates suggest that over 80 percent of PC users could make immediate use of this new tool.

Desktop mapping has little to do with the making of maps — the job of cartographers. Rather, it involves the use of maps to get more meaning and knowledge out of databases — particularly if they have some type of locational field, such as a street name and number, city, ZIP code, county or state.

A lot of software products out there are putting themselves (or are being put) into the desktop mapping category, which runs the spectrum of functionality, ease of use, and price.

One product—MapInfo, from MapInfo Corp.—has emerged in the past year, offering the performance and capabilities of high

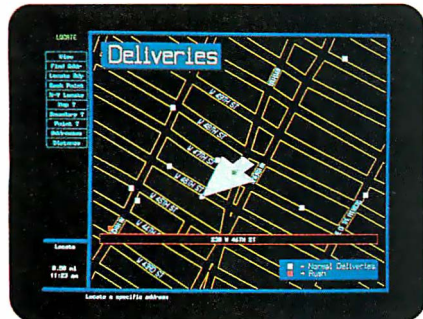

Find Addresses MapInfo Corp.'s street maps come with every address already in place, accurate to the correct block and side of street. Simply type an address and MapInfo locates it for you. Or, automatically plot existing data on the map for "what-if" analyses.

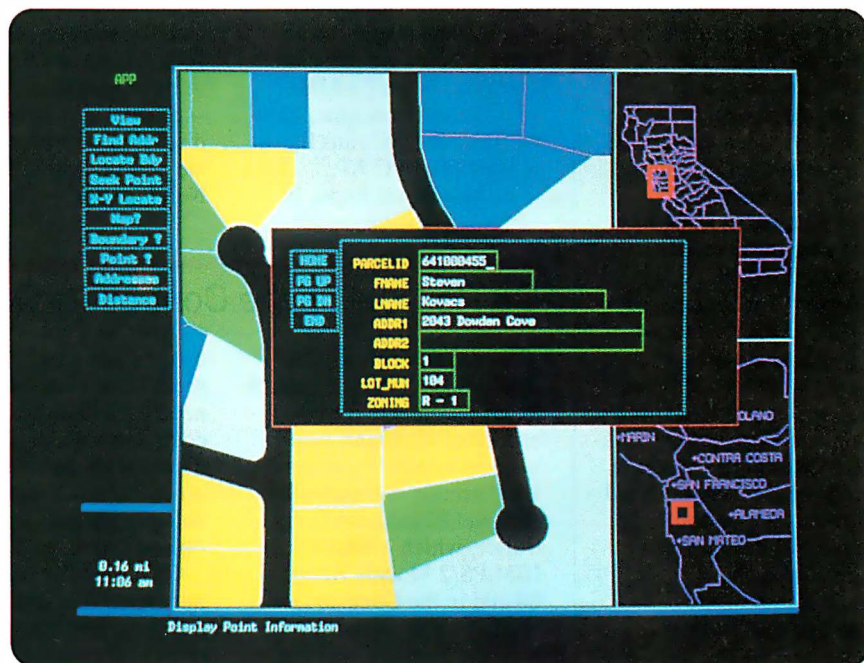

Database Information Merged With Maps MapInfo's desktop mapping package is the only software designed to directly tie dBASE files with maps. The parcels shown here were automatically shaded based on the data about each. A window is displayed that reveals the actual data behind a particular parcel.

end packages at a price and ease of use that competes with the low end.

On the low end, there are products that sell for \$350 to \$1000 and which are just specialized graphics programs. These programs allow you to take a map, such as one of the United States, decide what colors each state should be, and then overlay text for titles, legends, and captions. However, they cannot interact directly with your database, and do not have the intelligence to find specific addresses at the street map level.

On the high end, there are expensive software products that are typically called Geographic Information Systems (GIS). These products will let you combine your databases with maps in an interactive fashion. Even when converted for use on a PC, however, they are still expensive, starting at \$5,000 for the software alone.

But for \$750 you can buy the powerful MapInfo engine, which reads your dBASE files and lets them interact with an incredible range of computer maps. The maps, including street maps for most metropolitan areas, county maps, state maps, and so forth, are available separately from MapInfo Corp.

Already, thousands of people across the nation are using MapInfo to gain more knowledge from their databases. Synthes Corp. is using MapInfo to do new market research in Paoli, PA. The Syracuse, NY police department is using MapInfo to visually compile crime statistics. And, in San

"One product—MapInfo, from MapInfo Corp.—has emerged in the past year, offering the performance and capabilities of high end packages at a price and ease of use that competes with the low end."

Francisco, MapInfo is being used to compare locations of AIDS cases with educational outreach efforts.

MapInfo Corp. has established a special toll free hot line to answer your questions about this exciting new technology. For more information, call 1-800-FASTMAP or 518-274-8673, or write to them at 200 Broadway, Troy, NY 12180.

NANOBYTES

Berkeley's Bestspeech text-to-speech (T-T-S) conversion technology, which previously has been available only at high prices for personal computers and mainframes. Speech quality and pronunciation accuracy are on par with Berkeley Speech Technology's most expensive speech-to-text systems, the company claims. The Franklin Language Master-4000 retails for about \$300. Berkeley Speech Technology has also licensed Bestspeech T-T-S to Hewlett-Packard and Personal Data Systems. Possible future applications, besides talking dictionaries, include talking translators, word processors, and talking toys with mega-vocabularies.

- ROMmed DOS: **Award Software** (Los Gatos, CA) has started shipping a ROMmed version of **Digital Research's DR DOS**, an MS-DOS 3.3-compatible operating system. The **Award ROS** is available in a "hard" version on four 64K-byte chips (on a \$250 plug-in board) or as modules of object code that can be licensed to system developers. Developers can pick from modules that perform parts of DOS and then burn those modules into ROM chips to be installed on the system baseboard. For diskless workstations and smart terminals, Award claims ROS will allow faster, more intelligent, and more flexible designs. "With key parts of the OS at the workstation, you don't have to go back to the server to get every command," said Award president Rene Vishney.

tosh, for example, SoftPC executes from 8 to 10 native Motorola 68000 instructions for every DOS instruction. This ratio determines the performance of the DOS emulation. On a 68020, DOS programs running under SoftPC perform approximately equivalently to an Intel 8088-based personal computer. On a 33-MHz 68030-based machine, Samuel said, SoftPC runs like a 6-MHz IBM PC AT.

At MacWorld Expo, In-

signia had SoftPC with EGA support running on Intergraph workstations with the Fairchild Clipper processor. A version without EGA support is available on HP 68000-based workstations. Insignia plans to have this high-performance version running soon on other Unix systems and on DEC VAX minicomputers.

Samuel says Insignia has discussed with NeXT a possible port of SoftPC to the NeXT computer. But he said

it is "premature" to talk about these discussions. It requires a major investment to port SoftPC to a new hardware platform—in the "high six figures," he said.

Insignia Solutions also has a SoftPC version ready for Apple's A/UX version of Unix, but, according to Samuel, there has been very little demand for it.

Contact: Insignia Solutions, 787 Lucerne Dr., Sunnyvale, CA 94086, (408) 522-7600.

C&T's New Cache Controllers Compete with Intel's

Chips & Technologies' new set of cache controller chips suitable for 20- and 25-MHz 80386-based systems is entering a market currently dominated by the Intel 82385 cache controller, which is used in the IBM PS/2 Models 70 and 80 and in the Compaq Deskpro 386. The company hopes to compete with the Intel device by offering a unique design that integrates memory and cache control

on the same chip. This integrated chip eliminates the need for a discrete DRAM controller, which is required with the Intel chip, according to Chips & Technologies product manager Nelson Chan.

Chan said the company's integrated design also minimizes cache "misses" and thus makes possible better performance than the Intel 82385. Chips & Technologies claims that its cache

controllers (called the 82C307 and the 82C327) will result in OEM system cost savings of up to \$94 in comparison to the cost of implementing the Intel cache controller design.

Possible customers for the Chips cache controllers include Zenith, Tandy, Texas Instruments, and Dell Computer, though none of these companies have officially confirmed that they will use the controllers.

Graphics Hardware Designers Like Mac SE/30's Slot

Although the Mac SE/30's 030 Direct Slot is incompatible with the NuBus and the standard Macintosh SE expansion slot, designers of graphics equipment are very pleased with it. Why? The 030 slot offers faster video performance than the NuBus, since there's no need to worry about bus arbitration or synchronizing with the 10-

MHz clock speed of the NuBus. In interviews with *Microbytes Daily* at MacWorld Expo, designers agreed that the 030 Direct Slot is a nice piece of engineering.

SuperMac quickly introduced its Spectrum/8 Series II card right after the official debut of the SE/30. This 8-bit color display card supports displays of up to 1024

by 896 pixels with 256 colors. Its Virtual Desktop feature lets you work with a larger desktop than the actual size of the monitor. (The actual size depends on the graphics mode; in black and white, the Virtual Desktop is 4096 by 1792 pixels.)

E-Machines has introduced a 21-inch monochrome display for the Mac SE/30. The Big Picture Z21 SE/30 has a two-million-pixel video memory and can support screen sizes up to 2048 by 1024 pixels.

RasterOps doesn't have anything for the Mac SE/30 yet, but vice president David Smith says it will offer all its color boards and a version of its new accelerator board on the Mac SE/30.

TECHNOLOGY NEWS WANTED. *The news staff at BYTE is interested in hearing about new technological and scientific developments that might have an impact on microcomputers and the people who use them. If you know of advances or projects relevant to microcomputing, please contact the Microbytes staff at (603) 924-9281, send mail on BIX to Microbytes, or write to us at One Phoenix Mill Lane, Peterborough, NH 03458. An electronic version of Microbytes, which offers a wider variety of computer-related news on a daily basis, is available on BIX.*

SEE THE FULL SPECTRUM

SOTA VGA/16 Delivers It.

SOTA Technology — a pioneer in accelerator board technology — now brings high-speed, high-resolution graphics to your PC.

SOTA VGA/16 is designed to optimize the performance of all popular software. Its industry leading 16-bit memory and BIOS interface, is designed to take advantage of the extra performance offered by 286/386 machines. In fact, speed increases of up to 400% faster than the IBM VGA are realized.

In addition to being faster, SOTAVGA/16 also gives you more colors and resolution than IBM VGA. Base configuration includes 256 K of video memory, enough memory for 800 × 600 resolution with 16 colors. Plus, it's upgradeable to 512 K — simply plug in the extra memory chips. With 512 K you get 1024 × 768 resolution in 16 colors or 800 × 600 in 256 colors. Software drivers are included for all your popular programs.

The SOTA VGA/16 is 100% VGA hardware compatible and runs current programs such as Windows 386 and OS/2 flawlessly. It is also hardware compatible down to register level with all pre-VGA standards such as EGA, CGA, MDA and Hercules. This means that virtually all existing software will run with the SOTA VGA/16 — and it insures compatibility with future software.

SOTAVGA/16 has two output connectors for full analog and digital monitor support — not just analog, as some manufacturers offer. And, since many of today's programs require a mouse, SOTA built this option right on the board. No longer do you have to compromise an extra slot or sacrifice one of your COM ports to install a mouse. Simply plug it into SOTAVGA/16.

So whether you want to add pizzazz to your business presentation graphics or view your spreadsheet in 132 columns, SOTAVGA/16 is the right choice.

After all, everything looks better in VGA.

For more information on the SOTA VGA/16 please call 800-237-1713. In CA 408-245-3366.

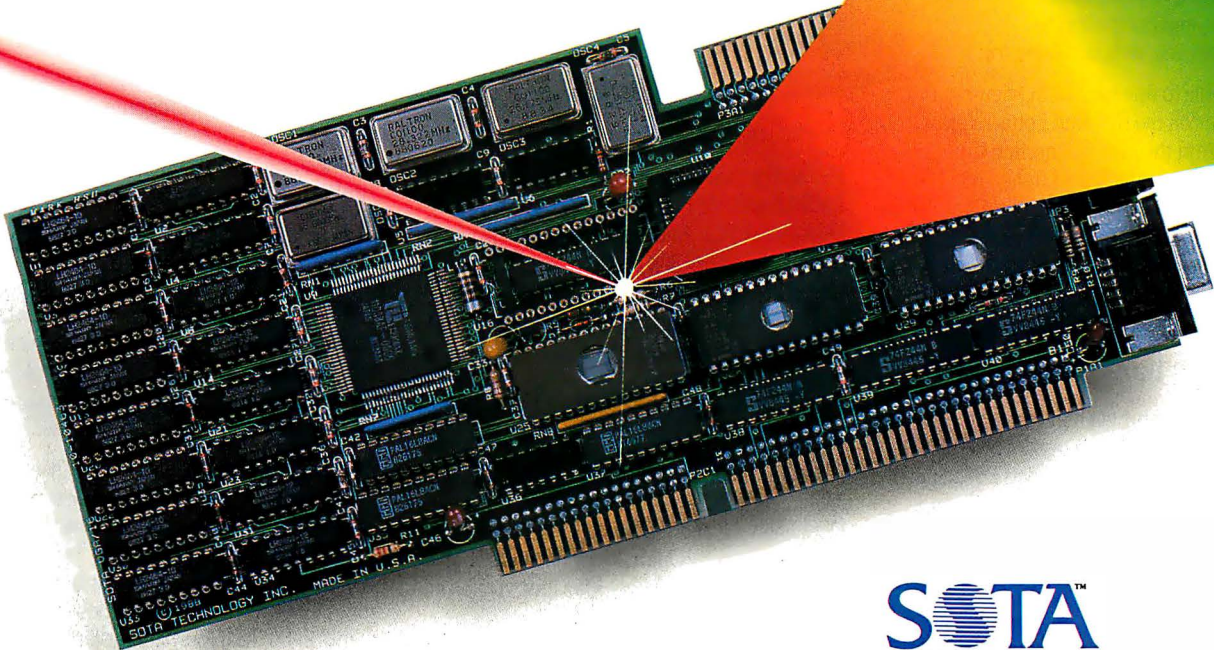

SOTA[™]
STATE OF THE ART TECHNOLOGY[™]

SOTA Technology, Inc.
657 N. Pastoria Ave.
Sunnyvale, CA 94086

SOTAVGA/16 is a trademark of SOTA Technology.
All other products mentioned are trademarks of their respective manufacturers.

Quarterdeck

DESQview 2.2 and DESQview 386. The multitasking, windowing environments that work with your favorite software.

DESQview™ is the operating environment that brings OS/2™ power to DOS. And it lets you, with your trusty 8088, 8086, 80286, or 80386 PC, leap into the next generation in PC productivity. For not much money. And without throwing away your favorite software.

Introducing DESQview 2.2

And now, DESQview 2.2 adds capabilities, performance, and compatibility enhancements you've been asking for:

Like being able to fine tune DESQview performance "on the fly." Run Lotus Express and Metro. And the Intel Connection Co Processor. Even use the DOS 4.0 shell with DESQview. Have DESQview automatically install Quattro, Sprint, Aldus PageMaker, Microsoft Excel, Word Perfect, Dataease and as many as 80 other programs. And using the DESQview API, be able to dynamically link them.

More bang; less bytes

While other programs get bigger, we've worked to make DESQview smaller. And we've succeeded in a big way on PCs and PS/2's with extended, EMS 3.2 (AboveBoard), EEMS and EMS 4.0 memory—as well as on 386 PCs and



DESQview lets you run your favorite programs in windows side-by-side.

PS/2s. For example, DESQview overhead on EMS 4.0 and 386 PCs can be as low as 10K on EGA/VGA PCs. And DESQview actually increases memory 30K on CGA PCs; 20K on monochrome and Hercules PCs. That's good news for users of big desktop publishing, CAD and database programs.

Introducing DESQview 386

For users of 80386 PCs and PS/2s (or PCs with 80386 add-in boards, such as the Intel Inboard 386), there's DESQview 386 (a combination of DESQview 2.2 and the new QEMM-386

Quarterdeck Expanded Memory Manager, version 4.2).

DESQview 386 gives you extraordinary power. Run text, CGA, EGA, VGA, and Hercules programs in

windows and in the background. Run 32-bit 386 programs, like Paradox 386, and IBM Interleaf simultaneously with your favorite DOS programs. All with the speed and performance you expect out of your 386. And with protection against 'misbehaved' programs.

Promise and performance

And, of course, both DESQviews have all the features that made prior versions the popular choice in operating environments. The ability to multitask in 640K and beyond. View programs in windows or full screen. Transfer data. Access DOS via menus. Dial your phone. And create key-stroke macros within and between programs.

Our story gets better and better

If there's any doubt about our commitment to your PC and PS/2 productivity, just look at our accomplishments over the years. We think you will understand why GE, Ford, Aetna, Monsanto, and so many other major corporations use DESQview.

And why PC Magazine gave DESQview its Editor's Choice Award for "The Best Alternative to OS/2," why readers of InfoWorld twice voted DESQview "Product of the Year," why, by popular vote at Comdex Fall for two years in a row, DESQview was chosen "Best PC Environment" in PC Tech Journal's Systems Builder Contest.

DESQview lets you have it all now.



Quarterdeck Delivers.

QEMM. Break the 640K barrier for \$59.95

Your 80386 PC, IBM Personal System/2 Model 80, PC or AT with 80386 add-in board, as well as your IBM Personal System/2 Models 50 or 60 can all break through the DOS 640K barrier. Now you can have maximum use of your memory—whether you have one megabyte or 32—with the Quarterdeck Expanded Memory Manager. All without having to purchase special expanded memory boards.

QEMM uses hidden features within your existing memory to make it compatible with the Lotus-Intel-Microsoft Expanded Memory Specification (EMS) version 4.0.

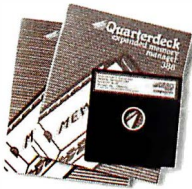

Now you can run colossal spreadsheets, databases, and CAD models designed for expanded memory, using Lotus 1-2-3, Symphony, Framework, Paradox, AutoCAD, Excel and more.

And if you'd like to use these programs all together—multitasking beyond 640K—QEMM works with our popular DESQview multitasking environment.

If you are one of the 12 million or so 8088, 8086 or 80286 PC users who feel left out, don't despair. We have options that let you keep your computer and favorite programs and give you today what the newest PCs and operating systems are promising for the future.

Visit your dealer for more information on barrier-breaking Quarterdeck products.

DESQview API Toolkit. New C and Pascal Libraries, Debugger, Panel Designer. And more.

**DESQview API
Conference '89**
Coming in August
Write for details

API Reference Manual

The key to the power of the DESQview API, our Reference Manual contains all you need to know to write Assembly Language programs that take full advantage of DESQview's capabilities. And there's an 'include' file with symbols and macros to aid you in development.

API C Library

Here are C language interfaces for the entire set of API functions. It supports the Lattice™ C, Metaware™ C, Microsoft® C, and Turbo C compilers for all memory models. Included with the C Library package is the API Reference Manual and source code for the library.

API Pascal Library **NEW!**

The Pascal library provides interfaces for the entire set of API functions. It supports Turbo Pascal V4.0 and V5.0 compilers. Included are the API Reference Manual, source code for the library, and example programs.

API Debugger

The DESQview API Debugger is an interactive tool enabling the API programmer to trace and single step through API calls from several concurrently running DESQview-specific programs. Trace information is reported sym-

bolically along with the program counter, registers, and stack at the time of the call. Trace conditions can be specified so that only calls of interest are reported.

API Panel Designer

This interactive tool helps you design windows, menus, help screens, error messages, and forms. It includes an editor that lets you construct an image of your panel using simple commands to enter, edit, copy, and move text, as well as draw lines and boxes. You can then define the characteristics of the window that will contain the panel, such as its position, size, and title. Finally, you can specify the locations and types of fields in the panel.

The Panel Designer automatically generates all the DESQview API data streams necessary to display and take input from your panel. These data streams may be grouped into panel libraries and stored on disk or as part of your program.

More Tools are Coming

Quarterdeck is committed to adding tools as needed by our users. To that end we have been working with Ashton Tate and Buzzwords International on dBASE III and dBASEIV translators. And in the works, we have BASIC and DOS Extender libraries.

Quarterdeck

Quarterdeck Office Systems, 150 Pico Blvd., Santa Monica, CA 90405 (213) 392-9851
FAX: (213) 399-3802

For additional information, please use the following Reader Service numbers: DESQview: # 234 QEMM: # 235 API Tools: # 236 API Conference: # 237

Just Because You Change Your Mind...

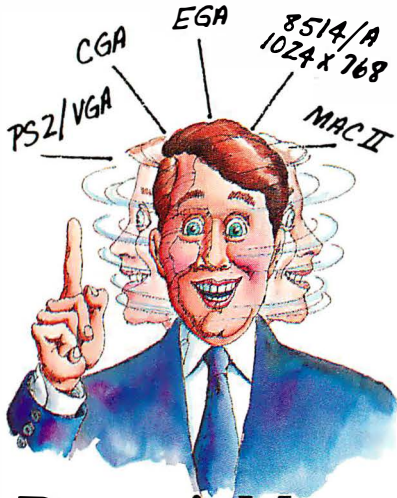

Doesn't Mean You Change Your Monitor.



Auto-Sync by Microvitec. 20" Big. \$2395 Small.

Big differences in graphics standards aren't big problems for you because Auto-Sync adjusts automatically to a large number of graphics cards. Its 20" (19" V) color display gives your graphics the big treatment they deserve. And Auto-Sync's quality is backed by the most comprehensive service plan in the industry. Auto-Sync lets you change your mind in a big way so call Microvitec and change for the better.



1943 Providence Court, College Park, GA 30337
404-991-2246

All trademarks gratefully acknowledged.

LETTERS

and Ask *BYTE*

PC Power

Congratulations on the much-needed article "PC Power" Parts 1 and 2 by Mark Waller (October and November 1988). There is altogether too much misinformation being cast about by those who pretend to know. Specifications that may sound impressive in a peddling contest often have little to do with the real issues. The problem is confounded by oft-quoted mavens and other self-proclaimed pundits who still speak from the "landmark" studies of the seventies that have long since been determined to be invalid. Some seem to think, however, that it is enough just to know studies were done.

Waller describes many of the shortcomings of surge suppressors and ferro-resonant transformers with respect to the needs of modern electronic loads. All I would add to his already good comments is that not only are these approaches not as good as alternatives, but they are actually harmful when misapplied. This point could have been made stronger, I think. All in all, though, Waller's article should go a long way toward broadening the respect for the subject, if not the understanding.

Having said all that, there are two technical points that should be corrected or clarified. In Part 1 on page 280, under the heading "A Better Solution," the text reads, "... a couple of capacitors and a MOV across the secondary..." In actuality, the clamping circuit (MOV or otherwise) belongs on the primary side of the transformer.

A second point concerns Waller's suggestion in Part 2 of a marriage between a

true power-line conditioner and a stand-by power system. This is fine. But the recommendation to put the transformer-based power conditioner on the output of an SPS needs to include one important caveat—you shouldn't drive a transformer with a square wave, or even a pseudosquare wave.

AC power is a very complex phenomenon. But, like music, it has been made so readily available that nearly everyone takes it for granted.

David Fencl
Oneac Corp.
Libertyville, IL

I do not agree that the MOV and filter must be on the primary side of the transformer. Although Oneac puts them there, other manufacturers put them on the secondary side. I'm not sure it makes much difference except that the components tend to be protected by the transformer if they are on the secondary side.

I did not raise the issue of reliability because establishing it from one product to the next is extremely difficult, and I thought a discussion of it was beyond the scope of the article. Implicitly we all want the most reliable product. I'm not sure I understand if you are referring to components, design, or one manufacturer against another.

I do not agree with you that "you shouldn't drive a transformer with a square wave, or even a pseudosquare wave." I know of no compelling reason for this except that if the filter elements are on the primary side of the transformer, they might heat up and fail handling the noise and harmonics from the wave shape, remembering that this occurs only when utility power fails. This further implies that the personal computer can handle this better than a transformer. Again, I don't agree. The whole point of the article was to urge people to buy products with a clean sine wave output so that these concerns are eliminated. The isolation transformer should always be the last line of defense—the closer to the computer, the better.—Mark Waller

continued

WE WANT TO HEAR FROM YOU. Please double-space your letter on one side of the page and include your name and address. We can print listings and tables along with a letter if they are short and legible. Address correspondence to Letters Editor, *BYTE*, One Phoenix Mill Lane, Peterborough, NH 03458.

Because of space limitations, we reserve the right to edit letters. Generally, it takes four months from the time we receive a letter until we publish it.

Who Says FoxBASE+ is Better than dBASE®?

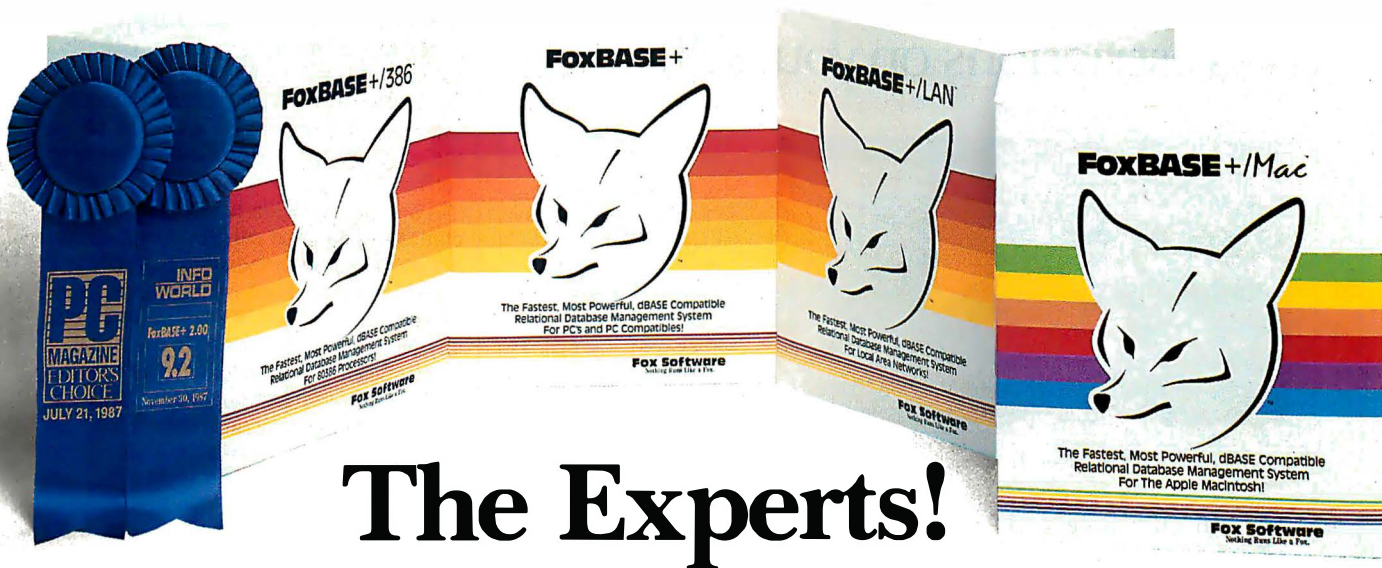

The Experts!

The Best Just Got Better—Now Shipping New FoxBASE+ Version 2.10!

Nicholas Petreley, *InfoWorld* Review Board:

"FoxBASE+ has outdone itself. Once again, FoxBASE+ earns an "excellent" in performance, with kudos for responding to user suggestions. For sheer productivity, there is no other choice." *InfoWorld* "Editor's Choice" for 1987 and 1988!

P.L. Olympia, *Founder & President, National Dbase Users Group / Government Computer News*:

"FoxBASE+ is a supercharged dBASE, with all the features Ashton-Tate forgot. If you're into serious dBASE development and have not tried FoxBASE+, you are living in the dark ages and wasting your company's money."

George F. Goley IV, *Cont. Editor, Data Based Advisor*:

"The product is fast, very compatible, fast, easy to use, fast, relatively inexpensive, and very fast. In every test, FoxBASE+ outperformed the other products. And people who answer the phone at Fox know what they are talking about."

David Irwin, *Former President/CEO, Data Based Advisor*:

"From the dBASE compatibility standpoint, FoxBASE+ is flawless. From the speed standpoint, FoxBASE+ is unbelievable. From the "lazy factor" standpoint, FoxBASE+ is perfect."

Glenn Hart, *Contributing Editor, PC Magazine*:

"Initial tests of FoxBASE+ were simply stunning. In many ways, FoxBASE+ gives you the best of both worlds: all the benefits of interactive development and debugging, plus the speed and code protection of a compiler."

Adam Green, *Contributing Editor, Data Based Advisor, dBASE Author*:

"For the PC, FoxBASE+ has consistently set the performance standard for dBASE compatible languages. For the Macintosh, FoxBASE+/Mac will set standards for innovation and leadership in a new dBASE implementation."

Don Crabb, *Contributing Editor, InfoWorld*:

"You can expect blazing speed on the Mac. FoxBASE+/Mac breezes past tests that have proven stumbling blocks for Macintosh databases in the past. FoxBASE+/Mac combines complete dBASE compatibility with a genuine Macintosh user interface."

This is what they said about Version 2.00 of FoxBASE+ . Imagine what The Experts will say about New Version 2.10 with these added features: Menu-Driven Interface, Program Documentor, Screen Painter and Template-Based Application Generator . . . and Version 2.10 is even faster than 2.00!

Join The Experts. Get your copy of the New FoxBASE+ Version 2.10 today! Now available at your nearest, quality software retailer, or directly from us by calling (419) 874-0162 Ext. 320.

Because, when it comes to speed, compatibility and value, nothing runs like the New FOX—Version 2.10!

See us at COMDEX/Spring '89, Booth #7830

Fox Software

Nothing Runs Like a Fox.

Fox Software
118 W. South Boundary
Perrysburg, OH 43551

(419) 874-0162 Ext. 320.
FAX: (419) 874-8678
TELEX: 6503040827 FOX

Circle 104 on Reader Service Card

FoxBASE and FoxBASE+ are trademarks of Fox Software.
dBASE and dBASE III PLUS are trademarks of Ashton-Tate.
Macintosh is a trademark of Apple Computers, Inc.

When you create PC database applications without Clipper,[®] you place unnecessary restrictions on yourself.

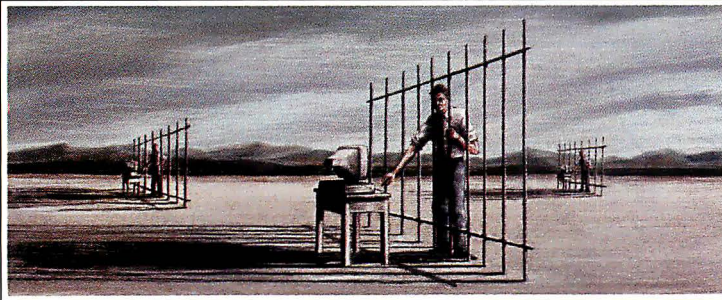

Sometimes we get so accustomed to being confined we forget there are better alternatives.

Specifically designed for creating sophisticated applications, Clipper[®] takes you far beyond the limitations of other PC database development systems.

Clipper's open architecture, for example, allows user-defined functions as well as outside routines written in Assembler, C and many other languages, to be easily integrated into one seamless application.

In addition to its ability to work with the dBASE[®] language, Clipper provides new language extensions and enhanced commands for creating menus, screens, windows, arrays and input validation. All saving hours of coding time.

It offers a full-featured Debugger. A customizable error system to create your own error recovery strategy. Sophisticated record and file locking capabilities that make networking applications easier to create. And runs applications up to 20 times faster than dBASE.

What's more, Clipper produces .EXE files which free you from runtime modules, licensing costs, royalty fees, and additional software requirements.

Clipper.

Everything you've been asking for in a database development system. With a degree of freedom you've never experienced. The question now is, just how locked into your old ways are you?

For a free demo diskette and booklet, *Developing and Compiling with Clipper*, call (213) 390-7923.

Clipper[®]

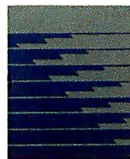

Nantucket Corporation, 12555 West Jefferson Boulevard, Los Angeles, CA 90066. fax: (213) 397-5469, telex: 650-2574125
Copyright © 1989 Nantucket Corp. All rights reserved.
Clipper, Nantucket and the Nantucket logo are registered trademarks of Nantucket Corp. Other brand and product names are used for identification purposes only and may be trademarks or registered trademarks of their respective holders.

Ethical Medicine

Many people are alarmed about computer viruses. The final solution to these viruses involves more than technology.

Writing a program that disrupts and destroys computer activity is an expression of immaturity, economic pressure, or the fear of military systems. Usually, the motivation is to magnify one's ego or to get revenge on an employer. Sabotaging a competitor's products and mucking the military are distinct possibilities as well.

The final solution to this sickness includes a vision that can excite our imaginations along more positive paths. It is a vision of making all human knowledge immediately accessible to any person, anywhere on planet earth. It is a vision of enabling each individual to live to the fullest of his or her potential. It is a vision of well-being and wholeness in which a healthy information system is an essential part.

John Baltzer
St. Louis, MO

Your Check Is in the Mail

Although I am not new to computers, I have been away from them for eight years due to my career studies. My love for computers began about 14 years ago, when the Z80 chip, CP/M, and BASIC were the ruling clan of the microcomputer world.

This world has changed for the better. Now we have the Intel 80386 chip, OS/2, and C, the ruling clan of this modern era. Things that we could only dream of then are second nature for Those Software Packages and Their Magnificent Computing Machines.

Today's computer world could have been very intimidating for a neophyte like me. But not anymore, thanks to BYTE and its knowledgeable staff. Thanks for giving me the best source of information month after month to keep my long-enduring love for those amazing silicon wonders strong and growing.

Carlos A. Arche
Caguas, Puerto Rico

We Are Not Amused

So the Russians are coming, are they? (Editorial, October 1988). After reading editor in chief Fred Langa's report about the software demonstrated by the Soviet delegation, we were anxious to download the programs from BYTenet (a process that took a very long time at 1200 bps—please note that the price of 2400-bps modems in your advertisements has come down considerably) and run them.

continued

PC EXPERTS AGREE:

Proteus® offers the fastest for the least, and supports them the most.

Proteus® sells the fastest personal computers you'll find. But as experts from BYTE, InfoWorld, Personal Computing, and others have discovered, our computers are more than just fast.

"The Proteus is an excellent value for the performance it offers potential buyers. Its speed, expansion capability, and service contract put it in a class with the big boys."

Personal Computing Magazine

"You get... fifteen months of service coverage—and onsite at that. Even without the warranty, we highly recommend this machine."

Computer Buyers Guide

"A remarkable range of performance and operational capabilities."

Ed McNierney, BYTE Magazine 8/88

For the fastest, most economical, best supported computers available, follow the experts to Proteus.

"This IBM-compatible is so fast I have had trouble measuring its speed."

Business Computer Digest

"Proteus is markedly faster than any other personal computer we've worked with, including Deskpro 386/20."

Personal Computing Magazine

"The Proteus is one of the fastest desktop computer systems we tested, a zero-wait-state hot rod."

InfoWorld Magazine

"... a complete multi-user solution that arrives with all peripherals and operating systems installed and tested... a very powerful machine that does what it claims."

Computer Shopper Magazine

PROTEUS-286GTX

12MHz, ZERO WAIT STATE

- Intel 80286-12 CPU
- 640K RAM expandable to 16MB
- 32KB cache memory
- 8 expansion slots
- 2 serial & 1 parallel port
- 1.2MB floppy drive or 3.5" microfloppy
- Dual HD & floppy controller
- 200W power supply, 110/220V
- 101 key tactile keyboard
- 15-month free on-site service
- Made in U.S.A.

Complete Systems with Hard Disk and Monitor:

- 20MB mono \$1,905
- 20MB EGA plus color \$2,350
- 20MB 16-bit VGA \$2,780
- for 40MB add \$142
- for 80MB add \$445

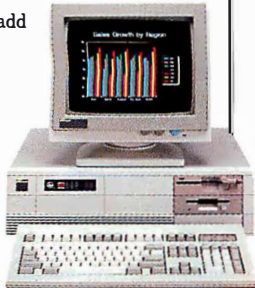

PROTEUS 386/16

16 MHz opt. 20MHz ZERO WAIT STATE

- Intel 80386 CPU at 16 MHz
- Optional 80386-20MHz
- 1MB RAM—Expandable to 16MB
- Intel 82385 EE cache ctlr
- 32K fast cache
- 2 serial & 1 parallel port
- 1.2MB floppy drive
- Dual HD & floppy controller
- 200W power supply, 110/220V
- 101 key tactile keyboard
- 15-month free on-site service
- Made in U.S.A. **\$2,195**

Complete Systems with Hard Disk and Monitor:

- 40MB 28ms mono \$2,899
- 40MB 28ms EGA plus color \$3,299
- 40MB 28ms VGA plus \$3,699
- for 80MB add \$185
- for 100MB add \$614
- for 150MB add \$1,420
- for 340MB add \$2,675

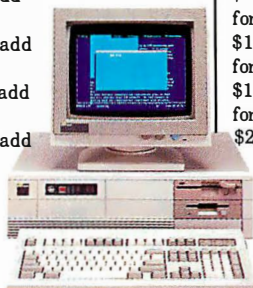

PROTEUS 386/25

25MHz, ZERO WAIT STATE

- Intel 80386 CPU at 25MHz
- 1MB RAM expandable to 32MB
- Intel 82385EE cache ctlr
- 32K fast cache
- 387 coprocessor support
- 2 serial & 1 parallel port
- Dual HD & floppy controller
- 200W power supply, 110/220V
- 1.2MB floppy drive
- 101 key tactile keyboard
- 15-month free on-site service
- Made in U.S.A. **\$3,995**

Complete Systems with Hard Disk and Monitor:

- 40MB 28ms mono \$5,199
- 40MB 28ms EGA plus color \$5,599
- 40MB 28ms VGA plus \$6,069
- for 80MB add \$185
- for 90MB add \$1,129
- for 150MB add \$1,545
- for 340MB add \$2,675



PROTEUS SYSTEM 3400M MULTIUSER SYSTEM

- 80386-20MHz, optional 25MHz
- 2MB 32-bit RAM, Exp to 32MB
- 80MB 28ms HD, up to 4.5 GB
- Opt 1/2ms instant disk access
- 40MB tape streamer, opt 150MB
- 8 terminal support, exp to 32
- PC-MOS, Xenix or Unix loaded
- Hi res 14" CRT and adapter
- Fiber optics LightWave graphics workstations
- 2 parallel and 2 serial ports
- 6 or 8 half height drive bays
- 101 key Enhanced keyboard
- Optional brand name terminals
- Standard System Price \$6,980
- * Special System Sale **\$5720**



To order, call us direct. 1-800-782-8387

In N.J. call 201-614-7000

For 24 hr catalog, call 1-800-548-5036 using your modem set at 1200B or 2400B/N/8/1. Technical Support Hotline: 1-800-541-8933 Reseller/VAR programs available.

Custom configurations available.

All trademarks recognized. © Proteus is a registered trademark of Proteus Technology Corp. All prices, terms, specs subject to change.

Circle 227 on Reader Service Card

proteus
THE INTELLIGENT CONCLUSION
75 Kingsland Ave.,
Clifton, N.J. 07014

APRIL 1989 • BYTE 27

EVEREX

Everex, Snap and AUSA are trademarks of Everex Systems, Inc. All other product names are registered trademarks of their manufacturers.





**"If this is a race, we
are out in front."**

Steve Hui, President
Everex Systems, Inc.

IBM PS/2 Model 80 (20 MHz)	3.52 MIPS
Compaq DeskPro 386/20	4.59 MIPS
Everex Step 386/20	4.91 MIPS

Power Meter MIPS Version 1.2. The Database Group.

**"We created a
monster."**

Apparently, we
have surprised a
few people. It's not
every day that
someone builds
the world's fastest
386/20.

Our marketing
people call the con-
cept AMMA—for
Advanced Mem-
ory Management
Architecture.

I don't care what
you call it. This is
the computer that
has left everybody
behind, including
Compaq.

For the moment, we
are overjoyed.
But this is a game
of leapfrog and
we do not intend
to rest.

The Step 386/20
from Everex
is a monster of
a machine.

For price and
performance facts,
call Everex
Computer Systems
Division at 1-800-
356-4283. Everex,
48431 Milmont
Drive, Fremont,
CA 94538.



While the software was entertaining and unusual, we found three areas worthy of comment.

The first thing we noticed was the flashy interface complete with startling sound effects. In fact, the sounds bore an uncanny resemblance to the sounds that can be heard emanating from the computer room when our sons are down there playing.

The authors of the software seem to have made the same mistake that a lot of

other authors make—that is, to confuse a flashy interface with a user-friendly interface.

While the screen layout was very good and the exploding windows fit in very well, the actual text was anything but user-friendly, and the sound effects were distracting, even annoying, in this context. (Besides, we kept wondering whether they were lifted directly from the code of some commercially available games.)

The second area we noted was the

thrust of the programs themselves. We should be flattered that the Soviets think that the general intellectual level of the American public is so high, but the truth is that the programs will have limited appeal in the general market, aside from the ivory-tower crowd.

Finally, we were interested in the Soviets' use of the English language. We are impressed with their command of English but surprised that they didn't at least go the additional step of hiring someone to check spelling, syntax, and idioms. While Americans put up with manuals that are written in some oriental language and then translated into English because the hardware works, when the use of the product itself is impaired because of the language problem, we doubt Americans will be so tolerant.

Overall, we give the Soviets a good grade for a first effort at competing in the U.S. market, but we still don't think they're here yet. We also doubt their claim that, "Without any exaggeration, the NeMo-Tec can be considered as an example of the software technology of the next decade—or even of the next century."

Chris Bidstrup
Idaho Falls, ID
Kent Howcroft
American Fork, UT

Intuition and Theory

I would like to add to R. N. Bracewell's terse dismissal (Letters, November 1988) of the point made in John C. Polasek's letter (August 1988). Polasek's point is born of good intuition and has also been put forward by some of my colleagues in the past. This being the case, I thought it might be useful to offer what might constitute a reconciliation of intuition with theory.

On the surface it would appear, from a functional analysis point of view, that the function set $(\cos(wt) + \sin(wt))$ does not form a complete basis set, even for real functions. In other words, the null space of the Hartley mapping is by no means empty, and while it is true that neither of the basis functions represented by the complex Fourier kernel is orthogonal to the "cas" kernel, many functions formed by linear combinations of them seem to be. For example, one might ask, What is the Hartley transform of the set $(\cos(ut) - \sin(ut))$, which is orthogonal to the "cas" kernel... or is it?

This valid question, on further examination, leads to a very simple reconciliation: The Hartley transform and its inverse are mapped into \pm frequency and

continued

ONLY FORTRON COMES WITH ONE FULL YEAR OF SERVICE. FREE. ON-SITE.



NetSet™ 286
NEAT, low 3" profile,
10, 12, 16, 20 MHz

80386 File Server
16, 20, 25, 33 MHz.

DeskTop 286, 386
10, 12, 16, 20 MHz.

When you buy any Fortron 286 or 386-based IBM-Compatible, one full year of service at your site is part of the package. Just call the service hot line, and we'll take care of you from a network of 300 service locations throughout the country.

Because we build our systems right here, you always know exactly who to call for any kind of support you need. And you'll get it, Fast, with no hidden cost.

Here's your chance to be your own PC dealer by dealing directly with Fortron, service and savings, that's the Fortron Difference.

To Order Call Toll Free
800-821-9771

FORTRON

Fortron/Source Corp.

6818-G Patterson Pass Road, Livermore, CA 94550
Telex: 559291 in CA 415-373-1008 Fax: 415-373-1168

Of the more than
250 hardware products reviewed
by InfoWorld in 1988,
our CompuStar[®] received
the highest total score awarded.

CompuStar[®]

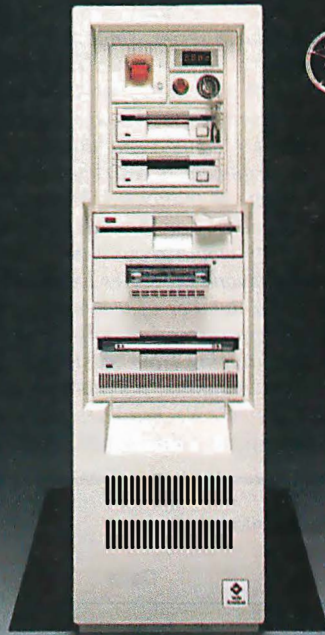

See us at
COMDEX/Spring '89
April 10-13, 1989
McCormick Place
Chicago, Illinois
Booth 8671

Simply stated, it's number one.

CompuStar is the world's first and only multi-processor, convertible bus™ microcomputer. It can be configured with up to 13 bus expansion slots (PS/2 and/or PC/AT compatible), your choice of interchangeable 8086, 80286, or 80386 microprocessors and up to seven disk/tape devices.

To receive a reprint of the InfoWorld review, as well as a complete CompuStar product information kit, call 803/796-7800.



Corporate Headquarters: 3243 Sunset Boulevard • West Columbia, South Carolina USA 29169 • 803/796-7800 • FAX 803/796-7092

PS/2, Personal Computer AT and AT are trademarks of International Business Machines.

Circle 295 on Reader Service Card

\pm time. The "negative frequency" component of the transform does contain the information represented by the basis set $(\cos(ut) - \sin(ut))$. That is, $(\cos(-wt) + \sin(-wt))$ is identical to $(\cos(wt) - \sin(wt))$. Thus, the seemingly missing, orthogonal component of the Hartley kernel is represented by the mapping into a "negative frequency" range, with the phase information preserved in the relative positive and negative components at each frequency.

Though, in this case, you find an intuitive oversight, I think it illustrates the importance of submitting a formal proof to the acid test of good scientific intuition and resolving any apparent contradictions. All too often, only the reverse is done.

Ron G. Walters
Cleveland, OH

No Coprocessor

In "Floating-Point without a Coprocessor, Part 2" (October 1988), Rick Grehan says to use Taylor-series expansions for the implementation of the trigonometric functions. I disagree. Taylor functions have terrible convergence when high decimal-point accuracy is desired. Instead, I recommend the following approximation for the sine function (x is in radians):

$$\sin(x \times \pi/2) = c_1x + c_2x^3 + c_3x^5 + c_4x^7 + c_5x^9$$

where

$$\begin{aligned} c_1 &= + 1.5707\ 9631\ 847 \\ c_2 &= - 0.6459\ 6371\ 106 \\ c_3 &= 0.0796\ 8967\ 928 \\ c_4 &= - 0.0046\ 7376\ 557 \\ c_5 &= + 0.0001\ 5148\ 419 \end{aligned}$$

This approximation has an error of $\pm 0.0000\ 0000\ 5$, which translates into eight-decimal-place accuracy. I coded this function on my Apple Lisa and obtained the comparison ($f(x)$ is the approximation) in table 1.

For a very good list of function approximations, I recommend *Approximations for Digital Computers* by Cecil Hastings Jr. (Princeton University Press, 1955).

David Craig
Wichita, KS

You are correct in that the Taylor-series expansion I gave (actually, it should be called a McLaurin series, since that's the term used for a Taylor series expanded around $x = 0$) for $\sin(x)$ isn't the best for digital computer use. Though it might be passable for some computations as long as the argument is restricted to the first quadrant, a truncated McLaurin series with accuracy on the order of your example's 10^{-8} would require two additional terms beyond the series I showed.

There are a number of techniques for deriving an approximating polynomial's coefficients, ranging from least-squares regression to minimax polynomial approximations. F. R. Ruckdeschel, in BASIC Scientific Subroutines, Vol. 1

(BYTE Books, McGraw-Hill, 1981) presents a least-squares analysis program and uses it to generate an approximating polynomial for $\sin(x)$ good to an accuracy of about 10^{-14} . The results are shown in table 2. Keep in mind that, when working with series approximations like this, you should construct your algorithm so that the higher-order terms are accumulated into the result first so that you avoid errors generated by adding small numbers to large numbers.

Also, I don't think your definition of radians is quite right, since 1 radian is 57° and $\sin(\pi/2 \text{ radians}) = 1.0$.

—Rick Grehan

Impressive Workstation

Thanks for an interesting look at the NeXT workstation. The system is impressive in all respects except for the slow access time of its primary storage device. I wonder whether common sense was overridden by the call of the wild, especially since Unix performance is directly related to disk performance.

I don't wish to belittle the importance of the new optical drive. The removable high-capacity read/write optical disk is truly revolutionary, particularly in its implications for data backup and security. A drive failure means that you could swap out the bad hardware, slide in the backup media, and boot back up, drastically cutting downtime. Sensitive data can now be physically removed from the system (not just erased) and locked up at night. The 60-megabyte streaming tape drive would no longer be the standard backup device since the backup could be from disk to disk. Sounds great.

I hope NeXT decides to give the marketplace a break and offer a more conventional high-performance (5-millisecond?) hard disk drive as the primary drive. Nowhere is it written that you cannot be radical and open-minded at the same time.

Peter Matsunaga
Aiea, Hawaii

Table 1: Coefficients for $\sin(x)$ accurate to eight decimal places.

x	$f(x)$	$\sin(x \times \pi/2)$	Delta
0.000	0.000000000000	0.000000000000	0.000e+ 0
0.200	0.30901699496	0.30901699437	- 5.813e- 10
0.400	0.58778525441	0.58778525229	- 2.1173 - 9
0.600	0.80901699004	0.80901699437	4.333e - 9
0.800	0.95105652100	0.95105651630	- 4.707e - 9
1.000	1.00000000531	1.00000000000	- 5.310e - 9

Table 2: Power series approximation for $\sin(x)$ accurate to approximately 10^{-14} over the range $-\pi/2 \leq x \leq \pi/2$.

Coefficient	Value
c_1	- 0.1666666666671334
c_2	0.008333333333809067
c_3	- 0.000198412715551283
c_4	0.0000027557589759762
c_5	- 0.00000002507059876207
c_6	0.000000000164105986683

Where to NeXT?

Thank you for your complete report on NeXT's cube computer ("The NeXT Computer" by Tom Thompson and Nick Baran, November 1988). I am a computer engineer at the University of Oklahoma, and the machine sounded perfect for me, so I immediately set out to buy one.

I asked the people at our purchasing office about the machine, and they said they had not been contacted by NeXT and would not carry the company's ma-

continued

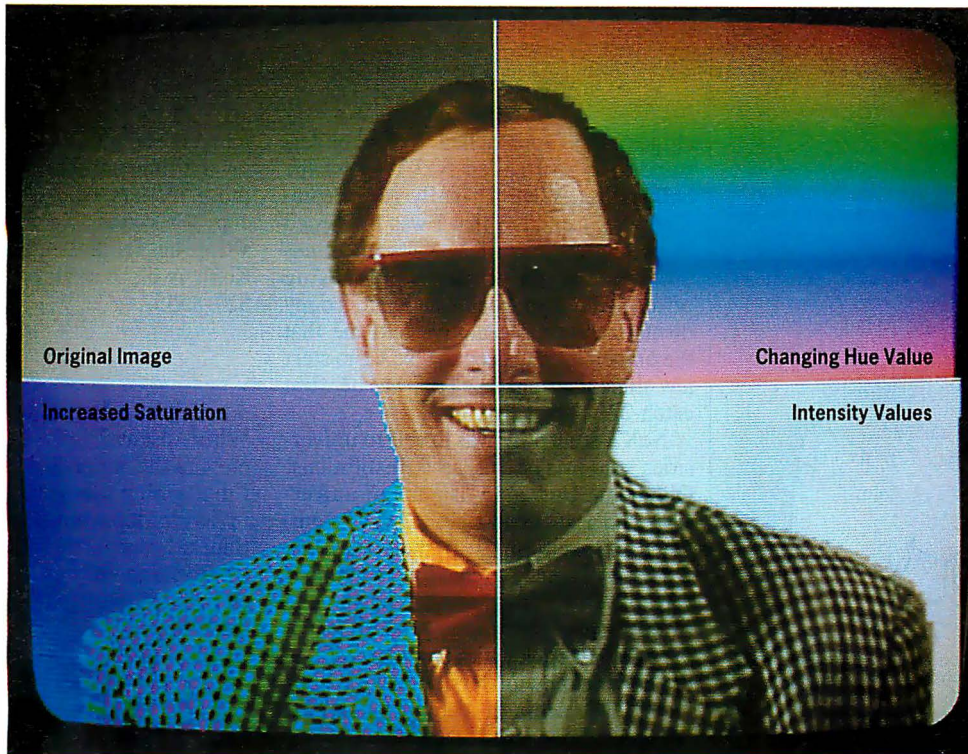

Our (HSI) Color™ Frame Grabber lets you change your image as fast as you change your mind.

Welcome to the real-time world of color image processing.

If you work in a high speed environment with an IBM PC AT or compatible, you already know how complex and time-consuming RGB color processing is. In contrast, HSI processing lets you manipulate hue, saturation, and intensity independently and in real-time. Add *that* to your power and memory!

Our DT2871 (HSI) Color™ Frame Grabber with its Aurora™ software simply facilitates and accelerates conventional color image processing. Take a quick look at the "split personality" above and see why.

The image on the upper left shows Data Translation President, Fred Molinari's true colors in a frame captured directly from a video camera. Then, to illustrate the broad range of colors available to you, we changed the background hue value in the upper right image. Next we increased the saturation on Fred's shirt and tie, and adjusted both the RGB and HSI values on his snappy jacket. And

finally, we dropped out the color to show the intensity values—all in real-time.

So, whether your application involves animation, cosmetic analysis, robotic vision or quality assurance on fruits and vegetables, our DT2871 is the real-time solution for color image processing you've been looking for.

Call (508) 481-3700
In Canada, call 1-800-268-0427.

Business, Graphic Arts, and Entertainment	Scientific	Industrial
Animation Electronic prepress Electronic publishing, either true color or gray scale Film colorization Picture databases Slidemaking Training	Astronomy Medical diagnostic imaging Microscopy Modeling Motion analysis Remote sensing Surveillance	Machine guidance Machine vision inspection — Agriculture (fruits and vegetables) — Cosmetics — Electronic components — Food — Textiles Robot guidance

DATA TRANSLATION®

World Headquarters: Data Translation, Inc., 100 Locke Drive, Marlboro, MA 01752-1192 USA, (508) 481-3700 Tlx 951646

United Kingdom Headquarters: Data Translation Ltd., The Mulberry Business Park, Wokingham, Berkshire RG11 2QJ, U.K. (0734) 793838 Tlx 94011914

West Germany Headquarters: Data Translation GmbH, Stuttgarter Strasse 66, 7120 Bietigheim-Bissingen, West Germany 07142-54025

International Sales Offices: Australia (2) 662-4255; Belgium (2) 735-2135; Canada (800) 268-0427; Chile (2) 25-3689; China (408) 727-8222, (1) 868-721; Denmark (2) 274511; Finland (90) 372-144; France (1) 69077802; Greece (1) 951-4944, (31) 527-039, (1) 361-4300; Hong Kong (5) 448963; India (22) 23-1040; Israel (3) 5401524; Italy (2) 824701; Japan (3) 348-8301, (3) 502-5550, (3) 355-1111; Korea (82) 756-9954; Morocco (9) 30-4181; Netherlands (70) 99-6360; New Zealand (9) 504759; Norway (2) 53 12 50; Peru (14) 31-8060; Philippines 818-0103; Portugal 545313; Singapore 7797621; South Africa (12) 8037680/93; Spain (1) 455-8112; Sweden (8) 761-7820; Switzerland (1) 723-1410; Taiwan (2) 918-4740; United Kingdom (0734) 793838; West Germany 07142-54025.

(HSI)Color Frame Grabber is a trademark and Data Translation is a registered trademark of Data Translation, Inc. All other trademarks and registered trademarks are the property of their respective holders.

See us at Electronic Imaging West, Booth 509.

ChiWriter

Powerful Scientific/Multifont Word Processing at a Reasonable Price

How are you currently producing your scientific documents? Are you using a "golf ball" style typewriter? A regular word processor, hand lettering the special symbols? Are you fighting against a "what-you-see-is-definitely-not-what-you-get" system with a special command language? Or are you using one of our competitors' expensive and inflexible programs? Find out how ChiWriter can solve your scientific word processing problems.

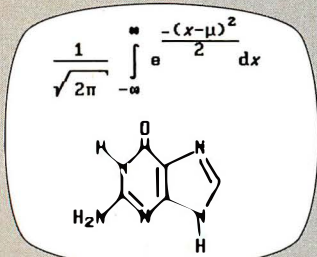

From an actual ChiWriter screen display

ChiWriter is a complete word processor, designed especially for scientific and foreign language text. Its features include: intuitive formula editing commands, automatic pagination, variable headers and footers, footnotes, box draw mode, a notepad window, and an integrated spelling checker.

Best of all, ChiWriter is completely "what-you-see-is-what-you-get." Even complicated formulas can be entered easily because the screen display corresponds exactly to the printout.

ChiWriter runs on IBM PC compatibles with 2 floppy disks or a hard disk, 384K RAM and CGA, Hercules, EGA, VGA or AT&T graphics. Support for all popular dot-matrix printers is included. The Laser Printer Support is required for HP LaserJet, DeskJet and PostScript printers.

"ChiWriter is a nifty product with a price I defy you to beat and performance I defy you to snub ... I know of several \$500 programs that will do the job, but for the same money you could buy ChiWriter and a vacation."

Phil Wiswell, PC Magazine

- ChiWriter Program \$149.95
- Laser Printer Support \$74.95
- WordStar/WordPerfect Converter \$59.95
- Chemistry Font Set \$59.95
- Russian Font Set \$29.95
- ChiWriter Deluxe (all of the above) \$299.95
- Conographic Font Set \$149.95
- MergeChi Mail Merge Program \$29.95
- IndexChi Index Generator \$59.95
- Check here for 20% educational discount**
(school and university teachers and students only)
- Shipping & handling \$ _____
\$5 U.S. & Canada, \$10 Europe, \$15 elsewhere

Name _____
 Address _____
 City _____
 State _____ Zip _____ Country _____
 Phone (_____) _____
 Payment by Check Purchase Order VISA MC
 Card # _____ Exp. _____

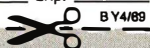

Horstmann Software Design Corporation
 140 E. San Carlos St./P.O. Box 5039
 San Jose, CA 95150-5039, USA
 (408) 298-0828, FAX (408) 298-6157



horstmann software

LETTERS

chines unless approached. I could understand that, so I called NeXT to get the ball rolling. When I finally got a representative, I told her that I was interested in purchasing one of NeXT's machines but that the university's purchasing office had not yet been contacted. To my dismay, the representative told me that the university must contact NeXT to start any student purchases. That was my first catch-22.

NeXT's purpose was to sell to universities and major research institutions. Oklahoma University is a major university, and I still can't get a NeXT computer. I asked NeXT if there was any other way I could purchase its machine. I was told that I could try purchasing one from another university. Great! Except the person I spoke with wouldn't tell me the name of any university that was selling NeXT machines. Another catch-22.

I started out really wanting this computer. It still is an incredible piece of hardware, but until NeXT changes its policies, I would not recommend anyone buying one.

Scott Fields
 Norman, OK

One Year Later

In the April 1988 issue of BYTE, you published a letter of mine suggesting the use of the work by Michael F. Barnsley and Alan D. Sloan ("A Better Way to Compress Images," January 1988) for the compression of databases.

The method did indeed compress the databases about 100 to 1 in most cases. However, Barnsley and Sloan's method is lousy, and as a result the data when decompressed was not exactly the same as the data before decompression. However, the method did discover underlying patterns in the data.

The discovery of these patterns allowed the development of a better access system to the data, sometimes increasing access to connected pieces of data by 50 to 1. More important, it allowed the discovery of connections within the data structure that were not thought to exist.

The ability to discover connections within a database does have interesting implications for expert systems and relational database structures.

Robert McLaughlin
 Arlington, VA

Buy the Book

I greatly appreciated Jerry Pournelle's generous comments in his December 1988 Computing at Chaos Manor about our new book, *LaserJet Unlimited, Edition II*. Unfortunately, although the

name of the publisher was listed, no city or mailing address was included. For those readers who would like to buy a copy, it's available for \$24.95 plus \$3 shipping from Peachpit Press, 1085 Keith Ave., Berkeley, CA 94708, (415) 527-8555.

Ted Nace
 Berkeley, CA

An Orphan Variable

While discussing the creation of contour plots in the computational statistics class I'm teaching this semester, my class and I tried to duplicate figure 1a in Paul D. Bourke's June 1987 article entitled "A Contouring Subroutine." The article claims that the figure is a contour map of the function

$$f(x,y) = \sin((x^2 + y^2)^{1/2}) + \frac{.5}{\sqrt{(x+3.05)^2 + y^2}},$$

$$-2\pi \leq x, y \leq 2\pi.$$

When we were unsuccessful in producing a plot similar to the one in the article, a careful inspection of its listing 2 revealed the line

$$d(i,j) = \text{SIN}(r) + .5 / \text{SQR}((ix+3.05)^2 + iy^2)$$

Unfortunately, the variable *iy* is never defined in the program (presumably Bourke intended to type *iy* instead of *iy*). This has the effect of leaving out the *y*² in the second term of the function, which has a drastic effect on the function. I do not consider myself a programming purist, but an experience such as this goes a long way toward making me want to use languages that require all variables to be declared before they can be used.

H. Joseph Newton
 Professor of statistics
 Texas A&M University

Time-slicing

I am writing with regard to Mark Minasi's "OS/2's Multitasking Dashboard" (OS/2 Notebook, November 1988). Minasi is unable to explain why background processes get proportionately more CPU time as the time slice is increased (table 3 in the article). As far as I can work out, it is because when you increase the time slice, the ration of maxwait to time-slice decreases.

As an example, say there is one foreground and one background process running with maxwait=1 (second) and priority=dynamic. If the time slice is

continued

1024X768 IBM COMPATIBLE VGA VIDEO CARD

VGAWONDER™

T H E S E C O N D W O N D E R

1024X768

Plus: VGA, EGA, CGA, MDA & Hercules on Standard MULTISYNC monitors

Yes! the Phenomenal VGAWONDER does it all at IBM Hardware level compatibility with automatic monitor detect and no dip switches or jumpers to set. A HOT CARD for the 286/386 POWER USER with AUTO BUS DETECT for 8 or 16 bit slots, running with a 16 bit datapath with 1:1 interleave. 100% IBM HARDWARE LEVEL COMPATIBILITY means that ALL software and operating systems designed for IBM systems will run. 1024 WILL BE DISPLAYED IN COLOR ON STANDARD MULTI-FREQUENCY MONITORS. Although these features are expected from ATI they are NOT AVAILABLE from other manufacturers. EGA on all monitors including RGB & TTL means a perfect card for networks. MOUSE ON BOARD! ATI built the mouse right in to this one, why not? No extra charge! VGAWONDER is available in both 512K and 256K Versions. Ask your dealer for more information.



TECHNOLOGIES INC.

Technology you can Trust.

ATI Technologies Inc.
3761 Victoria Park Ave., Scarborough, Ontario
Canada M1W 3S2 Telex: 06-966640 (ATI TOR)
Tel: (416) 756-0718 Fax: (416) 756-0720



See us at
COMDEX/Spring '89
April 10-13, 1989
McCormick Place
Chicago, Illinois
Booth 418

ATI, VGAWONDER — ATI Technologies Inc.; Multisync — NEC Home Electronic Inc.;
AUTO CAD — Auto desk Inc.; WINDOWS — Microsoft Inc.; GEM — Digital Research Inc.;
VENTURA — Xerox Corp.; HERCULES — Hercules Computer Technology Inc.;
IBM, VGA, EGA, CGA — International Business Machines Corp.

Circle 30 on Reader Service Card

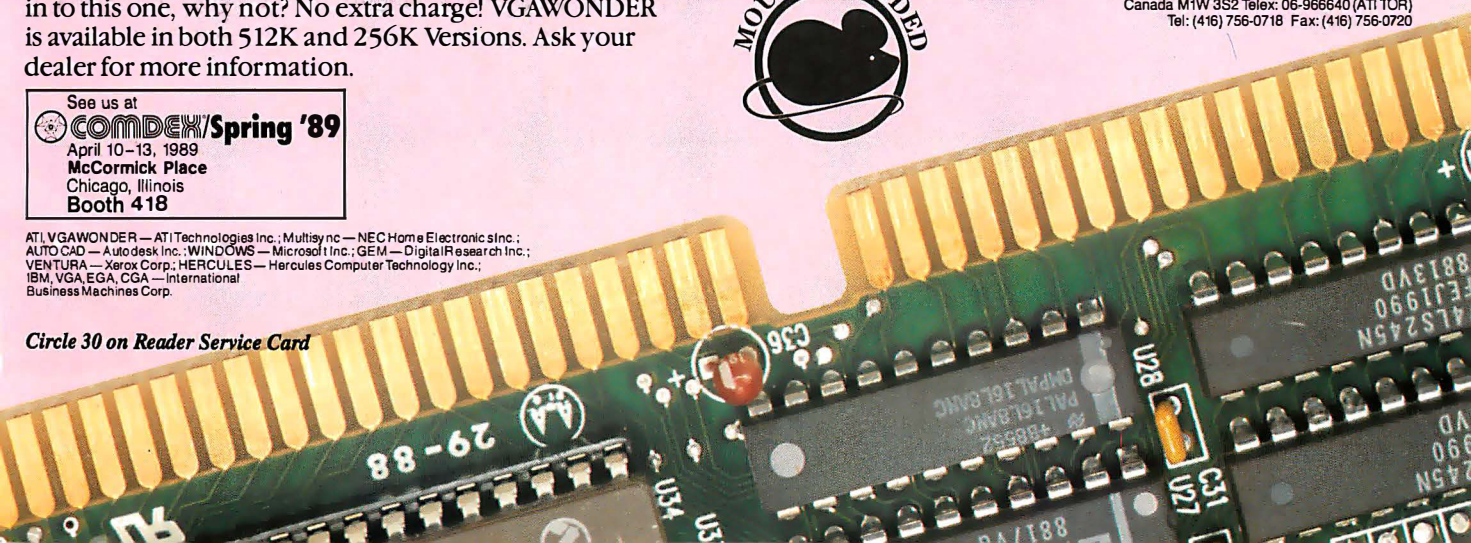

We keep telling people
this is not a laser printer.

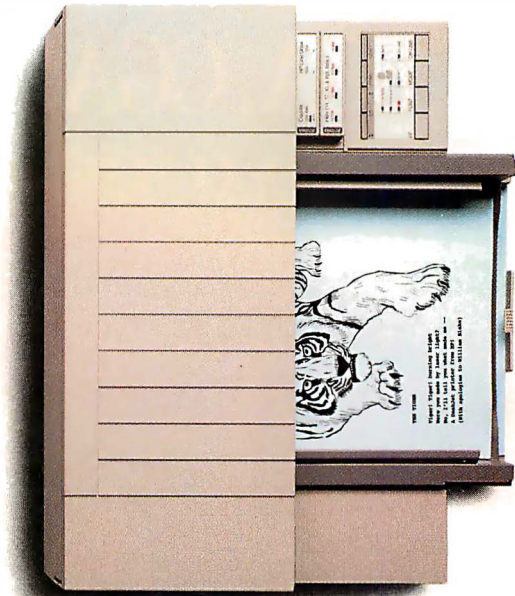

The \$995 HP DeskJet Printer.

But they keep looking at the evidence.



Mr. Arnold R. Jones
220 Bush Street, Suite 845
San Francisco, CA 94104

Dear Reader:

Imagine being able to put out merged text and graphics that look in fact, that your clients will think you're using a laser printer. Then you're using the \$995 HP DeskJet printer instead.

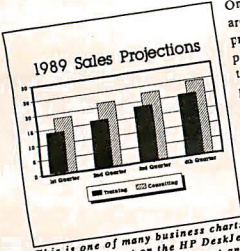

This is one of many business charts you can print out on the HP DeskJet printer. Software for this text and graphics demonstration by Harvard Graphics.

Sincerely,

Alan Grube
Alan Grube

One reason you can't get around so easily is that your printer works with packages. So you can't use the PC, with you can't print it out quite

We call it a printer. Small price, fast

Of course, how good a trip to your printer is for yours

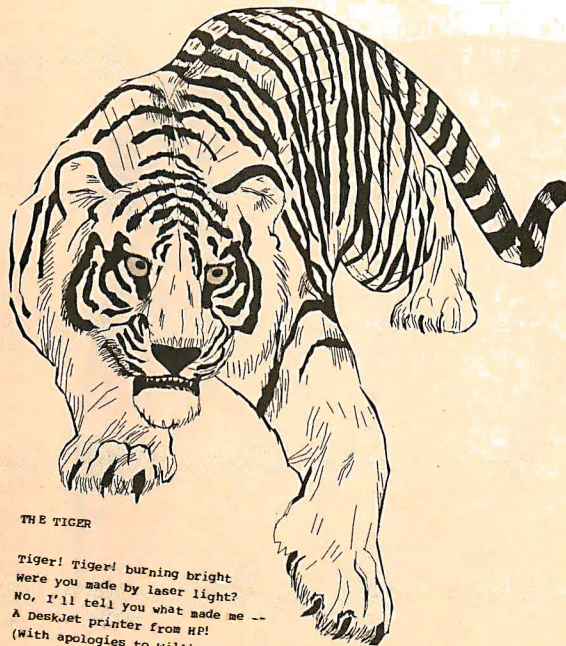

THE TIGER

Tiger! Tiger! burning bright
were you made by laser light?
No, I'll tell you what made me --
A DeskJet printer from HP!
(with apologies to William Blake)

MegaCorp 1988 Sales History

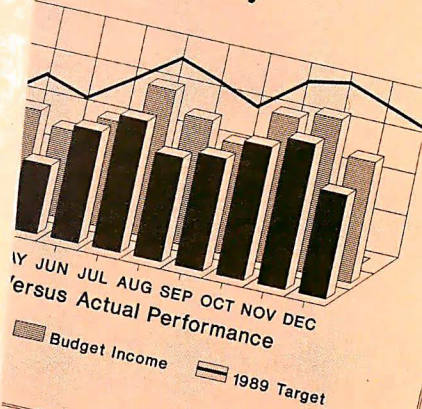

You may not believe your eyes, either. The HP DeskJet printer gives you the same crisp, black lettering. And clean, sharp graphics. But it uses advanced ink-jet technology to give you these laser-like qualities for the price of a 24-wire printer.

For just \$995, you get 300 dpi in a trim 15-pound package that sits easily on your desk. It has four built-in fonts, and over 100 optional fonts available in plug-in cartridges. With a 20,000-hour MTBF, it will keep working away for a long, long time. And it will do it all in blissful quiet.

So don't settle for a noisy dot matrix printer. Instead, call **1-800-752-0900, Ext. 296J** for a brochure and your nearest authorized HP dealer. Then judge the HP DeskJet printer for yourself.



DRAFIX CAD ULTRA™ FINALLY FILLS AN IMPORTANT GAP IN LOW-COST CAD.



CADAPULT™ YOUR DRAWING INTO LOTUS 1-2-3 OR DBASE.

Drafrix introduces CAD for the real world.

Any CAD package lets you create drawings. New Drafrix CAD Ultra with CADapult is the first inexpensive CAD software that can turn your drawings into usable database and spreadsheet information.

First, you can give every element in your drawing specific attributes—a name, a part number, a price, for example. Then, with little more than a push of a button, you can convert the data into a spreadsheet, move it into a database or insert it into your drawing.

Suddenly your concept becomes a bill of materials, a component pricing list, an order form, a job estimate.

"SIMPLE TO LEARN AND EXTREMELY EASY TO USE."

—PCWeek

You'll never find an easier CAD software to use. With Drafrix all of the menus are on the screen all of the time—there's nothing to memorize! In minutes you'll create sketches and drawings naturally and effortlessly—drawings that would require weeks of training on other CAD systems.

AMAZING POWER AND SOPHISTICATION FOR ONLY \$395.

All of the drawing, designing and editing functions



demanded by architects, engineers, drafters, contractors and other serious CAD users are included.

- Create your own symbol libraries with attributes or use our pre-attributed, predrawn symbols supplied with the package.
 - Draw lines, arcs, polygons, splines and bezier curves or freehand sketch.
 - Access our full complement of item and grid snaps for superior accuracy.
 - Use our powerful and flexible automatic dimensioning system and crosshatching and solid fill for complex drawings.
 - Take advantage of function key macros for even greater performance.
 - Use the revolutionary word processing window for adding and editing text in drawings.
- Plus much, much more.

EVERYTHING YOU NEED IN A SINGLE PACKAGE.

Other low-cost packages require expensive add-on modules. There's nothing missing from Drafrix CAD Ultra. For no extra cost you get:

- DotPlotter™ for high resolution Dot and Laser Printer output.
- General Symbols Library of 450 pre-drawn objects.
- CADapult exchange utility.
- HPGL compatibility with desktop publishing programs and a full range of pen plotters.

CALL US TODAY.

For the name of your nearest Drafrix dealer, call us today at **1-800-231-8574**.

Ask about **Drafrix 3D Modeler** and **Drafrix CAD Report** too!



FORESIGHT RESOURCES CORP.
10725 Ambassador Dr.
Kansas City, MO 64153
816-891-1040

Circle 100 on Reader Service Card (DEALERS: 101)



SAVE MONEY ON SOFTWARE!

CALL OR WRITE FOR OUR COMPLETE SOFTWARE CATALOG

GAMES

- C#1 - ARCADE GAMES: Crossfire, Bugs, PacMan, Frogger. CGA
- C#19 - PINBALL GAMES I: TwilightZone, Pinball, Wizard, Rain CGA
- C#26 - COMPUTER SOLITAIRE: Klondike, Spider and Canfield CGA
- C#31 - SCRABBLE: Just like the board game! CGA req'd
- C#32 - JEOPARDY! The famous TV game comes to the PC! CGA

MC#1 - MONO ARCADE GAMES:

- PitFall, Bugs!, Pac-Man, Starship
- MC#15 - LOVEFIRE: Romance Textadventure Where will love lead?
- MC#22 - SLEUTH: A murder has been committed and you solve it!
- MC#43 - BASEBALL 20: Great baseball simulation for mono sets.

CLIP ART GRAPHICS

- GR#3 - FIRST PUBLISHER CLIP ART (3 DISKS) Over 50 pcx images
- GR#14 - PRINTSHOP GRAPHICS I: 3 add'l libraries for PntShop pgm
- GR#14B - PRINTSHOP GRAPHICS II: 500 images for PntShop Pgm
- GR#14E - PRINTMASTER GRAPHICS I: 3 libraries for PrintMaster pgm
- GR#14F - PRINTMASTER GRAPHICS II (2 DISKS) 500 images for the PrintMaster program
- GR#28 - VENTURA CLIP ART (5 DISK SET) A collection of clip art with office/business subjects for Ventura Publisher 300DPI
- CL#15 - VENTURA PUBLISHER TUTOR Excellent tutor with utilities!
- GR#32A/B - WORDPERFECT 5.0 ART SET #1 - 4 DISKS Ornate alphabets of the 12th and 15th century. PCCformat at 300DPI
- GR32C/D - WORDPERFECT 5.0 ART SET #2 - 3 DISKS 24 basic icons/26 decorative medallions PCCformat 300DPI
- GR32E/R - WORDPERFECT 5.0 ART SET #3 - 4 DISKS Assortment of 370 images in PCC format.

EDUCATION

- ED#3C - AMY'S FIRST PRIMER: 6 wonderful Kindergarten programs on arithmetic, spelling, color and shape recognition. CGA req'd
- ED#3E - PLAY 'N' LEARN: Alphabet game for 18 months & up plus 6 more pre-school games. CGA req'd
- ED#3G - ELEMENTARY ED: Add, Subtract, Divide, Multiply, Kid's Giant Letter WordProcessor, Funnels & Buckets Math Arcade Game.
- ED#3K - KID'S STUFF: Hangman Word Game, Mosaic design game, Shooting Gallery game. CGA req'd
- ED#4 - GEOGRAPHY I: WorldMap, Geochron, States & Capital games. CGA req'd
- ED#8 - WORLD ATLAS (2 DISK SET) Instant reference to geographic statistics. CGA, 2 floppy drives req'd
- ED#6 - BOOK REPORT & 1001 TOPICS Helps students pick topics and do their book reports
- ED#14D - HIGHSCHOOL VOCABULARY: Multiple choice word drills with re-testing on missed words, and detailed definitions.
- ED#22 - PRE CALCULUS TUTOR: Trig/Algebra for Calc I & Bus Calc
- ED#32 - PROFESSOR WEISSMAN'S ALGEBRA TUTOR 15 integrated programs teach algebra with full explanations, tests, etc.
- ED#5 - NATIONAL GEOGRAPHIC INDEX: For 1957 to 1987
- ED#34 - XY-SEE (2 DISK SET) Interactive algebra/trig/geometry tutor.
- WP#30 - THESAUR V3.5 - Excellent on-line, easy to use Thesaurus.

EGAPROGRAMS

- EG#1C - EGA GAMES #3: EGA Scrabble, EGA-Aldo, EGA-Checkers
- EG#1D - EGA TREK Intergalactic StarTrek game for EGA
- EG#1F - ADVENTURES OF CAPTAIN COMIC Live graphics EGA
- EG#1H - EGA CHESS High res 3-dimensional chess game for EGA
- EG#3H - EGA NAGEL ART DEMO Sophisticated Art-deco style demo
- EG#1K - EGA BLACKJACK! Excellent playing for EGA/WGA

PERSONAL FINANCE

- PF#1 - AM TAX '88 Complete tax preparation for 1040 and all Schedules (A thru SE) Prints forms acceptable to the IRS.
- PF#26 - CHECKBOOK ASSISTANT Maintains personal checking and credit card accounts.
- B#114 - PROPMAN (2 DISK SET) Comprehensive rental property management, accounting & reporting system. Hard Disk req'd

SPECIAL INTEREST

- WP#1 - PCWRITE v3.02 (3 DISK SET) Excellent word processor with spell check, math & foreign characters, column formatting, and more. Over 300 enhancements have been made since v2.71!
- SI#27 TRAVEL DISTANCES Calculates travel in U.S. or World.
- SI#91 BROTHERS KEEPER (2 DISK SET) Genealogy database produces ancestor, descendant, family reports & tree charts, more
- SI#3B - A.C.E. (2 DISK SET) Complete on-screen guide to the night sky performs astronomical calculations, generates charts, etc. CGA
- SI#72 - PROCON FORTUNE Comprehensive astrology and numerology program provides personality analysis and more
- OR#6 BOOK MINDER Complete book cataloging system for your personal library

UTILITIES

- UT#1 - AUTOMENU v4.5 Excellent hard disk menu organizer with mouse support
- UT#6 - SCREEN UTILITIES Emulate CGA on mono systems, screen blankers and much more.
- UT#20 - SECURITY UTILITIES BombSquad, Check-4-Bombs, and other programs to protect your system from Viruses.
- UT#26 - DISKETTE LABEL Several program that create labels with filespecs for 5.25" and 3.5" diskettes.
- UT#27 - LASER SOFTFONTS I (2 DISK SET) - Old English, Script, Helvetica, Italic, and many more for HPLA-II.
- UT#36 - LASER SOFTFONTS II (2 DISK SET) - Large collection of Times-Roman, Century, Helvetica in 30-60 point.

US TOLL FREE ORDER LINE: 1-800-548-7380
CALIFORNIA TOLL-FREE ORDER LINE 800 828-8933

SEND MAIL ORDERS TO:

PdSOFTWAREHOUSE
200 VALLEY DRIVE - #50
BRISBANE, CA. 94005
415 468-5150

\$2.99

Total # of Disks _____
CA Res Sales Tax _____ Ship To _____
Ship / Handling **3.50** _____
Total Enclosed _____

ASK BYTE

tion, but I think Donald Knuth was used ↑↑; that is,

$$x \text{ op}_4 y = x \uparrow \uparrow y,$$

where $x \uparrow \uparrow y$ is partially defined by

$$\begin{aligned} x \uparrow \uparrow 2 &= x^x, \\ x \uparrow \uparrow y &= x^{(x \uparrow \uparrow (y-1))}. \end{aligned}$$

The function op_5 is defined in the same way in terms of op_4 ; that is, the general relationship is

$$\begin{aligned} x \text{ op}_1 y &= x + y, \\ x \text{ op}_m 2 &= x \text{ op}_{m-1} x, \\ x \text{ op}_m y &= x \text{ op}_{m-1} (x \text{ op}_m (y - 1)), \end{aligned}$$

for $m > 1$. An alternative answer, in terms of the more familiar arithmetic functions, is therefore

$$\begin{aligned} \text{Ack}(5, 5) &= (2 \text{ op}_5 (5 + 3)) - 3 \\ &= (2 \text{ op}_5 8) - 3 \end{aligned}$$

but that would be a matter of taste.

It is worth noting that this number is so large that, for example, conversion to binary form is impossible.

Alf P. Steinbach
Ringstad, Norway

Kludge Reduction Exercises

Recently, I wrote a parsing function that would accept up to eight filenames from within my program, storing each filename within an array of a string (i.e., Array [1..8] of string). I opened the files ($\{\$I-\}$) and examined them to see if they existed. I tossed out incorrect filenames. I processed the remaining files and gave the processed files new names ending in .FIL to indicate that

they had been "filtered." I won't show anyone the kludge I came up with, but with Dick Pountain's Before() and After() from "Untangling Pascal Strings" (December 1988), the whole mess reduced to only a few lines of code.

Although, as Pountain correctly states, the Turbo Val() function is happy accepting leading blanks, the same is not true when assigning filenames for Reset() and Rewrite(). For example, opening the file ' IN.DAT' is not the same as opening 'IN.DAT'. If a user decides to separate the files by two or more spaces, the After() function no longer works as desired. Instead of calling Noblanks() for each filename within my string array, I added another function, DoubleCheck(). This function (see listing 1) need only be called once to remove all multiple separators from the input string.

S. Balch
Lucan, Ontario, Canada

ASK BYTE

Disappointing Hard Drive

I wonder if you could advise me on available hard disk drive upgrades for my IBM PS/2 Model 50, which came with a disappointing CMS 20-megabyte 80-milli-second unit using an ST506 interface.

Antony Perakis
New York, NY

Unfortunately, independent companies have yet to penetrate the Micro Channel market. This is no accident. IBM has made it difficult for other vendors to support Micro Channel applications. The Model 50, in particular, causes difficulties for developers. The IBM BIOS supports only 17 sectors per track. Vendors cannot offer high-performance interfaces like run length limited or ESDI. They would either have to convince customers to throw out the IBM BIOS, or they would have to integrate a BIOS chip on the controller board. Since the market is limited to those Model 50 users who wish to upgrade from the included hard disk drive, it's a lot to ask of a vendor. Unlike the Model 60, which offers an extended CMOS RAM where developers have a window for modifications, the Model 50 offers no such luxury.

As of this writing, Adaptec is sampling a SCSI Micro Channel host adapter for OEMs. This product would not only provide an interface for hard disk drives, but it could also be used to add printers,

continued

Listing 1: Reader Balch's function to remove all multiple separators from the input string.

```
Function DoubleCheck(S:String;
                    C:Char):String;
Begin
  Repeat
    S := Before(S,C+C)
          + C + After(S,C+C);
  Until After(S,C+C) = '';
  DoubleCheck := S;
End;

Example One
...
Readln(Tmpstr);
Tmpstr := DoubleCheck(Tmpstr, ' ');
...
```



APPLE AND OOPS. A PEACH OF A PAIR.

Romeo and Juliette. Lucy and Desi. Fred and Wilma. Sometimes couples just seem made for each other. And now when you put Smalltalk/V and your Macintosh together you've got a marriage made in heaven.

Object Oriented Programming was made for Macintosh. Smalltalk/VMac lets you develop Mac applications easier than ever before using the prototype style that Smalltalk is famous for. You also get push-button debugging; multi-processing; complete Toolbox access; MultiFinder compatibility; a rich class library; and a bushel basket of Smalltalk source code. All in our high-performance 32-bit architecture.

Interestingly enough, Macintosh was made for OOPS. Much of the unique hardware and interface design in Mac development

came directly from Smalltalk research. This is no casual affair.

Love, it is written, is not selfish or arrogant. So when you become passionately involved with Smalltalk/VMac, your work is fully compatible with Smalltalk/V on IBM PCs (and clones) operating with DOS, OS/2 and Presentation Manager.

The new Smalltalk/VMac sells for a peachy \$199.95 and comes with our no-questions-asked 60 day money-back guarantee.

If your dealer isn't into OOPS, order toll free, 1-800-922-8255. Or write to; Digitalk, Inc., 9841 Airport Blvd., Los Angeles, CA 90045. Smalltalk/V and Apple. Now there's an appealing couple.

Smalltalk/VMac

The original AnthroCart. Mobile.
Incredibly strong. So many ways to solve
your space and equipment problems.
Choose different sizes. Move
shelves around. Add space saving
options.

AnthroCart. Well designed
Technology Furniture.

Look for our name.



AnthroCart®

Call us for more information: 800-325-3841



Made in U.S.A.
All steel frame construction
Easily holds up to 150 lbs.



ANTHRO

AnthroCart and Technology Furniture are
registered trademarks of Anthro.

**Anthro®
Technology Furniture®**
3221 N.W. Yeon St.
Portland, OR 97210
503-241-7113
Telex: 940103

tapes, or scanners. Another product might let you hook to a network system through the SCSI port. Other Micro Channel products should be appearing soon, but they have been slow in coming. IBM does offer an upgrade path for your Model 50's hard disk drive: a 27-ms, 60-megabyte hard drive for \$1695.—S. A.

Monochrome EGA

There are several expensive multiscan monochrome monitors that can be used with a conventional EGA card. Are there any low-cost monochrome EGA monitors?

Do special EGA cards that are capable of gray-scale shading on TTL monitors offer a good-quality display? Do they suffer from flicker, partial screen display, or distorted aspect ratio on any EGA modes?

Victor G. Apter
Buffalo, NY

EGA supports modes for monochrome display of both text and graphics. Therefore, you have a wide variety of low-cost monochrome monitors to choose from. I prefer the 14-inch models with a flattened screen. The September 1988 BYTE lists (in "Monitor Makers") contact information for the companies that manufacture such monitors.

I really like the output of gray-scale monitors, particularly the NEC Multi-sync GS (see "Review Update," September 1988 BYTE). The GS will accept TTL or analog video input and is compatible with a wide variety of video adapter cards. Our equipment did pick up excessive jitter, but the display is easier on the eyes than a no-frills TTL monochrome adapter and monitor. Not only is the gray-scale display visually appealing, but it adds functionality to programs that use color menus or extensive graphics. The monitor sells for under \$300.—S. A.

From VIC to PC

In 1983, V. J. Georgiou, Ph.D., published the VIC-20 *Interfacing Blue Book*. It contained information on programs and inexpensive hardware for connecting resistance and capacitance meters and a few other nice peripherals. The one I found most interesting was the digital thermometer. It used a 555 timer, a few resistors, capacitors, and a thermistor. The book included the wiring diagram and programs to operate the thermometer. Even the Radio Shack part numbers were included.

Well, my VIC-20 is gathering dust somewhere in my basement, but I would

continued



Now available preformatted
for MS-DOS, Versions 2.0 and higher.

Take the #1 diskette for a test drive.

Pass it around. BASF 5.25" diskettes have been independently rated #1 in performance in test after test. Error-free performance warranted for life accents the BASF commitment to technological leadership and business solutions. Call 800-343-4600 for details and the name of your nearest supplier.

Depend on it.



BASF

10 Diskettes
5.25" - 2S/2D

Two sided - Double density
Zweiseitig - Doppelte Dichte
Double face - Double densité
Certified 100% error free
Fehlerfrei - Sans erreur



BASF

Never buy another ribbon! with MacInker™

over 100,000 sold



Universal Cartridge MacInker \$68.50 **Imagewriter or Epson MacInker \$42.00**

Eliminate expensive fabric ribbon replacement with the famous MacInker. The Universal Cartridge MacInker (\$68.50) will re-ink most cartridges with the appropriate adapter. The Universal Spool MacInker will re-ink all spools. Operation is very simple & automatic. Our extra dark, lubricated ink yields better than new printout quality and its cooling effect extends print-head life. New ink dispenser ensures precise ink metering. Average number of re-inkings/cartridge is 60-100 at an average cost of 5 cents/re-inking. We also have dedicated MacInkers for special cartridges. All MacInkers, with appropriate Multicolor Adapter can re-ink multicolor cartridges (2 or 4 colors). Or use your MacInker to re-ink in 10 different colors: red, green, blue, yellow, purple, brown, orange, gold and silver. Our Customers range from individuals to Fortune 500 Corporations. In 1982 we pioneered re-inking technology and are dedicated to its development. We have a complete range of accessories, heat-transfer re-inking adapters, special inks and cartridges.

- Universal Cartridge MacInker68.50
- Multicolor Adaptor (specify printer)40.00
- Imagewriter I/II MacInker model 234 IM.....42.00
- Epson MacInker model 271EP42.00
- Universal Spool MacInker68.50
- Heat Transfer Adaptor40.00
- Extra Ink bottle3.00 pint18.50

All MacInkers delivered with bottle of ink, ink meter, reservoir, reservoir cover.. Black, uninked, colored, special cartridges available. Best ribbon quality at lowest costs.

Call for free catalog

Special Offer

Just say, "I saw it in 'Byte' and get a free mousepad with any order >\$60.00, or free key-beeper & flashlight combination for orders >\$100.00.

Buy the Universal Cartridge & the Universal Spool at the same time and get the second unit for \$50.00

New! FAX/MODEM, PC or MAC = the World at your fingertips



LightFax 9624 external **\$749.00**

It's a state of the art, high speed fax and a 2400 baud 100% Hayes™ compatible modem. **LightFax™ 9624** turns your PC into a powerful world communication machine at a lower cost than a standard fax. Powerful software offers sophisticated capabilities not found on standard fax machines, including document composition editing, file storage, name card data management, scheduled sending (when the phone rates are cheaper),

broadcasting (sending documents to multiple addresses), line queuing (sending multiple files), journal review of fax traffic and much more. **LightFax 9624** features **BACKGROUND OPERATION** (you don't have to quit your application to receive a fax). With optional **LightScan 200 dpi or 400 dpi scanners** you can scan your document into your computer, for fax transmission or for use with a paint program. Click the mouse and your LightFax 9624 becomes a 2400 baud modem, 100% Hayes™ compatible (Bell & CCIT). Overseas customers, please specify country to receive proper LightFax 9624 version and power supply.

- PC**
- LightSpeed 9624 external749.00
- LightSpeed 9624 internal699.00
- Windows™29.00
- Microsoft™ compat. mouse49.00
- 200 dpi Scanner199.00

- 400 dpi scanner (PC)273.00
- Macintosh**
- LightSpeed 9624 external749.00
- 200 dpi scanner MAC*499.00
- includes MAC interface
- Mac switch for scanner65.00

Satisfaction or 30 day refund on all products - Immediate shipment - Major credit cards

Computer Friends, Inc. Order Toll Free 1-800-547-3303

14250 NW Science Park Dr.
Portland OR 97229

in Oregon (503)626-2291
fax (503)643-5379 telex 4949559 CF

still like to run some time-versus-temperature programs. I currently own an IBM PC XT clone, and I seem to remember a "Blue Book" for the PCs, but I have been unable to find such a publication. I have even started to plow through some books on the 8088 processor, but nothing there seems to be leading me toward my thermistor circuit. I realize I could buy a \$300-to-\$1000 add-on system to read temperatures into data files, but I don't require that level of sophistication. Do you know of any publications that might help?

Wayne A. Holmes
Monroe, CT

I've found two references that should help you.

Interfacing Your Microcomputer to Virtually Anything by Joseph J. Carr (TAB Books, Blue Ridge Summit, PA: 1984) is not only a source of useful circuits, it's a good introduction to linear (analog) circuits.

Handbook of Software and Hardware Interfacing for IBM PCs by Jeffrey P. Royer (Prentice-Hall, Englewood Cliffs, NJ: 1987) should tell you how to put together your own interface boards for the PC and—most important—how programs can communicate with the interface.

—R. G.

A Problem Solved

Regarding Lee Rose's letter (January Ask BYTE), there is a very viable solution to his problem of running IBM PC AT and Apple programs on the same machine. An Apple IIe or IIGS with Applied Engineering's PC Transporter card will provide most of the compatibility he is looking for. This card is available in a 768K-byte (Apple mode)/640K-byte (IBM mode) configuration. The CPU is a high-performance 16-bit V-30 microprocessor operating at 7.16 MHz. An 8087-2 math coprocessor slot (with an 8-MHz clock rate) is included.

I have used this card on my IIGS for some time now, and I have found the product easy to use and 100 percent compatible with MS-DOS 3.3, GWBASIC, dBASE II Plus, WordPerfect, Framework II, and Microsoft Windows applications. Also, I have easily converted Macintosh files to the IIGS using a modem. This setup, while not as inexpensive as an IBM clone, offers medium-priced compatibility with all three major formats—hard to beat!

Dene R. Francis
Charleston, SC

Thanks for the information.—R. G. ■

IF YOU LIKED OUR AD, YOU'LL LOVE THE BOOK.

On the front gatefold of this magazine, you'll find a 4-page ad about our 386™ systems, 286 systems, laser printers, and low direct-from-the-manufacturer prices. And if you



like what you see, we have a 28-page catalog you'll like even more. Just send the card below, and we'll send you a free copy.

Or call (800) 426-5150. In Canada, call (800) 387-5752.

© 1988 DELL COMPUTER CORPORATION. 386 is a trademark of Intel Corporation.

GET OUR FREE 28-PAGE CATALOG OF DELL COMPUTER SYSTEMS.

This new catalog is the best place to shop for high performance 386 and 286 systems. We also offer a full line of software, peripherals, enhancement products, and networking solutions. Just send this card, and we'll send you a copy.

Name: _____

Title: _____

Company: _____

Address: _____

City: _____ State: _____ Zip: _____

Phone: _____

Please have a Dell representative call me.

- | | |
|---|---|
| 1. Are you a (select one): | 4. How many PCs do you have installed now? |
| A <input type="checkbox"/> End user | A <input type="checkbox"/> 1-10 |
| B <input type="checkbox"/> Consultant | B <input type="checkbox"/> 11-20 |
| C <input type="checkbox"/> Reseller | C <input type="checkbox"/> Over 21 |
| D <input type="checkbox"/> Corporate Purchaser | 5. How many PCs do you (your company) plan to purchase in the next twelve months? |
| E <input type="checkbox"/> DP/MIS Manager | A <input type="checkbox"/> 1-10 |
| 2. Which products are you most interested in? | B <input type="checkbox"/> 11-20 |
| A <input type="checkbox"/> 286 architecture | C <input type="checkbox"/> Over 21 |
| B <input type="checkbox"/> 386 architecture | 6. Is your requirement: |
| 3. Are you interested in computer products for: | A <input type="checkbox"/> Immediate |
| A <input type="checkbox"/> Home | B <input type="checkbox"/> 1-3 Months |
| B <input type="checkbox"/> Business | C <input type="checkbox"/> Over 3 Months |
| | D <input type="checkbox"/> Info only |

AD CODE 51ED9

GET OUR FREE 28-PAGE CATALOG OF DELL COMPUTER SYSTEMS.

This new catalog is the best place to shop for high performance 386 and 286 systems. We also offer a full line of software, peripherals, enhancement products, and networking solutions. Just send this card, and we'll send you a copy.

Name: _____

Title: _____

Company: _____

Address: _____

City: _____ State: _____ Zip: _____

Phone: _____

Please have a Dell representative call me.

- | | |
|---|---|
| 1. Are you a (select one): | 4. How many PCs do you have installed now? |
| A <input type="checkbox"/> End user | A <input type="checkbox"/> 1-10 |
| B <input type="checkbox"/> Consultant | B <input type="checkbox"/> 11-20 |
| C <input type="checkbox"/> Reseller | C <input type="checkbox"/> Over 21 |
| D <input type="checkbox"/> Corporate Purchaser | 5. How many PCs do you (your company) plan to purchase in the next twelve months? |
| E <input type="checkbox"/> DP/MIS Manager | A <input type="checkbox"/> 1-10 |
| 2. Which products are you most interested in? | B <input type="checkbox"/> 11-20 |
| A <input type="checkbox"/> 286 architecture | C <input type="checkbox"/> Over 21 |
| B <input type="checkbox"/> 386 architecture | 6. Is your requirement: |
| 3. Are you interested in computer products for: | A <input type="checkbox"/> Immediate |
| A <input type="checkbox"/> Home | B <input type="checkbox"/> 1-3 Months |
| B <input type="checkbox"/> Business | C <input type="checkbox"/> Over 3 Months |
| | D <input type="checkbox"/> Info only |

AD CODE 51ED9

IF YOU CAN'T CALL, WRITE.

On the front gatefold of this magazine, there's a 4-page ad for Dell Computer Systems. It invites you to call our toll-free number, so you

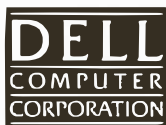

can get our free 28-page catalog. But if you'd rather send this card, that's fine with us. Just fill it out, and we'll get a catalog to you right away.

NO POSTAGE
NECESSARY
IF MAILED
IN THE
UNITED STATES



NO POSTAGE
NECESSARY
IF MAILED
IN THE
UNITED STATES



BUSINESS REPLY MAIL

FIRST CLASS MAIL PERMIT NO. 6745 AUSTIN, TEXAS

POSTAGE WILL BE PAID BY THE ADDRESSEE

DELL COMPUTER CORPORATION

Dept. ME

9505 Arboretum Boulevard

Austin, Texas 78759-9969



BUSINESS REPLY MAIL

FIRST CLASS MAIL PERMIT NO. 6745 AUSTIN, TEXAS

POSTAGE WILL BE PAID BY THE ADDRESSEE

DELL COMPUTER CORPORATION

Dept. ME

9505 Arboretum Boulevard

Austin, Texas 78759-9969



CHAOS MANOR MAIL

*Jerry Pournelle answers questions about his column
and related computer topics*

Don't Knock Unix

This letter is a rather long flame engendered by your comments on Unix, which are summarized, I believe, by the following quote from your September 1988 Computing at Chaos Manor:

"This whole situation puzzles me. I've had a dozen people try to explain why you can't simply fire up Unix and use it as the master operating system to run multiple DOS programs, and the usual answer is, 'You can, but nobody's done it.' None of them can answer the next question," which you asked in the previous paragraph and which follows.

"Of course, I can also run standard Unix programs, but why bother? All the Unix programs that do the things I want to do have been pretty small potatoes compared to what's available on DOS."

Your comments are arrogant and nonsensical, and as a result, your readers might be deprived of the opportunities afforded by Unix.

To answer your first question, try out the Sun Microsystems 386i. Multiple DOS tasks can be run effortlessly or optionally menu-driven in a Unix environment. The cost for the mind-boggling capabilities of the 386i is about what you would pay for one of the more familiar 80386 systems with comparable hardware, with or without Unix.

The answer to your next question, "Why bother?," is necessarily more personal. Like you, I have a single-user system, a lowly 80286. Like you, I write as part of my living. Unlike you, I run Unix and would not touch DOS. Why do we differ? I imagine because we want different functions from the computer. For example, when I write, I must have copious references that are absolutely accurate, inserted with text citation styles that differ widely between publishers.

Under Unix, it is easy to take references from a commercial database with any format and incorporate them into a paper with any citation style and any bibliographic style. The programs that you link together to do this are part of the standard Unix operating system or in the public domain.

Under DOS, there are commercial programs to handle reference database reformatting, citation insertion, and references. But they are indeed overpriced and not flexible enough to satisfy the bizarrely idiosyncratic requests of scientific publishers.

The widely used DOS word processing programs that you appear to favor, such as WordPerfect, have been or are announced as being ported to Unix. Perhaps the reason you haven't seen them is that the Unix user typically does not like them. But they are indeed available. As for myself, there's no way that I would ever return to WordStar, which I used from the late 1970s through the mid-1980s.

Unix is an extremely comfortable computing environment. As evidence, consider the number of people you know who have voluntarily shifted from Unix to DOS, compared with the number who have become Unix users. You can easily tailor Unix to your wants. The standard Unix tools are renowned for their power and variety.

You may not need a multiuser, multi-tasking system, but it sure is nice, even for a "single user" like myself. Not everyone has the same needs and preferences. But I imagine that among your readers there are also some, perhaps many, who have needs like mine or for other reasons would be better satisfied by Unix than by DOS. Give them correct information, and after that let them decide for themselves.

John Rupley
Tucson, AZ

Thank you for your kind words.

I am well aware that the Sun workstations can do wonderful things; indeed, I
continued

Jerry Pournelle holds a doctorate in psychology and is a science fiction writer who also earns a comfortable living writing about computers present and future. He can be reached c/o BYTE, One Phoenix Mill Lane, Peterborough, NH 03458, or on BIX as "jerryip."

NEW BLAISE TOOLS

*The fastest way to create
powerful programs
with Turbo Pascal
5.0 and Turbo C 2.0!*



Blaise Computing, manufacturer of function libraries that offer easy-to-use solutions to your programming needs, introduces:

POWER TOOLS PLUS/5.0—\$149

—completely integrated and lightning-fast routines to help you:

- ◆ Add moving bar pull-down menus and windows to your user interfaces; *NEW!* ◆ Generate context sensitive help screens; *NEW!* ◆ Add easy-to-use date and time conversion routines; *NEW!* ◆ Let users choose from window oriented pick lists; *NEW!* ◆ Create and access "huge" data structures; *NEW!* ◆ Use multiple-line edit fields with fully configurable edit keys; *NEW!* ◆ Speed up your sorting with flexible in-memory sort routines; *NEW!*
- ◆ Add EMS support; *NEW!* ◆ Write TSRs and ISRs easily;
 - ◆ Control DOS memory allocation;
 - ◆ Create powerful programs in Turbo Pascal 4.0 & 5.0!

Turbo C TOOLS/2.0—\$149

—tight, fast, high quality functions to help you:

- ◆ Add easy-to-use mouse support for windows and menus; *NEW!*
 - ◆ Quickly include virtual windows and menus; *NEW!*
 - ◆ Integrate your windows and menus with Turbo C's text windows; *NEW!* ◆ Create context-sensitive help screens; *NEW!*
 - ◆ Provide multiple-line edit fields with fully configurable edit keys; *NEW!* ◆ Use keyboard and video services (including enhanced keyboard and VGA); *NEW!*
- ◆ Write TSRs and ISRs easily; ◆ Create powerful programs in Turbo C 1.0, 1.5 and 2.0!

FREE with these products!

Source code, complete sample programs, a comprehensive reference manual with extensive examples, the Norton Guides Instant Access Program, and an online database. We also offer free technical support and a bulletin board system dedicated to technical issues.

Unleash your programming potential!

Blaise Computing offers programming tools that are fast, flexible and affordable. Call now to order or to ask for a free brochure on our full line of products for C and Pascal.

Put Blaise tools to the test!

If at any time during the first 30 days you are not completely satisfied with their speed and flexibility, we'll refund your money.

Call 800-333-8087 today!

BLAISE COMPUTING INC.
2560 Ninth St., Suite 316, Berkeley, CA 94710, (415) 540-5441
FAX: 415-540-1938

Turbo C and Turbo Pascal are trademarks of Borland International.



THINK BIG

Phar Lap Virtual Memory Manager.

It will let you write applications up to 5, 10, 15 megabytes or more for any 386 PC running MS-DOS*. *Forget about RAM limitations.* Your application can run on a machine with as little as 1 or 2 megabytes of memory.

Only Phar Lap 386IVMM* gives you demand-paged virtual memory capability so you can write mainframe-sized applications for the PC. Applications your customers can run on their 386 PCs now with no additional memory. No kidding. All you need is 386IVMM and our family of 386 development tools. Existing programs developed with our 386IDOS-Extender can be easily expanded with 386IVMM too.

Our tools let you take full advantage of the 386 protected mode architecture. Break the DOS 640K limit in the language of your choice; C, Fortran, Pascal, or Assembler.

For fast compact code, use 386IASM, our 80386 assembler that's upwardly compatible with the MASM* 8086 assembler. Existing DOS and mainframe applications written in a high level language are easily ported by recompiling. And 386LINK, our 32-bit native mode linker, puts it all together.

Debugging is made easy too. With our 386 symbolic debugger you can debug applications written in assembler or any high level language. Best of all, with Phar Lap's 386IDOS-Extender* you can run your native mode program on any 386-based PC running MS-DOS. And you have full access to DOS system services through INT 21.

NO COMPATIBILITY PROBLEMS

Phar Lap's tools are compatible with the industry's leading systems: DESKPRO 386*, IBM Model 70/80*, 386 clones and accelerator boards. Not only will your new applications be compatible with the leading systems, they'll run alongside all other DOS applications.

- \$495 386IASM/LINK-Package includes 386 assembler, linker, MINIBUG debugger and the developer version of 386IDOS-Extender
- \$895 MetaWare 80386 High C* compiler
- \$595 MicroWay NDP Fortran-386* compiler
- \$195 386IDEBUG symbolic debugger
- \$295 386IVMM - developer version of the Phar Lap Virtual Memory Manager

NO ROYALTY PAYMENTS

Once your 386 application is complete, all you pay is a low one-time fee to license 386IDOS-Extender for redistribution.

386IVMM is also developer friendly. Call to find out about our flexible run-time pricing.

You can unlock the entire DOS market now. Don't wait for OS/3.

(617) 661-1510

PHAR LAP SOFTWARE, INC.

60 Aberdeen Avenue, Cambridge, MA 02138

Fax: (617) 876-2972

"THE 80386 SOFTWARE EXPERTS"



Phar Lap and 386IDOS-Extender and 386IVMM are trademarks of Phar Lap Software, Inc. MS-DOS and MASM are registered trademarks of Microsoft Corp. DESKPRO 386 is a trademark of Compaq Corp. NDP Fortran-386 is a trademark of MicroWay, Inc. High C and Professional Pascal are trademarks of MetaWare Incorporated. IBM Model 70/80 is a trademark of IBM Corp.

think I wrote at length about some of the work one of my friends did at Bellevue Hospital using a Sun. However, I haven't tried a Sun386i myself because I don't have one and because, up to now, those big Sun workstations have been well beyond the financial limits I generally impose on equipment I'll write about. I don't write about VAXes for the same reason.

Your statements about the 386i with Unix being about what you'd pay for "one of the more familiar 80386 systems with comparable hardware" is true only in the sense that you can load up anything. My Big Cheetah with everything aboard has a list price of only about \$10,000. If I added Unix software, which is very expensive, that price would certainly rise.

Finally, your letter is typical of those I get. "Unix is wonderful, and I'm using it right now, and I can do all these terrific things." Fine, say I, and I invite Unix experts to come over here and set something up on one of my machines—and I have a lot of them.

The result so far has been a lot of good excuses. I have nothing against Unix, but I will not change my rules, which are that I write about what I'm using and that what I use has to work on equipment here at Chaos Manor and get done the jobs I have to do, such as writing books and columns and doing my taxes.

I'm glad you're happy with your system and that you like to grep and urk.

—Jerry

Exploit the Space Bar

Dear Jerry,

Recently, you've been trying to get us to use better keyboards. I have long wondered why designers haven't made better use of the space bar.

When there are 100 keys on a board for eight fingers, why is there one bar for two thumbs? In the search for more functions, why can't the bar be split in two—the right half for the right thumb, the left for the left thumb?

I'm all thumbs, but I bet I could train my right thumb to strike the right bar to move the cursor forward and my left thumb to strike the left bar to backspace.

Please put this suggestion in the public domain before someone claims "look and feel."

James T. Oitzinger
Houston, TX

That sounds like an interesting idea. I've been watching, and I hardly ever use my left thumb for anything. Fascinating. Thanks for the suggestion. —Jerry ■

Choosing the Right Database Development System Just Got Easier.

db_VISTA III™ Delivers High Performance With No Hidden Costs.

For database applications development, you want a system with performance, portability, and full functionality at a competitive price. But there's more to it than that. The long term costs associated with extended development schedules, frequent maintenance, excessive royalties, or the inability to handle complex data relationships are often overlooked. These hidden costs can be quite a shock after you have made a commitment and are midway through application development, or worse yet, in production.

With db_VISTA III from Raima, there are no surprises. It provides powerful database capability with tremendous overall cost savings. The heart of the system is db_VISTA, a high performance DBMS that uses B-tree indexing and the network database model file structure to minimize overhead and provide fast data access. Our SQL-based db_QUERY provides a relational view of the network structure, without sacrificing performance. And db_REVERSE lets you easily redesign your database. The entire db_VISTA III system is fault tolerant and complete source code is available.

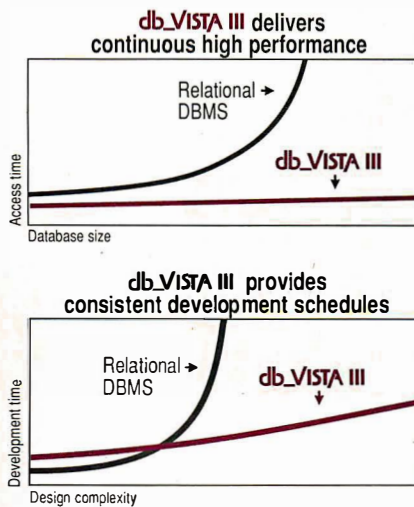

db_VISTA: High Performance DBMS
Multi-user
Fast data access: B-tree indexing, network database model, virtual memory disk caching
Multiple Database Access
Referential integrity
Automatic recovery
Record and file locking
Database consistency check
Easy-to-use interactive access programs
Data Definition Language patterned after C

db_QUERY: SQL-based Query
Relational interface to db_VISTA databases
Yields extraordinary performance
Build ad hoc queries & reports

db_REVERSE: Database Restructure Program
Redesign your database
Converts existing data to revised design
Upgrade remote end user locations easily

Add WKS Library for Lotus 1-2-3
Fast C interface to Lotus, dBASE and others

Operating Systems: VMS, ULTRIX, UNIX System V, BSD 4.2, SunOS, QNX, XENIX, OS/2, MSDOS, Macintosh, MS Windows

C Compilers: VAX, UNIX, XENIX, SunOS, Microsoft, Lattice, TurboC, LightspeedC, MPW

LANs: NFS, 3Com, NetWare, LifeNet, Banyan, and any other MS-DOS NetBIOS-compatible LAN. AppleShare and network-independent versions also.

Thousands of C programmers in over 50 countries worldwide have chosen Raima's db_VISTA III. Here are the reasons why:

- Fast data access
- Minimal data redundancy
- C source code available
- Automatic recovery
- Multi-user support
- Portable to VMS, UNIX, OS/2, MS-DOS and Macintosh
- SQL-based relational query
- No royalties
- Professional services
- Superior support

Now Supports
Microsoft
Windows

Maybe it's time that you checked out db_VISTA III. Consider *all* the costs. It could be the easiest choice you ever made.

CALL:

1-800-db-RAIMA
(that's 1-800-327-2462)

Ask about the many other products and services Raima Corporation offers, including consulting, application development, and training.

RAIMA™ CORPORATION BY49

✓ Fast Access
✓ Portable
✓ No Royalties
✓ Reliable Tech Support
✓ Clear Documentation
✓ Auto Recovery
✓ SQL
✓ Source Code
✓ C Language
✓ VAX/UNIX

Some views on why the NEC MultiSync

There's a lot more to the new MultiSync® 3D monitor from NEC than meets the eye. Because instead of making one monitor for each

graphics board, we've developed a monitor that enhances



the performance of the modes on practically any board.

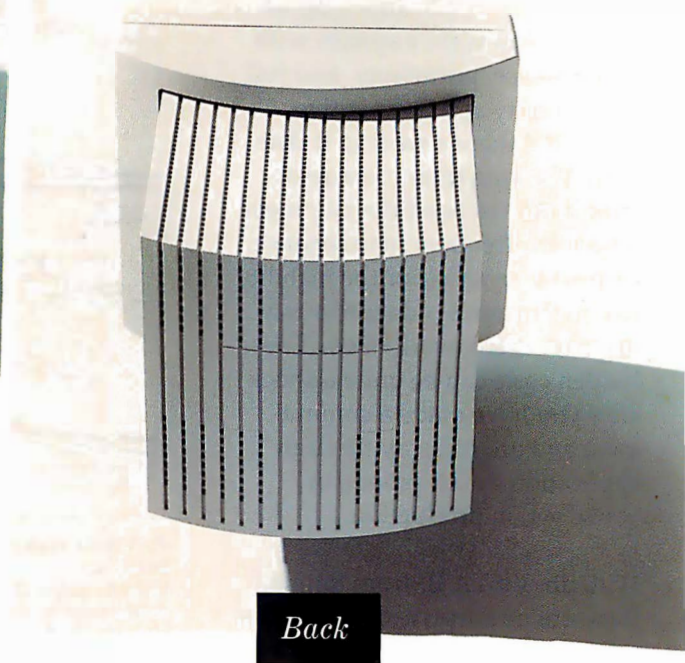

With its new microprocessor-controlled digital tuning system, MultiSync 3D can adjust to a given video standard with a precision matched only by a few high-end single-frequency monitors.

Making it perfectly compatible with virtually all systems and boards. From 8514A, SuperVGA and Mac II to VGA, EGA, MDA and

3D is the new monitor standard.

CGA. For an incredible maximum resolution of 1024 x 768.

What's more, MultiSync 3D is equally compatible with you and your workplace. There are upfront controls, for easier access. A 14" non-glare screen on a tilt-swivel base, for more comfortable viewing. And, as you can see, there's even a full 360 degree design.

The way we see it, MultiSync 3D

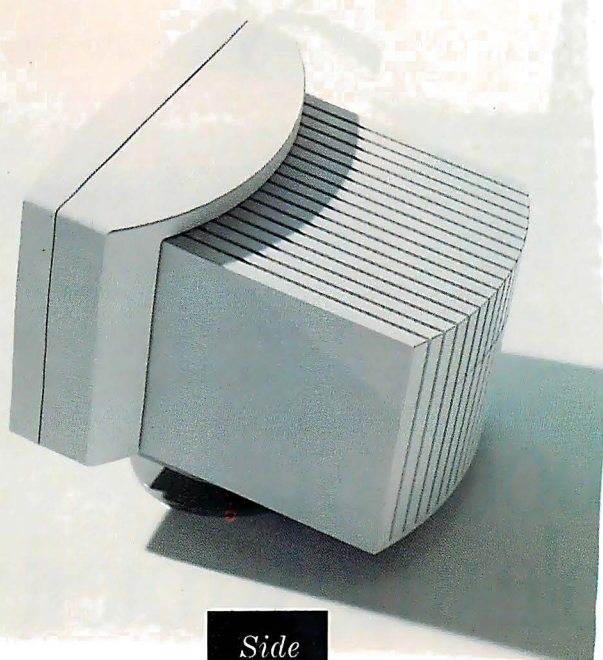

Side

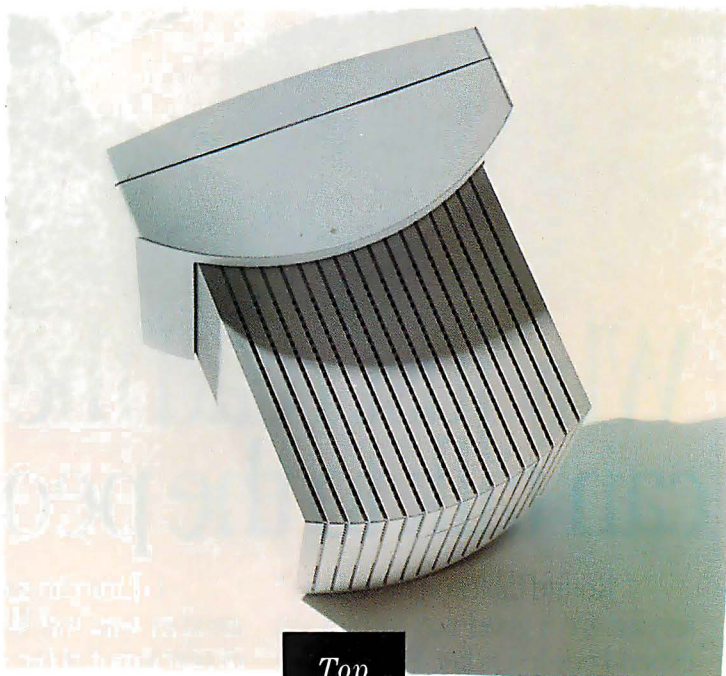

Top

has dramatically raised the

standards by which all other color monitors will be judged.

MultiSync is a registered trademark of NEC Home Electronics (USA) Inc.

For literature, call 1-800-826-2255. For technical details call NEC

Mac II is a registered trademark of Apple Computer, Inc.

Home Electronics (USA) Inc. 1-800-FONE-NEC.

©1989 NEC Home Electronics (USA) Inc.

NEC

APRIL 1989 • BYTE 49

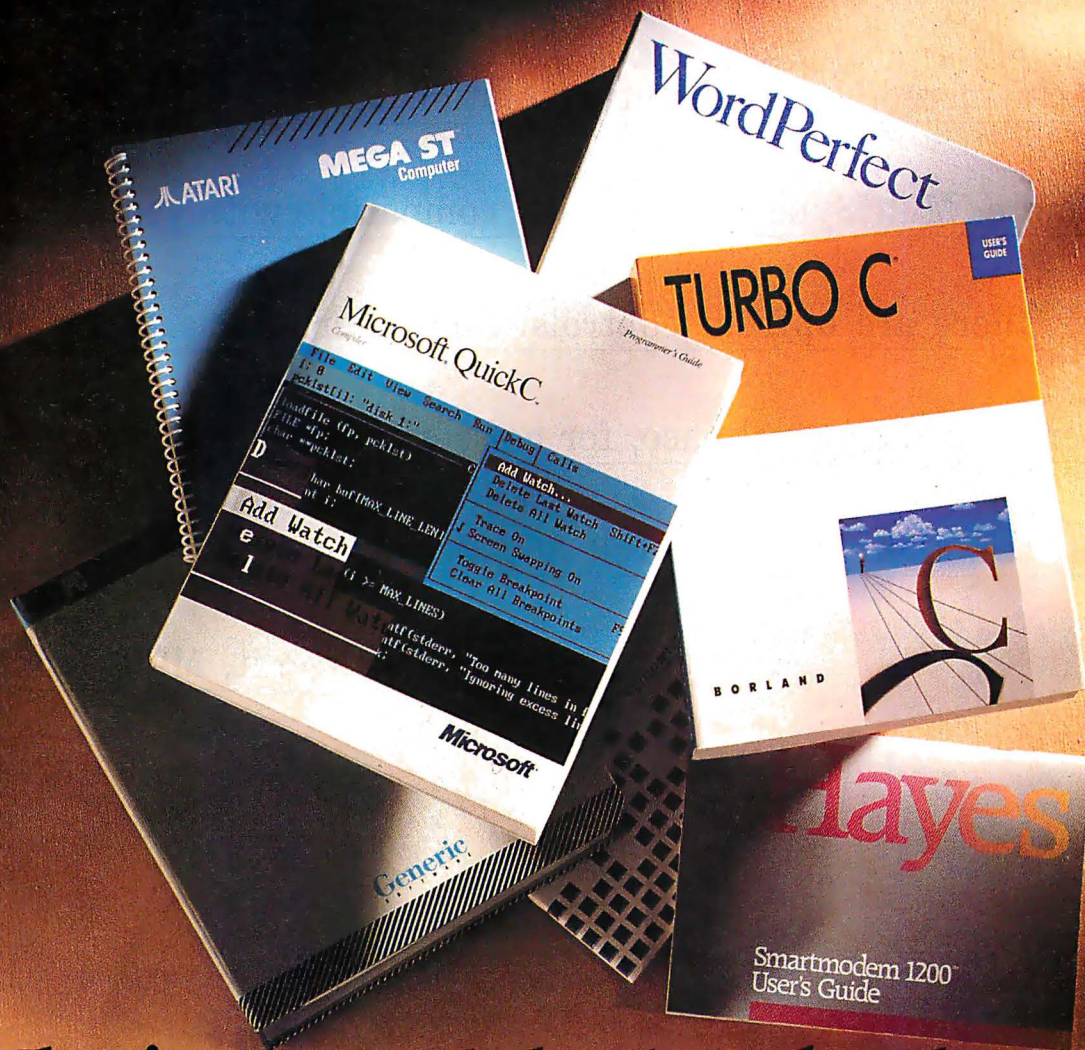

Why just read the book when you can talk to the people who wrote it?

RoundTables on the GENie™ service are a good way to pick up expert knowledge fast. Because they're the best way to talk to experts at the leading companies. People like Apple's Jean-Louis Gasse, Tandy's Ed Juge and Atari's Sam Tramiel are frequent guests. Providing in-depth answers and updates that can save you time as well as money.

GENie can save you money another way, too. We bring you expert input at the very best rate. Just \$5 an hour*. So you can stay online longer for a whole lot less.

And with GENie signing up is as easy as one, two, three. (1) Set your modem for local echo (half duplex), either 300 or 1200 baud. (2) Dial 1-800-638-8369. When connected, enter HHH. (3) At the

U#=#prompt enter XJM11700, GENie then RETURN. And have a major credit card or your checking account number ready. For more information in the United States or Canada, call 1-800-638-9636.



We bring good things to life.

*Applies only in U.S. Mon.-Fri. 6PM-8AM local time and all day Sat., Sun., and most holidays. Subject to service availability. Some services may include additional charges.

BOOK REVIEWS

Mind Children: The Future of Robot and Human Intelligence

by Hans Moravec

Harvard University Press,
Cambridge, MA: 1988,
186 pages, \$18.95

Reviewed by Eric Robinsky

Although Marvin Minsky was using the phrase “meat machine” in the early 1960s to describe the human brain, this mechanistic viewpoint dates back to the industrial revolution and perhaps much earlier. For years, science fiction writers have constructed worlds in which robots equaled and even improved on human intelligence.

The idea that we humans will eventually build super-intelligent machines that might replace us is hardly new, yet the AI community, which used to confidently proclaim it, has lately retreated to a much more conservative stance. After all, it is difficult to extrapolate the superhuman potential of our machines when, after 30 years of AI research, some of the simplest tasks performed by the “meat machine” cannot even be approached by our most advanced creations.

Thus, it is somewhat surprising when the director of Carnegie-Mellon University's Mobile Robot Laboratory writes a book on AI and robotics that stretches the limits of imagination. Hans Moravec's *Mind Children: The Future of Robot and Human Intelligence* goes far beyond the science fiction writers' view of superhuman robot intelligence and, without apology, dogmatically presents the author's ideas on the evolution of human and

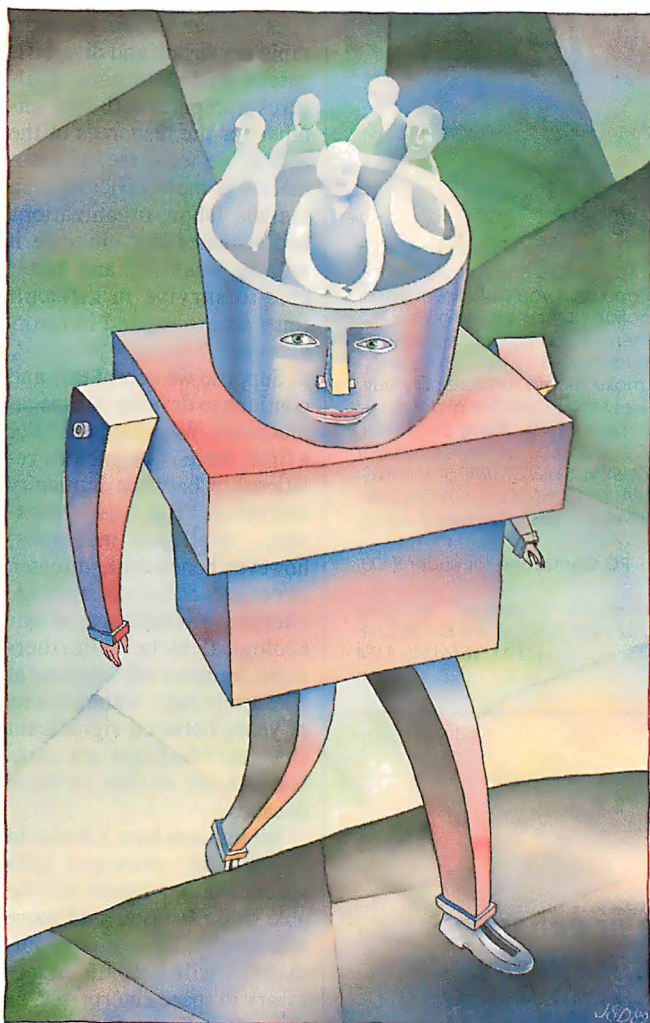

machine intelligence. It is one of the most fascinating books on the subject ever written.

Mind Children is the kind of book that makes readers react. They will argue with at least some of the author's ideas (I argued with quite a few). But that's not surprising, given the book's main premise that the biological evolution of humanity is complete, that the future will consist of a postbiological world dominated by our robots, and that we will eventually transfer our own minds directly into the machines we

build. When speaking of current robot technology, Moravec writes that he sees “the beginnings of awareness in the minds of our machines—an awareness that I believe will evolve into consciousness comparable with that of humans.”

Transferring our consciousnesses into the minds of robots is an idea that might be safely relegated to the distant future—but coupled with it is the author's unequivocal statement that computers will have attained the processing power

of the human brain within 40 years, which Moravec justifies by extrapolating from the rate of development of digital hardware since the time of Charles Babbage. So we aren't necessarily looking as far into the future as might allow us to comfortably contemplate this potential loss of human identity—perhaps only a few thousand years or less.

But creating a 10-teraops processor—which Moravec calls a “human equivalent computer”—isn't the ultimate goal. He goes on to discuss the possibility of protein robots that are genetically engineered to assemble circuits at the nanometer scale, allowing the creation of artificial brains millions of times more powerful than the human mind. Robots equipped with these brains might in turn be capable of using the ultradense matter of neutron stars to create processors that are one million million million million million times more powerful than the human brain by sidestepping certain currently accepted physical limits on the switching speeds of microcircuitry.

After taking the reader on a brief tour of theoretical physics and having tried to establish the feasibility of such ultrapowerful robot brains, Moravec moves into the realm of psychobiology. How will we be able to coexist with fellow creatures—for that is what our robots will become—that are clearly far superior to us in every respect? And, if that doesn't seem possible, should we even continue trying to develop them? What are the justifications for engineering our own obsolescence? Moravec writes, “The answer, I believe, is that we have very little choice, if our culture is to remain viable. Societies and

continued

ALSO REVIEWED

The Dreams of Reason: The Computer and the Rise of the Sciences of Complexity

"TURN MY PC INTO A PROTOCOL ANALYZER FOR UNDER \$400? ...SHOW ME!"



If you're involved in data communications, the PC Comscope can give you data line monitor capabilities at a fraction of the cost using your PC. Making use of pull down menu's and built-in help screens provides true operator simplicity. The combination of these features and price make this an extraordinary buy. You can view the bidirectional data and control signals of any RS-232 link. The PC Comscope capabilities include:
ASYNC; SYNC; HDLC; TIME STAMPING;
SOPHISTICATED TRAPPING; STORE DATA ON DISK;
ASCII; EBCDIC; IPARS... Telebyte does it again!

PC Comscope for under \$400.

TALK TO **TELEBYTE** 270 E. Pulaski Rd. Greenlawn, NY 11740
(516) 423-3232 / 385-8080 or 1-800-835-3298
FAX: (516) 385-8184

**Introducing the
WINDOWS environment
for the dBASE language!**

Create or enhance dBASE applications under Microsoft Windows!

\$249
Suggested Retail Price

\$199
Introductory Price
with this ad
30 day money back guarantee!

dBFast/Windows is a complete dBASE language development environment running under MS-Windows. Using familiar dBASE syntax you can create applications with multiple, moveable windows, pull-down menus, checkboxes, bit map pictures and much more! You can even port existing dBASE and Clipper applications. dBFast/Windows features an interactive editor, compiler, royalty free runtime system, DDE support and portability to the Macintosh using dBFast/MAC. Call or write for more details.

Bumblebee Software, Inc.
1715 114th Ave. SE - Woodridge Bldg. #120
Bellevue, Washington 98004 USA
Tel: (206) 462-0130 Fax: (206) 454-3577

economies are surely as subject to competitive evolutionary pressures as biological organisms. Sooner or later, the ones that can sustain the most rapid expansion and diversification will dominate. Cultures compete with one another for the resources of the accessible universe. If automation is more efficient than manual labor, organizations and societies that embrace it will be wealthier and better able to survive in difficult times and to expand in favorable ones."

Suppose we accept this and continue to develop our megamachines. What happens? For a time, there is a symbiotic relationship between humanity and robot. "But," says Moravec, "intelligent machines, however benevolent, threaten our existence because they are alternative inhabitants of our ecological niche." Furthermore, humankind "evolved at a leisurely rate, with millions of years between significant changes. Machines are making similar strides in mere decades."

We humans have a desire to expand our presence into space. But our robots will be able to do it faster and more effectively. "Eventually humans... will become unnecessary in space enterprises, as the scientific and technical discoveries of self-reproducing superintelligent mechanisms are applied to making themselves smarter still. These new creations, looking quite unlike the machines we know, will explode into the universe, leaving us behind in a cloud of dust."

The matter doesn't end there. Humans have a propensity for trying to better themselves, and what better way to do that than to have the mind transferred into a far superior, immortal robot body? We are immediately confronted with the mind-body problem of philosophy: Is the me in the new body really the old me? Or is it a perfect copy of the old me—and does it really matter? Two sections, "What Am I?" and

"Awakening the Past," delve deeply into the problem.

Are there demons in this paradise of immortality and superintellect? "If the world of artificial machinery has seemed disease-free so far, it is only because our machines have been too simple to support mechanical parasites," writes Moravec in a section called "Trojan Horses, Time Bombs, and Viruses." In these pages (which are particularly interesting to read in light of the recent invasion of a nationwide Unix network by a computer science student's program), the author explores various types of digital fauna that can be made to infect and damage computer systems.

If robots can be made as complex as Moravec maintains, then we can easily imagine how susceptible they would be to equally complex parasitic programming. Furthermore, if we ourselves inhabit the robots, then the virus analogy becomes even more apropos. Here we have an entire system of artificial life-forms: robots, human-robots, and the parasites infecting them—a concept Moravec calls "freely evolving digital wildlife." Parasitism, far from being undesirable, is necessary for triggering the mutations that will allow this system to continue to evolve. In other words, the transition from biological system to post-biological system is complete and irreversible.

Thus, we have built machines that are our postbiological successors. We have looked upon them and seen that they are good. And we have finally abandoned our bodies and moved to inhabit our machines. This has taken many years, but maybe not as long as we anticipated. We have had ample time to thoroughly explore our own universe, and probably others as well. But the universe must ultimately wind down—a victim of entropy death, tragically cutting short our reign of intellect. But not to worry—we are

continued

Produce Programs in a Flash

With Smalltalk-80, the Best in Object-Oriented Technology.

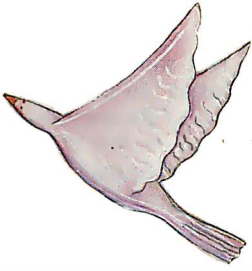

It's amazing.

In just a few years, object-oriented technology has become an overwhelming favorite. Witness the success of graphical user interfaces. But what's the best environment for developing these object-oriented programs?

Fortunately, that's no mystery. It's the Smalltalk-80™ program development environment from ParcPlace Systems. Pioneers of object-oriented technology.

We deliver the most complete, fully-integrated system available, with everything you need to quickly and easily develop and implement programs. Including a library of reusable code modules. Browsers, inspectors, and debuggers. Text and graphics editors. Online assistance. Dynamic cross referencing. And much more.

In fact, Smalltalk-80 is so comprehensive, Byte Magazine (1/89) felt compelled to rave, it "... includes everything you need for program development. Everything. And all the goodies are honest-to-God fully integrated."

Even better, Smalltalk-80 gives you true portability. Write programs on a UNIX® workstation and deliver them directly on DOS and MAC OS machines. Or vice versa.

To make sure you start fast and stay productive, we provide the best tech support in the business. Including training, documentation, a hotline, and more.

For details on Smalltalk-80, write:

ParcPlace Systems
1550 Plymouth Street
Mountain View, CA 94043

Call 1-800-822-7880, ext. 20; in California, 415-859-1000, ext. 20. Or use E-Mail. Our address: info@parcplace.com.

When you see what it can do, you won't believe your eyes.



ParcPlace

Smalltalk-80 is a trademark of ParcPlace Systems, Inc. UNIX is a registered trademark of AT&T. © 1989, ParcPlace Systems, Inc.

Circle 210 on Reader Service Card

APRIL 1989 • BYTE 53

98.9% Radiation and 100% Static Free Working Environment

1989 Brand-New Design & Price

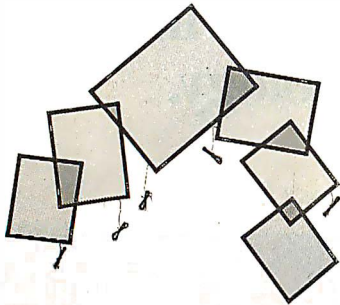

RCS 581 YDT Filter

- 98.9% radiation and 100% static free level
- Eliminates glare and reflection.
- Flexible frame fitted on curvy and flat monitors.
- Effective on both color and mono VDT's.
- Fider also useful for TV watchers.

RCS 587 Anti-Radiation Apron

- Avoid radiation of micro wave oven
- Prevent from radiation of computer

RCS 583 Anti-Static Keyboard Strip

- Offers full static protection to computers.
- Made of highly conductive fibers.
- Includes a 3-meter grounding cord.
- Doubles computer's lifespan.

RCS 582 Anti-Static Computer Cover

RCS 588 Anti-Static Car Seat Cover

RCS 590 Anti-Static Fabric

RCS 593 Anti-Static Steering Wheel Cover

See us at:



Distributor Welcome



RCS

RCS TECHNOLOGY CORPORATION

12F., No. 148, Sung Chang Rd., Taipei, Fax: 886-2-5363696
Taiwan, R.O.C. Tel: 886-2-5512614 Telex: 28902 RCSTEC

The first manufacturer of Floppy Diskette in Taiwan

Our automatic production lines prevent diskette from manual operation error. Every diskette is certified by Media Logic's certifier.

We offer:

- 100% error-free
- lifetime warranty
- colour diskettes
- in-stock inventory in Seattle/Washington
- formatting & duplicating service

Please contact us now!

U.S.A. sales office:
FIT-TECH IND. INC.
2101 R Street N.W.
Auburn, WA 98001
TEL: (206) 833-9157
FAX: (206) 833-9290



REP/DEALER WANTED



Factory:

LEE YUAN CO.

5 Fl., No. 45 Chi Lin Road
Taipei, Taiwan
TEL: (886) 2-5612191
FAX: (886) 2-5363405
TLX: 22553 ASURCO

BOOK REVIEWS

now even capable of forestalling the end of the universe by storing energy and releasing it at the proper moment. So our robots, which may be ourselves, have finally attained the stature of gods. But they have done so through what Moravec depicts as a necessary and logical progression in the evolution of the human brain, so perhaps the concept isn't as far out as it seems.

Mind Children is destined to be a controversial book. The margins on every other page of my copy are covered with question marks and exclamation points; it is impossible to read the book and be impartial. It has the accuracy of a college text and the can't-put-it-down appeal of a good novel. Moravec has turned the flights of mind of one of the world's foremost roboticists into hard copy. And he has written a tremendously good book in the process.

spective that would prevent such confusion. In his book *The Dreams of Reason: The Computer and the Rise of the Sciences of Complexity*, he explores how, through computers, we are acquiring the insights required to reverse the tide of cultural entropy and find order in what was previously perceived as chaos. Pagels uses the term "complexity" to describe recent and startling developments in the sciences that have the potential to displace earlier scientific models. These developments are largely a result of the advent of the computer as an instrument of inquiry, and they also display an amazing similarity to the workings of nature itself.

Pagels, who died last year, was executive director of the New York Academy of Sciences and a physicist at Rockefeller University. In *The Dreams of Reason* he thoughtfully explores some of the new "sciences of complexity": chaos theory, computational biology, computer simulation, neural networks, and the increasingly complex web of financial computer networks. He goes on to a thorough and detailed consideration of the philosophical and cultural implications of a scientific paradigm of complexity.

The term "complexity" is itself the first complex concept of the book, because it has numerous meanings and implications and simply cannot be tied down to any one. Pagels's loose definition is that complexity lies between order and chaos. On one hand, a crystal, with its regular rows of atoms, is "ordered" and can be easily known or determined. Completely chaotic systems like gases, on the other hand, can be well understood because "we can apply the laws of statistics to them with great effect."

Complexity could be said to lie between determinism and statistics, a difficult and shady region without clear boundaries. One measure of the

The Dreams of Reason: The Computer and the Rise of the Sciences of Complexity

by Heinz Pagels

Simon and Schuster, New York: 1988, 352 pages, \$18.95

Reviewed by David A. Mindell

Computers are symbolic machines. So stunning is their appetite for symbolic manipulation, however, that what we used to think of as the "meaning" behind our signals is often obscured by the proliferation and seeming self-replication of machine codes. From bar code to source code, from ISDNs to ICBMs, our culture seems headed for a digital meltdown. Antiquated modes of thought may soon be unable to extract signals from the parasitic noise of the once-hailed Information Society.

Heinz Pagels presents a per-

continued

Discover Parallel Processing!



Monoputer/2™

*The World's Most Popular
Transputer Development System*

Since 1986, the MicroWay **Monoputer** has become the favorite transputer development system, with thousands in use worldwide. Monoputer/2 extends the original design from 2 to 16 megabytes and adds an enhanced DMA powered interface. The board can be used to develop code for transputer networks or can be linked with other Monoputers or Quadputers to build a transputer network. It can be powered by the 20 MHz T414 or T800 or the new 25 MHz T425 or T800.

Parallel Languages

Fortran and C Make Porting a Snap!

Microway stocks parallel languages from 3L, Logical Systems and Inmos. These include one Fortran, two Cs, Occam, Pascal, and our own Prolog. We also stock the NAG libraries for the T800 and Rockfield's structural and thermal finite element package. A single T800 node costs \$2,000, yet has the power of a \$10,000 386/1167 system. Isn't it time you considered porting your Fortran or C application to the transputer?

Quadputer™

*Mainframe Power
For Your PC!*

MicroWay's **Quadputer** is the most versatile multiple transputer board on the market today. Each processor can have 1, 4 or 8 megabytes of local memory. In addition, two or more Quadputers can be linked together with ribbon cables to build large systems. One MicroWay customer reduced an 8 hour mainframe analysis to 15 minutes with five Quadputers, giving him realtime control of his business.

For further information, please call MicroWay's Technical Support staff at (508) 746-7341.

Micro Way

World Leader in PC Numerics

P.O. Box 79, Kingston, MA 02364 USA (508) 746-7341
32 High St., Kingston-Upon-Thames, U.K., 01-541-5466
USA FAX 617-934-2414 Australia 02-439-8400 Germany 069-75-1428

Dazzling Performance.



286/SS

Complete 12MHz '286
with 32MB Hard Drive!
Only \$1395.00

It's the fastest '286-12 you can buy. Workhorse of the industry. Rugged from the ground up. This true Zero-Wait state system features a fast Seagate auto-park hard drive. Nothing can touch it!

- 80286-12 CPU, 6/12MHz Dual Speed keyboard/hardware selectable. Reset and Turbo buttons right up front.
- Zero-Wait State DRAM, 512K expandable to 4MB on the motherboard (16MB System Total). EMS capability!
- Fast 32MB Seagate I38R Hard Drive with auto-park, 1.2MB Floppy Drive.
- Ultra high speed Hard/Floppy controller. 1:1 interleave, 800 KB/sec transfer rate.
- High-Res Amber Display, Tilt/Swivel Base.
- ZEOS Enhanced 101 Key Keyboard, with Pleasant Tactile/Click Feel.
- Serial and Parallel Printer Ports.
- Clock/Calendar with Battery Backup.
- 6-16 and 2-8 bit expansion slots.
- 80287 support, up to 12MHz.
- Heavy Duty Case complete with Security Lock and LED indicators.

20MHz '286 HARD DRIVE SYSTEM

286/20—At 20MHz, the fastest '286. Complete with our 32MB, 33ms Hard Drive and 1MB RAM. This is what Dazzling Speed is all about. Only \$2095.00

If you're buying a new computer, ZEOS® is your best choice. Why? Because ZEOS custom builds the best computers money can buy and sells them *factory direct* to you. *PC Resource Magazine* put it this way, "ZEOS...provides quality comparable with the IBM or Compaq and does so for about 70% of the cost"

And a recent review in *PC Magazine* said "comparing the ZEOS with a typical clone is a bit like comparing the Space Shuttle Booster rocket with a helicopter rotor... If you're looking for one of the fastest rides around at a down-to-earth price, don't pass up the ZEOS. Solid construction, flexible design and escape-velocity performance make it a top flight choice."

We couldn't have said it better ourselves.

That's why ZEOS is fast becoming the *preferred choice* of corporate, government and institutional buyers around the world. That's why it's the best choice for you.

So pick out your dream machine and order it now with confidence. Dazzling performance and incredible prices await you. *Guaranteed.* Order now by calling 800-423-5891.

YOUR BEST CHOICE!

We don't just say it. We guarantee it. Your new ZEOS system comes with a Full One Year Limited Warranty and our 30 day Full Refund Satisfaction Guarantee. Fully Compatible and Rock Solid. Your best choice without question.

Incredible Prices.

Options Galore. As *PC Magazine* said, "more options than even the most configuration-hungry-hound could possibly need!" Including 14" EGA, add \$495. 14" VGA, add only \$695. An incredible selection of hard drives and virtually any other add-on you could want. Call now Toll Free for details 800-423-5891.

All prices and specifications are subject to change without notice. Please call for current pricing and warranty details. ZEOS is a publicly traded company, MPLS/St. Paul Local OTC. ©1989 ZEOS International, Ltd., 530 5th Avenue, N.W. St. Paul, MN 55112



'386SX

The New ZEOS 386SX Hard Drive System. Below '286 Prices!
Only \$1895.00

The future is now!

PC Magazine says "386SX-based machines are the right choice..." the new ZEOS 386SX is why. The future is yours now with the new ZEOS '386SX. It's even priced below comparable '286 systems!

- 80386SX-16 CPU, 8/16MHz Dual Speed Keyboard Selectable. Reset/Turbo buttons.
- Zero-Wait State DRAM, 512K expandable to 4MB on board (16 MB System Total).
- Shadow RAM and EMS capability.
- Fast 32MB Seagate 138R Hard Drive, 1.2MB FDD
- Ultra high speed Hard/Floppy controller. 1:1 interleave, 800 KB/second transfer rate.
- High-Res Amber Display, Tilt/Swivel Base, compatible graphics controller.
- ZEOS Enhanced Tactile/Click keyboard.
- High Speed Serial and Parallel ports.
- 6-16, 2-8 bit expansion slots. 80387SX Math coprocessor support.
- ZEOS space saver case. Including Security Lock and LED indicators.



'386DT

Complete ZEOS 20MHz '386 Desktop System. 65 MB Drive!
Only \$2995.00

16 MHz systems also available!



The new '386 desktop standard. Featuring our 64K CACHE (twice that of most competitors) providing Zero-Wait State performance vastly superior to page/interleave memory schemes. Incredible value.

- High speed Zero-Wait 64K SRAM CACHE.
- Genuine 32-bit Intel 80386-20MHz CPU.
- 1MB of Zero-Wait DRAM Expandable to 16MB System Total.
- Fast 65MB Seagate Hard Drive, 1.2MB Floppy Drive.
- Ultra high speed Hard/Floppy controller, 1:1 interleave, 800 KB/sec transfer rate.
- High-Res Amber Display with Tilt/Swivel Base, compatible graphics controller.
- 101 Key ZEOS Tactile/Click keyboard.
- High speed Serial and Parallel Ports.
- 1-32, 5-16 and 2-8 bit slots.
- 80387 math coprocessor support.
- ZEOS 5-bay case. Including Security Lock and LED indicators.



'386/V

Complete 25MHz '386 Vertical System. 65MB Drive!
Only \$3995.00

33MHz systems also available!

ZEOS 25MHz and 33MHz 80386 systems are the fastest, most advanced available anywhere. Review after review, these ZEOS systems are selected as the best price/performance buys. A power-user's dream.

- High Speed Zero-Wait 64K CACHE.
- Genuine 32-bit Intel 386-25 or 33MHz CPU.
- 1MB Zero-Wait 32-bit DRAM expandable to 8MB on board plus 16MB 32-bit expansion (24MB total).
- Fast 65MB Seagate Drive, 1.2MB FDD.
- Ultra high speed Hard/Floppy controller, 1:1 interleave, 800 KB/sec transfer rate.
- High-Res Amber Display, Tilt/Swivel Base.
- 101 Key ZEOS Tactile/Click keyboard.
- High Speed Serial and Parallel Ports.
- 1-32, 6-16 and 1-8 bit slots.
- 80387 and Weitek 3167 support.
- Heavy Duty 6-bay Verticle Case.

Desktop configurations also available.

Order Now Toll Free

800-423-5891

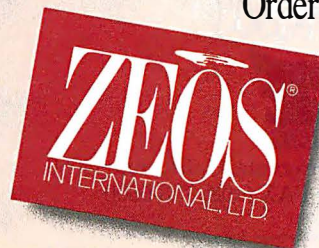

FAX Orders Dial: 612-633-2310
In Minnesota Call: 612-633-4591
MasterCard, VISA and COD
Open days, evenings and weekends
Se habla Español.



Talk to your customer instead of your computer

Control your IBM PC while you control your audience. All by yourself, you can give picture-perfect, PC-assisted sales presentations, make super group demonstrations, or even teach classes. In every case your attention will be focused on your audience, not on your PC.

The secret is Remote Keyboard... a hand-held control device for running and manipulating programs on your PC or compatible from as far away as 50 feet.

A fingertip touch on a button lets you display, alter or change data in the blink of an eye. You can roam the room, keeping in eye contact with your audience while controlling your computer with Remote Keyboard's infrared signals.

"It's neat," Remote Keyboard users say. They're right, too. It fits the palm of your hand and is UL-listed and FCC-approved. With Remote Keyboard, you don't need an aide at the keyboard. You're in control of the audience and your PC.

It installs in less than a minute — without tools! Even if you're all thumbs, Remote Keyboard is simple to install. It has just three components — your wireless, hand-held device, a receiver which plugs into your PC's serial interface, and a software driver on a diskette. Put it together, touch a button, and you're in complete control.

Pay more attention to your prospects, and sell more successfully! Remote Keyboard is a wonderful teaching tool, too, and a must for PC-assisted product demonstrations.

JUST \$395...30-DAY MONEY-BACK GUARANTEE...USE YOUR CREDIT CARD. This handy device is just \$395.00 plus \$5.00 for shipping and handling. It comes with a 1-year limited warranty. So put yourself in control...order RISK-FREE now by calling:

(800) 331-3903

FORTÉ
COMMUNICATIONS

680 W. Maude Avenue • Sunnyvale, California 94086
Phone (408) 733-5100 • FAX (408) 733-5600

Remote Keyboard is a trademark of Forté Communications, Inc.
IBM and IBM PC are trademarks of IBM Corporation. © 1989 Forté Communications, Inc.

complexity of a system is "algorithmic complexity," or the size of the system's minimal description. Pi, for example, though an infinitely long real number, is not particularly complex because you can write a relatively simple program to compute it. Another kind of complexity is "computational," which would measure not the size of the program but how long it would take to run.

The problem with these and other quantitative descriptions of complexity that Pagels explores is that they do not lie solidly between order and chaos. The "algorithmic" measure, for example, would ascribe a higher degree of complexity to a random string than to one with some inherent order. Of course, all these measures fail with language, while simple and ordinary sequences of words can be used to describe extraordinarily complex concepts: "To be or not to be." Pagels fails to discover an adequate and binding definition for complexity. Instead, he presents, in a suitably complex mode, several qualities or "themes" shared by complex systems:

- They tend to be selective systems, employing, like evolution, the principle of "survival of the fittest."
- They tend to emphasize parallel over serial processes.
- They often discover new principles based on nature.

Despite the difficulties of numerical or verbal description (there is no adequate theory of complexity; that's why it's new), Pagels's chapters on the sciences of complexity are rigorous and spirited enough to convey to the reader an intuitive sense of the nature of complexity. For example, on mathematics, Pagels comments, "I believe that it is because of the possible complexity arising out of a simple logical system that mathematics acquires its quality of independence and auton-

omy from the mind."

The entire first half of *The Dreams of Reason* reads like a review of recent popular scientific literature (although Mandelbrot and his fractals are curiously absent). Pagels reviews the startling new theory of chaos, as laid out in James Gleick's recent book. Chaos theory has been used to describe everything from global weather patterns to leaky faucets, and recently even the behavior of computer networks. Such systems are characterized by extreme nonlinearities, which results in an almost infinite sensitivity to initial conditions. Thus, even if the laws governing a chaotic system are known, such a system cannot be simulated without defining its initial state to anything other than infinite precision, which is impossible.

The next chapter is on cellular automata, sophisticated versions of the popular computer game called Life that can simulate complex biological systems. With such tools, scientists watch the evolution of pseudobiological systems and have observed some fascinating phenomena: a) The "cells" of the simulation tend to get trapped in a given configuration, but not necessarily in the optimum one for survival; b) when they do achieve an optimum form, they may not be able to maintain it in the face of recurring mutation; and c) a large amount of spontaneous order arises in the evolutionary process. How well these simulations match the operations of natural evolution can be debated, but they certainly provide insights into the workings of more artificial parallel and selective complex systems.

The second part of *The Dreams of Reason* is dedicated to Pagels's philosophical musings on the implications of the sciences of complexity. He addresses the most complex system known to man: the human brain. He insists that a fundamental understanding of the brain and human cognition

continued

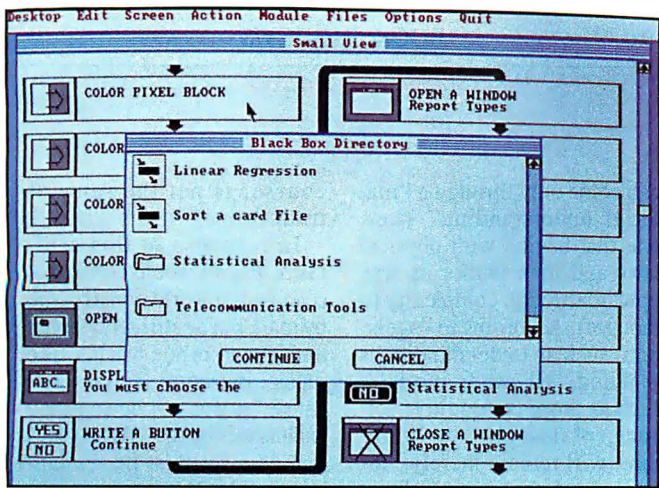

OOPS. Using sophisticated Object-Oriented Programming, Matrix Layout gives you the power to build complete applications faster than you thought possible. And that's just the beginning.

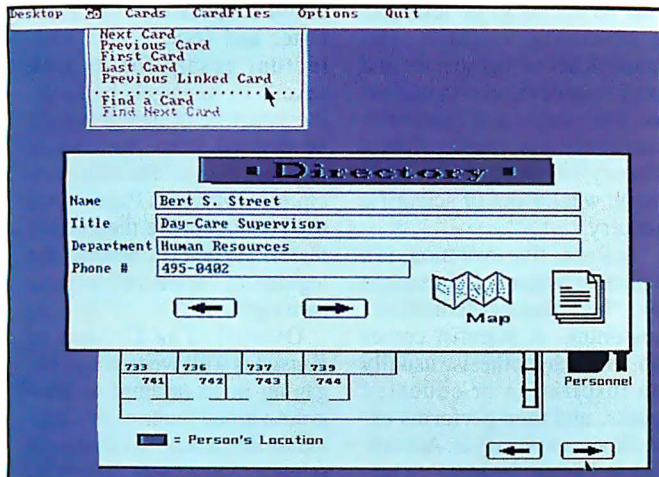

Hypertext. Layout puts all the features of Hypercard® on your PC and in your programs. Use Layout's graphical user interface to create documents with action links to related documents in any file. Or to create hyperlink applications.

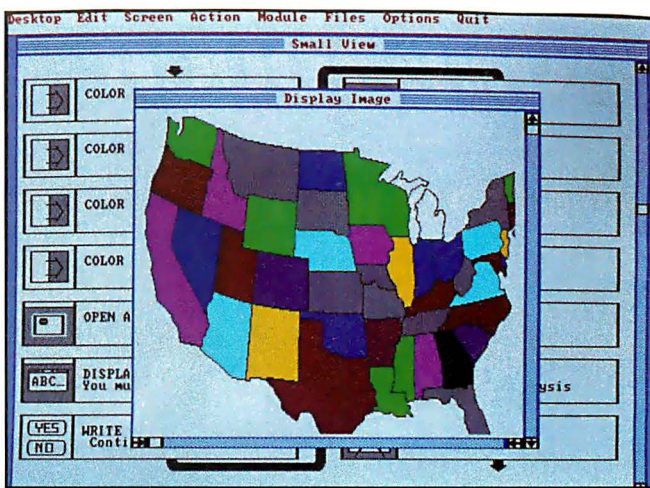

CASE. Layout's Computer Aided Software Engineering functions let you design programs using an intuitive flowchart model. Then, Layout can automatically turn your flowchart into source code or even an .EXE file.

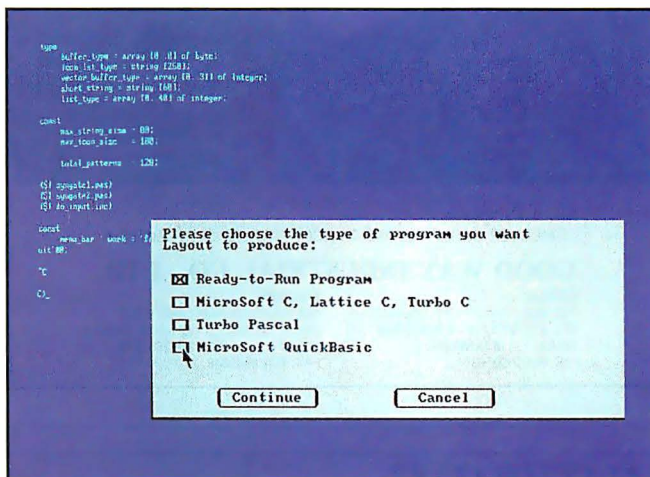

Plus, your favorite programming language(s). Using Layout's tools, you can cut your coding time up to 70 percent, and still produce ready-to-run programs in your choice of languages.

A Great Programming Tool Should Contain All Of The Above.

Presenting Matrix Layout, the first full software development system for the PC to promise you all the above. And deliver.

Sit down to Layout's intuitive user interface and in minutes you'll be using advanced OOPS (Object-Oriented Programming System) and CASE technology to build your program. Simply draw a flowchart indicating the windows, buttons, menus, text, and graphics you want.

A Cut Above Other Tools.

Layout also provides flowchart elements for Hypertext data base capabilities, math functions, variable management, conditional branching and looping. And, its open architecture allows you to build your own Black Box elements — to create exactly the program you want.

When your flowchart is ready, Layout uses

artificial intelligence technology to automatically turn it into code — Turbo Pascal, Turbo C, Microsoft C, QuickBasic or Lattice C. Or create a ready-to-run .EXE file right from within Layout.

It's so efficient, your programs will run incredibly fast, even on a standard 256K PC. Plus, they'll include Layout's automatic mouse support and device independence.

All The Above And More.

- *Matrix Helpmaker* helps you create context-sensitive help and complete on-line documentation for your programs.
- *Matrix Paint* offers a full set of graphics

tools, scanner support, and clip-art files to make your programs look professional.

- Finally, *Matrix Desktop* gives you a simple, visual way to organize files and disks.

For A Lot Below.

Layout delivers all the above for just \$149.95 — a lot below what you'd expect. Especially when you throw in free customer support, no copy protection, and a 30-day, money-back guarantee.

Video Tape Offer. Still not convinced? Call for a copy of our Matrix Layout VHS demonstration video at 1-800 533-5644 (just \$9.95 for shipping and handling, credited against your purchase). In Massachusetts, call (617) 567-0037.

Any way you look at it, Matrix Layout is the ultimate PC programmer's tool. And that's the bottom line.

M A T R I X
L A Y O U T

Matrix Software Technology Corporation • One Massachusetts Technology Center • Harborside Drive • Boston, MA 02128 • (617) 567-0037

Matrix Software/UK • Plymouth, England • 0752-796-363 • Matrix Software/Belgium • Geldenaaksebaan 476 • 3030 Leuven • 016202064
The following are registered and unregistered trademarks of the companies listed: Matrix Layout, Matrix Paint, Matrix Helpmaker, Matrix Desktop, Matrix Software Technology Corporation; Macintosh, Hypercard, Apple Computer, Inc.

BT 894

ONE TOUCH

YOU WILL GET AVAILABLE SOURCE & GUARANTEE FOR ALL OF DATA COMMUNICATION EQUIPMENTS FROM GOOD WAY

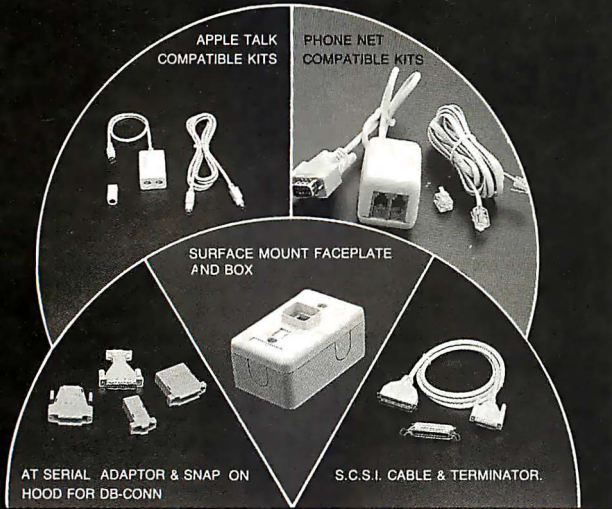

Main Products:
COMPUTER CABLE. NETWORK ACCESSORIES DATA SWITCH

GOOD WAY INDUSTRIAL CO., LTD.

Office:
P.O. BOX 91-202 TAIPEI, TAIWAN
TEL: (02) 5017197-8 • 5017360
TELEX: 12445 SUWORS
FAX: 886-2-5056377

Factory:
NO. 14-1 DAH HER LANE 2 SHI
TWNEN DISTRICT, TAICHUNG, TAIWAN
TEL: (04) 2551192-3 • 2551220
FAX: (04) 2542648

BOOK REVIEWS

can come only through a "material understanding" (i.e., one that begins with physical laws and then works its way upward through complexity to thought). According to Pagels, until such an understanding is reached, all other models, such as those of cognitive science, philosophy, or literature, will remain merely "intellectual fashion." He is consistently and harshly critical of the conclusions of anyone he deems to be less than a practicing scientist. His staunch belief that science and only science expresses universal truth limits and eventually unravels his thesis that a theory of complexity must come wholly out of scientific inquiry.

Science, like evolution, is a selective system. It functions by "hypothetico-deductive" reasoning. A scientist comes up with a hypothesis, usually an inspiration or educated guess, and then performs experiments to verify it. According to Pagels, however, a scientific theory can never be proved true, it can only be proved wrong.

Revolutionary theories, like those of relativity or quantum mechanics, acquire a certain credibility if they survive long enough without being disproved, but they still cannot be proved positively. Thus, the evolution of science is like the evolution of life; the fittest survive the tests of time, but not necessarily as the optimum configuration. This is a valid and logical explanation of the progress of science. The problem, however, is that Pagels's writing is simultaneously infused with the opposite view—namely, that science expresses absolute and unshakable truth, knowing nature in a positive sense from "the bottom up." This belief is at odds with the evolutionary view of science, which tells us that, like cellular automata, scientific theories do not necessarily settle in the optimal configuration, only one that will survive. And, as Pagels himself says, "Survival, of

course, is not the same as truth."

In response to this criticism, Pagels would admit that science is a world constructed by man, but he still sets it apart and above other worlds like music, literature, and law because "it was not determined exclusively by us." Pagels says that as a scientist he remembers only "concepts and facts," as opposed to "humanists" whose thought is "dedicated to political opinion, taste, and style... and intellectual gossip for its own sake." If, as Pagels believes, the structure of thought could be derived from the laws of physics, then all the other disciplines for which Pagels feels such contempt are themselves materially determined and are legitimate "sciences" in their own right.

Overall, *The Dreams of Reason* is well written and engaging in its attempt to integrate a broad range of developments into a new "synthesis of science." The irony, however, is that Pagels's refusal to recognize ideas from those people who are not practicing scientists grounds his discourse in a deterministic, noncomplex paradigm. His difficulty with defining complexity, for example, would certainly be eased by considering other postmodern thinkers, such as philosopher Gilles Deleuze, historian of science Michel Serres, or even novelist Thomas Pynchon. The sciences of complexity are interdisciplinary. A vision that integrates computers and biology, as well as neurology and quantum mechanics, should be able to accommodate the complex philosophies of thought and language in its quest to select a theory of the shining but presently uncharted region between order and chaos. ■

CONTRIBUTORS

Eric Bobinsky works at the NASA Lewis Research Center in Cleveland, Ohio. **David A. Mindell** is a technical writer and consultant living in Aspen, Colorado.

MATHPAK 87

High Performance 80x87 Software

Over 130 assembler coded routines which are designed to take full advantage of 80x87 math coprocessors.

Designed for Speed

Up to 20.X faster than high level language!

1 K complex FFT on a 386/20 takes 0.28s; real 0.17s (1.85s & 1.0s on an IBM XT); dot product (length 10,000) in 0.07s (0.49s on XT).

MATHPAK 87 provides you with the fastest, most convenient and comprehensive set of tools available.

MATHPAK 87 includes: 65 vector/scalar routines; 24 complex vector/scalar routines; 11 matrix utility routines (add, subtract, multiply, transpose, ...); LU decomposition/back-solving routines for real & complex systems; gaussian elimination; matrix inversion, tridiagonal equation solver routines; EISPACK type eigenvalue/vector routines; statistical routines; FFTs (1-D, 2-D, complex, real, convolution); spectral analysis routines (windows: Parzen, Hamming, ...); routines for numerical integration & solution of differential equations; and missing functions for Modula-2 and Pascal: tan, log10, alog10, power, sinh, cosh, & tanh; and more.

Widely used in signal & image processing, simulation, spectral analysis, etc.

Timings (COMPAQ 286, 12MHz)
Execution Time for 100,000 Operations

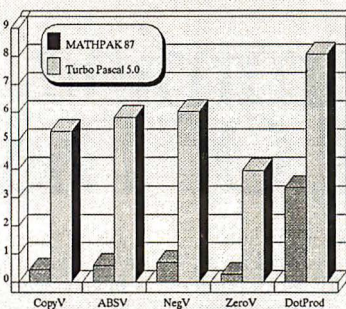

Order Today!

Precision Plus Software
1239 Sir David Drive
Oakville, Ontario
Canada L6J 6Y9
Tel: 416-829-1511
Fax: 416-829-1742

Users like *MATHPAK 87* & take the time to tell us!

\$99US for Turbo Pascal version. \$119US for Fortran (MS, IBM Prof. or F77L), C (MS, Turbo or Lattice), and Modula-2 (Logitech or ITC) versions. Add \$69US for complete source code. Add \$5 for shipping. Specify compiler.

International Dealer: SOS Software Service, GmbH, Alter Postweg 101, 8900 Augsburg, West Germany, Tel: 0821/57 1081, Fax: 0821/57 7659.



BLINDING SPEED
COMPLETE COMPATIBILITY

Introducing the high speed modems from U.S. Robotics

Until now, high speed modem users had the best of one world. They either had speed or compatibility. U.S. Robotics just changed all that.

THE BEST OF ALL WORLDS...

With the new line of high speed modems from U.S. Robotics — the Courier HST, the Courier HST Dual Standard and the Courier V. 32 — you can now have both the highest speeds and the most compatibility.

For speed — it's the Courier HST which delivers throughput over 24,000 bits per second with MNP® level 1-5 error control and compression. And it still costs less than \$1,000.

For Compatibility — the Courier V.32 provides CCITT standard modulations from 300 bps to 9600 bps for under \$1,495. And with MNP levels 1-5 you will get complete data integrity plus throughputs approaching 19,200 bps.

For the best of all worlds — it's the Courier HST Dual Standard, combining the blinding speed of the Courier HST with the compatibility of the V. 32. At \$1,595, it costs less than some featureless V. 32-only modems.

U.S. ROBOTICS — THE EXPERT'S CHOICE

You would expect the broadest high speed modem line from U.S. Robotics. We manufactured our first HST in 1987, and it quickly became the standard on over 5,000 bulletin boards and over 40,000 users. Rated #1 by *Data Communications* magazine, it confirmed what our customers knew all along — U.S. Robotics delivers the best modem value. And we've been doing that for 13 years — for almost 1,000,000 customers.

When you look for high speed modems, don't settle for half a solution. Look to U.S. Robotics. Call today for details on the high speed modems that give you the best of all worlds.

Call 1-800-Dial USR. (1-800-342-5877)
or (312) 982-5001 in Illinois

U.S. Robotics®

The Intelligent Choice in Data Communications

8100 North McCormick Boulevard, Skokie, Illinois 60076
U.S. Robotics, Courier and HST are trademarks of U.S. Robotics, Inc. Other computer and software names identified by ® or ™ are trademarks of their respective manufacturers. Prices are suggested retail prices in U.S. Dollars.
For sales in the United Kingdom, please call Miracom, Ltd., Ipswich, England.
Telephone: 0473233888. For Canadian sales, call 1-800-553-3560.

Programmer's Paradise offers an



WE'LL MATCH NATIONALLY ADVERTISED PRICES.

ASSEMBLY LANGUAGE

	LIST	OURS
Advantage Disassembler	295	279
ASMFLOW	100	90
Incra	180	CALL
MS Macro Assembler	150	105
OPTASM	125	105
SOURCER	100	89
w/BIOS SOURCE	140	125
Turbo Assembler/Debugger	150	112
Visible Computer: 80286	100	89

BASIC

db/LIB	139	121
Facelt	99	90
GraphPak Professional	149	127
MS BASIC/6.0	295	199
MS QuickBASIC 4.5	99	69
QuickPak Professional	149	129
QuickPak Scientific	79	70
QuickWindows w/Source	99	90
QuickWindows Advanced	139	125
SoftCode	79	69
True BASIC	100	80
Turbo Basic	100	75

C CODE GENERATORS

Databoss Appli. Generator	399	379
Matrix Layout	150	139
Pro-C	495	459
w/Workbench	595	569

C LANGUAGE

C-terp	298	232
Lattice C	450	289
Microsoft C	450	299
QuickC 2.0	99	69
Turbo C v. 2.0	150	112
Turbo C v. 2.0 Professional	250	187
Watcom C	295	269
Zortech C++	150	129
w/source	250	209

C LIBRARIES/UTILITIES

C ASYNCH MANAGER	175	137
C TOOLS PLUS/5.0	129	99
C Utility Library	199	139
Essential Communications	185	125
Greenleaf Comm Library	229	169
Greenleaf Functions	209	155
Greenleaf SuperFunctions	265	189
PC-lint	139	101
PCYACC	395	359
TimeSlicer	295	279
w/source	1000	899
Turbo C TOOLS/2.0	149	115
vLIB	99	89
w/source	149	129

C GRAPHICS

Essential Graphics	299	229
w/source	595	509
GraphicC	395	322
GSS Graphic Dev. Toolkit	595	509
HALO '88	325	229
HALO '88 for MS Devel.	595	399
TurboHALO	100	80

C SCREENS/WINDOWS

Curses (Aspen)	159	145
w/Source	349	319
C-Scape	299	282
w/Look & Feel	399	379
C-Worthy	195	165
w/Forms & Source	495	439
Greenleaf DataWindows	295	209
Greenleaf Makeform	125	90
HI-SCREEN XL	149	129
JAM	750	684
JYACCFORMAKER	495	453
PANEL Plus	495	395
Vermont Views	395	CALL
w/Source Code	790	CALL
Vitamin C	225	162
VCScreen	149	109

COBOL LANGUAGE

Micro Focus:		
COBOL/2 w/ Toolset	1800	1465
COBOL/2 Toolset	900	733
PC-CICS	1495	CALL
Personal COBOL	149	121

COMMUNICATIONS

Carbon Copy Plus	195	135
Close-Up (Support)	245	222
Close-Up (Customer)	195	116
Co/Session (2 user license)	249	227
Support	175	157
Application	125	116
MIRROR III	100	90
RELAY Gold	250	229
RELAY Silver	150	139

dBASE LANGUAGE

CLARION	695	599
Clear +	200	165
Clipper	695	439
dBASE III Plus	695	399
dBASE IV	795	485
dBASE Graphics for C	90	69
dBASE ON LINE	69	60
dBASE Programmers Utilities	90	79
dBASE Tools for C	90	69
dBASE Tools for Pascal	90	69
dBFAST	100	75
dBUG	195	179
dQUERY	150	129
Flipper	195	182
FoxBASE +	395	249
Genifer	395	259
Integrated Dev. Library	149	135
Paradox v. 3.0	725	539
QuickSilver	599	369
R:Base for DOS	725	529
R & R	150	129
w/Clipper/FoxBASE module	199	179
Say What!	50	45
Scrimage	CALL	CALL
SilverComm Library	150	139
The Documentor	295	229
Tom Rettig's HELP	120	CALL
Tom Rettig's Library	100	80

UI Programmer	295	229
XDB-SQL	495	419
DEBUGGERS		
386 DEBUG	195	145
Periscope I/512 K	795	675
Periscope II	175	155
Periscope IIX	145	129
Periscope III	1395	1255
Quaid Analyzer	200	179
Sherlock	195	179
DESKTOP PUBLISHING		
HALO DPE	195	162
MKSSQPS	495	479
Pagemaker	695	523
Ventura Publisher	895	525
DISK/DOS UTILITIES		
Command Plus	90	70
Command Tips	90	80
Disk Optimizer	60	55
FANSI CONSOLE	75	66
FASTBACK Plus	189	142
hTest: hformat	90	80
MACE Utilities	99	90
Magellan	139	CALL
MKS Toolkit	199	165
Norton Commander	89	56
Norton Utilities	100	61
Norton Utilities, Adv. Ver.	150	101
PC/Tools Deluxe	80	70
Vcache	50	47
Vfeature	80	75
Vfeature Deluxe	120	111
Vopt	50	47
Xtree	70	60
Xtree Pro	129	111
ZYINDEX 3.0	95	85
ZYINDEX PROFESSIONAL	295	265
EDITORS		
BRIEF	195	CALL
Epsilon	195	151
KEDIT	150	120
ME	89	79
w/source	189	169
MKS VI	149	125
Multi-Edit	99	90
Norton Editor	75	70
PC/EDT+	295	269
Pi Editor	149	129
Slick Editor	195	155
SPF/PC	245	185
VEDIT PLUS	185	115
Vq	270	CALL
FILE MANAGEMENT		
Btrieve	245	185
Xtrieve	595	459
Report Executive	145	109
Btrieve/N	595	459
Xtrieve/N	595	459
Report Option/N	345	279
CBTREE	159	141
C-Index for MSC	195	175
C-Index for Turbo C	100	90
C-Index Plus	395	349
PC-ASC	395	318
c-tree	495	395
r-tree	295	241
c-tree/r-tree bundle	650	523
CQL Query System	395	332
DBC III	250	CALL
DBC III PLUS	750	CALL
db.FILE	395	309
db.RETRIEVE	395	309
Essential B-Tree	99	89
w/source	198	179
XQL	795	599
FORTRAN COMPILERS		
F77L	477	429
GRAPHER	199	179
Lahey Personal FORTRAN 77	95	89
MS FORTRAN	450	299
RM/FORTRAN	595	479
SURFER	399	359
FORTRAN LIBRARIES/UTILITIES		
FITLIB	350	305
FFTLIB	350	305
Grfatic	135	119
MINIPACK1-LIB	350	305
Plotmatic	135	119
SPARSSEM	350	305
Spindrift Library	149	135
Tekmar Graphics Library	195	169
LINKERS/LIBRARIANS		
OPTLIB	49	45
OPTLNK	125	109
Plink86plus	495	279
Plib	195	149
PolyLibrarian I	99	90
PolyLibrarian II	149	131
.RTLink	195	185
MODULA-2		
JPI Top Speed Modula-2	100	90
LOGITECH Modula-2		
Development System	249	199

Solid B + Toolbox	100	90
Stony Brook Modula-2 Development Package	345	309
OBJECT-ORIENTED PROGRAMMING		
ACTOR	495	423
C-talk	150	129
C.Talk/Windows	450	399
Smalltalk/IV	100	85
Communications	50	45
EGA/VGA Color Ext.	50	45
Goodies #1, #2 or #3	50	45
Smalltalk/IV286	200	169
Smalltalk/IV MAC	200	179
OPERATING SYSTEMS		
Microport:		
System V/AT (complete)	649	549
AT Runtime System	249	209
286 DOS Merge	249	209
SCO:		
XENIX Sys V (comp.)	1295	999
Operating System	595	479
WENDIN:		
Operating System Toolbox	99	80
PCNX	99	80
PCVMS	99	80
Wendin-DOS	139	109
OS/2 DEVELOPMENT TOOLS		
Btrieve for OS/2	595	455
Epsilon for OS/2	195	151
Greenleaf DataWindows	395	CALL
GSS Dev. Toolkit for OS/2	CALL	CALL
LOGITECH Modula-2	349	279
MKS AWK (OS/2)	179	159
MKS Toolkit (OS/2)	495	439
MS Languages	CALL	CALL
NEWS/2	495	CALL
Panel Plus for OS/2	495	395
PolyAWK for OS/2	199	179
Vitamin C (OS/2)	345	279
Windows for Data (OS/2)	395	349
PROTOTYPING		
Dan Bricklin's Demo Program II	195	179
Instant Replay	150	131
Proteus	149	129
Screen Machine	79	60
Show Partner	99	89
Show Partner F/X	350	319
REFERENCE GUIDES		
Command Tips	90	80
Norton On-Line Prog. Guide	100	75
Tom Rettig's HELP	120	105
PASCAL COMPILERS		
Microsoft Pascal	300	189
Turbo Pascal	150	112
Turbo Pascal 5.0 Professional	250	187
TURBO PASCAL LIBRARIES/UTILITIES		
B-tree Filter	125	99
DATABOSS	399	359
Pascal ASYNCH MANAGER	175	137
PCX Toolkit	90	80
POWER SCREEN	129	99
Turbo Analyst	99	79
Turbo ASYNCH MANAGER	129	99
NEW RELEASES		
Vermont Views 1.0		
Vermont Creative Software's new generation of Windows for Data. User-interface library for forms, windows, menus, help, and keyboard handling. Menus in any style. Forms can be larger than display window, have choice lists, context-sensitive help, flexible decimal, date, time, and toggle fields. Mini word processor. International language portability. List: \$395		OURS: CALL
Microsoft QuickCV. 2.0		
Now features incremental compilation and linking, resulting in greatly improved compilation speed. Also now includes a built-in, in-line assembler. Hypertext technology has been utilized in QuickCV's new on-line reference system. List: \$99		OURS: \$69
.RTLink		
Fast, new overlay linker. User RTLs (Run Time Libraries) to prevent repetitive storage, on disk, of code that is common from one .EXE file to the next. Use of .RTLs results in significantly smaller .EXEs resulting in reduced disk space requirements. List: \$195		OURS: \$179

Unbeatable Selection 1-800-445-7899

This Month's Specials from MORTICE KERN SYSTEMS

	LIST	OURS
MKS AWK	99	82
MKS LEX & YACC	249	207
MKS Make	149	125
MKS RCS	189	157
MKS SQPS	495	479
MKS Toolkit	199	165
MKS Trilogy	119	99
MKS VI	149	125

	LIST	OURS
TurboGeometry Library	150	135
Turbo MAGIC	199	179
TURBO META-MENU	149	139
Turbo Plus v. 5.0	100	80
Turbo POWER TOOLS PLUS/5.0	149	115
Turbo Professional 5.0	125	99

SCIENCE/ENGINEERING SOFTWARE

CSS	495	459
Derive	200	179
DesignCAD 3-D	299	219
EXP	150	129
HiWIRE-Plus	895	805
MathCAD	349	279
MICRO-CAP III	1495	1269
Microstat-II	395	349
Systat	595	549
Tango PCB Series II	595	569
TECH*GRAPH*PAD	395	359

TRANSLATORS

Bas. C (Commercial)	375	323
Bas. Pas (Commercial)	280	242
BASTOC	495	399
Brooklyn Bridge	130	CALL
dB2C	299	272
dBx TRANSLATOR	550	469
PROMULA.FORTRAN	450	409
w/Library Source	745	669

386 SOFTWARE

386ASM/LINK	495	399
386MAX	75	66
386MAX PROFESSIONAL	129	115
Concurrent DOS 386 (3 User)	395	349
DESQview/386	190	165
F77L-EM/32	895	805
High C 386	895	799
Microport		
System V/386 (complete)	899	799
Runtime System	299	269
MS Windows/386	195	130
NDP C 386	595	529
NDP FORTRAN-386	595	529
SCO XENIX		
Operating System	695	589
Sys. V 386 (complete)	1495	1195
VP/IX (2-USERS)	495	399
VP/IX (unlimited users)	995	799
VM/386	245	209
VM/386 Multiuser (unlim.)	895	CALL

OTHER PRODUCTS

FLOW CHARTING II	229	207
MuLisp-87	300	219
MuLisp-87 Interp/Compiler	400	299
PC Scheme	95	79
Pfinish	395	215
PolyDoc	199	179
Source Print	97	80
Tree Diagrammer	77	70

BLAISE COMPUTING

ASYNCH MANAGER	175	137
C TOOLS PLUS/5.0	129	99
EXEC	95	76
KeyPilot	50	45
PASCAL TOOLS / TOOLS 2	175	137
POWER SCREEN	129	99
RUNOFF	50	45
Turbo ASYNCH MANAGER	129	99
Turbo C TOOLS/2.0	149	115
Turbo POWER TOOLS PLUS/5.0	149	115

BORLAND

Eureka: The Solver	167	126
Paradox 3.0	725	543
Quattro	247	185
SideKick Plus	200	149
Sprint	200	149
Superkey	100	75
Turbo Assembler/Debugger	150	112
Turbo Basic	100	75
Database Toolbox	100	75
Editor Toolbox	100	75
Turbo C 2.0	150	112
Turbo C 2.0 Professional	250	187
Turbo Pascal 5.0	150	112
Turbo Pascal 5.0 Professional	250	187
Database Toolbox	100	75
Editor Toolbox	100	75
Gameworks Toolbox	100	75

	LIST	OURS
Graphix Toolbox	100	75
Numerical Methods Toolbox	100	75
Tutor	70	55
Turbo Prolog	150	112

GREENLEAF SOFTWARE INC.

Greenleaf Bus. Math Lib	325	229
Greenleaf Comm Library	229	169
Greenleaf DataMath Interface	75	69
Greenleaf DataWindows, DOS	295	209
OS/2 Version	395	299
Greenleaf Functions	209	149
Greenleaf MakeForm	125	99
OS/2 Version	170	135
Greenleaf SuperFunctions	265	189
Greenleaf ViewComm	495	CALL

LAHEY

F77L	477	429
F77L-EM/16	695	639
F77L-EM/32	895	805
Lahey/AI OS/386 OP/SYS	195	179
PERSONAL FORTRAN 77	95	89

MICROSOFT

MS BASIC/6.0	295	199
MS C	450	299
MS COBOL V. 3.0	900	599
MS Excel	495	299
MS FORTRAN	450	299
MS Learning DOS	50	40
MS Mach 2.0	495	329
MS Macro Assembler	150	105
MS Mouse Bus or Serial		
w/Paintbrush & Mouse Menus	150	105
w/EasyCAD	200	149
w/Paintbrush & Windows	350	229
MS OS/2 Prog. Toolkit	300	199
MS Pascal	99	69
MS QuickBASIC	99	69
MS QuickC 2.0	99	69
MS Windows	195	130
MS Windows/386	500	319
MS Windows Dev. Kit	450	285
MS Word		

NOVELL

Btrieve Standalone	245	185
Btrieve for DOS 3.1 Networks	595	459
Btrieve for OS/2	595	459
Btrieve for XENIX	595	459
Btrieve Multitasking Add-on	345	279
Btrieve IBM PC Network Add-on	345	279
NetWare C Interface for DOS	295	239
NetWare MHS	100	79
NetWare MHS Interface Guide	145	129
NetWare RPC	950	759
NetWare SQL	595	459
NetWare System Calls for DOS	195	159
Report Executive	145	109
XQL	795	599
Xtrieve	595	459

RAIMA CORPORATION

db_FILE	395	322
Single user w/source code	890	725
Multi-user	595	485
Multi-user w/source code	1390	1133
db_RETRIEVE	395	322
Single user w/source code	890	725
Multi-user	595	485
Multi-user w/source code	1390	1133
WKS Library	195	179

SYSTEMS & SOFTWARE

LINK & LOCATE	350	309
LINK & LOCATE ++	395	359
SoftProbe II/TX	395	359

PROGRAMMER'S POLICIES

Phone Orders
Hours 9 AM-7 PM EST. We accept MasterCard, Visa, American Express. Include \$4.00 per item for shipping and handling. All shipments by UPS ground. Rush service available.

Mail Orders
POs by mail or fax are welcome. Please include phone number.

International Service
Phone number required with order. Call or fax for additional information.

Dealers and Corporate Accounts
Call for information.

Unbeatable Prices
We'll match nationally advertised prices. (Subject to same terms and conditions.)

Return Policy
30-day no-hassle return policy. Some manufacturer's products cannot be returned once disk seals are broken.



Your Hot Line for Development Tools!

Developers require programming tools and services that address their changing development needs. Novell® supplies tools that shorten the application development cycle. **Btrieve®** set the file management standard for PC applications. **Xtrieve™** and **Report Executive®** provide query and report writing capabilities. Now Novell offers **NetWare SQL™!** Combined with XQL, you have an unbeatable set of tools for implementing applications with relational data management capabilities.

NetWare SQL NetWare SQL is an open interface relational database engine providing back-end database services to a wide variety of front-end applications. Integrated with the NetWare operating system, NetWare SQL's server-based technology enables efficient, reliable, and high performance distributed data management. By using NetWare SQL, your applications will run faster and deliver higher levels of reliability and data integrity. Plus, your applications can share data with popular packages being offered by major software vendors who are also utilizing NetWare SQL. List: \$595 Ours: \$459

XQL XQL gives you the convenience and power of a 4th generation language by allowing you to use SQL for relational data management within your application programs. Your XQL applications can run stand-alone, on DOS networks, or you can combine it with the NetWare SQL database server for distributed processing capabilities. List: \$795 Ours: \$599

NetWare System Interface NetWare System Calls and the NetWare C Interface, offer over 300 system-level application programming interfaces (APIs) for direct access to NetWare operations such as network security, fault tolerance, network management, and network accounting. NetWare System Calls List: \$195 Ours: \$159 NetWare C Interface List: \$295 Ours: \$239



NOVELL®

In NY: 914-332-4548
Customer Service: 914-332-0869
International Orders: 914-332-4548
Telex: 510-601-7602

Fax: 914-332-4021
Call or Write for Latest Free Catalog!

1-800-445-7899

Programmer's Paradise

A Division of Voyager Telemarketing
55 South Broadway, Tarrytown, NY 10591

Circle 223 on Reader Service Card



NOW YOUR SOFTWARE CAN TEST ITSELF.



Your customers expect software that works. All the time. The key to software quality is exhaustive testing. It's also an engineer's worst nightmare. But it doesn't have to be. Because now you can automate your software testing.

Introducing the Atron Evaluator. The first and only non-intrusive automated PC-based software testing tool.

The Atron Evaluator automatically runs your software regression testing programs. All of them. All day. All night. Giving you thoroughly tested, higher quality software.

The Atron Evaluator is hardware-based. And since it's non-intrusive, software behavior is tested without the risk of alteration. Once your tests have run, you can refer to automatically generated test reports to double-check test results.

The Atron Evaluator saves time. And time makes you money. Development cycles are shortened, so your software gets to market sooner. And while your test programs are running, you can be more productive. Start a new project. Or go home.

For more information about the Atron Evaluator, call us at **1-800-283-5933**. And put an end to your worst nightmares. Automatically.



A Division of CADRE Technologies

Saratoga Office Center
12950 Saratoga Avenue
Saratoga, California 95070

Circle 31 on Reader Service Card
In Europe, contact:

Elverex Limited, Enterprise House
Plassey Technology Park, Limerick, Ireland
Phone: 061-338177

QA Training Limited, Cecily Hill Castle
Girencester, Gloucestershire, GL7 2EF, England
Phone: (0285) 5888

WHAT'S NEW

HARDWARE • SYSTEMS

Network Station Designed Around X Windows

The NCD16 is a 12.5-MHz 68000-based personal computer with 1 megabyte of RAM. It's built in the tradition of the low-priced, intelligent personal computers that boot from an Ethernet host.

This intelligent workstation, however, is designed to also run X Windows software, an MIT-designed software concept that has been endorsed by IBM, DEC, Hewlett-Packard, and others. X Windows lets the NCD16 support multiple applications running on hosts under the Unix and VMS operating systems; it runs the applications between the hosts and the NCD16 at the 10-Mbps Ethernet data rate. (Compare that to the maximum ASCII terminal-to-host rate of 38.4 kbps.)

Once you've downloaded X Windows from your host (or you've booted up with an optional PROM), you address particular hosts with the mouse by clicking on the representative windows. The 16-inch monochrome display with 1024- by 1024-pixel resolution promptly responds with a 105-dpi bit-mapped graphic, something available before only on stand-alone PCs, proprietary LANs using data rates afforded by optical fiber technology, and higher-priced workstations.

The Ethernet adapter fits into the NCD16's only slot. **Price:** \$2550; PROM, \$300. **Contact:** Network Computing Devices, Inc., 350 North Bernardo Ave., Mountain View, CA 94043, (415) 694-0650. **Inquiry 1151.**



The X Window-based NCD16 computer has an Ethernet link.

This 80386 System Eliminates the 80286 Price Advantage

The Power 386-20 might just be the least-expensive 80386-based personal computer on the market. And it's not short on equipment. It comes standard with 1 megabyte of RAM, a 30-megabyte hard disk drive, a 1.2-megabyte 5 1/4-inch floppy disk drive or a 1.44-megabyte 3 1/2-inch floppy disk drive, and a 12-inch monochrome monitor.

There's also a Hercules-compatible graphics card, a 101-key Key Tronic keyboard, and room for five 16-bit and three 8-bit add-in cards.

Other standards include a 1-to-1 interleave controller for

two hard disk drives and two floppy disk drives, a parallel port for your printer, and room for two half-height internal peripherals and three half-height external drives. **Price:** \$1995.

Contact: Micro 1, Inc., 557 Howard St., San Francisco, CA 94105, (800) 338-4061; in California, (415) 974-5439. **Inquiry 1153.**

A Desktop with a Mainframe Punch

The Unisys Micro A is a redesign of the PW² Series 800 with a mainframe processor.

Basically, Unisys took an off-the-shelf 80386-based workstation, converted the 80386 processor into an I/O

and maintenance subsystem, and added a 48-bit mainframe A-series processor, an 80286 data communications coprocessor with four ports, and a Z80 SCSI coprocessor.

With the 16-bit 80386 acting as an I/O system, Unisys limits the power of the 48-bit main processor, company officials admit. Similarly, an 80286-based data communications processor with four RS-232C communications ports is overkill.

However, Unisys says that the goal was to design a desktop system that would bring down the price of a Micro A, whose predecessor is priced at about \$100,000. Upgrades with X.25 capabilities are planned.

Without modifications, the PW² Series 800 runs both OS/2 on the 80386 and the Series A Master Control Program/Advanced System (MCP/AS), which is the mainframe operating system designed for the A Series. It can also run as an 80386 with OS/2 alone.

At the heart of the Micro A processor is the single-chip A-Series mainframe processor, a 2- by 2-inch multichip package that contains the equivalent of 10.3 million transistors. The processor sits on a thick (two-board-width) AT add-in board within the 16-bit 80386-based motherboard. The processor board contains 2.5 megabytes of static RAM plus 12 megabytes of system RAM. The 80386-based motherboard contains 3 megabytes of RAM. **Price:** \$25,365; software, \$5000.

Contact: Unisys Corp., P.O. Box 500, Blue Bell, PA 19424, (215) 542-6512. **Inquiry 1150.**

continued

SEND US YOUR NEW PRODUCT RELEASE

*We'd like to consider your product for publication. Send us full information, including its price, ship date, and an address and telephone number where readers can get further information. Send to New Products Editor, BYTE, One Phoenix Mill Lane, Peterborough, NH 03458. Information contained in these items is based on manufacturers' written statements and/or telephone interviews with BYTE reporters. BYTE has not formally reviewed each product mentioned. These items, along with additional new product announcements, are posted regularly on BIX in the *microbytes.sw* and *microbytes.hw* conferences.*

Please, Squeeze My Data

When first approached with a real-time compression algorithm that would effectively double the number of bits it could squeeze into its QIC-40 streaming tape drives, Colorado Memory Systems said "No, thanks" to Stac of Pasadena, California.

But on further consideration, the company that made the QIC-40 a de facto standard decided to work with Stac to use the algorithm, as well as to promote it as the perfect data compression software for streaming tape drives.

The company also decided that the length of the tape could be increased from 600 feet to 1000 feet because, unlike standard audiocassette tapes, the drive mechanism that pulls the tape through the heads isn't the tape itself.

The result is the QFA-500, with 500 megabytes of memory backup capacity. It sits in a 5 1/4-inch form factor and backs up data at 4 to 6 megabytes per minute, depending on the data. Each QFA-500 needs 512K bytes of system RAM.

Price: \$1395; external, \$1795; XT/AT adapter, \$150; PS/2 adapter, \$300; tape cartridge, \$43.40.

Contact: Colorado Memory Systems, Inc., 800 South Taft Ave., Loveland, CO 80537, (303) 669-8000.

Inquiry 1155.

Lundy Monitor Features 1600 by 1200 Resolution

The Lundy 1612 is a 1600-by-1200-pixel color graphics monitor for the IBM AT, PS/2s, and compatibles. It comes with a high-speed graphics controller and support for leading software packages.

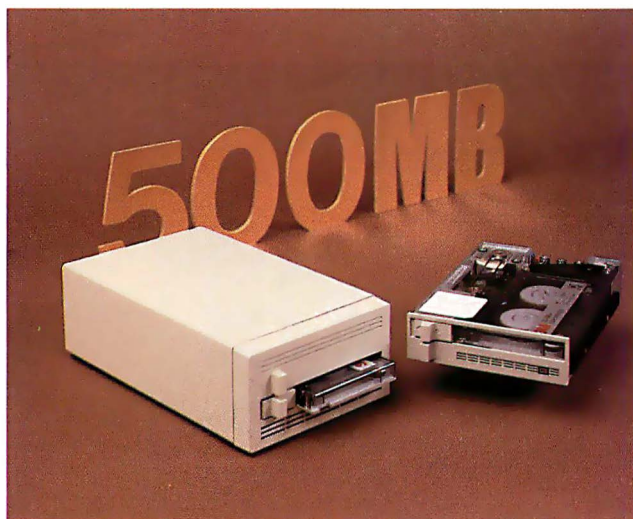

Data compression makes the QFA-500 a 500-megabyte tape drive.

Besides the 19-inch CRT unit, the Lundy 1612 includes an interface board installed inside the host computer, and an external box (typically sitting below the monitor's swivel stand) that holds the graphics controller and video RAM on two separate circuit boards. Interfaces are available for both the 16-bit AT bus and the Micro Channel bus, and Lundy plans to announce boards for other systems later this year. The standard AT board comes with a megabyte of video RAM.

The graphics controller uses proprietary ICs and the 50-MHz Texas Instruments TMS 34010—a 32-bit graphics processor that TI says is capable of drawing at the rate of 6 MIPS. The controller/monitor combination can display up to 16 colors simultaneously from a palette of 4096 at 1600-by-1200-pixel resolution, or, with software reconfiguration, 256 colors from a palette of 16 million at 1024-by-768-pixel resolution. The video RAM is up to 8 megabytes.

The company claims compatibility with more than 100 software packages.

Price: \$9950; MCA version,

\$10,150.

Contact: Lundy Electronics & Systems, Inc., Computer Graphics Division, One Robert Lane, Glen Head, NY 11545, (516) 671-9000.

Inquiry 1157.

Dot Matrix Just Got Better

The Proprinter X24E and XL24E are 24-wire, bi-directional dot-matrix printers rated at 288 characters per second in 12-character-per-inch draft mode. That's about 20 percent better than their predecessors, IBM says.

The print buffer has been enlarged to 14K bytes. The FontSet option provides for 11 additional fonts, and there's now a display panel for setup where there used to be DIP switches. You also get more paper-handling, paper-width, paper-weight, and programmable features than you probably care to have.

The printer's computer interface is parallel or, optionally, RS-232C or RS-422.

Price: X24E, \$899; XL24E, \$1199.

Contact: Consult your local telephone book's white pages for IBM Corp. or call (800) 426-2468.

Inquiry 1156.

Replace Mac's Mouse and Keyboard with Speech

Move down! Move right! Double-click!

You've just told your Macintosh to open an application. And you didn't need to use the mouse. You did it by speaking into a microphone.

That's what the new Voice Navigator from Articulate Systems can let you do. After teaching the Voice Navigator a basic vocabulary of commands, you can run applications and perform complex operations entirely by voice.

Voice Navigator consists of a hardware/software combination that includes an A/D converter and voice recognition software. The hardware is contained in a 9-inch-square box that plugs into the Mac's SCSI port.

The system comes with a built-in microphone, speaker, and sound controls, and it can also be used with virtually any external microphone/headset combination. On the software side, the Voice Navigator can be used as a desk accessory or INIT file so that voice control is always available.

You can control the mouse cursor or any command in any application using the Voice Navigator—to control a HyperCard Japanese "language lab" application, for example. The Voice Navigator can also be used with Apple's MacroMaker.

A telecommunications option for later introduction involves a modem control so you can call up your Mac and tell it what to do.

Price: \$999.

Contact: Articulate Systems, Inc., 99 Erie St., Cambridge, MA 02139, (617) 876-5236.

Inquiry 1158.

continued

NEW!
Advanced Math
and Statistics
Applications Packs

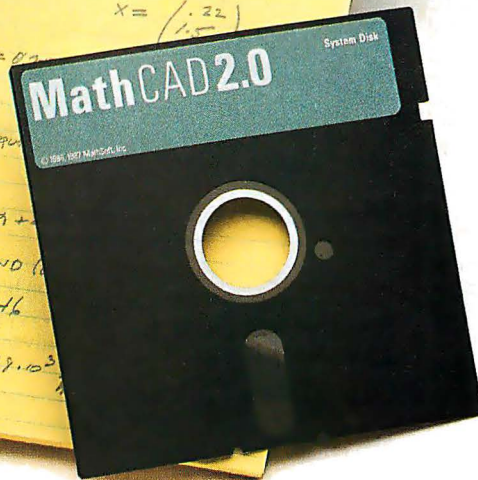
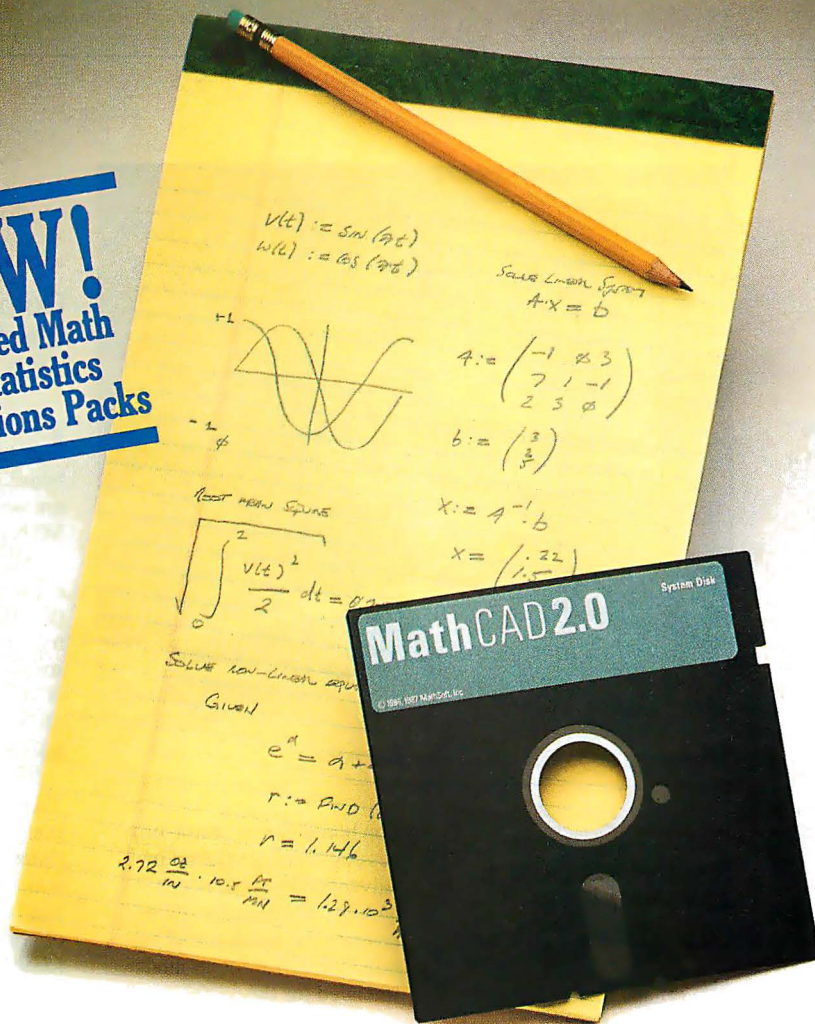

Your pad or ours?

If you perform calculations, the answer is obvious.

MathCAD 2.0.

It's everything you appreciate about working on a scratchpad—simple, free-form math—and more. More speed. More accuracy. More flexibility.

Just define your variables and enter your formulas anywhere on the screen. MathCAD formats your equations as they're typed. Instantly calculates the results. And displays them exactly as you're used to seeing them—in real math notation, as numbers, tables or graphs.

MathCAD is more than an equation solver. Like a scratchpad, it allows you to add

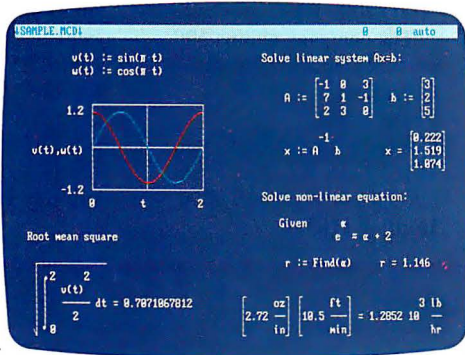

text anywhere to support your work, and see and record every step. You can try an unlimited number of what-ifs. And print your entire calculation as an integrated document that anyone can understand.

Plus, MathCAD is loaded with powerful

built-in features. In addition to the usual trigonometric and exponential functions, it includes built-in statistical functions, cubic splines, Fourier transforms, and more. It also handles complex numbers and unit conversions in a completely transparent way.

Yet, MathCAD is so easy to learn, you'll be using its full power an hour after you begin.

What more could you ask for? How about two new applications packs to increase your productivity?

The **Advanced Math Applications Pack** includes 16 applications like eigenvalues and eigenvectors of a symmetric matrix, solutions of differential equations, and polynomial least-squares fit.

The **Statistics Applications Pack** lets you perform 20 standard statistical routines such as multiple linear regression, combinations and permutations, finding the median, simulating a queue, frequency distributions, and much more.

MathCAD lets you perform calculations in a way that's faster, more natural, and less error-prone than the way you're doing them now—whether you use a calculator, a spreadsheet, or programs you write yourself. So come on over to MathCAD and join 45,000 enthusiastic users.

For more information, contact your dealer or call **1-800-MATHCAD** (In MA: 617-577-1017).

Requires IBM PC® or compatible, 512KB RAM, graphics card.
IBM PC® International Business Machines Corporation.
MathCAD® MathSoft, Inc.

MathCAD®

MathSoft, Inc., One Kendall Sq., Cambridge, MA 02139

Zoom to 4096 by 1792 Pixels

The second-generation Spectrum/8 video card for the Mac SE/30 provides a 1024-by-768-pixel display with pan and zoom features that allow you to see a part of the screen at a resolution of 4096 by 1792 pixels.

That resolution is designed with 1 bit of information corresponding to 1 pixel on the screen. At 2 bits per pixel, you can get up to four colors at a resolution of up to 2048 by 1792 pixels. At 4 bits per pixel, you rely on 16 colors and 2048 by 896 pixels. And at 8 bits per pixel, you get 256 colors and a resolution of 1024 by 896 pixels. Output can be color, gray-scale, or National Television System Committee-standard RGB.

The Mac SE/30 has an 030 Direct Slot connected directly to the 68030 microprocessor. The slot supports a 32-bit data and address bus and provides access to 32-bit ROM routines.

The Spectrum/8 will work with SuperMac, Apple, NEC MultiSync, and compatible monitors.

Price: \$1895.

Contact: SuperMac Technology, 485 Potrero Ave., Sunnyvale, CA 94086, (408) 245-2202.

Inquiry 1162.



The Spectrum/8 video card zooms and pans.

RasterOps Board Aims to Make QuickDraw Quicker

Perhaps the biggest criticism of the Macintosh II as a potential engineering workstation is its graphics performance. For this reason, RasterOps Corp. has introduced the ColorBoard 118, a graphics accelerator board that, according to the company, can run applications up to 60 times faster than standard QuickDraw. (QuickDraw is a toolbox of routines for drawing graphics primitives; it's driven by the Mac's 68020 processor.)

RasterOps' 8-bit accelera-

tion board uses a vector-processing chip, developed by Advanced Micro Devices (AMD), to intercept and accelerate the execution of certain QuickDraw commands intended for the 68020.

RasterOps' high-speed processing circuit, which incorporates the AMD chip, is called the Quad Pixel Data-flow Manager (QPDM). The company plans to implement it on its future boards using an AMD 2000 RISC processor.

The company claims 100 percent compatibility with QuickDraw.

Price: \$3195.

Contact: RasterOps Corp., 10161 Bubb Rd., Cupertino, CA 95014, (408) 446-4090.

Inquiry 1163.

Compaq Goes Beyond VGA with New Board

Compaq has introduced a high-resolution graphics board aimed at PC users who are not satisfied with IBM's VGA resolution.

The new Advanced Graphics 1024 Board, built around the 50-MHz Texas Instruments 34010 graphics processor, can display 16 colors out of a palette of 16 million at resolutions of up to 1024 by 768 pixels.

With special drivers, the 1024 boosts AutoCAD operations by as much as five times compared to a VGA system, Compaq claims. Compaq is working with a number of vendors to develop drivers for the new graphics system, including CADKEY, Evolution Computing, and Graphic Software Systems. The board will work with many high-resolution monitors.

An optional 512K-byte memory board adds the capability to display 256 colors simultaneously.

Price: \$1499; memory board, \$599.

Contact: Compaq Computer Corp., 20555 FM 149, P.O. Box 692000, Houston, TX 77269, (713) 370-0670.

Inquiry 1164.

continued

Dictate to Your 80386 with Dragon Systems' Board

DragonDictate is an AT-compatible board that turns your 80386-based system into a large-vocabulary dictation machine. And for the first time, Dragon Systems says, you don't have to be specially trained to use it.

DragonDictate is based on the DragonWriter speech recognition system. Even with a 5000-word vocabulary, DragonWriter lets you

dictate at near real-time rates.

The control and display interface is the key to its ease of use, Dragon Systems says. When a new word is spoken, the system relies on abbreviated keyboard entries to enter text. As it builds the acoustic models of the vocabulary, it shifts to real-time speech recognition to accelerate text entry. The in-

terface controls the display of most likely words from the dictionary and the active vocabulary. It also places the voice- or keyboard-selected word into the text of the document.

You need an 8-bit slot, a 1.2-megabyte 5¼-inch floppy disk drive, a 40-megabyte hard disk drive, 640K bytes of system RAM, a half-megabyte of expanded mem-

ory, and 4 megabytes of extended memory.

The board also comes with software, a headset microphone, and an instructional VHS videotape.

Price: DragonDictate, \$9000; DragonWriter, \$4500.

Contact: Dragon Systems, Inc., 90 Bridge St., Newton, MA 02158, (617) 965-5200. **Inquiry 1165.**

Pull out all the stops

Turbo C® Professional is the *only* production-quality C compiler with a completely integrated environment.

Everything you need—all the tools—are *included* in this environment, so you never waste time stopping, starting, and switching between tools.



And you're not forced into trade-offs between high-productivity programming and small, fast, reliable code. Instead you get the fastest and the best of both worlds.

There's tight integration between editor, compiler, linker, and debugger that lets you race through your program with a fast edit/compile/run/debug cycle.

Only Turbo C Professional gets it all together

Now everything you need to write *and debug* production-quality, optimized code in *both* C and

Assembly language is all yours in one package.

With Turbo C Professional you get:

- Turbo C 2.0 with its own integrated development environment—Compiler, Editor, Debugger, and Linker.
- Plus a separate command-line C Compiler
- Turbo Assembler®—a complete Macro Assembler that's more compatible with MASM than MASM is with itself.
- And the new source-level Turbo Debugger® that lets you debug *any size program*. Turbo C Professional has it all.

Turbo C 2.0

- Compiles over 16,000 lines per minute
- Hypertext online Help
- Supports inline assembly
- All six memory models supported
- More than 450 library functions

Turbo Assembler

- Assembles up to 48,000 lines per minute
- Compatible with MASM 4.0, 5.0, 5.1
- Full 386 support
- Assembles multiple files

Turbo Debugger

- Debug any size program
- Browse through structures with data debugging
- Set conditional breakpoints, break on memory access
- Stop, run code, log expressions
- 386 ICE capabilities



Turbo Debugger is a winner

Turbo Debugger won *PC Magazine's* most recent Award for Technical Excellence, and here's what they said:

"Everyone who's tried the Turbo Debugger agrees. It wins the (development tool) category's award for Technical Excellence hands down. The user interface is simple yet elegant; the program works the way programmers want to work. Yet again, Borland has advanced the state of the art in an eminently useful way."

Bill Machrone, Editor-in-Chief, *PC Magazine*

Debug any size program

Turbo Debugger lets you debug on a remote machine. That's a win. And in virtual mode of the 386, it allows you to debug *any size program*. Even your largest—*especially* your largest. That's a *huge* win.

And it can give you *12 different* views of your code. It supports browse-through data debugging; offers flexible breakpoints; supports in-circuit emulation; offers EMS support; has a "Point & Shoot" integrated debugging environment, and is completely CodeView® compatible. Turbo C Professional does all that, so *it* wins—and so do *you*.

Pull out all the stops

Turbo C's integrated environment lets you completely stop stopping. Your program is never interrupted. No stops and no g.aps. You compile faster. Link faster. Work faster. Think faster. So turn to Turbo C Professional: There's nothing stopping you now.

This is no ordinary Demo

Not one, not two, but three different demos on the same disk: Turbo C, Turbo Pascal,® and Turbo Debugger. We'll send you the demo disk and fact sheets with technical information for \$4.95. **To order, CALL (800) 345-2888 Ext. 200**



Turbo C, Turbo Pascal, Turbo Assembler, and Turbo Debugger are registered trademarks of Borland International. Copyright ©1989, Borland International, Inc. All right reserved. BI 1286

Code: MC01

B O R L A N D





Announcing a big leap in mouse technology.

Finally, a mouse with an extraordinary body and a mind to match.

A mouse ballistically tuned to accelerate your cursor across any screen with the mere flick of a wrist, and slow it down on arrival for pixel-point control on detail work.

This mouse is guaranteed to work with all applications on your IBM personal computer. And it comes with a great selection of MouseWare™ including Pop-Up DOS™—the ultimate DOS handler; Mouse-2-3™, the Lotus 1-2-3™ shell; and 35 menus for best-selling keyboard-based applications.

The Logitech Mouse. \$139, complete with Logitech's Lifetime Satisfaction Guarantee and unlimited Product Support.

For your nearest dealer, call:

800-231-7717

*In California:
800-552-8885*

*In Europe:
++ 41-21-869-96-56*

*Circle 311 on Reader Service Card
(DEALERS: 312)*



Plastic Optical-Fiber LAN Eases Installation Hassles

The Fiberstar PC network, the first commercially available plastic optical-fiber LAN, couples the installation ease of twisted-pair cabling with some of the communications advantages normally associated with glass optical fiber.

This takes plastic optical fiber beyond the realm of illumination of automotive instrumentation and into the office. At about \$1000 per node, the 2-Mbps Fiberstar PC network makes plastic fiber a cost-effective alternative to twisted-pair copper wiring for local-area networking all the way to the desktop. And it brings with it glass fiber's often-touted advantage of immunity to electromagnetic interference.

Installation hassles are almost nonexistent with the Fiberstar PC LAN. This is because the Mitsubishi Rayon-manufactured optical fiber that Netronix uses is roughly 16 times the diameter of the glass optical fiber used in LANs. The plastic fiber is also less expensive and tougher than glass, which cannot be wound tighter than about a foot in diameter without degrading the signal or breaking the glass.

Installing and terminating glass optical fiber has always been the domain of telephone company technicians, who are said to use the expertise of an electrician and the precision and instruments of a jewel cutter. The plastic optical fiber used here, however, can easily be installed by the average office worker.

There's no need to polish the end of plastic fiber, and the plastic connector (by Amp, Inc.) simply snaps into its place on the XT-compatible add-in cards in your computer

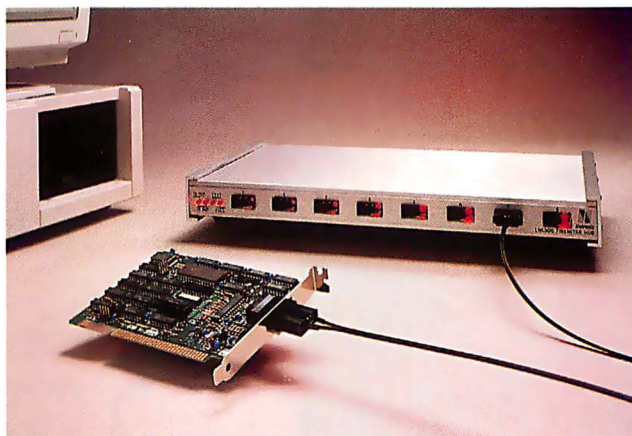

Fiberstar, the plastic optical-fiber LAN from Netronix.

and on the Netronix networking hub.

Each add-in card includes a 650-nanometer LED source and a positive-intrinsic-negative photodiode receiver. Optional cards conform to the TCP/IP.

The 16-port Fiberstar active hub is configured with 650-nm LEDs for plastic optical-fiber transmission distances of up to 500 feet, with 850-nm LEDs for glass optical fiber for transmission up to 5000 feet, or with combinations of different LEDs for the different media. (Active hubs have repeaters; passive hubs simply switch the signals.) In a star configuration, multiple hubs can support up to 240 nodes.

Through Netronix bridges and broadband adapters, Fiberstar PC hubs can hook into standard baseband networks like Ethernet and StarLAN, and into standard broadband networks as well.

Price: Card, \$595; card with TCP/IP package, \$895; 16-port hub, \$2195.

Contact: Netronix, 1372 North McDowell Blvd., Petaluma, CA 94952, (707) 762-2703.

Inquiry 1159.

Sync Your PC with Telecommunications

The Network Access Controller from Sync Research gives many types of terminals a 64-kbps clear channel for data transfer. Standard support is available for PC and other asynchronous (including asynchronous X.29 hosts) and synchronous devices. A 3270 emulator is included to allow your PC to emulate 3270 terminals, both bisynchronous and System Network Architecture. (SNA is the set of specifications governing IBM networks; it's analogous to the Open Systems Interconnection reference model.)

About the only networking protocol left is TCP/IP, commonly used for Ethernet LANs, and Sync Research says that it plans to upgrade the Network Access Controller for TCP/IP functionality next.

The 64-kbps channel is possible through the X.25-standard packet-switched network.

The enabling device within the controller is a packet assembler/disassembler (PAD) that assembles packets of data for transmission with other packets on the X.25 telecommunications infrastructure. (Voice is carried through the same infrastructure but is not compressed into packets.)

Unlike the PAD modem

recently introduced by Hayes, the Network Access Controller works only with leased telecommunications lines, not with dial-up, circuit-switched lines. That means you must lease the line from your telephone company at a premium price. But because you'll own that connection, there's no need to dial a number, and you'll never get the standard holiday message, "All circuits are busy; please try your call again."

Each Network Access Controller supports up to eight simultaneous sessions per terminal, and the standard Network Access Controller has four terminal ports. A separate control unit (available from several vendors) gives you multidrop capabilities with bisynchronous and SNA terminals for as many as 32 terminals per session. Based on the number of sessions and the multidrop capabilities, a Sync Research spokesperson estimated that between 40 and 100 people will use a single Network Access Controller simultaneously.

To tie it all together, you'll need to add network management hardware and software from Sync Research.

The network management hardware consists of an 80286-based machine with 2 megabytes of RAM, a 71-megabyte hard disk drive, a port for Sync's proprietary AT-compatible communications board, and an asynchronous terminal. The 80286-based machine runs Xenix and the Sync software.

Price: \$5880; four-port expansion, \$2500 each; network management hardware, \$12,500; software, including Xenix, \$16,240.

Contact: Sync Research, 13891 Newport Ave., Tustin, CA 92680, (714) 669-8020.

Inquiry 1160.

continued

More power to the people.

ORACLE
5.1B

ORACLE has led a revolution in PC relational database technology. More power. More portability. More connectivity. More reasons than ever to make ORACLE your corporate standard database.



New tools with even more power.

We're proud to announce our newest release—Professional ORACLE Version 5.1B. Now you can run your applications in OS/2 or in protected mode above 640K in MS-DOS. So you have more room for more powerful applications. And those same applications run unmodified on almost all workstations, minicomputers and mainframes.

Version 5.1B delivers a new level of power to your PC developers including the latest versions of:

- SQL*Forms® NEW! Enhanced 4th-generation application development environment.
- SQL*Menu® NEW! Flexible interface builder for defining complex menu systems.

• SQL*ReportWriter™ NEW! Non-procedural development and runtime powerhouse for producing any report.

• SQL*Plus® Oracle's ANSI-standard SQL query and administration tool.

• Pro*C™ The C-language pre-compiler and subroutine call interface to ORACLE.

Learn SQL on us.

Learn the language of the revolution. Order Professional ORACLE today for \$1299 and we'll include ORACLE SQL*Tutor, a nine-module PC-based SQL instruction program that sells by itself for \$199.

Try ORACLE for \$199.

Our Trial Version is identical to Professional ORACLE, but can't be used in networked configurations and allows a maximum user database size of 1 MB. It's a powerful tool for prototyping your first ORACLE application. And its price can be applied to the purchase of a full Professional ORACLE license.

ORACLE®
COMPATIBILITY • PORTABILITY • CONNECTABILITY
Call 1-800-ORACLE1, ext. 4931 today.

Money-back guarantee.

If you haven't tried ORACLE yet, now there's even more reason to join the SQL revolution. More tools. More power. If ORACLE 5.1B doesn't revolutionize the way you develop PC database applications, return it within 30 days for a full refund.

Call 1-800-ORACLE1 ext. 4931, or an ORACLE MasterVAR today.

Dear Oracle

Oracle Direct • 20 Davis Dr. • Belmont, CA 94002
1-800-ORACLE1, ext. 4931

Since your 30-day money-back guarantee eliminates any risk on my part, please send me the software below. Enclosed is my check, or VISA MasterCard AmEx credit card authorization. Offer valid only in the USA. Please send 5.25" High Density or 3.5" disks.

- Professional ORACLE for MS-DOS with free ORACLE SQL*Tutor for \$1299 \$ _____
- Professional ORACLE for MS-DOS Trial Version for \$199 \$ _____
- Professional ORACLE for OS/2 For \$1299 \$ _____

Professional ORACLE Requirements: MS-DOS—80286/80386 PC with MS-DOS V3.1+, hard disk, 640KB of memory and 896K extended memory required. 2.5MB of extended memory recommended (required for SQL*ReportWriter). OS/2—80286/80386PC w/ OS/2 V1.0, hard disk, 3MB memory. SQL*ReportWriter not available for OS/2 and is replaced by SQL*Report®.

- Just send ORACLE SQL*Tutor for \$199 \$ _____
- Minimum Requirements: 256K PC with hard disk. Color monitor suggested.

Subtotal \$ _____
Please add appropriate sales tax \$ _____
Total enclosed/authorized (USA only) \$ _____

NAME _____ TITLE _____
COMPANY _____
STREET (no PO boxes, please) _____
CITY _____ STATE _____ ZIP _____
PHONE _____
CREDIT CARD NO _____ CARD EXPIRATION DATE _____
SIGNATURE _____ TODAY'S DATE _____ **BYTE.MAG**

IC Programmer Expanded for Logic Devices

The JE680 Universal IC Programmer is an EPROM programmer that has been upgraded to program many types of logic and memory-type programmable devices, with or without computer support. Now it can also program memory devices such as MOS/CMOS EPROMs, MOS/CMOS EEPROMs, PROMs, and bipolar PROMs. It will also program programmable-array-logic devices.

The computer interface is RS-232C. There's a parallel printer port, and the JE680 supports standard, intelligent, and quick-pulse programming methods.

A pin-check function with pulse-reflection technology lets you examine individual pins. You can use up to 18 data formats, and the JE680 is compatible with many of the software packages written for other EPROM programmers. Or you can use the software option package—including Boolean conversion, auto-compiling, and fuse map generation—for logic design applications.

After programming, you can use the JE680 to do an automatic self-test, an insertion and backward-device check, and other test functions.

Price: \$1799.95; software, \$29.95.
Contact: Jameco Electronics, 1355 Shoreway Rd., Belmont, CA 94002, (415) 592-8097.

Inquiry 1166.



The JE680 Universal IC Programmer works for memory and logic devices.

EPROM Eraser Shields You from Shortwave UV Light

The EE128 EPROM Eraser uses a 4-watt, 254-nanometer ultraviolet light source to erase up to nine EPROMs in less than 30 minutes. But you won't get any UV exposure with the snaplock drawer and safety switch that help block the escape paths for these harmful rays. There's even a lamp-on indicator for extra protection.

Price: \$79.95.

Contact: Ultra-Lum, Inc., 217 East Star of India Lane, Carson, CA 90746, (213) 324-2247.

Inquiry 1167.

Firmware Prototyping Made Easy

The Analogica-T is a software and hardware development tool designed for prototyping computer control interfaces to scientific instruments and industrial equipment. It looks like a full-length board for your PC (it's XT or AT compatible) and a hardware design unit that's just about the length and width of your briefcase.

An 8255-A provides 24 lines of parallel I/O, and switching allows address selections as required for such things as direct memory access and serial I/O.

Circuitry is mostly wire-wrap, Westcoast Technical & Hobby says, so you can make custom modifications. It also lowers the price for using printed circuit boards with copper on only the top and bottom layers.

Driver software is supplied in .EXE and .ASM formats on a 5 1/4-inch floppy disk drive. Executable 8088 code and an 8255-A driver are also included, as are source code skeletons.

The design board includes buffered system signals brought to terminal strips adjacent to four solderless breadboards.

Each kit comes with assembly instructions and schematics for installation in about 30 hours, depending on the options.

Price: \$721; assembled and tested, \$1203.

Contact: Westcoast Technical & Hobby, P.O. Box F110-415, Blaine, WA 98230; or call the headquarters in Surrey, BC, Canada at (604) 591-1624.

Inquiry 1168.

Mac Digitizing System Works in 3-D

Forget mice; forget touch panels. At the MacWorld Expo, Mira Imaging introduced a digitizing system that uses three dimensions. The new HyperSpace system consists of a small table that can detect the position of a pen-like stylus in three-dimensional space. Company representatives demonstrated the system by digitizing a bust of an Egyptian pharaoh.

You place the stylus on a point on the surface of the bust and then press the mouse button. A group of electromagnetic sensors located in a small table under the bust then determines where the stylus is located and passes the information to the Macintosh.

Once a sufficient number of points is determined, the System software can then group the points into triangular planes to create a surface. The software can then soften this jagged surface into a smoother one. Once the surface has been generated, you can shade the surface and change the angle of lighting by moving the stylus.

The company claims that the system has a resolution of 0.03 inch at a distance of 15 inches. As expected, the resolution gets worse with increasing distance. In addition to the x, y, and z coordinates of the stylus, the system can also measure its pitch, yaw, and roll. Because it uses electromagnetic waves, the HyperSpace system can be used only with nonmetallic models.

Price: \$5300.

Contact: Mira Imaging, Inc., 969 Logan Ave., Salt Lake City, UT 84105, (801) 485-6765.

Inquiry 1169.

continued

We'll never try to sell you a laser printer.

We will, however, try to sell you on a laser printer language.

The PostScript® language from Adobe Systems.

You see, there are two kinds of printers and typesetters in the world. Those that support PostScript. And those that do not.

The ones that do—at last count there were 46—are completely compatible. That means, when you print a file on a PostScript printer from one manufacturer, you can print the same



file on a PostScript typesetter from a completely different manufacturer. And that's good to know, since more than 25 different O.E.M.'s have adopted the Adobe PostScript language.

On the other hand, when you print a file on a printer that doesn't support PostScript, that's virtually the only place you can print it. Forever.

Since there are so many different PostScript printers and typesetters, you can pick the one that

meets your specific needs. For paper handling options. Printing speeds. Choice of resolutions. And black & white or color output.

And only Adobe PostScript gives you absolute freedom to select the best hardware and more than 3,000 software programs for virtually every application, platform and budget.

Isn't it time you bought into the PostScript language?





*Introducing the new small footprint
FlexCache Z-Series.
For fruitful comparisons.*

	\$2699.00		\$3799.00		\$5199.00	
Models	ALR® FlexCache SX386-Mod.10	Compaq® Deskpro 286 - Mod.10	ALR® FlexCache 20386Z-Mod.10	Compaq® Deskpro 386S-Mod.10	ALR® FlexCache 25386Z-Mod.10	Compaq® Deskpro 20e - Mod.10
Microprocessor	80386SX 16MHz 16KB, 82385 Cache	80286 12MHz 1 wait state	80386 20MHz 64KB, EE 82385 Cache	80386sx 16MHz	80386 25MHz 64KB, EE 82385 Cache	80386 20MHz 32KB Cache
Bench Mark*	3.36Mips	1.93 Mips	4.78 Mips	2.49Mips	6.07 Mips	4.60Mips
Cpt. Math. Coprocessor	80387SX 16MHz	80287 12MHz	80387, Weitek	80387sx	80387, Weitek	80387, Weitek
Memory (RAM)	1MB <small>Expandable to 16MB</small>	640K <small>Expandable to 8MB</small>	1MB <small>Expandable to 16MB</small>	1MB <small>Expandable to 13MB</small>	1MB <small>Expandable to 16MB</small>	1MB <small>Expandable to 16MB</small>
Storage	1 Optional (\$225.00) 40MB<35ms 40MB<28ms	Optional (\$275.00) 1 40MB<30ms	1 Optional (\$225.00) 40MB<35ms 120MB<28ms	Optional (\$275.00) 1 20MB<29ms 40MB<30ms	1 Optional (\$225.00) 40MB<35ms 120MB<28ms	Optional (\$275.00) 1 40MB<30ms 110MB<29ms
Fixed Disk Opt.						
Video	16 bit VGA 800 X 600		16 bit VGA 800 X 600	VGA 640 X 480	16 bit VGA 800 X 600	VGA 640 X 480

* Data Base Power Meter Ver. 1.5

Prices and specifications are subject to change. Verify with manufacturer.



*Award
Winning
FlexCache
Architecture.*

*With ALR's
award winning
design, the Z-Series
incorporates the
most advanced form
of cache management.*

Compaq and Compaq Deskpro 286, 386s and 20e are registered trademarks of Compaq Computer Corp. PC-kwik is a registered trademark of Multisoft Corp. Deskview 386 is a registered trademark of Quarterdeck Office Systems.

It's a fruitless comparison when ALR is the obvious choice.

ALR FlexCache SX386Z



No one compares with our three year warranty.



ALR's quality is backed by an unprecedented three year warranty on all main CPU boards and a full one year warranty on entire systems. We also offer extended warranty programs and on-site servicing.

And there's comparably more.

Each system includes PC-Kwik®. The disk caching

utility voted PC Magazine's Editor's Choice.

In addition, Info World's product of the year, DESQview 386®, the powerful multitasking and windowing program is included with the FlexCache Z systems until May 31, 1989.

For more information on the FlexCache Z-Series or the

ALR FlexCache 25386Z



ALR FlexCache 20386Z

name of your local authorized ALR reseller please call:

1-800-444-4ALR



Advanced Logic Research, Inc.
9401 Jeronimo, Irvine, CA 92718
(714) 581-6770 FAX:(714) 581-9240

For our Canadian office: 1-800-443-4CAN
For our UK office: 1-800-444-4ALR
For our Singapore-Asia/Pacific office:
(65) 258-1286 FAX: (65) 258-1285

See us at
COMDEX Spring '89
April 10-13, 1989
McCormick Place
Chicago, Illinois

FORTRAN Text Editor for the Mac

Developing FORTRAN codes and models on the Macintosh has been difficult in the past due to the cumbersome editors. FREDitor is a text editor with the standard features along with some special functions, such as multiple windows, global regular-expression parser (GREP) search and replace, custom auto-wrap, on-screen column markers, and the ability to generate tables for export to spreadsheets.

FREDitor was developed at Battelle's Pacific Northwest Laboratories and is being published and marketed by TechAlliance (formerly A.P.P.L.E. Co-op).

FREDitor runs on any Macintosh, according to TechAlliance.

Price: \$79.95.

Contact: TechAlliance, 290 Southwest 43rd St., Renton, WA 98055, (206) 251-5222.

Inquiry 1121.

Modula-2 on the Mac

The MetCom Modula-2 integrated programming environment for the Mac includes a multiwindow text editor, a one-pass compiler, and an interactive debugger.

The MetCom Editor uses information from the compiler to show various positions in the source program where syntactic errors occur. You can also shift blocks of text, indent text as you enter it, or display windows as tiles or stacks. You can open multiple windows and handle files of any size.

The one-pass compiler generates native code for the

Graphics Software Engineering

Using the MetaWindow graphics driver from MetaGraphics, Turbo Meta-Menu provides a user interface for any graphics application program with Turbo Pascal versions 4 and 5. You can create menus, pop-up messages, button menus, and more.

The Turbo Meta-Menu utilities package consists of a library with over 70 procedures that help you create menus. Two additional pro-

grams are also included: CurEdit is an icon editor, and MakeMenu is a Turbo Pascal code generator.

To run the program, you need MetaWindow graphics, an IBM PC with a video graphics adapter, a mouse, and a hard disk drive.

Price: \$149; MetaWindow, \$95; source code, \$75.

Contact: Island Systems, 7 Mountain Rd., Burlington, MA 01803, (617) 273-0421.

Inquiry 1120.

68000/68020 processors, and the code needs no explicit linking, according to the manufacturer. Each compilation produces two files: an object file used by the linker for execution, and a reference file used by the source-level debugger. A dialog box also lets you know how the compilation process is going.

You can view the execution environment at run time with the Runtime Examiner. If an error occurs, the debugger is called and displays several windows that show the source statements being executed, the modules and procedures called, and the values of module and procedure variables, as well as the addresses of the various loaded modules.

A variety of libraries and Macintosh interface modules is included with the program.

MetCom Modula-2 runs on the Mac Plus, SE, and II with System version 4.1 or higher and two 800K-byte floppy disk drives. A hard disk drive is recommended but not required.

Price: \$245.

Contact: Metropolis Computer Networks, Inc., The Trimex Building, Route 11,

Mooers, NY 12958, (514) 866-4776.

Inquiry 1124.

Adding Graphics to Unix the Convenient Way

The Convenience Plus Unix front end is a graphical interface for Unix from SoftScience. The program lets you perform file management, operating-system commands, and other administrative functions. It offers you a graphical tree display of your stored files, which you can traverse with arrow keys or a mouse.

You can call up windows to display and interact with a graphical image of file storage. The window can also list files or running applications. Other features include a hexadecimal editor/viewer, a search function, and utilities for manipulating files in groups or individually. You can also move files across directories, and you can create and delete directories with the interface.

The program is compatible with Sun, AT&T, and other Unix systems.

Price: \$399.

Contact: SoftScience Corp., P.O. Box 42905, Tucson, AZ 85733, (602) 326-4679.

Inquiry 1122.

Forth in the Public Domain

To encourage programmers to use Forth to develop large applications, the Silicon Valley Chapter of the Forth Interest Group has donated F-PC 2.25 to the public domain. The Forth development environment is derived from F83, an earlier public domain version of Forth.

F-PC 2.25 comes on four 360K-byte disks with most files archived. The object code takes 400K bytes of RAM, while the source code and documentation take up about 3 megabytes of disk space.

Some of the features offered by F-PC 2.25 include a command-line interpreter, a high-level procedure compiler/decompiler, an 8086/87 assembler/disassembler, a multitasker, a single-step debugger, core image dump, source code listing and indexing, text searching through files, a turnkey application generator, and a meta-compiler for system regeneration. A collection of applications includes floating-point packages, object-oriented procedures, databases, graphics, mathematics, games, music programs, and more.

The program runs on the IBM PC. A graphics card and hard disk drive are recommended.

Price: \$25; user's manual, \$20; technical reference manual, \$30.

Contact: Offete Enterprises, Inc., 1306 South B St., San Mateo, CA 94402, (415) 574-8250.

Inquiry 1123.

continued



INSTANT MAINFRAME. JUST ADD SCO.

Not too long ago, a few dozen people sharing the same programs, resources, and information on a single computer at the same time meant only one thing—a mainframe.

Powerful, big, expensive, and proprietary.

More recently, the same people could be found doing exactly the same things—simultaneously sharing programs, resources, and information—on a minicomputer.

A lot cheaper, a lot smaller, yet powerful enough to do the same jobs. And just as proprietary.

Then along came the latest generation of personal computers. And now, the same people are more and more likely to be found doing exactly the same things—simultaneously sharing programs, resources, and information—on a PC.

And not a whole officeful of PCs networked together, either, but *a single PC powering the whole office at once.*

A lot cheaper, a lot smaller, yet still easily powerful enough to do the same jobs. Built to non-proprietary, open system standards that allow complete freedom of choice in hardware and software.

And running the industry-choice multiuser, multitasking UNIX® System V platform that gives millions of 286- and 386-based PC users mainframe power every business day.

The UNIX System standard for PCs—SCO.™

See us at COMDEX/Spring '89, Booth #2850

Today, SCO UNIX System solutions are installed on more than one in ten of all leading 386 computers in operation worldwide. Running thousands of off-the-shelf XENIX® and UNIX System-based applications on powerful standard business systems supporting 32 or even more workstations—at an unbelievably low cost per user. And with such blazing performance that individual users believe they have the whole system to themselves.

Running electronic mail across the office—or around the world—in seconds.

Running multiuser PC communications to minis and mainframes through TCP/IP and SNA networks.

And doing some things that no mainframe—or even DOS- or AOS/2™-based PC—ever thought about, such as running multiple DOS applications. Or networking DOS, OS/2, XENIX and UNIX Systems together. Or running UNIX System versions and workalikes of popular DOS applications such as Microsoft® Word, 1-2-3®, and dBASE III PLUS.®

Or even letting users integrate full-featured multiuser productivity packages of *their choice* under a standard, friendly menu interface.

Today's personal computer isn't just a "PC" anymore, and you can unleash its incredible mainframe-plus power for yourself—today.

Just add SCO.

The SCO family of UNIX System software solutions is available for all 80286- and 80386-based industry-standard and Micro Channel™ computers.

UNIX is a registered trademark of AT&T. SCO and the SCO Logo are trademarks of The Santa Cruz Operation, Inc. Microsoft and XENIX are registered trademarks of Microsoft Corporation. OS/2 and Micro Channel are trademarks of International Business Machines Corporation. 1-2-3 is a registered trademark of Lotus Development Corporation. dBASE III PLUS is a registered trademark of Ashton-Tate.
 ©1989 The Santa Cruz Operation, Inc., 400 Encinal Street, P.O. Box 1900, Santa Cruz, California 95061 USA
 The Santa Cruz Operation, Ltd., Croxley Centre, Hammers Lane, Watford WD1 8YN, United Kingdom, +44 (0)923 816344. FAX: +44 (0)923 817781. TELEXC: 917372 250000



(800) 626-UNIX (626-8649)

(408) 425-7222

FAX: (408) 458-4227

E-MAIL: ...!uunet!sco!info info@sco.COM

Digital Signal Processing

PC Data Master, a DOS environment for signal processing and display, has been enhanced with separately compiled modules for systems with and without a math coprocessor, a multisignal plot utility, and an enhanced DOS shell.

The program combines graphics routines, real- and complex-data-file math routines, digital signal processing utilities, test-data generation routines, data sampling routines, and binary data pipes to create a DOS-based DSP system.

Most graphics boards are supported, and you can integrate data-analysis functions into the program using most compilers or assemblers compatible with DOS 2.0 or higher.

The shell that is at the heart of PC Data Master lets you implement independent DOS console and graphics screen windows. When the shell is active, you can interact with DOS application routines in the console window without disturbing screen graphics, according to the manufacturer. The shell also provides binary data pipes for linking data-processing steps, implemented as independent executable files into multistage data transformations. The pipes are distinct from the DOS pipes and don't affect the standard input and output logical devices, according to Durham Technical Images.

A waveform module is also included with PC Data Master. You can display individual or multiple data files using the plot system's auto-configuration capabilities. You can use pop-up menus and forms, and you can adjust each plot on the display for size, place-

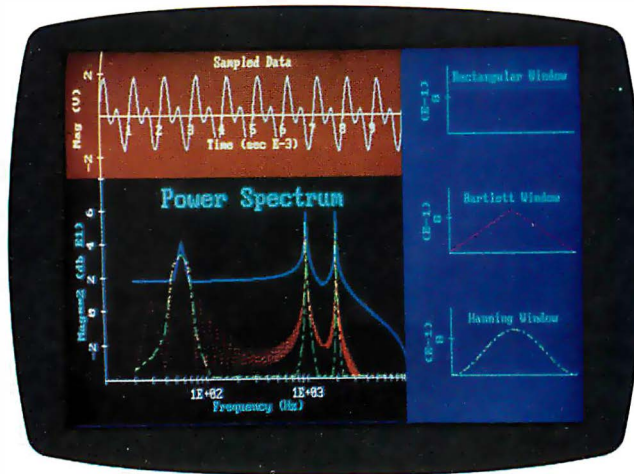

PC Data Master 2.0 is an enhanced DOS environment for signal processing and display.

ment, colors, titles, labels, assignment of data files and channels to axes, and more. You can also store display templates with display designs, and you can print hard copies of data displays in portrait and landscape orientation using dot-matrix or laser printers.

Version 2.0 comes with an augmented set of DSP utility modules. Operations include forward and inverse fast-Fourier-transform and fast-Hartley-transform routines, convolution, correlation, window generation, FIR filter design, and test-data generation.

You can implement many multistage transformations by combining these basic operations with data-file math routines in data pipes, according to Durham Technical Images. Data acquisition modules for MetraByte analog input products are also included, and you can integrate routines for other analog I/O products.

PC Data Master 2.0 runs on the IBM PC with 256K bytes of RAM and DOS 2.0 or higher. A hard disk drive and a math coprocessor are recommended. Shells are provided for CGA, Hercules, AT&T, EGA, and VGA graphics.

Price: \$135.

Contact: Durham Technical Images, P.O. Box 72, Durham, NH 03824, (603) 868-5774.

Inquiry 1126.

Stats Packs Added to MathCAD

Two recently released application packs for MathCAD 2.0 cover tests and estimation, and modeling and simulation, respectively. MathCAD lets you use a PC like a scratch pad, according to MathSoft. You can enter and

calculate equations, create plots, and enter and edit text. The program also lets you integrate math, text, and graphics on- and off-screen.

The Tests and Estimation pack lets you implement standard test procedures, create your own test procedure, simulate experiments, and model data from within your MathCAD document. A set of standard routines including parametric and nonparametric techniques is included.

The Modeling and Simulation pack includes techniques for modeling data and carrying out simple Monte Carlo simulations. Each pack contains 16 standard procedures.

These application packs are the second and third in a series for use with MathCAD. The first in the series was the Advanced Math Applications Pack. You can purchase the packs separately or bundled together with MathCAD 2.0.

MathCAD 2.0 runs on the IBM PC with at least 512K bytes of RAM and DOS 2.0 or higher. The company recommends a math coprocessor.

Price: Statistics I: Tests and Estimation, \$59; Statistics II: Modeling and Simulation, \$69; I and II, \$99; MathCAD 2.0, \$349.

Contact: MathSoft, Inc., One Kendall Sq., Cambridge, MA 02139, (800) 628-4223; in Massachusetts, (617) 577-1017.

Inquiry 1128.

continued

Building Chemical Structures on the Mac

Chemists involved in searching STN International's chemical structure database may find that ChemConnection simplifies the process of constructing a chemical structure. You can draw a query structure offline using the same drawing

capabilities as in the ChemIntosh Desk Accessory, according to SoftShell. You also don't need to know all the structure-generation commands used by the Chemical Abstracts Service, SoftShell reports.

ChemConnection runs on

the Macintosh with at least 1 megabyte of RAM and a hard disk drive.

Price: \$395.

Contact: SoftShell International, Ltd., 2004 North 12th St., Grand Junction, CO 81501, (303) 242-7502.

Inquiry 1125.

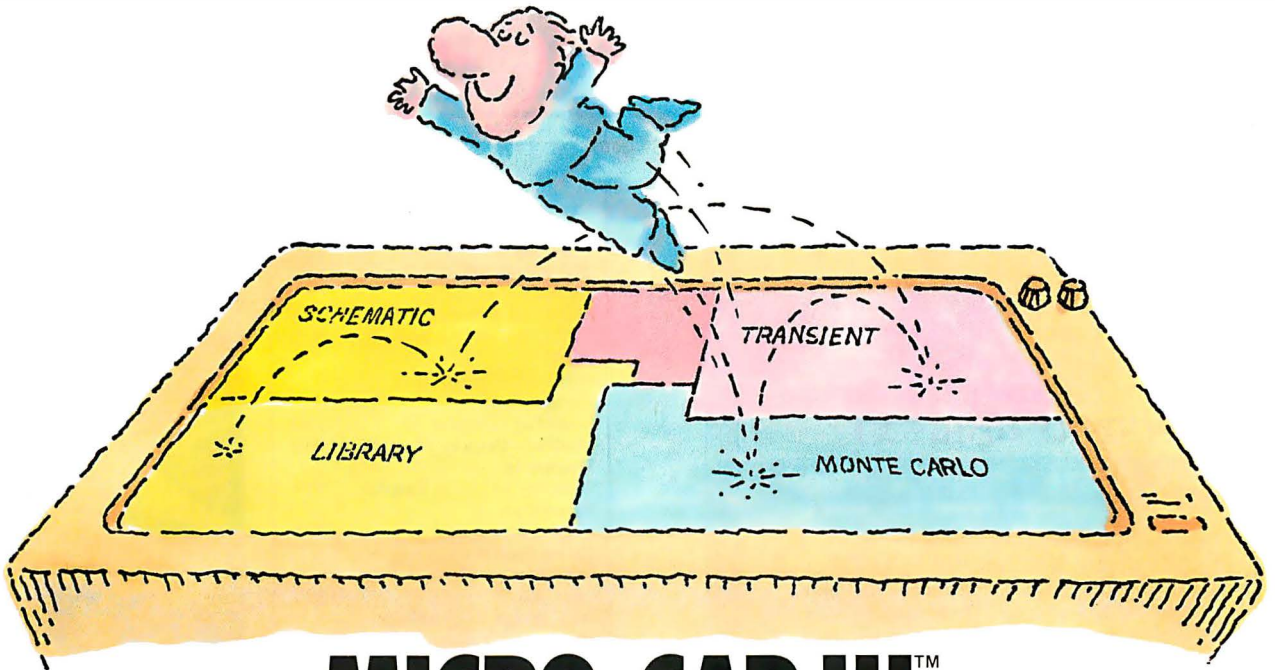

MICRO-CAP III.TM THIRD-GENERATION INTERACTIVE CIRCUIT ANALYSIS. MORE POWER. MORE SPEED. LESS WORK.

MICRO-CAP III,TM the third generation of the top selling IBM® PC-based interactive CAE tool, adds even more accuracy, speed, and simplicity to circuit design and simulation.

The program's window-based operation and schematic editor make circuit creation a breeze. And super-fast SPICE-like routines mean quick AC, DC, Fourier and transient analysis — right from schematics. You can combine simulations of digital and analog circuits via integrated switch models and macros. And, using stepped component values, rapidly generate multiple plots to fine-tune your circuits.

We've added routines for noise, impedance and conductance — even Monte Carlo routines for statistical analysis of production yield. Plus algebraic formula parsers for plotting almost any desired function.

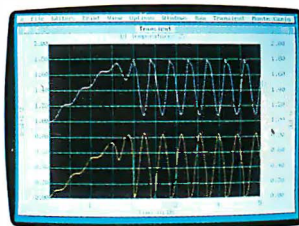

Transient analysis

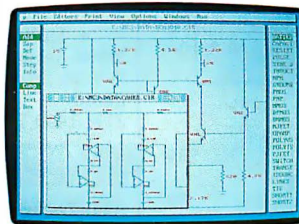

Schematic editor

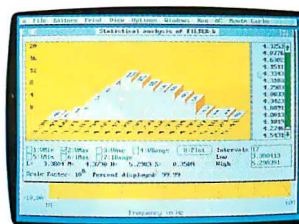

Monte Carlo analysis

Modeling power leaps upward as well, to Gummel-Poon BJT and Level 3 MOS — supported, of course, by a built-in Parameter Estimation Program and extended standard parts library.

There's support for Hercules® CGA, MCGA, EGA and VGA displays. Output for laser plotters and printers. And a lot more.

The cost? Just \$1495. Evaluation versions are only \$150.

Naturally, you'll want to call or write for a free brochure and demo disk.

Spectrum

1021 S. Wolfe Road,
Sunnyvale, CA 94086
(408) 738-4387

MICRO-CAP III is a registered trademark of Spectrum Software.
Hercules is a registered trademark of Hercules Computer Technology.
IBM is a registered trademark of International Business Machines, Inc.

CMO...Your Nationwide Source



PC-TOO 10MHz XT®

BASIC SYSTEM CONFIGURATION:

- 8088-10 Based System Board
- 4.77/10 MHz CPU Speed
- 640KB RAM Standard Expandable to 1640K
- 3-In-1 Video Adapter - RGB, Mono, Comp.
- Microsoft MS-DOS & GW-BASIC Included
- Real Time Clock Calendar
- System Reset Switch
- Floppy Disk Drive Controller
- 360K Floppy Drive
- 4 Half-Height Peripheral Slots
- 8 Expansion Slots
- 102-Key Enhanced Keyboard
- Parallel/Serial/Game Ports
- 150 Watt Power Supply
- Amber Monochrome Monitor

\$699

Call For Information On Other
PC-TOO's (10 AT & 20MG 386)

AMIGA

Aegis Development	
Draw Plus 2000	\$159
Lights, Camera, Action	59
Videoscape 3D	139
Cinemaware	
TV Sports	36
Electronic Arts	
Deluxe Paint II	99
Photo Lab	99
Epyx Software	
XJ-500 Joystick	15
Gold Disk Software	
Professional Draw	139
Lattice	
Lattice C 5.0	199
Micro Systems Int.	
Raw Copy V1.3	44
Micro Systems Software	
The Works Platinum	189
New Tek Inc.	
Digi-View Gold	149
Digi-Paint	44

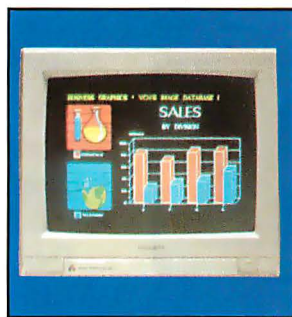

MAGNAVOX
CM8762 14" Comp./RGB
\$239

Sub-Logic Corp.	
Flight Simulator II	\$39
WordPerfect Corp.	
WordPerfect	189

MACINTOSH

Olympia	
NP-30 Mac 150cps	\$289
Seikosha	
SP-100CAP Mac	239
Everex	
EMAC 20 Deluxe 20MB	595
EMAC 60T 60MB Backup	895
PCPC	
45MB SCSI Hard Drive	999
Cornerstone	
SinglePage Display SE	759
DualPage Display SE	1259
Magnavox	
9CM080 14" VGA Display	519
RasterOps	
19485 Trinitron	3395
Sigma Designs	
PageView SE	849
LaserView II	1899
New Image Technology	
MacScan Pro Sheetfeed	1399
MacScan Pro Flatbed	1789
Practical Peripherals	
Mac 2400 Stand Alone	239
Shiva	
NetModem V2400	459

MONITORS

Amdek	
Video 210 Amber	85
Video 410 TTL Monochrome	145
Video 432 VGA Monochrome	169
Color 732 VGA Color	399
Cornerstone	
SinglePage Display	899
Magnavox	
7BM623 12" TTL Amber	89
9CM053 14" HiRes EGA	369
9CM062 14" VGA Display	349
9CM082 14" VGA Display	399
NEC	
JC-1403 Multisync IIA	539
Packard Bell	
PB-1272 12" TTL Mono	79
PB-1472 14" TTL 132 Col.	109
PB-1422EG 14" HiRes EGA	359
Polaroid	
Palette EGA Plus	2299
Seiko Instruments	
CM-1430 14" VGA	639
Taxan	
119 12" Composite Amber Mono.	89
770+ MultiVision Display	499
Wyse Terminals	
WY-30, 50, 60	Call
Zenith	
ZFM-1490 14" VGA Analog	619

MULTIFUNCTION

ATD-ZuckerBoard	
Color Half Card	79
Monochrome Graphics Adpt.	79

AST

Six Pak Plus Board	\$149
VGA Plus Adapter	389
Boca Research	
TopHat 128K Expansion	129
BocaRam/AT 0-4MB Board	149
Boca MultiEGA	189
DCA	
Irma 2 3278 Board	729



INTEL Inboard
386/PC w/1MB RAM
\$579

Emerald

3XTwin 5251 Local Emulat.	669
Everex	
Magic I/O AT Par/Ser	59
Ram 3000 Deluxe 0-3MB Bd.	89
Micro Enhancer EGA	169
5th Generation	
Logical Connection 256K	449
Hercules	
Graphics Card Plus	179
Intel	
AboveBoard 2 Plus w/OK	319
AboveBoard PS/286 w/512K	419
AboveBoard Plus w/512K	429
AboveBoard Plus I/O 512K	579
8087 IBM PC/XT CoP.	95
80287-8 IBM XT 8MHz CoP.	219
80387-16 16MHz 80386	399
Orchid Technology	
ProDesigner VGA	329
TinyTurbo 286	279

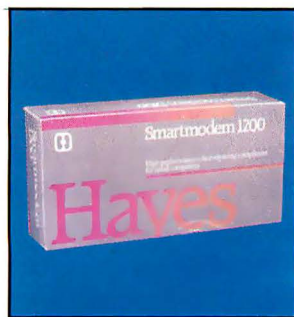

HAYES
SmartModem 1200
\$269

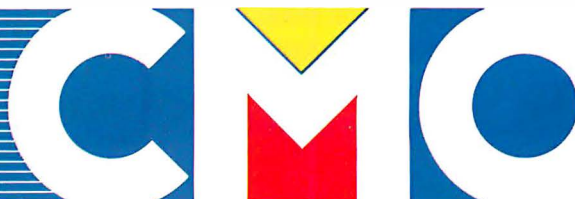

Your Source for Hardware, Software & Peripherals

For Quality Computer Products.

Paradise
AutoSwitch EGA 480 Adpt. Call
Video 7
Vega VGA Adapter \$285
FastWrite Video Adapter 349

STORAGE DEVICES

American Power
450AT + UPS Backup 439
ATD-ZuckerBoard
Tandy 30MB HardCard 479
Everex
Floppy Stream 40 40MB Int. 359
Excel Stream 40T 40MB Int. 529
Miniscribe
8425 20MB 3½" 40Msec 259
3650 40MB 5¼" 61Msec 349
6085 70MB 5¼" 28Msec 599
Mountain Computer
TD-4340 40MB Int. Tape 319
TD-8000 80MB Ext. Tape 445
Plus Development
20MB HardCard 549
Seagate
ST-225 20MB w/cont 249
ST-238 30MB w/cont 279
Sysgen
Bridge-File 5½" External 249
SmartImage 60MB Internal 479
QIC-File 60MB External 599
Omni Board Controller 79

COMPUTERS

Amstrad
PPC-640 Portable 849
AST
Premium 286 Model 80 1459
Compaq
Deskpro & Portable 286/386 Call
NEC
Multimate Laptops Call
PC-TOO
640K 10MHz 8088 Desktop 699
512K 12MHz 80286 Desktop 999
Sysgen
ProSystem 12MHz w/40MB 1999
Toshiba
T1000 8088 Laptop 789
T1200 Floppy/HrdD Lptp Call
Zenith
80286/386 Desktops Call
SuperSport 20MB w/Modem 1999

COMMUNICATIONS

Anchor
6480 C64/128 1200 Baud 99
520 ST520/1040 1200 Baud 129
1200 Baud External 109
Atari
XMM301 XL/XE 300 Baud 44
SX-212 ST Modem 89
Avatex
1200 HC External 99
2400 Baud External 179
ATD-ZuckerBoard
2400 Baud External 129
Everex
Evercom 12 1200 Baud Int. 79
Evercom 24 2400 Internal 149
Evercom 24E+ 2400 Bd. Ext. 199
Hayes
SmartModem 2400 Baud 429
Intel
2400B Classic Internal 249

This Month's Featured Product:

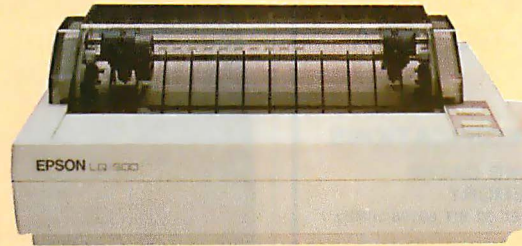

EPSON LQ-500
180 CPS, 80 Column 24-Wire Printer **\$275**

Murata
M1200 Facsimile \$779
Practical Peripherals
1200 Baud Internal 69
1200 Baud Stand Alone 109
2400 Baud Stand Alone 189
Sharp
FO-220 Facsimile Machine 999
Supra
2400AT 2400 Baud Atari 169
U.S. Robotics
1200 Baud Direct Ext. 109
2400 Baud Direct Ext. 199

PRINTERS

Alps
ASP-1000 9-Pin Flatbed 189
Allegro 24 24-Pin Flatbed 349
Brother
M-1709 240cps, 132 Col. 389
M1724L 24-Wire, 132 Col. 569
HR-20 20cps Daisywheel 359
HR-40 40cps Daisywheel 599



HEWLETT PACKARD
ThinkJet 2225
\$329

Epson
LX-800 180cps, 132 Col. 169
FX-850 264cps, 80 Col. Call
FX-1050 264cps, 132 Col. Call
Call For LQ Rebates
LQ-850 330cps, 24-Wire Call
LQ-950 264cps, 24-Wire Call
LQ-1050 330cps, 132 Col. Call
NEC
P2200 Pinwriter 24-Wire 349
P5200 Pinwriter 265cps 579
Okidata
ML-182+ 180cps, 80 Col. 249
ML-320 300cps, 80 Col. 359
ML-390 270cps, 24-Wire 499
Panasonic
KX-P1180 192cps, 80 Col. 189
KX-P1191 280cps, 80 Col. 259
KX-P1124 192cps, 24-Wire 349

KX-P1524 24-Wire, 132 Col. \$579
Star Micronics
NX-1000 144cps, 80 Col. 169
NX-1000 RainBow Color 239
NX-2400 24-Wire, 80 Col. 369

Toshiba
ExpressWriter 311 New

MS-DOS SOFTWARE

Ashton-Tate
dBase IV 479
MultiMate Advantage II 289
Borland
Paradox R-Database 439
Quattro 149
Central Point
PC Tools Deluxe 49
DAC Software
DAC-EASY Accounting 59
5th Generation
FastBack Plus 99
Fox Software
Fox Base + Development 199
IMSI
OptiMouse w/Dr. Halo III 79
Logitech
C7 Mouse w/Software 79
ScanMan Scanner 199

Lotus Development
Lotus 1-2-3 \$299
MECA
Managing Your Money 119
Meridian Technology
CarbonCopy Plus 5.0 119
Microsoft
Serial or Buss Mouse 109
MSC
OmniMouse 49
Peter Norton
Advanced Utilities 79
Peachtree
Complete Accounting 169
Quarterdeck
DESQView 2.02 79
Server Technology
EasyLan Starter Kit 179
Software Publishing
1st Choice 3.0 89
1st Publisher 2.0 79
Professional Write 2.0 179
The Complete PC
HandScan For PC 179
Complete Answer Machine 269
Traveling Software
Lap-Link Plus 84
Xerox
Ventura Publishing 2.0 445

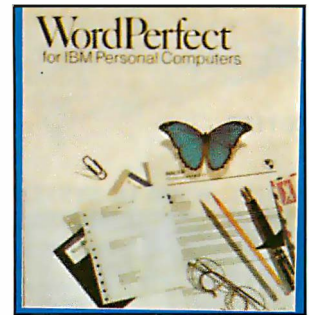

WORDPERFECT CORP.
WordPerfect
\$199



Your Source for Hardware, Software & Peripherals

In U.S.A.

800-233-8950

In Canada call: 800-233-8949

All Other Areas call: 717-327-9575 Fax call: 717-327-1217

Educational, Governmental and Corporate Organizations

Call toll-free: 1-800-221-4283

CMO, 101 Reighard Ave., Dept. A1, Williamsport, PA 17701

Over 400,000 SATISFIED CUSTOMERS • MAJOR CREDIT CARDS ACCEPTED

POLICY: Add 3% (minimum \$7.00) shipping and handling. Larger shipments may require additional charges. Personal and company checks require 3 weeks to clear. For faster delivery, use your credit card or send cashier's check or bank money order. Credit cards are not charged until we ship. Pennsylvania and Maryland residents add appropriate sales tax. All prices are U.S.A. prices and are subject to change. All items are subject to availability. Defective software will be replaced with the same item only. Hardware will be replaced or repaired at our discretion within the terms and limits of the manufacturer's warranty. We cannot guarantee compatibility. All sales are final and returned shipments are subject to a restocking fee. We are not responsible for typographic or photographic errors.

MEMBER
MMC
MICROCOMPUTER
MARKETING COUNCIL
OFFICE: 101 REIGHARD AVE., DEPT. A1, WILLIAMSPORT, PA 17701

A104

THE HIGHEST PERFORMANCE BOARD IN THE 386 WORLD

A STATE-OF-THE ART DESIGN FROM AMERICAN MEGATRENDS INC. U.S.A.

KAOTEC 80386-20 SYSTEM



TR-8000 386-20 MINITOWER CASE
TR-8001 DESKTOP

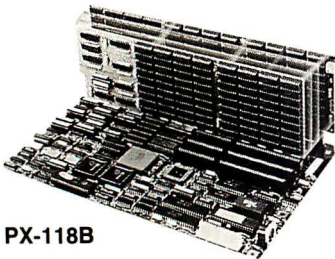

PX-118B

KAOTEC 80286-16 SYSTEM



TR-6001 DESKTOP
TR-6002 SLIMCASE

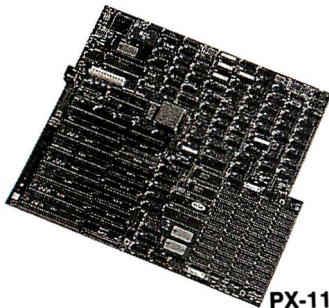

PX-116C

SPECIFICATIONS

- 64KB CACHE MEMORY
- INTEL 32 BIT 80386-20MHz CPU
- 128K ROM(AMI BIOS + EGA BIOS)
- SOCKET FOR 80387 CO-PROCESSOR
- 20MHz SYSTEM CLOCK
- SYSTEM CLOCK SWITCH BY KEYBOARD (AMICLK FOR EUROPEAN KEYBOARD PROGRAM)
- 8 LAYERS P.C.B.
- 6 EXPANSION SLOTS: 1 x 32, 4 x 16, 1 x 8
- OPTION 2MB/8MB RAM BOARD CAN BE EXPANDED TO 10MB/16MB BY INSTALLING 8MB PIGGY BACK
- AMI BIOS-386 BUILT-IN-SETUP & DIAGNOSTICS
- PERFORMANCE NORTON SI23.0 LAMARK TEST 30MHz
- 32 BIT ROM BIOS FASTER THAN SHADOW RAM
- DALLAS SEMICONDUCTOR REAL TIME CLOCK DS-1287A; WITH AN INTERNAL ENERGY SOURCE POWER DURABLE OVER 10 YEARS (MAINTAINS AN ACCURACY OF 1 MINUTE PER MONTH AT 25°C)
- EMS DRIVER AVAILABLE BY SOFTWARE OF AMI SEEMS
- AMD 80286-10/80286-12 MICRO-PROCESSOR
- 6MHZ, 8MHZ, 10MHZ or 12MHZ SYSTEM CLOCK WITH LED INDICATOR
- SOFTKEY SELECTABLE SYSTEM CLOCK
- HARDWARE RESET JUMPER
- 512K/640K/1024K/2048K/4096K BYTES RANDOM-ACCESS MEMORY (RAM)
- DALLAS SEMICONDUCTOR REALTIME CLOCK DS-1287A WITH AN INTERNAL ENERGY SOURCE POWER DURABLE OVER 10 YEARS (MAINTAINS AN ACCURACY OF ± 1 MINUTE PER MONTH AT 25°C)

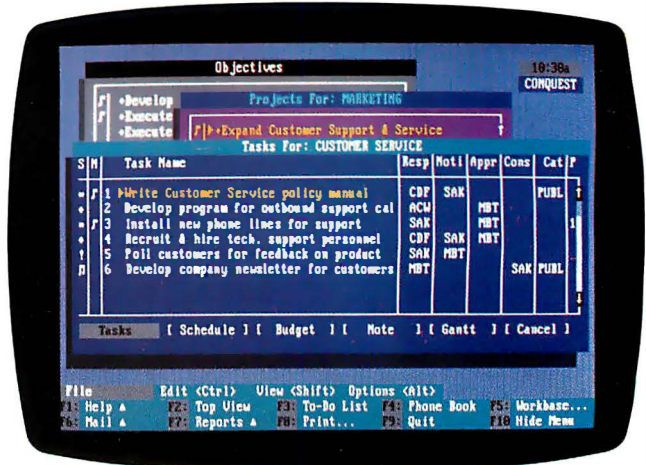

SYZGY lets you manage multiple projects in real time.

Processing Words the Mac Way

Paragon has gone one step further with its text editor QUED/M and created Nisus, a word processing program for the Macintosh.

The company says that the word processor stores text and formatting separately, so you can open and edit Nisus documents in any program or desk accessory.

In addition, the program offers a feature called Zap Gremlins, which deletes any surplus characters that might result from importing text from another operating system.

The program's search and replace makes use of GREP, and its find and replace facility lets you search by style and fonts. An Easy-GREP facility features a pull-down menu.

Ten clipboards are included in the program, each of which you can edit, append to, save, or print. An undo facility is included, as is a page-preview feature.

Paragon claims you can have any number of files open at once, and you can tile or stack windows. The program's graphics capabilities let you draw graphics directly into text, place a picture over text, or have text wrap around it.

You can use the Clipboard or other applications to draw or paste graphics.

Nisus runs on the Macintosh with 1 megabyte of RAM (2 megabytes under Multi-Finder). It supports the LaserWriter and the Imagewriter printers.

Price: \$395.

Contact: Paragon Concepts, Inc., 4954 Sun Valley Rd., Del Mar, CA 92014, (619) 481-1477.

Inquiry 1130.

Tools for the Legal Trade

CompareRite, CiteRite II, and FullAuthority, three of Jurisoft's productivity programs, are now grouped together in one package called The Legal Toolbox.

CompareRite is a redlining program that lets you compare two versions of a document; it creates a redlined draft for you, showing the differences between the two.

CiteRite II is a citation program that checks Bluebook and California-style citations without requiring text markers to indicate where the citations

continued



HWA Hsin Electronic Co., Ltd.

5F., NO. 12, LANE 538, CHUNG-CHENG RD., HSINTIEN, TAIWAN, R.O.C.
TEL: 886-2-9153375 FAX: 886-2-9186892 TELEX: 35210 TRONIX

ATTENTION ROM DEVELOPERS!

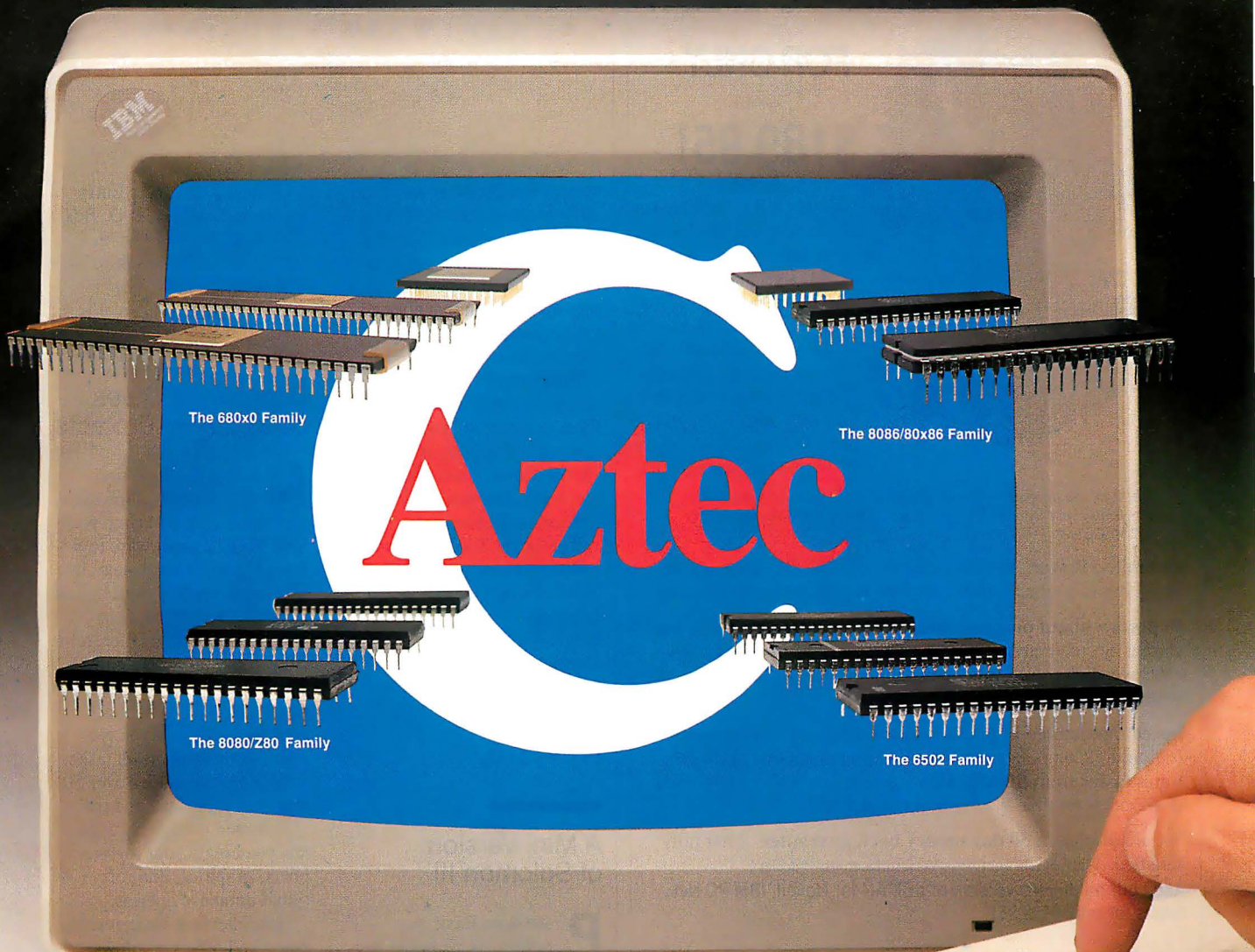

Aztec C ROM Cross Development Systems Produce Fast, Tight C Code with Less Effort

Aztec C ROM Cross Development Systems give you the best results — clean, tight and fast running code. Aztec C systems are available for a variety of targets and for both MS-DOS or Apple Macintosh hosts! And, Aztec C systems come complete with all the tools to edit, compile, assemble, optimize and, now, *source debug* your C code in less time and with less effort.

Quality, tight code that's fast and efficient. An abundance of tools to produce better results in less time. That's why Aztec C

systems are the choice of more professional ROM developers.

So when you're looking for the best results, insist on Aztec C ROM Cross Development Systems. Call today and find out more about our complete line of Cross Development Systems.

Supported targets include: the 68xxx family, the full 8086 family, the 8080/Z80 family and the 6502 family of microprocessors.

1-800-221-0440 (outside NJ)

(NJ and Outside U.S.) **1-201-542-2121** Telex: 4995812MANX Fax: 201/542-8386

Aztec by MANX
SOFTWARE SYSTEMS

P.O. Box 55, Shrewsbury, New Jersey 07702

MS-DOS is a registered trademark of Microsoft Corporation
Apple and Macintosh are registered trademarks of Apple Computer Corporation.

Circle 162 on Reader Service Card

APRIL 1989 • BYTE 85

MORE dBASE POWER!

FOR ONLY

\$189.95!



dB MAN V: A database manager for your PC that has dBASE III+ power, Report Writer, and Compiler all in one package! Now you can buy a powerful dBASE III+ work-alike that includes more features and power than any other competitive product on the market, at a fraction of the cost!

"dBMAN competes directly with dBASE III+, it runs many operations much more quickly and costs less than half the price." Bruce Brown, PC Magazine.

Unlimited Power. We extended the dBASE III+ language to bring you to a new level of programming power and versatility.

Reports without programming! With our Report Writer you can easily create invoices, sales statements, form letters, employee lists, multi-lined and columnar reports, and more. All without programming!

Speed unequalled in performance. dBMAN V's Greased Lightning! Compiler executes dBASE applications up to 16 times faster than dBASE III+, and comes with an unlimited distribution runtime license at no extra cost!

We are offering a **30 day money back guarantee** if not fully satisfied. (When purchased from a Versasoft authorized dealer.)

And, our multi-user version of dBMAN for Novell, IBM PC Net retails for only **\$499.95!**

Just compare our price with the competition:

Program	Interpreter	Compiler	Report Writer	TOTAL
dBMAN V	\$189.95	included	included	\$189.95
FoxBASE	\$395.00	\$495.00	\$149.95*	\$1039.95
Clipper	N/A	\$695.00	\$149.95*	\$844.95
QuickSilver	\$199.00	\$599.00	\$149.95*	\$947.95
dBASE III+	\$795.00	N/A	\$149.95*	\$944.75
dBASE IV	\$1295.00	included	included	\$1295.00

* Suggested retail price for comparable relational full-screen report writer.

dBMAN Highlights:

- dBASE II and dBASE III+ compatibility
- 320 extended commands and functions
- Password protection and data security at field level
- BCD numbers
- Single command menus: vertical, horizontal, scrollable and pull down menu
- Program debugger/editor

Report Writer Highlights:

- User defined pop-up windows and more...
- 9 group levels
- Conditional printing of any items
- Compute running sums, counts, averages, minimums and maximums
- Relate and report from up to 9 database files with lookup (one to one) and scan (one to many) relations and more...

Multi-User Version:

- Locks records and files as a set to prevent deadlock
- Supports transaction update and roll back (Novell TTS system) and more.
- Available for Novell Network, IBM PCNet, Xenix, UNIX and other major operating systems.

Call today to order your copy of dBMAN V !

Versasoft Corporation

4340 Almaden Expwy, Suite 250
San Jose, CA 95118
Phone: 408-723-9044
Telex: 650-263-5806
Fax: 408-723-9046

WHAT'S NEW

SOFTWARE • BUSINESS

occur. The program automatically locates citations in legal documents, checks them for proper form, and reports any errors. You can operate it as a pop-up program that checks citations from within your word processor.

FullAuthority looks for citations in briefs and arranges them to create a formatted table of authorities. It lets you choose to sort them into statute, book, law review, or other citation categories.

The Legal Toolbox runs on the IBM PC with 210K bytes of RAM and DOS 2.0 or higher.

Price: \$365.

Contact: Jurisoft, Inc., 763 Massachusetts Ave., Cambridge, MA 02139, (617) 864-6151.

Inquiry 1133.

Contact: TLB, Inc., Entry Products Division, P.O. Box 414, Findlay, OH 45839, (800) 777-0521; in Ohio, (419) 424-0422.

Inquiry 1131.

Groupware Gives Structure to Projects

Manage multiple projects, people, schedules, and budgets in real time with SYZGY, a groupware tool from Information Research. The program lets you delegate assignments and monitor workgroups with its hierarchical activity tool. Using the Gantt chart tool, you can show due dates and status of all your projects, and you can zoom in on lower-level tasks.

SYZGY includes over 50 report capabilities, and the SQL-based query language lets you create your own reports, graphics, and relational database queries.

The interface is object-oriented and offers windows, scroll bars, and cut, paste, and copy tools. SYZGY files are compatible with DIR, SYLK, XLS, WKS, and WK1 files.

The program runs on the IBM PC with 512K bytes of RAM. It supports monochrome, Hercules, CGA, EGA, and VGA monitors. A NetBIOS-compatible network version is available.

Price: \$395; network version for two users, \$595; three to 10 users, \$995; 11 to 25 users, \$1495; unlimited users, \$1995.

Contact: Information Research Corp., 2421 Ivy Rd., Charlottesville, VA 22901, (800) 368-3542; in Virginia, (804) 979-8191.

Inquiry 1132.

A Mini Version of Solomon III

ProfitWise Basic Accounting is a smaller version of Solomon III Accounting Software for businesses with annual revenues of less than \$500,000. The major difference between the two programs is the limitation placed on the number of transactions that ProfitWise will handle. The databases of both systems are compatible, so you can upgrade to Solomon III, the company reports.

ProfitWise includes general ledger, accounts payable and receivable, payroll, invoicing, fixed assets, and address modules. Add-on modules include inventory and job costing, and report and graph designer.

The program runs on the IBM PC with 512K bytes of RAM, 10 megabytes of hard disk storage, and DOS 3.1 or higher. You'll need 576K bytes for the report designer.

Price: \$229; add-on modules, \$229 each.

continued



dBASE III+ and IV are trademarks of Ashton-Tate. FoxBASE is a trademark of Fox Software. Clipper is a trademark of Borland. QuickSilver is a trademark of WordTech Systems. Novell Network, IBM PCNet, Xenix, UNIX are trademarks of Novell, IBM, Microsoft, AT&T Bell Laboratories respectively.

Turn a task into child's play.

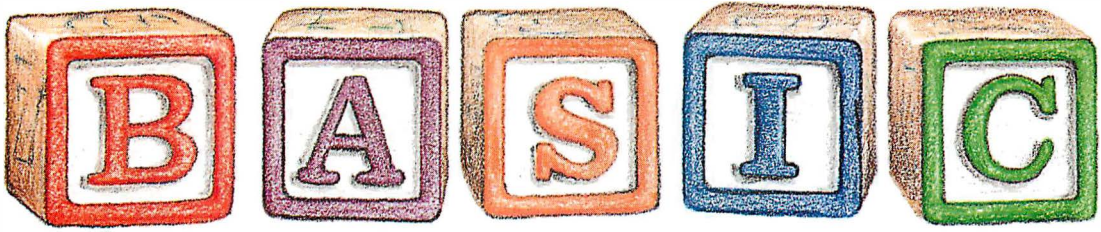

PROBAS™ Basic Programming Library

Announcing **PROBAS** Version 3.0, now with over 365 assembly routines to really kick QuickBASIC and BASCOM into high gear. *BYTE* magazine calls **PROBAS** a "Super-charger for QuickBASIC". Thousands of programmers rely on **PROBAS** to make their life easier and to enhance their programs with features like:

- A 1,000 page 2 volume manual
- Full-featured windowing
- Screen snapshots (Text & Graphics)
- String, array, and pointer sorts
- Lightning-fast file I/O
- Full mouse support

Create dazzling screens in text mode, CGA, EGA, VGA or Hercules graphic modes. Save and restore screen snapshots to arrays, EMS memory or files. Full featured windowing to meet the most demanding jobs. The **PROBAS** system of virtual screens allows you to draw full or partial screens to memory, and then snap them on in an eyeblink. You can even create virtual screens far larger than the display screen.

Sick of running out of string space? Store hundreds of K in numeric arrays or megabytes in extended or expanded memory. Tired of using a kludgy SHELL to DIR to read a directory or archive files? Scan sub-directories or .ARC files using wild-cards and store thousands of file names, dates, and times. Wish you could drag a window containing text or a menu around the screen with a mouse? It's easy!

PROBAS gives you a complete set of blazingly-fast file routines. Read or write huge chunks of data at a clip, with file locking and error handling so that you can even use them in subprograms. You'll never want to use BASIC's file I/O again! Sort data with lightning fast array and pointer sorts. Search files or arrays at assembly speeds. **PROBAS** also has over 200 other essential services including handy string, date, time, directory and array manipulation, string, screen and data compression, full mouse support, valuable equipment and input routines and faster replacements for most BASIC commands.

Whether you are a professional or a novice, **PROBAS** will boost your BASIC in ways you never dreamt possible. **PROBAS** allows professionals to save time and work and lets novices write professional-quality programs quickly and easily. After all, how much is a few hundred hours of your time really worth?

For all versions of QuickBASIC and BASCOM including BASCOM 6.0 for OS/2. **Just \$135.00!**

PROREF™ On-Line Help For PROBAS

PROREF provides pop-up help for the routines in **PROBAS** and is an extension of the QuickBASIC programming environment. Find help on any routine with a few keystrokes or mouse clicks. Pop-up an ASCII chart, calculator, scan code module, box diagram, your own help information or almost any DOS program via a hot-key. **Just \$50.00!**

PROSCREEN™ Screen Management

PROSCREEN is a full-featured screen generator/editor that will save you more design and coding time than you ever thought possible. **PROSCREEN** treats screens like a word processor treats text to provide complete control over characters, colors, and placement. Design input screens with up to 130 fields and 19 pre-defined and 2 user-defined masks. Use **PROBAS** or the included BASIC/Assembler subroutines to access the screens. No kludgy code generators here! Comes with subroutine source, extensive on-line help, and a 285 page manual. **Just \$99.00!**

PROMATH™ Mathematics Library

PROMATH is a collection of over 150 high-level routines that provide mathematical functions and operations for programmers who often work in mathematics, science, or engineering. Complex variables, real and complex matrices, real and complex trigonometric and hyperbolic functions and their inverses, solution of linear equations, integration, differential equations, Fast Fourier transforms, graphics support, and many other useful routines are provided.

For years Fortran has been the language of choice for scientific and engineering applications, but it lacks many of the useful features of QuickBASIC. **PROMATH** contains most of the Fortran mathematical and numeric functions and allows you to easily translate Fortran code to BASIC or write new programs in BASIC while retaining Fortran's numerical prowess.

The **PROMATH** manual is over 200 pages and provides a complete description of each routine, including any algorithm and the mathematical formula the routine uses, shown in standard notation. For QuickBASIC 4 and BASCOM 6 only. **Just \$99.00!**

PROBAS™ TOOLKIT

The **TOOLKIT** is a collection of assembly and BASIC modules that use the **PROBAS** library to save you even more hours of grunt work. Why spend hundreds of hours re-inventing the wheel when you can just plug in **TOOLKIT** modules like:

- Menu Generators
- Fast B-tree indexing
- Mini-editor with word-wrap
- Patch .EXE files
- Protected storage areas
- Julian date routines

The **TOOLKIT** also includes clock, calendar, windowing, BCD math routines and much more, complete with BASIC source code and a comprehensive manual. The **PROBAS TOOLKIT** adds capabilities and helps conserve your most valuable asset of all—time! Requires **PROBAS**. **Just \$99.00!**

PROBAS™ TELECOMM TOOLKIT

The **PROBAS TELECOMM TOOLKIT** is a collection of high-level communications modules that you plug into your code to provide popular file transfer protocols, terminal emulations, login scripts and baud rates up to 115,200 baud. You get:

- Xmodem/Modem7/Xmodem-1 k
- Ymodem (single and batch)
- CRC-16 and Checksum
- VT52, VT100, ANSI BBS etc.
- Auto Dialer & data base
- Documented BASIC source

Why use clumsy SHELLs to complex terminal programs when you can plug just the communications routines you need into your code? Implement just the features and commands you want. Requires **PROBAS**. **Just \$75.00!**

Our thirty day, money-back guarantee assures you the highest quality and our technical support staff is always ready to help.

HAMMERLY
COMPUTER SERVICES, INC.

9309 JASMINE COURT • LAUREL, MD 20707

(800) 343-7484

INT'L. ORDERS: (301) 953-2191 FAX: (301) 725-8147
BBS: (301) 953-7738

Add \$5.00 per item (\$8.00 Canada) for shipping per order. Europe: \$39.00 for 1st item plus \$5.00 for each additional item. Visa, M/C, C.O.D. (US Only) checks and approved POs accepted. Trademarks **PROBAS**, **PROREF**, **PROSCREEN**, **PROMATH**: Hammerly Computer Services, Inc. QuickBASIC, BASCOM: Microsoft Corp.

Power



T5200: 20MHz 386 processor, 2 internal IBM®-compatible expansion slots, VGA gas plasma display with VGA monitor port, 40MB or 100MB hard disk, 2MB RAM standard expandable to 8MB, 1.44MB 3½" diskette drive.

At Toshiba, we're not only committed to making computers more portable, but also to making portables more powerful.

Which is why, in our effort to constantly improve and refine our machines, we've added three new computers to what is already the most complete family of truly portables available.

Each designed to be powerful enough to take on the increasingly complex tasks that face today's sophisticated PC users.

First, the T1600 which weighs under 12 pounds and which is the fastest battery-

powered computer we've ever made.

Second, the T3100e, the successor to our most popular machine—the T3100/20. We've made it nearly two pounds lighter and a lot faster—we've even added expansion capabilities. About the only thing we didn't add was more size.

T1600: Battery-powered 286/12MHz, coprocessor socket, 20MB hard disk at 27msec, 1.44MB 3½" diskette drive, 1MB RAM expandable to 5MB, detachable backlit EGA compatible LCD, removable rechargeable battery pack.

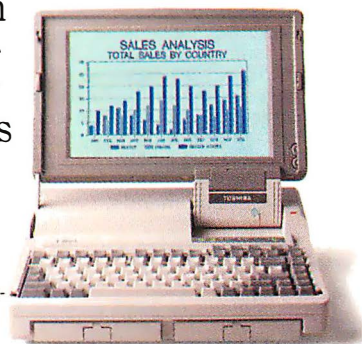

Toshiba is the world leader in truly portable PCs and manufactures a complete line of high quality dot-matrix and laser printers. For more information call 1-800-457-7777. All Toshiba PCs are backed by the Exceptional Care program (no-cost enrollment required). IBM is a registered trademark of International Business Machines Corporation. Model T5200 has not been approved by the Federal Communications Commission. This device is not, and may not be, offered for sale or lease, or sold or leased until the approval of FCC has been obtained.

Surge.



And finally, the T5200, which has enough power to replace virtually any desktop PC.

But we haven't just concentrated on power and portability. We've also constantly looked for ways to make our machines more durable, more reliable, and easier to use—down to the 800 number our customers can call for help with any technical question that might come up.

We figure that's what our users demand.

And it's by anticipating the growing needs of our users that we have continually found ways to make our machines weigh

less and do more. So you can work wherever you want and however you want.

All of which might make it tempting for some people to abandon their desktop for the convenience of portability. Go ahead.

We've given you the power to do it.

T3100e: 12MHz 286 with 80287 coprocessor socket, internal half-length IBM slot, 20MB hard disk with 27 msec access, 1MB RAM expandable to 5MB, gas plasma display, 1.44MB 3½" diskette drive.

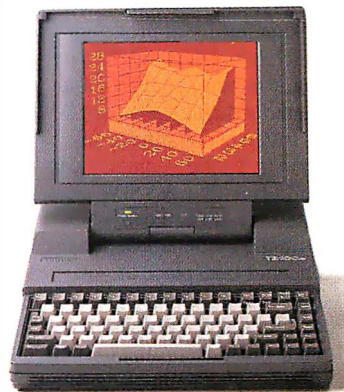

In Touch with Tomorrow
TOSHIBA

Toshiba America Inc., Information Systems Division

Circle 282 on Reader Service Card
(DEALERS: 283)

APRIL 1989 • B Y T E 89

Networked Decisions

Ashton-Tate's integrated software program, Framework, is now available in a network version. Framework III LAN supports five users and includes built-in E-mail, file locking with three file-sharing modes, and peripheral sharing.

Framework includes word processing, database, spreadsheet, business graphics, outlining, and E-mail facilities. The program uses the standard message format, Message Handling Service, developed by Action Technologies and Novell. This lets you communicate with other Framework III users as well as users of other software packages imple-



With Framework III LAN's E-mail, you can communicate with users of Framework III and other mail systems.

menting the MHS message format. You can also send mail over phone lines from one LAN to another and from LANs to remote PCs, according to Ashton-Tate.

Framework III is available

in a variety of international languages, and Ashton-Tate reports that the LAN version will be available in translated editions in the spring of 1989. All screens, menus, messages, spelling dictionaries,

and documentation will appear in the local language. Optional disks with spelling checkers, hyphenation programs, and thesauri are available in German, French, British English, Italian, Dutch, Swedish, Spanish, Danish, Norwegian, and Portuguese.

Framework III LAN runs on the IBM PC with 640K bytes of RAM. It supports the following networks: Novell Advanced and SFT NetWare/286; IBM PC and Token Ring networks running IBM PC LAN; the 3Com 3+ Network; and the AT&T StarLAN.

Price: \$995 for five users.
Contact: Ashton-Tate Corp., 20101 Hamilton Ave., Torrance, CA 90502, (213) 329-8000.

Inquiry 1136.

First Solids Modeler for the Mac

With three-dimensional design and two-dimensional drafting capabilities, Infinite Graphics calls In-CAD the first true solids modeler for the Macintosh II. In-CAD is the first in the In-Vision family of programs for mechanical design, engineering, drafting, analysis, and manufacturing.

In-CAD combines constructive solid geometry capabilities with a WYSIWYG interface, so you can work with the modeler and see the changes take place as you make them. The program differentiates between material and voids, according to Infinite Graphics. Building-block primitives and Boolean operations are used to add and subtract material, and you can view models from any direction with hidden lines re-

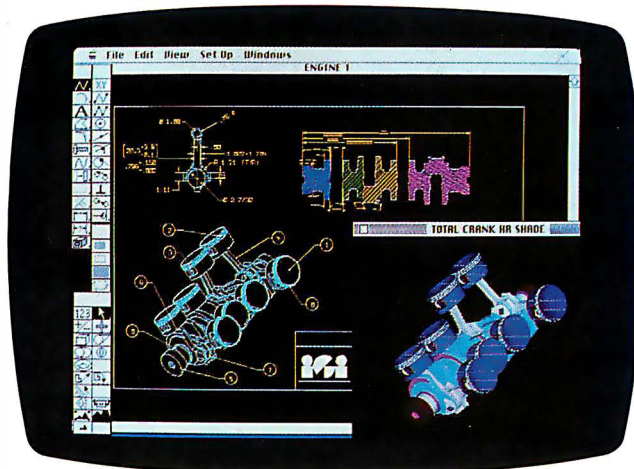

In-CAD gives the Mac three-dimensional design, two-dimensional drafting, and solids modeling capabilities.

moved, shaded, or sectioned. The program also calculates area and mass/volume properties. In addition, you can modify any portion of the model, and the changes will

be made automatically throughout the model.

Other capabilities include dimensioning, splines, user-definable text fonts and cross-hatch patterns, full geometry creation and editing, subfigures for library parts and components, user-

definable attributes and grouping, labeling with balloons and automatic incrementing, variable-width lines, and a programming language. The program also offers associative dimensioning with the ability to update dimensions that are related to a dimension that you've changed.

In-CAD runs on the Mac II. It features an Initial Graphics Exchange Specification translator for importing and exporting files between other CAD systems. A translator is also included for AutoCAD DXF files. The program supports Mac menus, desk accessories, and a windowing environment. You can also use a tablet or text commands.

Price: \$1945.

Contact: Infinite Graphics, Inc., 4611 East Lake St., Minneapolis, MN 55406, (612) 721-6283.

Inquiry 1137.

continued

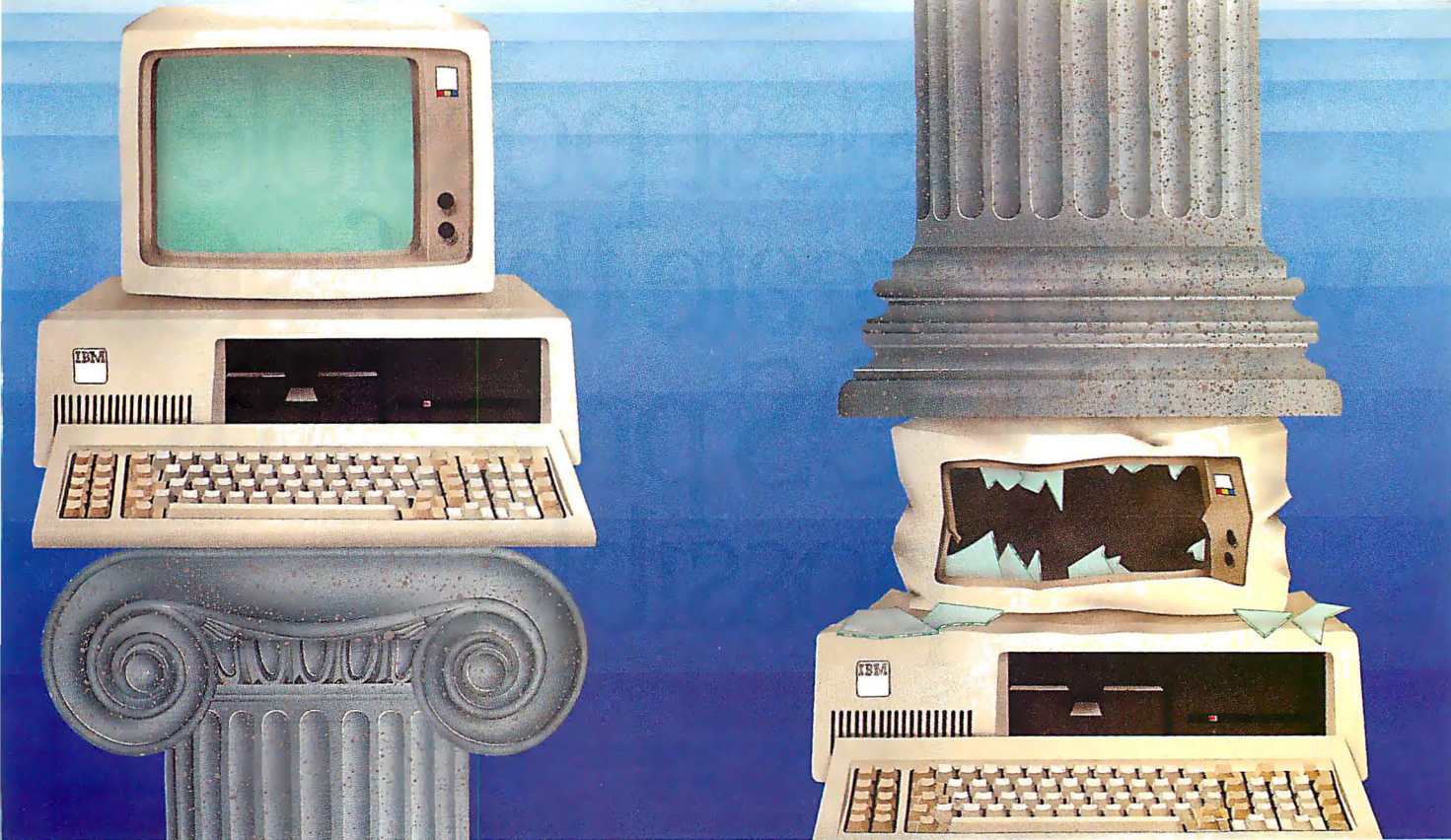

QNX[®] vs. UNIX OS/2

Architecture can make or break a computer system.

Don't make your systems bear the brunt of massive, monolithic monsters like Unix or OS/2. Instead, build your systems with QNX. The lean, efficient OS that's flexible enough to support any application.

MULTIUSER, MULTITASKING, NETWORKING, AND MORE... QNX is both multiuser *and* multitasking. OS/2 isn't multiuser. Unix may be multiuser and multitasking, but it will hog a huge chunk of your hard disk and system memory. And neither Unix nor OS/2 can do integrated networking.

QNX, on the other hand, hums along using an efficient 150K of RAM, yet provides a powerful multiuser, multitasking, and integrated networking environment.

TRUE DISTRIBUTED PROCESSING. A QNX-based PC LAN lets any user share *any* resource on the network—programs, data, devices, even CPUs—without going through the bottleneck of a central file server. With QNX you get mainframe power at micro prices.

ADDED VALUE FOR VARS. QNX is flexible enough to run on *any mix of*

PCs, ATs, PS/2s, with or without dumb terminals. Even diskless workstations are supported. So whether you start small or grow to mainframe proportions, you can easily build and maintain powerful, fault-tolerant systems without spending a fortune on hardware.

REALTIME PERFORMANCE. Only QNX combines the performance of a dedicated realtime executive with the convenience of a rich development environment that includes a host of utilities, C compiler, full-screen editor, symbolic debugger, and multiple full-screen windows.

DOS SUPPORT. For those who need their daily dose of DOS, QNX allows a DOS application to run as a single task on each PC on the network.

FREE TECHNICAL SUPPORT. While users of other operating systems have to cough up hefty fees for support, QNX developers enjoy *free* hotline support and *free* BBS access. You'll get prompt answers to your questions and you'll share ideas and insights with fellow developers in the QNX community.

It's time to make the move to QNX.
Circle 233 on Reader Service Card

THE ONLY MULTIUSER, MULTITASKING, NETWORKING, REALTIME OPERATING SYSTEM FOR THE IBM PC, AT, PS/2, AND COMPATIBLES

Multiuser	10 (32) serial terminals per PC (AT)
Multitasking	64 (150) tasks per PC (AT)
Networking	2.5 Megabit token passing. 255 PC's and/or AT's per network. Thousands of users per network.
Realtime	4,250 task switches/sec (AT).
Message Passing	Fast intertask communication across the network.
C Compiler	Standard Kernighan and Ritchie.
Flexibility	Single PC, networked PC's, single PC with terminals, networked PC's with terminals. No central servers. Full sharing of disks, devices and CPU's.
PC-DOS	PC-DOS runs as a QNX task.
Cost	From US \$450. Runtime pricing available.



For further information or a free demonstration diskette, please telephone (613) 591-0931.

Quantum Software Systems Ltd. • Kanata South Business Park • 175 Terrence Matthews Crescent • Kanata, Ontario, Canada • K2M 1W8
Come meet with us! COMDEX/Spring '89 April 10-13, McCormick Place. Chicago, IL. Booth #2843

QNX is a registered trademark of Quantum Software Systems Ltd. The UNIX Operating System is a registered trademark of AT & T. IBM, PC, AT, XT and PS/2, PC-DOS and OS/2 are trademarks of International Business Machines.

The fastest possible way to create the fastest MS-DOS programs possible.

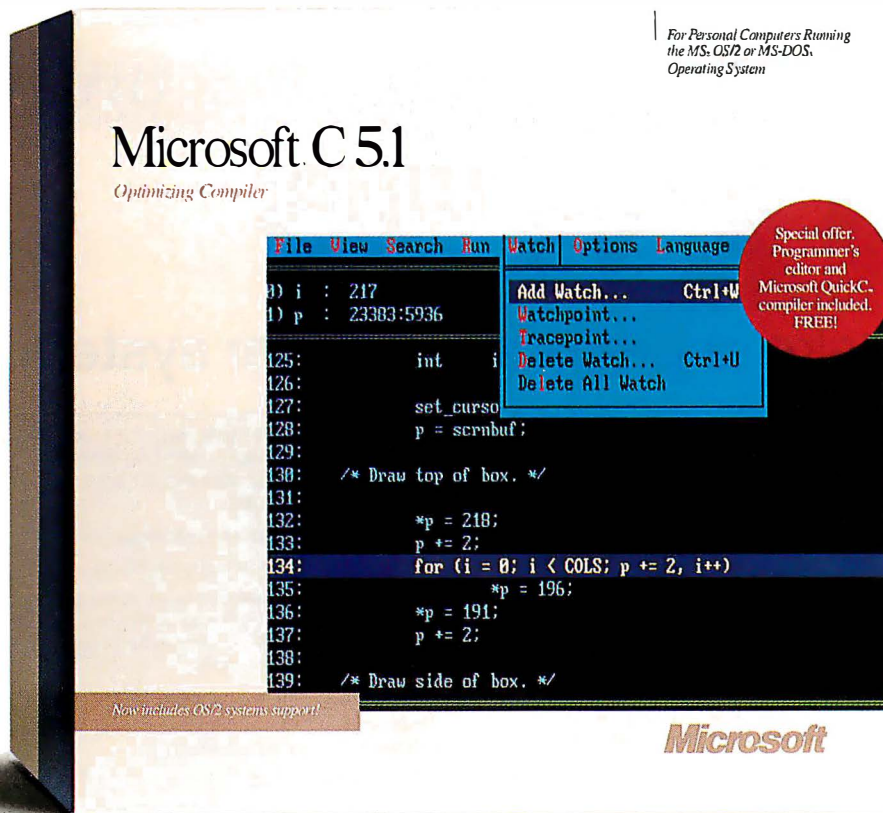

For Personal Computers Running the MS-DOS or MS-DOS Operating System

Microsoft C Optimizing Compiler 5.1 Techbox

Compiler

- Optimizations that generate the fastest code for DOS and OS/2 systems.
 - In-line code generation.
 - Loop optimizations.
 - Elimination of common subexpressions.
- Full OS/2-system support to break the 640K barrier.
 - Family API programs that run under DOS and the OS/2 systems.
 - Write multithreaded programs and Dynamic Link Libraries.
- Small, medium, compact, large, and huge memory models.
- Mix models with NEAR, FAR, and HUGE keywords.
- Fast compilation (10,000 lines/minute) with Microsoft QuickC™
- Fastest math, in-line 8087/80287 instructions, and floating-point calls.
- More complete support of proposed ANSI standard.
- Over 350 library functions, including a graphics library.

Microsoft CodeView

- Full OS/2 systems support.
 - Debug applications of up to 128 MB under the OS/2 systems.
 - Debug multithreaded programs and Dynamic Link Libraries.
- Source-level debugging for precise control over programs.
 - Dynamic breakpoints in the source.
 - Debug programs written in a variety of Microsoft languages.
 - Full symbolic display of C structures.
 - Interactively follow linked lists and nested structures.
 - Watch variables, memory, registers, and flags.

Other Utilities

- Fast linking (twice as fast as the C 4.0 version linker).
- OS/2 incremental linker - up to 20 times faster than a full link.
- OS/2- and MS-DOS reconfigurable programmer's editor

Everything about Microsoft® C Optimizing Compiler version 5.1 is dedicated to the professional programmer.

Fast code. Fast development. Fast debugging. And full support for both MS-DOS® and the OS/2 systems in a single package.

There's no faster C code on a PC, because powerful optimizations, such as in-line code generation and loop enregistering, generate executables that are compact and efficient. The documentation even teaches you special coding techniques to squeeze every last bit of

speed out of your code.

Fast code isn't all you get. Under MS® OS/2, the 640K barrier is gone so you can write C programs as large as a gigabyte. You can call the operating system directly. Create more responsive programs (multiple threads allow program operations to overlap). And build Dynamic Link Libraries (DLLs) that can be shared, saving valuable memory. DLLs also allow your main programs to be smaller, so they load faster. You can even write a single Family API program that runs under both MS-DOS and MS OS/2.

The fastest possible way to create the fastest MS OS/2 programs possible.

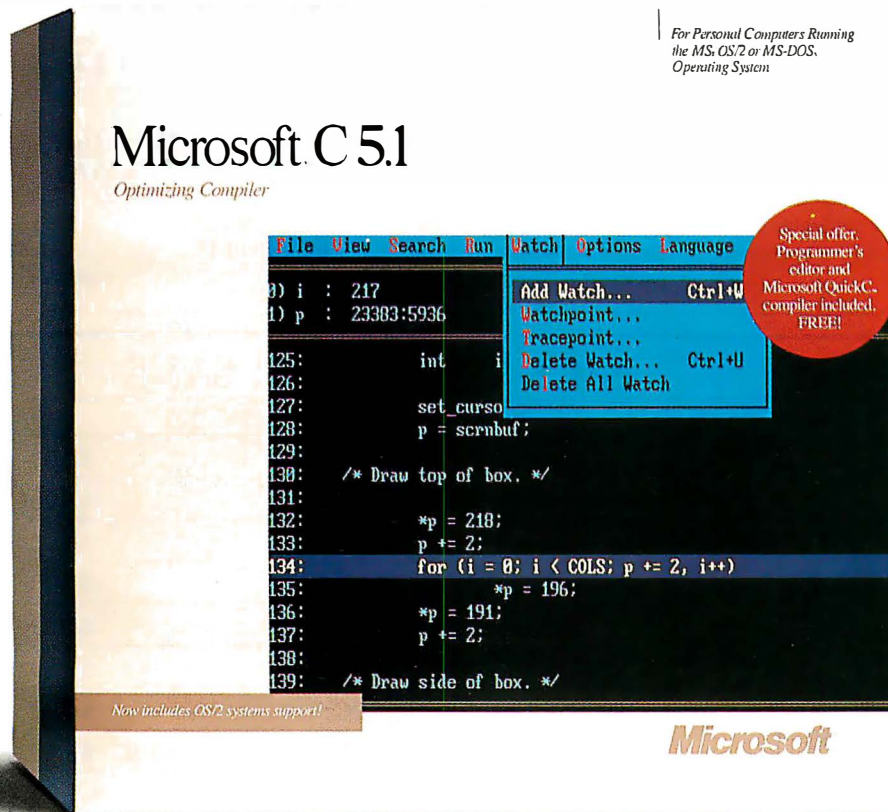

For Personal Computers Running the MS, OS/2 or MS-DOS Operating System

Microsoft C 5.1

Optimizing Compiler

Microsoft C Optimizing Compiler 5.1 Techbox

Compiler

- Optimizations that generate the fastest code for DOS and OS/2 systems.
 - In-line code generation.
 - Loop optimizations.
 - Elimination of common subexpressions.
- Full OS/2-system support to break the 640K barrier.
 - Family API programs that run under DOS and the OS/2 systems.
 - Write multithreaded programs and Dynamic Link Libraries.
- Small, medium, compact, large, and huge memory models.
- Mix models with NEAR, FAR, and HUGE keywords.
- Fast compilation (10,000 lines/minute) with Microsoft QuickC™.
- Fastest math, in-line 8087/80287 instructions, and floating-point calls.
- More complete support of proposed ANSI standard.
- Over 350 library functions, including a graphics library.

Microsoft CodeView

- Full OS/2 systems support.
 - Debug applications of up to 128 MB under the OS/2 systems.
 - Debug multithreaded programs and Dynamic Link Libraries.
- Source-level debugging for precise control over programs.
 - Dynamic breakpoints in the source.
 - Debug programs written in a variety of Microsoft languages.
 - Full symbolic display of C structures.
 - Interactively follow linked lists and nested structures.
 - Watch variables, memory, registers, and flags.

Other Utilities

- Fast linking (twice as fast as the C 4.0 version linker).
- OS/2 incremental linker – up to 20 times faster than a full link.
- OS/2- and MS-DOS reconfigurable programmer's editor.

Microsoft Editor is the first reconfigurable text editor for programmers that lets you develop under MS-DOS and MS OS/2. Under MS OS/2, multitasking lets you edit one file while you compile another, which cuts development time. You can even generate multiple compilations that report errors directly back into your source code.

Microsoft CodeView® is the highly acclaimed window-oriented source-level debugger that makes debugging not only fast, but extremely efficient. You can view program execution

while you watch variables and register values change. And under MS OS/2 you can debug multi-threaded applications, DLLs, and programs as large as 128 MB. The Microsoft C Optimizing Compiler 5.1, designed for the professional programmer. It's all the speed you need. Call (800) 541-1261.

Microsoft
Making it all make sense.

Microsoft, the Microsoft logo, MS, MS-DOS, and CodeView are registered trademarks of Microsoft Corporation.

Leave the Windows to Your Software

Programming in the Microsoft Windows environment can be difficult and time-consuming because you spend your time writing event handlers and responding to Windows messages. A CASE tool from CASEWorks was designed to make your life a little easier. CASE:W does most of the Windows programming for you, letting you concentrate on the application-specific parts of the program, according to the manufacturer.

CASE:W is an expert system with a knowledge base of Windows code sets and production rules. A prototyper, or front end, is included, which



CASE:W gives programmers easy access to the compiler command line.

lets you specify the characteristics you want for the program's main window and menu system. Then CASE:W automatically generates the program code files and make files.

The Windows controls that the program takes care of for you include menu bars, pop-up menus, and dialog boxes.

A Program Regeneration facility is included with the package. It carries forward

any code you add from one generation of an application to the next.

CASEWorks also announced plans for a CASE tool for Presentation Manager.

CASE:W runs on 80286- or 80386-based machines with at least 2 megabytes of RAM and Windows. You must have the Microsoft Windows Software Development Kit, the Microsoft C Compiler version 5.0 or higher, a make utility and linker, and a DOS- or Windows-compatible text editor. The company also recommends Microsoft's Code-View debugger.

Price: \$1495.

Contact: CASEWorks, Inc., One Dunwoody Park, Suite 130, Atlanta, GA 30338, (404) 399-6236.

Inquiry 1141.

continued

	1985	1986	1987	1988	1989
Jan.	\$4.00	\$6.00		\$6.00	\$6.00
Feb.	\$4.00	\$6.00	\$6.00		\$6.00
March	\$4.00	\$6.00	\$6.00	\$6.00	\$6.00
April	\$4.00	\$6.00	\$6.00	\$6.00	\$6.00
May	\$4.00	\$6.00		\$6.00	
June	\$4.00	\$6.00	\$6.00	\$6.00*	
July		\$6.00	\$6.00	\$6.00	
Aug.	\$4.00	\$6.00	\$6.00	\$6.00	
Sept.	\$4.00	\$6.00	\$6.00	\$6.00	
Oct.	\$4.00	\$6.00	\$6.00	\$6.00	
Nov.	\$4.00			\$6.00	
Dec.	\$4.00	\$6.00	\$6.00	\$6.00	

* Benchmarks Issue ½ Price

Check enclosed

Payments from foreign countries must be made in US funds payable at a US bank.

VISA MasterCard CARD # _____ EXP. DATE _____

SIGNATURE _____

The above prices include postage in the US. Please add \$.50 per copy for Canada and Mexico; and \$2.00 per copy to foreign countries (surface delivery). Please allow 4 weeks for domestic delivery and 12 weeks for foreign delivery.

European customers please refer to Back Issue order form in International Advertising section of book.

NAME _____

ADDRESS _____

CITY _____ STATE _____ ZIP _____

BACK ISSUES FOR SALE

SPECIAL ISSUES and INDEX

BYTE '83-'84 INDEX	\$3.00
BYTE 1985 INDEX	\$3.00
BYTE 1986 INDEX	\$3.00
BYTE 1987 INDEX	\$3.00
1985 INSIDE THE IBM PCs	\$4.00
1986 INSIDE THE IBM PCs	\$5.00
1988 INSIDE THE IBM PCs	\$6.00
APPLICATIONS SOFTWARE TODAY SPECIAL	\$4.00

Circle and send requests with payments to:

BYTE Back Issues
One Phoenix Mill Lane
Peterborough, NH 03458
(603) 924-9281



Your compiler needs **.RTLink™** to give you the speed and power you've been looking for.

Whatever MS-DOS compiler you use, **.RTLink** can reduce the time you spend developing programs and provide you with vital statistics that will help you optimize your program's performance.

.RTLink is linking technology at its finest, providing the fastest and most powerful overlay and static linking capabilities available. **.RTLink's** new **PRFile** feature profiles the performance of your program and puts vital performance statistics at your fingertips. These statistics provide valuable information that can be used to increase your program's performance.

Also, **.RTLink's** easy-to-use Run Time Library feature lets you significantly reduce the amount of disk space needed for storage and shipping of your programs.

The **PRFile** feature of **.RTLink** gives you access to program performance statistics in greater depth and detail than ever before available, with no changes to your source code. Now you can see where your program spends its time, and what it is doing, at timing intervals that are adjustable to thousandths of a second. Another utility, to cross-reference the raw statistics for easy analysis, is provided with source code so you can customize the analysis report.

When you consider the speed, power, versatility, and control features provided by **.RTLink** that are not available in any other linker, don't you think it's time you got a new linker?

Our Guarantee: Try **.RTLink** for 30 days. If you are not completely satisfied, simply return it for a refund of the purchase price.

Order yours today for \$195.00

Phone in your order using Visa, Mastercard, or C.O.D., or send a check for \$195.00 to:

For Phone Orders call (713) 460-5600

Pocket Soft, Inc.
7676 Hillmont, Suite 195
Houston, Texas 77040

NOTE: Texas Residents include 7% sales tax.

Circle 219 on Reader Service Card

Trademarks: All Pocket Soft products are trademarks of Pocket Soft, Inc. Other brand and product names are trademarks or registered trademarks of their respective holders. © 1989 Pocket Soft Inc.

Sylva Upgraded

Interactive screen prototyping and COBOL code generation have been added to the Sylva System Developer CASE tool, a program that automates analysis and design techniques.

The prototyping facility lets you paint screens and create dialogues that look and behave like an interactive system, according to Cadware. After you've approved of the prototype, you can quickly generate the COBOL screen-handling source code.

To run the Sylva System Developer, you need an IBM PC with DOS 3.0 or higher and at least 640K bytes of RAM. A mouse is recommended along with an EGA

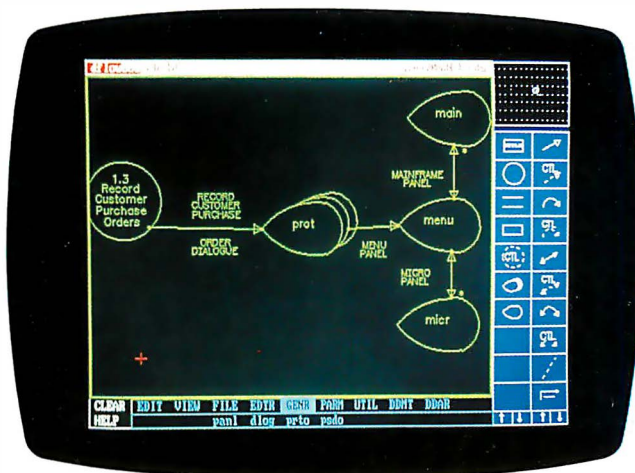

Paint screens and create dialogues with Sylva's screen prototyping capability.

board.

Price: \$3495.

Contact: Cadware, Inc., 50 Fitch St., New Haven, CT 06515, (800) 223-9273; in Connecticut, (203) 387-1853.
Inquiry 1144.

MicroStep

MicroStep is a CASE tool that produces C source code and executable pro-

grams from your graphics specifications, according to SysCorp. The program features an interactive graphic design environment, automatic specification analysis, generation of executable code, and the production of technical documentation. You can use the program to generate PC applications or as a rapid prototyper.

The program features a mouse-driven interface.

MicroStep runs on the IBM PC with 640K bytes of RAM, DOS 3.1 or higher, a 20-megabyte hard disk drive, an EGA or Hercules card, and a mouse.

Price: \$5000.

Contact: SysCorp International, 9420 Research Blvd., Suite 200, Austin, TX 78759, (512) 338-0591.
Inquiry 1143.

Your job is *computing* . . . Why does your keyboard emulate a typewriter?

Your PC keys have typewriter legends, not the specific commands you need! **Solution:**

Hooleon's SnapCap KeyCaps™ or non-slip adhesive Keytop Label kits, imprinted with the software commands! **Cut training costs** with Word Perfect 5.0™ or 5251 Emulation KeyCaps for the IBM® 101-Key Keyboard. **Customize your keyboard** with releasable keys for IBM®, Cherry™, Wyse™ and Key Tronic™. Choose from non-slip Keytop Labels supporting Word Perfect™, DisplayWrite™, Multi-Mate Advantage™, Microsoft Word™, Data Entry, Language Conversions and more. **We Custom Imprint Keys and Labels to your specs!**

Call for your **FREE CATALOG!**

To order call:

602 634-7515 or FAX: 602 634-4620

From the Leader in Keytop Innovations . . .

Hooleon
CORPORATION

P.O. Box 201, Dept. BYTE,
Cornville, AZ 86325



QUICK ACCESS EASY EDIT



THE MATCHMAKER
GOLDEN BOW SYSTEMS

TM

A MATCH FOR YOUR FILES—find disk information fast, no matter how it's formatted. No need to index or keyword your files—just describe what you want in plain English or regular expressions, and it's on your screen *fast*.

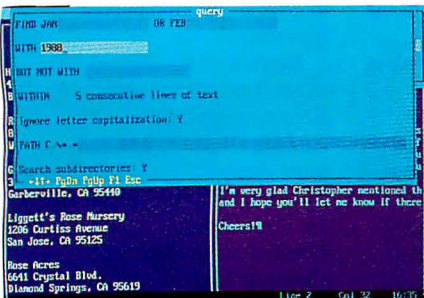

The query panel is Vq's window into your disks.

A MATCH FOR YOUR PATH—quickly search a file, a whole disk, or anything in between to find all the files with a match to your search pattern, then display each match in full context!

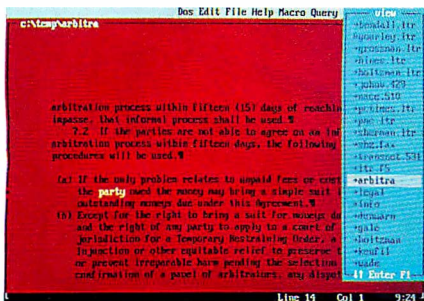

After a query, Vq lists the files containing the target pattern and displays the matching text, highlighted in context.

WHEN YOU FIND IT, USE IT with Vq's full-featured editor or your own word processor, compiler, or custom macro.

A MATCH FOR YOUR CREATIVITY—expand your creativity into a screenful of windows for different files or different parts of a file. Zoom them, compare them in parallel, or copy-and-paste to a new file.

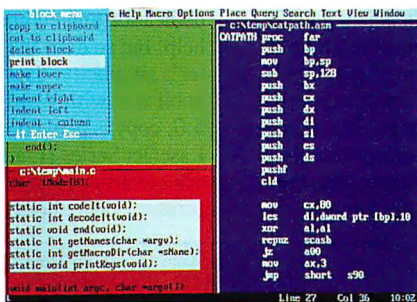

Vq's Block command menu is pulled down for processing the marked block of text.

A MATCH FOR YOUR STYLE—everything you want for creating and manipulating text, plus a few things you never thought to ask for—paragraph formatting, text centering, auto-indent, search-and-replace, copy, cut, delete or print blocks—*effortlessly!*

A MATCH FOR YOUR DISPLAY—25, 43, or 50 line display modes, and you pick the screen colors!

A MATCH FOR YOUR MOUSE—full mouse support with pull-down command menus means you don't have to remember *anything*. All Vq's power is delightfully accessible—just point and shoot!

A MATCH FOR SYSTEM FAULTS—while you're working, *auto-save* is working too, so you can automatically start each session where the last one ended—even if it ended *unexpectedly!*

A MATCH FOR YOUR APPLICATIONS—add Vq's access and editing talents to the applications you know and love.

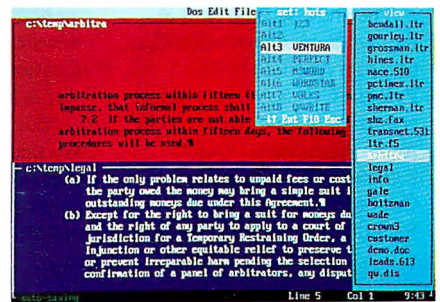

The small-pull down menu lists Vq's preconfigured Hot Links to other applications.

Vq comes with Hot Links to popular applications, and creating more is a snap. Pass your desktop publisher the file you created, format it, print it, then return to Vq to find your sales summary and jump-start your spreadsheet program, or write brilliant code and Compile-and-display-next-error. Vq shrinks to just 7K bytes during linkage and gives your applications room to run!

A MATCH FOR YOUR CHORES—teach Vq whatever you do over and over. Vq's macros learn any input sequence for flawless playback at your command, for infinite customization!

Vq operates with OS/2 or DOS 3.0 or higher in IBM-compatible systems with 256K bytes.

Vq is a trademark of Golden Bow Systems

SEE YOUR DEALER OR CALL TOLL-FREE

(800) 284-3269

\$270

GOLDEN BOW SYSTEMS

M/C VISA
\$5 US shipping
CA orders add 7%

2870 5th Avenue
San Diego, CA 92103

FAX (619) 298-9950

(619) 298-9349

TELEX 201520 GBS UR

Circle 478 on Reader Service Card (DEALERS: 479)

APRIL 1989 • B Y T E 96PC-1



WHAT'S NEW

PACIFIC

West Coast Government Computer Show

For the first time, the Federal Computer Conference (FCC) and the Defense and Government Computer Graphics Conference (DGC) will be held on the West Coast. The show will feature an exposition in hardware, software, peripherals, systems integration, graphics, maintenance, and other services.

The show will be held at the Anaheim Convention Center from April 25 to 28.

Price: FCC: \$395 for federal government employees, \$495 for nonemployees; DGC: \$395 and \$495, respectively.

Contact: National Council for Education on Information

Strategies, 7315 Wisconsin Ave., 901 W, P.O. Box 41045, Bethesda, MD 20814, (800) 343-6944; in Maryland, (301) 961-6575.

Inquiry 920.

Sacra Blue: Keeping It Simple

An oft-quoted expression that your car is an extension of your personality can be applied to the users group newsletter: The appearance and content of your group's newsletter is a pretty good indication of what the group itself is accomplishing.

Most club presidents will say that although BBSes, meetings, and volunteer troubleshooters are important, the newsletter is the group's

main drawing card. For members who don't have a modem and can't attend all the meetings, the newsletter is the primary, if not the only, source of group information.

The problem is, how do you publish an attractive, timely publication that serves all the group's needs without burning out your editor?

Sacra Blue, the publication of the Sacramento PC Users Group (SPCUG), averages 80 pages a month and is one of the better news magazines put out by users groups. According to editor Tony Barcellos, dedication and enthusiasm help, but so does the newsletter's simplicity. Sacra Blue is published with WordPerfect 5.0, copy is printed on an HP LaserJet Series II, and the ads are dropped in at the printer. The editors don't use

desktop publishing programs such as PageMaker, but they still produce a highly readable, professional news magazine.

By avoiding the extra steps of desktop publishing, Barcellos said Sacra Blue has only a two-week lead time from author deadline to actual shipment of the month's edition. He noted, "It's not state of the art, like a PC Monitor [the Capital PC Users Group journal], but it's a lot more hassle to go that [desktop publishing] route."

Barcellos also said the key to good newsletter content is attracting the right mix of talented amateurs and professionals.

The SPCUG has about 2500 members.

Price: Annual dues, \$25.

Contact: SPCUG, Member-

continued

AutoKey 400 programmable macro keys !

Simplify DOS, D-base, Lotus 1-2-3.
Boost your CAD performance.
Automate word processing.

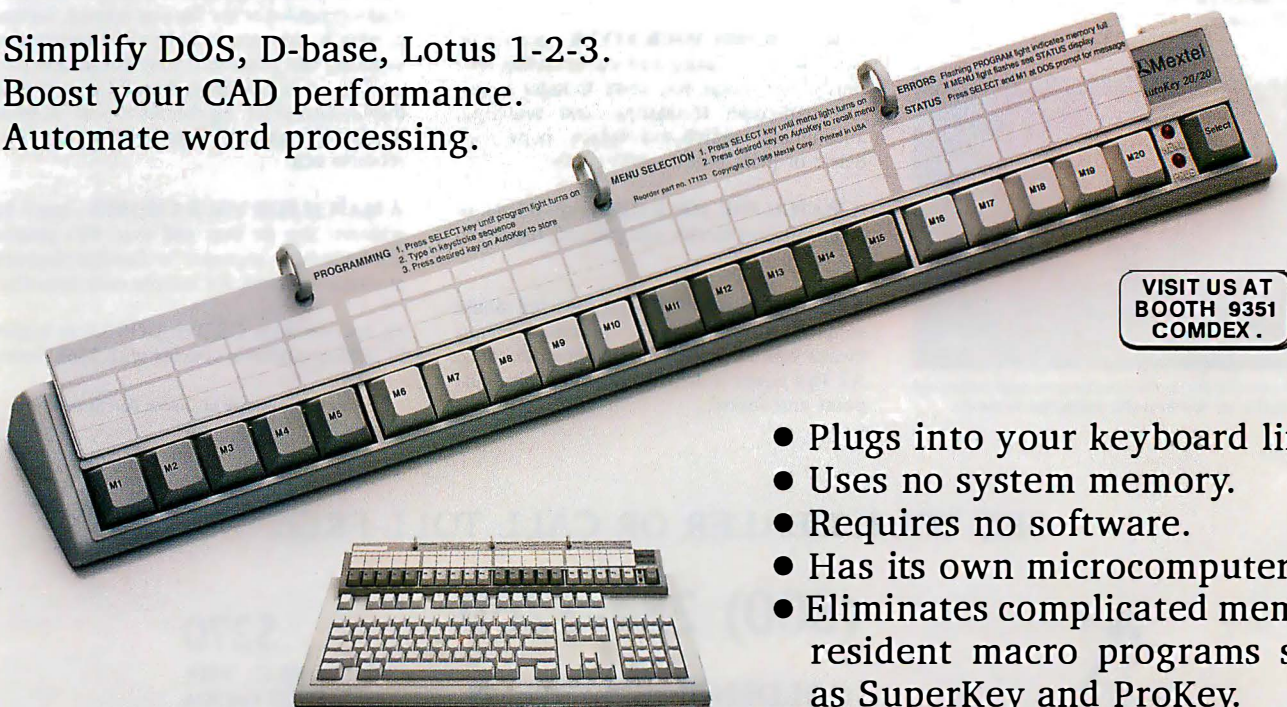

VISIT US AT
BOOTH 9351
COMDEX .

- Plugs into your keyboard line.
- Uses no system memory.
- Requires no software.
- Has its own microcomputer.
- Eliminates complicated memory resident macro programs such as SuperKey and ProKey.

Mextel Corp. 159 Beeline Road
Bensenville, Illinois 60106 *Circle 482 on Reader Service Card*
AutoKey is trademark of Mextel Corp. All other product names are trademarks of their respective manufacturers. ©1989 MEXTEL CORP.

Call 1-800-888-4146
(inside IL call 312-595-4146)
Prices start at \$139.00 Visa/MC/AmEx.

THE WORLD OF ATARI

AT THE
Disneyland Hotel

PRESENTED BY ST WORLD

APRIL 22-23, 1989
SATURDAY 10:00 AM to 6:00 PM
SUNDAY 10:00 AM to 5:00 PM

Discount
Tickets are
available at
Mid-Cities!

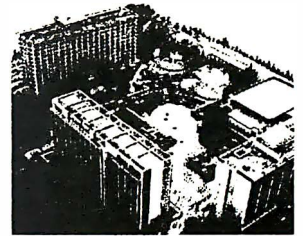

Watch for our show specials!

POSTSCRIPT COMPATIBLE DESKTOP PUBLISHING SPECIAL

Mega 4 Monochrome System
SLM804-PVC Postscript
Compatible Laser Printer
50 Fonts
MegaFile 30 Hard Drive
Timeworks Publisher ST

**PACKAGE PRICE
ONLY \$4195**

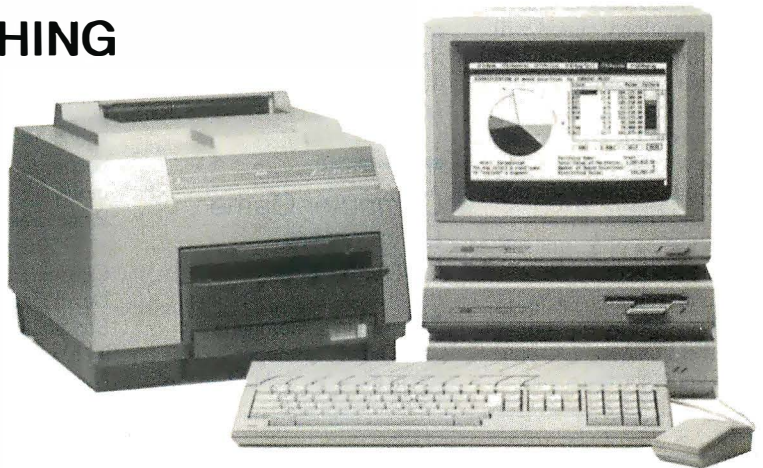

1040 ST SPECIAL

1040 ST Color System

ONLY \$999.95

1040 ST Mono System

ONLY \$799.95

PLUS

MEGA 2 Mono System \$1499
MEGA 2 Color System \$1699
MEGA 4 Mono System \$2399
MEGA 4 Color System \$2599
SLM 804 Laser Printer \$1499



All Dr. T's Software



**30%
OFF**

Plus

C-Lab Notator, Creator
Hybrid Arts Edit Track, SMPTE Track
Steinberg Pro 24, 12, Synthworks
DigiDesign Sound Designer
IN STOCK!

MID-CITIES COMP/SOFT

9406 Flower St., Bellflower, CA 90706
(213) 867-0626 (213) 867-8994

Store Hours:
Tue.-Fri. 10 a.m. to 7 p.m.
Sat 10 a.m. to 6 p.m.
Closed Sun. & Mon.:

WE ACCEPT
VISA / Master Card / Discover
American Express

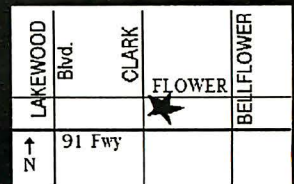

Authorized Atari Dealer & Service Center

ship Director, P.O. Box 685, Citrus Heights, CA 95611, (916) 386-9865.

Inquiry 921.

Robotics and Automation Conference

The IEEE Robotics and Automation Council will hold its annual conference at the Registry Resort in Scottsdale, Arizona, from May 14 to 19. During the conference, tutorials will be given on AI applications, multisensor integration and fusion, theory and application of redundant robots, autonomous mobile robots, and robot vision systems. Two all-day sessions will be held on May 19—one on parallel algorithms and

architectures in robotics, and one on the integration of AI and robotic systems.

The tutorials and workshops will begin on Sunday, May 14.

Price: Conference: \$185 for IEEE members; \$230 for non-members; \$100 for students. Workshops, \$75 and up. Tutorials, \$100 and up.

Contact: Robotics and Automation, P.O. Box 3216, Silver Spring, MD 20901, (407) 483-3037 or (301) 434-1990.

Inquiry 919.

Computer Game Developers' Conference

The Third Computer Game Developers' Conference will be held May 7 to

8 at the Sunnyvale Hilton in California. Conference sessions and roundtable discussions will be devoted exclusively to computer entertainment issues and will feature about 24 sessions in two tracks.

Some of the planned sessions include the process of building games, artificial personalities, publisher/developer relationships, the entertainment software marketplace, future game technologies, animation, the press and games, theft protection, becoming a publisher, and more.

Price: Postmarked by April 1, \$150; by May 1, \$175.

Contact: Computer Game Developers' Conference, P.O. Box 50282, Palo Alto, CA 94303, (415) 949-3379.

Inquiry 923.

Unix Executive Symposium

The international association of Unix systems users, /usr/group, will sponsor, with Patricia Seybold's Office Computing Group, a Unix executive forum. The symposium is aimed at executives of large end-user organizations such as Fortune 500 companies and the government.

The conference will take place from April 26 to 28 at the Santa Barbara Biltmore Resort Hotel.

Price: \$995.

Contact: /usr/group, 2901 Tasman Dr., Suite 201, Santa Clara, CA 95054, (408) 986-8840.

Inquiry 922.

Remarkable Products at Splendid Prices

ATI VGA Wonder w/Mouse 256K	\$ 345	256K-12 x 8 SIMM (Mac)	\$ 80
APPLE All—Discounts up to 32% (really)		256K-10 x 8 SIMM (Mac)	\$ 90
Laserprinter II-NT	\$3600	256K-08 x 9 SIMM	\$ 115
Mac Plus	\$1375	1M-12 x 8 SIMM (Mac)	\$ 200
Mac SE	\$2295	1M-10 x 8 SIMM (Mac)	\$ 210
Mac SE/30	\$3200	1M-10 x 9 SIMM Static	\$ 430
Mac II	\$3550	1M-08 x 9 SIMM Static	\$ 470
Mac II-X/4	\$5070	Microsoft Word 4.0	\$ 265
Autocad v. 10	\$2359	Miniscribe	
Compaq All models available		MS3085 hh 22ms, 85MB	\$ 610
SLT/286, 20 M	\$3975	MS3180 hh 17ms, 160MB	\$1120
386/25 Deskpro, 60M	\$5975	NEC Multisync 3D	\$ 665
GammaLink All models—up to 30% off		Panasonic All models, including FAX	
HP Also scanners, plotters; palpable savings		Qume ScriptTen Postscript laser — Mac	\$3300
Laserjet II w/toner	\$1690	Samsung All models	
Laserjet II-D w/toner	\$2795	Seagate All models	
Holmes Microsystems		Sigma Designs All models 30% off	
Modem/FAX internal for Toshiba	\$ 450	Laservision Plus 15" w/card	\$1395
Intel		Toshiba	
80287-10	\$ 265	T1000 512K, LCD, 1-720K	\$ 695
80387-20	\$ 470	T1200F/FB 1MB, LCD, 2-720K, 7 hour	\$1395/\$1595
SYP302 386-25 computer	\$3550	T1200H/HB same, 1-720K, 20MB	\$2195/\$2395
Macintosh Software Most major brands		T1600 1M, LCD, 1-1.44MB, 20MB, 4 hour	\$3200
Quark Express	\$ 495	T3100e 1M, Plasma, 20MB	\$2800
Megahertz		T3200 1M, Plasma, 40MB	\$3495
2400 baud internal modem/Toshiba	\$ 195	T5100 2M, P1, EGA, 40MB	\$4300
Ethernet for Toshiba	\$ 450	T5200-40 2M, P1, VGA, 40MB	\$6650
Memory		Ventura Publisher v.2.0	\$ 439
256K-10 DIP	\$ 8	Zenith All — 34% off	
256K-10 x 9 SIMM	\$ 100	Supersport 286, 20M	\$3300

SEVERE

DISCOUNT
COMPUTERS

Severe Discount Computers, 14098 E. Firestone Boulevard, Computer City, CA 90670

(213) 802-7470 FAX #(213) 921-9597

California orders add sales tax. Call to confirm price and availability.



THE REWARDS OF WORKING TOGETHER

OSF Operating system of the future.

As a founder of OSF, Digital indicated to the industry its corporate support for open systems. Now, we are investing heavily to ensure that Digital's customers get the highest quality, best cost-performance open systems available.

Digital's VAX/VMS* operating system is an acknowledged leader among proprietary operating systems. We're aggressively developing OSF-compliant software which will be of equivalent stature.

The recent industry developments in open systems software have created a ground-floor opportunity. Digital's Seattle Software Engineering Group is now seeking outstanding architects and developers to help us develop leadership operating

system software. Those who join us now will participate in the establishment of a new software dynasty.

You'll need 8-10 years' design through implementation experience in one or more of the following:

- Major operating systems, especially UNIX†
- OLTP
- Distributed systems, client server model
- Architectural design
- Modern development environment
- Hierarchical Storage Management
- Software Test
- Systems Administration

For consideration, or more information about this exciting opportunity, please send your resume to: **L. Taylor, Manager, Dept. 0401-9800, Digital Seattle Engineering Group, Digital Equipment Corporation, 14475 NE 24th, Bellevue, WA 98007.**

Proof of legal right to work in the U.S. is required.

We are an affirmative action employer.

**Digital
has
it
now.**

*Trademark of Digital Equipment Corporation
†Trademark of AT&T

P11. THE POWER BEHIND THE MAGIC...only \$79.95

With P11, everyone from novice artists to professional programmers can easily create animated graphics for . . .

- Presentations.
- Training programs.
- Educational programs.
- Games
- Cartoons
- Anything you can imagine

Order Today. . .

DEALER INQUIRIES INVITED

P11 Enterprises
P.O. Box 5185 Dept. B
Bridgeport, CT 06610

90 Day Money Back Guarantee

"The versatility of this program is unrivaled by anything I've ever seen. It could be used to create almost any demonstration or tutorial" —**Big Blue Disk #13, Oct. 1987**
"A rich array of creative animation possibilities."

—PCM (for TANDY Users), Nov. 1987

"The possibilities for education, advertising, and training are endless." . . . "An amazing value."

—UPTIME FOR THE PC, Vol. 1, #5

"Easy to learn and use. Simple, powerful, affordable"

—BOSTON COMPUTER SOCIETY
EDUCATIONAL SPECIAL INTEREST GROUP

CALL (203) 366-0258

In Canada call BDT Int'l (416) 253-8068

\$3.50 Postage and Handling.

CT Residents please add sales tax—\$4.50





FOUR GUYS COMPUTERS IN HOUSE SERVICE & SUPPORT

“INVADING THE COMPUTER WORLD”

136 WEST 32ND ST. (BTWN. 6-7 AVES.), NEW YORK, NY 10001

PHONE ORDERS ACCEPTED
IN NYS (212) 643-3900
ON SAT (212) 239-4350

1-800-242-4GUY

IF YOU DON'T SEE WHAT YOU WANT, ASK FOR IT.

FREE GIFT w/Every Order

OPEN 7 DAYS
MON-SAT 10-8
SUN 10-6

CALL & ASK US TO BEAT YOUR BEST PRICE

COMPAQ DESKPRO 286
12 MHz • 1.2 Floppy Drive • 40 MB H.D. **\$1975**

COMPAQ DESKPRO
386S VGA 40 MEG H.D. **\$3199**

HYUNDAI 286C 640K
30 Meg Hard Drive & More!
18 Month Warranty **\$1199**

SANYO 286 AT COMP.
1 MEG on MB - 1.2 Floppy DOS Included **\$1199**

SANYO XT MB16
1 Floppy • 640K **\$499**

AST
AST PREMIUM 286
10 MHz • 512K • 1.2 Floppy Seagate 40 MB H.D. **\$1699**

Commodore Colt
2 Floppies w/CGP/MGP and monitor **\$749**

FOUNTAIN TECH FAST 12 MHz
100% IBM Compatible • 286/12
20 Meg Hard Drive
101E Keyboard **\$1299**

FOUNTAIN TECH 386/16
1 Meg RAM 1.2 Floppy
101 Keyboard **\$1699**

AMIGA

All Commodore Amiga products in stock — Greatly Discounted. Call & Will Beat Any Price.

APPLE COMPUTERS

Apple IIGS
Apple IIC Plus
Macintosh SE
MAC II
MAC SE 30 NEW **IN STOCK**

Amiga is a registered trademark of Commodore Amiga, Inc.

PACKARD BELL XT
2 Floppies MGP/CGP mono monitor **\$799**

ACTION PRINTERS BY EPSON ALL IN STOCK

LAPTOP COMPUTERS

TOSHIBA T-1200 IN STOCK
TOSHIBA T-1200 FB CALL
TOSHIBA T-1200 HB CALL
TOSHIBA 1600 CALL
TOSHIBA 3200 CALL
TOSHIBA 5100 CALL
TOSHIBA 5200 CALL
ZENITH 184-1 (2 drives) CALL
ZENITH 184-20 CALL
ZENITH SUPERSPORT 286 CALL
ZENITH SUPERSPORT 386/40 CALL
IN STOCK CALL
NEC MULTISPEED HD CALL
MITSUBISHI 286 CALL
NEC ULTRALITE CALL

Panasonic
Office Automation

2 Year Warranty on all Panasonic Printers

Pan. KXP1180 IN STOCK
Pan. KXP1191 IN STOCK
Pan. KXP1124 CALL
Pan. KXP1524 \$519.95
Pan. KXP1592 \$379.95
Pan. KXP1595 \$429.95
Brother HL8 \$1799.00
HP LaserJet III \$1595
Panasonic Laser \$1399.90

ALL PRINTER PRICES VALID ONLY WITH PURCHASE OF CABLE

MONTHLY SPECIALS

Ext. PC Comp. 1200
Modern \$99.00
Citizen MSP10 \$229.00
Citizen MSP15 \$299.00
FASTRAX BY BRIDGEWAY \$49.95

COMPLETE PC ALL IN STOCK
ANSWERING MACHINE
FAX CARD 2400
FAX CARD 9600
SCANNER

brother Authorized Dealer
Brother 1509 In Stock
Brother 1709 In Stock
Brother 1109 In Stock
Brother HR-20 \$339.00
Brother HR-40 \$529.00
Brother Twinwriter In Stock

MODEMS MICE
Prometheus Genius \$39.95
US Robotics Logitech
H Hayes Microsoft
Practical Peripherals ALL IN STOCK
Novation STOCK

FAX MACHINES
Scanners CALL

FULL ON-LINE TECHNICAL SUPPORT

ALL OUR PRODUCTS ARE FACTORY FRESH WITH FULL WARRANTY. NOT RESPONSIBLE FOR TYPO ERRORS. ALL PRICES IN THIS AD CASH ONLY. 10 DAY RETURN WITH ALL ORIGINAL PACKAGING AND RETURN AUTHORIZATION. SHIPPING AND HANDLING EXTRA. THIS AD SUPERCEDES ALL OTHER ADS. PRICES AND AVAILABILITY SUBJECT TO CHANGE WITHOUT NOTICE. DEPARTMENT OF CONSUMER AFFAIRS #800105 #805694

We have more LaserJet Fonts Than Anybody!



272 Scalable Fonts for HP LaserJet+, II

and compatible printers. With *Digi-dust!*, you can quickly and easily make LaserJet soft fonts in any size, from 3.0 - 720.0 pts. You can also slant, expand, rotate, flop, and reverse any font. Make portrait and landscape fonts, with full or partial character sets.

You can use DIGI-FONTS with all programs which support soft fonts, including WordPerfect, Ventura, PageMaker, 1st Publisher, WordStar, PCWrite, and MicroSoft Word.

Basic Set

8 typefaces & *Digi-dust!* program
Reference manual, Typeface catalog

\$69.95 plus \$3 shipping

Complete Set

Basic Set + Typeface Library (264 typefaces)

\$419.90 plus \$6 shipping

System Requirements

IBM PC/XT/AT or compatible
Hard disk, 5 1/4" floppy
MS-DOS 3.0 or higher
384K RAM Memory
HP LaserJet+, or II or
compatible printer.

Order Today!
(800) 242-5665

DIGI-FONTS, INC.

3000 Youngfield Street, Suite 285
Lakewood, Colorado 80215
(303) 233-8113 FAX (303) 526-9502

VISA, Mastercard, American Express, COD or prepaid orders gladly accepted. Personal checks welcome. Sorry, no billing. Please add \$3 for COD orders. We ship UPS 2nd day delivery unless otherwise requested. We are generally open Monday - Friday, 7 am - 6 pm and Saturdays, 8 am - 3 pm MST. Give us a call, and if we're here, we will be happy to take your order and answer any questions we can. This ad set entirely with DIGI-FONTS' Typefaces. Trademarks are the property of their owners.

Quality In... Quality Out



No matter how well acquainted you are with making important personal computing decisions—decisions that may involve hundreds of thousands of dollars—the value of those decisions is only as good as the value of your information. Without quality information—it's hard to make quality decisions.

BYTEweek, McGraw-Hill's new weekly newsletter for professionals in the personal computer industry, is devoted to giving you that quality information through its timely and compact one-stop news format.

This new publication provides you with short, easy-to-read selections of the most important news and technological developments of the past week. And BYTEweek interprets this news with in-depth commentary and analysis.

Subscribe to BYTEweek for quality information. Remember, quality in...quality out.

Subscribe now and take advantage of the special one-year charter subscription rate of \$395 (\$495 outside the U.S. and Canada). This special price represents a savings of \$100 off the regular rate. Your subscription includes 50 issues plus a free three-month subscription to BIX—a \$49 value. Through BIX you can directly access the Microbytes Daily news service and communicate with other BIX users.

Don't miss this opportunity! In the U.S., call BYTEweek's toll-free number: **1-800-258-5485**, in N.H. and outside the U.S., call: 1-603-924-9281.

BYTEweek offers a *money-back guarantee* if you're not completely satisfied.

BYTEWEEK 

News and Analysis for Professionals in the Personal Computing Industry
One Phoenix Mill Lane, Peterborough, NH 03458

FINALLY, ONE DISC DRIVE SOURCE

HARD DRIVES

ST506 Interface - 3 1/2" Hlf. Ht.

Seagate ST125	20mb/28ms	\$ 249
Seagate ST138	30mb/28ms	299
Mitsubishi MR535	42mb/22ms	525
Toshiba MK134FA	42mb/25ms	495

ST506 Interface - 5 1/4" Hlf. Ht.

Seagate ST225	20mb/65ms	\$ 225
Seagate ST238	30mb/65ms	249
Miniscribe 3650	40mb/65ms	349
Seagate ST251	42mb/40ms	355
Seagate ST251-1	40mb/28ms	445
Seagate ST277R	65mb/40ms	445

ST506 Interface - 5 1/4" Full Ht.

Micropolis 1325	72mb/28ms	\$ 695
Seagate ST4096	80mb/28ms	599
Maxtor XT1140	120mb/28ms	1,625
Newbury Data 1140	120mb/25ms	1,395
Maxtor XT2190	150mb/28ms	1,895

SCSI Interface - 5 1/4" Full Ht.

Newbury Data 3170S	147mb/19ms	\$1,595
Maxtor XT3380S	244mb/16ms	1,895
Siemens 2300	310mb/16ms	2,295
Newbury Data 3280S	320mb/19ms	2,495
Maxtor 4380S	320mb/16ms	2,795
Siemens 4420	383mb/16ms	2,495
Maxtor XT8760S	660mb/16ms	5,195

ESDI Interface - 5 1/4" Full Ht.

Newbury Data 4175E	147mb/19ms	\$1,495
Siemens 1300	310mb/25ms	2,295
Newbury Data 4380E	320mb/19ms	2,295
Maxtor XT4380E	320mb/16ms	2,795
Siemens 4410	383mb/16ms	2,495
Maxtor XT8760E	660mb/16ms	4,995

**1 YR. WARRANTY
ON ALL PRODUCTS
EXCEPT AS NOTED.**

FLOPPY DRIVES

3 1/2" Hlf. Ht.

Teac	720k	\$ 110
Fujitsu	720k	105
Teac	1.44mb	120
Fujitsu	1.44mb	115

5 1/4" Hlf. Ht.

YE-Data	360k	\$ 69
Alps IBM	360k	69
Teac FD55BR	360k	79
Fujitsu	360k	75
Teac FD55GFR	1.2mb	115
Fujitsu	1.2mb	110

TAPE DRIVES

TANDBERG 1/4" Tape Drives

Mdl. 3620	60mb/SCSI	\$ 645
Mdl. 3610	60mb/QIC-02	645
Mdl. 3640	125mb/SCSI	795
Mdl. 3630	125mb/QIC-02	795
Mdl. 3660	150mb/SCSI	895
Mdl. 3650	150mb/QIC-02	895

IBM PS/2 KITS

360k Floppy w/Case & Cable	\$ 210
1.2mb Floppy w/Case & Cable	250

CONTROLLERS

Mini Micro Floppy, 1.2mb	\$ 69
"Big" Floppy, 360k	59
WD1 002-WX1 Tandy	99
WD-WXT-GEN	79
WD1003-WA2 AT	149
ADAPTEC 2072A XT RLL	99
XEBEC 1210, XT, 10-20mb only	59
DTC 5287, AT RLL	195
Perstor 200 Series, AT (8 Bit)	225
Perstor/Sequel SQ6180F, AT (16 Bit)	325
LCS 6620, 16MHz, AT	149
Data Master 44-800 - 3 1/2", 5 1/4", 8" Floppy	79
SCSI Controller, Future Domaine TMC841 (Kit)	350
Omti 8620, ESDI Controller	295
WD1 007-WA2, ESDI, AT (HD & FI)	325
WD1007-WAH, ESDI, AT (HD)	315

CABLES

XT Cable Set	\$ 15
AT Cable Set	15

DRIVE CASES

Hard Drive with Power Supply	\$ 165
Floppy Drive with Power Supply	99

- Thousands of disc drives in stock, call or write for brochure.

SPECIAL KITS FOR IBM AT & COMPATIBLES

Formatted capacity

84mb - ST506	\$ 695
175mb - ESDI	1,395
230mb - ESDI	1,695
320mb - ESDI	1,995

**KIT INCLUDES:
DISC DRIVE
CONTROLLER
SOFTWARE
INSTRUCTIONS**

- 90 DAY WARRANTY, LIMITED QUANTITIES

HARD DRIVE REPAIR SPECIAL

SPECIAL REPAIR DISCOUNT COUPON

90 day Warranty on all repairs.

HARD DRIVES

Capacity Flat Rate SPECIAL

10-19mb	\$99	\$89.10
20-30mb	\$125	\$112.50
31-40mb	\$150	\$135.00
41-49mb	\$175	\$157.50
50-85mb	\$210	\$189.00
86-120mb	\$275	\$247.50
121-150mb	\$325	\$292.50
Test & Evaluation	\$25	

SHIPPING YOUR DRIVE FOR REPAIR

Pack your drive carefully and well protected in a sturdy shipping box. Include with the shipment a note with your name, address, daytime telephone number and a brief description of the problem with the drive.

jb TECHNOLOGIES, INC.

21011 Itasca St. #F
Chatsworth, CA 91311

Telephone (818) 709-6400

COUPON MUST BE SENT WITH DRIVE

VALID THROUGH APRIL 30, 1989

jb TECHNOLOGIES, INC.

21011 Itasca St., #F
Chatsworth, CA 91311

Circle 481 on Reader Service Card

Telephone: (818) 709-6400

Telex: 678953

FAX: (818) 341-2935

- Corporate, Government and School POs welcomed.
- Visa or Mastercard welcomed.
- COD, Cashier's Check or Money Order.
- Personal Check - Shipment after Clearance.
- California residents must add applicable sales tax.
- All prices subject to change without notice.

Hard Disk Drive for the Mac Has Track Cache

The MacBottom HD84, an 84-megabyte hard disk drive for the Macintosh Plus, SE, and II, features a 1-to-1 interleave ratio with a 19-ms average access time and a track cache that anticipates the Mac's next request for data and stores it on the drive's controller card. According to Personal Computer Peripherals Corp. (PCPC), with the track caching enabled, the hard disk drive allows an access time of as low as 0 seconds.

The HD84 is 2 inches tall and weighs less than 5 pounds. The drive ships fully formatted and ready to run and includes print spoolers; FloppyCopy, a disk duplicator program; and Eureka!, PCPC's desk accessory for locating misplaced files. The drive also ships with HFS Backup 3.0, an archive and restore program that's MultiFinder and TOPS compatible.

Price: \$2195.

Contact: Personal Computer Peripherals Corp., 4710 Eisenhower Blvd., Building A4, Tampa, FL 33634, (800) 622-2888; in Florida, (813) 884-3092.

Inquiry 904.

Accounting Software for Small Businesses

Phoenix Phive's Payroll 2 accounting program, a new version of the company's SBAssistant Payroll program, is for small companies with up to 200 employees.

Payroll can handle weekly, biweekly, and monthly payroll. The new version's enhancements include after-the-fact payroll, handling city



The HD84 can fit in your briefcase.

taxes and 401(k) contributions, tax tables that you can modify, and the ability to accept time in hours and minutes as well as in hours and fractions of hours.

The program calculates Federal, State, FICA, and disability insurance, and city withholdings. It can also maintain personnel history and print paychecks and W-2 forms. Payroll can handle nine types of earnings: regular, overtime for first overtime or second shift, overtime for second overtime or third shift, holiday pay, sick pay, vacation pay, other pay (for bonuses or commissions), non-taxable pay, and tips. The program also has seven deduction fields, including medical, dental, clothing, union, 401(k), auto, and one other deduction field for one-time deductions.

Payroll works on the IBM PC with 256K bytes of RAM (384K bytes of RAM is recommended), MS-DOS 2.0 or higher, and a monochrome, EGA, VGA, or CGA graphics card.

Price: \$95.

Contact: Phoenix Phive Software Corp., 7830 East Gelding Dr., Suite 400, Scottsdale, AZ 85260, (800) 331-1811; in Arizona, (602) 483-0991.

Inquiry 898.

File-Sharing Utility for Incompatible Mac Programs

Open It! is a desktop accessory for Macintosh users that lets you share files between incompatible programs, even if you don't have the application that you used to create the file. Open It! also lets you save files in a common file format, and while you're working in an application, you can access Open It! from the Chooser and merge the file into your working document.

With the program, you can create multiple ScrapBook files and scale graphics images or text on a scale from 1 percent to 1000 percent. The program supports MacPaint, PICT, Glue, and ScrapBook files.

A Print It! utility lets you print any file to disk, and you can access and place the file into any application or document. You can change font styles and sizes to match those of the document to which the information is pasted.

A thumbnail feature of the program also lets you view up to eight pages of a document at a time.

Open It! requires a Macintosh with 512K bytes of RAM.

Price: \$89.95.
Contact: TENpointO, 3885 Bohannon Dr., Menlo Park, CA 94025, (415) 329-0800.
Inquiry 893.

Three-Dimensional Object Font Designer

InterFont is a font editor program for the Commodore Amiga that lets you create fonts that you can use in three-dimensional animation and modeling programs such as Sculpt 3D, VideoScape 3D, Turbo Silver, and Forms in Flight. You can also use the program to make structured clip art for Gold Disk's Professional Page desktop publishing program, according to InterFont's publisher, Syndesis.

Six premade serif and sans serif InterFonts are included with the package. With InterFont, you can also create your own custom shapes in up to 16 colors. The package also includes Syndesis's InterFont Designer, which you can use to trace over any Amiga bit-map font and create InterFonts, which you can enlarge, reduce, and make bold or italic without jagged edges.

InterFont creates lines of three-dimensional text automatically; you enter lines of text, and the package creates the three-dimensional object. The program can also adjust the size, shape, color, and texture of three-dimensional text objects.

The program can also create structured drawings in Aegis Draw format that you can import into Professional Page. When used with Professional Page, you can create custom logos and elaborate text at PostScript resolution; when used with Draw Plus, you can rotate and stretch text.

InterFont also includes InterChange, the company's object-conversion utility.

Price: \$119.95.
Contact: Syndesis, 20 West St., Wilmington, MA 01887, (508) 657-5585.
Inquiry 896.

The Best For Less

\$2.50

Per Disk/10 or more

Easy to use Software for IBM PC's and compatibles

\$3.25

Per Disk/less than 10

ACCOUNTING

- Billpower Plus (2 disks)** — A complete time and billing program for professionals. (hard disk required)
- Financial Consultant 3.0** — An excellent accounting program for home or office.
- Medlin Accounting** — Complete with Gen. Ledger, Accounts Receivable, Accounts Payable & Payroll.
- Small Business Accounting 1.3** — An excellent accounting program designed for small businesses.

BUSINESS/HOME

- Blakbook** — A handy program that will keep track of your addresses and print out nice address books.
- Express Check** — A great program to manage your checking accounts!
- Home Budget & Money Manager** — The title says it all! Easy to use.
- Home Inventory** — Helps you keep track of everything you own. Great for insurance.
- Tickler 4.2** — Great tickler program for appointments, deadlines, reminders and timetables. Can handle up to five people at once.

DATABASE/MAILING LIST MANAGEMENT

- Catalist 3.2 (2 disks)** — Powerful list manager. Generates mail merge files for 15 different word processors. (Hard disk recommended)
- Wampum** — An excellent dBase clone with menus.

EDUCATION

- Amy's First Primer 1.4** — Six different learning programs for children ages 4-8. (Color graphics required)
- Bible-Q 3.3** — Test your bible knowledge with this fun and educational program.
- Funnels and Buckets** — A fun way to teach children basic math skills!
- Play 'n' Learn 2.03** — A collection of six programs for children 18 months to 4 years.
- Typing Teacher** — This disk contains 2 programs designed to improve the speed & accuracy of your typing!
- World 2.93** — The ultimate globe! Learn about cities, countries and continents with this computer version of the globe. (CGA compatible graphics required)

GAMES

- Arcade Games 1*** — Pac-man (3 versions!), Hopper, Space Invaders, Janitor Joe and others.
- Arcade Games 2*** — Q-Bert, Donkey Kong, Mario Bros., Breakout, Beast and others.
- Arcade Games 3*** — Striker, Space War and Quantoids.
- EGA Cunning Football 2.1** — The best football simulation anywhere. EGA or VGA Graphics required.
- EGA Games** — A collection of the best EGA games including EGArroids, Reflex, Aldo, Flees and others. EGA or VGA Graphics required.
- Monopoly*** — A great rendition of the classic game. Great color and sound!
- Nethack** — This classic game is "the ultimate adventure" (hard disk required)
- Pinball** — A collection of several different pinball games.
- Strategy Games*** — Risk, Othello, Chess, Nyet (Tetris clone), and others.
- Star Trek Games** — Three great games on one disk! An arcade game, standard Star Trek game, and a trivia game.

*CGA compatible graphics required.

GRAPHICS

- Flowdraw (2 disks)** — An excellent drawing program with a multitude of features!
- PC-Key-Draw 3.52 (3 disks)** — An exceptionally powerful graphics program.
- PC-Key-Draw Library** — A large collection of ready made graphics for PC-Key-Draw.

- Free Catalog
- Free Shipping on orders of 5 or more disks
- All Orders Shipped Same Day
- Unconditional Money Back Guarantee

OUR LATEST AND GREATEST! RS DISK PICKS

- Banner & Sign Makers** — A collection of programs to make banners or signs for any occasion. Works with any printer.
- Computer/DOS Tutor** — Learn how to use your computer and DOS easily and correctly with this very educational program. A must for anybody trying to learn about computers!
- Ed's Chess** — The best chess game anywhere. (It beat Chessmaster 2000 easily!) Also, this game does NOT require graphics!
- Formgen 3.2** — A very versatile form generator. Make any kind of form for business or home on any printer! (Better than EZ Forms Executive!)
- Graphic-Less Games** — A great collection of games that don't require color or graphics. (They will work on ANY system!!)
- The Lotus Learning System (2 disks)** — Learn Lotus 1-2-3 easily and quickly. (Lotus 1-2-3 is NOT required!)
- PC-File:db (3 disks)** — The latest version of an excellent dBase compatible data base program. Very powerful!
- PC-Write 3.01 (3 disks)** — The latest version of one of the best word processors available. Complete printer support and spelling checker included. Very powerful!
- The WordPerfect 5.0 Learning System (2 disks)** — Great program to help you learn WordPerfect. Easy to use!
- WordPerfect 5.0 Utilities** — A large collection of utilities (including a menu system), and numerous macros for WordPerfect 5.0.

MISCELLANEOUS

- Easy Project 3.0** — A powerful project manager with lots of features.
- Family 3.32** — Trace your family tree with this genealogical program.
- Kwikstat 1.3 (2 disks)** — A complete, easy to use statistics package.
- Planoman 4.0** — Create and play music on your PC! Lots of fun!

PRINTING

- Epson Utilities (2 disks)** — A collection of utilities for Epson and Epson compatible printers.
- HP LaserJet Utilities (2 disks)** — A collection of utilities for the HP LaserJet series of printers and compatibles. Get the most out of your LaserJet, LaserJet II or compatible!
- Mr. Label 3.0** — A very powerful and versatile labeling program.
- On-Side** — Allows you to print anything sideways.

SPREADSHEETS

- Instacalc 2.5** — Memory-resident, Lotus-compatible. ("Editor's Choice" — PC Magazine)
- PC-Calc+ (3 disks)** — A very powerful spreadsheet.
- QubeCalc 3.02** — Lotus-compatible multi-dimensional spreadsheet. ("Editor's Choice" — PC Magazine!)

UTILITIES

- Automenu 4.5** — Latest version of the most popular menuing program of all time!
- Best DOS Utilities** — Essential utilities for DOS. File finders, listers and numerous other handy utilities that will save you time. Very easy to use!
- Help/Pop-Help** — A program that will help you with any DOS command. Very popular and educational.
- Hercules Utilities** — A collection of utilities for Hercules graphics cards. Includes SIMCGA.
- Nawkey 5.0** — The latest version of the best keyboard macro program available. ("Editor's Choice" — PC Magazine!)
- PC-Deskteam 2.01** — A Sidekick-like program with even more features!
- Professional Master Key** — A collection of utilities like Norton's. Recover erased files easily!
- Vaccines and Virus Killers** — A collection of utilities designed to protect your system from viruses! This disk includes Flu-Shot+!

WORD PROCESSING

- Galaxy 2.42** — A very easy to use word processor that has lots of features including a spelling checker.
- PC-Outline 3.34** — An excellent thought outliner! Can also be used as a free-form database. (Resident & Non-Resident versions included!)
- PC-Stylist 1.2** — Analyze your writing style.

- Software for IBM PC's and compatibles
- All programs are the latest version and come with instructions on the disk
- Free catalog with every order or by request
- Unconditional money back guarantee!

Fax: (503) 773-7690

This is just a sample of the over 250 quality programs in our library. If you don't see what you're looking for, give us a call!

For more information call:
(503) 776-5777



Reasonable Solutions
2712 Jacksonville Highway Medford, Oregon 97501

Delivering Excellence in Software, Service & Support

Finally ... a professional menu system in a graphics environment for

Turbo-C, Microsoft-C, Turbo-Pascal:

graphics-MENU™

ONLY \$149 (TP) SOURCE AVAILABLE
works with MetaGraphics MetaWindow

graphics-MENU from Island Systems is a comprehensive utilities package that allows the developer of graphics applications to quickly create a user friendly interface. You can spend more time focussing on the internals of your application.

- Mouse Handling.
- Keyboard support for most menu types.
- Pulldown Menu & Popup messages.
- Underlying graphics automatically saved.
- Button menus in any arrangement.
- Mouse can drag menus & messages to reveal image beneath.

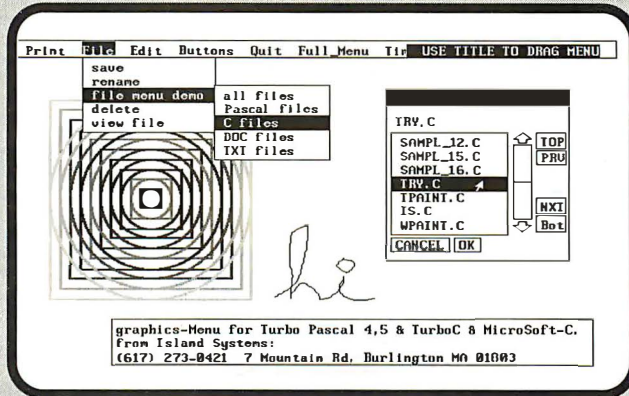

graphics-Menu for Turbo Pascal 4,5 & TurboC & MicroSoft-C.
From Island Systems:
(617) 273-0421 7 Mountain Rd, Burlington MA 01803

We are also including two utility programs: **CurEdit** and **MenuDesigner**. CurEdit is a Cursor icon Editor that enables you to create custom cursor icons and associate them with any mouse button or chord. MenuDesigner is a powerful utility that enables you to create and view complex horizontal & vertical menu structures on-screen and then writes C or Pascal to implement this structure in your application.

Requires: MetaWindow* (MetaGraphics Software Corp). IBM with graphics & mouse (suggested). 30 day money-back guarantee on non-source.

graphics-MENU
TP 4 or 5 \$149
with source . . . \$224
TC or MS-C . . . \$195
with source . . . \$295

MetaWindow*
TP or TC \$95
TP & TC & MS-C \$195
with source . . . \$295

Island Systems
7 Mountain Rd, Burlington MA 01803
CALL
(617) 273-0421

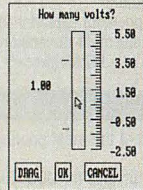

- Vertical list optionally titled.
- Horizontal list with corresponding pull-down menus that may have nested sub-menus to any depth.
- Popup message boxes with or without user prompt.
- Controls & gauges with analog style entry.

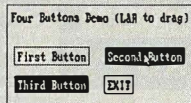

- Limitless hybrids of the above menus for customization.
- Geometric interface functions: point rotation, distance, degrees / radians conversion, true 4-quadrant arctan.
- Analog clock settable by moving its hands with the mouse.

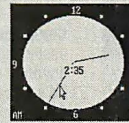
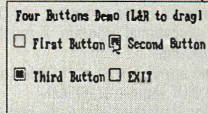

WE ARE THE
LOW PRICED
LAN EXPERTS

MICRO UNIVERSE™ "Lowest Prices in the Universe"

WORDPERFECT
VER. 5.0 218.00
LAN VER. 326.00

(800) 441-4LAN National Order Line • (213) 316-6598 In California

SYSTEM

ACERSTATION	\$ 982
ACER900-2MB	\$1668
ACER910	\$1198
ACER915	\$1161
ACER1100/16MHz	\$2472
AST Model 80	\$1470
AST Model 300	\$2688

LAPTOPS

Toshiba	Call	
Toshiba 1200	\$1409
Zenith	Call	
Mitsubishi	\$2430
MP286L	\$2430

PRINTERS

HP LaserJet	\$1595
Panasonic		
1191i NEW	\$ 232
Laser Partner	\$1496
NEC		
P5200	\$ 509
LC890	\$3160
Toshiba		
P351SX	\$ 970
P321SL	\$ 487

LAN PRODUCTS

Novell Complete 2-Users
Turnkey Network
- 3 XT/10 Computers
- Monitors
- 40 meg Hard Drive
- Novell ELS I O/S
- Arcnet Boards
- Installed & Configured \$2,300

Novell Complete 4-Users
Turnkey Network
- 1 AT/12 Computer
- 3 XT/10 Computers
- Monitors
- 80 meg Hard Drive
- Novell ELS I O/S
- Arcnet Boards
- Installed & Configured \$4,399

Call for Other Novell
Turnkey LAN Packages!

TAPE DRIVE

Archive 150MB	\$825
Mountain 125	Call

SOFTWARE

WordPerfect 5.0	\$218
WordPerfect 5.0 (LAN)	\$326
Lotus 123	\$288
R: Base for DOS	\$488
R: Base for DOS (LAN)	\$662
Pagemaker 3.0	\$486
DBaseIII+	\$415
DBaseIII+ (LAN Pack)	\$620
MicroSoft Word	\$209
MicroSoft Window2.1	\$ 62
PC Excel	\$225
Flight Simulator	\$ 29
Sprint	\$124
WordStar 5.0	\$229

BOARDS

Intel 386/PC	\$745
Intel Above Board	\$380
AST Six Pak Plus	\$274
AST Hot Shot	\$302
ATI EGA Wonder	\$221
Everex EGA	\$162
Paradise VGA+	\$258

MODEMS

Everex 1200B/int	\$ 70
Hayes 1200B	\$250

UPS

DataShield 800W	\$656
-----------------	-------	-------

MISC.

Ribbons Best Price!

Technical Assistance Hours:

Mon-Fri, 8am - 6pm.
Address: 21247 Hawthorne Blvd,
Torrance, CA 90503.
Prices are subject to change without
notice & reflect cash discounts.
We accept most major credit cards,
personal/company checks. Corporate
accounts welcome. On-site Network
installation & training available.
Ask about our RENT-A LAN Program.
Shipping + 3% handling.
In California & International Orders:
(213) 316-6598
Technical Assistance Line:
(213) 316-4008



SHORT TAKES

BYTE editors' hands-on views of new products

SideKick for
Presentation Manager

PhotoMac

Wizard

Discus Rewritable

DOSTALK

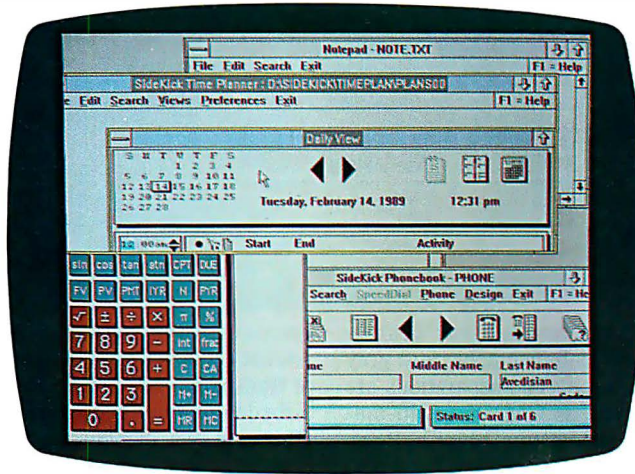

SideKick for PM: More Than Just a Pretty Face

According to some industry pundits, one of the reasons for the apparently slow acceptance of OS/2 is the current lack of useful applications for Presentation Manager, the operating system's graphical user interface. But IBM has come to the rescue by including a free copy of Borland's new **SideKick for Presentation Manager** in every copy of OS/2 1.1. While it's only a hint of the applications that we'll be seeing for PM, it is a fully functional program that lets you do useful chores as soon as you've installed OS/2.

I found SideKick for PM to be both more and less than its better-known cousin, SideKickPlus.

Installation was a snap. Borland's installation utility copied all the files to my hard disk, edited my configuration file, and added a SideKick group to the group window in OS/2's Start Program application. SideKick for PM isn't a TSR program. This is OS/2, without the RAM-cram problem or the danger of applications bumping into one another.

SideKick for PM is a four-part product, with a calcula-

tor, a time planner, a phone book, and a notepad. If you're an experienced SideKick user, it's not hard to see that that's four fewer features than SideKick Plus. SideKick for PM lacks the file manager, clipboard, ASCII table, and outliner of the MS-DOS version. The file manager and clipboard aren't needed, simply because PM has them built in. The ASCII table isn't really necessary either, since PM's main market will be business applications. What about the outliner? A Borland spokesperson told me the company is working on enhanced versions of SideKick for PM.

But it didn't take me long to

find that the four existing applications within SideKick for PM more than make up for what I'd thought was a lack of features. This is a completely new product, and it's a prime example of why I believe PM is destined to become an industry-standard interface. Borland's programmers have fully utilized PM's graphical capabilities. Unlike the character-based MS-DOS version, SideKick for PM is full of buttons, changing cursors, icons, and various fonts and font styles. Taken together, they uniquely integrate SideKick into a useful and easy-to-use program.

It would take much more

THE FACTS

SideKick for Presentation Manager

Free with IBM OS/2
1.1; \$250 when available
separately

Requirements:
80286- or 80386-based
IBM PC, PS/2, or
compatible with OS/2
Standard Edition 1.1
or higher, PM, and
3 megabytes of RAM;

a mouse is recommended,
and a Hayes-compatible
modem is needed for
dialing.

Borland International,
Inc.
1800 Green Hills Rd.
P.O. Box 660001
Scotts Valley, CA
95066
(408) 438-5300
Inquiry 1044.

space than I have to even begin to explore the new capabilities of SideKick for PM. But the phonebook and time planner bear special mention because they use the core database engine from Borland's Paradox. You can swap names, addresses, notes, and appointments to and from the Paradox files. And the time planner is a cutting-edge graphics application. I used a time odometer to select open appointment slots, and *child* windows (windows inside the main application window) let me see three different views of my schedule.

Although nonwindowed OS/2 applications have been available for over a year, SideKick for PM is the first application I've seen that truly takes advantage of PM. It's a tantalizing peek at what will be coming down the line. And since it's free with OS/2 1.1, you couldn't ask for a better deal. IBM and Borland have not announced how long their arrangement will last. SideKick for PM isn't currently available as a stand-alone product, but a Borland spokesperson says it will be available, eventually, for \$250.

—Stan Miastkowski

Industrial- Strength Color Processing

The Macintosh II's color capabilities give it the potential to serve as a color image processing engine. **PhotoMac**, a color-retouching application written by Avalon Development Group and marketed by Data Translation, lets the Mac II achieve this potential. PhotoMac is designed to serve the color press industry: It lets you im-

continued

port 24-bit color scanned images and work with them using a set of retouching and design tools. You then save the modified images in several formats, or you can generate process color-separation files.

PhotoMac works on a Mac II or IIx with 2 megabytes of memory and a standard 8-bit color display. Since even small 24-bit color images can easily be larger than 2 megabytes in size, PhotoMac implements a virtual memory system. That is, only the portion of the image actually displayed consumes memory, while the rest of it is held in a disk file until needed. This lets you easily work on files larger than available memory.

How can you work on 24-bit color images reliably when your screen displays only 256 colors? PhotoMac features an adaptive display, where it uses the 240 colors that best represent the 24-bit data for the part of the image that's on-screen. The other 16 colors are reserved to display PhotoMac's tool palette.

PhotoMac imports a variety of color image formats: PICT, 8- and 24-bit PICT2, 24-bit Tag Image File Format, and TARGA or VISTA files. Once you are finished working with the image, you can save it as 8- or 24-bit PICT2 or 24-bit TIFF files. You can print directly to a Tektronix color printer or a Mirus film recorder.

To do color separations, you specify the screen lines,

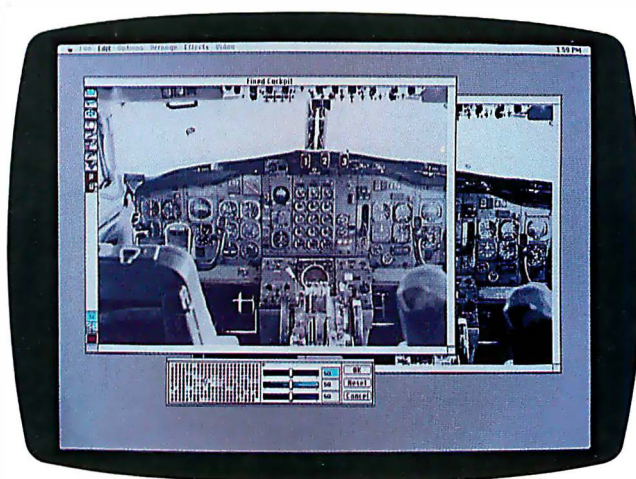

screen angles, gray component enhancement, and gray balance. The separations are saved as CMYK (cyan-magenta-yellow-black) PostScript files, suitable for downloading to a PostScript typesetting system (e.g., the Linotype Linotronic 300). Since the QMS ColorScript 100 laser printer uses color PostScript and not CMYK PostScript, you'll have to import the image file into another application, like Quark XPress, to print it. Since the application is for high-end color prepress, the Apple LaserWriter II printer is not supported.

The tools let you magnify an image (up to 32 times) for precision work or reduce it (to one-eighth its size), and you can rescale it, flip it, or rotate it. You can modify its colors using either RGB or LHS (luminance-hue-saturation)

color-correction systems, or you can retouch it with opaque or transparent colors using an airbrush or paintbrush tool. Of course, you can cut, copy, or paste images. A Copy transparent option lets you paste an image into a white region of an existing image. The image pasted is either scaled to fit the white region or cropped, as determined by a key selection during the paste operation.

I tried PhotoMac 1.0 on a Mac II equipped with 5 megabytes of RAM, a SuperMac 19-inch color monitor, and a Spectrum/24 video board. PhotoMac easily imported PICT2 files from PixelPaint and 24-bit TIFF color images made with Howtek's ScanMaster color scanner and MacScan-It 1.0 software. The tools were intuitive and easy to use. For long operations, a dialog box gives you a countdown in minutes and seconds

with a Cancel button. Image manipulation seemed a bit slow, but because PhotoMac is working with 24-bit data and uses three temporary files to provide an Undo capability, the delays are reasonable.

The manual is one of the best I've seen: For any surprise that turned up while using PhotoMac, I found an explanation in the manual. It includes a tutorial section that explains how to use each tool, with examples. The reference section follows the traditional by-the-Mac-menu layout—that is, selection by selection through each of the menus.

If you want to do special effects for a publication, crank up the reds in a sunset, or take the green out of the faces of the board of directors, PhotoMac is worth a look.

—Tom Thompson

THE FACTS

PhotoMac
\$695

Requirements:
Mac II or IIx with 8-bit color board and monitor, 2 megabytes of RAM, and System 6.0.2/Finder 6.1 or higher.

Data Translation, Inc.
100 Locke Dr.
Marlborough, MA 01752
(617) 481-3700
Inquiry 1045.



The Power of a Wizard

Designed as an electronic organizer, **Wizard** from Sharp Electronics is an 8-ounce pocket computer with 128K bytes of ROM-based software that performs the functions of a calendar, scheduler, memo pad, calculator, personal telephone book, and clock. Additionally, you can get optional "credit card" software packs that contain programs like a

manager, a thesaurus/dictionary, and an eight-language translator.

Wizard comes with its own 32K bytes of RAM and can hold 64K bytes at one time (32K bytes of system memory and 32K bytes with an add-on card). If you buy all the cards, you have a total of 256K bytes; however, you can't use it all at one time.

Wizard lets you store your

continued

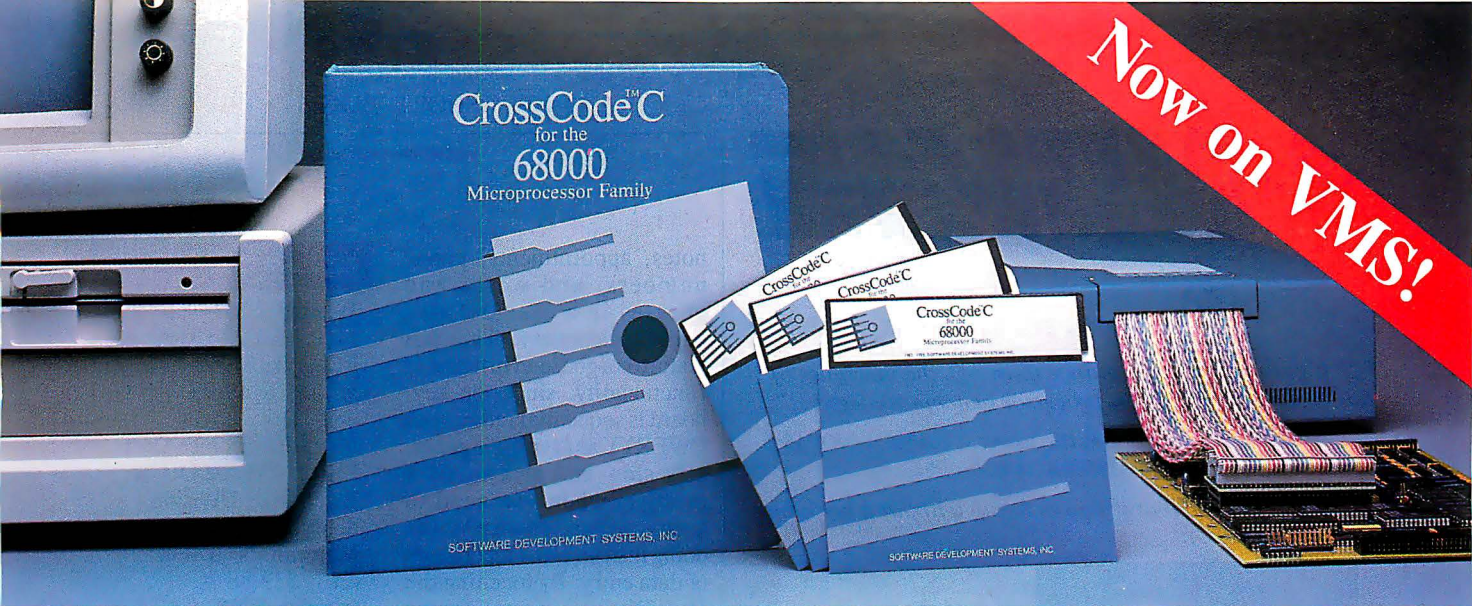

Embedded systems designers have already used CrossCode C in over 357 different applications.

CrossCode C has twelve important features to help you program your 68000-based ROMable applications

It's the one 68000 C compiler that's tailor-made for embedded systems development

CrossCode C is designed specifically to help you write ROMable code for all members of the Motorola 68000 family. It comes with these twelve special features to help you get your code into ROM:

1. **A 100% ROMable Compiler:** CrossCode C splits its output into five memory sections for easy placement into ROM or RAM at link time.
2. **Integrated C and Assembler:** You can write your code in any combination of C and assembly language.
3. **Readable Assembly Language Output:** The compiler generates assembly language code *with your C language source code embedded as comments*, so you can see each statement's compiled output.
4. **Optimized Code:** CrossCode C uses minimum required precision when evaluating expressions. It also "folds" constants at compilation time, converts multiplications to shifts when possible, and eliminates superfluous branches.
5. **Custom Optimization:** You can optimize compiler output for your application because *you* control the sizes of C types, including pointers, *floats*, and all integral types.

6. **Register Optimization:** Ten registers are reserved for your register variables, and there's an option to automatically declare all stack variables as *register*, so you can instantly optimize programs that were written without registers in mind.
7. **C Library Source:** An extensive C library containing over 47 C functions is provided in source form.
8. **No Limitations:** No matter how large your program is, CrossCode C will compile it. There are no limits on the number of symbols in your program, the size of your input file, or the size of a C function.
9. **68020 Support:** If you're using the 68020, CrossCode C will use its extra instructions and addressing modes.
10. **Floating Point Support:** If you're using the 68881, the compiler performs floating point operations through the coprocessor, and floating point register variables are stored in 68881 registers.
11. **Position Independence:** Both position independent code and data can be generated if needed.
12. **ANSI Standards:** CrossCode C tracks the ANSI C standard, so *your code*

will always be standard, too.

There's More

CrossCode C comes with an assembler, a linker, and a tool to help you prepare your object code for transmission to PROM programmers and emulators. And there's another special tool that gives you symbolic debugging support by helping you to prepare symbol tables for virtually all types of emulators.

CrossCode C is available under MS-DOS for just \$1595, and it runs on all IBM PCs and compatibles (640K memory and hard disk are required). Also available under UNIX, XENIX, and VMS.

CALL TODAY for more information:

1-800-448-7733
(ask for extension 2003)

Outside the United States, please dial

PHONE: **1-312-971-8170**
FAX: **1-312-971-8513**

SOFTWARE DEVELOPMENT SYSTEMS, INC.
DEPARTMENT 23
4248 BELLE AIRE LANE
DOWNERS GROVE, ILLINOIS 60515 USA

CrossCode™ is a trademark of SOFTWARE DEVELOPMENT SYSTEMS, INC. MS-DOS® is a registered trademark of Microsoft. UNIX® is a registered trademark of AT&T. XENIX® is a registered trademark of Microsoft.

NEW FROM NOVAS



HONORED BY PC MAGAZINE

"...It gave better performance than ALL the machines of this group on most of the processor benchmark tests..."

"...Working my way down the tower, I found a 'NOVAS SUPER TURBO 286X MOTHERBOARD'..."

"...It's so flexible that it makes living without a big name no chore at all..."



NOVAS
286-14MHz System
Starting at ...\$1195

NOVAS
286-20MHz System
Starting at ...\$1595.

NOVAS
386-25MHz System
Starting at ...\$2295

NOVAS 386SX MOTHERBOARD

• 386 power without the 386 price.

NEVER MORE THAN...\$495

NOVAS 386 MOTHERBOARD Available in 25/20/16MHz versions

- 80386 by Intel, AMI Bios, EMS Support
- Chips & Technologies 386 CHIPset, sockets for 80287 & 80387/Weitek
- Expandable to 16MB (Simm) on board, Interleave/page mode memory 0 wait state
- Shadow RAM, Independent Clock, On board battery, 8 I/O expansion slots
- 1 serial & 1 parallel port on board (optional 2nd serial port).

STARTING AT...\$895

NOVAS 286 NEAT MOTHERBOARD available in 20/16/14MHz versions

- 80286 CMOS by Harris, AMI Bios, EMS 4.0 support
- Chips & Technologies 286 NEAT CHIPset, socket for 80287
- Expandable to 8MB (Simm) on board, Interleave/page mode memory 0 wait state
- Shadow RAM, Independent Clock, On board battery, 8 I/O expansion slots
- 1 serial & 1 parallel port on board (3 more optional serial ports).

STARTING AT...\$345

NOVAS 4000 SUPER VGA 16 BIT CARD

- 100% IBM compatibility at register plus gate level, Shadow RAM
- Expandable to 1MB of display memory, Supports 132 columns for Lotus 1,2,3
- Chips and Technologies 450 VGA product line chips, Analog & Digital Outputs
- 640 x 480 in 256 colors, 800 x 600 in 16 colors, 1024 x 768 in 4 colors
- Backward capability to EGA, CGA, Hercules, and MDA.

NEVER MORE THAN...\$395

NOVAS 386-20MHz w/64k CACHE CONTROLLER

- Increases performance up to 25%

NEVER MORE THAN...\$1495.

"...FULLY LICENSED TO UTILIZE IBM PATENTS..."



Quality Products From
COMPUTRADE CO.

780 MONTAGUE EXPRESSWAY,
SUITE 501, SAN JOSE, CA 95131

OEM, VARS, & DEALERS WELCOME
Corporate & University Discounts

*Service in USA

*VGA, XT, AT & IBM are trademarks of
International Business Machines
*Prices & specs subject to change

U.S. SALES:(408) 435-2662
U.S. FAX: (408) 435-5458

SHORT TAKES

THE FACTS

Wizard, \$299; software packs, \$100 to \$130; PC-Link, \$179; printer, \$169.99

Sharp Electronics Corp.
Personal Home Office
Electronics Division
Sharp Plaza
Mahwah, NJ 07430
(201) 529-8874
Inquiry 1046.

notes, appointments, phone numbers, and words and phrases in a user-defined built-in dictionary. This last feature is a godsend in terms of functionality, since the keyboard is sequential rather than QWERTY and typing is generally slow and awkward—a problem when you need to keep your mind on what you're doing instead of the mechanics of data entry. By touching the User Dic key, you call up the dictionary function and can add or recall often-used sets of words.

In my case, a series of verbs (i.e., call, assign, go to, and meet) and the names of BYTE staff members let me schedule and enter most of the things I need to keep track of with about a half-dozen mostly repetitive keystrokes. I can then set the time for the task and tell the Wizard to ring an alarm to remind me of my next appointment.

The intensity-adjustable LCD shows either eight 16-character lines or four 10-character lines. The space is cramped, and the memo pad and scheduler wrap line endings without proper word breaks or hyphenation. What you wind up with, at first, is wasted time while you go back and put things in a readable order. But again, the user dictionary and a little practice give you a better feel for how much to enter before hitting the Return key.

The Wizard also comes with the ability to import and export data through a serial port. When connected to an IBM PC compatible via Traveling Software's Wizard PC-Link, you can, for example, transfer Borland's SideKick data from the PC into Wizard's scheduler. (SideKick Plus transfers did not work with our beta copy of the program, however, and required BYTE's editor in chief to write a short program to bring the data over.)

Another option, according to Sharp, is the ability to create hard-copy output by connecting the Wizard to Sharp's CE-

50P printer. Further, the company also offers an optional dubbing cable that it says can connect two Wizards and let them share information.

Wizard's calculator function is enhanced by having its own numeric keypad. It has a "paperless printer," or journal-tape function, that helps you keep track of your entries or edit previously input calculations. You can also perform calculations of data stored in the memo pad (e.g., summing price lists). The large-character display in calculator mode is also surprisingly handy.

I could do without the world clock function, but I can see where it might be useful for people who often need to know when would be a good time to put through a call to Seoul or London or Lagos. Another function I'd list as thoughtful on the part of the designers, but only potentially useful to me, is the Wizard's secret mode. Using it, you can password-protect data in your schedules, telephone directory, and memo pad.

In its basic configuration, the Wizard has a lot to recommend it. People like myself who normally have lots of discrete tasks to organize and manage—and who spend a lot of time away from their desks and TSR programs—can always use help in keeping track of events. However, the Wizard's price makes it a question mark for me. It retails for \$299. Additionally, the extra software packs run from about \$100 to \$130 each, the Wizard

continued

How To Get In On Our Frequent Flyer Program



Our new software product will increase the speed of any PC system so dramatically that we're tempted to include a pilot's license (and seat-belt) as standard equipment.

We call it FAST! And from the moment you load it, you'll find that's an understatement. A gross understatement.

Using any benchmark or performance test you choose, FAST!

multiplies the actual processing speed of your system, by four times . . . six times . . . eight times . . . or more, depending on your system and application.

With FAST!, a IBM XT system easily outraces a Compaq Deskpro 386, using a standard data transfer performance benchmark. And without enhancing the hardware in any way.

We've got a winner on our hands.

Speed Enhancement, Without Hardware Upgrades

Our remarkable enhancement is achieved by very simple means. We took a well-known speed-enhancement technique called "disk caching," and improved it. By a mile.

FAST! literally anticipates what data your CPU will be seeking, and reads that data from your drive or floppy into a special RAM buffer (or "cache"), before the CPU asks for it.

Which means that your CPU spends almost no time waiting for disk reads, the most notorious time-

glutton of all. The more disk-intensive your application (database, for example), the more time FAST! will save you.

And since FAST! reduces drive read time drastically, it also reduces wear and tear on your drive, extending its life.

EAST! Blows Away The Competition

Priced at just \$99, FAST! is

competitively priced with other disk-enhancement utility software. Yet it offers vastly superior results—four times the performance of the closest competitors.

And it's hundreds less than hardware upgrade options like faster drives, turbo boards, or entire system upgrades, while again offering superior speed enhancement. And FAST! works with XT, AT, 386 and PS/2 systems, in conventional, extended or expanded RAM.

If you want to give your computer breakneck processing speed, get FAST! To order, call Future Computer Systems at (603) 894-6975. Or, ask your local computer dealer.

For FAX orders: (603) 894-6670



Future Computer Systems
26 Keewaydin Drive, Building H2
Salem, NH 03079
(603) 894-6975

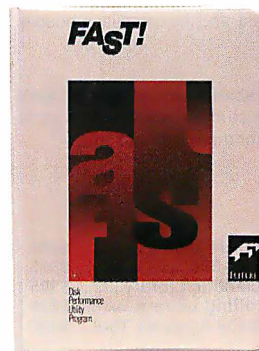

DATA TRANSFER RATES
IN KILOBYTES PER SECOND

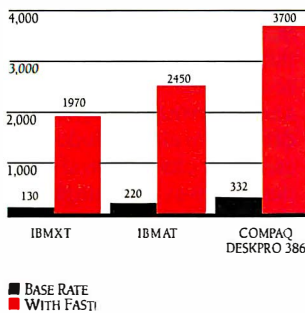

XT, AT and PS/2 are trademarks of International Business Machines Corporation. Compaq DESKPRO 386 is a trademark of Compaq Computer Corporation. FAST! is a trademark of Future Computer Systems.

PROTECT INTELLIGENCE WITH INTELLIGENCE



See us at
COMDEX-
SPRING '89
BOOTH
#8474

SOFTWARE PROTECTION KEYS BY PROTECH

PROTECH KEYS:

- are totally transparent to the end user
- allow unlimited back up copies
- free up disk drives
- do not interfere with peripheral operations
- are easy to install
- protect software developers' revenues
- assembler based routines (not drivers)
- encrypted routines
- physically unique hardware KEYS
- sophisticated software installation advice
- provide the highest level of protection available

THE MEMORY KEY

The MEMORY KEY is a programmable software protection device. Each byte of memory can be addressed in groups or individually. Possible applications for the MEMORY KEY include:

- modular package control
- serialization
- customization
- access control to PCs
- demo control
- software leasing
- updating modules in the field
- any "counter" operation

For a demonstration package or additional information, please write or call:

1-800-843-0413

PROTECH MARKETING, INC.
4905 Pine Cone Drive • Building 10
Durham, North Carolina 27707
(919) 490-4970 FAX (919) 490-4974

WE HAVE THE KEY TO SOFTWARE COPY PROTECTION

PC-Link costs \$179, and the printer goes for \$169.99. Once you start adding on, the price adds up.

I've used Wizard enough to know that I could eventually rely on it as easily and as naturally as a pocket notepad—and because of its automatic alarm capabilities, it's at least one cut above pencil-and-paper-based organizers.

On the other hand, the price is a barrier right now. I'm not sure how much I'd be willing to pay just to have my notepad kick me awake for a meeting or to go harass some poor editor about a deadline. Of course, discounting is a fact of life. I'm making a note in my Day-Timer to check it out again in a few months.

—Glenn Hartwig



Discus Rewritable: The Latest in Storage Technology

One of the big surprises when Steve Jobs introduced the NeXT computer last October was its erasable, rewritable optical disk drive. Now, you don't even have to wait for a NeXT computer to get your hands on the latest in storage technology: A new optical disk drive from Advanced Graphic Applications (AGA) connects to an IBM PC AT and offers 650 megabytes of storage at a cost per byte comparable to hard disk drives.

Rewritable optical technology is the successor to WORM (write once, read many times) technology, which lets you permanently archive data on shiny, durable laser disks similar to audio CDs. The Discus Rewritable drive offers the benefits of a WORM drive—huge capacity, long-term stability of data, and portability—with the added flexibility

of conventional magnetic media. And it's so fast that in tests with workaday software packages like databases and word processors, it performed nearly as well as (and in some cases better than) my trusty old hard disk drive.

The Discus Rewritable is available either in an internal, full-height configuration or as an external unit with its own power supply and fan. Both versions communicate via a SCSI port designed by AGA that is included with the product. Cables, documentation, and software utilities and drivers are also included. You can daisy chain up to six additional drives to a single controller through an external SCSI port on the back of the external model.

I tested an external model on several different com-

continued

SVS FORTRAN-386 The Real World Solution

- Complete 386 Software Package
- Runs in 32-bit Protected Mode
- Accesses all Available Memory
- Supports VAX and IBM Extensions
- Supports the Intel 287/387 and Weitek Chips
- Applications run four times faster than those from most compilers
- Compiles at high speed

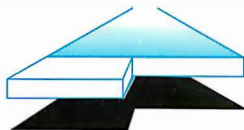

Package Includes:

- SVS FORTRAN Compiler
- LINK-REX Linker
- 100% Royalty Free License on distributed software
- Librarian
- DOS Extender
- DOS Support Library
- Debugger
- Technical Support

"The LOADS module in DOE-2 is about 14,000 lines of code. I used SVS FORTRAN-386 since it was the only compiler that would swallow the source code (VAX extensions)." - *Programmer's Journal*

"The SVS compiling and linking is extremely fast, and the compiler produces nicely compact code." - *Mirco/Systems*

Software Conversion Services are also available for converting FORTRAN mainframe source code to the 80386. This service includes conversion, code optimization, user I/O, and more. Call SAIC for more information.



PRICES:

SVS FORTRAN-386.....	\$895
SVS PASCAL-386.....	\$895
Scitech Scientific Library.....	\$325
Scitech Plotting Library.....	\$325
Maintainability Analysis Tool..	\$895

For more information call: 1-800-346-5159 In CA Call: (415) 960-5931

Not only does Telebit make the world's fastest modems, we also endorse your checks.

If you're looking for a high-speed, dial-up modem that endorses industry standards and more, check out the Telebit® T2500.

As well as transmitting data error-free at a lightning-fast 19,200 bps with Telebit's PEP™ modulation, the T2500 also adds V.32 to its modulation list. That means you can automatically use the CCITT V.32 standard for synchronous or asynchronous connections.

So, for large-volume or interactive transmissions, you won't find a better modem than the Telebit T2500. It supports all major modem standards, and is ideal for connecting micros to LANs or mainframes. Plus it easily handles international transmissions. And speaks fluently with more dial-up modems than any other.

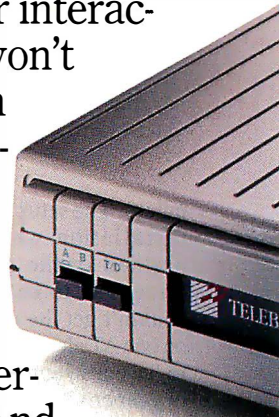

In addition to the industry's highest data rate, Telebit's multicarrier PEP technology makes hang-ups and bad line problems a thing of the past.

To find out more about the world's fastest modem, call 1-800-TELEBIT today. Or write us at 1345 Shorebird Way, Mountain View, CA 94043-1329. Phone: (415) 969-3800.

Learn why no one gets the message through like Telebit.



© 1989 Telebit is a registered trademark and PEP is a trademark of Telebit Corp. MNP is a registered trademark of Microcom, Inc. Other product names are trademarks of their respective holders.



THE FACTS

Discus Rewritable.
\$4995 (internal),
\$5495 (external)

Requirements:
IBM PC AT or
compatible (no minimum
RAM requirement)
with DOS 3.0 or higher;
SCSI controllers also
available for IBM PC XT
and Micro Channel.

Advanced Graphic
Applications, Inc.
90 Fifth Ave.
New York, NY 10011
(212) 337-4200
Inquiry 1047.

puters. The setup and software installation were well explained in the manual and turned out to be very easy. I couldn't get the drive to work on one AT clone that turned out to have a strange direct-memory-access controller (the

SCSI port uses a DMA channel), but this problem disappeared on a more fully IBM-compatible system.

The drive uses 5 1/4-inch magneto-optical disks supplied by 3M. One disk is included with the drive, and ad-

ditional disks cost \$250. Each disk holds 650 megabytes of data, or 325 megabytes per side, but you have to manually turn over the disk to access the other side.

As with conventional hard disks, you have to partition the disk, but this is simplified by a software routine supplied by AGA. (Disks are shipped formatted on side A, but you must perform a low-level format on side B that takes about 25 minutes.) Each side can be configured as a single giant partition. To set up partitions larger than 32 megabytes under DOS 3.0, however, you have to run a DOS patch provided by AGA. (This will not be necessary in the DOS 4.0 version, which was not yet available.)

On the downside, I found

the external unit heavy and bulky, and its fan was very noisy. I was also annoyed by a few minor details, all of which I could live with: The Discus Rewritable always has to be turned on after the computer, disks have to be removed with the drive on, and they must be removed to lock the heads for transport. But overall, Discus Rewritable seemed to be a solid, reliable, and well-designed product.

Perhaps my greatest pleasure was the sensation of space I felt every time I saw the DOS DIR listing that said "322,830,336 bytes free." It must have felt the same way to be a pioneer in the Old West and come upon an undiscovered territory.

—Andy Reinhardt

Talk to Me, DOS, Talk to Me

DOSTALK from SAK Technologies is a natural-language interface for MS-DOS-based computers. Instead of having to type in such cryptic commands as COPY C:\ARTICLES*.DOC C:\BACKUP, you simply enter the phrase "copy all the files in the Articles directory that have the extension Doc to the Backup directory" (capitalizing *only* the names of files and directories.) DOSTALK then translates that into the correct DOS commands and executes them.

Installing DOSTALK is

THE FACTS

DOSTALK
\$129.95

Requirements:
IBM PC with 300K bytes
of RAM and DOS 2.1
or higher.

SAK Technologies, Inc.
1600 North Oak St.
Suite 931 W
Arlington, VA 22209
(703) 522-6425
Inquiry 1048.

fairly easy; an automatic installation program creates a subdirectory called DOSPEAK and copies several files from your DOS directory into it. The next time you reboot, DOSTALK will be available any time you press F2.

DOSTALK does all the easy things: list filenames, copy files, and so on. I wondered, though, how it would do with fancier commands. Plain old DOS lets you invoke "switches" at the end of many commands to provide added features.

When I said "show Article.doc one screen at a time," DOSTALK correctly invoked the MORE option of TYPE. "All right," I thought. "I'm impressed."

Unfortunately, DOSTALK then managed to mess up what I consider a fairly easy request: When I typed "show all the files that end in Doc," DOSTALK replied "Subdirectory Doc NOT FOUND." Not until I asked it to show the files that end with a Doc extension did I get what I wanted. This is supposed to be plain English?

There were other times

when DOSTALK would get confused and go off on a long search for something I hadn't intended. For example, if you want to use a plain old DOS command, you have to type a \$ first. I once typed DIR T*.* without the \$, and DOSTALK asked "What should I do with the T*.* directory?" I replied "show them," and DOSTALK answered "Files T*.* NOT FOUND," even though there *were* files in that subdirectory that began with T. DOSTALK then proceeded to go looking for *all* the files on my hard disk that began with the letter T—a long list, and one that I didn't need to see. Unfortunately, DOSTALK doesn't let you interrupt once it has started on a long trek. (Sometimes, however, you can hit Control-C to abort an action.)

Yet another time, I asked DOSTALK to "print the names of the files," to which it replied "Name of list device [PRN]:." How many novices are going to know the correct response, LPT1? It then proceeded to print the *full text* of the files, rather than the directory list that I wanted. Urk! Where's the power switch on

that printer?

DOSTALK does have some nice features, like the ability to undo the last command. And if you ask it to erase an entire subdirectory, it will ask you if you want to erase the files in it first. DOS just tells you that it's an "Invalid path, not a directory, or directory not empty."

One obvious omission from DOSTALK, though, is an on-line help facility. Any program (especially one that will be used by novices) that doesn't respond to a help cry with *some* kind of response deserves to go back to the shop.

Who needs DOSTALK? Certainly not someone who has been using a DOS machine for any length of time. Once you've learned the basic syntax, you can probably make DOS do what you want—faster, easier, and more flexibly than with DOSTALK. People with absolutely no DOS experience might find DOSTALK useful, but they'll probably need help from a DOS user to set it up. Even beginners will probably feel constrained by DOSTALK after a while.

—Ken Sheldon ■

WHETHER REPORT.

Whether you're a software developer writing new applications for the IBM or Mac, or a PC user securing proprietary data files, software and data protection has never had a brighter silver lining. For a number of very good reasons.

Beginning with the 'whether-expert' Rainbow Technologies. And ending with its Software Sentinel family of hardware keys. Starring five models that fit virtually any software program or data file you need to protect.

There's the best-selling SentinelPro for the IBM PC/XT/AT, PS/2 and compatibles, and even the Atari ST. Known worldwide for its virtually unbreakable security. And its ASIC technology. And its invisible operation. A close relation, the Sentinel-C stands at-the-ready for custom configurations and multiple software packages.

In the Apple market, security-minded Mac software developers turn to Eve. For completely transparent operation and world-class security of the protected software. Just by plugging Eve into the Mac ADB connector.

PC users wanting a low cost, user-friendly solution to the problem of securing sensitive data can call on the DataSentry. Using a proprietary Rainbow algorithm or DES, the DataSentry encrypts data files on individual PCs, protects modem transmissions and secures data on local area networks.

Rainbow's latest protection strategy is the SentinelShell—that lets users place a 'shell' around existing, off-the-shelf programs. Because access can be limited to those issued a key, libraries, universities and corporations can very simply guard their software investments.

Whatever your whether, Rainbow Technologies has the software and data protection products that make the difference. For more information, call 714-261-0228 in the U.S., or contact Rainbow Technologies Ltd. in the United Kingdom for the distributor nearest you. Whethercasters are standing by.

SentinelPro™

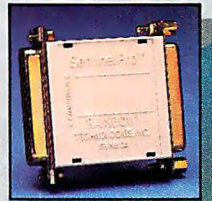

- Runs under DOS, OS/2 and Xenix • Algorithm technique (Never a fixed response) • External parallel port installation
- Minimal implementation effort • Higher level language interfaces included
- 100 times faster than fixed-response devices (1 ms)
- ASIC design for reliability

Sentinel-C™



- Protects multiple packages with one device • 126 bytes of non-volatile memory programmed before shipment of the software • Rainbow supplies a unique adapter for programming the unit
- Higher level language interfaces included • Runs under DOS, OS/2 and Xenix
- External parallel port installation

Eve™



- For the Macintosh SE and II • Complies with Apple Desktop Bus Interface requirements • Rainbow-assigned developer passwords to prevent tampering by other developers or sophisticated "hackers"
- 7 locks per key, usable individually or in combination, on one or up to seven applications

DataSentry™

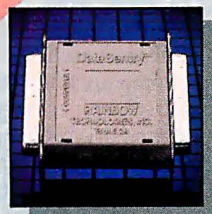

- Completely user-installable
- Pocket-sized external device • Menu-driven, user-friendly interface • Single- or multi-user security system
- Audit trail, log-on identifiers and automatic encryption/decryption of entire directories • Secures data transmitted by modems
- Prevents recovery of data by utility programs

SentinelShell™

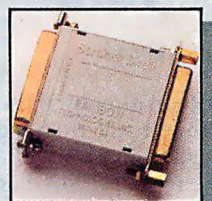

- Runs under DOS on IBM PCs and compatibles
- Protects without requiring access to the source code
- Completely transparent to the end user • User-friendly software
- Pocket-size key attaches quickly to any standard PC parallel port
- ASIC design for reliability

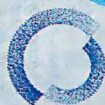

RAINBOW TECHNOLOGIES

18011-A Mitchell South, Irvine, CA 92714 • (714) 261-0228 • TELEX: 386078 • FAX: (714) 261-0260
Rainbow Technologies, Ltd., Shirley Lodge, 470 London Rd., Slough, Berkshire, SL3 8QY, U.K., Tel: 0753-41512, Fax: 0753-43610

© 1989 Rainbow Technologies. All product names are trademarks of their respective manufacturers.

Circle 313 on Reader Service Card (DEALERS: 314)

32.5 MHz and Climbing

Rated for 33 MHz
and running at 32.5 MHz,
SIA's 386/32 defines
a new speed plateau

Just over a year ago, 20-MHz 80386 systems left us slack-jawed by the sheer power they delivered. A few months later, a clutch of 25-MHz machines provoked a similar reaction. Now, Systems Integration Associates (SIA) has begun shipping its 386/32, the first PC-compatible machine running on a 32.5-MHz clock—a unit that sets a new standard in microprocessor speed.

Chicago-based SIA managed to scoop the Compaqs and Advanced Logic Research machines by putting together a system board designed for 32 MHz with an Intel chip rated for 25 MHz and some additional hardware to keep things running smoothly. At the heart of the system is a high-speed cached memory design and cooling equipment dedicated to keeping chips close to their rated temperature while running above their rated clock speed.

Integration by Parts

While not a from-the-ground-up manufacturer like some of the bigger names in the industry, SIA has assembled an impressive machine by combining a good collection of subassemblies and adding a few touches of its own to cover up the seams. The basic system, which lists for \$13,100, includes the system board stuffed with 4 megabytes of RAM, a case, a 200-watt power supply, a hard disk drive controller, a serial/parallel

card, and a keyboard. The fully loaded evaluation unit weighed 70 pounds. It was mounted in an optional tower case that stands a good 6 inches taller than a PS/2 Model 80. With hard disk drive, tape drive, and coprocessor, the unit lists for \$19,830.

Chief among these integrated subsystems is a motherboard built to handle 32.5-MHz operation. The 30 percent increase in frequency from the last generation means that physical problems, like stray capacitance and transmission line effects, become more acute, requiring careful board layout. Also critical to a good design is a memory subsystem that won't bottleneck the processor.

To keep up with 32.5-MHz operation, a conventional design would require 30-nanosecond static RAM. SIA gets around the prohibitively expensive solution of implementing the entire main memory in 30-ns SRAM by using a 64K-byte, direct-mapped, 20-ns SRAM cache. SIA claims zero-wait-state operation and an 81 percent hit rate for the write-through cache, operated by a discrete logic controller. In a direct-mapped design, each memory access involves comparing a *tag* (which specifies blocks within the cache) with part of the requested address. The system uses faster 15-ns SRAM to store the frequently used cache tags, further enhancing performance. Up to 16 megabytes of main memory can be cached; accessing any memory installed beyond this limit will slow the system considerably.

The main memory is made up of relatively fast 70-ns DRAMs. Four banks for dual in-line package memory are available on the motherboard, along with 4 single in-line memory module slots. DIP sockets are compatible with both 256K-byte and the larger 1-megabyte DRAM chips. SIA claims that both SIMM and DIP sockets will be compatible with the not-yet-released 4-megabyte versions of each package. With 1-megabyte parts, you can get up to 8 megabytes

on the motherboard; when 4-megabyte components are released, the board will take not 32, but 16 megabytes—a system board limit imposed by the BIOS. An additional 24 megabytes can be added via the single 32-bit I/O slot, but, in any case, the upper addressable limit is 32 megabytes.

The processor itself is a 25-MHz Intel 80386 that has been tested for operation at 33 MHz by SIA. Both the 25-MHz Intel 80387 and Weitek 3167 coprocessors are supported.

The greatest difficulty in running a device beyond its listed rating is chip heating, as heat generation increases with clock speed. To keep things cool, SIA has mounted a cross-flow blower just above the processor and coprocessor socket, which, the company claims, keeps the chip case very close to ambient temperature. The CPU is also mounted slightly elevated (3/32 inch) from the socket, allowing air to flow underneath as well. I checked temperature differences with a digital thermometer. The chip case got as high as 11°F above ambient (i.e., 86 degrees) but never showed any adverse reaction to the heat.

SIA plans to offer early buyers of the 386/32 an upgrade to the 33-MHz CPU once Intel makes it available. The swap will cost those users a maximum of \$500 with the return of the 25-MHz chip. SIA had not determined the exact upgrade charge at this writing.

Except for the high-speed modifications, the board looks like any number of 25-MHz 80386 motherboards currently available (see photo 1). It also interfaces just as easily, because the one 8-bit and six 16-bit I/O slots can run at a compatible bus speed of 8 MHz. The BIOS, designed by American Megatrends International (AMI), includes ROM-based setup and diagnostics and allows video BIOS relocation. I found that video BIOS relocation meant a threefold performance increase in some graphics functions, but it

continued



Table 1: Benchmark results of a comparison between the SIA 386/32 and the ALR FlexCache 25386. For indexes only, higher numbers reflect better performance.

CPU	SIA	ALR	DISK I/O	SIA	ALR	VIDEO	SIA	ALR
Matrix	2.10	2.60	Hard Seek²			Text		
String Move			Outer track	3.33	1.64	Text average	3.21	4.60
Byte-wide	15.54	16.20	Inner track	3.31	3.33	Graphics		
Word-wide:			Half platter	6.65	6.67	Graphics average	1.96	1.94
Odd-bnd.	17.78	21.97	Full platter	9.10	8.35			
Even-bnd.	7.78	8.13	Average	5.60	5.00	<input type="checkbox"/> Index:	3.06	2.57
Doubleword-wide:			DOS Seek			Application Indexes		
Odd-bnd.	13.14	15.93	1-sector	10.23	6.93	Word processing	4.41	4.41
Even-bnd.	3.87	4.03	32-sector	18.77	15.35	Spreadsheet	4.07	4.13
Sieve	11.02	14.02	File I/O³			Database	2.02	2.83
Sort	8.26	10.50	Seek	0.04	0.06	Scientific/		
<input type="checkbox"/> Index:	5.99	5.07	Read	0.85	0.49	Engineering	6.24	5.80
FLOATING-POINT			Write	0.76	0.78	Compiler	3.94	4.08
Math	3.79	4.90	1-megabyte			<input type="checkbox"/> Index:	20.67	21.24
Error ¹	0.00E+00	0.00E+00	Write	2.89	2.91			
Sine(x)	1.23	1.54	Read	4.28	2.92			
Error	2.00E-09	2.00E-09	<input type="checkbox"/> Index:	2.36	2.74			
e^x	1.20	1.81						
Error	1.00E-09	1.00E-09						
<input type="checkbox"/> Index:	14.20	10.55						

All times are in seconds. Figures were generated using the 8088/8086 and 80386 versions (1.1) of Small-C.

¹ The errors for Floating Point indicate the difference between expected and actual values, correct to 10 digits or rounded to 2 digits.

² Times reported by the Hard Seek and DOS Seek are for multiple seek operations (number of seeks performed currently set to 100).

³ Read and write times for File I/O are in seconds per 64K bytes.

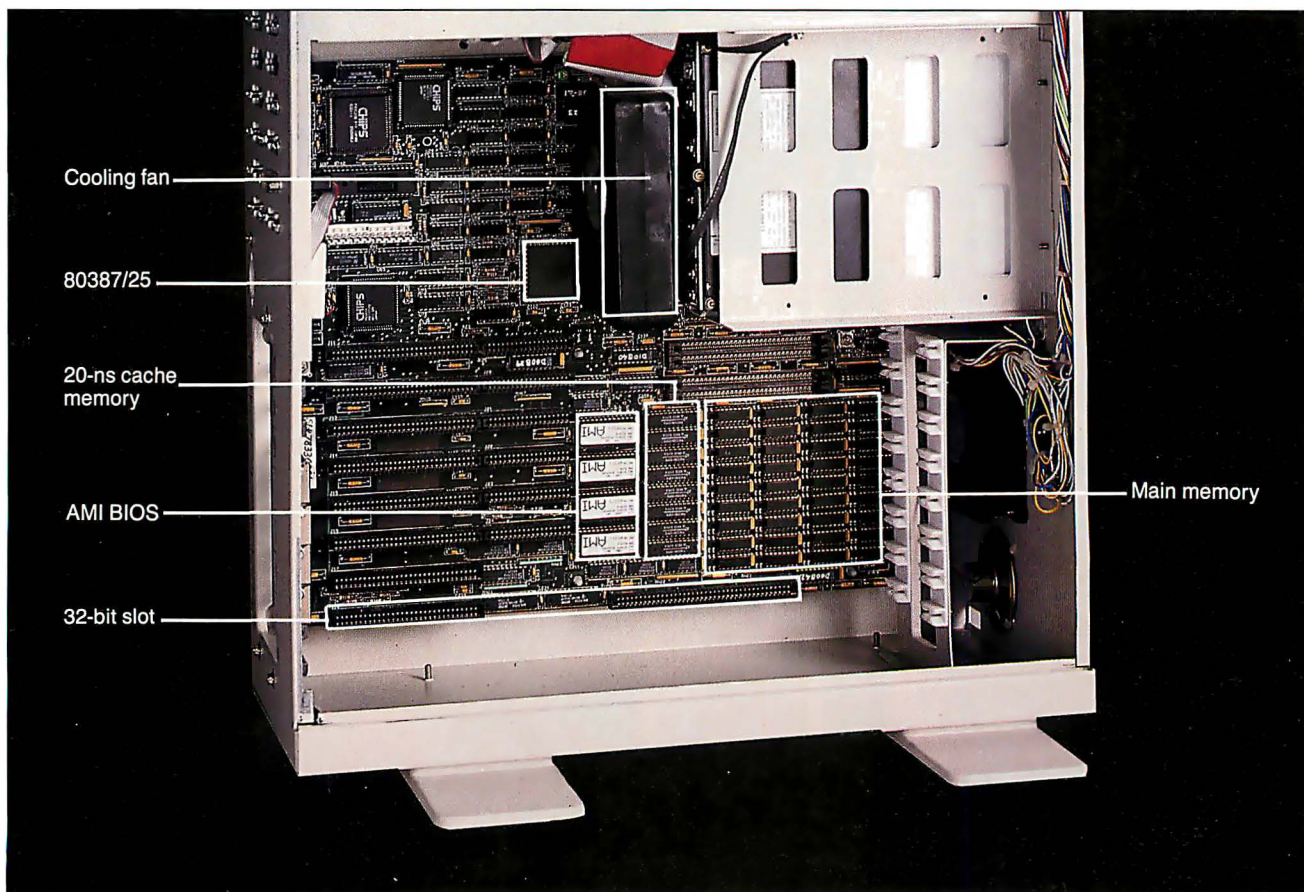

Photo 1: The SIA 386/32's interior. The most striking departure from conventional systems is the presence of a dedicated CPU fan (CPU is mounted behind fan).

will cost you 256K bytes in RAM above 640K bytes. The BIOS also allows you to toggle between 32.5- and 8-MHz CPU speed and to enable or disable caching with a hot-key sequence.

The disk subsystem, of course, often causes a bottleneck when combined with a high-performance CPU. SIA went a long way toward solving that problem by providing an ESDI controller as part of the standard system. The controller, an Adaptec ACB-2322, supports two hard disk drives and two floppy disk drives. With a data transfer rate of 900K bytes per second, the controller is well matched with the rest of the system. The unit I looked at included a very quick (16.5-millisecond rated access) 150-megabyte Control Data hard disk drive (which is not part of the standard configuration), adding to the system's impressive specs.

The unit also included a 150-megabyte tape backup system, two floppy disk drives, an 8-bit VGA controller, and an analog monitor. The monitor display is crisp, and the keyboard has an excellent feel. Unfortunately, the system unit interferes with the monitor when they are close together, and the standard monitor cable is quite short. The unit is FCC Class A-approved for business but not home use.

Proof in Performance

I test-drove the SIA 386/32 with BYTE's standard benchmark suite. Not surprisingly, the system set new performance records in most of the tests (see table 1). That word *most* is of critical importance; what's interesting is that this 32-MHz system could not quite out-distance the entire the 25-MHz pack. For the purpose of comparison, table 1 lists the SIA 386/32's benchmark numbers next to those for ALR's 25-MHz FlexCache.

The low-level CPU and FPU benchmarks reveal the kind of performance you'd expect—the SIA is consistently faster than the FlexCache. While the times vary slightly from test to test, the SIA's overall CPU index shows a performance increase over the FlexCache of about 18 percent. FPU performance increase is about 35 percent. These numbers are impressive indeed, considering ALR's 386/25 was the fastest unit we'd tested until now, but the relative CPU performance doesn't quite measure up to the 30 percent difference in CPU clock speed.

Disk speed was good, and the Adaptec/Control Data ESDI combination certainly did not result in any noticeable waits. Unfortunately, the disk subsystem

Processor
*speed is not
an end-all measure
of performance.*

was outperformed by ALR's similar ESDI unit. While write operations and seek times are roughly equivalent, the SIA's disk-read scores are poor.

I tested the 386/32 using the video shadow-RAM feature, which made graphics operations fly. ALR's 16-bit VGA adapter had outstanding graphics speed, which proved unreachable for the SIA 8-bit card, but the SIA came out with a higher overall score.

These minor shortcomings in disk and graphics performance significantly hampered the 386/32's application performance, and the overall application index is actually slightly lower than the 25-MHz FlexCache's. Disk-intensive database operations were disappointingly slow.

High speed can mean software incompatibility if floppy disk drives run too fast, but that wasn't the case with the 386/32. The system had no problems with copy-protected Lotus 1-2-3, an application that usually weeds out systems with incompatible floppy disk speeds.

Final Thoughts

The SIA 386/32 promises excellent processing speed, and its high clock rate and cached memory design deliver. With the aid of the interior blower, the 25-MHz-rated chips run without difficulty. When armed with a high-speed coprocessor, there probably isn't a faster PC-compatible number cruncher available today.

Processor speed is not, however, an end-all measure of performance, and number crunching is not a computer's only function. Some of the peripheral components could not keep up with the CPU, and application performance suffered. These units can be replaced and indeed are not even part of the basic system. Replacements are unlikely to save money—this top-shelf system requires top-shelf parts; it's hard to imagine a 386/32 that fully exploits its system board power for under \$17,000. ■

Steve Apiki is a testing editor for the BYTE Lab. He can be reached on BIX as "apiki."

1	Exxon
2	General Motors
3	Mobil
4	Ford Motor
5	IBM
6	Texaco
7	E.I. du Pont
8	Standard Oil (Ind.)
9	Standard Oil of Cal.
10	General Electric
11	Gulf Oil
12	Atlantic Richfield
13	Shell Oil
14	Occidental Petroleum
15	U.S. Steel
16	Phillips Petroleum
17	Sun

**27
million
Americans
can't read.
And guess
who pays
the price.**

Every year, functional illiteracy costs American business billions.

But your company can fight back...by joining your local community's fight against illiteracy. Call the Coalition for Literacy at toll-free **1-800-228-8813** and find out how.

You may find it's the greatest cost-saving measure your company has ever taken.

**A literate
America is a
good investment.**

Ad Council  Coalition for Literacy

The Only Character Recognition System



That Outperforms Ours

Nature's character recognition system can be trained to read any language. Flagstaff Engineering's **SPOT OCR Text Reader** is also trainable. It has read text printed in thousands of typefaces in over 130 different languages!

The SPOT OCR Text Reader works just like a typist who reads a page, then uses a keyboard to transfer the information on the page into a computer file—except SPOT uses a scanner for eyes and outputs the text directly into standard text files. SPOT is also faster. It can read up to 35 characters per second on a 16MHz AT, and up to 65 characters per second on a 25MHz machine (that's 780 words per minute). SPOT supports most major makes of scanners.

Using sophisticated statistical techniques, SPOT recognizes characters like the brain does: by examining their shape and context. Like nature's original, SPOT is very flexible. It can glance over an entire page or zoom in on a few lines of text. SPOT can read newspapers,

magazines, books, manuals, invoices, contracts, government documents, columns, tables . . . just about any printed text. And SPOT keeps getting better. The **new Version 3.0** is faster, more accurate, easier to use, and better documented than its predecessors.

Since 1982, Flagstaff Engineering has provided visionary data conversion solutions for thousands of companies worldwide. SPOT is already increasing productivity and making life easier for many publishers and researchers, accountants and telemarketers, medical and legal offices, archival and transcription services.

Wouldn't *your* business benefit from fast, accurate, and low-cost OCR software? Give us a call and let our application specialists explain how you can save time and money with SPOT, *the* OCR text-entry solution.

Spring COMDEX Booth 145



Join Flagstaff Engineering's
BIX conference: flageng

Circle 96 on Reader Service Card for
S.P.O.T. 3.0 Version
97 for 9 Track Tape
98 for Disk Conversion Systems Up-Date
99 for DEALERS only

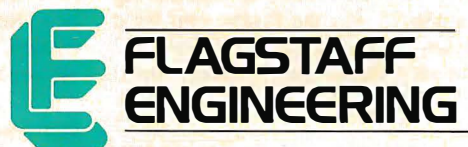

Helping People Read a World of Information

1120 Kaibab Lane • Flagstaff, AZ 86001
602-779-3341 • FAX 602-779-5998



Jerry explores the highways and byways of programming choices

It won't be finished here, but I'm beginning this column on the island of Molokai. To be exact, I'm at the Kaluakoi Resort, which is on the northwest corner of the island. Like most people, the only thing I knew about Molokai—which is written locally Moloka'i and pronounced Molokay-aye—is that there is a leper colony here, but you're supposed to say Hansen's disease.

Actually, while there is a hospital community on the Kaluapapa Peninsula and some of the former residents live there, the isolation of Hansen's disease patients—begun here by decree of King Kamehameha V in 1865—hasn't been the law for years, since Hansen's disease is now completely controllable.

I'm here for the conference on Grand Challenges to Computational Science, where I'll be the dinner speaker. I also expect to learn a lot about the future of supercomputing. More on that later.

Languages Reconsidered

Before I left, I did a lot of work on Mrs. Pournelle's Reading Program. This was originally begun by Bruce Tonkin in Microsoft BASICA. Tonkin writes many of his programs for TNT Software in BASICA and sells some amazing products, complete with source code, at quite reasonable prices.

Then about a year ago, I began converting the Reading Program into Compiled BASIC. I tried Borland's Turbo Basic, then I tried Microsoft QuickBASIC 3.0, and I went from there to QuickBASIC 4.0.

I don't get to do a lot of programming. This project was certainly the biggest

one I worked on last year. Since I use real projects to learn, get used to, and evaluate other programs and products, I was more than once tempted to abandon BASIC and work with another—and presumably more modern—language.

There were a number of contenders. I'm still fond of Modula-2. Logitech's Modula-2 system has an excellent debugger and a good working environment for PCompatibles. Workman & Associates has FTL Modula-2 for both PCompatibles and the Atari ST, so I'd have at least that much portability for the code. There are many good libraries of program modules that go a long way toward overcoming Modula-2's rather primitive I/O and string-handling capabilities.

Another possibility would be Borland's Turbo Pascal 5.0; certainly that would be hard to beat for sheer popularity, and the new Borland Turbo Debugger is neat and fairly easy to learn. One—perhaps the main—reason Modula-2 hasn't caught on as fast as I thought it would is that Turbo Pascal 5.0 incorporates many of Modula-2's major features while remaining easy to learn. It also compiles like lightning.

Finally, Turbo Pascal has become popular enough that literally dozens of programmers have developed packages of thoroughly tested and debugged sub-routines you can incorporate into your programs; it's not necessary to invent the wheel each time. For example, Robert Jourdain's *Turbo Pascal Express* (Brady Computer Books, 1988) comes with a whole slew of useful assembly language routines. You can also get the Peabody on-line help utility to make learning and using Turbo Pascal even easier.

Something Completely Different...

Of course, I already more or less know Pascal, Modula-2, and QuickBASIC. For a while there, I toyed with the idea of using this project as an opportunity to learn something entirely new.

One choice would be Ada. I keep hear-

ing contradictory tales about that language. One group says it was designed by a committee and shows it: there are too many features, so that the resulting language is too big and too slow and just not useful for practical programming.

A second group says that's all nonsense: Ada is a splendid language, no more complex than many others, especially if you don't use some of the special features. They say the RR Software Ada Compiler for PCompatibles is plenty good enough for production work, and it produces code that's competitive in speed and size with any other language's output. After all, RR's Compiler is written in Ada and compiles itself nicely.

It would be instructive to find out which group is right.

There are certainly differences in philosophy between Ada and Modula-2. For one thing, Ada incorporates exception handling, something that's anathema to Modula-2's designer Niklaus Wirth ("anyone who needs exception handling just doesn't know how to program"). The designers of Ada, on the other hand, wanted a programming language that would write code to handle real-time events, and not all of those can be predicted; they thought they had to have capabilities to handle problems no one had foreseen, since Ada was to be used for all Department of Defense programming.

On the other hand, Ada has modularity and variable hiding like Modula-2, and in fact there's more similarities than differences between the languages. They're both nearly self-commenting, too. Certainly they resemble each other more than either one resembles BASIC or FORTRAN. I haven't had enough experience with Ada to get any real feel for it, but from what Ada code I've read, it wouldn't be that hard to learn Ada and get used to working with it.

Another possibility would be Turbo Prolog. Mrs. Pournelle's Reading Program presents lessons and elicits re-

continued

sponses. Then it evaluates the response and does something appropriate, like show a graphics reward, play a tune, go back to review the lesson, or present new material. Since this is all done according to logical rules, it seems to me that Prolog would be a very appropriate language to work in. We expect to develop a whole family of educational programs once the Reading Program is finished, and using Prolog could make that easier.

Finally, there's Trilogy, a new language that combines many of the procedural features of Pascal with the logical operations of Prolog. I haven't had a chance to learn Trilogy thoroughly, but from the little experience I've had with it, I suspect it has great potential for both experimental and production work. It's very fast, and it's actually easier to learn than Prolog; I've been quite favorably impressed, and indeed, if I were going to change languages, Trilogy would be a very strong contender.

It's Still QuickBASIC

After all the thought about new languages, I finally stayed with QuickBASIC. There were several reasons, but

chief among them are that QuickBASIC now has all the data structures and algorithms of any other procedural language—and I already know the BASIC syntax. With all the others, including Turbo Pascal 5.0, I'd have to do some re-learning and lose old habits.

I'd also have to translate about 20,000 lines of code. That's not necessarily bad. I have to recode about half the program anyway, since it was originally written by several people who didn't use the kind of top-down programming structure I like. Still, it's easier to recode from BASICA to QuickBASIC than it is first to learn Prolog or Trilogy, then to figure out how to organize the program along logical rather than procedural lines.

Actually, even that's not necessarily true. Given a solid block of time to sit down and work on the program, I still think I'd be better off starting over, probably with Trilogy; but the trouble is, I don't have a solid block of time. I never get a chance to just sit down and program for several days. I've been working on Mrs. Pournelle's Reading Program in fits and starts, often while on the road; and while the Zenith SupersPort 286 is

more than adequate for programming while traveling, there is a limit to the amount of paperwork and documentation I can haul around. Hotel rooms are not an ideal place for learning new languages.

Thus, I stayed with QuickBASIC, despite its bugs; and bugs it does have.

One of the most annoying bugs showed up only when I ran the compiled Reading Program on a fast 80386 machine that had an 80387 chip in it. The interpreted version—one of QuickBASIC's most attractive features is its ability to run in interpreted mode so that you can do a lot of interactive debugging—ran fine on my Big Cheetah 80386/80387. The code compiled fine. It ran fine on the Kaypro 386i with an 80287 math chip; but when I ran the compiled code on Big Cheetah, I got overflow errors in converting stored graphics images. It wasn't a problem with Big Cheetah, because we got those same errors on a Compaq Deskpro 386 with an 80387. There was something wrong with Microsoft's code generator.

Fortunately, that bug and a number of others were fixed when Microsoft brought out QuickBASIC 4.5. For reasons I don't understand, Microsoft did not inform all the registered QuickBASIC 4.0 owners of the 4.5 update; that is, they not only didn't tell me (and I do send in registration cards, even for review software), but they didn't tell a number of my readers who have written to me about it. So, if you have QuickBASIC 4.0, be sure to get it upgraded.

Version 4.5 also has some bugs—I can still manage to get run-time errors in compiled versions of code that ran fine in the interpreted mode—but there are far fewer of them. Moreover, the documents are better, and the programming environment has been simplified. All in all, version 4.5 is a distinct improvement.

In fact, it's enough of an improvement that, while I still believe that Prolog or Trilogy would be better for the type of program we're producing, I find QuickBASIC good enough; and in line with my view that better is the enemy of good enough, we're doing the full production model of Mrs. Pournelle's Reading Program in QuickBASIC.

A Cautionary Tale

QuickBASIC 4.5 has modularity and separate compilation; that is, you can write parts of your program as distinctly separate modules, completely debug them, and generally check them out; compile them; and put the compiled object code into a program library. You can then incorporate those procedures and

continued



A Brand New Resolution The Handy Scanner HS-3000

Free HALO DPE™

The handiest little scanner in the world just got even better. The Handy Scanner 3000 from DFI offers you clarity and versatility in a little package. Like our other Handy Scanners, the Handy Scanner 3000 for the IBM PC, PS/2s and compatibles can handle almost all the jobs the desktop models can, but it's smaller and easier to use.

We give you the features you need the most in a Handy Scanner. The new 41/8" scanning width makes short work of the biggest pictures. You can switch the scanner between 400/300/200/100 DPI. For those really important pictures, the Handy Scanner 3000 lets you have it all with 400 DPI resolution. The real-time screen display lets you instantly see your scan, so you can quickly make scanner adjustments as necessary. With adjustable half-tones and contrast, you get a clean, clear picture. Two col-

ors, not one, are used to scan your originals, so-called "vivid" as red or reddish skin tones can be scanned without losing detail.

The Handy Scanner 3000 comes complete with full-featured, powerful software for scanning, editing, and merging text with your graphics. Saved scan files are compatible with almost all graphics software, including PageMaker, Ventura, WordPerfect 5.0 and many others. The package includes the scanner, interface card, the HALO DPE desktop publishing software package (worth \$195), a utility diskette and an instruction manual.

The Handy Scanner 3000 is a little scanner that does a lot, and now it does, it even better.

\$299.95

ADDED SPECIAL NOW OCR SOFTWARE AVAILABLE

Converts scanned images from scanner into ASCII text for use with word processors, data bases, etc.

Reg. \$199.95
if purchased with HS-3000 ONLY

\$79.95

LOGITECH SCANMAN

- 200 dpi
- 4" scanning width
- IBM, PC, XT, AT, PS/2 (25 & 30)



Complete with Logitech™ "Scanware"™ Software

\$189.95

QUALITY CUSTOMER SERVICE 506-278-6556

TECHNICAL ASSISTANCE 506-278-6556



TOLL FREE ORDER LINE

1-800-635-0300

TRUE DATA PRODUCTS

115 MAIN ST., P.O. BOX 347
UXBRIDGE, MA 01569
506-278-6555
HOURS: MON-FRI 9-6, SAT. 10-4 (EST)

CORPORATE P.O.'S WELCOMED

ALL PACKAGES SHIPPED UPS EXCEPT CANADA AND A.P.O.'S

C.O.D.'S ADD \$2.30

MASTER CHARGE/VISA ADD 3%

1 YEAR WARRANTY UNLESS OTHERWISE NOTED

PRICES TERMS CONDITIONS SUBJECT TO CHANGE WITHOUT NOTICE

THE NEW STANDARD FOR HIGH PERFORMANCE STATISTICAL SOFTWARE

CSS

**COMPLETE STATISTICAL SYSTEM
WITH DATA BASE MANAGEMENT
AND GRAPHICS**

A powerful, comprehensive, elegant, and super-fast statistical package for IBM (PC, AT, PS/2) and compatible computers. ■ The CSS optimized user interface with fast hierarchical menus incorporates elements of artificial intelligence; even complex analyses require only a few keystrokes (batch processing is also supported). ■ CSS features comprehensive, state of the art implementations of: *Basic statistics, Multi-way frequency tables, Nonparametric statistics, Exploratory data analysis with analytic graphs, Multiple regression methods, Time series analysis with modeling and forecasting (incl. full ARIMA), General ANOVA/ANCOVA/MANOVA, Contrast analysis, Discriminant function analysis, Factor analysis, Principal components, Multidimensional scaling, Item analysis/Reliability, Log-linear analysis, Cluster analysis, Non-linear estimation, Logit/Probit analysis, Canonical analysis, Survival and Failure Time analysis (Censored data), Quality Control analysis, and much more.* ■ All statistical procedures are integrated with fast data base management and instant, presentation quality graphics (over 100 types); full support for all mono and color graphics boards (incl. VGA) and over 100 plotters and printers (incl. the HP and Postscript standards). ■ All CSS screen output is displayed via customized Scrollsheets™ (i.e., dynamic, user controlled, multi-layered tables with cells expandable into pop-up windows); all numbers in a Scrollsheet™ can be instantly converted into a variety of presentation quality graphs; contents of different Scrollsheets™ can be instantly aggregated, combined, compared, plotted, printed, or saved. ■ The flexibility of the CSS input/output is practically unlimited: CSS offers an intelligent interface (read/write) to all common file formats (Lotus, Symphony, dBI, dBIII+, DIF, SYLK, ...) and special utilities to easily access data from incompatible programs; graphics can be saved in files compatible with desktop publishing programs (Aldus, Ventura). ■ CSS data files can be as large as your operating system (DOS) allows; OS/2 version coming soon. ■ CSS precision exceeds the standards of all common precision benchmarks. ■ *Technical note: The CSS user interface and all I/O were written in Assembler and bypass DOS; graphics and data management were written in Assembler and C; the computational algorithms were written in Assembler and optimized Fortran.* ■ \$495 (plus \$5 sh/h); 14-day money back guarantee.

Circle 265 on Reader Service Card



StatSoft

2325 East 13th Street ■ Tulsa, OK 74104 ■ (918) 583-4149

Fax: (918) 583-4376

Overseas Offices: StatSoft of Europe (Hamburg, FRG), ph: 040/4200347, StatSoft UK (London, UK), ph: 0438/310056 or 316561, StatSoft Pacific (Melbourne, Australia), ph: 613-663-6580
Available From: Egghed Discount Software, Corporate Software and other Distributors Worldwide

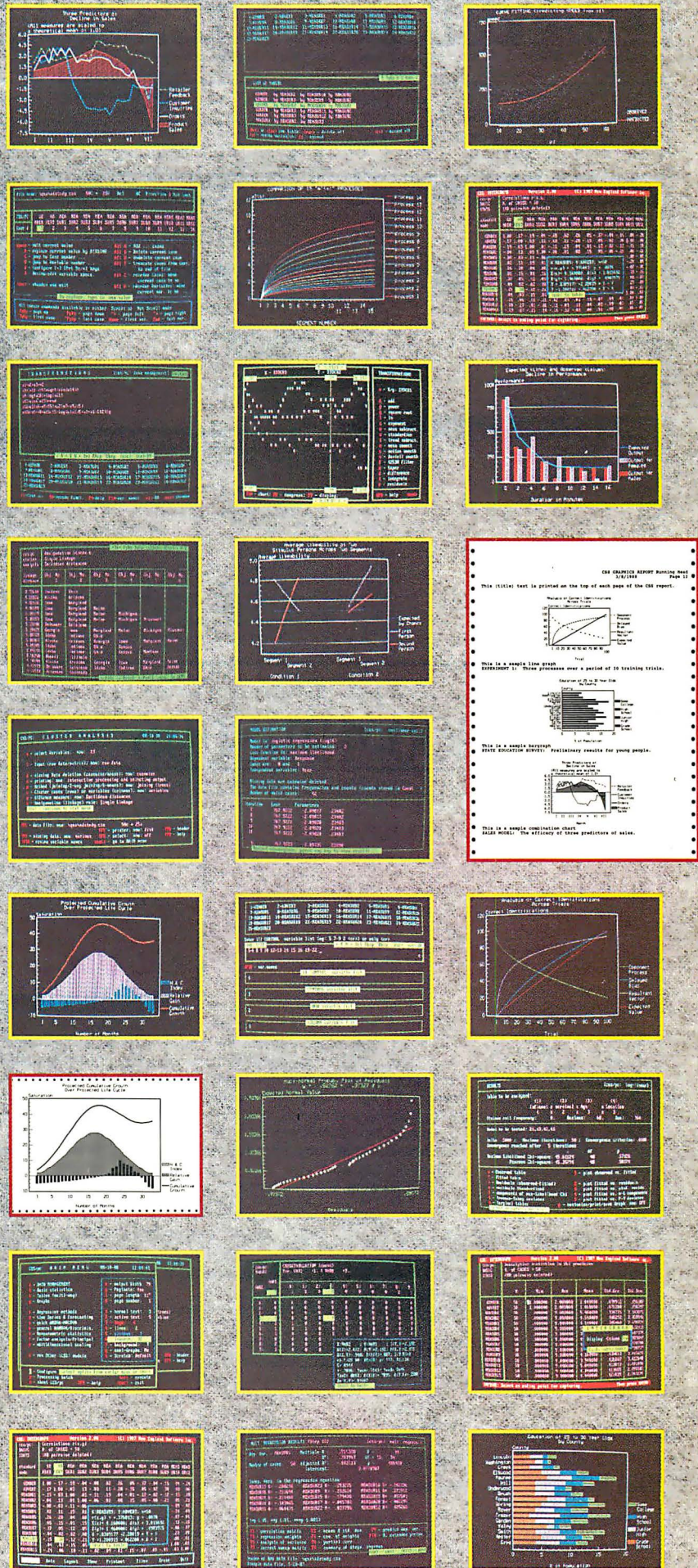

THE PROGRAMMER'S SHOP

helps save time, money, and cut frustrations. Compare, evaluate, and find products.

See you in
San Francisco!
Software Developer's Conference
Booth #103, Feb. 14-17

New Discovery
QuickC 2.0
by Microsoft. Features faster (2-3x) incremental compilation and linking, integrated assembler, extensive hypertext-based on-line help. Support all memory models from within integrated environment. CGA/EGA/VGA/ Hercules support. \$69

Assemblers

	List	Ours
MS Macro Asm	150	105
Turbo Assembler/Debugger	150	115
Visible Computer 80286	100	89

C Language - Compilers

AZTEC C86 - Commercial	499	Call
High C-286 - by MetaWare	595	Call
Instant C/16M	795	699
Lattice C - V3.4	450	289
Microsoft C 5.1 - w/CodeView	450	299
Microsoft QuickC 2.0	99	69
Turbo C - by Borland	150	115
Turbo C Professional	250	179
Watcom C6.5 - highly optimized	295	Call

Dbase & Tools

Buzzwords Toolboxes	295	249
CLEAR+ for dBASE	200	159
Clipper Summer '87	695	449
dBASE IV	795	529
Dbase Online	99	89
dBMAN V	190	179
dBRIEF w/BRIEF	275	Call
dBug - source debugger	195	179
Documentor	295	239
DBXL Interpreter	199	149
FoxBASE+ - V2.1	395	259
Genifer - code generator	395	259
R&R Relational Report Writer	149	139
SoftCode w/dBASE templates	80	69
QuickSilver Diamond	599	369
UI Programmer	295	239

Debuggers

	List	Ours
Periscope II - breakout switch	175	139
Periscope III - 10 MHz version	1395	1119
Sourcer	100	89

Editors

BRIEF	195	Call
COMPEDITOR	175	165
Edix	195	159
Epsilon - like EMACS	195	159
KEDIT - like XEDIT, V.4	150	125
Personal Rexx	125	109
MKS VI	149	129
PI Editor	195	159
SPF/PC - V2.0	245	189
Vedit Plus	185	129

Text Screen Addons

C Worthy w/forms	295	Call
C-scape	399	379
Curses - by Aspen Scientific	119	109
with source	289	275
Greenleaf DataWindows	295	219
for OS/2	395	299
Vitamin C - source, menus	225	169
for OS/2	345	279
Vermont Views - replaces WFD	395	349
with source	790	659

Note: Mention this ad. Some prices are specials. Ask about COD and POS. Formats 3" laptop now available, plus 200 others. UPS surface shipping add \$4/per normal item. All prices subject to change without notice.

functions into new programs. Provided that you really did have things properly debugged, you'll never have to fool with your old code again. When it comes time to compile a program that incorporates your precompiled procedures, first compile the new parts, then tell the Linker where to find the proper library.

This is one of QuickBASIC 4.5's more attractive features. The general notion is that when you write a program, you ought to write it such that much of the code can be used again in other programs. This saves a lot of work and lets you get new programs going faster.

There's one problem. The Microsoft program to build libraries isn't especially easy to use. It's not complicated, but building a library of many different routines can be quite tedious; I've often wished for a program that would make it simpler to make new libraries or change the contents of old ones.

Then I got QuickBASIC Tools from Project X Software. This looked to be the answer to my prayers. Not only did the product include a library-construction program, it also had a whole bunch of precompiled and presumably debugged procedures and functions that I could incorporate into my QuickBASIC program. There were over a hundred of these subprograms, and nearly every one of them appeared useful.

There were routines to check on the existence of a file. Routines to get and change the date of a file. Routines to open dialog boxes and get responses. Routines to get characters from the keyboard and check to see if those characters were in a previously specified set (so that you can, for instance, demand that the user enter either Y, y, N, n, Q, or q, and the routine will ignore any other input). Routines to open, close, rename, and copy files. Routines to make different beeps and chirps. Routines to manipulate dates and return day of year or Julian day, or reformat the date from U.S. to European style.

All of these are available as callable subprograms or functions. No need to write your own: simply use the library manager to choose the routines you want, and let that manager program not only build you a library containing only what you want, but also build you an include file of the proper DECLARATIONS. Some of the functions duplicated stuff I'd already written, but they looked to be more compact. Others were things I'd wanted to include in the program but either hadn't gotten around to or had reluctantly decided I wouldn't have time to

continued

Established 1983. We carry over 1,100 different products. Call today for complete technical information and advice, our catalog, literature, and solid value.

5 B Pond Park Road
Hingham, MA 02043
Mass. 800-421-8006
or 617-740-2510 2 891
Telex: 671 5248
FAX: 749 2018

800-421-8006

HOURS:
M-F 8:30-8:00
Sat. 10:00-4:00

UTAH

COBOL™

NEW VERSION 5.0

\$69.95



For IBM® PC's, XT's, AT's and other DOS machines. Needs only 1 disk drive and 128K memory. This is the one you've heard so much about - with fast compile times, small object code modules, not copy protected, no royalties, and clear error messages. Version 5.0 is based upon ANSI-74 standards with new dynamite features including:

- Nested IF's and nested conditions.
- Indexed files (ISAM) with up to 24 keys (includes START verb). This advanced feature requires the software package Btrieve® which is optionally available.
- ACCEPT (line, column) numerics with decimal point alignment, numeric

checking, AUTO-SKIP, SECURITY, LENGTH-CHECK, EMPTY-CHECK, ATTRIBUTE (color), FROM ESCAPE KEY, DAY, DATE, TIME, DAY-OF-WEEK.

- Fast memory mapped DISPLAY's (line, column) ERASE, BEEP, ATTRIBUTE (color). Can display entire screen with one DISPLAY statement.
- Windowing, pop-ups, color and overlays. This advanced feature requires the software package Saywhat?!™ which is optionally available.
- An easy to use, COBOL source code EDITOR with auto line numbering, A-margin, B-margin tabing with full screen cursor control.

Also available: Utah SuperSort®, a fast sort program callable from Utah COBOL; Utah FORTRAN; Utah BASIC; Utah PASCAL; Utah PILOT. Used by 50,000 professionals, students and teachers in 40 countries. 30-day money back guarantee. Discover the ease and simplicity of COBOL, today!

Phone order rushed by UPS 2nd Day Air: (702) 827-3030



Since 1977
Ellis Computing, Inc.
5655 Riggins Court, Suite 10
Reno, Nevada 89502

IBM is a registered trademark of International Business Machines, Inc. Btrieve is a registered trademark of Novell, Inc. Saywhat?! is a trademark of The Research Group. SuperSort is a registered trademark of Micropro International Corporation. Utah COBOL is a trademark of Ellis Computing, Inc. © 1987 Ellis Computing, Inc.

Built like a Mitsubishi.®



Now there are three great computers built with Mitsubishi quality.

For the perfect balance of size and power on almost any desktop, choose the small-footprint MP286. For the most demanding applications, the 32-bit MP386 has the power, the options and the expandability to perform. And our exciting new MP286L laptop takes desktop power wherever you need it.

They're all assembled in the U.S. for assured delivery and availability and backed with support, training, and applications by your authorized Mitsubishi reseller.

Call toll-free: 1-800-556-1234 ext. 25 (in California, 1-800-441-2345 ext. 25) or write: Mitsubishi Electronics America, Inc., Information Systems Division, 991 Knox Street, Torrance, CA 90502 for the authorized reseller nearest you.

© 1989 Mitsubishi Electronics America, Inc.

See our new product demonstrations at
COMDEX, Booth #3643



Circle 188 on Reader Service Card (DEALERS: 189)

write myself. Consequently, QuickBASIC Tools looked to be exactly what I'd been needing for a long time.

(Unfortunately, after this column was written, Project X Software went out of business. QuickBASIC Tools is no longer available.)

First Problems

Of course, I had a rather old (six months or so) copy of QuickBASIC Tools, but so what? It was supposed to be thoroughly

tested. So, not long before Christmas, I sat down to build myself a library with a dozen of the most useful tools. While I was at it, I'd also use the library manager to link in a couple of general-purpose functions I'd written myself.

The library manager trundled away for a while. I could understand why it took a while. According to Project X, the library manager examines each library function to see if that one calls some other function; if it does, it includes that

new function and looks to see if it calls something not already on the library list. I could see how that feature alone could save me a lot of time.

Eventually, the library manager finished. Rather eagerly—this looked like it was going to make it much easier to finish up Mrs. Pournelle's Reading Program—I invoked QuickBASIC in a way that included the resulting Quick library. (When you build libraries for QuickBASIC 4.5, two are constructed, a regular LIB that's linked into your compiled code, and a Quick library that you use when running QuickBASIC 4.5 in the interpreted mode.) Then, without using any of the new functions, I started up my program. I didn't anticipate any problems. After all, it ran fine the last time I'd used it.

It wouldn't run. There were "unresolved external calls," meaning that the program was looking for functions that were not in its library.

I rather angrily called Project X and got the president (and chief programmer). I explained who I was. He explained first that I had a "very old" copy of their product; and second, that they had just learned that when Microsoft changed from version 4.0 to version 4.5, they made a number of internal undocumented changes in the program. In particular, they changed the names of some of the internal subroutines. Some of these were called by the Project X tools and by the library manager.

However, he said, they had just solved that problem, and they would send me, via Federal Express, the revised product that had been out for several weeks and the newest revisions that would enable it to work with QuickBASIC 4.5. Since there were no changes in the tools themselves, only in some internal stuff, everything should work just fine.

Two Good Days

The new tools came on Friday. Early Sunday morning, we were scheduled to catch the plane to Molokai. Mrs. Pournelle's Reading Program was very nearly done. The only things that remained were polishing it and adding some administrative stuff like keeping records of which students had completed what lessons and a way to set the pass/fail percentage for each student. I was thus eager to get to work, so I opened the revised version of QuickBASIC Tools the instant it arrived.

There were extensive revisions from what I had: lots of new tools and thoroughly new documentation (which, alas,

continued

STOP

and compare our quality and prices!

Our Standards Are Their Options...

**42+ Meg 12 MHz 286
EGA Color System \$1850**

- Samsung 14" EGA Color Monitor
- 12 MHz PC-AT Computer
- Baby AT Case with Key Lock, Turbo, Power and Hard Drive LEDs
- Everex Enhanced Auto Switch EGA Card 640 x 480
- Intel 80286 CPU
- Multi-speed 6/8/10/12 MHz
- Keytronics 101 Enhanced Keyboard
- 640k Memory Expandable to 1 Meg
- 200 Watt Power Supply
- Seagate Model ST251 42+ Meg Hard Disk Drive
- 5 1/4" 1.2 Meg Floppy Drive
- Western Digital 2 Hard Disk and 2 Floppy Controller with Cables
- Serial/Parallel & Game Port
- 80287 Math Co-Processor Slot
- Complete Operations Manual
- One Year Warranty
- Clock, Calendar & Battery Backup

With EGA Multisync (Analog) 800 x 560 **\$2045**
 With Monochrome + 40 Meg (ST-251) **\$1495**



286 16 MHz 0 Wait State Running at 21.0 MHz

**42+ Meg 16 MHz 286
EGA Color System \$2250**

Same System as Above with the Following Differences:

- Running at 21 MHz
- 0 Wait State
- 16 MHz PC-AT Computer
- Multi-speed 8/16 MHz
- Landmark Test of 21 MHz
- 1 Meg Memory Expandable to 8 Meg on the Motherboard
- EMS 4.0

With EGA Multisync (Analog) 800 x 560 **\$2445**
 With Monochrome + 40 Meg (ST-251) **\$1895**

**42+ Meg 20 MHz 386
EGA Color System \$2995**

- Samsung 14" EGA Color Monitor
- 20 MHz 0 Wait State Computer
- Everex Enhanced Auto Switch EGA Card 640 x 480
- AT Case with Key Lock, Turbo, Power and Hard Drive LEDs (Tower Case Available)
- Intel 386-20 CPU (not a 386-16)
- Keytronics 101 Enhanced Keyboard
- 1 Meg Memory
- 220 Watt Power Supply
- Seagate Model ST251 42+ Meg Hard Disk Drive
- 5 1/4" 1.2 Meg Floppy Drive
- Western Digital 2 Hard Disk and 2 Floppy Controller with Cables
- Serial/Parallel & Game Ports
- Math Co-Processor Slot
- Complete Operations Manual
- Clock, Calendar & Battery Backup
- EMS 4.0

With 386-20 MHz EGA Multisync (Analog) 800 x 560 **\$3190**

DOS 3.3: \$79 DOS 4.0: \$109

All Systems Also Available with VGA

ieee, inc.

17120 DALLAS PARKWAY, SUITE 212
DALLAS, TEXAS 75248

To Order, Call

1-214-931-3777

TERMS: One year warranty (12 months parts/12 months labor). 30 day money-back guarantee (excluding shipping charge). We accept **Visa, MasterCard, Discover** (add 3% for credit cards), cashier's check, money order, wire transfer and personal checks (personal checks, please allow 10 working days to clear). Shipping and insurance extra. Prices and availability subject to change without notice. IEEE reserves the right to substitute equivalent or better products. No COD's accepted. 15% restocking fee on unauthorized returns. IBM XT/AT are trademarks of IBM Corp. HOURS: (Central Time) 9 a.m.-7 p.m. Mon.-Fri., 9 a.m.-5 p.m. Sat.

MEMBER
•
DALLAS CHAMBER OF COMMERCE

Compuclassics

WE WELCOME INTERNATIONAL ORDERS

1 818 705-4885 FAX

SOFTWARE

ALDUS	
Pagemaker 3.0.....	519.00
AMERICAN SMALL BUSINESS	
Design Cad.....	159.00
Design Cad 3D.....	159.00
ASHTON TATE	
Multimate II.....	279.00
Dbase IVs.....	489.00
Dbase IV Developers Edition.....	849.00
Framework III.....	429.00
Master Graphics.....	299.00
ASK SAM SYSTEM	
Ask Sam.....	179.00
AUTODESK	
Autosketch Enhanced.....	65.00
BANNER BLUE	
Org Plus.....	59.00
BLAISE COMPUTING	
Turbo Power Tools Plus.....	85.00
Turbo Async Manager Plus.....	119.00
C Tools Plus.....	85.00
C Async Manager.....	119.00
BLOC DEVELOPMENT	
Formtool W/Greatest Hits.....	59.00
BORLAND	
Sprint.....	129.00
Sidekick Plus.....	135.00
Quattro.....	165.00
Reflex.....	99.00
Turbo Prolog.....	99.00
Turbo Basic.....	69.00
Turbo C 2.0.....	99.00
Paradox V 5.0.....	479.00
Turbo Pascal 5.0.....	99.00
Turbo Tutor.....	49.00
BOURBAKI	
1 Dir Plus.....	55.00
BRIDGEWAY PUBLISHING	
Fasttrax.....	35.00
Menu Block.....	62.00
BRODERBUND	
Print Shop.....	35.00
Memory Mate.....	45.00
BUTTONWARE	
PC File +.....	45.00
PC File DB.....	69.00
CENTRAL POINT	
Copy II PC.....	25.00
Copy II PC Option Brd Dlx.....	109.00
PC Tools Deluxe.....	39.00
CHRONOS SOFTWARE	
Who What When.....	125.00
CHIPSOFT	
Turbo Tax.....	49.00
Turbo Tax State.....	29.00
Turbo Tax Professional.....	229.00
Turbo Tax Professional State.....	149.00
CLARIS	
Nutshell Plus.....	219.00
COMPUTER ASSOCIATES	
Supercalc V.....	319.00
Superproject Expert.....	445.00
ACCPAC BPI.....	259.00
Silverado.....	99.00
CONCENTRIC DATA SYSTEMS	
R & R Relational Report.....	109.00
CORE INTERNATIONAL	
Corefast.....	89.00
DAC	
Easy Accounting 3.0.....	59.00
Easy Payroll 3.0.....	59.00
Bonus Pack 3.0.....	115.00
DATASTORM	
Procomm Plus.....	49.00
DBFAST	
Dbfast Compiler.....	62.00
DELFINA	
Perform.....	155.00
DIGITAL RESEARCH	
Gem Desktop.....	32.00
Gem Draw Plus.....	179.00
Gem 1st Word Plus.....	119.00
Presentation Team.....	285.00
Desktop Publisher.....	175.00
Gem Artline.....	285.00
DIGITALK	
Smalltalk V.....	75.00
Smalltalk V 286.....	145.00
DYNAMIC ASSOCIATES	
PC Anywhere III.....	89.00
EXECUTIVE SYSTEMS	
X Tree Pro.....	69.00

FIFTH GENERATION	
Fastback Plus.....	109.00
FORMWORK	
Formwork w/Fill & File.....	89.00
FOX SOFTWARE	
Foxbase Plus.....	199.00
Foxgraph.....	175.00
Foxbase Multi-user.....	299.00
Foxbase Runtime Unlimited.....	265.00
FUNK SOFTWARE	
Always.....	95.00
Sideways.....	40.00
GENERIC SOFTWARE	
Generic Cad Level 3.....	55.00
Dot Plot.....	27.00
Auto Convert.....	27.00
Auto Dimension.....	27.00
3D Solid Modeling/Rendering.....	179.00
GIBSON TECHNOLOGY	
Spinwrite.....	52.00
GOLDEN BOW	
V Feature Deluxe.....	89.00
V Cache.....	45.00
HAVENTREE	
Interactive Easy Flow.....	129.00
IBM	
Displaywrite IV.....	299.00
DOS 4.01.....	125.00
INTUIT	
Quicken.....	39.00
LASERGO	
Go Script.....	169.00
Go Script Plus.....	299.00
LATTICE	
Lattice C Compiler.....	229.00
LEADING EDGE	
Word Processor V1.5.....	89.00
LOTUS DEVELOPMENT	
All Products.....	CALL
MATHSOFT	
Mathcad 2.0.....	225.00
MECA	
Managing Your Money 5.0.....	135.00
MERIDIAN TECHNOLOGY	
Carbon Copy Plus.....	115.00
MICROGRAFX	
Designer.....	465.00
MICROLOGIC	
Tornado w/Library.....	79.00
Tornado.....	59.00
MICROLYTICS	
Gofer.....	42.00
MICROPRO	
Wordstar Professional 5.0.....	249.00
Wordstar 2000 Plus.....	259.00
MICRORIM	
Rbase for Dos.....	475.00
MICROSOFT	
Quick C.....	67.00
Word.....	225.00
Quickbasic.....	67.00
C Compiler.....	299.00
Fortran Compiler.....	299.00
Macro Assembler.....	99.00
Learning DOS.....	35.00
Flight Simulator.....	35.00
Excel.....	269.00
Windows 386.....	129.00
MICROSTUF	
Crosstalk XVI.....	99.00
Crosstalk Mark 4.....	125.00
MULTISOFT	
Super PC Kwik.....	69.00
NAUTUCKET	
Clipper.....	439.00
NEW ENGLAND SOFTWARE	
Graph-In-The-Box.....	75.00
NORTH EDGE SOFTWARE	
Timeslips III.....	115.00
PAPERBACK SOFTWARE	
VP Planner.....	55.00
VP Planner Plus.....	129.00
PATTON & PATTON	
Flowcharting II Plus.....	145.00
PAUL MACE	
Mace Utilities.....	55.00
Mace Gold.....	119.00
PC SUPPORT GROUP	
Lightning.....	55.00
Lucid 3D V 2.0.....	89.00
PEACHTREE	
Complete Accounting II.....	159.00
Complete Accounting w/Data Query.....	235.00

PERSOFT	
Ize.....	269.00
Smartern 240.....	209.00
Referee.....	45.00
PETER NORTON	
Norton Utilities.....	50.00
Norton Utilities Advanced.....	79.00
Norton Commander.....	49.00
PRIME SOLUTIONS	
Disk Technician Advanced.....	119.00
Disk Technician Plus.....	79.00
QUAID SOFTWARE	
Copywrite w/Zerodisk.....	55.00
QUARTERDECK	
Desqview 2.2.....	75.00
REFERENCE SOFTWARE	
Grammatik III.....	55.00
RIGHTSOFT	
Rightwriter.....	59.00
SANTA CRUZ OPERATION	
Xenix 286 Operating Sys.....	469.00
Xenix 286 Development Sys.....	405.00
Xenix 386 Operating Sys.....	475.00
Xenix 386 Development Sys.....	539.00
SCITOR	
Project Scheduler Network 4.0.....	439.00
SIMON & SCHUSTER	
New World Writer II.....	99.00
Typing Tutor IV.....	32.00
SOFTCLONE	
Mirror III.....	55.00
SOFTLOGIC SOLUTIONS	
Disk Optimizer.....	42.00
Cubit.....	42.00
Double DOS.....	42.00
@ Liberty.....	169.00
SOFTWARE MASTER	
Flash 6.....	49.00
SOFTWARE PUBLISHING	
PFS First Publisher.....	85.00
Professional Write.....	119.00
Professional File.....	179.00
PFS First Choice.....	85.00
Harvard Total Project III.....	449.00
Harvard Graphics.....	295.00
STORAGE DIMENSIONS	
Speedstor.....	35.00
SYMANTEC	
Timeline V3.....	329.00
Q & A.....	199.00
Grandview.....	179.00
Cambridge Spreadsheet Analyst.....	89.00
TRANSEX SYSTEMS	
Masterkey Unlock.....	92.00
dAnalyst.....	199.00
TRAVELING SOFTWARE	
Laplink Plus.....	85.00
UNISON WORLD	
Printmaster Plus.....	32.00
Art Gallery I & II & III (Each).....	19.00
Newsmaster II.....	55.00
WISEWARE	
Prime Time.....	65.00
WORD PERFECT CORPORATION	
Word Perfect 5.0.....	239.00
Word Perfect Network Server.....	349.00
Word Perfect Network Add-On.....	75.00
Plan Perfect.....	195.00
Data Perfect.....	299.00
Word Perfect Executive.....	119.00
Word Perfect Library.....	65.00
Word Perfect Office.....	259.00
WORD TECH	
DBXL Diamond.....	115.00
Quicksilver Diamond.....	345.00
XEROX	
Ventura Publisher 2.0.....	469.00

HARDWARE

ARRAY TECHNOLOGIES (ATI)	
VIP VGA.....	299.00
EGAWonder 800.....	259.00
AST RESEARCH	
Six Pack Plus 384K.....	269.00
Rampage AT 512K.....	439.00
Rampage Plus 512K.....	559.00
AST 5251/11 Enhanced.....	579.00
ATD ZUCKER	
Monographics Short Card.....	79.00
Memory Expansion 384K.....	219.00
Modular I/O Bare P/S/Clock.....	75.00
Clock Board Standalone.....	42.00

CITIZEN	
1200.....	159.00
MSP 40.....	349.00
MSP 50.....	445.00
EVEREX	
EV 1800 8MHz AT System.....	969.00
EV 1800 10MHz AT 0 Wait.....	1179.00
Evercom II 1200 Modem.....	75.00
Evercom III 2400 Int Modem.....	155.00
Magic I/O For AT.....	59.00
RAM 3000 EMS Expansion.....	99.00
STEP 386 Computers.....	CALL
FIFTH GENERATION	
Logical Connection 256K.....	469.00
HAYS	
Smartmodem 2400.....	465.00
Smartmodem 2400B W/Software.....	465.00
HERCULES	
Hercules Monochrome Plus.....	189.00
HEWLETT PACKARD	
Laserjet II.....	1849.00
Fonts/Cartridges for Laserjet II.....	CALL
INTEL	
Above Board Plus w/512K.....	495.00
8087-3 (5MHz).....	102.00
8087-2 (8 MHz).....	139.00
80287 (6 MHz).....	149.00
80287 (8 MHz).....	219.00
80287 (10 MHz).....	259.00
Inboard 386 PC or 386 AT.....	899.00
80387 (16MHz).....	389.00
INTERNATIONAL BATTERY	
AT Replacement Battery.....	17.50
AST Six Pack Battery.....	3.50
KENNINGTON	
Masterpiece.....	89.00
Masterpiece Plus.....	105.00
Masterpiece Remote.....	115.00
LOGITECH	
Logimouse C7.....	75.00
Logimouse Hi Rez.....	99.00
Logimouse C7 + Paintbrush.....	95.00
Logimouse W/Cad/Paint.....	125.00
Publisher Mouse.....	125.00
Scanman.....	199.00
MICROSOFT	
BUS Mouse W/Paintbrush.....	99.00
BUS Mouse W/Windows.....	145.00
Serial Mouse W/Paintbrush.....	99.00
Serial Mouse W/Windows.....	145.00
MICRO SPEED	
Fast Trap Serial.....	105.00
MOUSE SYSTEMS	
PC Mouse Plus.....	95.00
NEC HOME ELECTRONICS	
Multisync II.....	629.00
ORCHID	
Pro Designer.....	329.00
Pro Designer Plus.....	439.00
PANASONIC	
KX-P1091I.....	209.00
KX-P1595.....	479.00
KX-P1524.....	649.00
KX-1092I.....	365.00
PARADISE	
Autoswitch 480.....	199.00
VGA Plus.....	295.00
VGA Professional.....	509.00
PLUS DEVELOPMENT	
Hardcard 20 MB.....	569.00
Hardcard 40 MB.....	709.00
POLAROID	
Polaroid Palette.....	1499.00
Polaroid Palette Plus.....	2399.00
PRACTICAL PERIPHERALS	
Practical Modem 1200 Internal.....	69.00
Practical Modem 1200 SA.....	109.00
Practical Modem 2400 INT.....	155.00
Practical Modem 2400 SA.....	185.00
SAMSUNG	
Amber Monitor.....	95.00
SEAGATE TECHNOLOGY	
All Products.....	CALL
SUMMAGRAPHSICS	
Summasketch 1201 Plus.....	389.00
SYSGEN	
Ext 5 1/4" Drive (Specify Model).....	289.00
Bridge File for Ext. Drive.....	49.00
TOUCHBASE	
Worldport 2400 Modem.....	269.00
Worldport 1200 Modem.....	159.00
TOSHIBA	
T 1000 Laptop.....	875.00
T 3100-20 Laptop.....	3415.00
P321 SL Printer.....	549.00

ADVANTAGES

- We welcome corporate accounts
- Immediate replacement of defective goods.
- Bulk discounts
- Immediate shipment on purchase orders from qualified government institutions

- (schools and universities included)
- No hidden charges.
- No minimum.

TERMS:

All prices are subject to change without notice. We

do not guarantee compatibility. No surcharge for VISA or MasterCard. 2% surcharge American Express. No returns without RAK. Short shipments must be notified within 48 hours. 15% restocking fee on non-defective goods: \$3.50 C.O.D. charge. Shipping \$4.50 minimum per item, less on bulk orders. (\$8.50 Blue Label.) (Higher for some software or hardware items.)

Call for prices for any software item not included in this price list.

Order desk & technical support open 7 a.m. to 6 p.m. Monday-Friday (PST) 10 a.m. to 2 p.m. Saturday (PST)

P.O. BOX 1588
6934 Canby St., Suite #109-110
Redsea, CA 91335

Telex 929415COMPU UR/Fax 818-705-4885

WE WELCOME INTERNATIONAL ORDERS

1 818 705-1895 US

1 800 231-6603 CA

1 800 328-4473 US

EVERYBODY

But they're not all switching to the database management system you might expect.

In a recent industry survey,* two-thirds of the respondents who intended to buy a DBMS did not intend to buy dBASE.

And, perhaps coincidentally, two-thirds of recent R:BASE® buyers have used another DBMS before.

Why are they switching to R:BASE?

Because nobody really needs a DBMS: they only need what a DBMS can do.

And users find that the friendly facade of other software is fine for questions. But R:BASE has the right answers for their information management needs.

With R:BASE, you can handle all your data management (not just queries) without learning a single command. Our Prompt By Example (PBE) lets you point-and-pick, then R:BASE does the work.

When you find that you're repeating yourself, you automate simply by recording your actions in a macro file.

Or use our application generator to quickly create complete, correct business programs without touching a line of program code.



Data is data, but information is power.

R:BASE gives you that power. And even impartial judges seem to agree: *PC Magazine*, *Software Digest*, *Datapro* and *InfoWorld* all just gave

IS DOING IT.

R:BASE their highest marks.

Because to its ease-of-use, R:BASE adds speed, functionality and data integrity in a combination you don't get with dBASE, Paradox, DataEase, Oracle or any of the other contenders.

R:BASE is optimized for speed, with an intermediate code compiler that makes your applications sing. And a true compiler is on its way.

You can use its English-based language in command mode, to modify programs R:BASE writes for you, or to write your own solutions from scratch.

Simple menus, prompts and our "paint-the-screen" techniques make sophisticated screens, forms and reports quick and easy to create. With R:BASE forms, you can view and update data from several tables at the same time. Create computed fields. Include scrolling regions so you can work with all the data from other tables. Add rules for data integrity.

And R:BASE is relational, so your rules stay with the tables—applications can't avoid or change them. And forms can be set up to cascade changes through related tables. So you can trust the information you get.

We also give you an SQL implementation that even novices can use to create simple yet powerful queries.



And networking is free for up to three users. It's also easy, so any single-user application can be run on a multi-user LAN with a single command. And our advanced concurrency control, unlike earlier-generation auto-refresh in other DBMSs, won't bring your network to its knees when you expand with our Six-Pack or Network Unlimited versions.

Applications that just won't quit.

R:BASE is the second-largest selling PC DBMS in the world, and it's backed by all the training, service and third-party support you'll ever need.

It's providing end-users with the information they need in large businesses and small. On stand-alone PCs and in networks sharing data with minis and mainframes. In insurance and real estate companies, factories and universities, government offices and the storefront down the street.

Check out what R:BASE can do for you with your local dealer, or write: Microrim, Inc., P.O. Box 97022, Redmond, WA 98073-9722.

DO IT.



Call 1-800-624-0810 today.

*Computer & Software News, 9/5/88. Microrim and R:BASE are trademarks of Microrim, Inc. Other products and services mentioned are not. © Microrim, Inc. 1988.

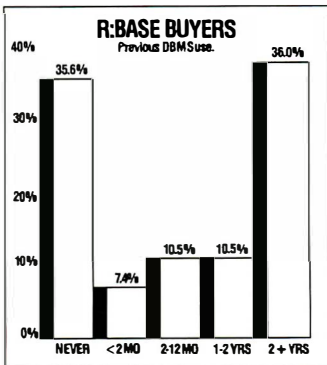

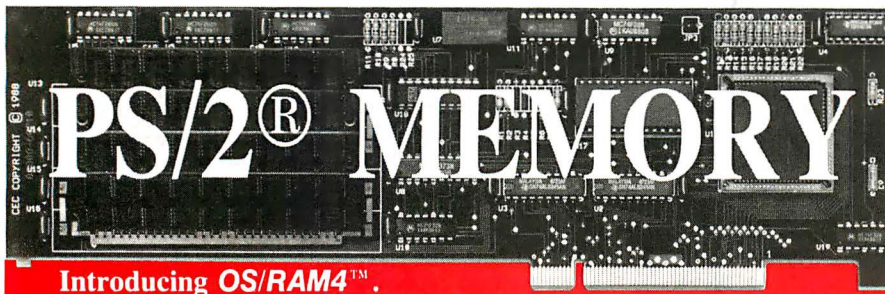

PS/2® MEMORY

Introducing OS/RAM4™

- ✓ 4 megabytes of memory.
- ✓ Extended and expanded memory. LIM 4.0.
- ✓ Works with all of your programs.
- ✓ Run DOS or OS/2 effortlessly.
- ✓ Fast and simple switchless installation.
- ✓ Auto-configuration for all operating systems.
- ✓ Works in all Micro Channel™ computers.
- ✓ Expanded memory 10 times faster than Intel.
- ✓ Risk free guarantee. Two year warranty.
- ✓ IBM approved ID. \$349 0K.

Call today 1-800-234-4232 or 617-273-1818

cec Capital Equipment Corp.
Burlington, MA. 01803

PS/2 and Micro Channel are trademarks of IBM

Wonderful, thought I. First things first: I copied the original lessons and graphics files to the K partition of my Priam hard disk. I already had copies on the WORM drive, and of course Mrs. Pournelle had copies downstairs, both on floppy disks and on the Priam hard disk in her Kaypro 386i, so my latest copy was really gilding the lily; but anyway, I did it. Then I wrote a BASIC program that looked something like the following:

```
FOR i% = 68 TO 34 STEP -1
  j% = i% - 1
  PRINT "Copying Lesson"; i%
  COPY
  (F:\QB4\READ\LESSON.i%,
G:\READ\LESSON.j%)
  COPY
  (F:\QB4\READ\BANNER.i%,
G:\READ\BANNER.j%)
NEXT
```

and so forth. The notion was that I'd build up the correct files on drive G, then copy the whole mess back into drive F, after which I'd be done. The whole thing shouldn't take more than 10 minutes, and the worst that would happen would be that I'd have to go get the stuff off K and start over.

I checked the code several times to be sure it would do what I wanted and told the program to run.

Nothing happened. Nothing at all. After a while, it was obvious that nothing was going to happen.

I hit Control-C. Then Control-Break. Then Ctrl-Alt-Del. None of those produced any result whatever. Finally, I hit the hardware reset on Big Cheetah.

It wouldn't boot. In a mild panic, I turned off the machine, waited a full minute, and turned it back on. It still wouldn't boot.

It was now 11:00 p.m. on a Saturday night. At oh-dawn-thirty we were due to catch an airplane to Hawaii. And Big Cheetah was thoroughly dead.

Corpse Revival

It was probably a good thing that I had to catch a plane in the morning, because otherwise I'd have tried working all night, and I'd probably have made things much worse than they were. Still, I got out my emergency floppy disk, Startup Master, and put that in Big Cheetah's drive A and reset. Nothing happened.

By now, I was in a real panic. Rationally, I shouldn't have been. After all, everything up to late Friday evening was backed up on the WORM drive. True, what I'd worked on all day was probably lost, but heck, it wasn't *that* much, and

was misprinted, not so badly as to be unusable, but badly enough to be frustrating). The library manager was rather different, too, but it was quite easy to use. I got to work building up a new LIB and Quick library.

This time, everything seemed fine. I added a whole bunch of new stuff, including the FILEXISTS function (it rather cleverly looks at the file's date rather than attempting to open it; that way, it avoids having to trap QuickBASIC's "File Not Found" error) and input routines. The Reading Program ran fine in interpreted mode. I kept adding features, particularly disk file stuff and also some provisions for running the program on multiple 360K-byte floppy disks (it takes just under a megabyte to hold the program, administrative files, lesson files, and all the graphics files). I kept testing what I added, and by golly, it was working fine. Friday night I saved everything off onto the Maximum Storage WORM (write once, read many times) drive and went to bed happy.

Saturday I was supposed to pack. Also, Jim Ransom came over to work on our SSX (Space Ship Experimental) briefing. All that was secondary for me, though; I was about to *finish* the Reading Program and get that sucker *out the door*. A great feeling. I worked a good part of the day, paused for dinner, and had at it

again. By 10:00 at night I had it done. Two good days of work.

Disaster

There were two more things to do. One, I'd been running under interpreted mode, and I'd have to compile the program. Second, while I'd been working on the computer program to present the stuff, Mrs. Pournelle had been revising the lessons themselves. In doing it, she'd revised their order and added a couple in the middle of the sequence. The upshot was that of the 70 lessons, about 35 needed to be renumbered. Each lesson is accompanied by two graphics files, so I was really talking about copying and renaming some 105 files. While I could do this by hand, I sure didn't want to, especially since I could describe the changes I needed with a couple of FOR...NEXT loops in BASIC.

The only problem is that BASIC does not have a FILE COPY utility. The only way to copy a file in BASIC is to open it, read it, open an output file under the new filename, and write to that. This isn't all that slow on a Priam 330-megabyte hard disk drive, but it's not all that speedy, either; more important, writing the code at 10:00 p.m. after a long day wasn't very attractive.

However: the Project X tools include a FILE COPY utility.

Special Limited Time Offer.
Save \$100 on every OS/RAM4
with 2 Mbytes or more of memory.



Order today. Call 1-800-234-4232

I want the best PS/2[®] memory, with
the best price and best performance.

Name _____
Company _____
Address _____
City _____ State _____ Zip _____
Telephone _____

✓ I need more information on your

- | | | |
|--------------------------------------|--|--|
| <input type="checkbox"/> OS/RAM4 | <input type="checkbox"/> Warranty | <input type="checkbox"/> Fast shipment guarantee |
| <input type="checkbox"/> OS/RAM8 | <input type="checkbox"/> Installation | <input type="checkbox"/> Risk free guarantee |
| <input type="checkbox"/> Price | <input type="checkbox"/> Quantity discounts | <input type="checkbox"/> Other _____ |
| <input type="checkbox"/> Performance | <input type="checkbox"/> Reseller agreements | |

Return this card or call 1-800-234-4232.

Special Limited Time Offer.
Save \$100 on every OS/RAM8
with 2 Mbytes or more of memory.



Order today. Call 1-800-234-4232



No Postage
Necessary if
Mailed in the
United States

BUSINESS REPLY MAIL

FIRST CLASS PERMIT NO. 381 BURLINGTON, MA

Postage will be paid by addressee:



CAPITAL EQUIPMENT CORP.

99 S. Bedford St. #107
Burlington, MA 01803

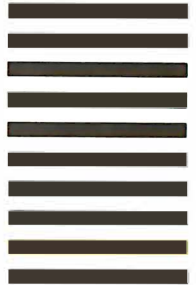

besides, I could pretty well remember what it was I'd done. It wasn't as if I'd been doing creative writing—and yes, I know that sometimes programming can be quite creative, but what I'd been doing hadn't been like that at all, it was just file management stuff, easily recoverable work. All I'd lost was some time.

Still, I was annoyed, and while I didn't see how some software program could permanently harm Big Cheetah, he sure was dead, which was a little scary.

It was now about midnight. I called my son Alex. After all, he's in the data-recovery business. What's the use of having kids with degrees in computer science if you can't bug them in the middle of the night? Actually, he was up, since he keeps about as weird hours as I do.

"Have you looked at the RAM BIOS entries?" he asked.

I blushed to say I hadn't.

"Run the Setup program," he said.

"How can I do that when it won't even look at the floppy?" I muttered, but then I realized that with an Award BIOS, as Big Cheetah has, the Setup program is in ROM; all you need to do is press Ctrl-Alt-Esc during the boot-up sequence and you're automatically put into Setup. I did that.

"Nothing," I reported. "Every entry is blank. Even the time."

"That must have been some COPY utility," Alex said.

I reset the clock and told Big Cheetah that he had a 1.2-megabyte floppy disk in drive A, a 360K-byte floppy disk in drive B, and a "Type 9" 330-megabyte hard disk drive as drive C. Then I tried to boot up.

Big Cheetah looked at drive A, but since the door was open, he tried to boot from drive C. "Bad or missing Command file," I was told. Not good news, but at least we were making progress. I put the DOS 3.3 Startup Master in drive A and reset. Up he came. I couldn't access drive C, or any of the other hard disk drives for that matter, but at least I knew Big Cheetah was alive. At that point I went off to bed. Next morning I caught the plane.

Supercomputers

Hawaii was great. Not only was the conference extremely interesting, but by getting up at 5:00 a.m., while it was still dark, and going out on the golf course in my pajamas, I was able to see Alpha Centauri, the nearest star (and the origin of the Fithp invaders in *Footfall* by Larry Niven and Jerry Pournelle).

It used to be that the only supercom-

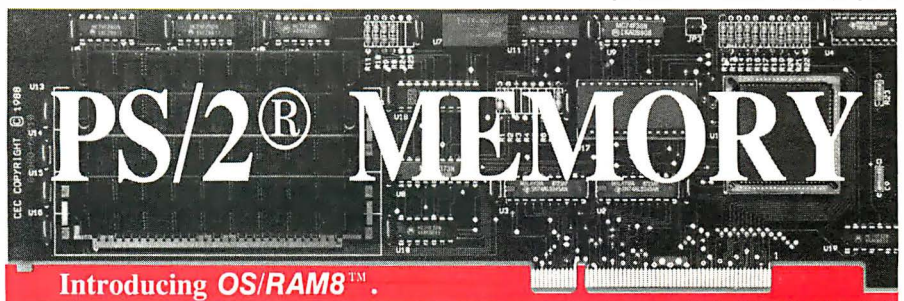

Introducing OS/RAM8™

- ✓ 8 Mbytes of memory + 2 serial ports.
- ✓ Extended and expanded memory. LIM 4.0.
- ✓ Works with all of your programs.
- ✓ Run DOS or OS/2 effortlessly.
- ✓ Fast and simple switchless installation.
- ✓ Auto-configuration for all operating systems.
- ✓ Works in all Micro Channel™ computers.
- ✓ Expanded memory 10 times faster than Intel.
- ✓ Risk free guarantee. Two year warranty.
- ✓ IBM approved ID. \$449 0K.

Call today 1-800-234-4232 or 617-273-1818



Capital Equipment Corp.
Burlington, MA. 01803

PS/2 and Micro Channel are trademarks of IBM

puters were at the National Weapons Laboratories, namely, Lawrence Livermore and Los Alamos. Then some really bright people got to thinking that even when supercomputers become more widespread, there won't be many people who know how to use them because there's no way students, or faculty members for that matter, could get any time on them. From those thoughts grew the National Science Foundation (NSF) Supercomputer Center program.

I am not normally a big fan of government programs. Most not only don't work very well, but they often produce more of the "problem" they were designed to solve. However: let me be the first to say that the nation nearly always benefits from the investments made by the NSF in general, and that the NSF Supercomputer Center program may be the most spectacularly successful government investment since Isabella hocked the crown jewels.

Indeed, if you've a mind to write letters to your Congresscritter, you might mention this program: that it has worked wonders, and the only problem now is that it was so successful that it's underfunded. It needs more resources to put more time in the hands of more people. More important, though, the whole point of the program is to make available the absolutely latest in supercomputer tech-

nology, and the Centers won't be able to do that and expand their grant program at the same time.

We're not talking about billions here. A hundred million dollars a year works miracles. And do understand, we're talking about *investments*, with real and visible payoffs. We don't have any U.S. equivalent of the Japanese Ministry of International Trade and Industry to help U.S. industry against overseas competition, and that's probably just as well: the last time the Department of Commerce got into the act to "help" with the DRAM-chip situation, they darned near ruined the industry. Consequently, the NSF grant programs, which enable our students and faculty members to stay out at the cutting edge of technology, are by a long shot our most effective weapons. They really are important, and they really do work miracles.

I got to see some of those miracles in Hawaii. What has happened is that while supercomputing is still confined to a fairly small community, that community has grown spectacularly in the past few years—and every scientific discipline that supercomputing touches gets revolutionized. Biology, hydraulics, aeronautics, physics; the list goes on.

There's still a lot to be done. There are real problems with operating systems

continued

and languages—most scientific work is done in FORTRAN, and as one physicist put it, after you've written 40,000 lines of FORTRAN, you're too tired to do physics any longer. There need to be software tools and easier user interfaces. Some of that is already happening, as for example at the Illinois National Supercomputer Center, where Director Larry Smarr has interfaced the supercomputers with all kinds of machines, including the Macintosh.

You Too Can Play

I'll have a lot more on supercomputers in the future, but for now, the news is that any legitimate student or faculty member of any U.S. university, college, or junior college who wants time on a supercomputer can get it.

Write Janice Friedland, User Administration Coordinator, John von Neumann National Supercomputer Center, P.O. Box 3717, Princeton, NJ 08593. Ask for either the Education Grant Form

or the Research Institution Grant Form. The education grants are for 2 hours' time and are nearly automatic; they're for the purpose of getting familiar with supercomputers. The research grants go up to 20 hours, and they require a brief proposal for educational demonstrations or small research projects. Review is very rapid.

Janice Friedland can also be reached on Bitnet as FRIEDLAND@JVNCC or on the Internet network as FRIEDLAND@JVNCA.CSC.ORG.

Fill out the forms; if you're a student, get a faculty member to countersign; and the time is free. (You may have to pay for long-distance access, although many academic institutions are already connected through one or another network, and those may be free.)

Incidentally, the National Supercomputer Centers find it amazing that only 1 percent of the academic use of their machines is by computer science and mathematics departments. Most is by engineering departments, followed by physics. Biologists use more time than computer science departments.

Restoring Big Cheetah

Hawaii was fun, but I brooded all the way back, and although we got in late at night, I couldn't wait to work on Big Cheetah.

My first move was to get out Norton Disk Doctor (NDD), put it on a floppy disk, and see what it said about the hard disk drive.

The result was interesting. NDD reported a number of problems, including a damaged partition table, and it offered to fix them. I told it "thank you, no," until I could think it over. The surest way to recover any data off Big Cheetah's hard disk would be to let Alex have at it. Workman & Associates has been able to work miracles in data recovery, but it would be no favor to them to try home remedies first.

On the other hand, Alex is busy, and he wouldn't be able to get at it for a day or so; and after all, I did have WORM drive backup copies of just about everything on that disk. What the heck, I thought, and told NDD to go ahead.

It trundled for about a minute, then it asked me to reboot the machine. This time Big Cheetah admitted he had a drive C—and reported a bad copy of COMMAND.COM. That was easily fixed. By now, Big Cheetah was healthy enough to boot from a 1.2-megabyte floppy disk. I transferred the ESDI disk driver—with a 330-megabyte hard disk drive, you re-

continued

ARE YOU STILL DRAWING FLOWCHARTS BY HAND?

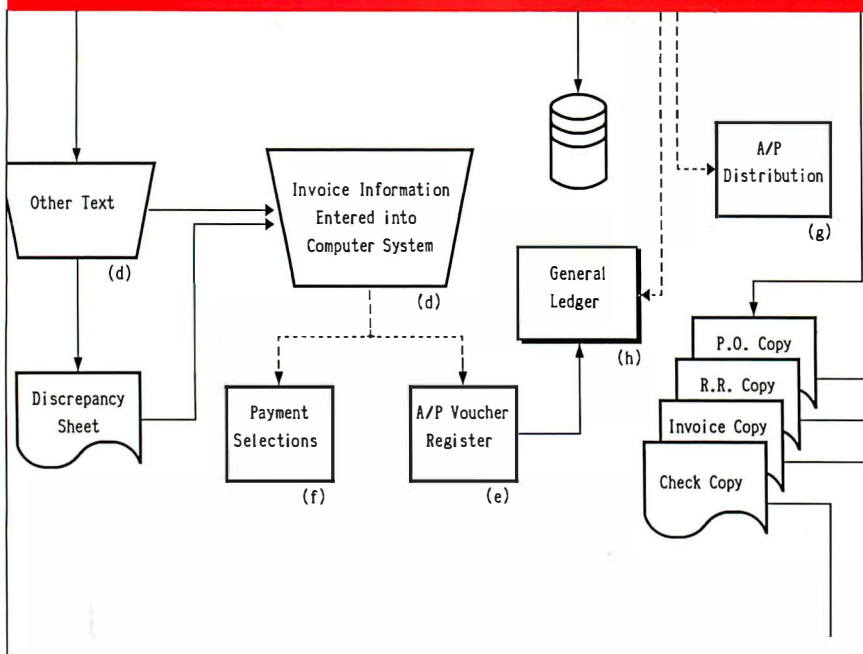

FLOW CHARTING II+

Flow Charting II+ will *amaze* you with its speed, power and simplicity.

- Update and print charts as fast as the situation changes
- See your revisions right away—no long wait for charts to be hand drawn
- Select 26 standard shapes; 10 text fonts
- Tutorial manual makes learning easy
- Runs on IBM or compatibles
- Produces excellent organizational charts!
- Only \$229!

PATTON & PATTON

Software Corporation

Excellence in charting the flow of ideas

For more information, see your local retailer or call
 1-800-525-0082, ext. 47 (outside Calif.) 408-629-5376 (Calif./Int'l.)
 81 Great Oaks Blvd., San Jose, CA 95119

You No Longer Have to Share the Lower 640K With Your Debugger

Periscope I's new board uses ZERO memory in the lower 640K. Yet it has plenty of room to safely store all debugging information, like symbols, as well as the powerful Version 4 software.

Periscope's hardware adds the power to solve the really tough debugging problems.

The break-out switch lets you break into the system any time. You can track down a bug instantly, or just check what's going on, without having to reboot or power down and back up. That's really useful when your system hangs! The switch is included with Periscope I, Periscope II, and Periscope III.

Periscope I has a **NEW** board with 512K of write-protected RAM, user-expandable to 1MB, for the Periscope software, symbol tables, and all related debugging information. Normal DOS memory (the lower 640K) is thus totally freed up for your application, and Periscope is protected from being overwritten by a run-away program. The new board's footprint is only 32K, so you can use it in PC, AT, and 386 systems with EGA/VGA and EMS boards installed (not possible with the previous 56K board). It can also be used with Periscope III to provide additional write-protected memory.

Periscope III has a board with 64K of write-protected RAM to store the Periscope software and as much additional information as will fit. AND...

The Periscope III board adds another powerful dimension to your debugging. Its hardware breakpoints and real-time trace buffer let you track down bugs that a software-oriented debugger would take too long to find, or can't find at all!

The Periscope III hardware-breakpoint board captures information in real-time, so you'll find bugs that can't be found with a software-based debugger.

Periscope's software is solid, comprehensive, and flexible.

It helps you debug just about any kind of program you can write... thoroughly and efficiently.

Periscope's the answer for debugging device-drivers, memory-resident, non-DOS, and interrupt-driven programs. Periscope works with any language, and provides source and/or symbol support for programs written in high-level languages and assembler.

David Nanian, President of Underware, Inc. (of BRIEF fame) says this about the new Periscope Version 4:

"Periscope has always been an unbelievable assembler-level debugger. Version 4 has turned it into a terrific source-level debugger as well. Aside from major enhancements like the source-level improvements, all the little changes make a really big difference, too. For instance, symbol lookups and disassemblies are noticeably faster, and highlighting the registers that have changed really makes life easier. Once again, Periscope has raised the industry standard for debuggers!"

Periscope software & 250+ page manual

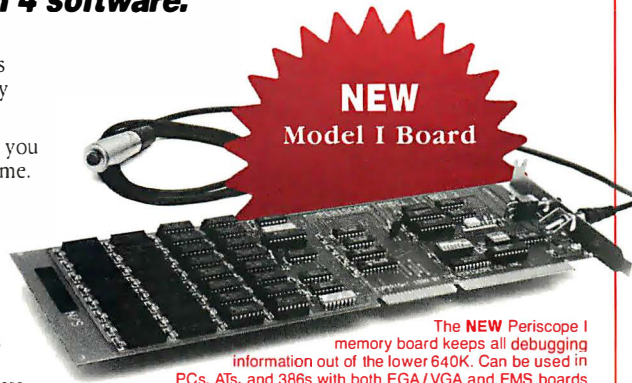
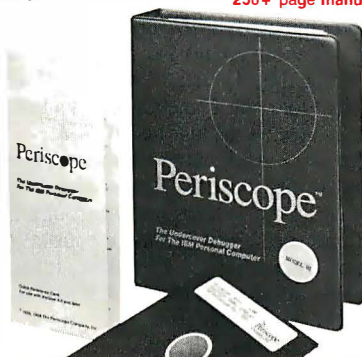

The **NEW** Periscope I memory board keeps all debugging information out of the lower 640K. Can be used in PCs, ATs, and 386s with both EGA/VGA and EMS boards installed. The Periscope break-out switch enables you to recover from a hung system. Included with Models I, II, and III.

What's New in Periscope Version 4:

- View local symbols from Microsoft C (Version 5)
- Debug Microsoft windows applications
- Set breakpoints in PLINK overlays
- Improved source-level support
- Monitor variables in a Watch window
- 80386 debug register support
- Debug using a dumb terminal
- PS/2 watchdog timer support
- Use mixed-case symbols
- Set breakpoints on values of Flags
- Much more!

- **Periscope I** includes a **NEW** full-length board with 512K of write-protected RAM; (user-expandable to 1MB); break-out switch; software and manual for \$795.
- **Periscope II** includes break-out switch; software and manual for \$175.
- **Periscope II-X** includes software and manual (no hardware) for \$145.
- **Periscope III** includes a full-length board with 64K of write-protected RAM, hardware breakpoints and real-time trace buffer; break-out switch; software and manual. Periscope III for machines running up to 10 MHz with one wait-state is \$1395. Plus the new Model I board, \$1995.

Due to the volatility of RAM costs, prices on board models are subject to change without notice.

REQUIREMENTS: IBM PC, XT, AT, PS/2, 80386 or close compatible (Periscope III requires hardware as well as software compatibility, thus will not work on PS/2 or 80386 systems); DOS 2.0 or later; 64K available memory (128K at installation time); one disk drive; an 80-column monitor.

Call us with your questions. We'll be happy to send you free information or help you decide on the model that best fits your needs.

Order Your Periscope, Toll-Free, Today!
800-722-7006

MAJOR CREDIT CARDS ACCEPTED

The
Periscope
Company, Inc.

1197 PEACHTREE ST. • PLAZA LEVEL
ATLANTA, GA 30361 • 404 / 875-8080

Items Discussed

Ada Compiler \$129-\$799	Peabody \$100
Embedded Systems Option \$4500	Copia International, Ltd.
RR Software, Inc.	1964 Richton Dr.
2317 International Lane, Suite 212	Wheaton, IL 60187
Madison, WI 53704	(312) 665-9830
(608) 244-6436	Inquiry 1040.
Inquiry 1036.	
	QuickBASIC 4.5 \$99
FTL Modula-2	Microsoft Corp.
small-memory model \$49.95	16011 Northeast 36th Way
large-memory model \$99.95	P.O. Box 97017
Editor Toolkit \$30	Redmond, WA 98073
Advanced Programmers Kit \$30	(800) 426-9400
Workman & Associates	(206) 882-8080
1925 East Mountain St.	Inquiry 1041.
Pasadena, CA 91104	
(818) 791-7979	Trilogy \$99.95
Inquiry 1037.	Complete Logic Systems, Inc.
	741 Blueridge Ave.
Modula Development System \$249	North Vancouver, BC
(includes Point)	Canada V7R 2J5
Logitech International SA	(604) 986-3234
6505 Kaiser Dr.	Inquiry 1042.
Fremont, CA 94555	
(415) 795-8500	Turbo Pascal 5.0 \$149.95
Inquiry 1038.	Turbo Debugger \$149.95
	Turbo Prolog 2.0 \$149.95
Norton Utilities 4.5 Advanced ... \$150	Borland International, Inc.
Peter Norton Computing	1800 Green Hills Rd.
2210 Wilshire Blvd., Suite 186	P.O. Box 660001
Santa Monica, CA 90403	Scotts Valley, CA 95066
(213) 319-2000	(408) 438-8400
Inquiry 1039.	Inquiry 1043.

quire a special driver that's loaded with CONFIG.SYS—booted up, and did a SYS operation to transfer the system and command file to drive C. After that, Big Cheetah booted off the hard disk. He still didn't believe he had drives D through L, but we were making progress.

I ran NDD again, and again I was told that the partition table was damaged. Once again I let NDD work on it. Lo and behold, drive D reappeared. Another iteration of NDD, and I had drives C, D, and E.

"Piece of cake," I muttered, and tried NDD again.

When the program finished this time, I had drives D through L—but *now*, Big Cheetah steadfastly refused to believe that drive C existed. Nothing I could do would change that. Drive C was gone.

There was worse news. The Maximum Storage WORM drive software has no provision for forcing the drive name to a particular letter. Instead, it automati-

cally becomes the next available drive. When Big Cheetah is working properly, the WORM is drive M; but with drive C "missing," the WORM tried to be drive C, and since it knows it can't be that, it wasn't accessible at all.

Fortunately, my WORM is an external drive, and I have an extra controller card, so it was no trick to run it on the Zenith Z-386. Maximum Storage's installation software pretty well runs by itself. That done, I connected the Z-386's serial port to Big Cheetah's and ran LapLink on both. After that, I was able to peel off all my work from Big Cheetah to anywhere on the Z-386, including the WORM.

After that, Alex came over and managed to restore drive C. As he'd warned me, what he did lost drives D through L in the process. I grabbed off a couple of late files from drive C. After that, it was time to get out the Priam software and reformat the hard disk drive.

That went fine. Priam's latest soft-

ware is supposed to work fine with DOS 4.0, which would let me do away with partitions and have one big 330-mega-byte logical disk drive. (That way, the WORM would be drive D.) Next week, I may try that; but for the moment, I was content to reinstall DOS 3.3 and partition it into drives D through L again. Then I used the WORM (now drive M again) to restore everything.

The upshot was complete recovery. I have been using Priam hard disk drives since 1982, when Bill Godbout, after extensive analysis, decided they would be the best drives for his CompuPro 8/16 systems; indeed, I am still using that original 40-megabyte drive. There's a Priam drive in Mrs. Pournelle's Kaypro 386i, and we've had Priam drives in other systems. Now that Big Cheetah has been restored, I can once again report that I have never lost a single byte of data from a Priam hard disk drive. That's quite a record.

But That's COMMON

First things first. I wrote a large batch file to copy and rename the lesson and graphics files. That was actually a pretty simple job with Logitech's Point editor, which has an easy way to duplicate text. I just wrote COPY F:\QB\READ\LESSON.32 G:\READ\LESSON.31, then used Point to duplicate the line, duplicated the two lines just formed, and so forth until I had 32 copies. Then I adjusted the numbers in each line, duplicated the whole mess, substituted BANNER for LESSON in the second batch, and did all that again to get commands for the third set of files. Obviously, any other good programming editor, such as BRIEF, would have done the job as well. The whole thing didn't take 5 minutes to write, and not much more than that to run.

That put me back where I'd been Saturday night before we left for Hawaii.

There were more surprises. The program ran fine in interpreted mode. It compiled fine. What it wouldn't do was link in a couple of the Project X library modules.

I cursed for a while. Then I went in and removed all their stuff. This forced me to write my own equivalents, which I did; that took me a lot less time than I'd thought it would, demonstrating once again that once you have the actual program structure right, coding is generally straightforward. It all ran fine in interpreted mode.

Of course, QuickBASIC 4.5 wouldn't compile it. This time, the error was

continued

MODULA-2 AND OS/2: PERFECT PARTNERS



"...TopSpeed™ is surely one of the finest new products introduced to date in the PC arena...DDJ doesn't give unqualified raves very often, but there's no question about it in this case: JPI's TopSpeed Modula-2 is first-rate."

Kent Porter
Dr. Dobbs Journal

"JPI Modula-2 looks like another classic in the making. It generates code as good as or better than leading C compilers and the programming environment is a genuine pleasure to use."

Dick Pountain
BYTE Magazine

"JPI TopSpeed is simply the best Modula-2 Software Development System evaluated to date, and must be considered the current leader of the pack."

M. Eugene Haltiwanger
J of Pascal, Ada & Modula-2

In England and Europe contact:
Jensen & Partners UK Ltd., 63 Clerkenwell Road, London EC1M 5NP. Phone: (01)253-4333.
DOS Compiler: £59.95, TechKit £34.95, VID £34.95, DOS 3-Pack £119.95, OS/2 Compiler £124.95.

Handling charges: In UK please phone for VAT & P&P. In Europe, add £6 for up to 3 products, £2 for each add'l product.

OS/2 version now available: Runs in protected mode under OS/2 Standard or Extended Edition 1.0 or 1.1. Generates standard .OBJ files and .DLLs. Comes with fast, smart linker, built-in assembler. Modula-2 and assembly source code for libraries included (and fully compatible with DOS version). Full support of all OS/2 calls. Same integrated configurable environment as the DOS version.

The Compiler Kit includes: High-speed optimizing compiler (3,000-5,000 lines/min. on a PC AT 8MHz), integrated menu-driven environment with multi-window/multi-file editor, automatic make, fast smart linker. All Modula-2 sources to libraries included. BONUS: Complete high-speed window management module included with source. 258-page User's Manual and 190-page Language Tutorial.

VID (Visual Interactive Debugger): An integrated multi-window symbolic debugger for DOS. View source code as it executes. Single-step and trace through multiple modules. Qualify breakpoints with expressions. Examine & modify variables in symbolic form, including arrays, records & pointers. Automatic trace of variables accessed. Includes symbolic disassembler, execution profiler. 78-page manual. (DOS only)

The TechKit™ includes: Assembler source for start-up code and run-time library, JPI TopSpeed Assembler (30,000 lines/min.), TSR module, communications driver, PROM locator, dynamic overlays, and technical information. 72-page manual. (DOS only)

System Requirements: IBM PC or compatible, 384K available RAM, two floppy drives (hard disk recommended).



TopSpeed's seamlessly integrated environment.



VID (Visual Interactive Debugger): power without complexity.

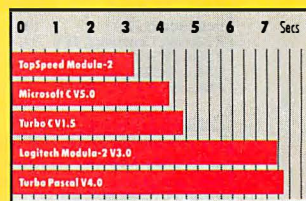

Sieve benchmark measured by the British Standards Institution (BSI) - 25 iterations on an 8MHz AT.

DOS Compiler \$99.95
TechKit \$59.95
VID \$59.95

DOS 3-Pack \$199.95
(Compiler, TechKit & VID)

OS/2 Compiler \$195.00

To Order:

In the US, call:
1-800-543-5202

In Canada, call:
1-800-543-8452

Or mail us your order with a check, money order, or VISA/MC information. 30-day unconditional money-back guarantee.

Shipping & handling charges:

In North America: add \$5 for each product ordered. CA residents please add applicable sales tax. Overseas: Add \$20 for EACH compiler and \$8 for each other product. 3-pack s & h is \$36.00.



Jensen & Partners
International

1101 San Antonio Rd.
Suite 301
Mountain View, CA 94043
Phone: (415)967-3200

TopSpeed and TechKit are trademarks of Jensen & Partners International. Other brand and product names are trademarks or registered trademarks of their respective holders.

Important

UNIX will catch on

Since end of 1988 you don't need star wiring for multi-terminal systems any more. Instead, all those terminals can be connected to a single twin-conductor telephone wire. Neither the terminals nor the computer need be prepared for the bus system - and it won't cost any more than the familiar cabling. This eliminates the main disadvantage of multi-terminal systems as compared with networks. Ask for "Terminal Bus" information.

Terminals/printer up to 3/4 mile away

Electrically isolated line drivers let you set up terminals or printers at distant locations.
22boost, Centronics, 1 pair, 1kV isol.
84boost, RS232, 1 pair, 1kV isolated

Mains filters won't do it all

When computers mysteriously crash, or suffer from lightning discharges, the damage usually arrives along the data lines. Now, opto-isolators that will stand up to 50kV can help you: just interpose them between the computer and its peripherals.
22boost, Centronics, 1kV
66iso, RS422, 500V
88iso, RS232, 1kV
88iso50, RS232, 50kV

Portable Data Buffers

Instrument readings, drilling templates, programs - you can transport all kinds of data in a small, battery-powered buffer.
22b032, Centronics, 32K
22b128, Centronics, 128K
88b032, RS232, 32K
88b128, RS232, 128K

Computers up to 95% faster

Your computer is forced to run with the brakes on because standard printer and plotter buffers are far too small. A buffered data cable will accelerate your computer by up to 95%.
Parallel for PCs:
22i064, 64K
22i256, 256K
22i1024, 1024K
RS232, individually selectable In/Out param.
88i128, 128K
88i512, 512K



The ideal T-switch?

It's so small, it fits into a printer plug - and, naturally, needs no plug of its own. But it will automatically switch a printer between two computers. And it sells so well that just a few lines of advertising are sufficient.
22imca2, 2 PCs to 1 printer

The comprehensive interface program

20mA Atari C64/128 Centr. IBMP IEEE488 RS232 RS422 RS423 RS485		20mA Atari C64/128 Centr. IBMP IEEE488 RS232 RS422 RS423 RS485
---	--	---

New catalogue since Dec. 1st, 88

wiesemann & theis gmbh



THE INTERFACE PEOPLE

Winchenbachstr. 3-5 5600 Wuppertal 2
West-Germany
Telefon: (202) 50 50 77
Telefax: (202) 51 10 50
Telex: 859 16 56 wwd

Austria: Basic 0222-950542 • Belgium: Brother 02-4674211, Info Univera 03-2323247 • Denmark: Jatec 06-479139 • England: Meedmore 051-5212202 • France: Neol 88-623752 • Mexico: Sysper Puebla 489236 • Netherlands: Cat&Korsch 010-4507696 • Switzerland: Weber 01-9302003 • Singapore: Overseas Trade 2726077 • Distributors wanted!

"Module Too Large." That one was simple to fix. I broke the code up into several modules and compiled each. Worked fine. Linked them. Worked fine. Ran the code.

"String Space Corrupt."

A

blooming wonder is what I consider Mathematica to be.

If you look that up in the Microsoft reference manual, it tells you that you've probably made some kind of error in a COMMON statement. I had only one COMMON statement in the doggone program, and all it did was pass a number of universal constants, such as TRUE and FALSE. I could have experimented to see what was wrong now, but I didn't. It took only 5 minutes to rearrange modules so that I didn't need any COMMON statements at all.

Done!

Five minutes later I was done. Mrs. Pournelle's Reading Program is finished. There's about 100K bytes of code. I'll be able to trim it quite a bit by eliminating line numbers and other diagnostic hooks, downsizing arrays, and generally tightening things up; the program should run in a 256K-byte machine. At the moment, it takes about 340K bytes. It also requires either a color or a Hercules graphics monochrome video card.

There's still some polishing to do. The documentation is Mrs. Pournelle's problem, but she pretty well hammered that out in beta testing. I may add touches like help files. What we do have right now, though, is a stable program that will enable just about anyone who can read English to teach just about anyone else.

The highly structured program uses intensive sequential phonics. In addition to the program and a computer, there must be an instructor present to read the on-screen lessons and instructions. The instructor need not be a trained professional, or even an adult.

There are 70 lessons. Each takes a minimum of 20 minutes. (Since the program is self-paced with built-in rewards, we can't specify a maximum.) At a nor-

mal pace of one lesson a day, with reasonable time for weekends and review, that's 90 days to full reading ability.

Of course, it will take longer in special cases, and we suppose there must be cases (particular pupils or combinations of instructor and pupil) where it won't work at all—although we've never seen one. It does take patience and persistence, but then, all education does.

Mrs. Pournelle's Reading Program (IBM PC version 1.0) is available from Roberta J. Pournelle, 3960 Laurel Canyon Blvd., Suite 372, North Hollywood, CA 91604. The current price is \$100 postpaid. We haven't the remotest idea of what the final price will be or, for that matter, who the publisher will be.

Winding Down

I'm writing this on the SupersPort 286 in the San Francisco Hilton. We're up here for the annual meeting of the American Association for the Advancement of Science, followed by MacWorld Expo. A lot of exciting things are happening in the world of science. One that's particularly relevant to computer users is Mathematica from Wolfram Research. As of this week, there's an 80386 version, as well as versions for the Mac and the NeXT machine. The program is a blooming wonder. More on it next month.

The book of the month is Edith Efron's *The Apocalypitics* (Simon and Schuster, 1984). This is a long but fascinating scientific detective story that should be must reading for anyone intelligently concerned about environmental quality, which, I hope, means every voter. As Efron says, laypeople can't make scientific judgments; but we do have to understand the costs and benefits of rules and regulations.

Now I have to get back to MacWorld Expo. Tonight, we drive back to Hollywood. I confess I can't wait to get back. I've thought of a couple of final touches that I can put on Mrs. Pournelle's Reading Program, and I want to play with Mathematica. ■

Jerry Pournelle holds a doctorate in psychology and is a science fiction writer who also earns a comfortable living writing about computers present and future. Jerry welcomes readers' comments and opinions. Send a self-addressed, stamped envelope to Jerry Pournelle, c/o BYTE, One Phoenix Mill Lane, Peterborough, NH 03458. Please put your address on the letter as well as on the envelope. Due to the high volume of letters, Jerry cannot guarantee a personal reply. You can also contact him on BIX as "jerrypp."

The Wait is Over.

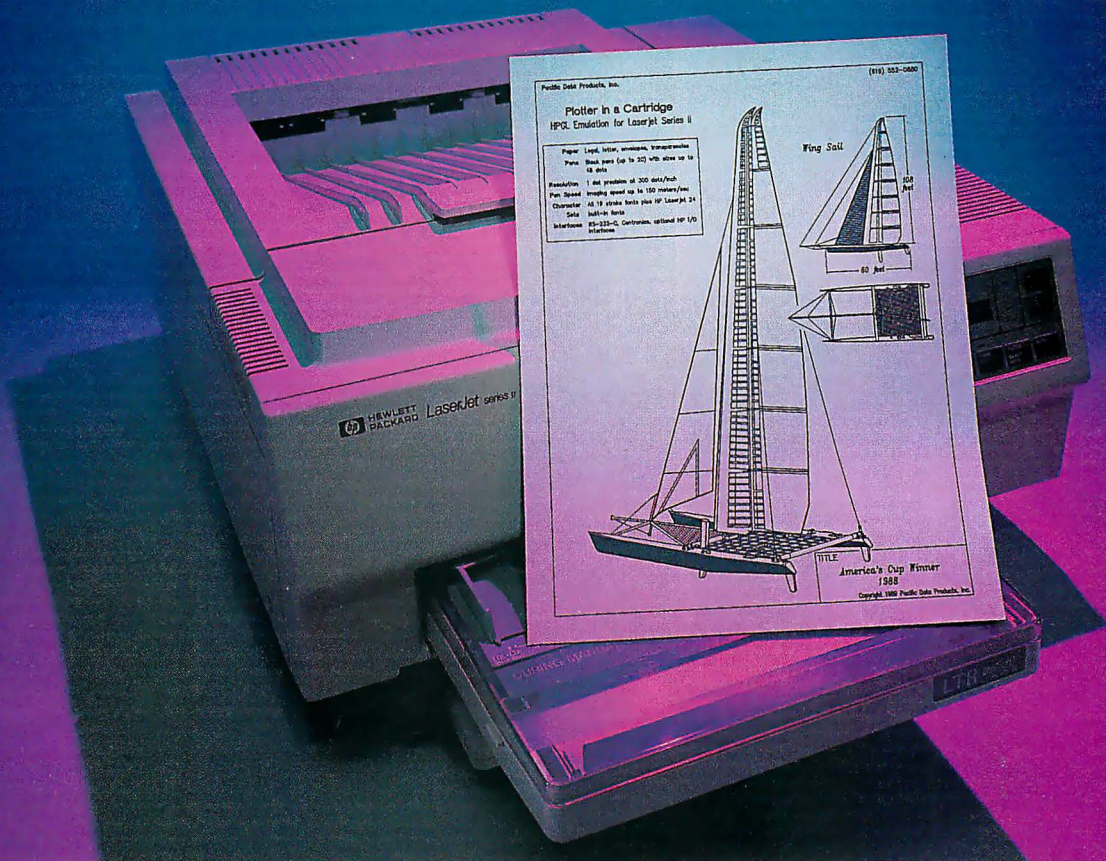

HPGL
Emulation for HP's
LaserJet Series II

Now you can produce precise, high quality plots without the wait required by pen plotters or PC-based emulations. Pacific Data's *Plotter in a Cartridge* is the newest and fastest way to emulate HPGL on your laser printer. In fact, it's as much as 100 times faster! Complex engineering or architectural plots taking 10 to 20 minutes on a plotter can be completed within 10 seconds! Crucial when multiple revisions and check plots are needed.

But there's more to *Plotter in a Cartridge* than speed. In addition to standard pen plotter features, *Plotter in a Cartridge* enables you to define 20 pens and 48 widths, automatically scales to fit envelopes, letter and legal size paper and improves resolution to 1/300 inch. And, you can produce up to 99 quality copies and use virtually any media source.

Because the cartridge plugs right into your printer, you can plot directly from CAD/CAM, engineering, or graphics software.

Plotter in a Cartridge combines plotter precision with laser speed.

PACIFIC
DATA PRODUCTS

6404 Nancy Ridge Drive, San Diego, California 92121
Tel: (619) 552-0880, Fax: (619) 552-0889

Pacific Data Euro, Ltd., Europe
Tel: (44-0734) 391222, Fax: (44-0734) 393871

Mitsui Computer Ltd., Australia
Tel: 61 02 452 0452, Fax: 61 02 452 0481

Pacific Technology, Singapore
Tel: 2615609, 2654888, Fax: 2640371

Plotter in a Cartridge is an unregistered trademark of Pacific Data Products, Inc. HPGL and LaserJet Series II are registered trademarks of Hewlett-Packard. Copyright 1989 Pacific Data Products.

Circle 205 on Reader Service Card (DEALERS: 206)

APRIL 1989 • BYTE 127

CLEO is your SNA, BSC and Coax Gateway

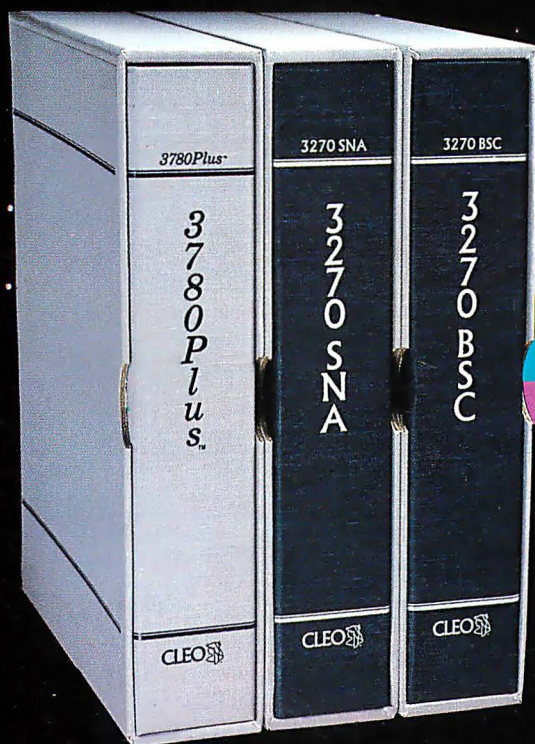

VMS
UNIX
XENIX
PC-DOS
Macintosh
NetBios LAN

Sharing Information

Whatever your industry, your computers need to share information with your mainframe. Or, they need to exchange data with other computers. In either case, you need a total communications solution. You need software, hardware interfaces and modems that all work together smoothly. You need CLEO!

CLEO software products allow your computer to communicate with mini-computers and mainframes, and to emulate their workstations. Since 1981, CLEO has provided communications between micros, minis, and mainframes for the automotive, insurance, medical and banking industries. Today over 78,000 CLEO users worldwide are running on all major computer brands. The greatest number of these users run CLEO software on IBM Personal Computers and NETBIOS LANs.

Complete Software/Hardware Package

Every CLEO package contains all the software and hardware accessories you'll need. Your selected CLEO SNA, BSC, or Coax software is packaged with 1) an internal modem card for dial-up applications, or 2) an interface card and cable for use with your existing modem, or 3) a Coax card for local connectivity. There's no waiting for non-CLEO add-ons. And, you get prompt, single-source service.



Package prices range from \$795.00 for most stand-alone packages, up to \$1,995.00 for the 32-user SNA gateway.

Call us today to discuss your application.

CLEO Software
1639 North Alpine Rd.
Rockford, IL 61107
Telex 703639
FAX 815/397-6535

Headquarters:

USA: 1-800/233-2536
Illinois: 1-800/422-2536
International: 815/397-8110

Sales and Distribution:

Benelux: 31 (0) 33-948888
Canada, East: 800/361-3185
Canada, West: 800/361-1210
Canada, Montreal: 514/737-3631
Colombia, S.A.: 12172266
Denmark: 02 94 81 19
England: (0993) 776543
France: 146861136
Italy: (0331) 634 562
Mexico City: 596-5539
Sweden: 468311780

CLEO 



ANSWERS TO MY MAC MESS

Readers rise to defend the Mac and offer solutions to system snafus

In my December 1988 column, I commented that my Macintosh system had become as overburdened and fragile as my MS-DOS system, with frequent crashes and the accompanying sense of insecurity and fear. I pin this problem on a number of factors.

First, there is the proliferation of INITs and cdevs, programs that are loaded at boot-up and modify the available functions of the operating system. Many of these programs are essential to me (e.g., Vaccine, a public domain virus-protection program, and QuicKeys, the keyboard macro program from CE Software), but they occasionally conflict with application programs, the operating system itself, and each other.

Second, Apple's upgrades to the operating system are often somewhat buggy. The maintenance releases that follow major overhauls seem to fix most of the problems, but invariably Apple also changes the rules for software compatibility just enough to make using older applications a risky proposition.

Third, the pressure to bring new products to market sometimes forces developers to release programs before they're thoroughly debugged.

Finally, the increasing size of programs and the dangers of negotiating the minefield of conflicts with other products make bulletproof debugging nearly impossible. Sooner or later, no matter how exacting a vendor's quality-control procedures, some customer somewhere will come up with a set of INITs, desk accessories, and other programs running under MultiFinder that will bring the system to its knees.

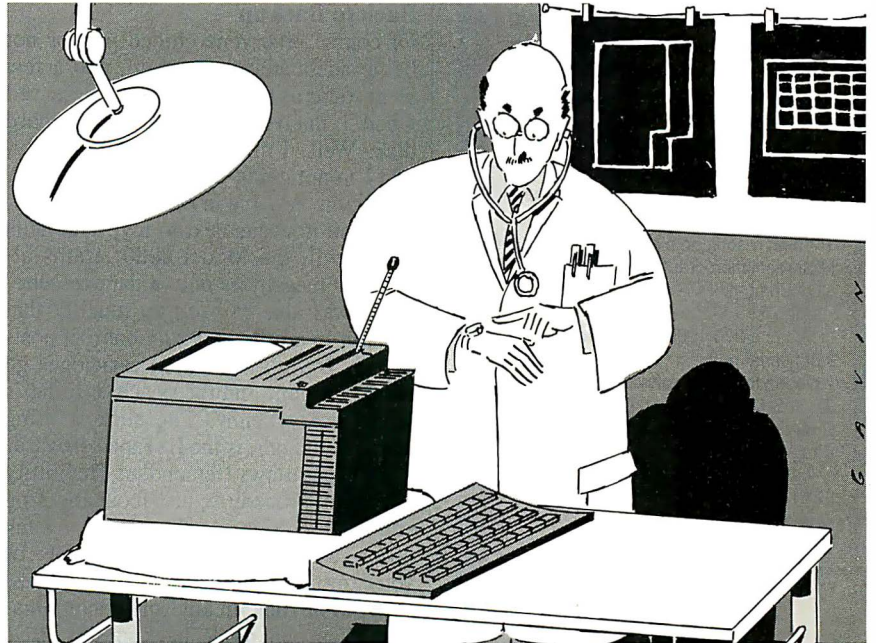

I don't blame anyone for this mayhem, and it's certainly not unique to the Mac universe. I note that Apple and the community of Mac developers have done a good job compared to the confusion that infected the MS-DOS world when memory-resident programs appeared. However, my complaining sparked a spate of correspondence on the subject.

Safe Strategies

One group of letter writers offered a practical solution to my headaches: Don't upgrade the operating system or applications until you're absolutely sure that everything will run amicably. This is really the only strategy that makes sense; and I endorse it wholeheartedly, whether you're running a Mac, an IBM PC, a VAX, or anything else.

If you can possibly do it, stay one or two releases behind the most current offerings and let other people serve as the guinea pigs. Unfortunately for me, it's my business to act as a guinea pig, and

thus I consciously place myself in jeopardy with more willingness than I would were I merely using software rather than evaluating it. I stick my neck out lest others get their heads chopped off.

Other correspondents took umbrage with my bashing of Apple's System software releases as "more bug-laden and crash-prone than Microsoft's MS-DOS updates." I stand by the point, but it's really immaterial; the evil synergy occurs when a number of components are in contention. Even if the Mac operating system was completely solid, which I dispute, the hassles arising from running the mélange of operating system, MultiFinder, new applications, old applications, desk accessories, INITs, cdevs, and so on, stem from the interaction rather than any one piece of the puzzle.

The best advice is to test each component independently before attempting to incorporate it into a complex environment. By being careful and testing exten-

continued



XT Turbo Computer System LIQUIDATION

**20 MB
HARD
DRIVE!**



Zenith, a leader in computer technology, is closing out this line of advanced personal computer systems. We've obtained them & can now offer them to you at UN-BELIEVABLE SAVINGS!!

- 20 MB Hard drive. • 640 K.
- One 720K 3-1/2" disk drive.
- 8088 16 bit microprocessor at 7.16 MHz.
- 84-key keyboard. • IBM compatible.
- 14" high resolution black & white monitor.
- High resolution graphics: 640 x 200
- CGA compatible. • Serial & parallel interfaces. • Mouse port.
- Includes a 300/1200 baud modem & 9-pin serial port.
- Includes following software: MS-DOS 3.2, MS-DOS Manager, GW-BASIC & CPC communications software.
- Dim.: 13"W x 14.5"H x 11"D (without keyboard). • Model #: EZPC 20 plus EZA1 upgrade.
- **One Year Warranty!**
- **Factory New! Factory Perfect!**

**ABILITY SOFTWARE
PKG by MIGENT**

- Includes:
- Database, Spreadsheet, Graphics, Word Processing, Communication & Presentation.
 - Fully integrated.

DAMARK PRICE: \$39

Item No. B-1242-116218
Insured Ship/Hand.: \$5.00

Manufacturer's
Suggested Retail
\$1,999.00

DAMARK PRICE:

\$799

Item No. B-1242-116525
Insured Ship/Hand.: \$29.00

**FOR FASTEST SERVICE
CALL TOLL FREE
1-800-950-9090**



DAMARK INTERNATIONAL, INC.
6707 Shingle Creek Parkway, Minneapolis, MN 55430
Customer Service • 612-566-4940

ZENITH XT Turbo Computer(s)
@ \$799 each, plus \$29.00 s/h each.
Item No. B-1242-116525.

ABILITY Software @ \$39 each, plus \$5.00 s/h each. Item No. B-1242-116218.
MN res. add 6% sales tax.

Name _____
Address _____
City, State, Zip _____
 Check/MO VISA MasterCard Discover
Card No. _____
Exp. Date _____ Ph. # () _____

DELIVERY TO 48 U.S. STATES ONLY

sively, wrote Matthew Dixon Cowles, "I have not, by any means, had to become 'accustomed to the sporadic system crashes that characterize life on the Mac.' And neither have my clients."

OK, fine. I yield. If you adopt a conservative approach, you'll be safe. If you want to waste your time testing every piece of software you own, singly and in combination, or hire a consultant to do the same thing, that's your business. Me, I think this says something about the nature of personal computing these days. Something ugly.

Back to Backup

Of course, everyone chided me for not being adequately backed up, and a few went so far as to say I got what I deserved when I inadvertently trashed my hard disk. Well, I'm not entirely foolhardy, and I'm not going to get caught again. A handsome new Irwin Magnetic Systems' tape unit now sits next to my Mac. This little devil, the Model 5080, crams almost 80 megabytes onto a data cassette, and I was able to back up roughly that amount in a little under an hour. It costs \$1695, Irwin's formatted cartridges go for \$35 a pop, and the peace of mind is worth every penny. The slickest thing about it, though, is the EzTape software.

EzTape allows tremendous flexibility in backup procedure; just about anything you want to do is possible. You can back up or restore an entire disk volume, or you can specify folders, individual files, or types of files, in any sort of combination. You can name backup sets, save rule criteria as parameter files, and perform incremental backups by date or by date of last backup.

The program will run in the background under MultiFinder, and you can configure it to run automatically at a certain time or regularly at a specified period. It will even restore MS-DOS tapes to a Mac disk, or vice versa. (When acting as a file transfer system from Mac to MS-DOS, EzTape will discard the meaningless Mac resource forks and create legal filenames and directory names.) In the past, I've used HFS Back Up, Diskfit, and Central Point Software's PC Tools backup module. This program is as good as any of them.

If you're going to attempt unhealthy maneuvers in an environment that's not rock solid, buy some insurance.

Good-bye, Mousie!

My search continues for an acceptable alternative to the mouse. This month's entry is the MouseStick from Advanced Gravis Computer Technology, a deluxe

Items Discussed

Irwin Model 5080 \$1695
AccuTrak Cartridge \$35
Irwin Magnetic Systems, Inc.
2101 Commonwealth Blvd.
Ann Arbor, MI 48105
(800) 421-1879
Inquiry 1021.

LetraStudio \$495
Letraset USA
40 Eisenhower Dr.
Paramus, NJ 07653
(201) 845-6100
Inquiry 1022.

MouseStick \$169.95
Advanced Gravis Computer
Technology, Ltd.
7033 Antrim Ave.
Burnaby, BC
Canada V5J 4M5
(604) 434-7274
Inquiry 1023.

joystick that lists for \$169.95. I've been experimenting with the Mac Apple Desktop bus (ADB) model, but other versions are available for older Macs, the Apple IIGS, and PC compatibles. It's a nifty gizmo, well built and responsive, but I've had a few trivial snags that temper my otherwise enthusiastic endorsement.

The unit itself is a bit more complicated than I would have expected. A 4-inch contoured, foam-padded stick rises from a base that's 6 1/2 inches wide, 4 3/4 inches deep, and 1 1/4 inches high. The base has rubber feet; that fact, along with its size and weight, makes it difficult to tip in most situations. With the two large thumbwheels front and rear, you can adjust stick tension from stiff and springy down to totally limp. There are three "fire" buttons, two on the base to the left of the stick and one on top of the stick. All three buttons are initially set to generate single mouse-clicks.

A cable leads from the pedestal to another box, about a third smaller than the base, which houses the device's programmable electronics. A 16-character LCD indicates mode settings that enable nearly total control of resolution, tracking, and button function. An ADB cable leads from this GMPU (Gravis MouseStick Processing Unit) to the Mac.

continued

Affordable Large Format Plotting Starting at \$1695.*

A-E
\$2695.
(sugg. ret. \$2995.)

A-D
\$2295.
(sugg. ret. \$2695.)

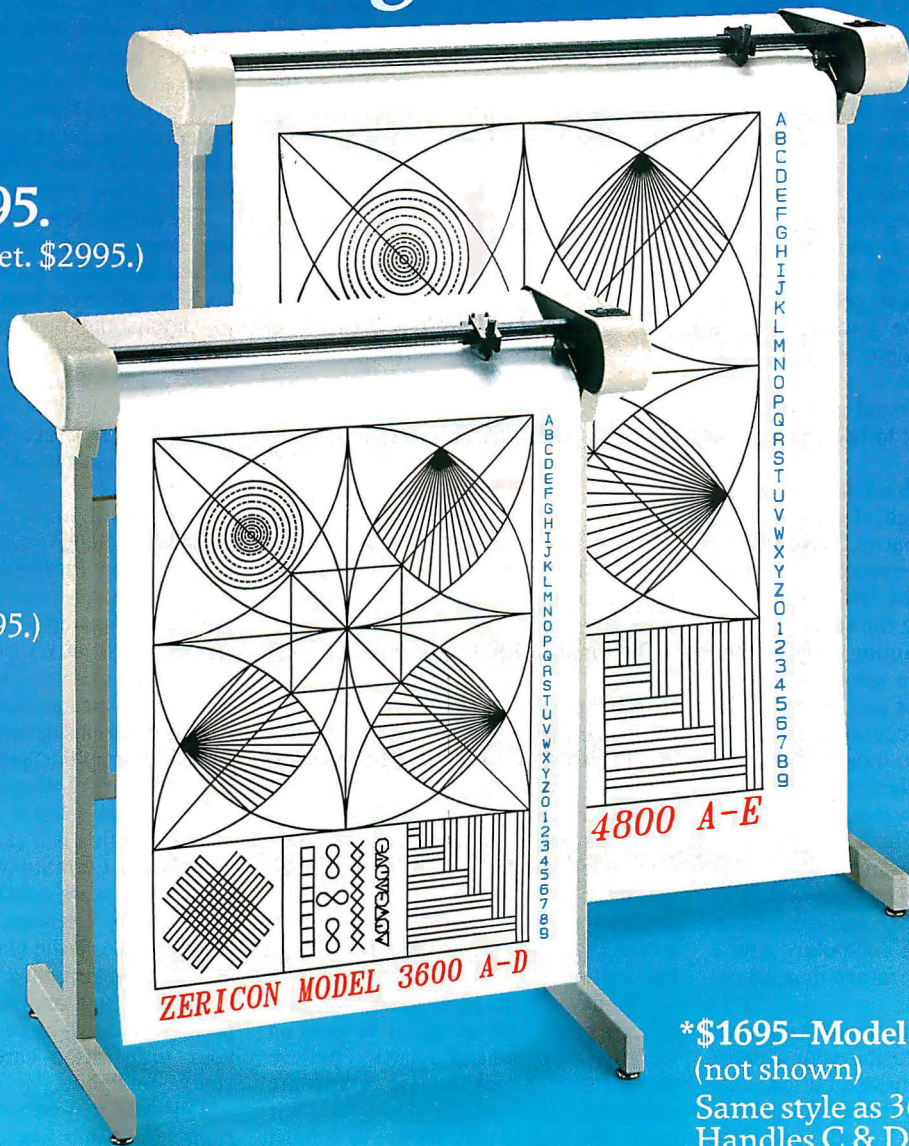

*\$1695—Model 3610 C/D
(not shown)
Same style as 3600 A-D
Handles C & D size media

Features that say value...

Economical: \$1,000 less than other large format plotters.

Compatible: Operates with all popular CAD software supporting DM/PL.[™]

Multiple Media Sizes as small as 8½" x 11" or as large as 36" x 48" eliminates the need for a second plotter.

Practical speed you can really use: 10" per second assures good drawing throughput while optimizing the speed at which most plotter pens can draw without skipping.

Repeatability and Resolution: .004 assures quality suitable for the most demanding applications including PCB artwork.

Vacuum Paper Hold Down guarantees perfect registration.

Unique: X&Y rescaling allows calibration to one part in 10,000. Ideal for applications where scale is critical.

CALL NOW AND WE'LL SEND YOU A FREE SAMPLE PLOT.

(415) 490-8380 Fax (415) 490-3906

International Distributors Invited

ZERICON

40491 Encyclopedia Circle
Fremont, California 94538

Made in USA

DM/PL is a trademark of Houston Instrument

After I had used it for a few minutes, I was convinced that my instinctive approach to the MouseStick, which was to grab the stick in my fist and click the top button with my thumb, like a jet pilot, was useless for anything but game playing. You need far more precision for even the simplest Mac operations, like clicking on an icon or setting the cursor; I felt about as coordinated as someone trying to fill out tax forms with one of those fat crayons they give you in grade school. I had also adjusted the joystick for the highest level of tension, figuring that would give me the fastest, most sensitive response. Instead, I found myself struggling against the stick to hold the cursor in position.

By thoroughly rethinking the way I held my hand, though, I was able to achieve a degree of control I have not experienced with either a mouse or a trackball. Resting my index finger on top of the stick and grasping the shaft between my thumb and remaining fingers, the way you might hold a saltshaker to tap out small quantities of salt, gave me the ability to make tiny, accurate movements with the cursor. I also loosened the tension wheel five notches, to the lowest amount of spring allowable for automatic centering.

Using Aldus FreeHand and Cricket Paint, I actually knocked out a couple of drawings as close to pen and ink as I've ever produced with a computer. And I could sketch quickly, rather than laboring over every line.

With the mouse, you draw with your shoulder and elbow, using your fingertips only to click the mouse button. The trackball cuts down the large muscle movements, but there's still very little wrist involved, and the second gesture necessary to click a button is often awkward and throws off your cursor position. The MouseStick puts it all in your wrist and fingertips; it's very tight and very comfortable. I haven't had enough experience with a stylus and a bitpad to make a knowledgeable comparison, but I'd guess that a skilled MouseStick operator could come close to the effects achieved with a digitizing tablet.

Now for the bad news. The GMPU draws its power directly from the Mac's ADB; there's no internal battery. Any configuration settings you program into it are wiped out when you turn off the Mac. Though running through the setup routine every time you boot the computer is inconsequential, it's irritating. This is pretty dumb; a little bit of RAM and a lithium battery are not too much to ask at this price.

Further, the unit is designed for the game player who wants to play rocket jockey, so even if the MouseStick is built for abuse, the ergonomics don't favor the serious computer user. I'd love to see a reworked MouseStick with a slimmer

I've never
been particularly
opposed to copy
protection.

base, a shorter shaft, and a convenient way to rest your wrist on your work surface.

But for now, I'm very pleased.

Bitten Again

Just when I thought it was safe to go back into the water, I was attacked by that old nemesis, the copy-protection shark. This happened three times in the course of a two-week period, which was quite a surprise. Copy protection has pretty much vanished, particularly in the category of business software, so finding three protected programs all at once is worth a few comments.

I've never been particularly opposed to copy protection; in fact, I've gone on record as something of a hawk. I believe that software companies and authors are entitled to just compensation for their work, and should they choose to combat unauthorized distribution via copy protection, so be it.

Software piracy is rife; almost everyone I know engages in casual swapping on a regular basis. And coping with the various protection schemes is a petty annoyance that has been blown vastly out of proportion. Plugging in a key disk or running through an installation procedure is a momentary hassle at worst. On the other hand, a petty annoyance is still an annoyance. As a user, I choose to avoid the issue by steering clear of protected programs. This is what's known as a "marketing reality." Most vendors have chosen to acknowledge this attitude and unprotect their programs.

Two of the three cases I discovered can be dismissed easily. One was a game that merely requested I type in a certain word from the manual. Rather mild stuff, and certainly reasonable. The second was a

\$5000 package that's normally sold as part of a fully integrated system; it required a hardware key (what's known as a *dongle*) to be plugged into the Mac's modem port. I figure that if the consumers of this product are willing to pay that kind of price, they'll be willing to put up with this kind of nuisance.

The third case was much more disturbing, because the copy protection is attached to a major software package that could be one of the most significant desktop publishing products of 1989. The software is Letraset's LetraStudio for the Mac, a \$495 typographic manipulation program that lets you kern, distort, color, and otherwise make headlines perform tricks you didn't think were possible on a microcomputer.

The resulting modified type is stored in Encapsulated PostScript format, ready for inclusion in files created by most word processing and page layout programs. Compared to the dismal effects you get when you try to blow up standard PostScript-text alphabets to headline size, this is spectacular stuff. Anyone involved in serious desktop publishing, advertising, graphics, package design, and so on will be drooling for this one.

LetraStudio itself is not copy-protected, but this is a classic case of razor and blades. LetraStudio is the razor; because it can work only with special typefaces sold by Letraset, the typefaces are the blades. And the blades are copy-protected. Four reversible installations, but protected. You get two blades with the package and two more when you send in your registration card—anything else you've got to buy.

This hits my fence-straddling position right smack-dab where it hurts. I can't really complain about this scheme on moral or ethical grounds, because I believe Letraset has the right to protect its interests however it sees fit. On the other hand, I need and want this program, and I also want lots and lots of blades for it. While I have never had a single disk mishap due to this sort of protection, these typefaces will be the only things on my hard disk that are copy-protected. Which makes me very, very nervous.

Something to think about, you bet. ■

Ezra Shapiro is a consulting editor for BYTE. You can contact him on BIX as "ezra." Because of the volume of mail he receives, Ezra, regretfully, cannot respond to each inquiry.

Your questions and comments are welcome. Write to: Editor, BYTE, One Phoenix Mill Lane, Peterborough, NH 03458.

One of the most important reasons
for buying our new LaserJet IID printer
is on the other side of this page.

One of the most important reasons
for buying our new LaserJet IID printer
is on the other side of this page.



The latest member of the HP LaserJet printer family prints on both sides of the paper. But that's just the icing on the cake.

The LaserJet IID printer is full of new ideas for making paper-handling easier and more efficient.

An envelope feeder accessory, for one. Instead of having to feed envelopes manually, our new printer does it automatically.

You wanted more paper trays. So the LaserJet IID printer has two of them, each with a 200-sheet capacity. Give us more fonts, you said. And LaserJet

Series II compatibility. Done!

So now you have a choice of two HP LaserJet printers. Both with that superb quality for text and graphics you've come to expect from Hewlett-Packard.

All good reasons to call 1-800-752-0900, Ext. 297A for the name of your nearest dealer.





GROPING FOR GROUPWARE

Group productivity software is designed to make life a little less complicated for busy executives

Group productivity software, or “groupware” as it’s affectionately known, is designed to enhance the functioning of a group in much the same way that individual productivity software helps the individual. The difference is that groupware, to be effective, must enhance the interaction of the people in a group.

Because of the nature of a group of people, groupware faces several challenges. First, people who work together are not necessarily located together. They can be spread across many floors, between buildings, or even in separate cities. Second, a group consists of individuals who may have their own ideas about what work they need to do and how it should be accomplished.

The Parts of the Group

People in a working group interact with each other in two ways that software can help. The first is simple communications. This function is met through the use of a telephone or by E-mail. People also tend to gather in meetings, so they need to set up those meetings. An electronic scheduling package can help.

E-mail is reasonably familiar to most computer users. A good E-mail package should be easy to use, even for inexperienced users, but still capable enough that you can use it to forward word processing and graphics files. It should also allow time and date stamping, multiple addressees, copies, and forwarding. Mail should be password protected, so that someone else cannot send mail while

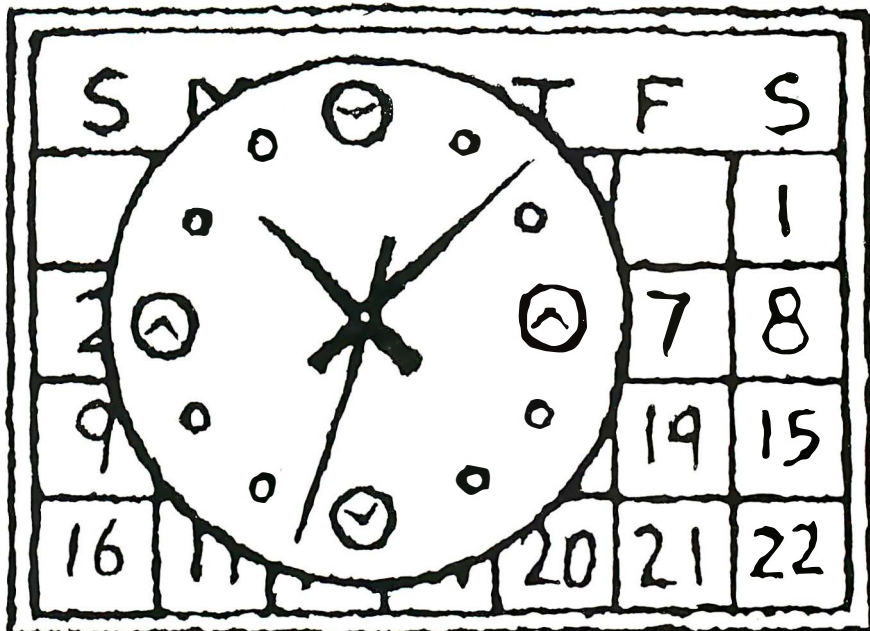

pretending to be you.

An electronic scheduler allows group members to see when others in the group are free. It should have some way of notifying others that you want to have a meeting, and it should be able to automatically find a clear time for all members of a specified group so that they can schedule a meeting. Of course, the ability to do this doesn’t mean that it can be used in every case. Not everyone likes to have others schedule his or her meetings.

Looking at Groupware

For this column, I looked at two packages of group productivity software: WordPerfect Office from WordPerfect Corp., and Higgins from Conetic Systems. These are designed to work on a LAN and to support the users on the network. Higgins has been around for years and is widely used, while WordPerfect Office was introduced only last year.

Both packages provide E-mail and group scheduling and are designed to

provide a shell from which you can perform most other functions, such as word processing. Each contains additional productivity tools designed to make the busy executive’s life less complicated. Whether they do this for you depends on whether your life matches what the company thinks it should be.

I used both packages on an Ethernet network running Novell NetWare 2.12. Both packages are designed to run on most other common LANs, including 3Com, Banyan, and most NetBIOS-compatible networks. Both packages reside on the file server.

WordPerfect Office

WordPerfect Office is the latest entry in what seems to be WordPerfect Corp.’s continuing effort to take over the world. The package is based on a shell that has a two-column screen of choices (see photo 1). Along with the shell, you run a small memory-resident program that will alert

continued

you when it receives mail messages or schedule requests.

The standard shell that comes with WordPerfect Office includes choices for all the included groupware programs, as well as for WordPerfect, PlanPerfect, and DataPerfect (not included; you can easily change the entries for these if you don't have that software). The shell lets you create a menu with up to 20 entries and provides a command line that lets you run anything else you need. For example, you need the command line to perform DOS functions, since none of these are provided on the standard Office menu. Of course, you can add them to the menu yourself, if you wish. The shell requires only about 40K bytes of memory, and it didn't seem to interfere with any other software.

When the shell loads, it is able to tell who you are from the network software, so you don't have to enter your name again, though you do have to enter passwords for the mail and scheduler systems. Otherwise, you can remain in the shell and perform your day's work.

In addition to the scheduler and E-mail, Office contains a calendar program that works in conjunction with the scheduler. This means that people can see whether you're busy, but they can't see the details of your calendar or who you're meeting with. Office also includes a file manager, which lets you search for and copy DOS files; the Notebook, which is a flat-file data manager; and a calculator. There is also a macro editor for WordPerfect and a program editor for batch files and the like. For those long lunch hours, Office also contains a game called Beast, which is nice,

but not nearly as nice as Novell's multi-user Snipes game.

WordPerfect users will feel right at home with WordPerfect Office. Most of the common keystrokes are the same, and the flow of the program is familiar. The editors are quite similar to WordPerfect. The E-mail editing screen follows a message format, but most of the familiar WordPerfect keys work there, too.

Higgins

When you start running Higgins, it lets you know right away that it's groupware: The first thing you see is the group scheduling screen (see photo 2). Other functions appear in windows on your screen, but your calendar is always right there at the top. If you have a busy schedule that you need to refer to a lot, this is really handy.

Likewise, Higgins shines when it comes to E-mail. You can buy optional packages that let you send mail to external systems, to other networks, and to mainframe mail systems. You can even send mail to people who don't have E-mail: If you specify it, Higgins will print the mail message so that you can send it via paper mail.

At the bottom of the screen, a Lotus-like menu gives you access to several applications. Higgins includes additional productivity tools in the form of a calculator, a scratch pad, and an expense program. The expense program seems to be useful, though many companies require specific software or expense voucher forms that would limit the usefulness of the software contained in Higgins.

Unlike WordPerfect Office, Higgins doesn't let you incorporate specific ex-

ternal software into the menu system. Instead, you invoke a command that gives you a command line from which you can run external software. This makes Higgins somewhat less convenient for inexperienced users.

If Higgins has a problem, it's security. When you start up Higgins, it asks you for your name and password. It does not take your name from the network software. Once you enter the password, you need not do it again. This means that if you are going to be away from your desk, you need to leave Higgins, since anyone with access to the computer could enter your mail and scheduling system. WordPerfect Office, on the other hand, requires you to enter a password each time you access mail and scheduling. This means that you can start up the Office shell and stay there all day, since you can run software from there and since others still won't have access to your mail and schedule systems.

On the other hand, Higgins will allow you to have two passwords for your account. You can have one for yourself that allows full functionality and another with partial functionality for your secretary. Higgins also lets you arrange for your nonprivate mail to be forwarded to someone else while you're away.

In general, Higgins is easy enough to operate, although I did find it awkward to use the space bar, rather than the arrow keys, to navigate through the Lotus-like menus.

Grouping the Differences

I found both packages useful. WordPerfect Office suited me better, but as in the

continued

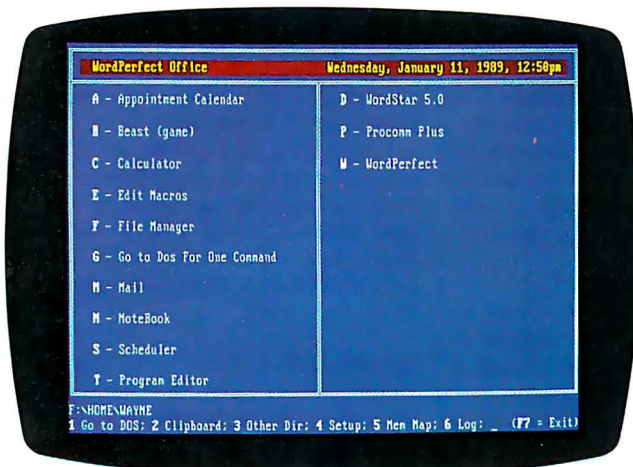

Photo 1: WordPerfect Office's menu lets you choose from several built-in programs or create menus of up to 20 choices from your own application programs.

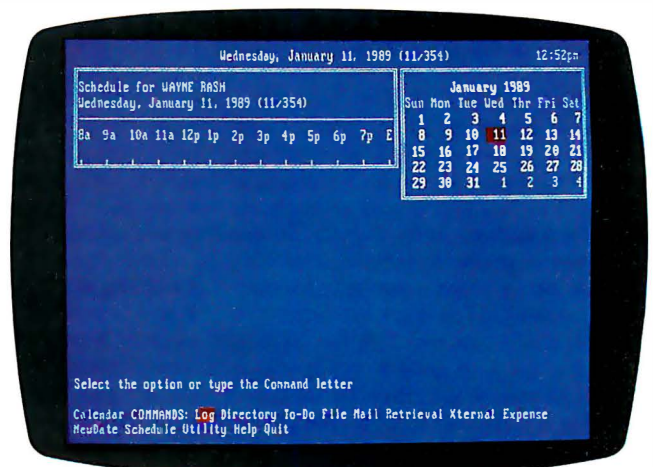

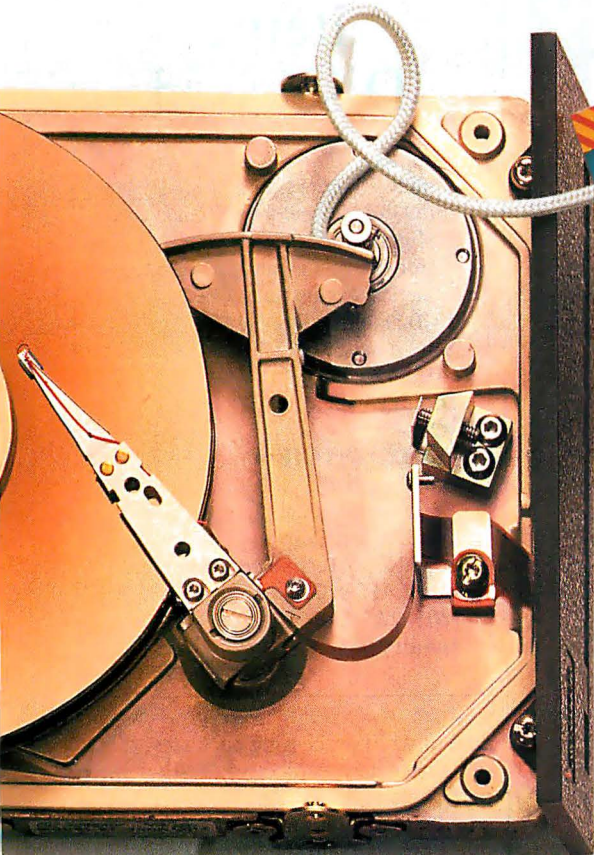

Photo 2: Higgins places the group scheduling window prominently on the screen and includes a Lotus-like menu at the bottom that gives you access to other applications.

HARD BARGAINS



THE
AFFORDABLE
FORTY



Now Seagate brings mass storage within the reach of even more people. Our new 21 megabyte ST225R and 42 megabyte ST250R represent a significant price breakthrough for half-height drives.

But low cost isn't the only benefit. The performance characteristics of these drives make them well-suited for single-user PC applications. They're faster, easier and less expensive than tape or floppies as backup devices for your existing hard drives. And with an MTBF of 35,000 hours, they feature the same high reliability that's made Seagate the first name in disc drives worldwide.

You can save not only money but time by pairing either of these drives with Seagate's own ST11R controller. With installation software preloaded on the drive, system set-up is fast and easy.

To find out more about high-quality storage solutions at surprisingly affordable prices, contact your authorized Seagate dealer. Or call Seagate at 800-468-DISC, or 408-438-6550.

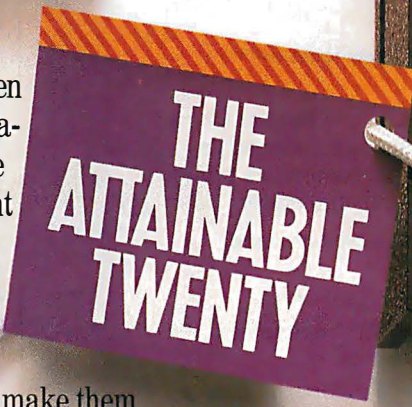

THE
ATTAINABLE
TWENTY



Seagate
The first name in disc drives

Items Discussed

Higgins

up to 20 users\$995
(\$995 additional for unlimited users)

Higgins exchange
(for external E-mail)..... \$1595

Conetic Systems, Inc.
1470 Doolittle Dr.
San Leandro, CA 94577
(415) 430-8875
Inquiry 982.

WordPerfect Office

per server.....\$495
per workstation.....\$150

WordPerfect Corp.
1555 North Technology Way
Orem, UT 84057
(801) 225-5000
Inquiry 981.

case of word processing packages, this is to some extent subjective. Still, I liked being able to load the shell once and let it stay there all day, and being able to add other programs to the menu. I also liked the similarity to WordPerfect's other products. There's no question, though, that the powerful mail capabilities of Higgins are important if you need to handle communications over a variety of systems.

Both packages are expensive compared to the normal run of single-user software. WordPerfect Office costs less for small systems, but it is priced in such a way that it costs a great deal more for really large systems, because a set amount is charged for each workstation. On really large LANs, this can be significant and has knocked Office out of the running in a couple of cases with which I'm familiar. As is often the case, you probably get what you pay for, but there is the question of whether you need all of what you're getting. ■

Wayne Rash Jr. is a consulting editor for BYTE and a member of the professional staff of American Management Systems, Inc. (Arlington, VA). He consults with the federal government on microcomputers and communications. You can reach him on BIX as "waynerash," or in the to.wayne conference.

Your questions and comments are welcome. Write to: Editor, BYTE, One Phoenix Mill Lane, Peterborough, NH 03458.

DO NOT DISTURB.

When it comes to AC power, computers need peace and quiet...

PC
MAGAZINE
EDITOR'S
CHOICE



Shield your computer and irreplaceable data from all forms of power disturbances including blackouts, brownouts, sags, surges, spikes and noise with the continuous protection provided by UPS systems from American Power.

- For file servers, CAD, UNIX, desktop publishing, and all other computer applications
- Ultra-compact desktop design for easy placement
- Models available rated from 300 to 1200 Volt-Amps for personal computers up to minicomputers
- For unattended operations, many UPS models support a direct hardware interface to operating systems such as Novell, 3-Com, Banyan, Altos, Prime, Convergent, and others. Models for international 220 V 50 Hz power are available

American Power Conversion

2 Columbia Street • P.O. Box 3723 • Peace Dale, RI 02883 • (401) 789-5735

Unix is a trademark of AT&T Bell Labs

Tandy® Computers: The broadest line of PCs in America.

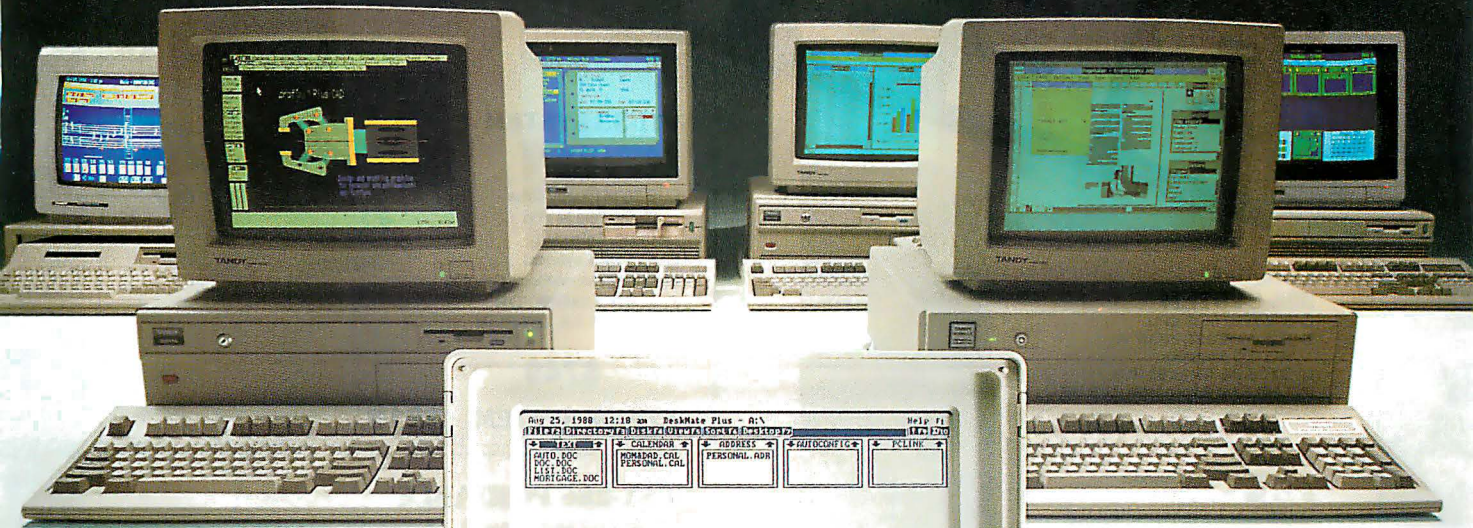

The Tandy 1400 LT



The affordable MS-DOS® based laptop computer.

Here's a laptop computer that's a true IBM® PC compatible. With a removable rechargeable battery pack built in, the Tandy 1400 LT is perfect for people on the go—like busy executives, sales personnel and journalists. Or use it like a desktop computer.

The Tandy 1400 LT features a high-resolution *backlit* liquid crystal display. The 80-character by 25-line resolution gives you the same quality of display as a full-sized monitor. And it's remarkably clear, thanks to the latest in "supertwist" LCD technology.

The 8088-equivalent microprocessor has a 7.16 MHz clock speed (vs. 4.77 MHz for most other PC-compatible portables). Standard equipment includes two 720K 3½" built-in disk drives and 768K RAM—ample memory to run today's powerful MS-DOS based programs.

The Tandy 1400 LT also includes a parallel printer adapter, RGBI color monitor output, a real-time clock and an RS-232C serial interface. You even get MS-DOS and GW-BASIC at no extra charge.

Come to your local Radio Shack and see the Tandy 1400 LT.

Send me a 1989 RSC-20 computer catalog

Mail to: Radio Shack, Dept. 89-A-668
300 One Tandy Center, Fort Worth, TX 76102

Name _____
Company _____
Address _____
City _____ State _____
ZIP _____ Phone _____

Tandy Computers: Because there is no better value.™

MS-DOS/Reg. TM Microsoft Corp. IBM/Reg. TM IBM Corp.

Radio Shack®
The Technology Store™

A DIVISION OF TANDY CORPORATION

Circle 243 on Reader Service Card

APRIL 1989 • BYTE 139

BEST

Complete 386 SYSTEM

- 80386-20 MHZ CPU
- Support 80287, 80387 & WEITEK processor
- Six 16 Bit, Two 8 Bit BUS
- 1 MB RAM (Expandable 2,4,8 MB on board), 32 Bit
- RAM Architecture (Interleaved Page Mode)
- AMI Bios
- Realtime Clock/Calendar
- 1.2 MB Floppy Drive
- Fast 1 to 1 Interleaved Hard Disk Controller
- VGA Adapter & VGA Monitor
- 66 MB Hard Drive (21 ms) (Toshiba)
- 101 Enhanced Keyboard
- Vertical Case
- MS-DOS 3.3 GW Basic
- 1 Year Warranty
- Support: NOVELL/3COM/PC NET/LanLink/OS/2

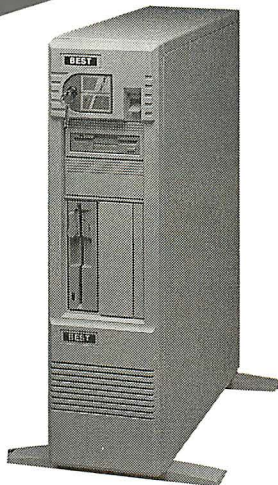

\$2990

VTI-33 SYSTEM

- 8088-2 10 MHZ
- 640 K RAM**
- 2 360K Floppy Drive
- Serial, Parallel Port
- Clock, Calendar
- AT Style Keyboard
- Build in Mono/Color Graphic
- MONO MONITOR**
- MS-DOS 3.3, GW Basic



\$749

COLOR SYSTEM \$919

BEST-286 PORTABLE

- 10 MHZ (12 MHZ Optional)
- 512 K RAM
- One 1.2 MB Floppy Drive
- 7 Expansion Slots
- 200 W DC Fan Power Supply
- 9" Dual Amber Screen
- Mono or Color Graphic Card
- 2 Serial & 1 Parallel Port
- 84 Key Soft Tough Key Board



\$1115

BEST-88 PORTABLE \$845



NEW MINI PORTABLE BEST-286 LCD

- 10 MHZ 0 WAIT (12 MHZ Option)
- 512 K RAM
- 12 M. Floppy Drive
- 20 MB Hard Disk (Seagate 125 28ms)
- 200 W DC Fan Power Supply
- Serial & Parallel
- Non-Glare LCD Screen
- Super Twist
- Built-In Back Light
- 640 x 200 Dots
- Weight 22 lbs
- Padded Soft Carry Bag
- Dimension 16" x 8" x 9"

\$1549

BEST-SUPER PORTABLE

- Gas Plasma Screen
- 640 x 400 & EGA Compatible**
- 12 MHZ 0 Wait (On Board 4MB Expandable)**
- VLSI Chip Set, AMI Bios, 31=15.6**
- 640K RAM Install
- 1.44MB Floppy Drive (3.5")
- 20MB H.D. (Seagate 125 28ms)
- Hard & Floppy Disk Controller
- 2 Serial, 1 Parallel,
- Clock, Calendar
- AT Style Key Board
- External EGA, Monitor Adaptor
- Dimension: 15" x 5 1/2" x 9"
- MS-DOS 3.3, GW Basic
- Weight: 16 lbs
- Carry Bag
- 386-20 (Option)

\$2095

286 BABY MOTHER BOARD

- 10 MHZ \$265
- 12 MHZ \$295
- Mono Monitor \$79
- Fujitsu 101 Enhance Keyboard \$45
- EGA PLUS 640 x 480 (Paradise Compatible) \$139

PORTABLE CASE

- 9" Dual Amber Monitor \$359
- 200 W Power Supply

LCD CASE

- 640 x 200 Dots \$549



VTI-55 SYSTEM

- 80286 8/12 MHZ
- Award bios
- 640K-120 ns
- 1.2 MB Floppy Drive
- 40 MB** Hard Disk Seagate ST-251 with NCL
- 2 Serial 1 Parallel
- Clock Calendar
- 101 Enhance Keyboard
- ATI EGA Wonder Card
- EGA MONITOR**
- MS-DOS 3.3, GW Basic

\$1799

MONO SYSTEM \$1499

Same Day Shipping

CALL FOR QUANTITY PRICE

BEST COMPUTER INC.

5017 Telegraph Road
Los Angeles, CA 90022

Tel: (213) 265-0900

Tech: (213) 265-0300

Fax: (213) 265-4234

Toll: **(800)634-7920**

Outside Cal.

MON - SAT 9:00 - 6:00 PACIFIC TIME

PRICE & SPEC. ARE SUBJECT TO CHANGE WITHOUT NOTICE

Circle 37 on Reader Service Card
(DEALERS: 38)

Credit Card Purchase Subject to Service Charge.





SMALLTALK CAN BE CHEAP

Smalltalk/V Mac could be a cheaper alternative to Smalltalk-80

Regular readers of this column know that I've become a convert to ParcPlace Systems' Smalltalk-80. I've been using that system for more than half a year now and I'm impressed with its abilities at ad hoc programming.

A couple of things have bothered me about Smalltalk-80, however. The first problem is its price: a budget-blowing \$995. I am trying to put together a Smalltalk course for next year, but Smalltalk-80's steep price tag is a big impediment to that. I simply can't afford to buy the 30-plus copies I'd need. A possible solution might be educational discounts and site licenses.

The second problem is Smalltalk-80's non-Mac interface, which I'll cover in more detail in a moment. Recently, another version of Smalltalk for the Mac, called Smalltalk/V Mac, from Digitalk, Inc., of Los Angeles, hit the market. Digitalk already has a PC version of Smalltalk/V available, and the new Mac version is source code-compatible with it. I've spent the last two weeks testing Smalltalk/V Mac, comparing it with Smalltalk-80, forming some early opinions about this language implementation.

First, Smalltalk/V Mac is quite a bit cheaper than Smalltalk-80 at only \$199 per copy. Second, Smalltalk/V Mac follows the Macintosh desktop interface much more closely than does Smalltalk-80. Smalltalk-80 uses an interface that's nearly identical to all the other ParcPlace Smalltalk-80 implementations on Sun workstations, among others.

Smalltalk V/Mac works and feels more like a Mac application, while



Smalltalk-80 works and feels more like a Unix workstation application. And Smalltalk/V Mac proved to be much easier to install and learn than Smalltalk-80, largely because of these interface differences.

For example, *prompters* are the methods by which Smalltalk interacts with the user or an application. Smalltalk-80 uses the traditional prompters, implemented directly in Smalltalk code as Smalltalk classes within the Smalltalk-80 environment. Smalltalk/V Mac implements prompters as Macintosh dialog boxes, preserving both the Macintosh interface and the prompter's Smalltalk functions.

In many ways, like the prompter, Smalltalk/V Mac implements standard Smalltalk features by using Macintosh pull-down menus, dialog boxes, and alert boxes. Smalltalk-80, instead, keeps the same interface across processors, so you never need to use the Macintosh menu bar unless you want to quit, invoke

a desk accessory, or jump to another application under MultiFinder.

Beyond ease-of-learning issues, these interface differences could have serious consequences for software developers. If you plan to do significant cross-machine development, the ParcPlace system is likely to be a better choice, with its consistent generic interface.

Both Smalltalk systems separate the virtual image (containing the Smalltalk-80 language and compiler, the run-time system, graphical system libraries, and program development tools) from the virtual machine (which links the operating system and hardware of a particular computer to the virtual image). ParcPlace takes this separation to its logical end by producing virtual machines that run on Sun-2, -3, and -4 workstations, Hewlett-Packard 9000s, and Apollo 3000 and 4000 workstations running Unix. ParcPlace also expects to release a DOS-based version for 80386-based sys-

continued

IEEE 488

for PC/AT/386 & PS/2

Compare the features!

IOtech Personal488

National Instruments PCIIA

\$395	\$395	IEEE 488 board with Quick BASIC & BASICA driver for PCs and compatibles
✓	✓	BASIC ON SRQ GOSUB capability
✓	✓	IEEE printer/plotter redirection utilities
✓	✓	Compatible with Windows 286 & 386
✓	✓	Compatible with IBM GPIB board
✓	N/A	DMA beyond 64K segment boundaries
✓	N/A	BASIC ON ERROR GOSUB capability
✓	N/A	Instrument control directly from DOS
✓	N/A	Borland Quattro spreadsheet support
✓	N/A	DADISP waveform spreadsheet support
✓	+\$495	Lotus 1-2-3 spreadsheet support
✓	+\$495	Lotus Symphony spreadsheet support
✓	+\$100	On-board crystal oscillator
✓	+\$50	Turbo BASIC support
✓	+\$50	True BASIC support
✓	+\$50	Microsoft C support
✓	+\$50	Microsoft Quick C support
✓	+\$50	Aztec C support
✓	+\$50	TURBO C support
✓	+\$50	Microsoft FORTRAN 4.0 support
✓	+\$50	TURBO Pascal support
✓	+\$50	8086 assembler support

\$395 \$1,935 Total

Add \$100 to each for IBM Micro Channel PS/2 support.

If you already own a National Instruments PCII or PCIIA, IBM GPIB, or any NEC 7210-based IEEE board, Driver488 from IOtech provides the software features above for only \$195. Also, our GP488B IEEE board at \$295 is an economical replacement for any of the IEEE boards listed above.

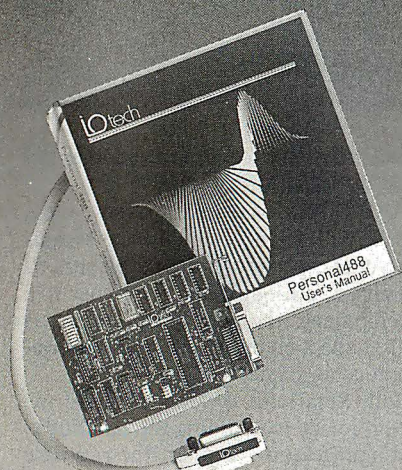

Call or send for your
FREE Technical Guide



(216) 439-4091

Telex 6502820864 • Fax (216) 439-4093

IOtech, Inc. • 25971 Cannon Road • Cleveland, Ohio 44146
 London (01734) 861237 • Paris (11348) 0178 • Milan (0214) 20360 • Brussels (02) 3848062
 Zurich (011) 219444 • Vienna (0222) 25322 • Garmisch (01) 8303333
 Linköping (0133) 110148 • Helsinki (01521) • Munich (089) 718023 • Oslo (02) 2649170
 Copenhagen (02804) 280 • Madrid (91) 4027060 • Lisbon (01) 4103620 • Seoul (02) 678 7457
 Tel Aviv (03) 491 932 • Melbourne (03) 5793622 • Toronto (416) 6740444
 Products listed are trademarks of the respective manufacturer.
 Competition based on product information available January 1, 1989.

Listing 1: Pascal code to count the frequency of alphabetic characters, from the Smalltalk/V Mac manual.

```

Program frequency;

const
    size=80;
var
    s: string(size);
    i: integer;
    c: char;
    f: array [1..26] of integer;
    k: integer;

begin
    writeln ('enter line');
    readln(s);

    for i:= 1 to 26 do
        f[i] := 0;

    for i:= 1 to size do
        begin
            c :=
                asLowerCase (s[i]);
            if isLetter(c) then
                begin
                    k := ord(c) - ord('a') + 1;
                    f[k] := f[k] + 1;
                end;
        end;

    for i := 1 to 26 do
        write (f[i], ' ');

    end.
    
```

Listing 2: Smalltalk code that performs the same operation as the code in listing 1.

```

|s c f k|

f := Array new: 26.

s := Prompter
    prompt: 'enter line'
    default: ''.

1 to: 26 do: [:i|
    f at: i put: 0].

1 to: s size do: [:i|

    c := (s at: i) asLowerCase.

    c isLetter
        ifTrue[
            k := c asciiValue - $a
                asciiValue + 1.
            f at: k pt: (f at: k) + 1
        ]
    ].
    
```

tems soon. So far, Digitalk's Smalltalk/V is available only for the Mac and the PC.

Different Approaches

Besides the interface, there are also differences in what each system provides and requires. The ParcPlace system provides many more utilities and sample objects to study, requiring six 800K-byte floppy disks and over 4 megabytes of hard disk space (once installed) to hold all the goodies. Digitalk's system needs only two 800K-byte floppies (some files are compressed with a special "compressor" application) and about 1.8 megabytes of hard disk space for installation, and lacks some of the ParcPlace utilities and samples. Both systems really need at least 2 megabytes of RAM, although the Smalltalk/V system can limp by on as little as 1 megabyte under the Finder. Smalltalk/V will also work with the Mac's RAM cache on; Smalltalk-80 will not.

Both systems are well-behaved under MultiFinder, so long as there is enough memory to go around. In my tests on an 8-megabyte color Mac II, I seldom ran into problems. Smalltalk/V Mac supports the Mac II's and Iix's math coprocessors via SANE (Standard Apple Numeric Environment) traps; Smalltalk-80 makes no mention of this support.

From my point of view, the biggest and most important difference between Smalltalk-80 and Smalltalk/V Mac is its orientation. Smalltalk-80 is presented as just one implementation of the Smalltalk-80 system that works across a variety of processors in a number of operating environments. Smalltalk/V Mac doesn't make these broad implementation claims. The Smalltalk/V package is much better geared for a quick understanding and exploration of Smalltalk than is the Smalltalk-80 package.

With Smalltalk-80, I found that three months of use had given me barely enough expertise to create simple programs, much less anything approaching a stand-alone application. In short, I was finding the learning curve pretty steep going, largely because of the way Smalltalk-80 provides its own self-contained environment. It was tough for me to intuit actions because I couldn't fall back on my knowledge of other Macintosh languages and development systems. This knowledge was quite useless as I learned Smalltalk-80.

Smalltalk/V Mac got me into the system faster (some of this learning improvement, of course, is certainly due to my accumulated Smalltalk-80 knowl-

continued

An Anti-Virus Vaccine Plus Seven RAM Resident Productivity Modules For Under \$100 Is Nothing To Sneeze At.

Today's advances in networking and connectivity mean more computers are sharing more information than ever before. That's good news!

But it also means that now, when one PC becomes infected by a virus, thousands of others across the country start sneezing almost immediately. And that's not so good.

The Cure For The Common Virus And More

For virtually any computer user concerned with protecting valuable data from infection, new MultiPlus is just what the doctor ordered.

MultiPlus combines a powerful anti-virus vaccine and seven other RAM resident productivity modules into the most comprehensive desktop management package ever offered.

Constant Data Protection

Because MultiPlus is RAM resident, you never have to worry about letting your guard down against computer mischief and crime. Anytime a virus is detected, MultiPlus automatically flashes an urgent, on-screen alarm and provides an immediate course of action to correct the problem.

With MultiPlus you'll get more value from your system, because you'll be able to take full advantage of bulletin boards and networking without worrying about your data.

The Added Plus Of A Powerful Productivity Tool

MultiPlus is more than just an anti-virus vaccine. It's a full-featured PC desktop management package, designed to enhance user productivity in business, scientific, academic, programming and home computer environments. The program's integrated modules provide:

- Full-featured word processor with a useful typewriter mode
- Database file manager that makes printing mailing labels or 3"x5" cards a snap
- Telephone message center featuring a notepad, mailbox and time/date stamp
- Five different calculators for: scientific, financial, statistical, metric-anglo conversion and programmer computations
- An infinite calendar and 24-hour appointment planner, including a holiday indicator
- PC utilities such as DOS utilities, ASCII table, system information and vaccine status
- An auto-dialer that dials phone numbers and allows you to print out phone directories.

Eight Modules One Low Price

You might easily expect to pay hundreds of dollars for anti-virus protection alone. Yet as a special introductory offer, you'll get all eight MultiPlus modules, including the potent MultiPlus vaccine for only \$99. That's a 50% savings off the regular retail price. This is a limited time offer, so call our toll-free number, or mail in the coupon below, today!



PC, XT, AT and IBM PS/2 compatible. Requires hard disk, MS-DOS 2.0 or greater and 640K. Network compatible. IBM and PS/2 are registered trademarks of International Business Machines Corporation. MultiPlus and SunFlex Software are trademarks of SunFlex Software.

**Circle 267 on Reader Service Card
(DEALERS: 268)**

**\$99 Special
Introductory Offer.**

MultiPlus™

**RAM Resident Professional Desktop
Manager And Anti-Virus Vaccine**

I Want To Take Advantage of Your
Special Introductory Offer:

Please send me _____ copies of MultiPlus at just \$99 each
plus \$3.75 shipping per order (\$12 for shipping outside USA
and Canada). Georgia residents add local sales tax.

NAME _____

ADDRESS _____

CITY _____ STATE _____

ZIP _____ PHONE _____

Form of Payment: Check Enclosed Ship C.O.D.

Call Toll Free 1-800-633-1524.

Or Mail this order from to:

SunFlex Software
1447 Peachtree Street, N.E./Suite 503/Atlanta, Georgia 30309



edge) and it was easier to figure out what to do next, since I could rely on the Macintosh menus across the top of the screen. With Smalltalk-80, I had to keep referring back to the manual, or, through trial and error, try to remember which combination of mouse clicks and Shift-Option-Command keys was needed to activate a particular pop-up menu.

Even window scrolling was easier to learn and use with Digitalk's Smalltalk/V Mac since its windows use standard Macintosh horizontal and vertical window scroll bars. In short, the Smalltalk/V Macintosh interface was easier to master than Smalltalk-80's generic workstation interface.

Perks for Programmers

The tutorial examples provided with Smalltalk/V Mac are better suited to an old procedural programmer like me. The examples often give you a side-by-side comparison of a Pascal routine next to the solution implemented in Smalltalk. This kind of side-by-side comparison is invaluable if you're learning object-oriented programming (OOP) and Smalltalk for the first time and already have

What compromises were made to Smalltalk/V to keep it so small?

programming experience with procedural languages like Pascal.

Here's a short sample taken from the Smalltalk/V Mac manual that illustrates the point nicely. One side of the page lists a simple Pascal program for counting the frequency of each alphabetic character in an input stream, as shown in listing 1. On the manual page opposite the Pascal listing is the equivalent Smalltalk program (see listing 2).

Both the Pascal and Smalltalk programs use predefined routines (Pascal used functions, Smalltalk used objects), called `asLowerCase` and `isLetter`. Both Smalltalk-80 and Smalltalk/V Mac

can use primitives similar to `asLowerCase` and `isLetter` written in other computer languages. However, any Mac Pascal development system would be hard pressed to incorporate library code written in Smalltalk.

Smalltalk-80's manual does not provide these kinds of tutorial examples. Instead, it focuses more on a pure programming-language learning approach to OOP and Smalltalk. For me, the Smalltalk/V approach was easier to follow, but it could be less so for new programmers. They could very well favor the purer environment and teaching method adopted by Smalltalk-80.

My evaluation of Smalltalk/V Mac is too preliminary to tell if it could substitute for Smalltalk-80 in my planned Smalltalk course and in my own Smalltalk exploratory programming work. I'll need to learn a lot more about the Smalltalk/V environment and figure out the compromises made to keep it so small and inexpensive. One thing's for certain: the Smalltalk/V documentation is much better suited for the course I have in mind, composed of second-, third-, and

continued

Give your software maximum protection but eliminate customers' complaints

HASP-II™

Hardware for Software Protection

HASP-II is a hardware device that connects externally into the printer port of the IBM PC/XT/AT and PS/2 families.

Special electronic circuits form a unique code allowing only your customers to operate the protected software.

Your customer can create backup copies of his programs but these copies cannot be used on a "HASPlless" computer.

Implementation is easy. You won't need the source program in order to protect your software, and yet if you have the source, we offer you the option to check for the HASP-II from within the program at any time.

We have sold tens of thousands of plugs to dozens of satisfied customers worldwide



For further information contact us at

ALADDIN
KNOWLEDGE
SYSTEMS LTD.

P.O.B.11141 Tel-Aviv 61110, Israel
Tlx.35770/1 COIN IL Ext. JBL
Tel. 972-3-226286, Fax. 972-3-243540

We've Invented the Future of Instrumentation Software . . . Twice.

With Words With Pictures

Acquisition

Integrated libraries for GPIB, RS-232, A/D-D/A-DIO plug-in cards, and modular instruments.

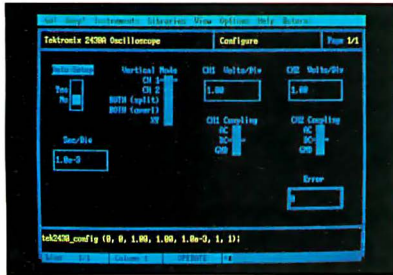

Intuitive character-based function panels that automatically generate source code.

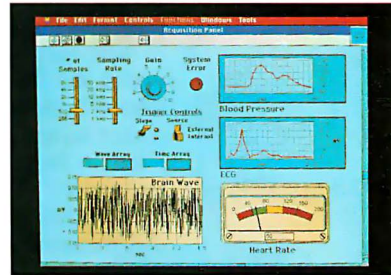

Front panel user interface with virtual instrument block diagram programming.

Analysis

Extensive libraries for data reduction, digital signal processing, and statistical analysis.

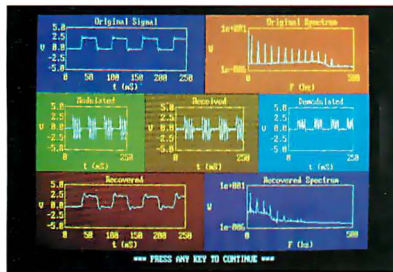

Over 100 analysis functions plus all the built-in functions of your language.

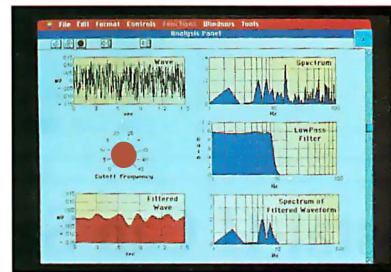

Over 250 icons for computation and analysis.

Presentation

Flexible high-performance graphics and report generation.

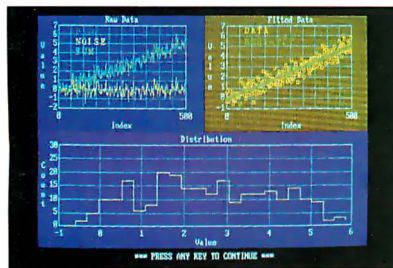

Extensive graphics support for CGA, EGA, MCGA, VGA, and Hercules.

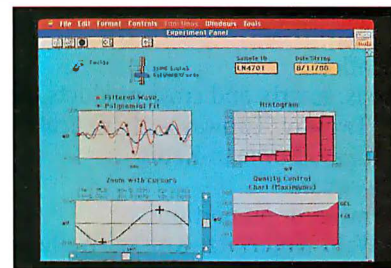

Macintosh Desktop Publishing compatibility.



LabWindows®
for the DOS-based PC and PS/2,
with Microsoft QuickBASIC or C.

12109 Technology Boulevard
Austin, Texas 78727-6204
800/531-4742 512/250-9119

LabVIEW®
for the Apple Macintosh.

National Instruments of Japan 81 (03) 788-1921 • National Instruments of France (1) 48 65 33 70 • National Instruments United Kingdom 44-01-549-3444 • ARGENTINA 541/46-5776 /0628
• AUSTRALIA 61 (3) 879-2322 • BELGIUM 02/735.21.35 • CANADA 416/890-2010-613/596-9300-(514) 747-7878-403/295-0822-(604) 988-2195 • CHILE 56 2253689 • DENMARK 45 02-251122
• FINLAND 358 90-372 144 • FRANCE 33 (1) 69077802 • HONG KONG 852 0-262707-852 0-262945 • IRELAND 353 042 72282 • ISRAEL 972 324298 • ITALY 39-2-98491071-2-3 • KOREA (02) 776-38
• MEXICO 52 660 4323 • THE NETHERLANDS 31 070-996360 • NEW ZEALAND 64 09 444-2645 • NORWAY 02-531250 • PORTUGAL 19545313 • SINGAPORE 65 29 11336
• SOUTHAFRICA 27(01 1) 787-0473 • SPAIN 34 (1) 455 81 12 • SWEDEN 4608792 11 00 • SWITZERLAND 41 6552 8949 • TAIWAN/THE REPUBLIC OF CHINA 886(02)7036280 • THAILAND 66 2349330
• UNITED KINGDOM 44 273 608 331 • WEST GERMANY 49 89 807081

Circle 317 on Reader Service Card for LabWindows.
318 for LabVIEW.

Items Discussed

MultiDisk 1.00 \$39.95
 ALSoft, Inc.
 P.O. Box 927
 Spring, TX 77383
 (713) 353-4090
Inquiry 1103.

Smalltalk-80 version 2.3\$995
 ParcPlace Systems
 2400 Geng Rd.
 Palo Alto, CA 94303
 (415) 859-1000
Inquiry 1102.

Smalltalk/V Mac version 1.00\$199
 Digitalk, Inc.
 Suite 604
 9841 Airport Blvd.
 Los Angeles, CA 90045
 (213) 645-1082
Inquiry 1101.

fourth-year undergraduates. The ParcPlace Smalltalk-80 manual would likely overwhelm them.

MultiDisk: Disk Partitioning Utility

Last month, I mentioned that I would periodically discuss some of the best utility programs that I've stumbled across. One of these handy programs is MultiDisk, a useful and inexpensive little disk partitioner from ALSoft, a company that makes several useful utilities, including Font/DA Juggler, and my favorite, MasterJuggler.

MultiDisk works like other Macintosh disk partitioning programs, allowing you to create smaller logical volumes out of large hard disks. Such partitions help you use disk space more efficiently, keep Finder operations (like file copying) speedy, and protect you from data loss due to damage to the volume directories.

But MultiDisk combines some special features that I haven't found on competing products. Among these are noncontiguous partitions (i.e., disk partitions don't need to occupy contiguous free disk space) and expandable partitions (you can make disk partitions larger

without having to erase and then re-create them).

Individual features that I've found elsewhere, but usually not all together in a single partitioner, include: partition password protection and full partition encryption, desk accessory access to partitions, and TOPS and AppleShare network accessibility of partitions. MultiDisk partitions have all the usual Finder features that are associated with normal physical volumes, so they are very easy to manage.

MultiDisk does a great job at a good price. I can't wait for ALSoft's next utility. I'm sure that once I have it, I'll find that I can't live without it. That's certainly been the case with MasterJuggler and MultiDisk. ■

Don Crabb is the director of laboratories and a senior lecturer for the computer science department at the University of Chicago. He can be reached on BIX as "decrabb."

Your questions and comments are welcome. Write to: Editor, BYTE, One Phoenix Mill Lane, Peterborough, NH 03458.

Microstat-II Can Save You Time and Money

Whether for industry, education, government, or pure research, no other statistics package can compare to Microstat-II in areas of coverage, accuracy, ease of use, and value. Just some of Microstat-II's features include

- Descriptive statistics (mean, standard deviation, variance, kurtosis, skewness, etc.)
- Regression Analysis: Simple, Multiple, Stepwise Multiple, forward and backward
- Cluster Analysis
- Canonical Correlation
- Correlation Analysis: matrix and cross products table
- ANOVA: Oneway, Twoway, Twoway with replicate
- LSD, Duncan's, Tukey, Newman-Keuls
- Crosstabs and Chi-square
- Hypothesis tests: mean or proportion
- Nonparametrics: Wald-Wolfowitz, Kruskal-Wallis, Wilcoxon, etc.
- Time Series: moving average, centered moving average, deseasonalization, exponential smoothing
- Probability Distributions: Normal, t, F, Poisson, etc.
- Frequency Distributions: value or range.
- Scatterplots (with simple regression)
- Factorials, Permutations, Combinations
- Up to eight times faster than the competition without loss of accuracy
- Online help plus easy to use keyboard or mouse input; no complex command language to learn
- Unequal cases, missing data, and aliased data, range checking
- Easy to use data entry system with file import capability
- Not copy protected
- Expanded user's manual

Requires an IBM PC, XT, AT, PS2 or compatible with 512K of memory 2 floppy disks or a hard drive. Price: \$395.00 with 30 day money back guarantee. Demo available for \$19.95. Please include \$4.00 for shipping. For information, call or write:

Orders: 1-800-952-0472
 Technical Questions: 1-317-255-6476
 FAX: 1-317-251-4604

Ecosoft Inc.
 6413 N. College Ave.
 Indianapolis, IN 46220



ECOSOFT

"I don't want to hear about trading 386 performance for portability... It's just not an option."



ZENITH INNOVATES AGAIN™

Today's leader in battery-powered portables gives you the first 386 laptop with all the options you asked for.

It's here. TurbosPort 386™. Created for one simple reason: You asked for it. Another Zenith Data Systems innovation for the way you work every day.

The lightweight TurbosPort 386 is a technological first loaded with one breakthrough after another. Like our *Page White* display, which virtually duplicates printed-page clarity. With sharp black images on a fluorescent backlit screen. And for ultimate speed, we've innovated far beyond our competition. To maximize your *Windows*-based applications in or out of the office.

TurbosPort is also the first 386 laptop to ride on Zenith's *Intelligent Power Management System*™. It gives you control of battery usage, so you'll always have the 386 performance you need. With no plugs. No cords to tie you down. You even get the desktop comfort of a detachable keyboard.

Now you no longer have to trade power for portability. And the proof is in the innovation. The Zenith Data Systems TurbosPort 386. The only portable to give you all the options of 386 desktop performance. In the office. Or anywhere.

For the name of your nearest Zenith Data Systems authorized dealer, call 1-800-553-0559.

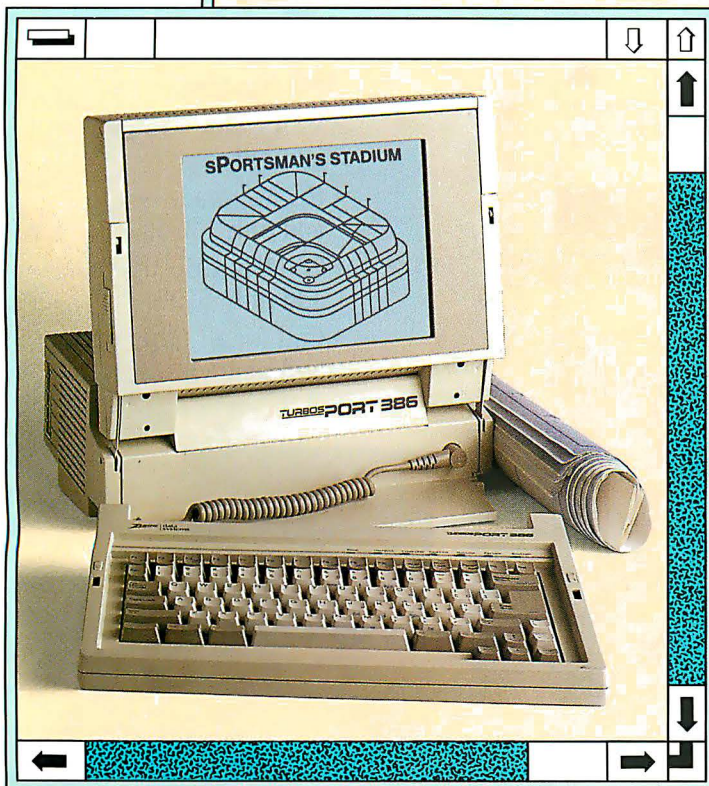

ZENITH | data systems

THE QUALITY GOES IN BEFORE THE NAME GOES ON®

Graphics simulate Microsoft® *Windows*, a product of Microsoft Corporation. Microsoft® *Windows* is included with all hard disk models of Zenith Data Systems' advanced desktop systems.

© 1989, Zenith Data Systems

Benefit from breakthrough and experience

Complete* 6, 12, 16 and 20 MHZ Systems with

SIVA Systems from VNS America Corp. delivers the uncompromising power you want, plus the hardware/software products you need. Promptly. Courteously.

Enjoy the AT®-compatibility, speed and future upgradeability you would expect from up-to-date premium quality computers. And, enjoy the fast service so many have come to appreciate from VNS America Corp.

About VNS America Corp.

VNS America Corp. and its associate companies pool their expertise and buying power to bring you premium, name brand products at breakthrough prices.

We're bold, colorful and innovative. We have to be to gain your attention in this ultra-competitive industry. But, our products and service are first rate because we need your confidence to succeed.

IBM set the standard... we're just making it affordable to thousands of companies, individuals and industry that want quality at the best prices.

TRY US
Call 1-800-252-4212

VNS America Corp.

Suite 270, 910 Boston Post Road
Marlboro, Massachusetts 01752 U.S.A.
In Massachusetts 508-481-3726
FAX: 508-481-2218

The Powerful SIVA 386 System

Standard 386 Features:

- 32-bit Intel 80386-16 CPU.
- 1MB of 32-bit RAM on board. System expandable to 16MB.
- 16/20 MHz Keyboard selectable.
- ST-251-1 Seagate 40MB Formatted 28 ms high speed, with ultra high speed Controller 1:1 interleave.
- 1.2MB High Capacity Floppy Drive.
- Super deluxe heavy duty tower case with 5 half-height drive openings.
- High-resolution 12" Non-Glare Amber Display. Tilt and Swivel base, Hercules-compatible Adapter.
- EGA Controller Standard.
- 101 Key Enhanced Keyboard, Pleasant "Tactile-Click" Feel.
- 80287/387 Math-Coprocessors optional.
- Fully compatible with virtually all XT/AT and 386 software.

\$2495

Upgrades for your 386 System:

- VGA Color Upgrade — add only \$495.
- EGA Upgrade — add only \$295.
- 20 MHz CPU Upgrade — add only \$195.
- Call for all other options and upgrades.



pricing from VNS America™ unmatched performance!

Premium Name Brand Peripherals and Software!

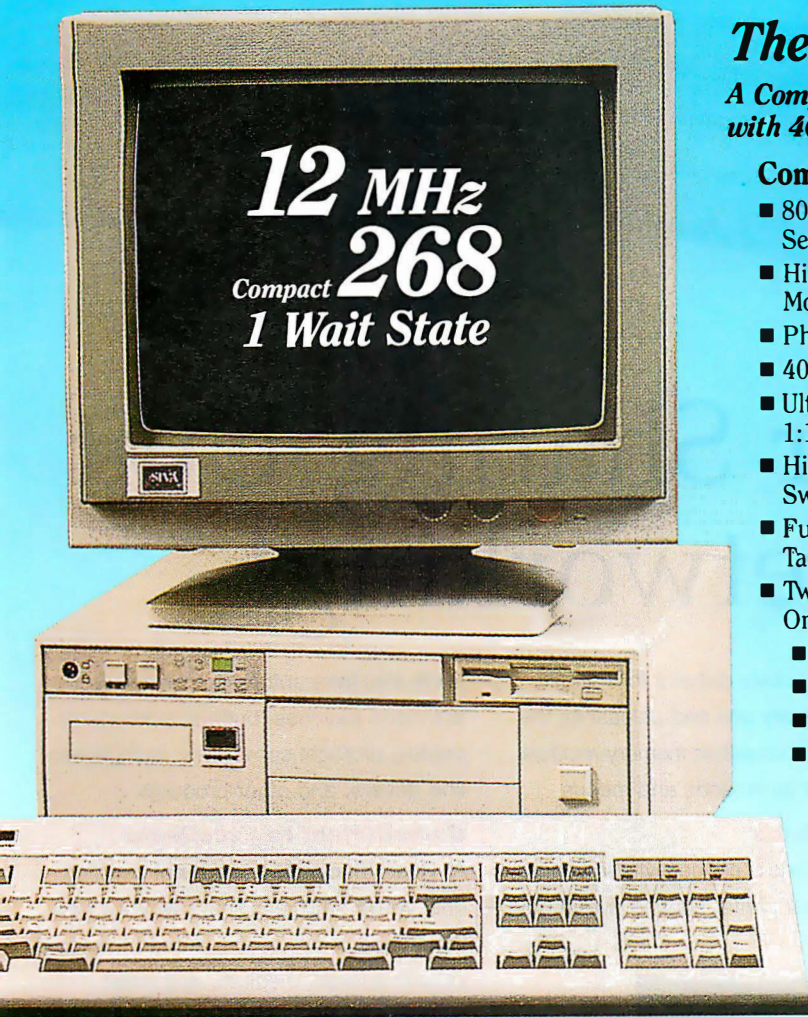

The Economical SIVA 286

**A Complete 12 MHz High-Speed SIVA 286 System
with 40MB (28MS-ST251-1) Hard Disk**

Complete System Features:

- 80286 CPU, 6/12.5 MHz Dual Speed, Keyboard Selectable
- High-Speed RAM, 512K Expandable to 4MB on the Motherboard (16MB System Total)
- Phoenix BIOS
- 40MB Hard Drive, 1.2MB Floppy Drive
- Ultra High-Speed Floppy, Hard Disk Controller 1:1 Interleave, 800KB/Sec Transfer Rate
- High Resolution 12" Amber Display with Tilt and Swivel Base, Compatible Graphics Controller
- Full 101-Key Enhanced Keyboard, Pleasant Tactile-Click Feel
- Two Serial and One Parallel Printer Ports and One Mouse Port (IBM PS/2 Compatible)
 - 3-16 Bit and 1-8 Bit Free Expansion Slots
 - Clock Calendar with 10-Year Life Battery Backup
 - 80287 Support, up to 10 MHz
- Meets FCC Requirements

\$1295

Standard System Including all Standard Features except Hard Disk \$995

Lowest Cost Compilable Upgrader

- Additional 512K Memory for \$195.
- 1.5MB Additional Memory for \$395.
- EGA Upgrade for \$295.

Nine Reasons to Call VNS America Now...

- Produced by High Technology Manufacturing Processes
- FullySurface Mounted Technology
- EGA Controller Standard
- Supports 3.5" and 5.25" Floppy Disks
- 10-Year Battery Life
- Phoenix BIOS
- No Memory Surcharge (We're not opportunists!)
- Same Day Shipment (Competitors often take 4-6 weeks.)
- 100%-Compatible with Your Budget

**Complete: includes 12 MHz high-speed SIVA 286 System with 40 MB hard disk drive, monitor and keyboard.*

™ VNS America is a trademark of VNS America Corp.

Circle 293 on Reader Service Card

VNS America Corp.

**Order Now Toll-Free
1-800-252-4212**

**Complete unit includes CPU, monitor, keyboard and 40 MB hard disk drive.*



Our Printer Sharing Unit Does Networking!

An Integrated Solution

Take our **Master Switch™**, a sophisticated sharing device, combine it with **MasterNet™** networking software for PCs, and you've got an integrated solution for printer and plotter sharing, file transfer, electronic mail, and a lot more. Of course you can also share modems, minis, and mainframes or access the network remotely. Installation and operation is very simple.

Versatile

Or you can use the Master Switch to link any computer or peripheral with a serial or parallel interface. The switch accepts over 20 commands for controlling the flow of data. It may be operated automatically, by command, or with interactive menus. Its buffer is expandable to one megabyte and holds up to 64 simultaneous jobs. The

MasterLink™ utility diskette for PCs comes with every unit and unleashes the power of the switch with its memory-resident access to the commands and menus.

Other Products

We have a full line of connectivity solutions. If you just want printer sharing, we've got

it. We also have automatic switches, code-activated switches, buffers, converters, cables, protocol converters, multiplexers, line drivers, and other products.

Commitment to Excellence

At Rose Electronics, we're not satisfied until you're satisfied. That's why we have thousands of customers around the world including large, medium, and small businesses, factories, stores, educational institutions, and Federal, state, and local governments. We back our products with full technical support, a one-year warranty, and a thirty-day money-back guarantee.



**ROSE
ELECTRONICS**

**Call now for literature or
more information.
(800) 333-9343**

Give a Rose to your computer



E-MAIL ECONOMICS

Subtle differences in E-mail services will affect your choice of the "perfect service"

The bulldozer and the backhoe are still more important to our economy than the personal computer. The VCR and video camera are still more fun. For all the hyperbole tossed around about the information age, such prosaic industrial-age inventions as cars, cement, and diet soft drinks currently have more effect on our daily lives.

There are 87 telephones, 65 cars, and 65 TVs in the country for every 100 people. Yet the percentage of PCs hovers between 10 percent and 15 percent, depending on which expert is available for a quote that afternoon.

But don't sneeze. The type of ubiquity that it took telephones 75 years to achieve, the car 70 years, and the TV 30 years will take the computer another 10 years (or less) to achieve. And one of the best measurements of this occurrence is the overwhelming growth of the E-mail industry.

Last year close to a billion electronic messages were transmitted, according to various market research groups. That's almost five times as many messages as were transmitted in 1984.

According to Mike Cavanaugh, executive director of the Washington, DC-based Electronic Mail Association, business-related use of E-mail accounts for 90 percent of all E-mail volume. E-mail's growth in the consumer area is increasing at a slower rate than for business uses, but Cavanaugh thinks this lag is only temporary.

"People who use E-mail at the office are going to want to use it at home, too. Like the telephone in its early years, it

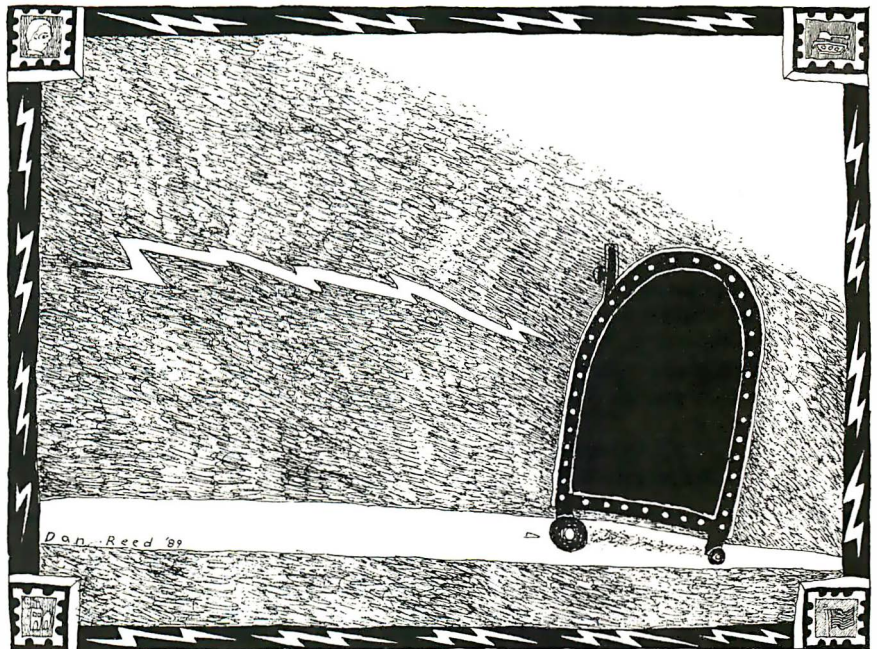

was first used primarily for business, but then people decided they wanted to use it to call their friends," Cavanaugh said. "The trouble was, not everyone had a phone in those early days. The same applies for the E-mail industry. Not everyone has an E-mail account or even a personal computer, for that matter."

For many businesses and consumers, E-mail use has become routine. Yet as the use of E-mail ramps up, so does the confusion. The variety of E-mail services available brings to mind the state of today's telephone industry. Picking the right E-mail service for your needs is no less confusing than choosing a long-distance telephone company.

When choosing an E-mail service, you should compare features such as rates, incentive services (e.g., database access), and customer support. One of the first things you'll want to check out is rate structures—not all services are created equal.

What follows is a look at the bottom

line of four popular E-mail services: CompuServe's EasyPlex, MCI Mail, Western Union's EasyLink, and BIX (see table 1).

EasyPlex

EasyPlex is CompuServe's E-mail system. CompuServe does have an alternative deluxe-type service called Executive Mail Service that offers some advantages, such as an electronic news-clipping service, but EasyPlex is more popular. And with 350,000 customers, CompuServe can accurately boast that its E-mail service has the largest number of subscribers in the world.

Charges for using EasyPlex are based on the time you spend on-line and are billed in 1-minute increments. The charges are the same as when using any of CompuServe's offerings; there is no special charge for using EasyPlex.

EasyPlex's hourly rates are in effect 24 hours a day, 365 days a week. For

continued

1200-/2400-bps access, you'll pay \$12.50 an hour; if you're still using 300-bps, it will cost you only \$6 an hour. However, CompuServe also tacks on an extra 25 cents per hour to each of the above rates for access to its system via its packet-switched network.

MCI Mail

MCI Mail is unique among these four services because its rates are not time-based; you don't pay for any of the time you spend on-line. You are charged only according to the amount of messages you send. This means you can draft letters on-line or read your E-mail on-line without being charged a penny.

MCI Mail gives its users a free-access phone line in more than 50 major metropolitan cities. If you happen to live in a city that doesn't have one of these local-access phone lines, you can access the service through an 800 number or via Tymnet. There is no charge for using the 800 number, but MCI Mail charges a fee of 25 cents per minute if you use Tymnet.

MCI Mail charges you by the "MCI ounce," which equates to 7500 characters. The first ounce costs you a flat rate of 75 cents. Every additional ounce costs \$1. So a message of 15,000 characters will cost you \$1.75. A message consisting of 7501 characters will cost you

\$1.75. If you exceed the 7500-character ounce limit by even one character, you're charged for another ounce.

Recently, MCI Mail acquired the assets of RCA Mail, an E-mail service from RCA Global Communications. Users of RCA Mail have been given the opportunity to move their E-mail box to MCI or simply drop E-mail altogether.

EasyLink

Western Union's entry into E-mail was a "do or die" kind of venture. For years, the mainstay of this company's revenue was telex transmission. Beginning in 1983, Western Union funded EasyLink with \$115 million of start-up funding, including \$45 million for advertising.

EasyLink charges \$21 per hour for 300-bps service (not so strange when you consider that Western Union telex users are used to 110-bps transfer rates). For 1200-bps access the cost is \$30 per hour. These rates apply during prime time (from 7 a.m. to 6 p.m.). The rates drop some 40 percent from midnight to 7 a.m. Like MCI Mail, EasyLink is accessed via a local phone number. If your city doesn't have an EasyLink phone number, you can use a nationwide 800 number. However, if you use this 800 number, tack an additional 30 cents per minute onto your bill.

BIX

The Byte Information Exchange (BIX) is an electronic extension of BYTE. BIX is made up of hundreds of conferences with specialized information on computer-related or general topics in each one. A few special services have been added for variety, including two daily news-wire reports, Microbytes Daily, the McGraw-Hill Executive News Service, and a real-time chat mode called Cbix. There is an E-mail capability, too, commonly referred to by its users as "BIXmail."

BIX is accessible via Tymnet. The nonpeak (7 p.m. to 6 a.m.) hourly rate is \$11. Of that \$11, the actual BIX charge is \$9; the Tymnet charge is \$2. The peak (6 a.m. to 7 p.m.) hourly rate is \$20. That breaks out to \$12 per hour for BIX and \$8 per hour for Tymnet charges. The rates listed in table 1 are for 1200-bps access. A special 2400-bps access rate tacks on an extra \$2.50 per hour during peak times and \$1.50 per hour during nonpeak times.

(For the sake of clarity, I should note that I have a professional affiliation with BIX both as a group moderator and as a contributor.)

E-Mail Benchmarks

To ferret out the bottom line for each of these systems, I've used three typical E-mail examples: a one-page memo of about 2500 characters (see table 2), a four-page letter of about 10,000 characters (see table 3), and a nine-page report of about 22,500 characters (see table 4).

I prepared each of these examples off-line and uploaded them manually at 1200 bps during normal business hours using a straight ASCII transfer implementing XON/XOFF flow control.

At first blush, the choice for an E-mail service is easy—look at the chart, and go with the lowest overall charges, right? In all four cases, this happens to be CompuServe's EasyPlex. But such reasoning is

continued

Table 1: Charges for the various services discussed. Note that the EasyLink \$25 charge is a monthly minimum usage charge. If you don't use \$25 worth of the service, you're still charged \$25, but there is no subscription fee per se. N/A denotes not applicable.

Service	Sign-up fee	Hr. rate (1200 bps, prime time)	# Subscribers
BIX	\$39 (one-time)	\$12	27,000
EasyLink	\$25 per month	\$30	200,000
EasyPlex	\$39.95 (one-time)	\$12.50	350,000
MCI Mail	\$25 per year	N/A	100,000

Table 2: A comparison of time and charges for sending messages of various lengths over the services discussed. The documents were prepared off-line and uploaded during normal business hours, at 1200 bps, using a straight ASCII transfer implementing XON/XOFF flow control. Note that MCI charges are based on document length and not on-line time. Times are in minutes:seconds.

Service	1-page memo		4-page letter		9-page report	
	Time	Cost	Time	Cost	Time	Cost
BIX	0:29	\$0.17	1:39	\$0.55	3:32	\$1.19
EasyLink	0:24	\$0.20	1:38	\$0.81	3:27	\$1.72
EasyPlex	0:41	\$0.14	1:55	\$0.40	3:35	\$0.75
MCI Mail	—	\$0.75	—	\$1.75	—	\$2.75

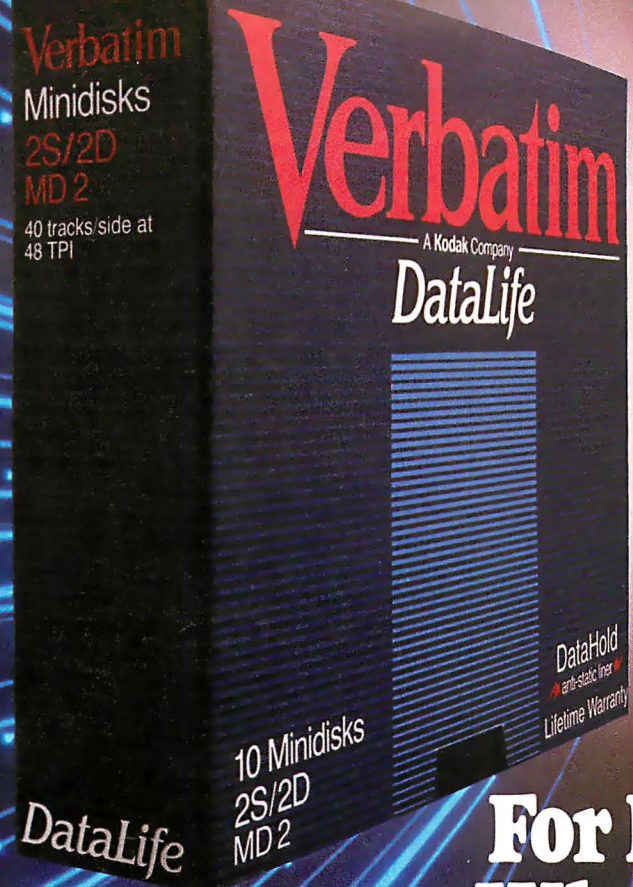

For People Who Put A Premium On Performance. And Protection.

The more invaluable your data is to you, the more you'll value Verbatim.® Because when it comes to high performance and data protection, Verbatim has the winning combination no other floppies can copy.

Consider this: Verbatim DataLife® floppies are engineered to perform an average of 50 million revolutions. That's 15 times the industry standard.

Then consider that Verbatim DataLifePlus™ and DataLife HD 5¼" disks were the first floppies to be factory formatted.

Verbatim also gives you plenty to consider when it comes to data protection. After all, nearly 50% of all computer users have lost time and money due to accidental data loss. That's why Verbatim offers advantages like DataHold™ and DataHold II

anti-static liners. So static charges are dispersed before they ever have a chance to build up.

For the world's ultimate data protection, DataLifePlus floppies have an exclusive DuPont Teflon® coating. So fingerprints and spills can be easily wiped from the recording surface.

And of course, all Verbatim floppy disks are tested to be 100% error free and are backed by a lifetime warranty.

Verbatim data cassettes and cartridges, 8", 5¼" and 3½" diskettes. For people who put a premium on performance and protection.

For more information on the full line of high-quality Verbatim products call 1-800-538-8589.

© Teflon is a DuPont registered trademark.

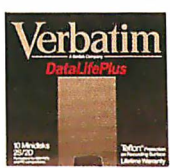
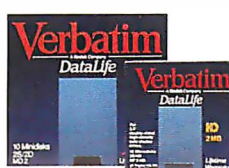

DOING MORE FOR THE DATA PROCESS™

Items Discussed

BIX

BYTE
One Phoenix Mill Lane
Peterborough, NH 03458
(800) 227-2983
(603) 924-7681
(in New Hampshire)
Inquiry 1071.

DASnet

DA Systems, Inc.
1503 East Campbell Ave.
Campbell, CA 95008
(408) 559-7434
Inquiry 1072.

EasyLink

Western Union
4230 Alpha Rd., Suite 100
Dallas, TX 75244
(800) 527-5184
Inquiry 1073.

EasyPlex

CompuServe
5000 Arlington Centre Blvd.
P.O. Box 20212
Columbus, OH 43220
(800) 848-8199
Inquiry 1074.

MCI Mail

1150 17th St.
Washington, DC 20036
(800) 444-6245
Inquiry 1075.

seductive; the choice isn't that clear-cut.

There are other factors you may want to consider. For example, there's a factor I call "on-line overhead." This is the extra time it takes to actually set up the system to input your letter, report, or memo. Using CompuServe, you have to navigate your way to the E-mail section. You can do this in two ways: by using menus or using a kind of on-line shorthand, called "go" commands.

Using the menu system on CompuServe, you might take a couple of minutes to actually reach the E-mail section; using the go commands, it takes about 30 seconds. But because CompuServe bills in 1-minute increments, you'll pay for a full minute when you use 30 seconds of on-line time. That extra minute tacks on an extra 21 cents to the actual cost of the mailing.

With the exception of MCI Mail, using each of the services mentioned here, you'll rack up some of this on-line overhead. Of course, the more familiar you are with the system, the less time you will need to set it up to input your mail. But regardless of how well you can manipulate your E-mail service, the clock is

Every copier company talks We're doing something about

Choosing a new copier isn't easy. You look at copiers, you listen to promises. It all gets very confusing.

Now, you don't have to listen to a lot of talk about promises. You can read ours. Because we put it in writing. If you try to compare it to other copier guarantees, you'll find there's no comparison. Suddenly, a difficult decision becomes a very easy choice to make.

Look at the certificate above. Nobody offers you as good a copier guarantee as Harris/3M. So, while

copier salespeople are all giving you a lot of talk, ours will give you something great to read.

Send in the coupon. Or give us a call at 1-800-TLC-COPY. (In Canada, 1-519-668-2230.) We'll send you our 8-page *Consumer Guide to Copiers*. Then, we can talk about it.

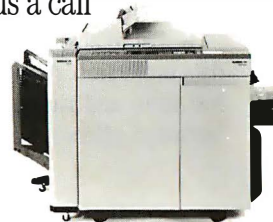

Harris/3M copiers have features for all sizes of offices. That includes the 6070. Seventy copies a minute, guaranteed.

always running. And here's where MCI Mail shines.

Using MCI Mail, you can stay on-line for as long as you wish, with no on-line overhead. This is significant when you take into account that all E-mail isn't prepared off-line, as my examples were. A simple one-page memo might take you 5 minutes to write on-line.

In addition to on-line overhead, you have to consider whether or not you want a full-service E-mail system. All these services offer extras, such as telex transmission, fax transmission, and access to special on-line information services. Though BIX does not offer telex or fax services, its on-line information service is very robust. Some of these services are priced above and beyond the on-line charges.

Then there's the question of interconnectivity, or the ability to send a message from one system to a subscriber on another system. Of the services mentioned, only MCI Mail and EasyPlex have this feature. With the other systems, you're limited to sending E-mail only to other subscribers of that service.

When choosing an E-mail service,

there is an inherent advantage to subscribing to a system that has a large number of users. The rationale is simple; the more people using the system, the more

Using
*MCI Mail, you have
no on-line overhead
to worry about.*

likely it is that you'll be able to contact whomever you need to reach.

Reaching Nonusers

In this day of global communications—and until the E-mail industry becomes truly interconnected—it seems we're stuck with having to subscribe to several E-mail services in order to receive the best coverage possible. One exception is

a service called DASnet. The folks there promise that they can "reach anyone, anywhere, with an electronic address."

DASnet operates as a kind of worldwide electronic post office for the information age. While DASnet is sometimes unreliable and has a confusing rate structure, it is the best solution to date for reaching someone via E-mail who is not a subscriber to your particular service.

While you can use statistics to help you decide which system is right for you, your best bet is to use these comparisons as a guide and then write to the E-mail companies that interest you. Ask them to send you an information package. Compare features and talk to friends who have used various E-mail services. Ultimately, you will base your decision on a combination of all these factors. ■

Brock N. Meeks is a San Francisco-based freelance writer who specializes in high technology. You can reach him on BIX as "brock."

Your questions and comments are welcome. Write to: Editor, BYTE, One Phoenix Mill Lane, Peterborough, NH 03458.

about customer satisfaction.

it.

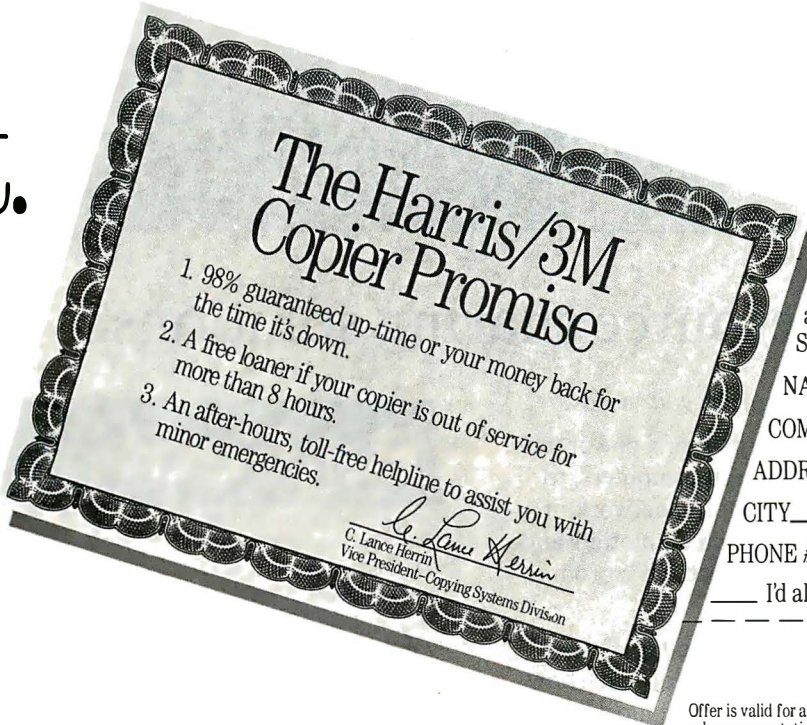

Yes, I'd like to know more about Harris/3M copiers and the Harris/3M Copier Promise.
Send to Harris/3M, P.O. Box 785, Dayton, OH 45401

NAME _____
COMPANY NAME _____
ADDRESS _____
CITY _____ STATE _____ ZIP _____
PHONE # () _____

I'd also like information on your fax machines.

MH489

HARRIS/3M

Offer is valid for a limited time and other restrictions and limitations apply; see your Harris/3M sales representative for details. ©1988 Harris/3M Document Products, Inc. Harris is a trademark of the Harris Corporation. 3M is a trademark of the 3M Company.

Because Resources Should Be Shared

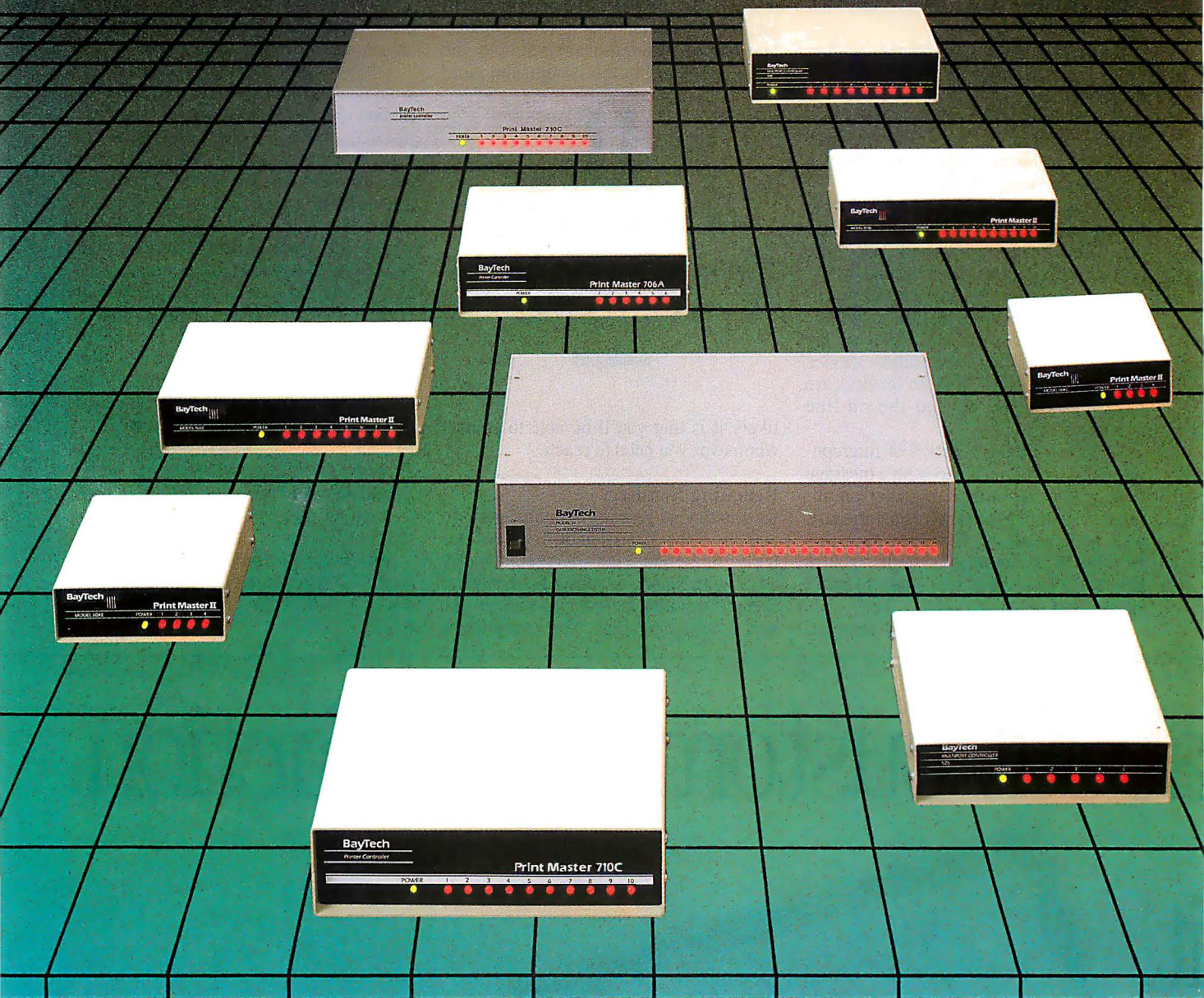

BayTech engineers resource sharing solutions.

Because we know your applications for sharing printers, plotters, modems and data are unique, BayTech has developed over 30 resource sharing products, which offer you a broad range of solutions for sharing your resources.

We realize that you shouldn't have to fit your application to the specifications of a single product. With BayTech, you select the

model that meets *your* needs.

From simply sharing one or more printers between computers, to creating a complete network of computers, printers, plotters and modems, BayTech has a product designed for you.

Call us toll-free today. Our technical support staff will show you how to make the most of your resources.



Bay Technical Associates, Inc.
Data Communications Products Division
200 N. Second Street, P.O. Box 387
Bay St. Louis, MS 39520 USA
FAX: 601-467-4551
Telex: 910-333-1618 BAYTECH
Phone: 601-467-8231 or toll-free

800-523-2702



OS/2 FOR CHEAP

Part 2 of a series showing how to put together an inexpensive OS/2 workstation

Before being interrupted by my trip to COMDEX, I was talking about building an inexpensive workstation that supports Presentation Manager (PM). So far, it consists of the following:

- a 10-MHz IBM PC AT clone with 512K bytes of RAM expandable to 1 megabyte (with a DTK motherboard and a Phoenix BIOS), a power supply, and a case
- a 3-megabyte extended-memory card (Everex RAM 3000)
- 3.5 megabytes of 256K-bit DRAMs to fill the card and the motherboard
- a Western Digital WD1003 AT-type hard/floppy disk drive controller
- a Seagate ST4096 80-megabyte hard disk drive

The total cost so far is \$2990. I've gotten these things either through a mail-order house or from my local clone boutique.

Serial Ports without 8250s

Next, I'll add printer and serial ports. It makes sense to buy one of those \$80 boards with one serial port and two parallel ports, which you'll find in mail-order ads. But you may want a board with two serial ports because you need a mouse *and* a modem, and this way you can support the mouse, modem, and parallel printer with just one slot. A separate mouse board wouldn't cost much, but it *would* gobble up a precious slot.

That's easy enough. But there's one

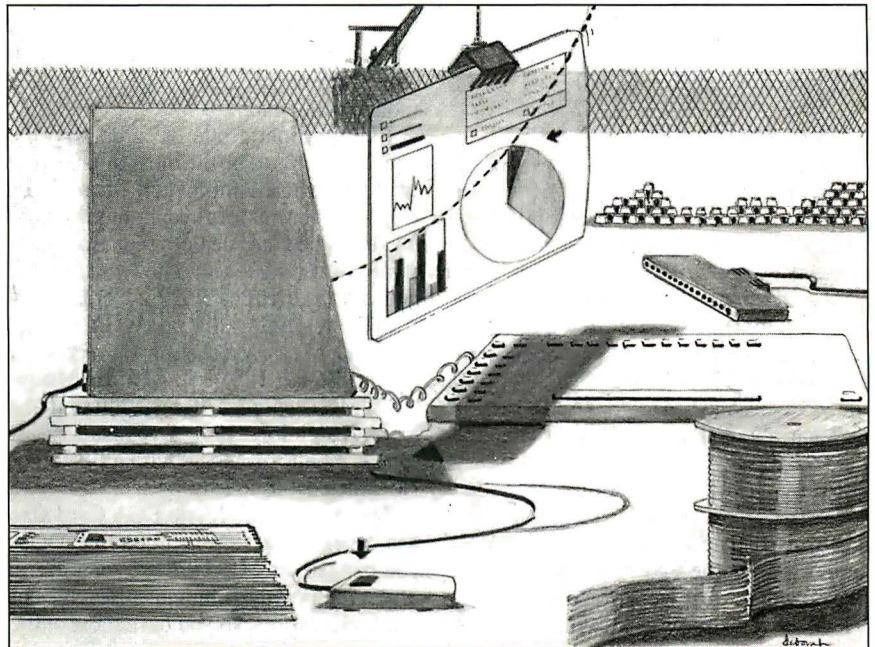

important detail to buying an OS/2-ready serial port. Serial ports and internal modems are built mainly around a single chip called a universal asynchronous receiver/transmitter. The ones seen in most serial ports are an older design called the 8250. It's perfectly good, and it can be run at speeds of up to 115,200 bps, as LapLink has ably demonstrated. A new-and-improved chip, the 16450, is now available. It, too, is a UART.

Current DOS machines may have either an 8250 or a 16450—you can't tell the difference under DOS. As internal modems are also serial devices, they too have a UART. The Hayes internal modems I've seen, for instance, use the 8250. The IBM PS/2 Micro Channel architecture-compatible internal modem uses the 16450. Again, under DOS there's effectively no difference.

Under OS/2, it's another story. OS/2 will talk only to the 16450. There are many serial/parallel add-in cards, but beware: If they have an 8250, they won't

even be recognized by OS/2.

If you already have a serial port, you can easily find out whether or not you have a 16450. First, remove the circuit board that provides the serial port function or the internal modem board. It's not hard. After that, remove the cover of your computer. With the power off, remove the screw that holds the serial board in place. Rock it back and forth gently, and the board will come out.

You won't be able to miss the identifying number—this is a large chip. The number may be surrounded by other characters (e.g., S8250N-B), but you'll easily see it. If you're worried about doing this, find someone who's been under the hood of a computer before.

If you're buying a PM-ready workstation, be sure to ask the vendor whether or not the serial ports use an 8250 or a 16450. If you can't get an answer, don't buy from that vendor.

Suppose you already have an 8250-

continued

based serial port—must it go in the trash? BYTE's hardware expert, Brett Glass, tells me that he has been able to make OS/2 happy by simply replacing the 8250 with a 16450. Many parallel/serial boards mount the 8250 with a socket, so you can replace the 8250 with a 16450 without any soldering. You can probably find a place that will sell you a 16450 in the back of this issue. Jameco Electronics is a longtime BYTE advertiser that handles chips. On the other hand, if your UART is *not* socketed and you're not comfortable with a soldering iron, perhaps it's best to buy a new board.

There are boards around that offer two serial ports and a parallel port for \$80. The total now reaches \$3070.

EGA or VGA?

The PM doesn't support CGA—well, it does, but not credibly—or Hercules graphics, so the workstation will have either EGA or VGA. There's a number of reasons to go with VGA rather than EGA, and perhaps I'll tackle them in a future column. For now, it's enough to say that the cost difference between EGA and VGA—\$150 for EGA versus \$400 for VGA—is enough to go with EGA.

What about the so-called EEGA, the "extended" EGA card with the snazzy 800- by 560-pixel resolution mode? There's no real point in buying one of these, as the nonstandard modes aren't supported by the PM anyway. But this may change. Just as Paradise, Genoa, Video Seven, and the rest have written special Windows drivers to show off their cards, perhaps we'll soon see similar drivers for the PM.

My associate, Rob Oreglia, has railed for years now against color monitors. "They're of no use to you," he argues. "Say you get a pretty color screen—how do you get a hard copy?" I can't argue with him.

The bigger problem is that color monitors are expensive. A monochrome monitor is cheap—\$70 tops via mail order, \$95 for the "paper-white" screens. EGA monitors all seem to start at \$350 and go up from there. Additionally, monochrome monitors produce nice, sharp text. So, to really make this cheap, we'll shoot for an EGA card that can support a basic monochrome TTL monitor in EGA resolution by displaying different shades. Simple, you may say—any auto-switching display card will handle that.

That's just the problem, you see. Auto-switching *kills* OS/2.

I've tried a number of video cards with OS/2—ATI's EGA Wonder, Quadram's QuadEGA+, and Paradise's EGA cards

The bigger problem is that color monitors are expensive —\$350 and up.

—and every one of them causes OS/2 to lock up when trying to boot if the card has auto-switching enabled. What's needed is a video card that boots up in EGA mode and doesn't squawk about emulating a full 256K-byte EGA on a monochrome monitor.

I've tried out a pile of cards, and the one that seems to be the most trouble-free is the Paradise AutoSwitch Mono EGA Card. Be very careful when buying this, however, because dealers seem to be unaware of its existence. They want to sell you a Paradise Basic EGA Card, or an AutoSwitch EGA 480, or a VGA Professional Card. . . . Make sure you're getting the right card by specifying Model 02-17. It lists for \$279, but I found it at a local dealer for \$199. A Samsung TTL amber monitor was \$80 with a tilt stand. Now the cost is up to \$3349.

The AutoSwitch Mono EGA Card also has other virtues. When running DOS, you can use its MEGA.EXE software to direct the board to emulate a Hercules or CGA video card, so you have most of the bases covered. I don't know of anyone at the moment that offers a similar card for VGA, but someone probably will in time.

Rodent

Some of us think mice should be in laboratories testing vaccines, but the PM needs a mouse. What's a good one? I use the Microsoft Serial Mouse. Yes, you *can* run PM without a mouse, but you have to have a head for the trivial, shall we say? You want to make drive A the default drive? Just press Control-A. Want to move from one window to another? Alt-Tab.

My advice against using the keyboard to control Windows or PM is not based on a small amount of experience; at my desk, I use a mouse. When doing PM classes, however, I often find myself having to use the keyboard, as computer rental companies are often unequal to the task of supplying a working mouse.

OS/2 claims to support several mice, and I guess it doesn't matter which one you use. I like a serial mouse for reasons I cited earlier—you save a slot. The Microsoft Serial Mouse is about \$95.

Floppy Disks Required

OS/2, being large, can't be booted from a 360K- or 720K-byte floppy disk. Since it arrives in the 1.2- or 1.44-megabyte flavor, you need a 1.2- or 1.44-megabyte drive A. OS/2 is so large that you don't really boot it upon installation—you just boot a minimum program that is smart enough to load the five disks. Then it tells you to reboot, and at that point you're in. That's part of the reason why the FORMAT /S option does not work under OS/2 1.1.

The 1.44-megabyte floppy disk seems to be the disk of choice for IBM—it was easy to get the PM on 1.44-megabyte disks weeks before it was available on 1.2-megabyte disks—so be sure that whatever machine you buy will support a 1.44-megabyte disk down the line.

Now the tally is up to \$3444, and that's final. Of course, you need to buy software, but that's for another day. Summarizing, the workstation ended up including the following:

- a 10-MHz IBM PC AT clone with 512K bytes of RAM expandable to 1 megabyte (with a DTK motherboard and a Phoenix BIOS), a power supply, and a case
- a 3-megabyte extended-memory card (Everex RAM 3000)
- 3.5 megabytes of 256K-bit DRAMs to fill the card and the motherboard
- a Western Digital WD1003 AT-type hard/floppy disk drive controller
- a Seagate ST4096 80-megabyte hard disk drive
- a Paradise AutoSwitch Mono EGA Card
- a Samsung amber TTL monitor
- an I/O card with two serial ports and one parallel port (serial ports with the 16450)
- a Microsoft Serial Mouse

Once the workstation is set up, the *real* fun begins when you start arranging files. When OS/2 installs itself on your disk, it installs itself *all over* your disk. I'll talk about the files that OS/2 drops on your machine next time. ■

Mark Minasi is a managing partner at Moulton, Minasi & Company, a Columbia, Maryland, firm specializing in technical seminars. He can be reached on BIX as "mjminasi."

Your questions and comments are welcome. Write to: Editor, BYTE, One Phoenix Mill Lane, Peterborough, NH 03458.

ZORTECH

T · E · C · H · N · O · L · O · G · Y

C DEBUGGER \$89.95

Zortech's Debugger is the most sophisticated source level debugger now available. Because it is fully compatible with Codeview you can use it to debug Zortech or Microsoft programs.

Single step through source in one window while watching the variables (inc. automatics) change value in another window. You can even alter variables dynamically while the program executes.

Much better than Codeview, and full of advanced features like dual monitor, EMS memory and Mouse support. Call for data sheet.

C VIDEO \$299.95

Learn C Now! When you buy our C Course the first lesson you learn is in economics. You will save yourself or your company hundreds of dollars in seminar tuition fees.

You get ten one hour tapes containing 36 lessons ranging from the beginners introduction through to more advanced features.

Great for learning C! Any compiler and any operating system. Complete with 365 page workbook (additional copies available at \$29.95) and free Zortech C compiler - Call for data sheet.

HELP!

TECHNICAL HOTLINES

All our products are covered by an extensive FREE technical support hotline which is open five days a week from 9.00 till 5.00 (EST)

USA HOTLINE

617-646-6703

Fax: 617-648-9340

OUTSIDE USA

44-423-501552 (England)

Fax: 44-423-530746 (England)

Discount EGGHEAD SOFTWARE

C COMPILER \$89.95

The most advanced C compiler money can buy. No junk - just pure performance.

Magazines are too embarrassed to print our optimized benchmark results - they don't want to upset the big guys!



BOTH FOR \$149.95

The 600 page manual comes with a great introductory section and lots of solid technical data and examples. Fully compatible with Codeview and the new Zortech C Debugger. You get over 400 functions and the Flash Graphics package with drivers for Hercules, CGA, EGA and VGA - the fastest graphics library available! Context Sensitive Help, an advanced editor/environment, make, touch, five memory models, linker & librarian. Library Source only \$89.95 - Call for data sheet.

ZC/TC/MSC TOOLKITS from \$49.95

Please state which compiler you have.

COMMS - \$99.95

Full Communications library with support for up to 8 ports, Xmodem, Kermit, ANSI, VT52, VT100, up to 38,400 baud, etc. 120 page manual.

BTREE - \$79.95

A database function library for C, complete with example program and over 50 functions. Easy to use with 92 page manual.

WINDOWS - \$69.95

Enhance your application with easy to use multiple text windows. Full demo program including 90 page manual.

PROSCREEN - \$69.95

Generates C source code for your application from screens that you draw. Too many features to list.

HOTKEY - \$69.95

Write memory resident applications with this TSR function toolkit. Includes example progs.

SUPERTEXT - \$49.95

WordStar compatible wordprocessor with full source code and 256 page manual. Over 150 functions.

CHESS - \$49.95

Learn to write Chess games with this toolkit (contains full source). Also includes Backgammon and 150 page manual.

Please request full data sheets.



C++ COMPILER \$149.95

This is the world's only true C++ compiler for MS-DOS machines - there is no choice. Not to be confused with 'translators' which are slow, expensive, inefficient and not real C++ compilers.

More people use Zortech's C++ than any other C++ on any operating system. Zortech strives to ensure full compatibility with AT&T C++.

Zortech C++ contains all the features of Zortech C including the C compiler itself at no extra cost. Everything is in one neat package. Compatible with Codeview and the new Zortech Debugger. C++ Library Source only \$149.95 - Call for data sheet.



BYTE 1988 WINNER

C++ TOOLS \$99.95

Zortech's toolkit of base C++ classes covering a wide range of common programming tasks such as bit vectors, singly and doubly linked lists, dynamic and virtual arrays, binary search tree, hash table, BCD maths, time/date/clock, directory lists, filenames, interrupt and critical error handlers, string editing, text windows and editing.

The 450 page manual also acts as a C++ tutorial which introduces the C programmer to the world of C++. Call for data sheet.



- C Primer (Sams) - \$23.95
- Advanced C Primer (Sams) - \$23.95
- C++ (Stroustrup) - \$29.95
- Oops & C++ (Wiener) - \$27.95

BOOKS

ORDER HOTLINE 1-800-848-8408

VISA/MC/COD

Prices do not include shipping

Circle 308 on Reader Service Card

Zortech, Inc., 1165 Massachusetts Avenue, Arlington, MA 02174. (617) 646-6703. Fax: (617)-643-7969.

Outside USA: Zortech Ltd., 106-108 Powis Street, London SE18 6LU, England. (44-1)-316 7777. Fax: (44-1)-316 4138.

Take any 3 books for only \$1⁰⁰ each

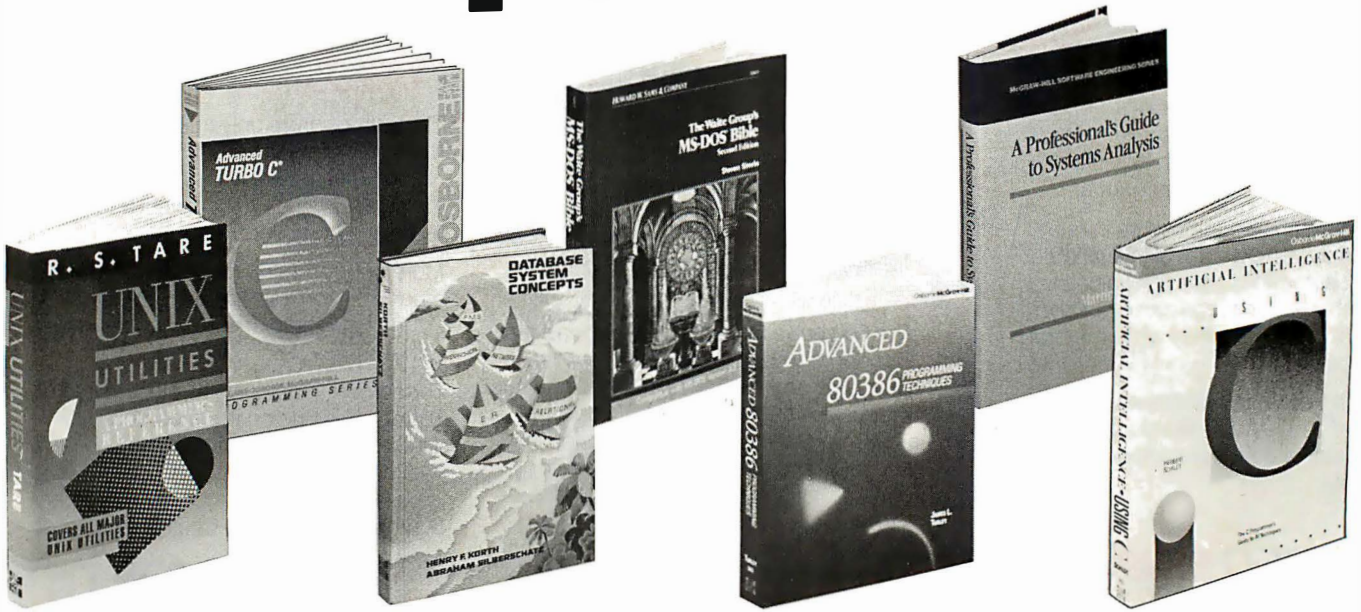

when you join BYTE Book Club[®] VALUES UP TO \$138.40

OS/2 PROGRAMMER'S GUIDE. By E. Iacobucci. 1100 pp., illus. softbound. "Byte" magazine called it "a necessity." This giant reference explains all the basic functions you'll need, with emphasis on such new or different functions as multitasking and memory management.
881300-X Pub. Pr., \$24.95

UNIX UTILITIES. By R.S. Tare. 352 pp., illus., softbound. This practical manual shows how to make the best use of UNIX utilities. It covers more utilities than any other book of its kind and provides numerous examples of real applications.
628/84X Pub. Pr., \$27.95

dBASE POWER: Building and Using Programming Tools. By P.L. Olympia, R. R. Freeland, and R. Wallin. 380 pp., illus., softbound. This practical guide shows the experienced dBASE III or dBASE III PLUS programmer how to use to the fullest such features as RUN and CALL/LOAD, as well as how to write C and assembly language programs that perform dBASE functions for you.
584696-9 Pub. Pr., \$29.95

A PROFESSIONAL'S GUIDE TO SYSTEMS ANALYSIS. By M.E. Modell. 307 pp., illus. Detailed coverage of what you need to know — what questions to ask, how to conduct a cost-benefit analysis, how to document and validate your findings — to design the best systems for your user's needs.
426/325 Pub. Pr., \$34.95

ADVANCED GRAPHICS IN C: Programming and Techniques. By N. Johnson. 430 pp., illus., softbound. Now C programmers can write crisp graphics programs for the IBM-PC using the IBM EGA (Enhanced Graphics Adaptor) or the AT&T Image Capture Board (ICB). Includes GRAPHIQ, a complete C graphics toolkit.
881257-7 Pub. Pr., \$22.95

A COMPREHENSIVE GUIDE TO AI AND EXPERT SYSTEMS: Turbo Pascal Edition. By R.I. Levine, D.E. Drang, and B. Edelson. 256 pp., 99 illus. A must for everyone who wants to understand and utilize artificial intelligence for commercial, military, scientific, or educational applications. It's all in clear, simple language with many illustrations and sample programs.
374/708 Pub. Pr., \$24.95

IBM® PC AND MACINTOSH® NETWORKING. By S.L. Michel. 296 pp., illus., softbound. This state-of-the-art guide shows how to painlessly network your PC's and MAC's so that they share files, storage, and printers. Full descriptions of TOPS™ and AppleShare™ allow you to choose the solution that's right for you and implement it for greatest advantage.
584658-6 Pub. Pr., \$21.95

ADVANCED 80386 PROGRAMMING TECHNIQUES. By J.L. Turley. 509 pp., illus., softbound. Offering advanced techniques for serious programmers, this hands-on-guide covers advanced memory segmentation, the internal four-level protection hierarchy, multitasking, demand paging, system security, 8086/80186/80286 emulation, and intertask communication.
881342-5 Pub. Pr., \$22.95

THE WAITE GROUP'S MS-DOS BIBLE, Second Ed. By S. Simrin. 522 pp., illus., softbound. Shows you how to start up your system, create and manage files, customize your keyboard, and become proficient in such advanced MS-DOS features as LINK, DEBUG, TSR programming, and device drivers.
584702-7 Pub. Pr., \$22.95

ADVANCED TURBO C.® By H. Schildt. 397 pp., illus., softbound. Complete Turbo C mastery can be yours—from stacks, queues, linked lists and binary trees, to operating system interfacing, porting, debugging, and much more. Fully explains how to get the most from the power and speed of Turbo C.
881280-1 Pub. Pr., \$22.95

DATABASE SYSTEM CONCEPTS. By H. F. Korth and A. Silberschatz. 546 pp., illus. From fundamental concepts to advanced problem solving, this book provides a clear understanding of the design and use of database systems. Also demonstrates the best ways to protect data from unauthorized access and malicious or accidental alteration or destruction.
447/527 Pub. Pr., \$42.95

ARTIFICIAL INTELLIGENCE USING C: The C Programmer's Guide to AI Techniques. By H. Schildt. 412 pp., 37 illus., softbound. This hands-on guide shows you how to create your own AI applications and systems using C. After an introductory overview it provides coverage of expert systems, logic, natural language processing, machine learning, pattern recognition, and more, with ready-to-run programs illustrating each topic.
881255-0 Pub. Pr., \$21.95

PROGRAMMING USING THE C LANGUAGE. By R.C. Hutchison and S.B. Just. 519 pp., illus. Whether you want to understand programs in C written by others, or write better C programs of your own, this practical, authoritative book gives you the tools and guidance you need. Coverage includes program organization, sorting algorithms, recursion, linked lists, and more — with many sample programs.
315/418 Pub. Pr., \$29.95

HARD DISK MANAGEMENT with MS-DOS and PC-DOS. By D. Gookin and A. Townsend. 307 pp., illus. Shows you how to make the best use of your hard disk for all types of programs, with an emphasis on organization, data security, and enhancing performance. Easy enough for novices, yet sophisticated enough for power users, it's packed with helpful hints, proven shortcuts, and clear explanations.
583954-7 Pub. Pr., \$27.95

TRICKS OF THE UNIX MASTERS. By R.G. Sage. pp. illus. Many of UNIX's most interesting features have virtually been kept secret from users — until now! This master guide goes beyond the basics to show you the shortcuts, tools, tips, and tricks it could take years to discover on your own.
584637-3 Pub. Pr., \$22.95

BYTE BOOK CLUB®

Membership Order Card

Please enroll me as a member and send me the three choices I have listed below. Bill me only \$3.00, plus local tax, postage and handling. I agree to purchase a minimum of two additional books during my first year as outlined under the Club plan described in this ad. Membership in the club is cancellable by me any time after the two book purchase requirement has been fulfilled. A shipping and handling charge is added to all shipments.

Indicate below by number the books you want. A few expensive books (noted in the descriptions) count as more than one choice.

<input type="text"/>	<input type="text"/>	<input type="text"/>
----------------------	----------------------	----------------------

Signature _____

Name _____

Address/Apt.# _____

City, State, Zip _____

Corporate Affiliation _____

This order subject to acceptance by McGraw-Hill. All prices subject to change without notice. Offer good only to new members. Foreign member acceptance subject to special conditions.

BYTE BOOK CLUB®

Membership Order Card

Please enroll me as a member and send me the three choices I have listed below. Bill me only \$3.00, plus local tax, postage and handling. I agree to purchase a minimum of two additional books during my first year as outlined under the Club plan described in this ad. Membership in the club is cancellable by me any time after the two book purchase requirement has been fulfilled. A shipping and handling charge is added to all shipments.

Indicate below by number the books you want. A few expensive books (noted in the descriptions) count as more than one choice.

<input type="text"/>	<input type="text"/>	<input type="text"/>
----------------------	----------------------	----------------------

Signature _____

Name _____

Address/Apt.# _____

City, State, Zip _____

Corporate Affiliation _____

This order subject to acceptance by McGraw-Hill. All prices subject to change without notice. Offer good only to new members. Foreign member acceptance subject to special conditions.

**BUSINESS REPLY MAIL**

FIRST CLASS MAIL PERMIT NO. 42 HIGHTSTOWN, NJ

POSTAGE WILL BE PAID BY ADDRESSEE

McGraw-Hill Book Clubs
P.O. Box 582
Hightstown, NJ 08520-9959

**BUSINESS REPLY MAIL**

FIRST CLASS MAIL PERMIT NO. 42 HIGHTSTOWN, NJ

POSTAGE WILL BE PAID BY ADDRESSEE

McGraw-Hill Book Clubs
P.O. Box 582
Hightstown, NJ 08520-9959

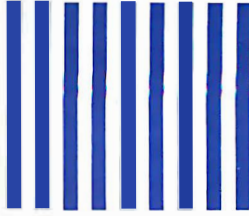
NO POSTAGE
NECESSARY
IF MAILED
IN THE
UNITED STATESNO POSTAGE
NECESSARY
IF MAILED
IN THE
UNITED STATES

SADT: Structured Analysis and Design Technique. By D. Marca and C. McGowan.
402/353 Pub. Pr., \$49.95
(Counts as 2 of your 3 books)

PROGRAMMING WITH TURBO PASCAL. By D. Carroll
852908-5 Pub. Pr., \$39.95

HIGH-SPEED ANIMATION & SIMULATION FOR MICROCOMPUTERS. By L. Adams
583855-9 IPub. Pr., \$20.95

PROGRAM TRANSLATION FUNDAMENTALS: Methods and Issues. By P. Calingaert.
584589-X Pub. Pr., \$36.95

PRINCIPLES OF PARALLEL AND MULTI-PROCESSING. By G.R. Desrochers.
165/793 Pub. Pr., \$53.50
(Counts as 2 of your 3 books)

UNDERSTANDING & USING dBASE III® PLUS. By R. Krumm.
583940-7 Pub. Pr., \$22.95

32-BIT MICROPROCESSORS. Edited by H.J. Mitchell.
425/85X Pub. Pr., \$48.50

THE DATABASE EXPERTS' GUIDE TO DATABASE 2. By B. Larson.
232/679 Pub. Pr., \$24.95

NETWORKING SOFTWARE. By C. B. Ungaro.
606969-9 Pub. Pr., \$39.95

THE DATABASE EXPERT'S GUIDE TO SQL. By F. Lusardi
390/061 Pub. Pr., \$39.95

PRINCIPLES OF ARTIFICIAL INTELLIGENCE AND EXPERT SYSTEMS DEVELOPMENT. By D.W. Rolston
536/147 Pub. Pr., \$44.95

HOW TO WRITE COMPUTER DOCUMENTATION FOR USERS, 2nd Ed. By S.J. Grimm
583783-8 Pub. Pr., \$29.95

DATA STRUCTURES USING PASCAL, 2nd Ed. By A. M. Tenenbaum & M. J. Augenstein
583738-2 Pub. Pr., \$46.00

MICROCOMPUTER LANS: Network Design and Implementation. By M.F. Hordeski
584580-6 Pub. Pr., \$28.95

OPERATING SYSTEMS. By M. Milenkovic
419/205 Pub. Pr., \$40.95

CIARCIA'S CIRCUIT CELLAR, Vol. VI. By S. Ciarcia.
109/680 Pub. Pr., \$23.95

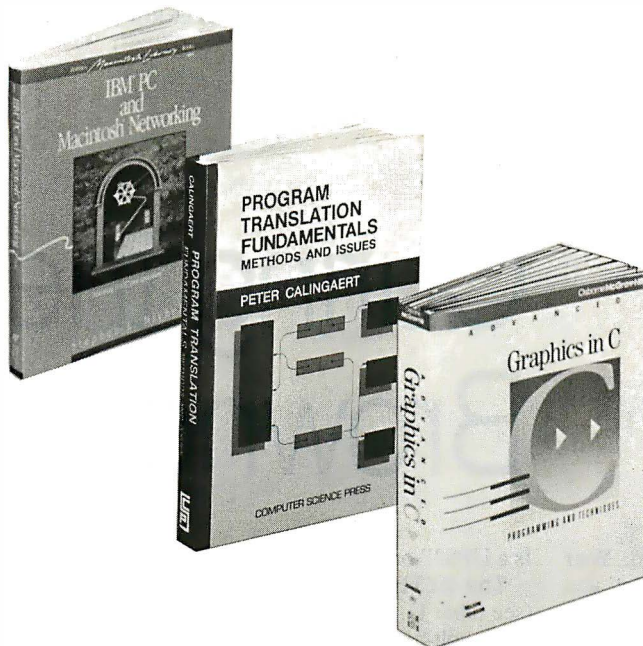

Any 3 books for \$1.00 each... if you join now and agree to purchase two more books — at handsome discounts — during your first year of membership.

MASTERING TURBO PASCAL 4.0, 2nd Ed. By T. Swan.
584762-0 Pub. Pr., \$22.95

DESIGNING USER INTERFACES FOR SOFTWARE. By J.S. Dumas.
584641-1 Pub. Pr., \$31.00

68000 ASSEMBLY LANGUAGE PROGRAMMING, 2nd Ed. By L. Leventhal; D. Hawkins; G. Kane & W. Cramer
583817-6 Pub. Pr., \$28.95

ADVANCED COBOL, 2nd Ed. By A. S. Philippakis and L. J. Kazmier.
498/13X Pub. Pr., \$37.95

HARD DISK MANAGEMENT IN THE PC & MS-DOS ENVIRONMENT. By T. Sheldon
565/562 Pub. Pr., \$24.95

FILE ORGANIZATION FOR DATABASE DESIGN. By G. Wiederhold.
701/334 Pub. Pr., \$40.95

USING TURBO C. By H. Schildt
881279-8 Pub. Pr., \$19.95

COMPUTER ORGANIZATION. By M. Andrews.
584588-1 Pub. Pr., \$39.95

PROGRAMMING IN C, Revised Ed. By S.G. Kochan.
584701-9 Pub. Pr., \$24.95

CIARCIA'S CIRCUIT CELLAR, Volume V. By S. Ciarcia
109/672 Pub. Pr., \$24.95

HANDBOOK OF SOFTWARE MAINTENANCE. By G. Parikh
583639-4 Pub. Pr., \$35.95

THE C PRIMER, 2nd Ed. By L. Hancock & M. Krieger
259/95X Pub. Pr., \$24.95

DATA TYPES AND DATA STRUCTURES. By J. J. Martin
583689-0 Pub. Pr., \$45.00

TROUBLESHOOTING AND REPAIRING THE NEW PERSONAL COMPUTERS. By A. Margolis.
583871-0 Pub. Pr., \$17.95

More Books to Choose from

123: THE COMPLETE REFERENCE. By M. Campbell.
881005-1 Pub. Pr., \$22.95

QUICK C PROGRAMMING FOR THE IBM. By C. Townsend.
584659-4 Pub. Pr., \$22.95

HOW TO BE A SUCCESSFUL COMPUTER CONSULTANT. By A. R. Simon
572/968 Pub. Pr., \$24.95

MS-DOS BATCH FILE PROGRAMMING ... including OS/2. By R. Richardson.
584710-8 Pub. Pr., \$17.95

INTRODUCING PC-DOS AND MS-DOS: A GUIDE FOR BEGINNING & ADVANCED USERS. By T. Sheldon
565/597 Pub. Pr., \$24.95

APPLYING EXPERT SYSTEMS IN BUSINESS. By D. N. Chorafas
108/803 Pub. Pr., \$33.95

STRUCTURED COBOL: A STEP BY STEP APPROACH. By C.R. Litecky and G.B. Davis.
157/88X Pub. Pr., \$30.95

TELECOMMUNICATIONS AND DATA COMMUNICATIONS FACTBOOK. By J. Abbatiello and R. Sarch
606965-6 Pub. Pr., \$44.95

DESIGN OF DISTRIBUTED OPERATING SYSTEMS. By P. J. Fortier
216/215 Pub. Pr., \$44.95

WORDPERFECT®: THE COMPLETE REFERENCE. By K. Acerson.
881312-3 Pub. Pr., \$27.95

PROGRAMMER'S CHALLENGE: 50 Challenging Problems to Test Your Programming Skills. By S. Chen.
583883-4 Pub. Pr., \$29.95

Here's how Byte Book Club® works to serve you:

- **Important information ... we make it easy to get!** Today, professionals who perform best are those who are best informed. For reliable, hands-on information, turn to the Byte Book Club. Every 3 or 4 weeks (12-15 times a year), members receive the Club Bulletin offering more than 30 books — the best, newest, most important books from all publishers.
- **Dependable service ... we're here to help!** Whether you want information about a book or have a question about your membership, just call us toll-free or drop us a line. To get only the books you want, make your choice on the Reply Card and return it by the date specified. If you want the Main Selection, do nothing — it will be sent to you automatically. (A small shipping and handling charge is added to each shipment.)
- **Club convenience ... we do the work!** You get a wide choice of books that

simply cannot be matched by any bookstore. And all your books are conveniently delivered right to your door. You also get 10 full days to decide whether you want the Main Selection. (If the Club Bulletin ever comes late and you receive a Main Selection you don't want, return it for credit at our expense.)

- **Substantial savings ... and a bonus program too!** You enjoy substantial discounts — up to 40%! — on every book you buy. Plus, you're automatically eligible for our Bonus Book Plan which allows you savings up to 70% on a wide selection of books.
- **Easy membership terms ... it's worthwhile to belong!** Your only obligation is to purchase 2 more books — at handsome discounts — during the next 12 months, after which you enjoy the benefits of membership with no further obligation. You or the Club may cancel membership anytime thereafter.

Fill out the card and mail today! If the card is missing, write to:

BYTE BOOK CLUB®, P.O. Box 582, Hightstown, New Jersey 08520-9959
For faster service in enrolling, call 1-800-2-MCGRAW



Curing the Brownout Blues

Ka-thunk. The lights dim. Your heart stops. For a moment, you are frozen. Time seems to stand still. Then you hear the familiar sound of your computer booting. To you, it sounds remarkably like a toilet flushing your precious data down the drain. If only you would learn to save your work more often. If only . . .

All of us who use computers live on the edge. Yes, you have heard all the adages about saving your work and backing up everything, but do you really do it as often as you should? At some point, you enter the danger zone, where one good lull in the power line could cost you greatly in terms of lost data. Not even an uninterruptible power system (UPS) can promise absolute protection, but it can offer some peace of mind to those who fear the dreaded power brownout.

Consider the following disquieting information. In 1972, 1975, and 1983, IBM published studies on utility power across the U.S. (the 1983 survey also included Japan and Europe), recording incidents—out-of-specification fluctuations above and below line voltage. Though frequency of fluctuations depends heavily on your location, on average, the frequency of such incidents rose from 12 percent to 27.3 percent, and the number of outages increased from 5 percent to 15 percent.

In its *Gold Book*, the IEEE recommends that computer equipment be designed to operate within a steady-state window 6 percent above and 13 percent below normal line voltage. Most computer equipment available today complies. But the largest group of incidents recorded by the IBM study covered sags of 20 percent; the second largest group (and growing) included sags of 30 percent (it tied with total blackouts). More than half of all incidents lasted less than 6 seconds. If your work is intimately tied to your microcomputer, you would be wise to purchase a UPS. (For a primer on UPS technology, see the text box “What

Is a UPS?” on page 168.)

The BYTE Lab looked at 12 UPSes (see table 1). Each unit is rated at under 1500 volt-amperes (VA)—designed primarily to support microcomputers or networks. We were looking for units to provide reliable backup power; we did not test for overvoltage protection. While surge and spike suppression are important to line quality and are often offered as enhancements, they don't fall within the traditional domain of the UPS.

UPS Testing

The words behind the UPS acronym suggest that such a product provides power that is, within reasonable limits, uninterruptible. Testing a UPS means determining just how invulnerable to interruption it really is—feeding it less-than-ideal power and looking at how much of the disturbance the unit passes on to your computer.

To provide power disturbances, we used a Variac rated for 120-/240-volt inputs, a 9-A load, and output voltages ranging from 0 V to 280 V. A Variac is a variable autotransformer, a device that let us convert fixed line voltages (from the wall socket) to any 60-Hz voltage within the given output range. The Variac let us do simple but realistic and repeatable simulations of low line voltages.

We monitored UPS inputs and outputs using two line monitors to measure root-mean-square voltage and an oscilloscope to capture actual voltage waveforms. The first line monitor is a BMI GS-3, a low-load instrument that gives a constant reading of RMS voltage when connected to a power outlet. The unit gives reliable readings for sine waves only, so we used it to test only inputs.

To monitor UPS outputs, we used a BMI 2400 Power Scope, a similar but more sophisticated device that gives true RMS readings, even for nonsinusoidal waves. For waveform acquisition, peak voltage measurements, and timings, we used a Hewlett-Packard Model 16530

digitizing oscilloscope.

A line-switching device developed by Emerson rounded out our test equipment. The Emerson box uses a solid-state switch to toggle its output between direct connection to line voltages and connection to line voltages through the Variac. The output is normally connected directly to the power line. The Variac input acts as a variable voltage source or, when set to other than line voltage, as a disturbance input.

When the switching device is activated, the solid-state switch connects the output to the Variac (the disturbance input) for a short time, then switches back to normal line voltage, without disturbing the phase. The test instrument also generates a trigger signal so that we could monitor each disturbance with the oscilloscope. Timing controls let us choose both the duration (from 0.2 millisecond to 683 ms) and the start time (as a position on the sine wave) of the disturbance; adjusting the Variac let us select its magnitude. With the Emerson unit, we were able to replicate most common line faults in both size and duration.

Table 2 shows our results. It includes a single figure for cutoff voltage and restart voltage, and three figures for output voltage. The cutoff voltage represents the input level at which the UPS kicks in—where it generates an input fault alarm and, if necessary, switches to backup power. We measured the cutoff voltage by connecting the UPS being tested directly to the Variac and lowering the voltage until the test unit responded. After recording this cutoff voltage reading, we turned up the Variac until the test UPS switched back on; the turn-on level is the restart voltage.

As a caveat, these two figures can be affected by the impedance of the Variac and the nonlinear current draw of the units being tested. Each UPS was loaded with an IBM PS/2 Model 80 and a monitor (168 VA) connected to its output.

The three output voltage numbers rep-

Twelve UPSes that can help you sleep better at night

Steve Apiki, Stanford Diehl, and Rick Grehan

resent the normal, backup, and minimum steady-state voltages present at the UPS output. To perform the normal output test, we plugged the UPS into the line socket, loaded it with the Model 80, and determined RMS output. We also used the oscilloscope to get a picture of the normal output waveform.

To find the backup voltage, we disconnected the UPS from the line and again measured the output. Minimum output voltage is the RMS reading for the unit just before switching to backup, if the unit is a standby power system (SPS), or the smallest voltage reached while the input is reduced to zero. To read this, we wired the test UPS to the Variac and turned down the input voltage, recording the minimum output value.

We used the oscilloscope to measure the effect of four undervoltage line disturbances that were generated by the Emerson box. The voltage levels were set at minus 30 percent from nominal line; we used $\frac{1}{8}$ -, $\frac{1}{4}$ -, $\frac{1}{2}$ -, and one-cycle durations. Each distur-

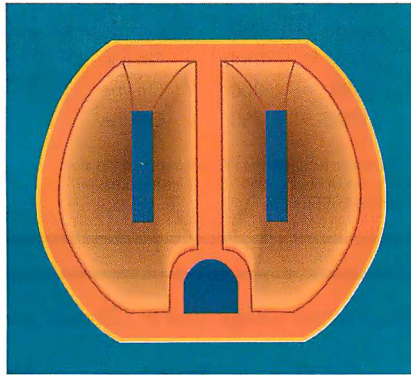

bance began at a positive slope zero crossing. We made qualitative observations and measured peak voltages from the scope trace. Again, we loaded the test units with a PS/2 Model 80.

To determine transfer times and their sensitivity to different loads, we sent one-cycle near-blackout voltages (minus 75 percent) to each of the six SPSes. Using the storage oscilloscope, we captured the resulting waveforms and measured the transfer times (see photo 1). We performed the test twice, once with a small load (the Model 80) on the UPS and once with a moderate load (420 VA).

We supplemented the disturbance tests with a measurement of holdup time (how long a UPS/SPS can provide usable power when disconnected from the wall). Because the holdup time's load response can be nonlinear, we used loads of three sizes. The small and moderate loads corresponded to those used in the transfer-time test.

We also used a large (672 VA) load to put a realistic

continued

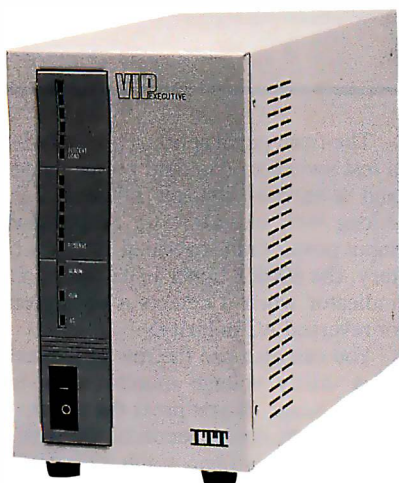

Three of the best:
ITT PowerSystems' VIP 800 (left), Sola Electric's Mini UPS/2 (middle), and the Emerson PC/ET (right) represent products designed for medium-, large-, and small-load requirements.

PRODUCT FOCUS
UNINTERRUPTIBLE POWER SYSTEMS

Table 1: A summary of critical UPS features.

	Price	Output power (VA)	Type	Waveform				
				Type	THD	RMS (V)	Reg.	Peak (V)
American Power Conversion 800RT	\$1099	800	Standby	Sine	2%	120	2%	170
Computer Accessories Power Saver U1200	\$1295.95	1200	Standby	Modified square	N/A	120	5%	165
Computer Power Computersave Mark II	\$2219	750	Standby	Sine	5%	120	2%	170
DRS Power Products UPS	\$654	1000	Standby	Modified square	N/A	115	N/A	145
Emerson PC/ET	\$995	360	On-line	Sine	5%	120	5%	170
Exide Electronics Micro UPS 800	\$1199	800	Standby	Sine	2%	120	5%	170
General Power EPD Unistar U1000	\$2699	1000	On-line	Sine	3%	117	2%	N/A
ITT PowerSystems VIP 800	\$1699	800	On-line	Sine	5%	120	3%	170
Kalglo Electronics Line-Saver LS-750	\$995	750	Standby	Modified square	N/A	120	4%	160
Sola Electric Mini UPS/2	\$3712	1000	On-line	Sine	5%	120	3%	170
Unison UniPower DP 800	\$995	800	On-line	Stepped square	N/A	115	5%	170
Viteq Benchmark Model 386/LAN	\$1895	750	On-line	Sine	5%	120	2%	170

¹ Includes detection and switching time.
² Specified recharge time may vary from 85 percent to 100 percent full charge.
³ Protection features key: NC = network connection, NF = noise filtering, and SS = spike suppression (tested to IEEE-587).
⁴ Specified as zero, some distortion for 8 ms.
⁵ Optional feature.
⁶ Number in parentheses indicates total outputs, including bypassed (not backed-up) outlets.

Table 2: The test results. The ideal UPS has an output voltage close to 120 volts at all times, and zero (or N/A) transfer times.

	Cutoff voltage (RMS)	Restart voltage (RMS)	Steady state output voltage (RMS)			Measured transfer time (ms)	
			Normal	Backup	Min.	Small load	Moderate load
American Power Conversion 800RT	101	105	117.5	122.0	101.5	6.6	6.0
Computer Accessories Power Saver U1200	99	100	118.9	120.3	100.2	4.8	4.6
Computer Power Computersave Mark II	86	91	120.2	122.4	118.5	0 ¹	0 ¹
DRS Power Products UPS	101	108	118.3	133.5	101.7	11.8	13.0
Emerson PC/ET	84	95	117.9	117.9	117.9	N/A	N/A
Exide Electronics Micro UPS 800	101	106	117.8	121.1	101.6	8.2	8.2
General Power EPD Unistar U1000	79	91	118.6	118.6	118.6	N/A	N/A
ITT PowerSystems VIP 800	96 ²	96 ²	118.3	118.3	118.3	N/A	N/A
Kalglo Electronics Line-Saver LS-750	102 ³	105	117.9	131.5	103.5	17.4	17.4
Sola Electric Mini UPS/2	94	103	119.3	119.5	119.5	N/A	N/A
Unison UniPower DP 800	96	104	122.6	121.4	121.3	N/A	N/A
Viteq Benchmark Model 386/LAN	82	92	116.7	117.2	116.7	N/A	N/A

¹ No abrupt switch, but voltage degradation (15 percent to 20 percent) for 12 ms to 16 ms.
² No clearly defined transfer point.
³ Default value; transfer levels are adjustable.

stress on the larger units. As was true with the moderate load, the large load was an even mixture of computers and monitors. We did not test any of the 750-VA units with the large load because the difference between rating and actual load left a very slim margin of error, less than some manufacturers recommend. We charged each UPS for 24 hours between tests, loaded them, and then disconnected them from the line.

Powerful Impressions

Our test results were the primary source of information used in evaluating these

UPSes. Other sources include features claimed by the manufacturer that may or may not be testable (e.g., long battery life or warranty) and subjective impressions. A summary of each UPS's performance follows.

American Power Conversion 800RT: The 800RT offers some valuable features at a reasonable cost of \$1099. Like all SPSes, this 800-VA unit cannot provide absolute uninterrupted power during an AC outage, but its transfer time is acceptable, and it generates a pure sine wave during backup operation.

The front panel sports a power switch, a test switch to simulate power outages, and a vertical row of indicator lights. Along with indicators for output ready, input power fault, overload, and low battery, the 800RT lights a site-wiring fault indicator when it detects a poor ground or reversed AC polarity.

You can also use the row of indicators as a utility voltage monitor or a load power gauge. If you press the alarm disable switch for 4 seconds, the row of lights becomes a bar-graph indicator displaying the input voltage level. If you press the test switch for 4 seconds, the

Transfer time ¹ (ms)	Full-load holdup time (minutes)	Battery-recharge time ² (hours)	Outlets	Other protection features ³	Warranty (years)	Size (inches)	Weight (lbs.)
4	5	10	6	NC, SS, NF	1	11.5 x 7.7 x 14.5	52
3	10	8	4	NC, SS, NF	1	16.5 x 6.4 x 18	74
0 ⁴	15	4	4	NC ⁵ , SS, NF	1	12.5 x 12.5 x 21	125
6	10	8	4	NC, NF	2	9 x 11 x 18	60
N/A	7	35 minutes	3 (6) ⁶	SS, NF	1	2.3 x 15 x 14.8	23
4	6	10	6	NC, SS, NF	2	11.5 x 7.7 x 14.5	52
N/A	10	N/A	3	NF	1	18 x 7.9 x 19.5	93
N/A	10	8	3 (5) ⁶	NC, SS, NF	1	10 x 6 x 16	39
4	11	12	2	NC ⁵ , SS, NF	2	5 x 8.5 x 13.2	38
N/A	8	2	4	NC, SS, NF	1	20 x 11 x 22	145
N/A	6	4	4 (8) ⁶	NC, SS, NF	1	2.9 x 18 x 16.5	34
N/A	10	2	4	NC, SS, NF	1	11.5 x 8 x 19.5	65

Measured holdup time (hrs:min:sec)		
Small load	Moderate load	Large load
0:43:37	0:15:47	0:07:21
2:05:55	0:44:15	0:23:34
1:09:55	0:35:26	N/A
1:08:10	0:29:51	0:14:43
0:12:25	N/A	N/A
0:40:05	0:15:41	0:07:28
2:22:30	0:41:38	0:20:25
0:56:22	0:22:51	0:11:35
0:30:04	0:07:59	N/A
1:08:26	0:36:34	0:21:07
0:33:45	0:10:19	0:05:13
0:44:22	0:17:33	N/A

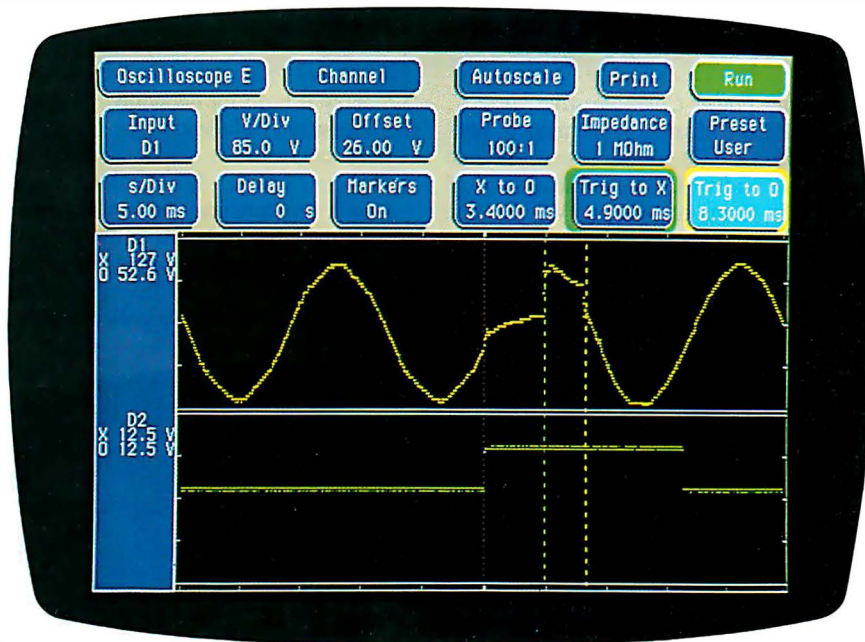

bar-graph indicator displays the protected load at thresholds of 130, 250, 360, 470, and 600 VA.

The 800RT provided 43 minutes and 37 seconds of battery backup for a small load, and 7 minutes and 21 seconds of backup for a large load. A continuous alarm sounds when the unit nears shutdown. The battery kicks in at 101 V, responding smoothly after a 6-ms transfer time. A network connection at the rear of the unit alerts any computer connected when shutdown is imminent, allowing supported software to respond by gracefully closing files. (This connector is

adaptable to many network systems, including Novell NetWare, Banyan or Tallgrass running VINES, and others.)

Computer Accessories Power Saver UI200: Though physical design is not normally an important criterion when selecting a UPS, this 1200-VA model certainly deserves credit for ease of installation. It has the heft usually associated with such a high-capacity unit, but solid carrying handles and a good rectangular layout make it easy to place and move. A lighted front-panel on/off switch is the only control necessary—and

Photo 1: Transfer-time measurement for standby power systems. The measurement is from disturbance to full recovery. (Shown here is the American Power Conversion 800RT waveform.)

the only one provided, though there is an audible power-fault alarm. The unit has a self-test that it performs at each start-up.

The battery is of average capacity, rated at 10 minutes full load. Its high VA rating does, of course, increase holdup

continued

time for smaller loads; our Model 80 and monitor were operational for over 2 hours with input power to the UPS disconnected.

At \$1295.95, the U1200 compares favorably to most of the other UPSes that we reviewed in the critical dollars-per-VA category. In terms of pure output quality, however, two factors weigh against this system: SPS design and non-sinusoidal output (see photo 2).

While the waveform type and transfer time are less than ideal, these problems are not as serious as they could be. The waveform is very close to sinusoidal (peak 165 and RMS 120), and the transfer time is relatively short. Transfers are also made in phase. The unit needs no hysteresis in the cutoff level, since the inverter remains on for at least 5 seconds regardless of the duration of the transient. Though the inverter mechanism is of a cheaper design than those of some of the more costly UPSes we reviewed, the better-than-average implementation stems some of the problems associated with the square wave/SPS scheme.

Computer Power Computersave Mark II: At \$2219, the Mark II is the most expensive 750-VA system we tested. It also ranks second to the Sola Electric Mini UPS/2 in terms of cost per VA. But the unit offers features in proportion to price: Sine-wave output, outstanding battery capacity, and an output storage transformer contribute to the Mark II's

good all-around performance.

This UPS has an odd appearance, with a large housing for the inverter and switching electronics connected via a back-panel cable to an external battery box. Its external battery design lets you add more batteries or replace worn-out modules without exposure to the potentially dangerous voltages inside the system. A power switch, an audible alarm, and front-panel LEDs provide control.

Though the Mark II is an SPS, the output storage transformer makes the effects of switching to the inverter almost unnoticeable and puts it in a slightly different category. The transformer is connected between the AC source (line or inverter) and the UPS output. While line-to-inverter switching takes place, the transformer holds up the output long enough to ensure a smooth transition. Transfer time is not easily measured from the scope trace, as the effect of switching is to degrade the output voltage about 15 percent to 20 percent for close to one cycle.

DRS Power Products UPS: DRS's 1000-VA entry is built for economy. Cost-saving measures include standby operation, a pure square-wave output, and limited spike protection. While the backup power it provides may be less than perfect, this UPS sells for only \$654—a quarter the price of the next most expensive 1000-VA unit, and the only system in the group at less than a dollar per VA.

The standby output is a square wave, which our measurements show has an RMS value around 133 V. Frequency on the unit we tested was near 66 Hz. DRS told us that our Model 80 test load was too small for this high-capacity unit and said that frequency variances are usually limited to between 58 Hz and 62 Hz.

Transfer time was relatively poor, rated at 6 ms and measured at 11.8 ms. The UPS also failed to switch on short-term (one-cycle) brownouts. Holdup time was poor compared with units of a similar power rating, but the system outperforms more expensive units with lower ratings.

One helpful feature that this no-frills device does provide is LED bar graphs to monitor load and battery charge levels. The bar graphs give a better indication of emergency power available than the usual audible alarm only.

Emerson PC/ET: The Emerson PC/ET provides true on-line protection for only \$995. While this compact unit supplies only 360-VA output from its three UPS-protected outlets, conditioned output is available from two additional sockets. The PC/ET generates a true sine wave and maintains remarkably consistent output regardless of input conditions.

Front-panel indicators monitor load level in 20 percent increments, battery charge, presence of AC power, and overload conditions. In addition to a master power button, each rear-panel outlet is controlled by its own front-panel switch. The unit furnishes noise filtering and spike suppression, but it has no network connection. Battery power lasted 12 minutes and 25 seconds while connected to a small load. The low VA rating prevented us from testing the other two loads.

This on-line UPS looks tempting when you see the low price tag, and if your power requirements are modest, you should give it a look. Upon closer inspection, however, the PC/ET is not as cheap as it seems. Only the Mini UPS/2 and the Computersave Mark II are more expensive when considering cost per VA. It does offer true uninterruptible power for less than \$1000, a viable alternative to the inexpensive standby units.

Exide Electronics Micro UPS 800: This \$1199 unit provides 800-VA standby power from six rear sockets. It supplies spike suppression, noise filtering, true sine-wave output, and a network interface.

Front-panel indicators are identical to those on the 800RT, including the diag-

continued

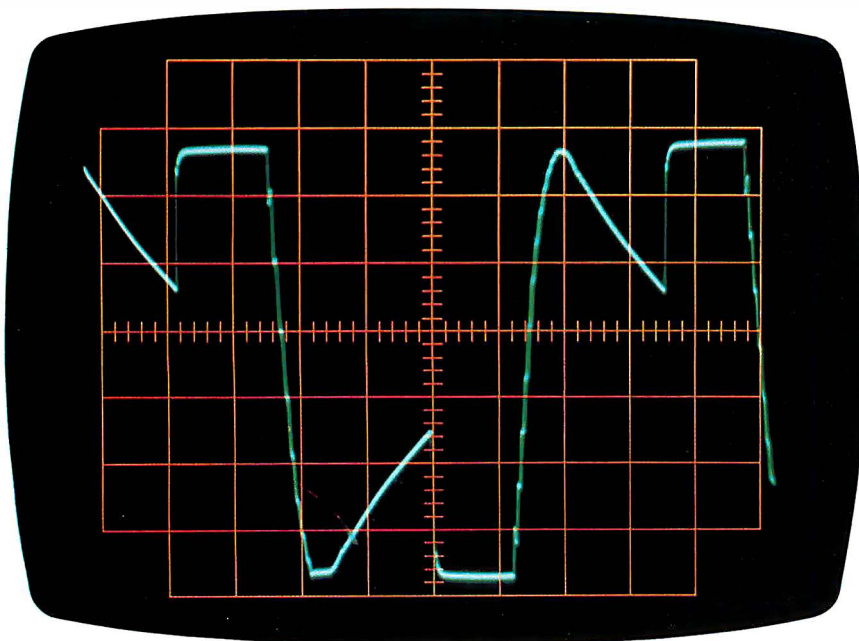

Photo 2: The modified square-wave output of the Computer Accessories Power Saver U1200.

The smart buy for PC Power Protection is now . . .

The Smart UPS For LAN's

. . . Reliable Protection From Data Loss

MINUTEMAN[®]
UNINTERRUPTIBLE POWER SUPPLIES

TOTAL POWER PROTECTION:

- BLACKOUTS
- BROWNOUTS
- OVERLOADS
- OVERVOLTAGE
- SURGES/SPIKES
- EMI/RFI

"For All Sensitive Electronic Equipment"



- A unique software package that interfaces your LAN's and Minuteman UPS system for an automatic and orderly network shutdown due to power failures . . . before data loss occurs!
- Compatible with SCO XENIX 2.2.3
Compatible with Novell Systems:
ELS 2.12 and above
Advanced Netware 2.10 and above
SFT Netware 2.10 and above
- Selectable power loss warning times and shutdown times
- Instantaneous user notification
- Also interfaces to Wide Area Networks
- Auto Shutdown of UPS for unattended operation
- The only software available that supports ELS Level II
- No Novell monitoring hardware required

Power Output	120 Volt Models	230 Volt Models
250 WATT	\$ 379.00	\$ 429.00
300 WATT	\$ 549.00	N/A
500 WATT	\$ 699.00	\$ 799.00
600 WATT	\$ 899.00	\$1049.00
900 WATT	\$1249.00	N/A
1200 WATT	\$1499.00	\$1749.00
1600 WATT	\$1999.00	\$2299.00

Suggested Retail

- One millisecond transfer time *
- Synchronized sinewave *
- Full one year warranty
- Order-Ship same day

* 250 watt and 500 watt units offer 4 msec transfer time, PWM waveform

See us at COMDEX-Chicago, Booth #3033

Circle 209 on Reader Service Card



PARA SYSTEMS, INC.

1455 LeMay Drive
Carrollton, TX 75007

Telephone:
(214) 446-7363

1-800-238-7272

FAX: (214) 446-9011

TELEX: 140275 OMEGA

APRIL 1989 • BYTE 167

What Is a UPS?

Mark Waller

The acronym UPS stands for "uninterruptible power system." Notice that this is not a power *supply*. It is an external *system* for providing continuous power when the utility supply fails. A power supply is a subassembly inside the microcomputer that converts the utility's AC power to DC, which is what the logic circuits of the microcomputer need for working energy.

To make matters a little more complicated, not every UPS is truly uninterruptible. These units are more correctly called standby power systems (SPSes). Also, some designs are uninterruptible and yet standby at the same time.

The reason for this blurring of terms is related to the microcomputers themselves. A microcomputer's power supply has what is called *ride-through*: the amount of time that the power supply can deliver stored energy to the logic circuits with no electricity being fed to the supply. This energy storage is directly related to the size and quality of the power supply components, particularly the filter capacitors. The ride-through of microcomputers is from 20 milliseconds to 40 ms—a long time in the world of electronics. Some designs have an even greater tolerance for very short-term dropouts.

The SPS

This long ride-through allowed the SPS to become the most popular of these devices for the microcomputer market. Figure A shows the block diagram of an SPS. The incoming utility power is fed directly into the microcomputer under normal conditions. When utility power fails, the transfer switch senses this happening and turns on the inverter, which converts battery power (DC) into an AC source that keeps the microcomputer running.

When utility power returns, the switch returns the microcomputer to utility power. It is easy to see why this is a standby technology. The inverter is literally "standing by" waiting to be turned on.

The UPS

So what is a true UPS? Figure B shows the block diagram of a true on-line UPS. The incoming utility power is converted from AC to DC by a *rectifier/charger*.

As the name implies, this unit performs two functions: It changes the power to DC (the rectifier) and charges the battery. The battery floats on a DC bus (i.e., the conductor that connects the rectifier/charger and the inverter). If the battery needs charging, it draws power from the bus. If, on the other hand, the bus voltage level falls below the battery float voltage, the battery delivers energy to the bus.

The energy conducted through the DC bus provides power to the inverter (which, in turn, provides power to the microcomputer). In other words, the system is on-line all the time. Thus, a full-time AC-to-DC-to-AC conversion takes place. The advantage of this design over the standby design is that no switching takes place if utility power fails. Since the inverter is always providing power to the load (the microcomputer), the microcomputer never sees an interruption of power.

This feature comes at a price, however. Since the duty cycle of the components is 100 percent, they must be bigger with higher ratings. This means that the on-line design can cost twice as much or more than a standby unit of the same rating.

One More Design

A *ferroresonant transformer*, designed many years ago, has the unique ability to store energy for a few tens of milliseconds. Figure C shows how this device can enhance the performance of the simple SPS. Notice that all the blocks are the same, but that the transformer has been added at the output. With this design, the time that it takes to switch on the inverter is covered with the ride-through capability of the transformer. Therefore, the microcomputer is unaware that any switching has taken place.

A ferroresonant transformer adds cost to the basic SPS. It also adds some power conditioning. Expect to see prices for these units somewhere near but not quite as expensive as the on-line variety.

Features

What features should you look for when purchasing an SPS? The first concern is switching time. The unit must be able to

switch its inverter on and gracefully pick up the electrical load before the microcomputer's internal ride-through expires. Typical switching times are from 4 ms to 10 ms, including the time it takes to sense an outage and complete the switching process. The SPS does this by setting an internal transfer point. When the utility voltage (120 volts) falls below a predetermined level, say 100 V, the SPS begins the switching process. This ensures that by the time voltage reaches a dangerously low level, the microcomputer will already be on-battery.

A selectable transfer point is an important feature. The switching power supply inside most microcomputers has a working voltage window that is enormous, from about 80 V to nearly 140 V, implying that voltage regulation is not normally necessary. It also implies that if your site experiences chronic brown-outs or low-voltage conditions, you may want to buy a unit that lets you select a low transfer point (possibly in the 90-V range) so that you are not unnecessarily transferring to a battery.

The next feature to look for is an extension of the transfer point, referred to as *hysteresis*. This means that the re-transfer point (the voltage at which the SPS goes off-battery when utility power returns) should be above the transfer voltage so that "chattering" on- and off-battery does not occur if the utility voltage hovers near the transfer point. A typical hysteresis window might have a low of 102 V and a high of 107 V.

When an SPS retransfers, you want the waveform output of the inverter to slew to match the phase of the incoming utility power. This is called *synchronizing* or *phase matching*. When the two waveforms are in phase, no gap will occur when retransfer takes place. Can this gap be long enough to be interpreted as an outage by the microcomputer? Engineers might disagree about this probability, but designing this feature into the product shows professional concern for the quality of the device.

Low-battery shutoff is another feature to look for. When batteries power a load during a power outage, their stored energy is slowly depleted. At some point, the depletion is so dramatic that the voltage level of each cell in the bat-

tery begins to drop. At a level called the *end voltage*, further discharge will permanently damage the cell. To preserve the life of the battery, most quality SPSes shut off the inverter before this happens. Without this feature, your SPS may survive only a few long-term outages. Ideally, of course, you will shut down the microcomputer and the SPS before this happens.

Waves

Most of us are familiar with the sine waveform of utility power. However, most SPSes do not put out a sine wave; it is considerably cheaper to put out a square wave, a rectangular wave, or some quadrilateral in between.

The inverter, you see, is basically a very fast switch. To produce a sine wave, a switching scheme must be devised that builds some kind of approximation to a sinusoid using a series of pulses. This is then filtered to produce a smooth product that looks like normal utility power.

The switching process of the inverter creates a lot of high-frequency electrical noise. To produce a sine wave, most of this noise is eliminated during the filtering process. With a square wave, on the other hand, no such filtering is necessary to produce power that the microcomputer will run on. However, the chance that inverter noise will be present at the SPS's output is far greater. Add to that the fact that a square wave is not a fundamental of 60 Hz (the frequency of power), as is a sine wave. The "shoulders" of the waveform contain odd harmonics of the fundamental 60-Hz signal.

This means that the manufacturer must take care to eliminate noise from the nonsine wave of an inverter. (If this is done, there is no real reason to shy away from nonsine-wave products.) As a result, sine-wave units typically put out less interference and cost more money.

Power Conditioning

Damaging impulses or spikes come in two different varieties: normal mode and common mode. Normal-mode events can be measured between the black building wire (hot) and the white building wire (neutral). Common-mode events are measured from the white building wire to ground (see my two-part "PC Power" in the October and November 1988 BYTE). A normal-

continued

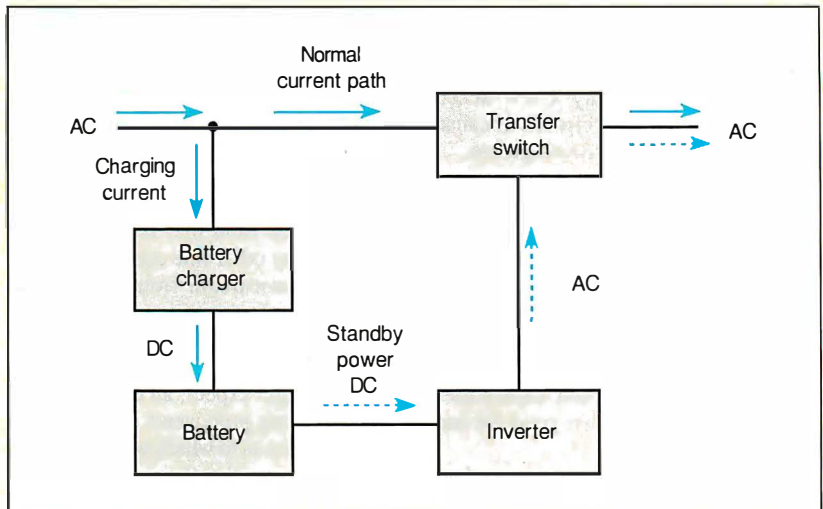

Figure A: The block diagram of a standby power system.

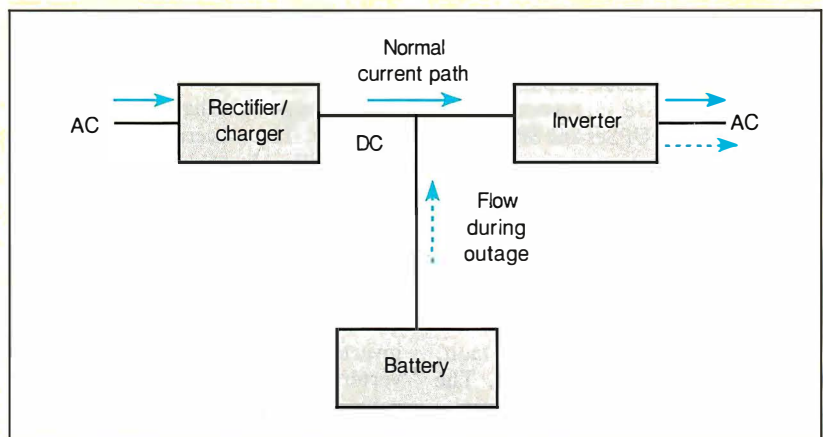

Figure B: The block diagram of a true on-line UPS.

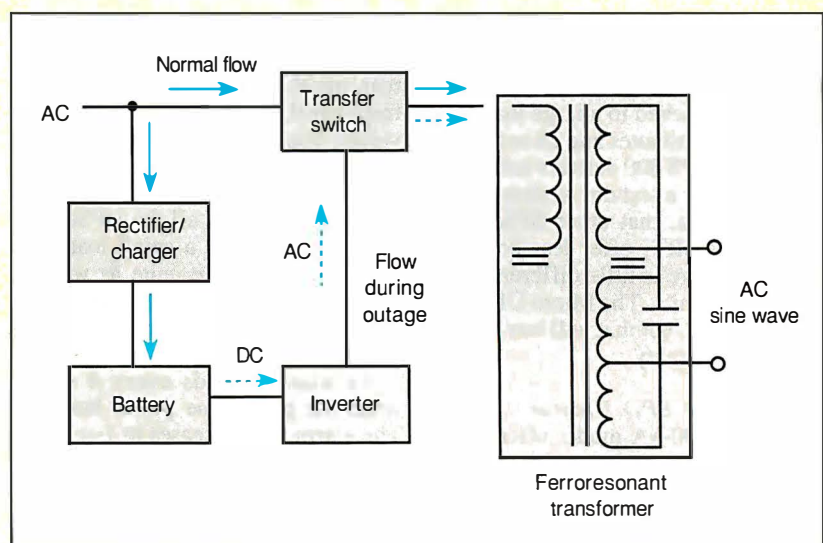

Figure C: The block diagram of a ferroresonant UPS.

mode spike of high magnitude will almost always affect the power supply of the microcomputer. However, a common-mode spike of only a few dozen volts can blow out logic circuits or cause soft errors between microcomputers.

Surge suppressors are good protection against normal-mode spikes, but their clipping action can cause common-mode spikes of even greater magnitude. Many SPSes tout surge protectors inside their units. Most experts agree that an SPS is an inadequate power conditioner. In fact, many manufacturers misrepresent the surge-suppression capabilities of their devices. SPSes are good for one thing: backup power.

On-line UPSes are hyped as excellent power conditioners. This is true only for normal-mode events. The double conversion process of the on-line design will suppress high-energy impulses appearing between line and neutral. However, the on-line design does nothing to prevent common-mode impulses from getting to sensitive equipment. As a matter of fact, all UPSes and SPSes generate significant common-mode noise. Far from conditioning power, UPSes become the culprits.

A transformer solves this problem. A transformer has its neutral and ground

bonded together, shorting out common-mode noise. The transformer itself can be part of an excellent design to thwart normal-mode events.

The ferroresonant design is a good power-line conditioner for both normal-mode and common-mode events. This makes the SPS/ferroresonant design a good choice from that standpoint. But you can buy other line conditioners that plug in downstream from an SPS and provide similar benefits.

Switching Off

As you might expect, an ongoing battle wages among proponents of the various technologies as to which is best. The on-line people say that theirs is the best because the inverter is on-line all the time. Thermal stress is not a worry since they are not "cold-starting" the inverter when utility power fails. The standby manufacturers say that theirs is more reliable since the inverter is on only when power is out.

Both arguments have the ring of truth to them. The concern is not which design philosophy to agree with. The real question is how well did the company engineer the system. If an SPS is not designed to pick up the load gracefully, the most reliable components in the

world will fail. On the other hand, if the on-line unit is not carefully engineered, thermal stress will cause premature failure while the unit is running.

Also, inverter design is not the Achilles' heel of any UPS. Two far more important factors are quality control and batteries. Many small UPSes are manufactured overseas, usually along the Pacific Rim, and they are shipped to the U.S. in boxes that are never opened and never checked. This can result in rates of initial failure of over 5 percent. One firm even found a pair of pliers inside a failed SPS. An even more common trouble area is batteries—the single most frequent point of failure for any UPS.

There is virtually no limit to the variations of the uninterruptible designs presented here. Expect to see hybrids, innovations, and exceptions. But a working knowledge of the basic designs shown here will prepare you for some of the more creative options that you might discover.

Mark Waller is a computer facilities consultant and the author of Computer Electrical Power Requirements and Mastering PC Electrical Power, both published by Howard W. Sams. He can be reached on BIX c/o "editors."

nostic indicators for site-wiring fault, voltage level, and load thresholds. The battery kicks in at 101 V and maintains a consistent sine-wave output for over 40 minutes while connected to a small load. A continuous alarm alerts you when the Micro UPS 800 is approaching shutdown, and the unit transmits a warning message from the rear interface port (this port is identical to the 800RT's network port). Attached to a large load, the battery lasted 7 minutes and 28 seconds.

The Micro UPS 800 delivers sufficient performance for a standby system. Keep in mind, though, that other SPSes, including the 800RT, offer less cost per VA. In fact, there is little difference between the two units. The Micro UPS 800 costs \$100 more, but that will buy you an extra year's warranty.

General Power EPD Unistar U1000: This sturdy 1000-VA model offers continuous on-line protection for \$2699. The unit boasts consistent sine-wave output, top-notch battery capacity, spike suppression, noise filtering, and overload protection.

The front-panel line input light glows green when AC power is available. The

inverter output light indicates proper inverter operation. An amber bypass indicator lights when the bypass source is providing output power. Finally, a red fault indicator warns of system overload, battery depletion, or inverter failure.

You can manually transfer from the inverter to bypass power using the unit's off/reset button. While a switch on the rear panel controls master power, the front-panel on switch activates the inverter. You are limited to three rear output sockets.

This heavy-duty unit posted the longest holdup time of all the UPSes tested when connected to a small load. However, it did not fare quite as well with larger loads, finishing in second place on the moderate-load test and third on the large-load test.

An alarm sounds every 4 seconds when the power-line power has failed. The alarm rate increases to 1-second intervals when shutdown is imminent. The powerful battery and on-line design deliver maximum protection, consistent output, and reliability. The unit comes up short on sockets and network connectivity, but that does not denigrate its impressive credentials.

ITT PowerSystems VIP 800: This \$1699 UPS comes from a manufacturer with a solid reputation for quality; the VIP 800 is unlikely to damage that reputation. It's a compact, lightweight design that delivers 800-VA capacity, a smooth sine wave, uninterrupted power, and very respectable holdup times.

Our undervoltage tests produced no noticeable effect on the output of the on-line system. The VIP 800 continued its steady sine-wave output despite long- and short-term interruptions. Holdup time was better than that of any other 800-VA unit we tested.

The front panel has a power switch, LED bar graphs for load and charge, and alarm LEDs. The small, light, rectangular design makes it suitable for desktop or floor-standing operation.

In terms of VAs per dollar, the VIP 800 is the least expensive on-line/sine wave unit we reviewed. Its reliable power and good capacity make it worth consideration for any application with compatible load requirements. If we have one complaint about this system, it's the continuous alarm that sounds at power failure (most UPS alarms are intermittent).

continued

This could be the most productive phone number you call today. Toll free. 1(800)531-5369

(Or, if you prefer to FAX your order—1 (512) 344-2985.)

TrippLite® Battery Back-Ups

Protect your equipment and data by providing safe shut down time for your computer systems and other sensitive equipment during black or brown-outs. Data loss from one black-out can cost you hundreds, if not thousands of dollars. These units feature AC line spike and noise suppressors, status indicator lights and heavy gel-cell batteries—a regulated battery charger automatically restores battery to full charge when AC power returns.

\$1299.00

\$239.00
\$299.00
\$599.00

BC-200
200-W

BC-325
325-W

BC-750
750-W

SC-BC-2000
2000-W

BC-1200
1200-W

BC-450
450-W

This complete TrippLite® Series offers reliable battery back-up at an extremely low price. \$799.00 \$399.00

TrippLite® Voltage Regulator—Line Conditioners

\$79.00 \$149.00 \$199.00

LS-600 LC-1200 LC-1800

TrippLite® Line Stabilizer/Conditioners automatically adjust varying input voltage to provide full voltage support during a low voltage condition while suppressing spikes and line noise.

OMNI Power Director



CC16-P

\$79.95

TrippLites' ISOBAR command console provides the highest level of surge and noise suppression of any console unit on the market today. Features include 6 outlets, 5 lighted power switches, protection indicator light, 15 amp circuit breaker and 12-foot power cord.

Eprom Programmer



\$179.95

EW-904

You can program your own EPROMS with this EPROM programmer—it can program up to 4, 16K thru 512K EPROMS simultaneously—easy to use software is included.

Eprom Eraser



LA-6T

\$79.95

You can erase your EPROMS quickly and easily at home or workplace with this easy to use EPROM eraser with built-in timer. It features an adjustable exposure time with alarm and is static protected. Without timer (not shown). LA-6A \$59.95

Cable Assemblies

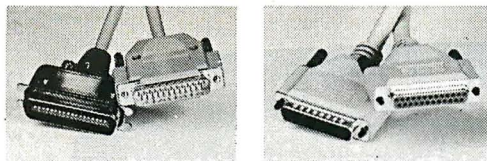

PC/AT Parallel Printer Cables

DB-25 - 25 Line Cables Male-Male

Stock #	Length	Price	Stock #	Length	Price
PPC301-6	6 ft.	\$ 6.95	25MM-6	6 ft.	\$ 6.95
PPC301-10	10 ft.	7.95	25MM-10	10 ft.	7.95
PPC301-15	15 ft.	11.95	25MM-25	25 ft.	17.95
PPC301-25	25 ft.	17.95	25MM-50	50 ft.	33.95
PPC301-6RA	6 ft.	12.95	25MM-100	100 ft.	62.95

POPULAR CABLES

Stock#	Description	Price
MEC-6	Monitor Ext.	\$5.95
KEC-6	Keyboard Ext.	3.95
ACPC-03	Power Adapter	4.95
ATM-6	AT Modem Cable	5.95

DB-25 - 25 Line Cables Male-Female

Stock #	Length	Price
25MF-6	6 ft.	\$ 6.95
25MF-10	10 ft.	7.95
25MF-25	25 ft.	17.95
25MF-50	50 ft.	33.95
25MF-100	100 ft.	62.95

Altex Electronics, Inc.

"Your Electronics Supply House"

TERMS: Minimum order \$10.00. We accept Mastercard, Visa, and American Express at no additional charge. For C.O.D. orders, add \$2.20. For orders under \$100.00, add \$3.00 handling and actual UPS shipping charges. For orders over \$100.00, we pay handling charge—you pay actual UPS shipping charges plus insurance. Purchase orders accepted from approved accounts. All returns require an RMA# and are subject to a restocking fee. Texas residents add 7.5% sales tax. Prices subject to change and we are not responsible for typographical errors.

Store Hours: 8:00-6:00 M-F, 10:00-2:00 SAT CST
10731 Gulfdale, San Antonio, Texas 78216

Hard Drive Cases



SDH-2H \$99.00

This sturdy metal cabinet is capable of handling up to two 1/2 height hard disk drives—comes complete with fan, switching power supply and mounting hardware. (Drive cables not included) 14 7/8" W X 13 7/8" D X 2 5/8" H.

Switchboxes



These sturdy metal switchboxes allow you to share computers, printers and other peripherals quickly and easily. They have gold-plated contacts and are EMI-RFI protected.

DB-25 25 Line Switchboxes

Stock #	Description	Price
AB25-2	Two position	\$19.95
AB25-3	Three position	23.95
AB25-4	Four position	29.95
AB25-5	Five position	34.95
AB25-6	Six position	38.95
AB25-X	Cross over	59.95

Centronics 36 Line Switchboxes

Stock #	Description	Price
AB36-2	Two position	\$23.95
AB36-3	Three position	29.95
AB36-4	Four position	34.95
AB36-5	Five position	44.95
AB36-X	Cross over	37.95

We carry a complete line of switchboxes for your different requirements. Call for more information!

The noise can be very distracting if a failure occurs and you choose to work for a few minutes before shutting down.

Kalglo Electronics Line-Saver LS-750: The Line-Saver delivers standby protection to a 750-VA load for \$995. The unit boasts a low price and has a two-year warranty, but its battery capacity is low, and it does not generate a true sine wave.

A traffic-light icon displays the system

status on the front panel. The green light confirms proper AC operation. The yellow light illuminates when the inverter is on and blinks increasingly fast as the battery depletes. When the load is too heavy or the battery is extremely low, the red light warns of imminent shutdown. An intermittent alarm also becomes steady at this point. The rear panel contains a pair of outlets and an external DC input. The unit supplies noise filtering and

surge suppression, but a network interface is optional.

When AC power fails, the Line-Saver produces a pulse-width-modulated waveform with an RMS voltage equivalent to the line. We discovered some problems when the unit faced degraded conditions within 30 percent of normal. The inverter did not switch as cleanly as it did when handling a full-cycle wave during our near-blackout test. In any case, the transfer time was the longest of any standby system we tested (see photo 3).

Some equipment will not work well with a full-cycle wave, but this unit had no problem with the wide range of components we plugged into it. Our RMS meter also registered high output voltages when the Line-Saver switched to the inverter. (Kalglo claimed that this was a natural effect of computers' switching power supplies.)

The Line-Saver LS-750, a small box with a surprisingly high VA rating, suffers from some significant drawbacks. It posted the longest transfer time and shortest battery life of the units tested. We'd also like to see a true sine-wave output. It simply can't compete with other systems in its price range.

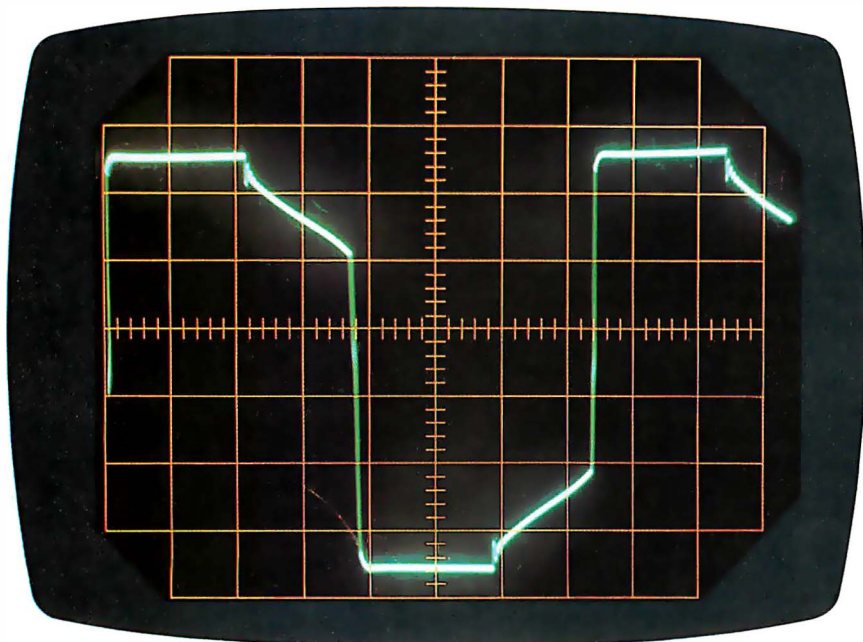

Photo 3: The Kalglo Electronics Line-Saver LS-750 modified square wave.

Sola Electric Mini UPS/2: As its \$3712 price suggests, the Mini UPS/2 belongs in a different class than the other units reviewed here. While it shares some of the same features, it also offers special protection. It is an on-line unit, rated at 1000 VA, that generates a consistent sine wave and delivers long battery life.

Front-panel indicators include battery OK, bypass, overload, battery low, and AC fail. The battery OK light blinks when the battery is recharging. When power fails, the red AC fail light illuminates, and an alarm sounds every 3 seconds. The unit beeps more frequently when it approaches shutdown, and it attempts to alert connected equipment through the RS-232C interface at the rear of the unit.

The RS-232C interface also returns vital status data when prompted from a host computer. The host can request such information as battery voltage, input voltage, output voltage, output current, and excessive temperature readings. The rear panel also includes four outlets, a master circuit breaker, and external battery connections.

The Mini UPS/2 attains true output isolation with a built-in shielded isolation transformer. Line frequencies as low as 40 Hz will continue to charge the battery, even with a full load. A static transfer

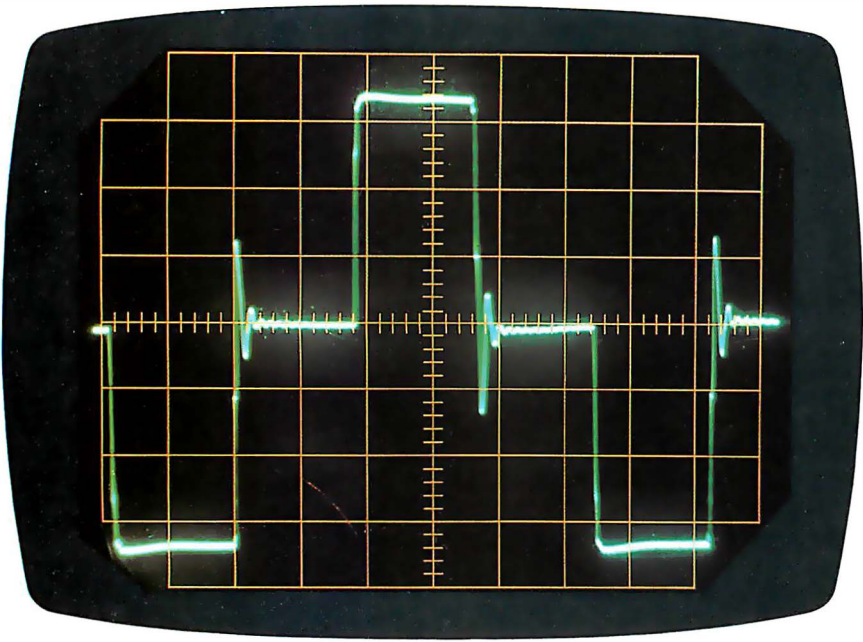

Photo 4: The Unison Stepped Square wave, another sine wave approximation.

continued

Pop Quiz. Stop. This is a test. For the next 60 seconds, we will be conducting a quiz about Macintosh® II Videographics. Do not turn the page until you have looked at the visual clue and answered all the questions.

Which Macintosh II graphics card offers the widest range of capture and display resolutions—NTSC, PAL, Apple® Monitor, hi-res, interlaced, non-interlaced and other modes?

- a) NuVista 2M b) NuVista 4M c) All of the above

Name the only videographics card which provides true-color, real-time capture and broadcast-quality display while occupying only a single slot in a Macintosh II.

- a) NuVista 2M b) NuVista 4M c) All of the above

Which videographics card offers full QuickDraw™ compatibility at 1,2,4,8,16 or 32-bits per pixel?

- a) NuVista 2M b) NuVista 4M c) All of the above

Visual clue for Videographics test.

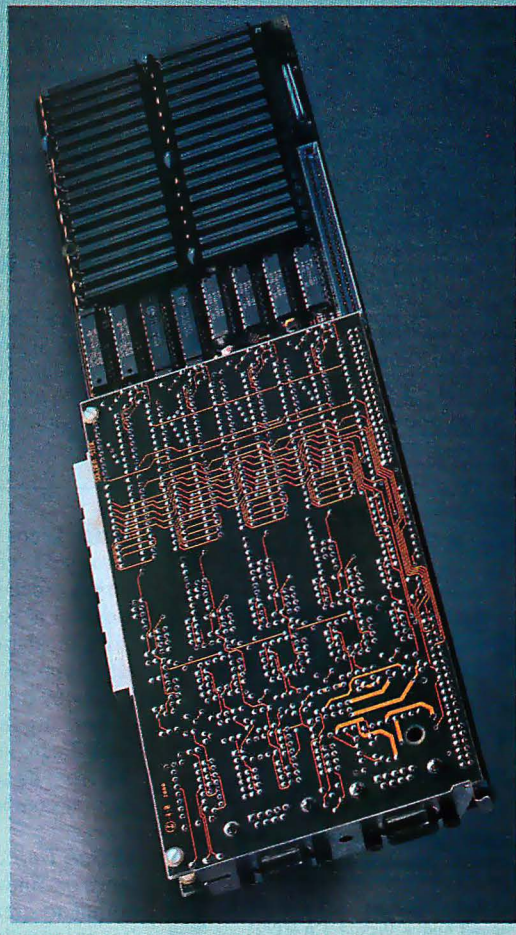

If you chose (c) on all three questions, congratulations! You know that the NuVista series from Truevision is the answer to all your advanced videographics needs. The NuVista is available with either 2Megabytes or 4Megabytes of video memory, and creates professional video effects and computer graphics using any QuickDraw compatible software, now and in the future. No patches, no gimmicks, no hassles.

So whether your application is video production, digital pre-press, presentation graphics or 3D renderings, you'll find the NuVista will pass *your* test with flying colors. Oh, and if you answered (a) or (b) to any question above, give yourself half credit. Then obtain even more NuVista information by requesting a copy of our educational brochure True color? True answers. or visiting your local Authorized Truevision Reseller. Either way, you can find all the answers with a NuVista. Call us at **800-858-TRUE.**

You may now return to your regular reading.



7351 Shadeland Station, Suite 100, Indianapolis, IN 46256
 INTERNATIONAL: Canada 416/499-9400 France 33-13-952-6253 Italy 39-2-242-4551 Switzerland 41-1-825-0949 U.K. 44-1-991-0121
 West Germany 49-89-612-0010 Other 617-229-6900

Apple and Macintosh are registered trademarks and Quick Draw is a trademark of Apple Computer. Truevision is a registered trademark and NuVista is a trademark of Truevision, Inc. © Truevision Inc. 1989

Circle 285 on Reader Service Card

Rack & Desk PC/AT Chassis

Integrand's new Chassis/System is not another IBM mechanical and electrical clone. An entirely fresh packaging design approach has been taken using modular construction. At present, over 40 optional stock modules allow you to customize our standard chassis to nearly any requirement. Integrand offers high quality, advanced design hardware along with applications and technical support *all at prices competitive with imports*. Why settle for less?

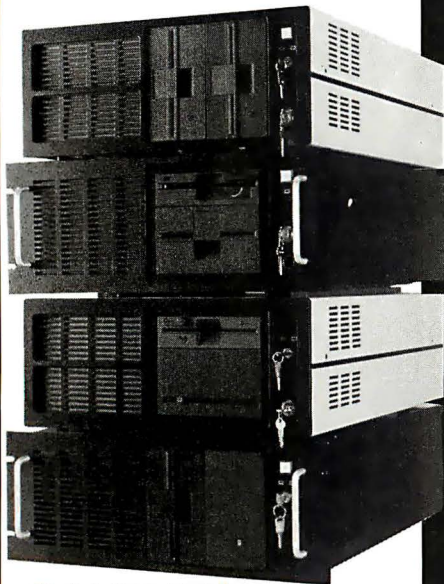

Rack & Desk Models

Accepts PC, XT, AT Motherboards and Passive Backplanes

Doesn't Look Like IBM

Rugged, Modular Construction

Excellent Air Flow & Cooling

Optional Card Cage Fan

Designed to meet FCC

204 Watt Supply, UL Recognized

145W & 85W also available

Reasonably Priced

Now Available
Passive Backplanes

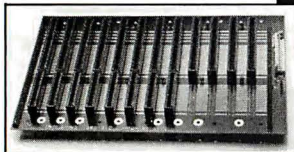

Call or write for descriptive brochure and prices:
8620 Roosevelt Ave. • Visalia, CA 93291

209/651-1203

TELEX 5106012830 (INTEGRAND UD)

FAX 209/651-1353

We accept Bank Americard/VISA and MasterCard

IBM, PC, XT, AT trademarks of International Business Machines. Drives and computer boards not included.

Companies Mentioned

American Power Conversion Corp.
350 Columbia St.
Peace Dale, RI 02883
(401) 789-5735
Inquiry 1024.

Computer Accessories Corp.
6610 Nancy Ridge Dr.
San Diego, CA 92121
(619) 457-5500
Inquiry 1025.

Computer Power, Inc.
124 West Main St.
High Bridge, NJ 08829
(201) 638-8000
Inquiry 1026.

DRS Power Products, Inc.
2065 Range Rd.
Clearwater, FL 34625
(813) 443-0345
Inquiry 1027.

Emerson Computer Power
3300 South Standard St.
P.O. Box 1679
Santa Ana, CA 92702
(714) 545-5581
Inquiry 1028.

Exide Electronics Corp.
3301 Spring Forest Rd.
Raleigh, NC 27604
(919) 872-3020
Inquiry 1029.

General Power Systems
1045 South East St.
P.O. Box 65008
Anaheim, CA 92805
(800) 854-3469
Inquiry 1030.

ITT PowerSystems Corp.
1371 State St., Suite 598
Galion, OH 44833
(419) 468-5200
Inquiry 1031.

Kalglo Electronics Co., Inc.
6584 Ruch Rd.
Bethlehem, PA 18017
(215) 837-0700
Inquiry 1032.

Sola Electric
1717 Busse Rd.
Elk Grove Village, IL 60007
(312) 439-2800
Inquiry 1033.

Unison Technologies, Inc.
23456 Madero
Mission Viejo, CA 92691
(714) 855-8700
Inquiry 1034.

Viteq Corp.
10000 Aerospace Rd.
Lanham, MD 20706
(301) 731-0400
Inquiry 1035.

switch keeps the inverter frequency synchronized with the AC line. If start-up surges exceed the inverter's capabilities, the load is switched to bypass without a shift in phase or frequency. This UPS also supplies noise filtering, spike suppression, and short-circuit protection.

For rugged applications, the Mini UPS/2 can do the job, but users will benefit from its sophisticated design even for regular computer loads.

Unison UniPower DP 800: Unison combines on-line operation with square-wave output to create the UniPower DP 800. Its unique design makes the DP 800, listed at \$995, one of the two least expensive on-line systems we reviewed.

Like the \$995 Emerson PC/ET, this 800-VA unit is designed as a flat box, which is suitable for placement between

the system unit and the monitor. On/off switches are provided for the four backed-up and four bypassed power outlets. The UPS also has lights that illuminate the keyboard during power failure, solving a not-so-obvious problem associated with shutting down a system during a blackout.

As an on-line unit, the DP 800 showed no output effect when hit with brownout voltages. On the downside, holdup capacity is limited; the unit had the weakest holdup times among the 800-VA units and was even outperformed by some of the 750-VA units.

The biggest question mark in evaluating this unit is its unusual output waveform (see photo 4). The wave is designed to supply power the same way a switching power supply demands it: in discrete

continued

INTRODUCING ENTITY COMMON LISP

- FULL COMMON LISP FOR THE 386, MS-DOS & MS-WINDOWS -

One of the greatest challenges of today's AI is delivering sophisticated applications at reasonable cost. AI is a technology to be integrated into a standard business environment. Lisp is a great way of developing complex software but this far Lisp-based applications have been costly to deliver.

Entity Common Lisp just changed that!

Entity Common Lisp runs on standard 386 PCs under MS-DOS and uses MS-Windows to provide a flexible graphics user interface.

Entity Common Lisp provides Common Windows as a high level interface to Windowing.*) The development environment includes an integrated emacs-style editor and an extensive set of debugging tools.

\$995 full version - \$195 interpreter-only version - available now!

THE FACTS:

- 2 MB extended Memory to run, 4 to develop.
- 1.4 MB Run Time size including all Common Lisp, Common Windows and input Editor.
- 1.5-3 times faster than the competition.
- Interface to C and other applications through MS-Windows.



ExperTelligence, Inc.
5638 Hollister Avenue
Goleta CA 93117
tel: (805) 967 1797
fax: (805) 964 8448
(800) 828 0113
(800) 826 6144 in CA

FOR ADDITIONAL INFORMATION PLEASE CONTACT:

Intellitech Ltd.
Hietalahdenkatu 2
00180 Helsinki
Finland
tel: +358 0 605 604
fax: +358 0 603 639

Intellitech U.K. Ltd.
5 Omega Gate,
Greenland Dock,
London SE16 1PR
tel: +44 1 237 8237
fax: +44 1 252 1625

gulps at waveform peaks. The 115-V RMS and 170-V peaks are close to the figures for a sine wave, so linear loads accept it as well. As with any nonsine wave, however, the short-duration square wave provides additional harmonics that can stress loads expecting a sine-wave input.

Viteq Benchmark Model 386/LAN: The 386/LAN falls in the middle of the pack on most of our measures of price and per-

formance. Rated at 750 VA and selling for \$1895, it does not quite reach the high-priced realm of the Computersave Mark II, but it does not qualify as a low-cost power solution, either. The 386/LAN features on-line operation, a network interface, and sine-wave output for a moderate price.

Our 30 percent sag tests generated no disturbance in the output waveform. In fact, the 386/LAN's output RMS voltage wavered only 1/2 V under all our test con-

ditions, well within our margin-of-measurement error. Holdup time was average for the unit's rating, but recharge time was quite good. Short recharge time can be a valuable asset if power failures are relatively frequent.

The system features a relatively compact design and front-panel LED bar graphs for load and charge indication. There is also an audible alarm and a network interface connector (compatible with Novell and Banyan file servers), from which the 386/LAN gets its name.

The Supplies in Demand

Selecting a UPS depends heavily on the load you are trying to protect. As with any purchasing decision, inevitable trade-offs emerge. On-line operation ensures greater protection, but the usable lifetime of the battery may be reduced, since it's always in operation. And you have to pay for the on-line design. True sine-wave output is desirable over modified square waves, but you'll have to pay for that, too. Extra features like network interfaces are nice, even prerequisites in some situations, but you'll... well, you get the picture.

The Sola Electric Mini UPS/2 attains Cadillac status. If you aren't too concerned about price, and absolute top-notch protection is your principal goal, you can't go wrong with the Mini UPS/2. We thought that, even with all its perks, it was just too expensive, given the scope of this roundup.

The Emerson PC/ET has a nice price tag for an on-line system, and it performed valiantly on our tests. We liked the sleek design and ease of operation. Only the low VA rating holds it back, but for single-system protection, it's a solid choice.

Our favorite system of the bunch was ITT PowerSystems' VIP 800. It provides all the features required in a quality UPS: sine-wave output, on-line operation, and good holdup time. Its price-to-power ratio also makes it attractive to those concerned with cost as well as quality. And when the lights dim, you can breathe a little easier, knowing that your investment has indeed paid off. ■

BIBLIOGRAPHY

"IEEE Recommended Practice for Design of Reliable Industrial and Commercial Power Systems." IEEE STD 493-1980.

Steve Apiki and Stanford Diehl are BYTE Lab testing editors. Rick Grehan is the director of the BYTE Lab. They can be reached on BIX as "apiki," "sdiehl," and "rick_g."

3 1/2 INCH 1.4 MB DISKS FOR ONLY ONE DOLLAR!

New Invention Makes It Possible!

Do you use the new, high capacity, 3 1/2 inch disks? If so, you have paid four, five, even six dollars per disk! Byte for byte, that is as much as SIX TIMES the 'old' 360K floppies. Now you can convert all your programs, data, and files to the new format, WITHOUT PAYING THESE PRICES!

HOW IS THIS POSSIBLE? Have you ever tried to format a regular, 'low density' 3 1/2 inch disk to 1.44 MB? Of course you have! It doesn't work! The computer gives an invalid media error. Our company was putting in a large network of IBM Clones. We have grown from a small company to a million-dollar corporation in two short years, and we didn't do it by wasting money. So, of course, we tried to use the cheap, 720K disks. Total failure.

ENTER OUR CRACKPOT ENGINEER. Our Crackpot Engineer wondered what was the difference between the disks. He tore them apart, analyzed the media. He found NO DIFFERENCE WHATSOEVER! Yet, they would not format. Why? Then he started examining the plastic housing. And he found the difference. It is NOT in the media, IT IS IN THE PLASTIC CASE!

TOTAL FAILURE! Our Crackpot Engineer (among other things, he invented the Electronic Flea Collar) sent a brand-new 720K disk to our machine shop, and asked them to modify it. They did... and the DISK IMMEDIATELY FORMATTED! But, within 10 minutes of use, it totally failed. It lost data all over the place. Back to the drawing board. The disk was dis-assembled and examined. It was found that, in performing the conversion, a microscopic piece of plastic had entered the housing, and totally ruined the disk. It was obvious that, if the conversion could be done reliably, it required extreme precision.

ENTER OUR OTHER CRACKPOT ENGINEER. Our president is a mechanical engineer. One of the best in the country. While a research scientist at Colorado School of Mines, he completely revolutionized the field of water jet drilling. He tackled the problem. Finally he came up with a solution - a precision tool which could perform the modification EVERY TIME and leave no plastic particles which would damage the disk!

MONTHS OF TESTING. We then commenced on a testing program. We modified and formatted thousands of disks, and tested them for data integrity. Out of one thousand disks, one would not format, two had one bad track. NOT ONE LOST ANY DATA! We then put a disk on a computer with a bat file which copied data to a disk, read and checked every byte, then copied the data back to the disk. The program ran 24 hours a day, for TWO SOLID WEEKS without even one error! We were finally convinced that the procedure was reliable enough for a product.

OUR OFFER. Here is our irresistible offer. Purchase our DoubleDisk Converter for the price of \$39.95. If you are not COMPLETELY SATISFIED, return the DoubleDisk. You will receive a FULL REFUND! What is more, if a disk ever does not convert properly, send us the disk, and we will send you a 1.44MB disk from a major manufacturer in exchange!

YOU CAN'T LOSE! You will save MORE THAN THE PURCHASE PRICE IN CONVERTING ONLY YOUR FIRST TEN DISKS! From that point on, it is all profit. After converting only 100 disks, and after deducting the cost of the DoubleDisk, you will have saved AT LEAST \$425.00! Quite a return for an investment of only \$39.95!

CREDIT CARDS AND CHECKS ACCEPTED! Purchasing our DoubleDisk is easy! Simply call our 800 number. We accept all major credit cards. Or, return the coupon below, and we will ship you one immediately. We Will gladly accept your personal check.

24 HOURS **ORDER TOLL FREE — 1-800-537-4226** 7 DAYS
(In Colorado call 303-872-8945)

YES! I want to try your DoubleDisk on your UNCONDITIONAL MONEY BACK GUARANTEE! I enclose only \$39.95 plus \$3.50 Shipping and Handling (California residents add \$2.40 Sales Tax) for each DoubleDisk Converter. If I am not COMPLETELY SATISFIED, I will return the DoubleDisk for a FULL REFUND! If any disk ever fails to convert, I will send it to you and you will IMMEDIATELY send me a 1.44MB Disk in exchange!

Name _____ Address _____
City _____ State _____ Zip _____ Telephone _____
Send To: Biological Engineering, Inc., DoubleDisk Offer
2674 Main Street, Ventura, CA 93003 Phone 805-644-1797

NO ADDED CHARGE ON CREDIT CARDS

EXECUTIVE PHOTO & SUPPLY CORP.

HOURS: Mon. Tru. Thurs. 9AM Till 6PM, Fri. 9AM Till 1:30PM, Sun. 9:30AM Till 5PM, Closed On Sat.

FOR COMPUTER & ACCESSORIES

CALL TOLL FREE: 1-800-882-2802
FOR FAX, TYPEWRITERS & DICTATION EQUIPT.
CALL TOLL FREE: 1-800-223-7323
IN N.Y. STATE CALL: 1-212-947-5290

LAPTOPS



SPARK BY DATAVIEW
SPARK-EL
640K, 2-3.5 720K Disk Drives,
1049.90

New! DATAVIEW SPARK 1-Floppy Drive, & 1-20MB Hard Drive.....1769.95

MITSUBISHI

268L w/20MB Hard Drive.....2359.00
268L w/40MB Hard Drive.....CALL

EPSON

EQUITY LT w/2-Drives, Backlit Screen & Laplink Plus.....1045.00
EQUITY LT w/20MB Hard Drive.1685.00

TOSHIBA (sold in Store Only)

TOSHIBA T-1000.....CALL
TOSHIBA T-1200/FB.....CALL
TOSHIBA T-1200HB.....CALL
NEW! TOSHIBA T-1600.....CALL
NEW! TOSHIBA T-3100E.....CALL
TOSHIBA T-3200/T-5100.....CALL

ZENITH

ZENITH 184-1.....Special 1439.00
ZENITH 184-2.....2199.75
ZENITH Supersport 286 Model 20 w/20MB Hard Drive.....2965.75
ZENITH 286 w/40MB Hard Drive.3399.75

NEC

NEC Multispeed HD.....LOW PRICE

AMSTRAD

AMSTRAD Laptop, 640K, 2-720K Drives, 2400 Baud Modem, AT Type Keyboard & Case.....799.00

DESKTOPS



COMPAQ
DESKPRO 286, 12MHz, 1.2 Floppy Drive, Seagate 40MB Hard Drive (40ms)2065.00
NEW! COMPAQ SLT/286 Portable w/40MB Hard Drive.....4359.00



AST RESEARCH INC.
AST PREMIUM 286
10 MHz, 512K, 1.2 Floppy Drive, Seagate 40MB Hard Drive (40ms)
1709.90

NEW! AST 386C w/64K Cache Memory, 20 MHz, 1MB Ram, 1.2 Floppy Drive, 40MB Hard Drive (28ms).....3199.00

COMPATIBLES

IBM-XT Compatible, 1-360 Floppy Drive, 1-30MB Hard Drive.....734.95
IBM-AT Compatible, 12MHz, 512K, 1.2 Floppy Drive, Seagate 40MB Hard Drive (28ms).....1305.00

LAPTOP ACCESSORIES

WORLD PORT 2400 Modem/Fax. CALL
Diconix Portable Printer.....304.90
CAMBRIDGE Z-88 Portable.....449.00

PRINTERS



EPSON
LQ-500
24 Pin, Narrow Carriage
180 CPS Draft, 60 CPS NLQ,
Tractor Feed Included
259.75*

EPSON LX-800.....170.99
EPSON EX-800.....369.75
EPSON LQ-850.....479.95*
EPSON LQ-950.....489.00*
EPSON LQ-1050.....635.75*
EPSON FX-850.....339.95
EPSON FX-1050.....449.95

PANASONIC

PANASONIC 1191.....235.75
NEW! PANASONIC 1181.....175.75
PANASONIC 1124.....Low Price

TOSHIBA (Sold In Store Only)

NEW! TOSHIBA Expresswriter 311. CALL
NEW! TOSHIBA 321SL Color.....CALL
TOSHIBA 341SL.....CALL
TOSHIBA 351 SX.....CALL

NEC

NEC 2200.....339.00
NEC P5200.....509.75
NEC P5300.....664.75

PRINTER SALE!

H.P. Laserjet II w/Toner.....CALL
STAR NX-1000.....169.95
APPLE Imagewriter II.....439.00

HARDWARE

intel
INTEL 80287-8.....205.00
NEW! INTEL Above Board Plus.....396.00
NEW! INTEL Visual Edge.....CALL
NEW! Logitech Mouse.....CALL
Logitech Clear Mouse.....69.95
DFI HS-3000 Scanner.....189.00
STB VGA Extra.....179.95
NEW! PARADISE VGA Plus 16.....299.90
MICROSOFT Mouse.....99.95
NEW! NEC Multisync IIA Monitor.499.95
ZENITH Perfect Monitor.....CALL
SONY 1302 Monitor w/Stand.....669.00
PLUS 20MB Card.....LOW PRICE
TOSHIBA 3 1/2" Drive w/Kit.....89.00

SOFTWARE

NEW! SAMNA AMI.....97.75
NEW! GEM Artline.....269.75
XY Write w/AI A Carte.....215.95
ASK SAM.....165.00
BITSREAM Fonts.....CALL
XEROX Ventura Publisher 2.0 Low Price
ADOBE Illustrator.....345.00
PROCAM Plus.....42.95
MICROSOFT Excel 2.1.....225.00
PFS First Publisher.....69.00
NOTA BENE 3.0.....248.50
LUICAD 3D Plus.....CALL
Q & A.....CALL
INTUIT Quicken.....31.95
MANAGING Your Money 5.0.....115.95
CHIPSOFT Turbo Tax.....42.79
DAC Easy Accounting 3.0.....57.00
NOLO Will Maker.....30.95
SPINRITE.....48.99
FASTRAX.....32.95
386 MAX.....54.75

FAX MACHINES



PANAFAX
UF-140.....CALL UF-150.IN STOCK
UF-250.IN STOCK UF-260.IN STOCK

SHARP

FO-220.....CALL FO-300.....CALL
FO-420.....CALL FO-550.....CALL
FO-700.....CALL FO-800.....CALL

CANON FaxPhones

FaxPhone 8.CALL FaxPhone 15.CALL
FaxPhone 20.CALL FaxPhone 25.CALL
FAX 1100.....CALL FAX 270.....CALL
FAX350.....CALL FAX 630.....CALL
FAX 705.....CALL

RICOH

FAX-20E.....CALL FAX-35.....CALL
FAX-60E.....CALL FAX-70E.....CALL

MURATA

M-1200.....659.90 M-1600.....769.90

PANASONIC

KX-F 100.....CALL KX-F 120.....CALL

TOSHIBA Price Break

3300.....999.90 3700.....1299.90
Model 30100.....839.90

SANYO

515H.....IN STOCK SF-200.IN STOCK

BROTHER

FAX w/Answering Machine.....759.90

FAX PAPER

8 1/2"x98".....49.95 8 1/2"x164".....59.90
8 1/2"x328".....74.95
FAX Cleaning Kit.....29.95

TYPEWRITERS & Word Processors



SMITH CORONA

PWP-60.....469.90
PWP-40.IN STOCK PWP-80.IN STOCK
NEW! PWP-100.....IN STOCK
XL-1000 Typewriter.....Special 119.90
XL-2500.....CALL XD-5500.....CALL
XD-7500.....CALL XD-9500.....CALL

PANASONIC

KX-W 1500 Word Processor..IN STOCK
KX-R 320.....CALL KX-R 330.....CALL
KX-R 340.....184.90 KX-R 350.....219.90



BROTHER
WP-55 Word Processor.....IN STOCK*
NEW! WP-490.....CALL
AX-26.....CALL AX-28.....CALL

*Free Spreadsheet Program w/Purchase of WP-55 Word Processor

Dictation Equipmt.



OLYMPUS Pearlcarder

L-200.....129.90 S-907.....35.90
S-911.....59.90 S-930.....99.90
T-1010 Transcriber.....169.90
S-804.....CALL S-810.....CALL
T2000.....CALL T-2020.....CALL

PANASONIC

RN-15.....129.90 RN-36.....179.90
RN-89.....79.90 RN-105.....29.90
RN-115.....39.90 RN-125.....53.90
RR-900.....179.90 RR-970.....249.90
RR-980.....279.90

SANYO

TRC-6100.....CALL TRC-5680.....79.90
TRC-2550.....149.90
TRC-5200.....229.90 TRC-5020.....179.90
TRC-4100.....227.90 TRC-4141.....178.90
TRC-8000A.....227.90 TRC-8010A.....165.90
TRC-8700.....239.90 TRC-8070.....185.90
TRC-9100.....239.90 TRC-9010.....199.90

SONY

M-100B.....219.90 M-740.....35.90
M-750V.....49.90 TCM-5000EV.369.90
BM-12.....CALL BM-17.....CALL
BM-560.....CALL BI-500.....CALL
BM-75.....CALL BM-80.....CALL
BM-815T.....CALL BM-820.....CALL

NORELCO

585.....89.90 590.....119.90
505.....299.90 510.....374.90
2505.....259.90 MC-4000.....349.90

COPIERS



Canon PC-3
PERSONAL COPIERS

PC-3.....349.90 PC-5.....CALL
PC-5L Legal Size.....529.90
PC-6.....CALL PC-6RE.....CALL
NEW! PC-7 Zoom Copier.....909.90
Black Cartridges.....79.95
8 1/2"x11 Paper (5000 sheets).....49.50

TELEPHONES

Panasonic
Answering Machines Specials
KX-T 1412.....59.90 KX-T 1418.....69.90
KX-T 1423.....65.90 KX-T 1424.....69.90
KX-T 1427 LCD w/Time Announce.109.90
KX-T 1600.....69.90 KX-T 1720.....109.90
CORDLESS PHONES
KX-T 3000.....119.90 KX-T 3807.....59.90
KX-T 3824.....89.90 KX-T 3880.....125.90
KX-T 4200 w/Answering Machine.145.90
Freedom Phone
FF-1700 Cordless "Top Rated".....109.90

DATABANKS

PSION
ORGANISER II-XP.....198.90
SHARP
OZ-7000 WIZARD.....IN STOCK
EL-6250H Dial Master.....53.90
CASIO
CASIO SF-3000 18K.....69.90
CASIO SF-4000 32K.....79.90

VISA, MASTERCARD, AMERICAN EXPRESS, OPTIMA & DISCOVER CARDS ACCEPTED

OUR GUARANTEE: Defective goods will be replaced or repaired if returned within 10 Days in original packing, mint condition, blank warranty card, detailed letter of explanation & copy of invoice. No return privilege on software. If found defective, We will advise customer how to consult manufacturer for warrantee service. For Customer Service: Please Call (212) 947-5295. Not Responsible for typographical errors. We reserve the right to limit quantities.

TO ORDER by MAIL: Please send money order or certified check for UPS shipment on most items. Personal check delays your order by 15 days.
Shipping & Handling: Handling Charge; 2% plus 5.95. Shipping Charge; 0.65 per lb. Estimate minimum shipping 5.95. Total charge at time of order. Shipping & Handling charges are not refundable.
INQUIRE about NEXT DAY AIR or 2nd DAY AIR Shipment. N.Y. State Residents add TAX.

EXECUTIVE PHOTO & SUPPLY CORP.

MAIL ORDER: Dept BY,120 West 31st Street, N.Y.,N.Y. 10001 (Tel. 1-212-947-5290)
MANHATTAN STORE: 120 West 31st. Street, N.Y.,N.Y. 10001 (Tel. 1-212-564-3592)
SCARSDALE, NY STORE: 455 Central Ave. (Scarsdale Plaza) SCARSDALE,N.Y. 10538 (Tel. 1-914-723-1331)
N.Y.C. Consumer Affairs License Number: 800193
Circle 95 on Reader Service Card

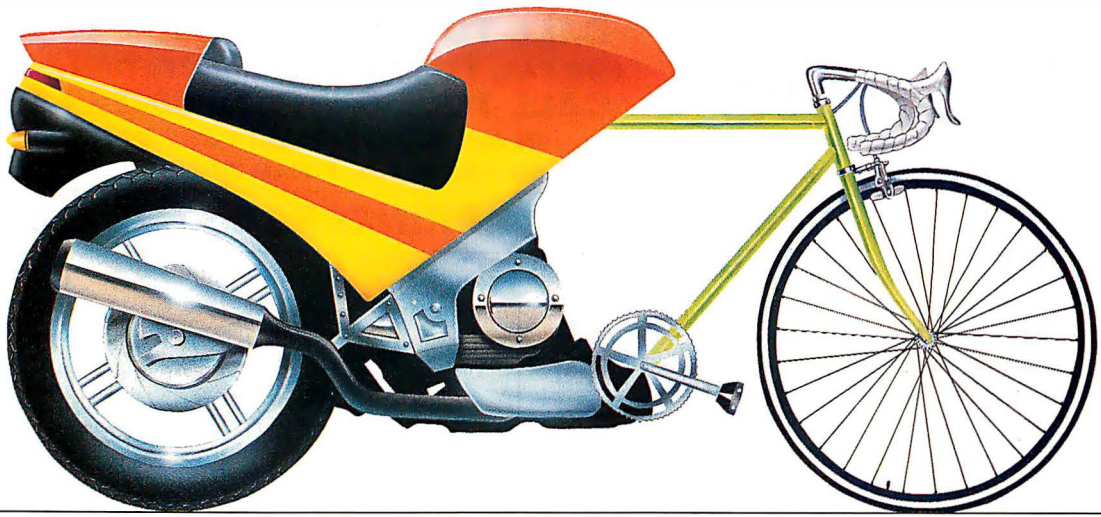

Pack extra power into your PC.

Make it over into a '386.

DTK's new PEM-2000 dual-speed 8/20 MHz 80386 motherboard gives you 100% PC/AT compatibility at speeds up to 27.3 MHz. It also offers some very elegant engineering, like eight expansion slots including two for 32-bit memory expansion, two serial ports and one parallel port, a DTK BIOS with built-in diagnostics, and the socket for an optional 80387 coprocessor.

DTK means value in PC-compatible motherboards, add-on and networking cards, and bare bone systems, including FCC Class B-certified 10 and 12 MHz '286 computers. Which is why the two high-speed XT clones named "Best Buys" in *PC World's* August, 1988 issue, both use DTK motherboards.

The PEM-2000 is a good example—but by no means the only example—of the DTK difference. To get the full story on all our high-performance XT, '286 and '386-based products, contact the DTK office nearest you for specifications and pricing.

And find out how to pack some extra power into your PC.

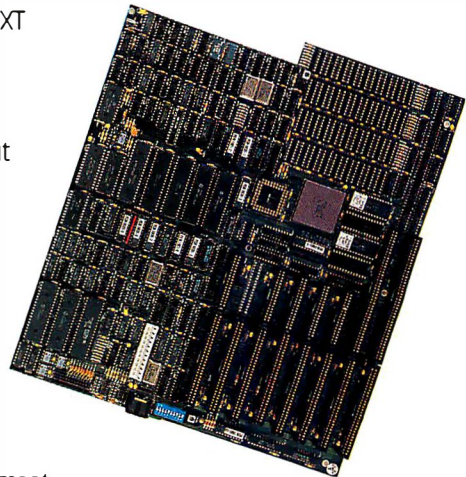

® Where price and performance meet.

DTK COMPUTER INC.

15711 E. Valley Blvd. • City of Industry, CA 91744
Tel: (818) 333-7533 • Fax: (818) 333-5429

DTK Computer Inc. of Florida
7245 Corporate Center Dr., Suite B
Miami, FL 33126
Tel: (305) 477-7440
Fax: (305) 477-8322

DTK Computer Inc. of New Jersey
300 Columbus Circle, Raritan Center
Edison, NJ 08818
Tel: (201) 417-0300
Fax: (201) 417-0307

DTK Computer Inc. of Texas
10535 Wilcrest Dr., Suite 120
Houston, TX 77099
Tel: (713) 568-6688
Fax: (713) 568-5688

EXCLUSIVE DISTRIBUTORS:
Florida: TWC (305) 599-0871
Northern California: Supercom
(415) 770-1100
San Diego: Nimax
(619) 566-4800

DTK Computer GmbH
Wahlerstr. 16
4000 Dusseldorf 30
West Germany
Tel: (0211) 656031
Fax: (0211) 653753

AT and XT are registered trademarks of International Business Machines Corporation. DTK is a registered trademark of Datatech Enterprises Co., Ltd.



High-Tech Computing, Cafeteria Style

The Wells American CompuStar 286 packs performance into a design-it-yourself PC

Mark L. Van Name

When it comes to PC engineering, "new" usually means bigger or faster: faster processors, bigger and faster memory caches, bigger and faster hard disk drives. That's why it's nice to see a computer like the Wells American CompuStar 286—a machine that tries something new.

What's new about the CompuStar is that it's the first computer designed to be whatever kind of PC you want. Want an AT clone? The CompuStar can be an AT clone. How about a Micro Channel system—a PS/2 clone? It can be that, too. You can even have both types of PCs in the same box.

You pick your processor, too. You can choose an 8086, a fast 20-MHz 80286, or three different models (16-, 20-, and 25-MHz) of the 80386.

The Secret

The secret to this flexibility is a unique design. The CompuStar base system includes a keyboard and an almost-empty shell: a 24- by 7½- by 26-inch, floor-standing, aluminum-skinned case housing just a 220-watt power supply and what Wells American calls its I/O module. The I/O module supplies two serial ports, one parallel port, PS/2-style 6-pin DIN keyboard and mouse connectors, and both a DB-9 digital monitor connector and a DB-15 VGA analog connector.



Circuitry on the I/O module handles VGA (courtesy of a Paradise PVGA1A chip), EGA, CGA, MDA, and Hercules graphics. This board also acts as a disk drive controller that can handle up to four floppy disk drives.

After you order the \$1195 base system, you then choose from a list of options. You start with a bus module. You can pick an AT- or PS/2 Micro Channel-compatible bus module; if you choose the PS/2 bus module, you also need a special PS/2 adapter. The AT bus module has seven AT-compatible expansion slots, while the PS/2 module contains five Micro Channel-compatible slots and one AT-compatible slot. Since the only card you need to add to most CompuStar basic systems is a hard disk drive controller, you end up with a lot of free slots.

And there's more. You can have not one, but two bus modules—a primary

and a secondary. You can mix and match these any way you want: two AT bus modules, two PS/2 bus modules, or one of each. So, in a single CompuStar chassis, you can have up to 13 AT slots, or 10 PS/2 slots and one AT slot, or a mixed bag of seven AT slots and five PS/2 slots. Talk about expansion space!

After you pick a bus module, you then need to choose a processor, or, in Wells American's terms, a CPU module, which contains a CPU, a socket for a math coprocessor, memory sockets, the ROM BIOS, sockets for two expansion ROM chips, and a battery-backed clock/calendar. Wells American is shipping the 80286 and both 16- and 20-MHz 80386 CPU modules. A company spokesperson said that the 10-MHz 8086 CPU module was scheduled to begin shipping in February.

continued

Wells American also offers a nifty CPU upgrade option. You can trade in your initial CPU module for another and get a purchase credit toward the cost of the new one. In fact, if you trade in your CPU module within a year after purchase, the company gives you its full purchase price as a credit.

The combination of the bus and CPU modules still doesn't give you a complete system. While the 8086 CPU module comes with 512K bytes of memory, the 80286 and 80386 CPU modules do not include any memory. You purchase separately either 512K-byte or 1-megabyte memory modules from Wells American. These memory modules are 80-nanosecond DRAM zig-zag in-line packages (ZIPs) that plug into the eight ZIP sockets on the CPU modules. You can add a 1-megabyte memory-expansion kit to the 1-megabyte memory modules, so, with eight such expanded modules, you can rev your CompuStar up to its maximum 16 megabytes of memory.

Finally, you must add the other neces-

sities: one or more floppy disk drives, one or more hard disk drives, a monitor, and DOS.

This process sounds like a lot of work, but fortunately Wells American sends the system to you fully assembled, with the hard disk drive formatted and ready to go.

A Cautionary Note

If the CompuStar's flexibility, and especially its dual-bus option, seem too good to be true, you're not alone. I felt the same way. I'm still not sure it will all materialize, because as we go to press, Wells American is not yet shipping any of the PS/2 modules, and the company did not get an 80386 CPU module to BYTE in time for this review because it was only recently completed. A spokesperson said that the PS/2 modules were ready, but that Wells would not ship them until it had secured some patents it was seeking. The company projects that it will ship the PS/2 modules in the first quarter of this year.

Despite the unavailability of some modules, this machine shows some of the nicest engineering I have seen in a long time. Although Wells American isn't a household name, the company has been around for some time. In the late 1970s and early 1980s, it built microcomputers under the name of Intertec Data Systems, which you may remember for its SuperBrain CP/M microcomputers and its later multiuser systems.

The Evaluation System

My evaluation system came with one AT-compatible bus module, the 20-MHz 80286 CPU module, a 10-MHz 80287 math coprocessor, 1 megabyte of 80-ns DRAM in two 512K-byte ZIPs, two 1.44-megabyte 3½-inch floppy disk drives, one 1.2-megabyte 5¼-inch floppy disk drive, a 150-megabyte hard disk drive, a flat-tension-mask VGA color monitor, and IBM's PC-DOS 3.3. Six of the AT slots were empty, with the hard disk drive controller in the seventh slot (see photo 1).

That's a powerful system, and it carries a hefty price tag: \$6570. But you get a lot of performance for the money. In fact, this CompuStar 286 proved to be the fastest 80286-based system that BYTE has tested. Its overall application index was about 9 percent faster than that of the previous 80286 speed champ, the Dell System 220. The CompuStar beat the Dell System 220 on all but the word processing and compiler tests, which it lost by only 3 percent and 2 percent, respectively.

Both systems maximize their performance with interleaved memory banks, so that one bank of memory recharges while the other is ready to go. As you might expect from such a well-engineered machine, the CompuStar offers a nice improvement on traditional two-bank interleaving: If you have four identical memory modules, it can do four-way interleaving, so that three banks are ready while one is recharging. On its 80386-based CPU modules, Wells American combines this interleaving with an Intel 82385 cache controller and 32K bytes of 35-ns static RAM cache to boost performance further.

Wells also borrows a page from most 80386-based systems for the CompuStar 286 by using shadow RAM, a technique that copies the ROM BIOS into RAM at boot time for faster ROM access.

The flip side of performance is always price, and the CompuStar's speed victory over the Dell System 220 would mean a lot less if the CompuStar cost a

continued

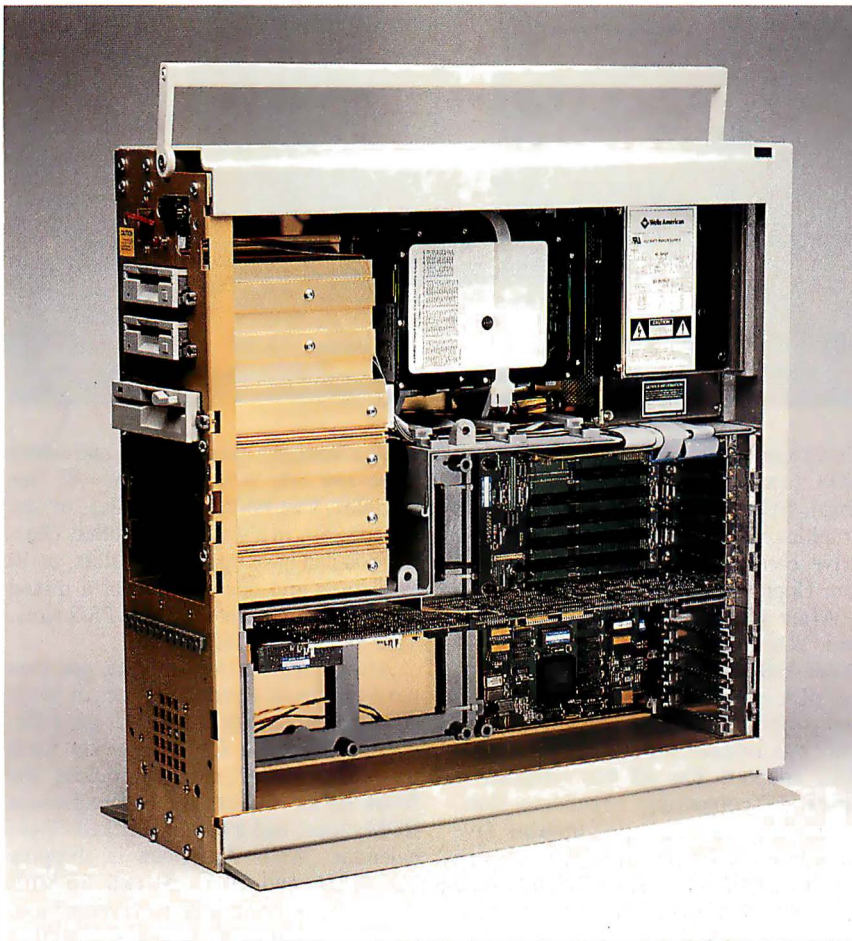
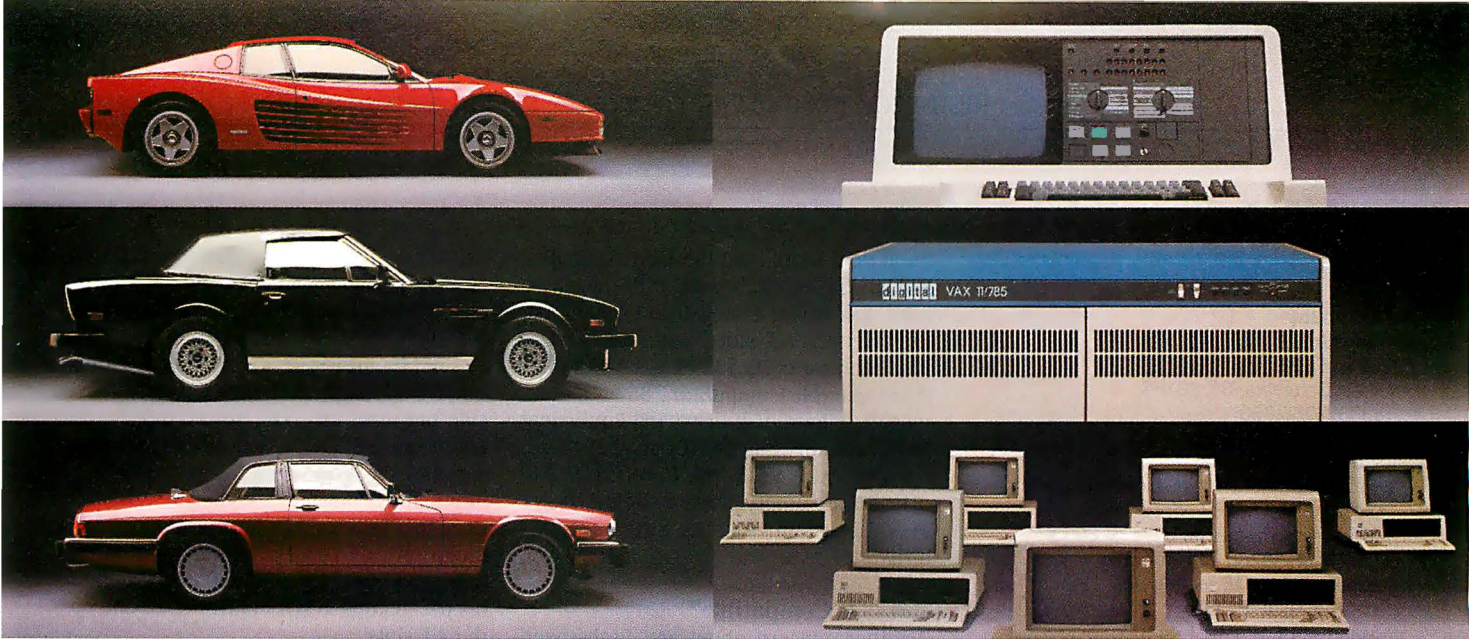

Photo 1: The inside of the CompuStar reveals the nature of the beast: plenty of expansion room and easy access to components.



Use Premium Fuel Only.

Ditto.

Take ½ gallon of gasoline formulated for high-performance motor cars.

Add a clod of dirt, a quart of kerosene, a tablespoon of sugar, and a dollop of axle grease. Sprinkle with rust particles and dog hairs. Stir.

You'd be *crazy* to put *that* in your Ferrari, right?

But what we've just concocted is the petroleum equivalent of a kilowatt of ordinary electricity.

Emerson UPS's Provide Clean Fuel For Computers.

Since today's computers are no less high performance machines than the most sophisticated automobiles, they need highly-refined fuel, too.

An Emerson Uninterruptible Power Source is the *electrical* equivalent of a petroleum refinery. Raw fuel in, good fuel out.

Such a simple solution to all the harm spikes, sags, and blackouts can do.

Unrefined Electricity Does Crude Things To Computers.

Unlike bandsaws, washing machines and tv's, computer circuits are hypersensitive to the slightest power variations. Data can be scrambled or vaporized in a few milliseconds. Programs can crash unceremoniously.

Fact is, many problems blamed on hardware or software are, in reality, the fault of raw electricity. Industry statistics show that half the downtime, lost employee and machine productivity, and maintenance costs are the direct result of bad electricity.

A typical computer site experiences about 7 blackouts, over 500 sags and more than 2,000 spikes and surges per year. Plus there's almost continuous line noise at even the best locations.

Power surges alone are credited by one insurance company with \$35 million in pc losses just last year.

Any way you look at it, making sure your computer gets premium fuel is up to you. Fortunately, it's easy and affordable.

UPS Performance And Throughput.

Most people think of Emerson UPS systems as just battery backup

protection against power outages.

In reality, they're also the best power *conditioners* money can buy. They work *continuously*, uniquely providing an impenetrable barrier that isolates your computers from power problems.

The result: You get the level of performance your computer was designed to deliver. The level you paid for.

The High Performance UPS Manufacturer.

Emerson makes a full line of UPS, power conditioning and distribution systems, even simple surge protectors.

All feature quiet operation, attractive design, UL-listed safety, operation that is one-switch simple, and proven reliability backed by the best service in the business.

So, let us help you rev up your productivity. **Simply call 1-800-BACK-UPS** for our free introductory brochure and the name of your local representative. Or write: Emerson Computer Power, 3300 S. Standard St., Santa Ana, CA 92702.

EMERSON
Computer Power

Computers Won't Run Right
On The Wrong Fuel.



CompuStar 286**Company**

Wells American Corp.
3243 Sunset Blvd.
West Columbia, SC 29169
(803) 796-7800

Components

Processor: 20-MHz 16-bit Intel 80286;
10-MHz Intel 80287 coprocessor
Memory: 1 megabyte of 16-bit 80-ns
DRAM on 80286 CPU module,
expandable to 16 megabytes; 128K
bytes of BIOS ROM
Mass storage: Two 1.44-megabyte 3½-
inch floppy disk drives; one 1.2-megabyte
5¼-inch floppy disk drive; 150-
megabyte hard disk drive
Display: Flat-tension-mask color VGA-
compatible monitor; VGA support on the
motherboard
Keyboard: 101 keys in IBM Enhanced
layout
I/O interfaces: Two RS-232C serial
ports; DB-25 parallel port; analog monitor
port with DB-15 connector; 6-pin DIN
keyboard connector; 6-pin DIN mouse
connector; seven AT-compatible
expansion slots

Size

24 × 7½ × 26 inches; 66 pounds
(weight can range from 50 to 90 pounds,
depending on the configuration)

Software

Setup disk, which includes a setup
utility, a memory and port management
utility, a video mode utility, a utility for
setting the processor's speed, utilities for
displaying messages on the LED
display, and drivers for LIM/EMS memory
and additional floppy disk drives

Options

CompuStar Base Model 100: \$1195
AT-compatible primary bus module:
\$195
AT-compatible secondary bus module:
\$175
PS/2-compatible primary bus module:
\$295
PS/2-compatible secondary bus
module: \$250
PS/2 adapter module: \$995
8086 CPU module (available as of
February): \$295
80286 CPU module: \$695
80286 memory-extender kit: \$55
16-MHz 80386 CPU module: \$1395
20-MHz 80386 CPU module: \$1695

Documentation

User's manual; Adaptec hard disk drive
controller user's manual

Price

System as reviewed: \$6570

Inquiry 857.

great deal more than the Dell computer. A Dell System 220 with a 40-megabyte hard disk drive, 1 megabyte of memory, three empty AT slots, and Dell's VGA Plus monitor costs \$3299 as I write this. A comparable CompuStar 286 with a 44-megabyte hard disk drive and equivalent VGA monitor runs \$4010, or \$711 more. For that extra \$711, the CompuStar 286 offers more empty slots, a slightly faster overall system, and its built-in flexibility.

But Is It Compatible?

Another concern about any high-speed PC is its level of compatibility. The CompuStar ran everything I threw at it, both hardware and software. I successfully installed an Everex Evercom II 2400-bps internal modem, a Microsoft Serial Mouse, and an Intel Above Board/AT. On the software side, I tested Borland's Quattro 1.0, Reflex 1.14, SideKick Plus 1.0, SuperKey 1.16A, Turbo Basic 1.1, Turbo C 2.0, and Turbo Pascal 4.0; Digitialk's Smalltalk/V 1.2; Kermit 2.30; Lotus 1-2-3 version 2.01, which ran without forcing me to slow the system manually; MicroPro's WordStar 3.3 and 4.0; Microsoft's PC Paintbrush 2.0 and Word 4.0; Quarterdeck Office Systems' DESQview 2.0; the Norton Utilities 3.00; and Symantec's Q&A 1.1.

Wells American sells IBM's own PC-DOS 3.3 and the AT version of IBM's OS/2 1.00, which a Wells spokesperson said runs on the CompuStar. Wells did not include OS/2 with the evaluation unit, however, so I was unable to verify that.

And More Goodies

When you leave the world of external applications and dive into the box itself, you find that the Wells engineers have been at it again. It starts with the fans—one at the bottom front of the unit that blows out enough air that you can feel it if you wear shorts, and one at the top rear inside the power display case. The unit disassembles easily, using Nylatch nylon snap fasteners.

The flexible design also extends to the CompuStar's storage devices: The system can hold up to six half-height devices, all of which you can access from outside the machine, if necessary. Two of these device areas are 3½-inch bays, while the other four can hold 5¼-inch devices. All the devices mount on sliding rails inside the machine.

My evaluation unit had two Mitsubishi 3½-inch floppy disk drives, which DOS saw as drives A and B, in the 3½-inch slots. By using Wells's own special

drivers and CompuStar Extended Diskette Drive BIOS, DOS saw my evaluation unit's third floppy drive, a 1.2-megabyte 5¼-inch TEAC model, as drive E.

The CompuStar also includes one other full-height 5¼-inch drive bay inside the machine. The power supply includes seven device connectors, so you can run the system even if you fill this bay and all six half-height bays. In my unit, this internal bay held a Maxtor 155-megabyte, 18-millisecond hard disk drive managed by an Adaptec 10-mega-bit-per-second ESDI controller in one of the AT slots.

Wells American includes Storage Dimensions' well-respected SpeedStor hard disk device driver, version 5.13b, with the system. The combination of that software and Wells's disk BIOS lets you make a second DOS partition that is larger than the traditional DOS 3.3 limit of 32 megabytes. In my evaluation unit, the C drive was only 2 megabytes, while the D drive was over 150 megabytes. Wells American uses this design to leave drives E and F open for two of the four floppy disk drives that the CompuStar can include.

Wells also offers a slew of other mass storage options, including tape backup systems, a WORM (write once, read many times) drive, and an erasable optical drive from Maxtor.

The CompuStar's interior bay design has one flaw: No hard disk light is visible outside the machine. Wells more than compensates for this omission, however, with a little touch that Dell popularized on its early systems: a four-character LED display on the front of the system. That display shows both diagnostic and system status information. For example, it shows "R" when the system is reading the hard disk and "W" when the system is writing to that disk. If you press the Control or Shift keys, the LED shows the current system speed.

Wells American also includes on its standard setup disk two programs, DISP.EXE and SCROLL.EXE, with which you can display four characters of your choice, either statically or scrolling from right to left, in the LED display.

Wells American also did its own ROM BIOS; my unit included the CompuStar Multi-Processor Convertible Microcomputer V1.05 BIOS.

Like most of today's fastest systems, the CompuStar offers a slower compatibility speed. Unlike many systems, however, it offers five slower speeds. You can run the 80286 at 16, 12, 10, 8, or 6 MHz. Wells implements these speeds by

continued

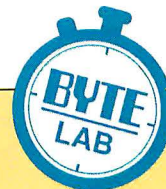

Wells American CompuStar 286

APPLICATION-LEVEL PERFORMANCE

Wells American CompuStar 286 **12.5***

WORD PROCESSING

XyWrite III+ 3.52	Medium/Large
Load (large)	:10
Word count	:03/:20
Search/replace	:05/:22
End of document	:02/:14
Block move	:09/:09
Spelling check	:09/1:00

Microsoft Word 4.0

Forward delete	:13
----------------	-----

Aldus PageMaker 1.0a

Load document	:13
Change/bold	:25
Align right	:20
Cut 10 pages	:18
Place graphic	:05
Print to file	1:46

Index: 2.62

SPREADSHEET

Lotus 1-2-3 2.01

Block copy	:03
Recalc	:01
Load Monte Carlo	:16
Recalc Monte Carlo	:04
Load rlarge3	:03
Recalc rlarge3	:01
Recalc Goal-seek	:03

Microsoft Excel 2.0

Fill right	:05
Undo fill	1:50
Recalc	:01
Load rlarge3	:25
Recalc rlarge3	:01

Index: 3.11

DATABASE

dBASE III+ 1.1	
Copy	:59
Index	:18
List	1:14
Append	1:34
Delete	:02
Pack	1:20
Count	:16
Sort	1:04

Index: 1.65

SCIENTIFIC/ENGINEERING

AutoCAD 2.52

Load SoftWest	1:09
Regen SoftWest	:44
Load StPauls	:11
Regen StPauls	:07
Hide/redraw	14:58

STATA 1.5

Graphics	:19
ANOVA	:14

MathCAD 2.0

IFS 800 pts.	:21
FFT/IFFT 1024 pts.	:22

Index: 3.06

COMPILERS

Microsoft C 5.0

XLisp compile	4:37
---------------	------

Turbo Pascal 4.0

Pascal S compile	:06
------------------	-----

Index: 2.06

All times are in minutes:seconds. Indexes show relative performance; for all indexes, an 8-MHz IBM PC AT=1.

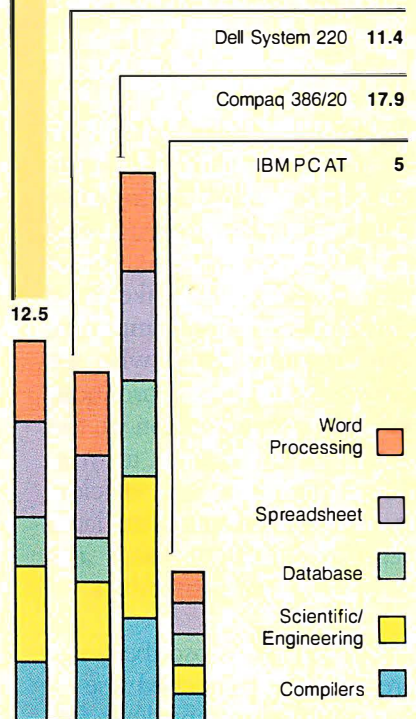

*Cumulative application index. Graphs are based on indexes at left and show relative performance.

LOW-LEVEL PERFORMANCE¹

Wells American CompuStar 286

CPU

Matrix	5.20
String Move	
Byte-wide	40.40
Word-wide:	
Odd-bnd.	30.60
Even-bnd.	20.19
Sieve	22.69
Sort	18.95

Index: 2.64

FLOATING POINT

Math	23.12
Error ²	
Sine(x)	9.78
Error	
e^x	8.37
Error	

Index: 2.04

DISK I/O

Hard Seek³	
Outer track	3.29
Inner track	3.33
Half platter	6.66
Full platter	6.68
Average	4.99

DOS Seek

1-sector	8.47
32-sector	25.19

File I/O⁴

Seek	0.11
Read	0.88
Write	0.78

1-megabyte

Write	4.87
Read	5.02

Index: 1.90

VIDEO

Text	
Mode 0	3.95
Mode 1	3.96
Mode 2	3.94
Mode 3	3.92
Mode 7	N/A

Graphics

CGA:	
Mode 4	1.92
Mode 5	1.87
Mode 6	2.01
EGA:	
Mode 13	3.46
Mode 14	3.74
Mode 15	N/A
Mode 16	3.77
VGA:	
Mode 18	3.90
Mode 19	2.00
Hercules	N/A

Index: 2.30

CONVENTIONAL BENCHMARKS

LINPACK	478.68
Livermore Loops ⁵	
(MFLOPS)	0.46
Dhrystone (MS C 5.0)	
(Dhry/sec)	5000

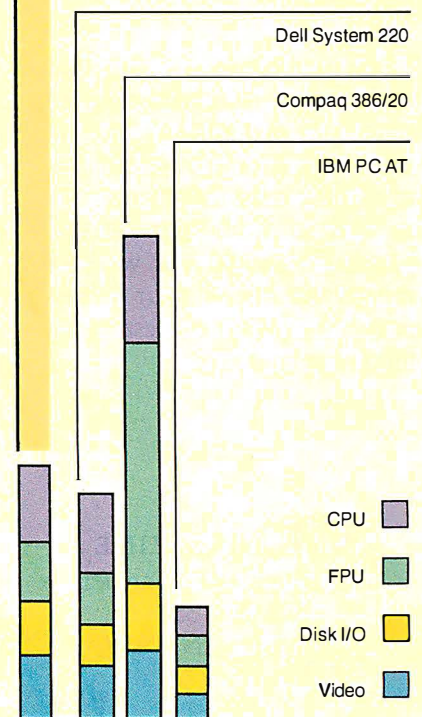

N/A=Not supported by graphics adapter.

¹ All times are in seconds. Figures were generated using the 8088/8086 versions (1.1) of Small-C.

² The errors for Floating Point indicate the difference between expected and actual values, correct to 10 digits or rounded to 2 digits.

³ Times reported by the Hard Seek and DOS Seek are for multiple seek operations (number of seeks performed currently set to 100).

⁴ Read and write times for File I/O are in seconds per 64K bytes.

⁵ For the Livermore Loops and Dhrystone tests only, higher numbers mean faster performance.

A MESSAGE TO OUR SUBSCRIBERS

FROM TIME TO TIME we make the BYTE subscriber list available to other companies who wish to send our subscribers material about their products. We take great care to screen these companies, choosing only those who are reputable, and whose products, services, or information we feel would be of interest to you. Direct mail is an efficient medium for presenting the latest personal computer goods and services to our subscribers.

Many BYTE subscribers appreciate this controlled use of our mailing list, and look forward to finding information of interest to them in the mail. Used are our subscribers' names and addresses only (no other information we may have is ever given).

While we believe the distribution of this information is of benefit to our subscribers, we firmly respect the wishes of any subscriber who does not want to receive such promotional literature. Should you wish to restrict the use of your name, simply send your request to the following address.

BYTE MAGAZINE

ATTN: SUBSCRIBER SERVICE
P.O. Box 555
HIGHTSTOWN, NJ 08520



using three different crystals/oscillators in the system, one each for the 20-, 16-, and 12-MHz rates. A flip-flop divider off the oscillators provides the three additional slower speeds. You can control the unit's speed from the keyboard with the now-traditional Ctrl/Alt/+ combination to raise the speed, or Ctrl/Alt/- to lower it. The system beeps once each time you lower its speed, and twice each time you raise the speed. You can also use a Wells utility, SPEED.EXE, to set the speed from the DOS command line.

Monitor and Keyboard

In keeping with this abundance of options, you can choose either a "firm touch" or "soft touch" keyboard. Both keyboards follow the IBM 101-key Enhanced layout. My evaluation unit came with the Fujitsu keyboard that is showing up on a lot of machines these days. It has a good, very springy feel with an audible keyclick.

As for the monitor—well, if you haven't seen flat-screen color monitors yet, avoid them at all cost. Once you see one, you'll want one, and they're expensive. Wells charges \$895 for the Zenith-built one on my evaluation unit, and it is gorgeous, albeit big and a bit noisy, since it has its own fan.

The Soft Side

The only standard software is Wells American's Setup disk, which comes in both 3½- and 5¼-inch versions. That disk includes Wells's setup program, which is also in ROM and accessible via the Ctrl/Esc key combination; a LIM/EMS driver; a program that lets you set the system's video mode; another that lets you control its port assignments and memory usage, including its use of interleaving and shadow RAM; Wells American's special disk drivers; and the LED and compatibility speed control programs mentioned earlier.

Documentation and Support

The CompuStar includes a single, 100-plus-page user's manual. Its early chapters are for novices, with step-by-step instructions for adding options to the system. Its later chapters and appendixes contain detailed technical information, including data on the jumpers on all the CPU modules.

Unfortunately, even though it's well done, this book just cannot make a novice comfortable installing all the possible options. The task itself is largely unnecessary, however, since Wells assembles the units at the factory.

My unit also came with a user's man-

ual for my Adaptec hard disk drive controller. That complex book is useful only for skilled users who want detailed information about the controller.

When the manuals leave you wanting, you can call the company's technical support. It's a toll call, which is unfortunate since you're likely to have to wait. Every time I called, I had to sit on hold until I either gave up or gave in to the secretary's request for my name and number. When she took that information, however, someone always called me back. The support people with whom I spoke were courteous and very knowledgeable about every aspect of the system. In a rare sweep of competence, everyone with whom I spoke was able to answer all my test questions, which ranged from simple to complex.

You get a one-year limited warranty on parts and labor, which includes all hardware but not software. You have to get your machine, or at least the defective component, to a Wells Authorized Warranty Repair Center. You can buy on-site service in many locations nationwide through Wells's arrangement with General Electric. Wells American sets prices for this service on a monthly basis by component, such as \$5 for the base system, \$3.50 for the 80286 CPU module, and \$26 for the 150-megabyte hard disk drive. Those prices can add up for a whole system; a year of service for my evaluation unit would run around \$700.

Wells offers another support plan, the C.A.R.E. (components authorized for repair or exchange) program, for which the company has not yet set prices. It lets you quickly replace a defective module. You call with the identity of the module, and the company will send a replacement via overnight delivery service.

A Good System with Great Potential

The CompuStar 286 is the fastest 80286-based system I've seen, and it has as much or more expansion capability as any system I've seen. Those properties, along with a bearable price tag, make it a good machine to consider. The real excitement will come if Wells American delivers its PS/2 module, fulfilling the dual-bus promise of the CompuStar.

I hope Wells meets this challenge, because I like this machine, and I like the engineering behind it. It's nice to see something new in the PC clone business for a change. ■

Mark L. Van Name is a freelance writer and computer consultant living in Durham, North Carolina. He can be reached on BIX/c/o "editors."

Each One Is A Landmark Of Power.
A Technical Masterpiece.
The Answer To A Specific Need.



AST makes the fastest and highest-quality desktop computers in the business world. One of them is right for you. Whether you need a personal computer for general office work, engineering, desktop publishing, financial analysis or running your business at home, you can count on AST to fit your desktop size, your budget and your need for ultimate speed.

INFO WORLD REPORT CARD		
AST Premium/286	CO MPAG DE SMPRO 386* 200	ISM* PS2* Model 80-111
8.0	7.5	6.5
Final Scores • 20 MHz 386-Based Computers May 2, 1988		

Our Newest Wonders. If you want extra performance and high quality without spending a lot of money, try our newest computers — the AST Premium® 386/16 and the AST Bravo/286. Our cache-based AST Premium 386/16 makes 386™-CPU computing available to even the most cost-conscious budget. And the AST Bravo/286 is all the AT®-compatible power you

need to manage your small business or home office, or use it as a node in a local area network.

Our Most Powerful Wonders. For high-speed CAD/CAM/CAE, multitasking, multiuser environments and LAN file service, choose AST's top performing systems. The 25 MHz AST Premium 386/25 and 20 MHz AST Premium/386C bring the highest performance to your sophisticated 386-CPU based applications.

Our Most Versatile Wonder. If you have to choose one computer that satisfies the broadest range of needs, let it be the AST Premium/286. Perfect for flying through word processing, large spreadsheets and even technical applications, it's the industry's award-winner for 286 performance and value.

Our Smallest Wonders. When your desktop space



*Source: PC Week, Nov. 14, 1988.

AST, AST logo and AST Premium registered trademarks AST Research, Inc. 80386 and 80386SX trademarks Intel Corp. AST markets products worldwide — in Europe and the Middle East call 44 1 568 4350; in Japan call 03-3344-1111.

AST Introduces The Best Of The Business



AST Bravo/286
Extra value, quality and AT-compatibility for business or home office use.

AST Premium Workstation/286
Executive styling and test-proven AT compatibility in a powerful 286 computer.

AST Premium/286
Outstanding, industry winner for general business and technical applications.

AST Premium 386/25
State-of-the-art solution for ultimate LAN file service and CAD/CAM/CAE.

is limited, but your appetite for speed and power isn't, the AST Premium Workstation/386SX and the AST Premium Workstation/286 offer test-proven compatibility you can rely on. These sleek, small-sized wonders are the quality answer to cost-effective, high-performance desktop computing.



AST Service, Support And Reliability — The Eighth Wonder. The AST logo means quality products and service. In fact, PC Week recently named AST first in technical support, over Compaq® and IBM®.*

For the products and service that will make you the next wonder of the world, ask for AST Computers. For more information, call (714) 863-0181 and ask for operator BB6, use our Bulletin Board Service number (714) 852-1872, or fill out the coupon.

Please send me information on AST computers. BYTE 4/89
 Please have an AST representative call me.
 I am an end user a reseller.
 Name _____
 Title _____
 Company _____
 Address _____
 City/State/Zip _____
 Phone _____
 AST Research, Inc. 2121 Alton, Irvine, CA 92714-4992. Attn: M.C.



Times Have Changed.

Other product and brand names are trademarks and registered trademarks of their respective companies. Copyright © 1989 AST Research, Inc. All rights reserved. 3 818 0710; in the Far East call our Hong Kong office 852 5 806 4333; in Canada call 416 826-7514.

**Circle 26 on Reader Service Card
(DEALERS: 27)**

The Seven Wonders of the Business World.



AST Premium/386C
 Multiuser, multitasking
 386-CPU powerhouse
 with integrated cache
 architecture.



AST Premium 386/16
 Cache-based, true 32-
 bit, 386 CPU processing
 for sophisticated, yet
 affordable computing.



**AST Premium
 Workstation/386SX**
 Executive styling
 in a cost-effective,
 entry-level 386-
 CPU system.

GENIUS MOUSE TAKES EUROPE BY STORM

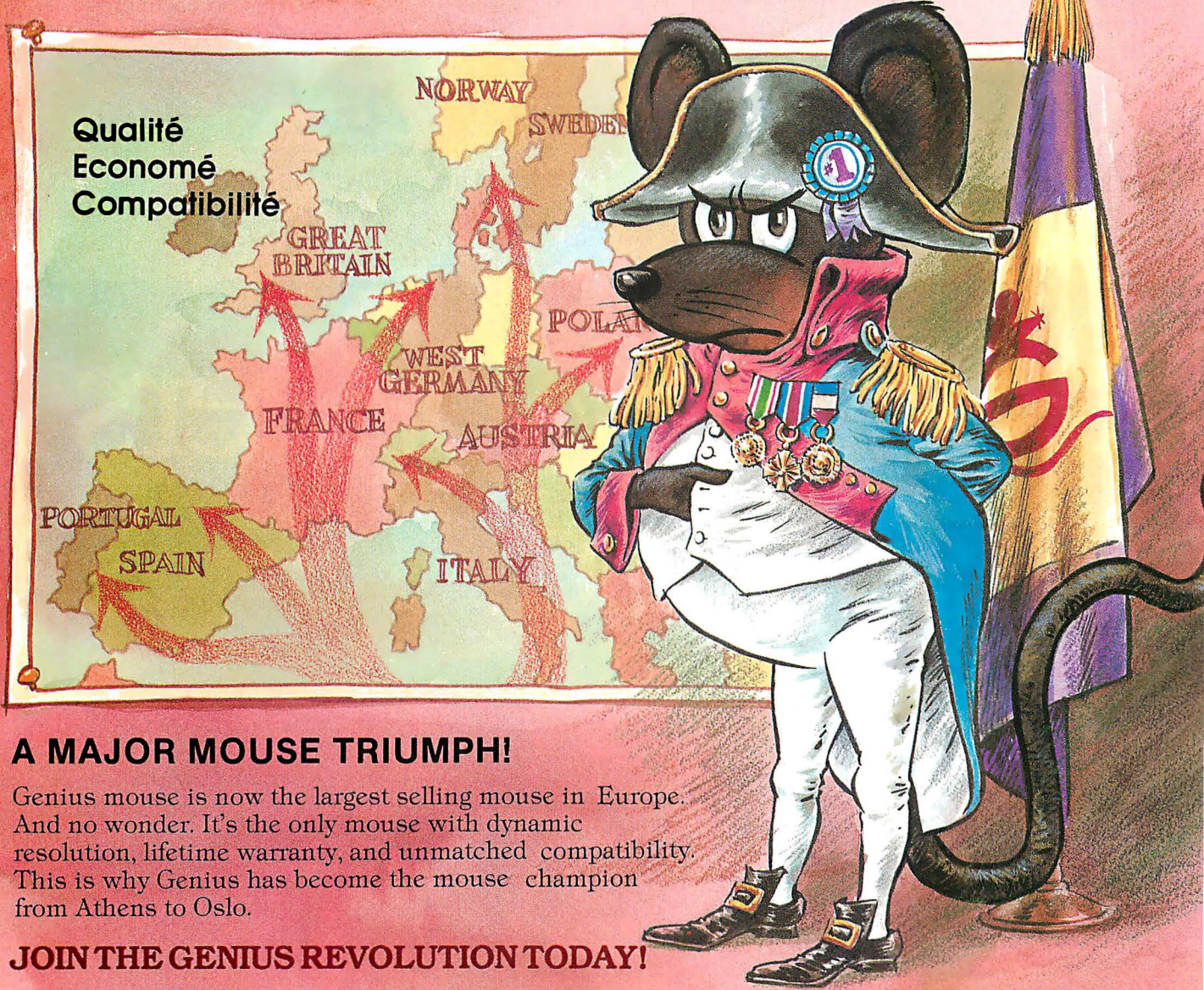

Qualité
Economé
Compatibilité

A MAJOR MOUSE TRIUMPH!

Genius mouse is now the largest selling mouse in Europe. And no wonder. It's the only mouse with dynamic resolution, lifetime warranty, and unmatched compatibility. This is why Genius has become the mouse champion from Athens to Oslo.

JOIN THE GENIUS REVOLUTION TODAY!



Genius Mouse GM-6000

- High Resolution 350-1050 DPI.
- Dynamic Resolution.
- Switch select 2 or 3 button
- Optomechanical Serial mouse
- Mouse pocket & pad
- Menu Maker & Dr. Halo

List price \$119



Geniscan GS-2000 Plus

- 100, 200, 300, and 400 DPI
- Multi Window Scanning
- Overlap and merge images
- IMG, MSP, CUT, PCX, TIF, and OCR format
- Extended printer support

List price \$299



Genius Tablet GT-1212

- Resolution to 1000 LPI
- Accuracy to .01 inch
- 12" x 12" digitizing area
- AutoCAD template included
- Tablet or mouse mode
- Menu Marker & Dr. Halo

List Price \$399



KYE INTERNATIONAL CORP.

769 PINEFALLS AVE.
WALNUT, CA 91789
TEL: (714) 594-9234
FAX: (714) 594-5554

KUN YING ENTERPRISE CO., LTD.

11F, NO. 116, SEC. 2, NANKING E. ROAD
TAIPEI, TAIWAN, R.O.C.
TEL: (02) 565-2817
FAX: (02) 511-0873

Circle 148 on Reader Service Card
(DEALERS: 149)

• All brand of product names are trademarks or registered trademarks of their respective holders.



Full-Spectrum Scanners

The Sharp JX-450 and the Howtek Scanmaster bring affordable color scanning to the Mac II

Tom Thompson

Photo 1 (below, left): The Sharp JX-450 produces excellent results but requires a substantial amount of memory.

Photo 2 (below, right): Howtek's Scanmaster offers superior scanning software on a hardware platform identical to that of the Sharp unit.

The Mac II's rich set of color graphics primitives and its versatility at manipulating color bit maps make it a powerful image processor. But to take advantage of these capabilities, you've got to get the color images into the computer in the first place.

While you can do this easily enough in shades of gray with existing scanners (see "Bringing the Outside World into a Macintosh" by Laurence H. Loeb, October 1988 BYTE), the ability to achieve this result in color has been a long time coming. That's not to say that it couldn't be done, but the equipment to do it cost dearly—usually tens of thousands of dollars.

Now two vendors, Sharp Electronics and Howtek, have introduced scanning packages that can electronically reduce a color photograph to binary data and convert it into color formats that many Mac II applications can use (for a detailed de-

scription of how these scanners capture an image, see the text box "Color Scanning Explained" on page 191). Both packages accomplish this operation in just minutes. But their most important feature is their nonstratospheric prices: Sharp's top-of-the-line JX-450 color scanner package costs \$7565, and the Howtek Scanmaster package is priced at \$8195. Both scanners also work with the IBM PC and PS/2s.

Mirror Image

It's no coincidence that the Sharp and Howtek scanners look alike: With the exception of the company nameplate, both scanners are identical. Howtek buys its scanner from Sharp and resells it with its own interface board and scanning software (see photos 1 and 2).

The scanners closely resemble a flat-bed copier, right down to the hinged cover that holds the original down on the

continued



Sharp JX-450

Type

Flatbed color scanner

Company

Sharp Electronics Corp.
Sharp Plaza
Mahwah, NJ 07430
(201) 529-9500

Features

Scans images up to 11 $\frac{5}{8}$ by 17 inches at 75, 100, 150, 200, and 300 dpi in 24-bit color; optional mirror unit lets you scan transparencies up to 8 $\frac{3}{4}$ by 11 $\frac{5}{8}$ inches; can be programmed to scan in resolutions as low as 30 dpi in single steps up to 300 dpi; can scan images at several speeds and degrees of sharpness; PixelScan software drives scanner in various modes and saves images in several formats

Size

21 $\frac{3}{4}$ × 20 $\frac{7}{8}$ × 7 $\frac{5}{16}$ inches; 55 pounds

Hardware Needed

Macintosh II or IIx with at least 2 megabytes of RAM and a 40-megabyte hard disk drive; NB-GPIB package, which contains NB-GPIB NuBus board, driver software, and GPIB cable

Software Needed

Finder 6.1/System 6.0.2 or higher

Options

Mirror unit to scan transparencies: \$500
NB-GPIB package: \$570

Documentation

Programming manual

Price

\$6995

Inquiry 851.

image table. Markings on the sides of the image table let you accurately position eight different sizes of documents: U.S. office, legal, invoice, and tabloid, plus the European A3, A4, B4, and B5 standard sheets. If you want to scan slides or transparencies, Sharp's optional mirror unit or Howtek's transparency option must be attached to the scanner so that it redirects the light from the scanning lamps through the film.

Both scanners use an IEEE-488 general-purpose interface bus to communicate with the host computer. This means that, in addition to the scanning unit, GPIB interface hardware is required. Both products use the National Instruments NB-GPIB NuBus board, the NI-488 driver,

Howtek Scanmaster

Type

Flatbed color scanner

Company

Howtek, Inc.
21 Park Ave.
Hudson, NH 03051
(603) 882-5200

Features

Scanner unit characteristics are identical to the Sharp Scanner; also includes NB-GPIB NuBus board, software driver, and cable; MacScan-It application drives scanner in various modes and saves captured image in several formats

Size

21 $\frac{3}{4}$ × 20 $\frac{7}{8}$ × 7 $\frac{5}{16}$ inches; 55 pounds

Hardware Needed

Macintosh II or IIx with at least 2 megabytes of RAM and a hard disk drive

Software Needed

Finder 6.1/System 6.0.2 or higher

Options

Transparency scanning option: \$659

Documentation

Operator's guide; MacScan-It user's guide; GPIB installation guide

Price

\$8195

Inquiry 852.

and a GPIB cable to complete the connection. Finally, you'll need application software that talks to the scanner, retrieves the image data, and saves this information in a disk file. I call this combination of hardware and software a scanning package, since all the components in the package are required to obtain a scanned image.

You don't always get a complete scanning package when you buy a scanner. Howtek provides its Scanmaster scanner, power cable, and scanning software, along with the NB-GPIB interface board, driver software, and interface cable, as a complete package. Sharp, however, sells its JX-450 scanner, power cable, and scanning software as a unit for \$6995. To

connect the JX-450 to the Mac II, you need to buy the GPIB interface board, driver software, and interface cable for an additional \$570.

Workspace Required

You'll need plenty of desk space or a large open spot on your office floor to accommodate these scanners. Measuring 21 $\frac{3}{4}$ by 20 $\frac{7}{8}$ by 7 $\frac{5}{16}$ inches, they each occupy more space than an IBM AT. The large size is necessary to accommodate up to a 12- by 17-inch document. You'll also need an additional foot of clearance on each side of the scanner, as the scanning bed moves from side to side during operation. Fortunately, the 6 $\frac{1}{2}$ -foot-long GPIB interface cable lets you place the scanner some distance away from the computer.

To take full advantage of these two scanners, you're going to need a hefty amount of resources. The Mac II you intend to use should have at least 2 megabytes of RAM and a high-capacity hard disk drive (I recommend at least 8 megabytes of RAM and a 100-megabyte hard disk drive). Images with 8-bit-deep color pixels need lots of RAM and disk space, so the more RAM and the larger your hard disk drive, the better off you'll be.

As with most Mac II NuBus peripheral boards, installation is a breeze. First, you pop the Mac II's hood, drop the NB-GPIB interface board into an empty slot, close the computer, and reboot. Then you copy the NB Handler INIT file to the Mac's System Folder. This INIT contains the NI-488 driver, which installs into the Mac II's system heap when you reboot the machine. Applications that work with the scanner use this driver to communicate through the GPIB interface. If you have more than one GPIB board in your system, the `ib-conf` application written by National Instruments and supplied with both scanning packages lets you configure the NB Handler INIT for a particular board in the system.

All that's left is to copy the scanning application to the Mac II's hard disk, and you're set. Sharp provides a PixelScan application that can operate the scanner at various resolutions and scanning speeds and save the image in several data formats. Howtek's MacScan-It application has similar features, but it has better color controls and can save data in a wider range of data formats.

Once system setup is complete, you place a photo or document onto the scanner table and switch the unit on. After the scanner warms up, you launch the scanning application. First you select the

scanning mode, resolution, and color palette, and then you issue a scan command. The scanning bed moves from right to left, and in about 1½ minutes (at the fast scan setting), a color image fills the window of the scanning application. If you've set your color controls correctly, the results can be spectacular.

Not Created Equal

Although both scanning packages are virtually identical in terms of the scanning unit and GPIB interface, they differ significantly when it comes to the scanning software they supply. Sharp's PixelScan version 1.1a, written by SuperMac Software, provides only minimal capabilities. You can choose from a wide variety of scanning settings: resolution (36, 75, 100, 150, 200, or 300 dots per inch, or adjustable), image size (including U.S. and European formats), brightness correction (normal or lighter), scanning speed (slow, fast, or custom), and image sharpness (normal, sharp, exaggerated, or softened).

You can scan a picture using the Mac II system colors, custom color palettes, or gray scales. You can also specify whether you want dithering performed during the scan. For certain custom palettes, the scanner captures the image in two passes. The first examines the image's colors and then selects (from the Mac II's palette of 16.7 million colors) the 256 colors that best represent the image; the second pass performs the image scan. You can save the image in PICT2, PixelPaint, and MacPaint formats. PixelScan also has a SIZE -1 resource, making it MultiFinder-compatible.

The size and resolution of each scan is limited by available RAM. The only way you can control the size of the scanned area on the scanning bed is through canned document-size settings. The PICT2 file format is the graphics *lingua franca* for exporting color images to other Mac applications, but the MacPaint format, which handles only black-and-white images, makes no sense for a color scanner.

Although PixelScan operates under MultiFinder, it allows little or no background processing during a scan. I attempted an XMODEM download from BIX at 1200 bps using Red Ryder 10.3 in the background. The download timed out while PixelScan captured a large document.

Howtek's MacScan-It 1.0 is the more polished application, although the program and documentation was shipping in preliminary form (Howtek says it will provide free upgrades of the final version

Color Scanning Explained

Sharp's color scanner is operationally similar to a gray-scale scanner. It measures the light intensity at certain points along the original image and converts this intensity level into digital values. However, a typical gray-scale scanner detects only 16 different light intensities (or shades), while the Sharp JX-450 scanner detects 256 different light intensities. And while a gray-scale scanner captures an image once, the Sharp scanner must do it three times, measuring the red, green, and blue intensities for each part of the image (for gray-scale images, the scanner uses only the green lamp).

The process is further complicated by the fact that all three RGB measurements must be aligned to the exact same points on the image. Otherwise, the combined color measurement would correspond to several different points on the image, resulting in color fringing or a garbled image. The process is similar to the careful alignment required to print a color picture like those in this magazine: If even one of the colored inks is printed out of register, the image is ruined.

Sharp's solution to this problem is ingenious. The original photo lies on the image table. The image table remains stationary while the JX-450 fires three colored fluorescent lamps (red, blue, and green) in sequence. Red and blue filters mounted over the red and blue lamps help to improve their spectral characteristics. This light then shines through a slit on the image table and onto a band of the image.

The light reflected from the image band is directed by two mirrors onto a charge-coupled-device (CCD) sensor strip. The strip contains 3648 photosensitive elements that measure the intensity of the light that falls on them. The sensor strip has sufficient elements

to measure a band across the widest part of a European A3 document (297 millimeters, or about 11¾ inches) at 300 dpi. The light intensity for the particular color component (determined by the color of the lamp illuminating the image) is digitized into 256 levels (8 bits), although Sharp guarantees only 6-bit accuracy for each component.

The scanner sends the intensity information for the image band at this particular color to the host computer. Measurements of the next color component for the same band start when the next lamp fires.

Once all three lamps have fired and all the RGB color information for this image band has been captured, the scanning table moves slightly. This exposes a new part of the image, and the measuring process repeats. In this manner, the entire image is assembled, one band at a time. The only possibility for misalignment is if the scanning table moves inaccurately, but this only causes problems with the alignment of bands of the image, not with their colors.

To scan transparencies, the scanner uses an optional mirror box that directs light from the lamps through the film. Two mirrors in the device guide the light from the image table slit across the scanning table, through the film, and onto a third mirror inside the scanner. This third mirror then reflects the light onto the CCD sensor strip.

While this process might seem extremely complicated compared to the operation of a gray-scale scanner, the color scanner must capture three times as much information—all of it required to produce a realistic image. The Sharp scanner tackles this problem with a simple but effective design. The effort is worth it: The color images look worlds better than anything a gray-scale scanner could generate.

to users who buy the preliminary version). The program has the same image-size and image-sharpness menu selections as PixelScan. You can scan at resolutions of 75, 100, 150, 200, or 300 dpi, or at variable resolutions.

MacScan-It lets you scan an image as a positive or a negative, and with continuous colors or gray scales. If you're scanning transparencies or slides, MacScan-It has a large selection of color lookup

tables for many types of films (e.g., Kodak, Konica, 3M, and Fuji). Unlike PixelScan, it also has a useful preview mode that lets you look at the image on the scanning table before starting the final scan. You can then resize a preview window to surround the picture entirely or crop the part that you want.

MacScan-It uses the preview window's dimensions to determine the area

continued

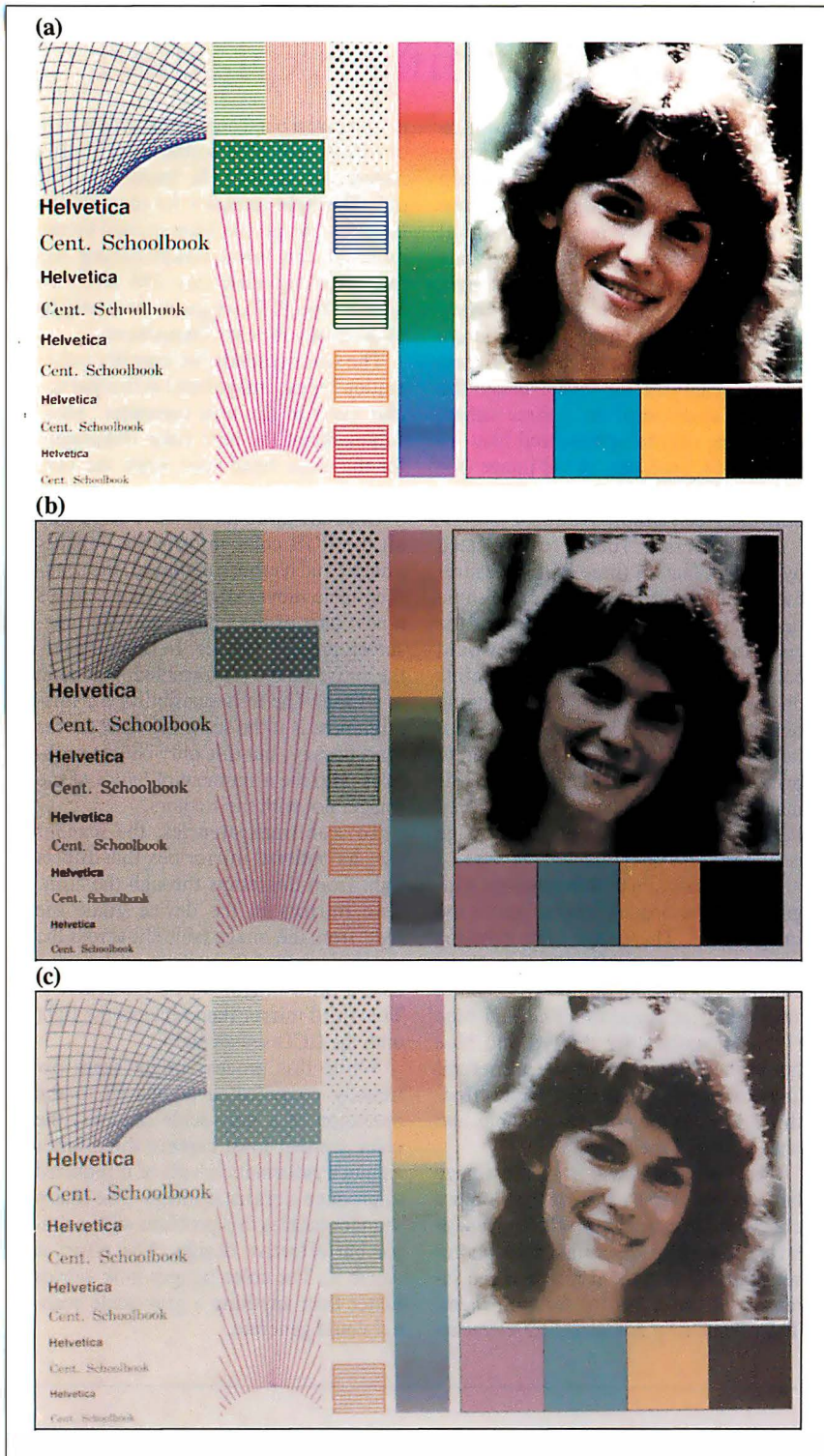

Figure 1: (a) The BYTE color test pattern for scanner quality. (b) The test pattern scanned at 300 dpi on the Sharp JX-450. (c) The pattern scanned at 300 dpi on the Howtek Scanmaster. All images shown are actual size. I used LaserPaint Color II with the Sharp JX-450, and MacScan-It with the Howtek Scanmaster. To avoid degrading the image quality, I saved the images as PICT2 files and sent them to a computer graphics firm to make direct color separations. The firm experienced some difficulties with the LaserPaint image, so that image was exported as a TIFF file to Avalon Development's PhotoMac application and saved as a PICT2 file.

to be scanned—a nice touch that saves RAM and disk space. It also saves the data in a larger variety of formats: SIM (a proprietary format that saves all 24 bits of color information), PICT2, 24-bit TIFF (for use with PageMaker and Ready-Set-Go!), and RIFF (for use with ImageStudio).

MacScan-It is stingy with memory. As it obtains 24-bit image data from the scanner, it spools the data to a temporary file on the hard disk. It uses this 24-bit data, as well as any color corrections you've selected, to paint an 8-bit-deep image on the screen. This makes scanning much slower (it took about 3 minutes to scan and view a legal-size document with MacScan-It versus 1 1/2 minutes for PixelScan), but if you use a 2-megabyte machine, you can make large 300-dpi scans without running out of memory.

You also can make certain color corrections (i.e., auto-white, auto-gray, auto-contrast, and custom gamma corrections) once you've scanned in an image. MacScan-It reads the 24-bit color image data from the temporary file as it applies the corrections. This makes additional scans unnecessary, and all color corrections use the same high-quality image data. MacScan-It is also Multi-Finder-compatible, and it does a better job of allowing background processing. The XMODEM download completed successfully while MacScan-It worked on a large document.

Neither PixelScan nor MacScan-It can read files. This is understandable, since the primary goal of these applications is to get images into the computer. But MacScan-It's utility would certainly be enhanced if it could read its own SIM files. This capability would enable you to manipulate the image data later without rescanning the image.

I used the BYTE test pattern to judge the quality of the images I scanned (see figure 1). I tested both packages with a Mac II equipped with a SuperMac Technologies Spectrum/8 video board and 19-inch color monitor; I configured the system alternately with 2 and 5 megabytes of RAM. PixelScan distorted or lost portions of the test images at the high dpi settings. I had to resort to LaserPaint Color II to scan in the test pattern on the Sharp scanner.

When I tried to crop the 300-dpi image, LaserPaint didn't have enough RAM to perform the operation; I had to install an additional 4 megabytes of RAM (for a total of 8 megabytes). As figure 1 shows, the test pattern isn't very

continued

BURN ALL YOUR COMPUTER BOOKS!



YES! YOU CAN NOW BURN ALL YOUR COMPUTER BOOKS AND STILL BE AN ACE PROGRAMMER!

GEYSER "ON-SCREEN REFERENCE BOOKS" ARE EITHER MEMORY RESIDENT OR STAND ALONE PROGRAMS. THEY POP UP INSTANTLY AND PUT ALL THE INFORMATION YOU NEED RIGHT AT YOUR FINGERTIPS!

WITH GEYSER "ON SCREEN REFERENCE BOOKS" YOU CAN NOW:

- ASK ANY QUESTION IN PLAIN ENGLISH USING ITS UNIQUE "PERSONAL WORD SEARCH" QUERY SYSTEM.
- GET THE EXACT SYNTAX AND USAGE OF ANY COMMAND BY USING THE "COMMAND REMINDER" WINDOW.
- SCAN THE ON-SCREEN BOOK BY TOPIC USING THE OVERVIEW FEATURE.

THE GEYSER COLLECTION INCLUDES THE FOLLOWING TITLES:

NOW AVAILABLE			
DOS	dBASE III PLUS	WORDPERFECT	LOTUS 1.2.3
TURBO C	CLIPPER	WORDSTAR	
TURBO PASCAL		XYWRITE III PLUS	
MS FORTRAN			

AVAILABLE END OF MARCH 89			
PROLOG	REFLEX	SPF/PC	SYMPHONY
TURBO BASIC	DATAEASE	PFS/PROF. WRITE	QUATTRO
TURBO ASSEMBLER	dBASE IV	MS WORD	SUPERCALC
		DISPLAYWRITE	

AVAILABLE END OF APRIL 89			
XENIX	FOXBASE	WORDSTAR 2000 PLUS	MULTIPLAN
ADA	R:BASE	MULTIMATE	FRAMEWORK

NO MORE ENDLESS PAGES FLIPPING.
NO MORE WASTED TIME SEARCHING.
NO MORE TRAIN-OF-THOUGHT DERAILMENT.

\$95.⁰⁰ WILL BUY YOU
FREEDOM FROM BULKY MANUALS.
ORDERS: 1-800-361-7273

EACH GEYSER ON-SCREEN REFERENCE BOOK IS AVAILABLE ON DISKETTE FOR ONLY \$95.00.

GEYSER ALSO HAS A CORPORATE CUSTOMIZATION SERVICE DIVISION THAT MAKES OUR LEADING EDGE TECHNOLOGY AVAILABLE FOR CUSTOMER SALES SUPPORT OR TRAINING. THIS DIVISION OF GEYSER CAN APPLY OUR UNEQUALLED ON-SCREEN HELP TO ANY KIND OF BOOKS, MANUALS OR CATALOGUES. FOR FURTHER INFORMATION CALL: (514) 842-5719. FAX: 514-285-1138

See us at COMDEX Canadian Government Booth



Geysler Informatics Inc.

SYSTEM REQUIREMENTS: 640K RAM, A HARD DISK, IBM/XT, AT, 386OR 100% COMPATIBLES AND PC-DOS OR MS-DOS VERSION 2.0 OR HIGHER.
TO ORDER: CALL TOLL FREE: 1-800-361-7273 CREDIT CARDS: AMERICAN EXPRESS - VISA - MASTERCARD

GENERAL NOTICE: THE PRODUCT NAMES USED HEREIN HAVE BEEN USED FOR IDENTIFICATION PURPOSES ONLY AND MAY BE TRADEMARKS OF THEIR RESPECTIVE COMPANIES.

26 Broadway
Suite 400
New York
NY 10004
USA

507 Place d'Armes
Suite 1701
Montreal (QUE)
H2Y 2WB
CANADA

large, so, obviously, software that works with copies of an image in memory isn't going to handle large 300-dpi scans. By contrast, with MacScan-It, I was able to crop the image in preview mode, and it performed the scan without a hitch.

Since the scanning hardware is virtually the same, the quality of the test patterns was nearly identical. The only differences, as evident in the continuous-tone portrait, seem to be in the software itself. When both scanners captured the

same image, the quality of the image was the same, but the PixelScan image tended to be darker in tone than the MacScan-It image. MacScan-It lets you manipulate the image colors if good color fidelity is required, but with PixelScan, you'll need a graphics application to touch up the image.

Tough Choice

No matter which package you buy, you're going to end up with a Sharp scan-

ner, so your choice is between the two scanning software packages. Is the Howtek package worth the extra \$630? Look at it this way: If you buy the Sharp package, plan on using the money you saved to buy decent scanning software, because PixelScan is inadequate. Even though the Howtek MacScan-It software is preliminary, it does a far better job.

Possible candidates to replace PixelScan are LaserWare's LaserPaint Color II (which drives both the Sharp and Howtek scanners) for \$595, SuperMac Software's PixelPaint 2.0, also \$595, or Imagenesis's ChromaScan software for \$195. Registered owners of Letraset's ImageStudio can obtain a special scanning module from Sharp for free.

If you plan on scanning large images at 300 dpi, you might want to factor in the cost of additional RAM. You'll need at least 5 megabytes (preferably 8) to work comfortably with either scanning package (a 4-megabyte RAM-expansion kit from Apple costs \$2300).

But in most cases, MacScan-It will let you get by with less memory. First, MacScan-It lets you crop the image area before you perform the scan. You capture only the part of the image you need, not everything that fits within a fixed sheet size. This saves on RAM and disk space and on the cost of a color paint package to crop the image. Second, since MacScan-It spools image data to disk instead of holding it in memory, you can make large, high-resolution scans in 2 megabytes of RAM.

The Sharp scanning unit is an impressive piece of hardware that lets you digitize color images and save them on your computer in a matter of minutes. The results are crisp and snappy. More important, these relatively low-cost color scanners open up new possibilities in the areas of art, scientific, and multimedia applications. For example, a doctor might scan x-rays in gray scale and then use false colors to help pinpoint a tumor or blood clot. Research geologists would digitize satellite photos and enhance their contrast to bring out specific details hidden in the image.

Now that the technology to import color images quickly and easily is available at a reasonable cost, the Mac II is set to fulfill its promise as an image-processing engine. And the scanner's ability to collect 24-bit data makes it ready for Apple's 32-bit Color QuickDraw when it arrives. ■

Tom Thompson is a BYTE senior technical editor at large. He can be reached on BIX as "tom_thompson."

S=100 "THE PC PEOPLE"

MMG

SINCE 1977

Ad Code
BL-E9



PC SYSTEMS

ARC XT'S, Super AT'S, Turbo Workstations.....CALL
Nationwide on-site service available!



AST Premium/286-Model 80.....CALL

AST Premium/386-Model 300.....CALL

Indtech "Industrial strength Tower Systems".....CALL

LAPTOPS



MITSUBISHI MP286L 12mhz, 0wait, 640K, 11" white screen, CGA, HGC Ext Video adptr., 1.44Mb floppy, 20Mb hard drive, 2 ser/1 par. ci/ccl, ext floppy ports, 4 proprietary slots, DOS 3.3, 3.5W Basic.....\$2,449
MP286L with 40Mb Drive.....\$2,888

MONITORS

SAMSUNG EGA 911" 5' swivel, 14".....\$359

SAMSUNG 12" TTL fill'n' swirl amber.....\$79

TATUNG CM-1495 OmniScan 14" Multi-freq, 800x600, VGA, EGA, CGA, w/VGA card.....\$695

TATUNG CM-1496 VGA 14" w/VGA cd.....\$679

MDS "The Genius" Full PG for PC/XT/AT.....\$749

MONITER 19" & 24".....CALL

Packard-Bell 1472W soft w/ht/dual mode.....\$119

Packard-Bell 1443CG 14" color.....\$239

XTRON MF147W soft white 14" FLAT.....\$119

XTRON CM147E EGA 14".....\$359

XTRON CM1481 VGA 14".....\$394

XTRON CM 147M Multisync 14".....\$469

ZENITH FTM - 1490 VGA Flat screen.....\$599

TERMINALS

WYSE WY-50 green or amber.....\$389

WYSE WY-60 w/keyboard.....\$425

PRINTERS, PLOTTERS, & FAX

EPSON FX 286e.....\$375

BROTHERM-1109 Narrow 120 GPS.....\$149

BROTHER M-1709 220 cps Wide.....\$269

BROTHER 2024L 24 Pin Wide/Trace.....\$329

Brother cut-sheet-feeders at super low \$!

HOUSTON INSTRUMENT PLOTTERS, DIGITIZERS.....CALL

SUMMA SKETCH 12X12.....\$365

SUMMAGRAPHICS PRO 12X18.....\$639

SUMMAGRAPHICS MAX 12X12.....\$389

FAX

XEROX 70175F store & forward.....CALL

LASER PRINTERS & SCANNERS

Brother HL-8e 40 fonts 8PPM 2nd gen. Canon Engine Emulates Epson, IBM, Diablo 1Mb RAM Full PG graphics HP Laser Jet Plus compatible.....\$119

EVEREX POSTSCRIPT LASER.....\$2,495

H.P. Laser Jet Series II.....CALL

Font Cartridges From.....\$119

Panasonic 4450 Laser dial tray, 11PPM.....\$1,349

EVEREX 60iint - 60Mb int. tapew/softw.....\$839

EVEREX 125Mb internal tape.....\$1,099

CDC 90Mb HH SCSI.....\$825

CDC 155 FH SCSI.....\$1,339

CDC 300 FH SCSI.....\$1,949

MAXTOR XT-1140 140Mb.....\$1,695

MICROPOLIS

MICROPOLIS 1335 85Mb 28mSec.....\$549

MICROPOLIS 1375 170Mb SCSI.....\$1,395

MiniScribe

MINISCRIBE 3085H 22mSec 72Mb.....\$779

DriveCards-anyone can install in 5 minutes!

MINISCRIBE Drive Card 30Mb.....\$355

MINISCRIBE 8225 XT 20Mb W/CTRL.....\$239

MINISCRIBE 8425F 20Mb 40mS 3.5".....\$249

FLOPPY DRIVES

Fujitsu 360K.....\$75 1.2Mb.....\$95

Fujitsu 1.44.....\$109 1.2.....\$126

Mitsubishi 360K.....\$69 1.2.....\$119

720K.....\$99 1.44.....\$119

T or at 360K.....CALL 1.2.....\$98

Teac 1.44.....\$98

MODEMS

INTEL Connection CoProcessor.....\$698

ANCHOR 2400 PS/2 Modem.....\$175

EVEREX EverCom 2400 int/MNP3.....\$159

2400E MNP3.....\$199

MULTITECH Multi-Modems.....CALL

US ROBOTICS Courier HST to 19 200bps.....\$629

Spartster 2400 Ext.....\$178 / 2400 PCS.....\$158

Spartster 1200 E.....\$98 / 1200 PC.....\$68

BOARDS

ADV-Prem-PIGGYBACK 512K S.P.....\$368

AST Advantage-PS/2-512K 2Mb.....\$305

AST Hot Shot 286-10XT Accal. Bd.....\$369

AST I/O MINI II XT or AT.....\$279

AST RAMPAGE 286 - 512K.....\$395

AST RAMPAGE 2 for XT 256K - Ml. 30.4 279

AST, VGA + 256K 16 bit \$339/VGA 8 bit \$249

EVEREX Ultra graphics & 19" Monitor.....CALL

EVEREX Deluxe EGA 640x480 + prt.....\$179

EVEREX VGA.....\$269

INTELABoveBD/286-Piggy-back 512K \$379

INTEL 80287-8.....\$240/80287-10.....\$269

INTEL 80387-20 Math Coprocessor.....\$485

INTEL Connection Coprocessor.....\$698

NETWORKING

VAR's let us configure a plug'n play system ready to load your application software!

4 user NOVELL Network

ARC-12MHz 80286-12/0, S & 2P, Mono monitor, 1.2Mb floppy 2Mb RAM, 72Mb Drive, 60Mb Tape & Dos 3.3

* American Power Conversion 520W UPS

* Novell ELS Ne Ware 286 Level 1

Novell Systems Mgr & User Basics Tutorials

2400 Baud Modem W/PC Anywhere for Support

* 4 ArcNet cards, cable, 4-part passive hub

* 3 ARC ProTurbo88, 10 MHz, 640K, S.P,

XTRON 14" TN'S flat screen Monitor

* Telephone assistance during installation

Your cost.....\$8,888

PC SOFTWARE & MICE

DATA BASE MANAGEMENT

Ashon-Tated Base III Plus.....\$379

PFS: Professional File.....\$159

WordTech DBXL (dBase 3) "Diamond".....\$115

COMMUNICATIONS

Carbon Copy Plus (Meridian).....\$109

PC Anywhere.....\$85

WORD PROCESSORS

VolksWriter 3+ Speller.....\$199

Microsoft Word.....\$225

MultiMate Advantage II.....\$258

PFS: Professional Write.....\$105

Word Perfect.....\$229

INTEGRATED / SPREADSHEETS

Enable 2.0 (software group).....\$369

FrameWork III.....\$398

Microsoft Excel.....CALL

PFS: First Choice.....\$85

PFS: Professional Plan.....\$58

Symphony (Lotus).....\$438

DESKTOP PUBLISHING

PFS: First Publisher.....\$69

PFS: Art Gallery.....\$69

Xerox Ventura 2.0.....\$469

Aldus PageMaker/PC 3.0.....\$525

GRAPHICS & MICE

Harvard Graphics (for Lotus 1-2-3).....\$248

MSC OmniMouse/Point.....\$55

MSC PC Mouse/Bus/Sr.....\$88

IMSI Genius Mouse Serial.....\$59

Microsoft Mouse From.....\$98

SummaSke II 12x12.....\$365

PROJECT MANAGEMENT

Harvard Teal Project Manager.....\$349

Synapse Time Line.....\$269

Microsoft Project.....\$315

Comp.Assoc. SuperProject.....\$269

*Compatibility with PC/XT/AT Clones not guaranteed.

*Order Carefully. Opened software not returnable!

800-528-3138 Orders Only 602-991-7870 Customer Service

S-100 Div./696 Corp. • 14151 N. 76th St. • Scottsdale, AZ 85260

◆ TELEX 9103806778 SNSCORP ◆ FAX 602-483-0920

Advertised prices are cash, prepaid, Visa or MasterCard Only! Customers using AMEX, DOD's or qualifying for terms, calculate additional charges by dividing above prices by .95. Credit card charged after shipment. Special order items, special programs and they are not cancellable/returnable. Shipping list \$15.00, minimum \$8.00. *101cs. \$1200 *FREE FEDERAL 18 Lbs. Priority. Safelast. Arizona residents only. Product returns may be subject to a restocking fee or full credit toward a future purchase. All prices and specifications subject to change without notice.

UNINTERRUPTIBLE

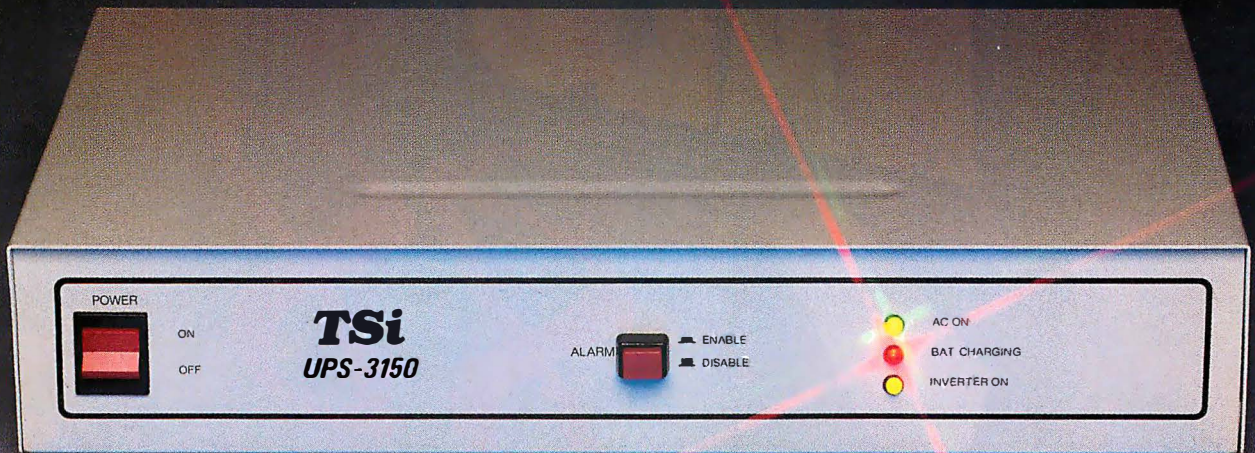

Power supply is crucial. The slightest flicker in power can mean lost data, decreased production and hours of reorganization. Lightning strikes result in billions of dollars in equipment damage each year. AC line noise, electromagnetic or radio frequency noise cause erratic system performance and computer screen glitches. In short, there are 3 things you can count on. Power outages, noise interference and the TSi Uninterruptible Power System to solve these problems.

There's never been a better way to insure against the hazards of power surges, voltage sags, blackouts and bad weather. TSi's performance proven products give plenty of warning before a system goes down. If the power goes out, an audible alarm sounds which notifies you that the TSi Uninterruptible Power System is on the job.

TSi Uninterruptible Power Systems are as innovative as they are reliable. Sophisticated modular architecture provides efficient options. Analyze the exact power protection you need to cover equipment and applications. TSi's systems are configurable to meet today's needs and reconfigurable to change and expand for the future. Cost effective insurance for 286 and 386 based computers. Slimline design, optional cabinet, rack and wall mountings on selected models make excellent use of space. Durable, rigorously tested, UL listed products from TSi that save time and money. So be ready when power problems occur.

Suggested Retail \$349.00

TSi

TAESUNG INDUSTRIES, INC.

2001 WESTSIDE PARKWAY SUITE 240 ALPHARETTA, GEORGIA 30201 • TEL: 800-874-3160 • FAX (404) 664-5252

Circle 287 on Reader Service Card (DEALERS: 288)

NEW UPDATE — Extended VGA Support



The Graphics Toolkit for Contemporary Software Developers

Already the fastest and most powerful graphics toolkit on the market, the new HALO® delivers subroutines and device support for exciting, contemporary applications in publishing, office automation, vision, and image processing.

HALO '88 is a device independent library of 190 graphics subroutines. It is compatible with 18 programming languages, and over 140 hardware devices such as image scanners; graphics, vision, and imaging boards; printers and plotters; and mice. HALO '88 is designed for the complete IBM compatible microcomputer line including the PS/2 and VGA.

Today's Tools for Tomorrow's Applications

HALO '88 has new subroutines which control scanners and scanned images — even images which are larger than screen resolution and available memory. Extended character set support enables software developers to address IBM's

full 255 characters in graphics and to design foreign language fonts. Among contemporary HALO '88 applications are CAD, Computer-Based Training, Presentation Graphics, Graphic Arts, Mapping, Machine Vision, Silicon Wafer Manufacturing, Sound System Design, Vehicle Scheduling and Routing, and Real Estate.

Join the HALO Family

HALO has an installed base of 60,000+ end-users, hundreds of site-licensed corporations, government agencies, universities, and national laboratories and most importantly, over 220 Independent Software Developers (ISVs) who market applications written with HALO.

HALO '88 provides the software designer with the richest environment of graphics functions; the programmer with reliable and

well-documented tools, and DP managers with continuity of user interface and database format.

Reach for the Future

If you need high performance graphics development software that provides a migration path to OS/2 and other future technology, follow the industry leaders — call (800) 992-HALO (4256).

HALO '88 is just \$325 and includes all device drivers, 20 fonts, your choice of one compiler binding, completely new documentation, an interactive tutorial and free 800# technical support.

Ask about the new HALO Programmers' Workbook which provides C program examples for HALO '88 applications developers.

media cybernetics
8484 Georgia Ave.
Silver Spring, MD 20910
(301) 495-3305, (800) 992-HALO

HALO is a registered trademark of Media Cybernetics, Inc. IBM PS/2, VGA and OS/2 are registered trademarks of International Business Machines Corp.





Extend

A general-purpose simulation toolkit for the Mac

Ray Valdés

By simulating real-world behavior in software, computers help us to understand the world outside of the machine. This simulation entails modeling the flow of matter, energy, or information through a real-world system. Extend 1.05 from Imagine That! is a simulation toolkit for the Macintosh. Like the traditional packages Simscript and General Purpose Simulation System, Extend reduces the behavior of a system that it models to a graph or a chart. Unlike its mainframe predecessors, Extend provides a slick object-oriented environment within which you construct simulations—in effect, a tinker-toy set that you use to graphically define and interconnect processes and flows. I used it to explore the dynamics of a commuter highway; it's equally well suited to problems in biology, business, economics, medicine, or physics.

I ran Extend on a Mac SE with 4 megabytes of RAM and a 40-megabyte hard disk drive. I tried the package with a Radius 68020 accelerator card and with the standard 68000 CPU. The accelerator isn't required, but I recommend one for serious work. I began with version 1.05 and later received a beta copy of version 1.1, which will ship by the time you read this.

The package comprises two 800K-byte floppy disks and a 200-page manual. Earlier versions of Extend (like other Mac applications) shipped with a copy of Apple's System and Finder. The

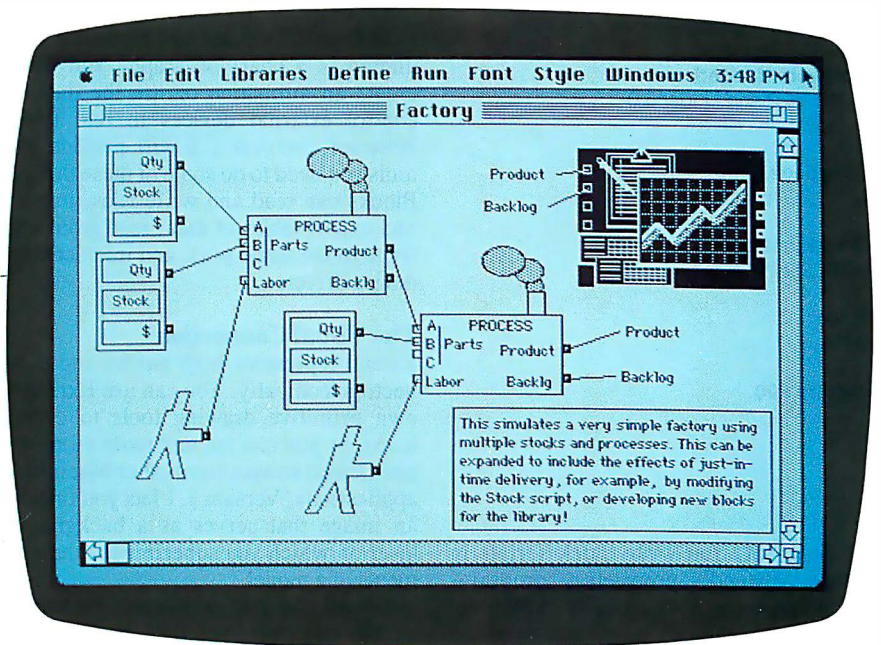

current version assumes you already have Apple's software and fills the disks with additional example files. That's useful, because Extend is complex. The cookbook examples do a good job of showing you how to construct particular kinds of simulations in Extend.

Extend 1.05 occupies 376K bytes of RAM; you need 442K bytes of RAM for version 1.1. There are two types of associated files: stored models, or worksheets, and libraries of model elements, or blocks. The sample models provided with the package range in size from 20K bytes to 50K bytes. A typical library might contain five to 10 blocks and occupy 100K bytes. So, although it's better to have a hard disk drive, you can fit the program, one or two libraries, and a few worksheets on a dual floppy disk drive-based Mac system.

Creating a Simulation

In Extend, as in other simulation programs, a system is a network of entities

that can receive inputs, mathematically transform them, and produce outputs. An entity can be a pure producer, a transformer that both consumes and produces, or a pure consumer. My traffic model comprises four blocks. One, representing a suburb, produces cars. Another, representing a city, consumes those cars. A third represents the highway connecting the two. The fourth plots the flow of traffic through the system.

You can attach as many as 128 I/O ports, or connectors, to a block. In my model, the suburb has a single output connector, the city has a single input connector, and the highway has one of each. What flows through these ports in a simulation model is data in the form of integers, floating-point numbers, or, in the case of version 1.1, arrays. The numbers can represent anything; in the traffic model, they represent cars.

In Extend, the behavior of each block is defined in a stored program called a

continued

Extend 1.05

Type

Simulation modeling toolkit

Company

Imagine That!
7109 Via Carmela
San Jose, CA 95139
(408) 365-0305

Format

Two 800K-byte floppy disks

Hardware Needed

Mac Plus, SE, or II with 1 megabyte of RAM and two floppy disk drives (a hard disk drive is recommended)

Software Needed

System 4.2 and Finder 6.0 or higher

Language

C

Documentation

200-page manual

Price

\$495

Inquiry 890.

block script. You write block scripts in ModL, Extend's proprietary programming language. Syntactically, ModL resembles C, though its object-oriented style (e.g., the way you write handlers for events) reminds me of HyperTalk and Smalltalk. Because Extend contains a script editor, you can develop, test, and refine ModL code within the program.

Once you've configured a model, you run it for a specified length of time. At intervals, Extend sends a simulate message to each block in the system. Blocks can respond to that message by retrieving data from input connectors, processing the input data or simply generating new data, and placing data on output connectors. If you've asked for a graphical or tabular display of the results, as is usually the case, Extend will present one and update it with each tick of the simulation's clock.

For example, I set up my traffic simulation to run for one 24-hour day at 1-hour intervals. Every hour, the suburb produces a batch of cars. The script associated with the suburb governs the number of cars produced; it arranges for peak flows between 6 a.m. and 9 a.m., around noon, and in the early evening. At the

same time, the script for the highway reads and tries to process that batch of cars. The highway can handle a certain number of cars per hour. Excess traffic accumulates on the suburb's output connector—metaphorically, a backlog waiting to be admitted to the highway during the next cycle. For the city's script, I duplicated the logic I used for the highway. The city accepts cars from the highway at a certain rate; excess traffic accumulates as backlog. The script associated with the plotter block reads data that describes the flow of traffic in the city and, using Extend's built-in plotting function, graphically displays those numbers.

In Extend 1.05, the end result of a simulation is a chart or graph. You can't create an animation or use the data to control external devices in real time. However, version 1.1 will provide the tools you need to do some of these things. Blocks can read and write files, import and export tables of data, read from and write to the serial port, and interact with device drivers.

The Visual Connection

Extend represents both blocks and connectors iconically. You can use Extend's own primitive drawing tools to create icons, or you can cut and paste more sophisticated images from other Macintosh applications. Version 1.1 lets you import an image that serves as a background layer on which you superimpose the elements of a model.

Blocks can poll connectors for input, or they can query you for input directly. The latter method provides a powerful mechanism for parameterizing models. With Extend's dialog-box editor, you can create fielded forms. Values entered into those fields are available directly to ModL. Moreover, Extend automatically adds a handler for each field to the associated script. These handlers provide hooks to which you can attach code that validates or transforms input.

In my traffic model, I set the parameters for the capacity of the highway. Running repeated simulations with different values for highway capacity, I found a threshold value—at about half the peak outflow of cars from the suburb—beyond which chaos ensued. Gridlock set in by midmorning and did not clear until well past 9 p.m.

I could have elaborated on the traffic model by creating additional instances of the suburb and highway blocks and connecting them in different configurations to approach a more realistic metropolitan situation. That's easy in Extend, since blocks and connectors behave like ob-

jects in a drawing program. You can select, drag, and duplicate the elements of a model. Because Extend knows that connectors mean something, it maintains the relationship between blocks and connectors when blocks move.

To open a block's dialog box, you double-click on its icon. That's useful, but it points up some limitations inherent in the iconic representation of blocks. First, unless you attach to an icon some visual cue that alerts you to the presence of a dialog box, there's no way to know which blocks in a worksheet might contain useful dialog boxes. Second, because block icons are static images, they can't reflect the status of user-modifiable variables. For example, if I had set up a dialog letting me choose between a two-lane and a four-lane highway, there wouldn't have been any way to get the highway's icon to reflect that.

But that's a minor gripe. Extend implements a flexible and highly interactive environment. You can begin with a simple model (e.g., a few blocks, each with a basic script) and then work incrementally toward the desired level of realism by enhancing scripts, adding user-modifiable parameters in dialog boxes, and changing the configuration of blocks and connectors.

A worksheet has a single main window that shows the configuration of blocks and interconnections. When you press Option and double-click on a block, its editing window or structure window appears. The structure window contains five tiled panes. The largest contains Extend's text editor, which acts a lot like the Lightspeed C editor. The drawing pane, where you construct icons, provides a subset of the MacDraw tools. The tool palette fits uncomfortably into the space provided for it, and I found myself wishing for a tear-off menu instead. The remaining panes contain an editor for creating help texts, a list of the current block's input and output connectors, and a list of the messages that the block can handle. When you invoke the dialog-box editor, it appears in a new pane that overlays the others.

Extend stores the script, dialog box, icon, and help text associated with a model outside the worksheet, in separate library files. The advantage is, of course, that you can reuse parts of the models. However, the disadvantage is that the worksheet file refers to other files that you must transfer when moving to another disk or system. Extend does provide a library manager, with which you can move blocks into and out of libraries.

Table 1: ModL functions by category.

Trigonometric	Sine, cosine, tangent, arccosine, arctangent, cosineH, sineH, tangentH
Numeric	Ceiling, floor, exponent, fast Fourier transform, integrate Euler, integrate trapezoidal, integer absolute value, real absolute value, log base e, log base 10, real modulo, square root, mathematical gamma function*
Matrix*	Conjugate, determinant, Eigen value, identity matrix, complex identity, dot product, complex dot product, LU decomposition, complex LU decomposition, invert, complex invert, matrix product, complex matrix product, scalar product, complex scalar product, vector product, complex vector product, tensor product, complex tensor product, transpose, complex transpose, polynomial roots
Statistical	Gaussian distribution, random distribution, random real distribution, arithmetic mean, standard deviation of sample, standard deviation of population, binomial distribution*, exponential distribution*, gamma distribution*, lognormal distribution*, geometric distribution*, Poisson distribution*
Queue manipulation	Initialize queue, get and put from queue front, get and put from queue rear, length of queue, peek at nth member*, get nth member*, set nth member*
Dynamic arrays	Make dynamic array, get array dimension, dispose dynamic array
Dialog box	User error dialog box, user prompt dialog box, beep, help dialog box, open block's dialog box*, close dialog box*, speak a string using Macintalk*
Time and date	Get current time and date
Financial	Calculate present value, future value, number of periods, payment, and interest rate
Plotting	Install axis, get axis, get signal value, plot new point, remove signal, retime axis, show plot, dispose plot, autoscale x*, autoscale y*, plot signal format*, make scatter plot*, plot new scatter point*
Array passing*	Pass array to connector or global variable, get passed array
Bit functions*	Bit set, bit clear, bit and, bit or, Bit xor, bit not, bit shift, bit test
Complex math*	Add complex numbers, divide complex numbers, multiply complex numbers, subtract complex numbers
Device driver*	Open driver, close driver, read from driver, write to driver, send control code, get device status, terminate operation
File I/O*	Open file, read from file, get delimiter, check end of file, close file, create new file, write to file, rewind file
Import/export*	Import from path name into array, export from array to path name
Serial I/O*	Configure serial port, read from serial port, write to serial port
String*	Length of string, get substring, find substring, replace substring, convert from integer to ASCII
Timing*	Get current tick count, wait for N ticks
Worksheet inquiry*	Get number of blocks in worksheet, get name of block, get number of block

*Version 1.1 enhancements.

Modeling with ModL

Because it looks like C, ModL is easy to learn. However, ModL is insensitive to case, uses two asterisks for comments, and supports the keyword `real`, as opposed to C's `float`, and it doesn't support the `++` operator. It annoyed me a bit, but it might not bother you.

Table 1 lists some of ModL's built-in functions. You can augment that list with functions that you write in ModL. Unfortunately, the scripts for these are not separable from the block script in which

they appear, so you can't reuse them as conveniently as you can entire blocks. A library manager for functions would be a welcome addition; so would a debugger. ModL doesn't support pointers, and it won't let you touch memory directly, so you can't get into too much trouble. You can usually debug a script by examining its output. But whenever I find myself inserting print statements into code, which is what happened while experimenting with ModL, I yearn for a source-level debugger.

Blocks can't receive and act on user-defined messages, as objects in HyperTalk scripts can, and they can't inherit behavior as Smalltalk objects do. Such features aren't necessary for the kinds of things most people want to do with ModL, but they would make life easier for model writers.

Extend performs well for small to medium-size models with five to 10 blocks. There's a noticeable degradation of performance when models become large

continued

and contain dozens of blocks, which made me appreciate my 68020 accelerator. But you have to keep things in perspective. Extend is a drawing program, a programming language compiler, a plotting package, a resource editor, and a mathematical function library. Extend's drawing functions are probably slower than those in MacDraw II. Extend's compiler probably compiles more slowly than Lightspeed C. There are undoubtedly faster plotting programs and re-

source editors. But there isn't another Macintosh application that better integrates the tasks required to construct simulation models.

The steepness of Extend's learning curve varies with a user's level of experience with simulation, programming, and the Macintosh. Accordingly, it might take you weeks to become proficient, or it might take you just a few days. Once you have mastered the necessary skills, though, you can create non-

trivial working simulations in very short order.

Managing Complexity

To stretch the capabilities of the program, I used Extend's cut-and-paste facility to expand my traffic model. With 50 blocks in the model, performance slowed noticeably, but it was still acceptable. What limits Extend isn't performance but comprehensibility. A large Extend model suffers from the same problems as a large spreadsheet. Because you can't hierarchically decompose structures, things can get confusing. A single element in a model can't represent a subsystem, and it can't link to a sub-model in a separate worksheet. Everything in a model exists on a single level, such as a set of blocks situated in a large two-dimensional workspace.

Because of this limitation, Extend is definitely not suited for the simulation of systems with hundreds or thousands of components. The ability to structure models hierarchically would be a big improvement.

Although Extend generally takes advantage of the Macintosh interface, there are a few anomalies. For example, when the cursor traverses a worksheet, it changes according to the object you point to. If you point to a block, the cursor represents a hand, indicating that you can drag the block to another position. If you point to some text, the cursor changes to a text caret, which means you can edit the text. Macintosh programs don't usually handle modal changes that way—though it's a convenient and arguably better method. Instead, they provide a palette of tools (e.g., to enter text mode, you select the text tool from the palette).

Extend is to professional simulation work what desktop publishing programs are to the graphic arts: It's a personal computer program suitable for small- and medium-scale work. As in desktop publishing, there are high-end jobs for which PC-based programs are not appropriate. This does not mean the program should not be taken seriously. If you already do simulation modeling, it will significantly improve your productivity. And if you are new to simulation and would like to model a problem in business, science, or engineering, you should take a close look at Extend. ■

Ray Valdés is president and founder of Sapphire Software, a technology consulting firm in San Francisco, California, that specializes in the design and development of graphics software. He can be reached on BIX c/o "editors."

WHY DESIGN YOUR PRODUCT AROUND A COMPUTER?

Design the computer in.

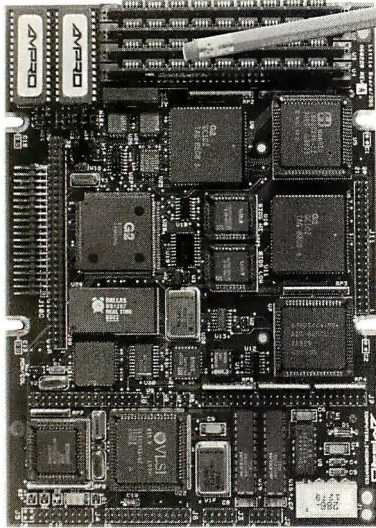

Little Board™/286

Built-in vs. built-around. External systems mean boxes, boards, backplanes, cables, and reliability problems. Ampro's Little Boards give you a complete system on a single board you can build right into your product.

Small size. Big power. Eliminate the bulk and constraints of multi-board, backplane-based systems. Embed a Little Board that requires just 2/3rds the power and volume of a 5 1/4" floppy drive. But with the full power of a PC or AT®.

Fully compatible. Little Board/286 and Little Board/PC are functionally identical to multi-board PCs and ATs. They run PC-DOS™ 2.0 to 3.X. They run DOS languages, compilers and applications. You'll be standing on a proven foundation of hardware and software.

Ampro's Single Board Systems. It's all there. Up to a Megabyte of RAM. RS-232C and Parallel ports. AT/PC-compatible controllers and bus expansion. EGA/CGA/MDA and Hercules™.

Reps: Australia—61 3 720-3298; Austria—43-222/45 45 01; Canada—(604) 438-0028; Denmark—45 3 66 20 20; Finland—358 0 585-322; France—331 4502-1800; Germany, West—49 89 611-6151; Israel—972 3 49-16-95; Italy—39 6 811-9406; Japan—81 3 257-2630; Netherlands—010-411 85 20; Spain—M34 3 204-2099; Sweden—46 8 55-00-65; Switzerland—41 1 740-41-05; United Kingdom—44 2 964-3551; USA—contact AMPRO

Trademarks: IBM, AT—IBM Corp.; Hercules—Hercules Computer Technology, Inc.; Little Board—Ampro Computers, Inc.; DR-DOS—Digital Research, Inc.

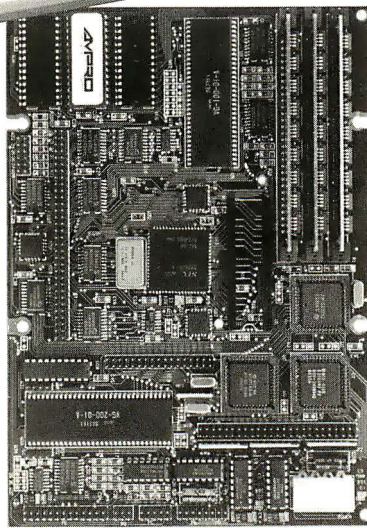

Little Board/PC

compatible video options. Even optional solid-state disk. Plus SCSI support for hard disk, tape, optical drives, bubble drives... you name it. And, low power consumption (+5VDC, less than 8W) and a wide operating temperature range (0 to 60°C). Perfect for standalone operation and harsh environments.

Anywhere that reliability is a critical consideration. **Available worldwide.** For information and the name of your nearest U.S. or international Ampro representative, call us at the number below. Or write for Little Board Product information.

Now includes DR-DOS™

408-734-2800

Fax: 408-734-2939 TLX: 4940302

AMPRO
COMPUTERS, INCORPORATED

1130 Mountain View/Alviso Road
Sunnyvale, CA 94089

Knowledge, Experience & Expertise your most valuable resources.

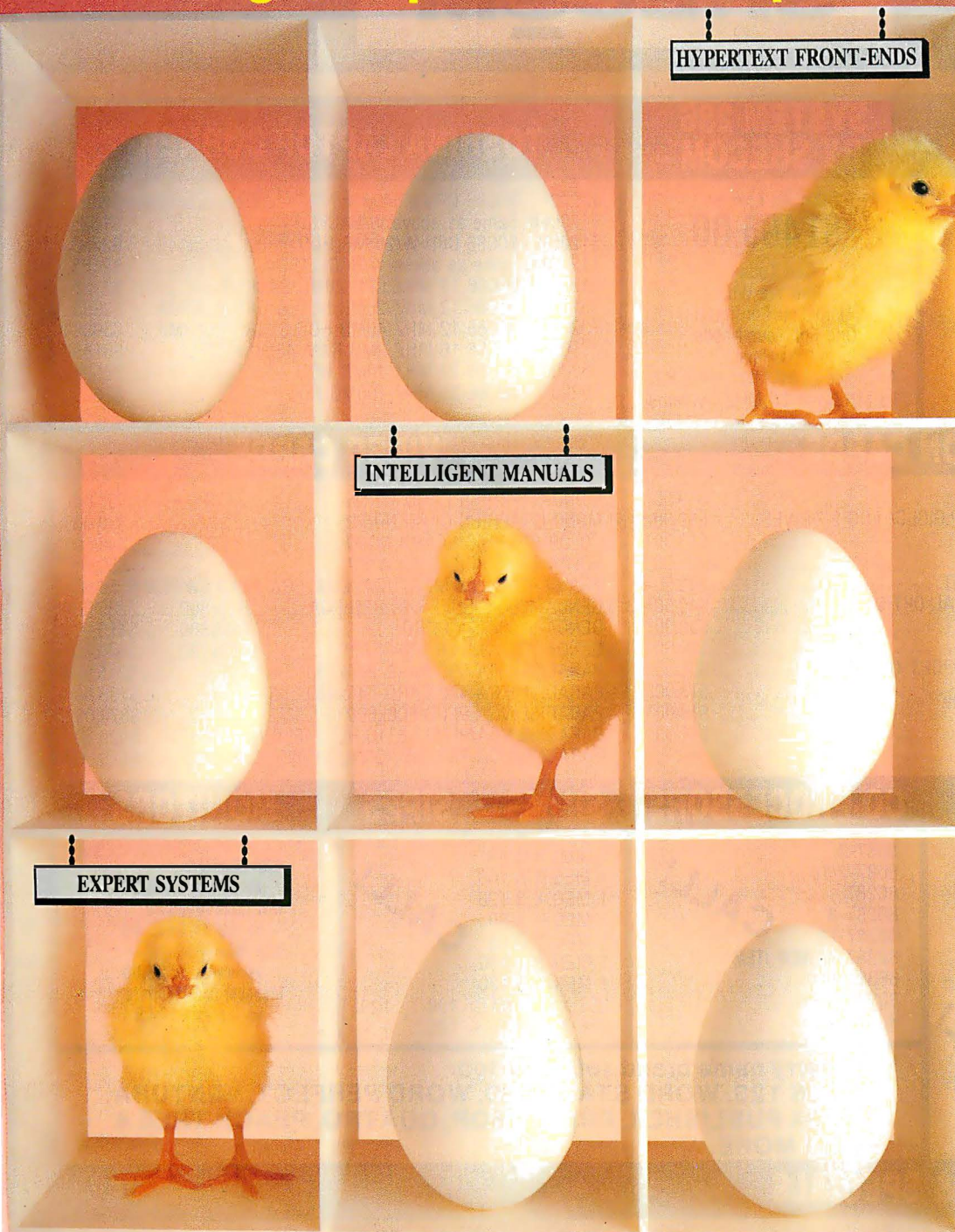

Now available on the IBM PC!

KnowledgePro® is a tool for "explaining things" using a computer. It combines HYPERTEXT and EXPERT SYSTEM technologies in a high-level language to let you write stand-alone applications or add an intelligent, aesthetic interface to your existing programs.

KnowledgePro stores knowledge in natural "chunks" called topics. It lets non-programmers communicate complex information using simple commands like SAY, ASK, IF, DO and PICTURE.

KnowledgePro lets you integrate hypertext, rules, math, lists, and logic quickly and easily. With our Database Toolkit you can read Lotus 123 and dBASE III files. The Graphics Toolkit lets you define hypergraphics using PC Paintbrush images. The VideoDisk Toolkit provides complete control of interactive laser video.

KnowledgePro reads, writes and searches text files. You can include routines written in other languages and call other programs.

Your **KnowledgePro** application can ask users for information you need to bring together resources and explanations they need. You can retrieve text, graphics, data, and video information, perform calculations, create text files and run programs based on each user's unique problems, interests and level of expertise. "I recommend that you check out **KnowledgePro**", said Steve Ciarcia of BYTE. "So much fun to work with", said Mickey Williamson in PCWEEK. "I LOVE **KnowledgePro**. It's less like programming and more like writing", said Dan Shafer of PC AI.

KnowledgePro runs on IBM PC XT, AT and PS/2 compatibles with 640k. It costs \$495 plus \$8 shipping (\$58 foreign). There are no run-time charges, so you don't have to pay more to distribute applications. The Database, Graphics and VideoDisk Toolkits cost \$49, \$89 and \$249 respectively. **KnowledgeMaker**, our induction system for creating rules from data, costs \$99. **Stock Expert**, a system for the personal investor, costs \$249. A working demonstration system, with a 100 page manual, is available for \$30 plus \$5 shipping (\$8 foreign) with credit toward purchase of the full system.

For product literature, review reprints or to order:

Call 518-766-3000
(FAX 518-766-3003)

Amex, M/C, Visa, COD or send check to:
Knowledge Garden Inc., 473A Malden Bridge Rd.
Nassau, NY 12123, USA.
New York residents please add 7% sales tax.

KnowledgePro®
A tool for communicating knowledge
by **Bev & Bill Thompson**

Join us on CompuServe (GO PCVEN user option #8)

Circle 146 on Reader Service Card

from



KnowledgePro is a trademark of Knowledge Garden. IBM, dBASE III, Lotus 123, CompuServe and PC Paintbrush are trademarks of their respective corporations. Photo Tcherevkoff ©

SHECOM

SHECOM XT TURBO SYSTEM

8088 10 MHz CPU
256K RAM
One 360K FDD
Serial/Parallel Ports
84 Keyboard
12" Amber Monitor
Real Time Clock
2 Year Limited Warranty
ONLY **\$545.00**

SYSTEM 286 BY SHECOM

Start As Low As
\$1495.00
Call Today
And We Will
Help You Configure
One For Your Needs.
You Have
A Choice of 10 MHz, 12 MHz,
16 MHz and 20 MHz Systems

TOSHIBA LAPTOP CORNER

T1200F	80C86 CPU 9.54 or 4.77	\$1395
T1200FB	Same as above W/BACKLIT	\$1625
T1200H	80C86 CPU W/20 MB HOD	\$2395
T1200HB	Same as above W/BACKLIT	\$2585
T1600	80C86 12 MHZ CPU 20MG/BACKLIT	\$3325
T3100E	80C86 12 MHZ 20MB HOD & GAS PLASMA	\$2995
T3200	80C86 12 MHZ 40MB HOD & GAS PLASMA	\$3995
T5100	80C86 16 MHZ 2MB RAM 40MG HOD	\$5185
T5200	80C86 20 MHZ 40MG HOD	\$6595
T5200	80C86 20 MHZ 100MG HOD	\$7675

ADD ON CARDS

XT I/O PLUS II S/P.G.CLC.	\$49.50
XT MULTI I/O 1/2 CARD S.P.G.CLC/ FDC 2 DRIVES	\$59.00
XT MULTI I/O SERIAL KIT	\$13.00
XT MULTI I/O W/VIDEO	\$110.00
AT SERIAL/PARALLEL CARD	\$38.50
AT I/O CARD S/P/2ND SERIAL OPTION	\$40.50
AT 2ND SERIAL KIT	\$20.00
RS232 CARD 1 PORT	\$22.00
RS232 CARD 2 PORT (2ND PORT OPTIONAL)	\$30.00
RS232 2ND SERIAL PORT	\$13.00
GAME CARDS	\$14.00
PRINTER CARD	\$16.50

VIDEO CARDS

MONO GRAPHICS CARD W/PP	\$55.00
MONO GRAPHICS CARD NO/PP	\$50.00
COLOR GRAPHICS CARD NO/PP	\$48.50
COLOR GRAPHICS CARD W/PP	\$50.60
EGA CARD FULLY MGA, HGA, CGA, EGA AUTO SWITCH	\$155.00
GENOA 4880-7 SUPER HI RES EGA, 800x800	\$235.00
GENOA 5100-VGA CARD, 800x800	\$415.00
GENOA 5200-SUPER VGA CARD, 1072x780	\$540.00
PARADISE EGA 350 CARD 640x350	\$215.50
PARADISE EGA 480 CARD 640x480	\$235.50
PARADISE VGA PLUS 800x600	\$370.00
PARADISE VGA PLUS 16, 16 BIT 256KB MEMORY	\$420.50
PARADISE VGA PROFESSIONAL 512KB MEMORY	\$570.00

DRAMS

1 MEG x 1 - 80 NS
1 MEG x 1 - 100 NS
1 MEG x 1 - 120 NS
256K x 1 - 60 NS
256K x 1 - 70 NS
256K x 1 - 80 NS
256K x 1 - 10 NS
256K x 1 - 12 NS
256K x 1 - 15 NS
64K x 1 - 10 NS
64K x 1 - 12 NS
64K x 1 - 15 NS

CALL!

CO-PROCESSORS

8087-3
8087-2/10
80287
80287-8
80287-10
80287-12 NEW ITEM
80387-15
80387-20
80387-25

CALL!

SIMMS / SIPPS

1 MEG X 8 80
1 MEG X 8 100
1 MEG X 8 120
1 MEG X 9 80
1 MEG X 9 85
1 MEG X 9 100
1 MEG X 9 120
258 X 9 80 100 120
258 X 8 80 100 120

CALL!

MONITORS

EGA Monitors
as low as \$445.00
Multisync Monitors
as low as \$475.00
VGA Monitors
as low as \$525.00
Monochrome Monitors
as low as \$80.00

We carry name brand software too:

LOTUS 123, WORD STAR 2000, WORD PERFECT, VENTURA, XEROX PUBLISHER, PRINT SHOP, QUATRO, PEACH TREE & MANY MORE.

ACCESSORIES & SPECIALS

MOUSES ARE HERE TO STAY!

KRAFT MOUSE Reg \$70 NOW \$58
LOGITECH SUNAL Reg \$85 NOW \$70
LOGITECH BUS MOUSE \$99
LOGITECH HI RES MOUSE \$110
SUMMASKETCH 12x12 \$485
LOGITECH HANDY SCAN \$225
PANASONIC SCANNER 300 x 300 DPI \$1,000

JOIN
THE SHECOM
CLUB FOR ONLY
\$25.00
AND SAVE
\$\$\$

SAMSUNG INT 1200 MODEM	\$85
SAMSUNG EXT 1200 MODEM	\$120
SAMSUNG INT 2400 MODEM	\$150
SAMSUNG EXT 2400 MODEM	\$195
SMART ONE INT 1200 MODEM	\$75
MASTER COM INT 2400	\$140
THE COMPLETE 9600 FAX CARD	\$510
THE COMPLETE FAX 4800	\$335
NITSUKI FLAT BED FAX Reg. \$850	\$750

SHECOM COMPUTERS, INC.
22755-G Savi Ranch Parkway
Yorba Linda, CA 92686
FAX: (714) 637-6293

Call before you buy and
SAVE! SAVE! SAVE!

Most orders shipped within 48 hours or less
HOURS
M-F 8 a.m.-6 p.m. SAT 11 a.m.-3 p.m.

Ask for our Desktop Publishing
CAD/CAM/CAE System Packages
PACIFIC TIME
Prices subject to
change without notice.

INQUIRIES 714-637-4800

Circle 259 on Reader Service Card (DEALERS: 260)

TECH SUPPORT 714-637-5921

SALES ORDERS CALL

1-800-366-4433



Mac Desktop Presentation Software

Three graphics packages
that give you
the power of persuasion

Lawrence Stevens

Unless you're one of the lucky few who can keep an audience at the edge of its seat with your rhetorical ability (or your good looks), you probably depend on flip charts, transparencies, and slide shows to complement your verbal presentations. And unless you're a whiz with stick-on letters, your organization's art department or outside sources probably help you create those presentations. But you could use your Macintosh.

Three programs I looked at, StandOut! 1.0, PowerPoint 2.00A, and Cricket Presents 1.0, let you do just that on a Mac Plus or larger system. They combine text and graphics capability along with other features that help you organize and display your presentations.

One of the most interesting features of these programs is their ability to display all the presentation's frames in reduced form on the screen at once, much like a light table displays a set of slides. (A "frame" can be an individual slide, a flip-chart page, or a transparency.) This lets you get an overview of the entire presentation, and you can see how both the ideas and design of each frame fit with adjacent frames. You can easily rearrange frames to make the presentation flow nicely.

Another interesting aspect of these programs is that they automatically create handout and note pages for each presentation. A handout page contains two to eight reduced frames that you can

distribute to your audience. The note page has one reduced image of each frame per page, along with a space for the speaker's notes.

Of course, one of the biggest advantages of these desktop presentation programs is that they let you use the Mac itself as a display device. In this mode, software tools such as the menu bar and scroll bars disappear, and the presentation's frames are displayed consecutively as they would be in a slide show. The frames change each time you click the mouse button, or you can specify how many seconds each frame will appear on the screen before it is replaced with the next one.

You can create a set of transparencies with a laser printer or have your printing house create slides or transparencies from your printed output. Cricket Presents and PowerPoint also provide a service for turning your frames into 35mm slides. You send files by modem or mail, and the slides are produced within 24 hours.

Text Handling

Most presentations are primarily made up of text, and all three programs have features that let you easily enter text and format the style and size of the characters. But PowerPoint and StandOut! provide more options for sprucing up text with borders and background patterns and for joining text to other elements of the frame. Once you create text in these packages, it is treated like any graphics element; you can fill it in, or you can give it a border of any pen size, pattern, or color. Cricket Presents provides the least graphical control of text in that it does not let you create any graphics elements, such as borders, directly around text.

In PowerPoint, you can also attach text to any object, such as a square or a circle, by first creating the object with a drawing tool and then typing the text you wish. The text will appear within the object with the alignment, font, style, and

type that you choose. You can opt to have any overflow text run outside of the object, or you can have the object resize itself to accommodate the length of the text. Of course, all three programs let you place text inside a graphics element by first using a graphics tool, then using a text tool, and finally grouping the graphics and text. But PowerPoint's process is simpler.

Besides its text tool, PowerPoint has a labeler tool that lets you enter text without creating a text box. Text boxes, which are used by all three programs but are optional with PowerPoint, define the area where the text will appear. Since the labeler tool does not define any area, it's much quicker to enter text that does not have to be confined to a specific section of the frame.

While PowerPoint is strongest in combining text with graphics, StandOut! provides the most control over typographical elements. All three programs let you specify normal typing attributes such as superscript, subscript, and tabs. But in StandOut!, you can perform typesetting-like functions such as shifting characters up or down any number of points, kerning, and specifying line spacing or space between words or letters.

Both StandOut! and PowerPoint let you create style sheets in which you can save complicated text formats and then apply them with a few keystrokes. PowerPoint's style sheets are slightly easier to use because they appear in submenus, and you can apply them with option/letter commands. On the other hand, style sheets in StandOut! are listed in a separate window. StandOut! also includes a glossary function. Both programs have find-and-replace functions as well as spelling checkers.

Cricket Presents and StandOut! can also align or center objects on the page. You can center or align objects vertically or horizontally by their top, bottom, or left or right side.

continued

	StandOut! 1.0	PowerPoint 2.00A	Cricket Presents 1.0
Type	Graphics package	Graphics package	Graphics package
Company	Letraset USA 40 Eisenhower Dr. Paramus, NJ 07653 (201) 845-6100	Microsoft Corp. 16011 Northeast 36th Way P.O. Box 97017 Redmond, WA 98073 (206) 882-8080	Cricket Software 40 Valley Stream Pkwy. Malvern, PA 19355 (215) 251-9890
Format	Three 800K-byte floppy disks	Three 800K-byte floppy disks	Six 800K-byte floppy disks
Hardware Needed	Mac Plus, SE, or II (a Mac II with 2 megabytes of RAM and a color monitor is recommended)	Mac Plus	Mac Plus
Software Needed	Any version of System	System 4.1 or higher	Any version of System
Language	C	C	C
Documentation	265-page manual; 36-page design guide; 26-page tutorial; 16-page quick reference guide	360-page manual; 5-page Using PowerPoint Genigraphics Presentation Services; 16-page SmartScrap manual; 28-page quick reference guide; 60-page Using PowerPoint Templates	244-page manual; 74-page reference manual; 16-page Using Templates and Color Palettes; 9-page release notes; 20-page autographix manual; 54-page Acta user's manual
Price	\$295	\$395	\$495
	Inquiry 886.	Inquiry 887.	Inquiry 888.

StandOut! is the only one of the three packages that allows runaround text. If you specify runaround text for any graphics element, the text that overlaps the element will also surround it. You can even specify how close the text should come to the object.

Charts and Graphics

All three programs let you cut and paste charts created by other programs. But StandOut! and Cricket Presents can also generate charts. Both programs have the full range of charts: bar, column, scatter, area, line, and pie. And each program gives you wide latitude in formatting the elements of the chart. You can change the order of the data and specify the size of lines and fill patterns. You can also add and remove labels and switch from one type of a chart to another.

You enter the data for these charts into a data sheet that looks like a spreadsheet. But unlike a spreadsheet, the data sheet does not accept formulas, so you have to do any calculations manually.

StandOut! lets you import data directly from an Excel worksheet into its chart data sheet, so you can have Excel do the calculations for you. The Excel data must be in a specific format (i.e., alphanumeric data and numeric data in specific columns), but the format follows a spreadsheet's typical arrangement anyway.

You can create tables of data in any of these programs using tabs along with lines and boxes created with the drawing tools. But Cricket Presents makes this task easier by providing a specific Table tool where you enter data in boxes and then format the table any way you want.

All three programs also have a drawing capability, but Cricket Presents is the most fully featured. It has a total of 10 drawing tools, including line, arc, rectangle, rounded rectangle, polygon, and freehand. By contrast, StandOut! has eight and PowerPoint has only four. Neither StandOut! nor PowerPoint provide tools for rounded rectangles and freehand drawing. And PowerPoint is particularly limited in that you can't create such standard shapes as diamonds, parallelograms, and arcs.

Imported Graphics

You can create an entire presentation with only the tools contained in the presentation software. But you may find that you need to import text or complicated images from other applications. All three programs let you import graphics images directly from most Mac drawing files, such as PICT, PICT II, Encapsulated PostScript Format, and MacPaint.

Just in case your graphics files are very large, which is often the case with 256-color files, Cricket Presents has a way to eliminate the memory and speed

problems that often result. Any imported files that are over 32K bytes are not really transferred into a Cricket Presents frame. Instead, they remain on the disk, hot-linked to the appropriate frame. When working on the frames, you can see a symbol on the screen that represents the image. You can resize and move the symbol and then get a description of the image by double-clicking on the symbol. When you run a slide show on the Mac or print the file, the program retrieves the image from the disk.

To use images created with software that can't be directly imported, you must cut and paste from one application to another. If you don't have MultiFinder or Switcher (or the large amount of memory required to run them), the only reasonable way to do this is through the Scrapbook. PowerPoint comes bundled with SmartScrap, an improved Scrapbook that gives you a table of contents and lets you scroll to see all the image, copy and paste selected parts of the image, and have multiple Scrapbook files.

PowerPoint lets you import files directly from More or ThinkTank, two powerful stand-alone outliners for the Mac. When you import a file from either of these programs, PowerPoint automatically creates a new presentation from the outline. The first frame of the presentation contains a list of the main topics in the outline. Each frame after that con-

tains one main topic and all the subtopics indented in the same format as the text in the outline. You then can use all the PowerPoint tools to modify the presentation.

Cricket Presents comes bundled with Acta, a powerful desk accessory outliner. Since it is a DA, it can appear on your screen along with Cricket Presents so that you can easily cut and paste from one to the other.

Elements of Design

After creating a number of presentations, you'll probably find that many of your frames use the same design elements. You can use templates to save your commonly used forms, including the text style, color, layout of objects, and background elements such as logos. You may have some templates that contain the complete frame design, while others may contain formats for only part of a frame, such as placement of text or graphics, background color, or layout of a table. You can either add elements to these partial templates or combine two or more templates to create a complete frame.

While the most useful templates will be those you create yourself, all three programs come with templates to get you started. PowerPoint has over 100, and Cricket Presents and StandOut! have about 50 each.

Each of the programs organizes templates in different ways. The method used by Cricket Presents is the most convenient. It lets you view all templates on your disk through a window that displays the template name, a 2-inch square image of the template, and any notes you may want to make about it. When you find a template you want to use, a simple mouse-click automatically pastes it into the frame you are working on. PowerPoint and StandOut! save templates in separate files. To use these templates, you have to open the file, view the templates, choose the one you want, and then copy and paste it into your frame.

All three programs can generate presentations in either monochrome or color. Obviously, the best machine for creating color output is a color Mac II. But even if you have a Mac Plus or SE, you can use the eight colors available to (but not visible on) those computers to create acceptable color presentations. I found eight colors adequate for just about any presentation.

PowerPoint also comes with color schemes. These contain eight colors that are chosen for their aesthetic compatibility. When you switch from one color scheme to another, the colors of all the

If you
just want to copy and
paste text or graphics
from other applications
into frames, any of
these programs will do.

elements, background, text boxes, and so on will also change. In that way, you can view your presentation in different colors while being sure that all the colors will be compatible.

The Big Picture

If all you want to do is copy and paste text or graphics from other applications into frames for your presentation, any of these programs will do. But to do more than that, each program has strengths that optimize it for different types of work.

For creating graphics and charts, Cricket Presents is the best, with StandOut! a close second. Both programs have a full range of drawing tools, but the rhomboid and polygon drawing tools, both of which are unique in Cricket Presents, may come in handy. Similarly, if you need stacked bar, line, or area charts, Cricket Presents is your only choice.

Both PowerPoint and StandOut! have strong text resources. But PowerPoint, with three text tools rather than one, makes text entry easier. PowerPoint's ability to let you enter text without first having to create a text block can make labeling objects and placing floating text around a frame very easy. Both PowerPoint and StandOut! also have spelling checkers, which can save you from embarrassing moments.

If you find yourself needing the more precise text measurements normally found in page layout programs, StandOut! is a better choice. It gives you more control over such things as line and letter spacing, and it also has style sheets and glossaries to speed up input. ■

Lawrence Stevens is a freelance writer based in Springfield, Massachusetts, who prepares presentations for Holyoke Community College. You can reach him on BIX c/o "editors."

SOLUTIONS

Bigger—

*Vfeature Deluxe*TM lets your DOS system use hard disks it thought it couldn't, all in one bootable piece—no artificial partitions! You can even span your old drive with the new one for more capacity. Use RLL, ESDI, or SCSI, and laugh at DOS partition limits. \$120

*DUB-14*TM takes a different approach to drive expansion, stretches your AT's Drive Table to support the drive YOU choose! Comes with setup and low-level format routines, and it's OS independent. \$95

Faster—

*Vcache*TM accelerates disk operations, avoids repetitive accesses by storing data in RAM as you read it so it's there for you the next time you need it—no waiting! Works with any type of memory, caches up to 15 Mb, bundles accelerators for your diskettes, screens, and keyboard. \$59.95

*Vopt*TM saves head motion by eliminating DOS file fragmentation. In a few seconds at boot time, *Vopt* arranges all your files neatly in contiguous clusters so you won't waste any time reading them back. Bundles timing and diagnostic utilities. \$59.95

Safer—

*Vlock*TM protects your system and its data from vandals and accidents. System access passwords control booting, activity menus decide who does what to which files, even locks out Ctl-Break during boot! \$135

Easier—

*Vtools*TM is a slick set of disk management tools for DOS and OS/2. Display directories in whatever order you like, browse files and change or delete them, compare and update multiple versions, find and manipulate categories of files, and more! \$49.95

SEE YOUR DEALER OR CALL TOLL-FREE

1 (800) 284-3269



GOLDEN BOW SYSTEMS

2870 5TH AVENUE

SAN DIEGO, CA 92103

(619) 298-9349

FAX (619) 298-9950 TELEX 201520 GBS UR

MC/VISA US shpg/hdlg \$3 CA orders add 7%

Vfeature, DUB-14, Vcache, Vopt, Vlock, and Vtools are trademarks of Golden Bow Systems.

CASE

- 209 The CASE Philosophy**
by Michael Lucas Gibson
- 221 Methodology: The Experts Speak**
by Ken Orr, Chris Gane, Edward Yourdon, Peter P. Chen, and Larry L. Constantine
- 235 The CASE Experience**
by Carma McClure
- 246 A CASE Workshop**

CASE, or computer-aided software engineering, is a *tool* for programmers, analysts, and systems engineers, as well as for business planners and executives at all levels and for businesses of all sizes, shapes, and structures. To quote Carma McClure, "CASE is software automation." It provides software tools to help corporate planners plan, and to document their work; to support systems analysts in analyzing and designing systems, and to document those tasks; and to take some of the drudgery out of programming while documenting it.

Sounds better than sliced bread, doesn't it? If it is, why haven't you heard more about it from BYTE? Because until recently, CASE tools cost in the five- and six-figure price range and only ran on mainframes. Now, the majority of them run on microcomputers, and many are available for less than \$1000.

So, this month we introduce CASE, BYTE-style. The In Depth section has among its authors some of the top people in the field. We begin with "The CASE Philosophy" by Michael Lucas Gibson. This article introduces the concepts and capabilities of CASE and explains what the different elements of CASE are and what they are for. CASE itself is modular, and you may find that some parts of it fit your environment while other parts do not.

You can't talk about CASE without discussing methodology. In a field based on structured methods, there are an amazing number of different approaches to that structure. In the article "Methodology: The Experts Speak," some of the

gurus of various methodologies present the approaches for which they are known. This article contains "The Warnier/Orr Approach" by Ken Orr, "The Gane/Sarson Approach" by Chris Gane, "The Yourdon Approach" by Edward Yourdon, "The Entity-Relationship Approach" by Peter P. Chen, and "The Structured Design Approach" by Larry L. Constantine.

In addition, "The CASE Experience" by the renowned CASE authority Carma McClure discusses some of the various CASE tools, toolkits, and workbenches available today for microcomputers—what they do, what CASE functions they deal with, and how they fit into the whole picture. She also includes three CASE success stories. Finally, she provides our resource guide this month, "A CASE Workshop," with a list of contact information for the products discussed in her article.

—Jane Morrill Tazelaar
Senior Technical Editor, In Depth

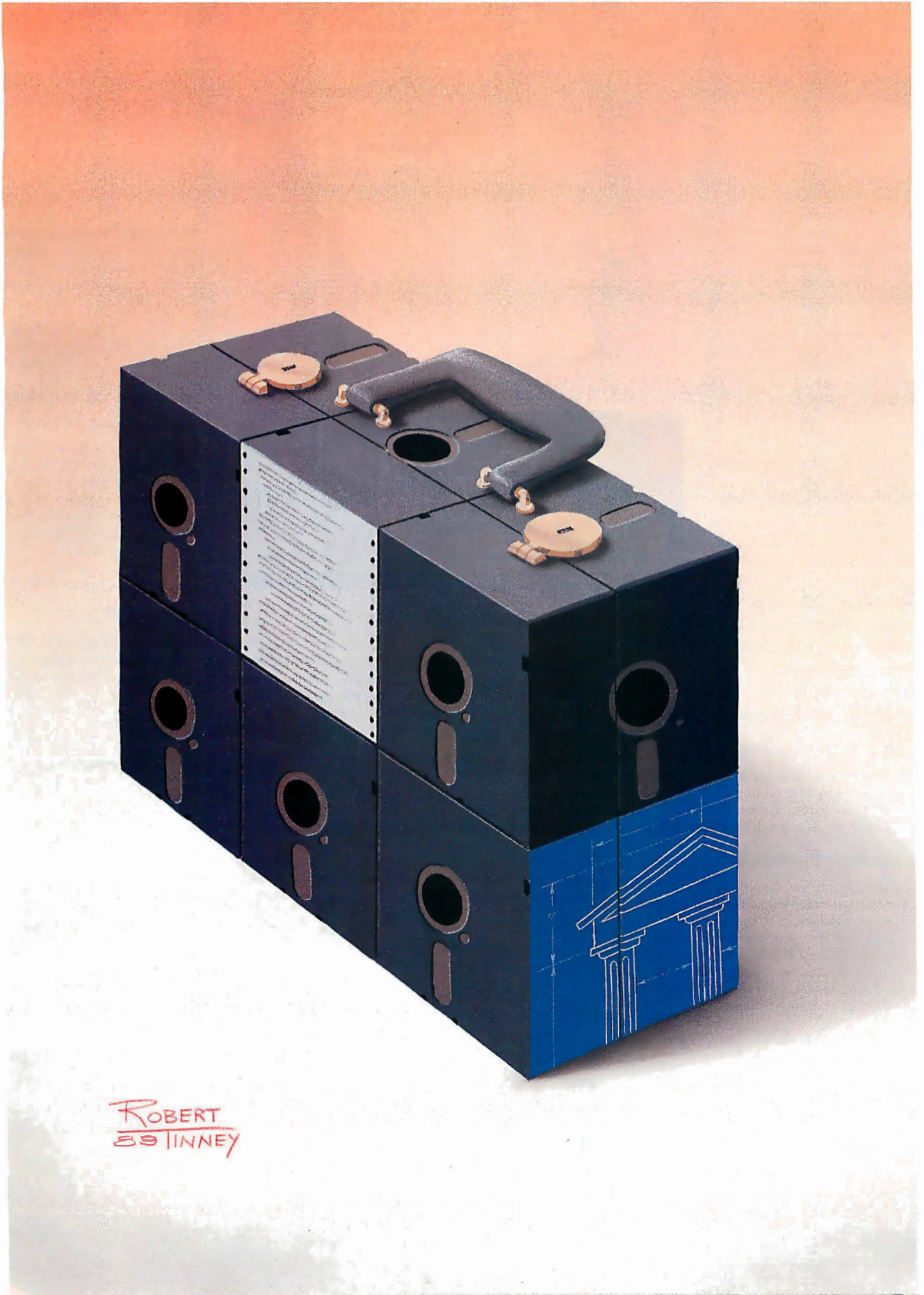

ROBERT
TINNEY

Automate the critical task of Configuration Management with easy to use and highly flexible tools from POLYTRON. You will discover why thousands of programmers and managers at the leading software, aerospace, manufacturing and service companies use the POLYTRON Version Control System (PVCS™) and PolyMake™ to control the revisions and versions of source code and automate the rebuilding process with unequalled power and precision. PVCS and PolyMake can be used independently or together.

“In terms of features, PVCS provides everything necessary to a large multi-programmer project — more than any other package reviewed ... all aspects of operation can be customized for specific project needs.”

PC Tech Journal

Unmatched Capabilities

- Storage & Retrieval of Multiple Revisions of Source & Binary Code
- Maintenance of a Complete History of Changes
- Source Code Access Control
- Optional Merging of Simultaneous Changes
- Release and Configuration Control
- Project Activity Reports
- Management Reports
- Control of Separate Lines of Development (Branching)

For Simple & Complex Projects

Automatically rebuild and maintain simple or highly complex projects consisting of thousands of modules, multiple directories & disks, and geographically dispersed development locations.

Multiple Platform Development

If your projects are developed in a multiple operating system environment, or will be ported to run on another OS in the future, PVCS and PolyMake will make your job easier. The PVCS archive files (logfiles) and the command interfaces are exactly the same across operating systems. The same PolyMake makefiles can run unchanged on the different operating systems.

Supports ANY Language

PVCS maintains individual archives of all project components in your system — source code modules, data files, documentation and even object code. The “source documents” can be written in any language or multiple languages. PolyMake is also language independent.

Call About Our OEM/VAR Strategic Alliance Program

MS-DOS OS/2 Macintosh

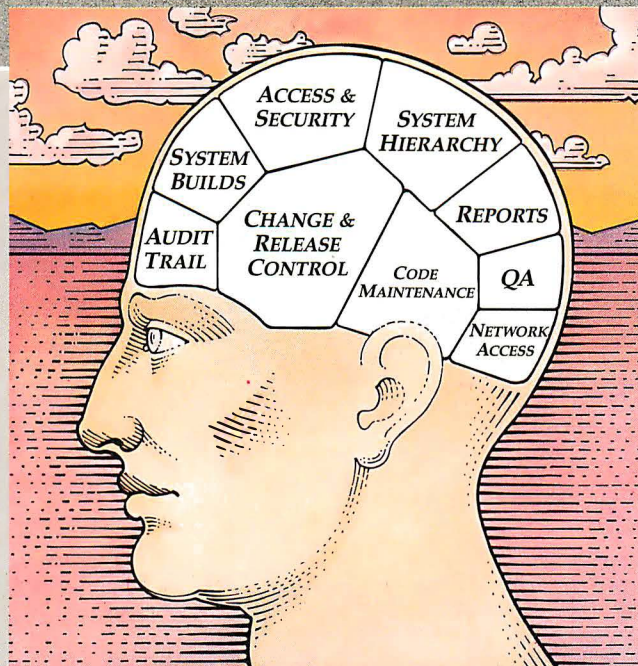

**Change Control
Made Simple.**
Configuration Management On Single
Or Multiple Operating System Projects.

Fast Retrieval of Revisions

PVCS uses “reverse delta storage” which saves disk space and speeds retrieval of the latest versions of any module or an entire system. A delta is the set of differences between any revision and the previous revision. Differences are automatically detected and stored when programmers “check in” a file.

A Practical Necessity for LANs

While important for single-programmer projects, PVCS is absolutely essential for multiple-programmer projects and LAN-based development efforts. In a LAN environment, source code modules are simply too easy to change. Because any change to any module can have major ramifications, coordinating and keeping a record of changes is critical. Project leaders can determine on a module-by-module basis, which programmers can access or modify source files, libraries, object code or other files. Levels of security can be tailored to meet the needs of nearly every project. PVCS works on all major LANs and networks, including networks with multiple computer types.

The Leading Change Management System

The World's Best Selling Build Utility

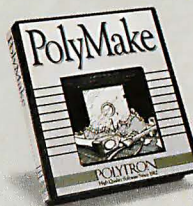
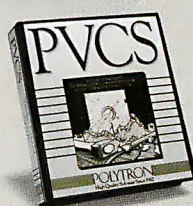

PolyMake Works With PVCS

PolyMake understands the structure of PVCS logfiles and is able to correctly determine the time and date of any module revision. This prevents unnecessary operations that occur when the date and time of the revision archive file itself is used as with other Make utilities.

The Price AND Performance Leader

POLYTRON products are priced on a “Per User” basis. The price per user decreases as you add users. ■ **MS-DOS, Macintosh MPW: Personal PVCS** (for single programmer projects) \$149 for single user. **Corporate PVCS** (has features for larger, more complex projects including unlimited levels of “branching”) \$395 for single user. **Network PVCS** (includes file locking and security features for LAN use) \$1,284 for 5 users. **PolyMake** \$149. **Network PolyMake** \$484 for 5 users. ■ **PVCS and PolyMake are packaged together on OS/2, SunOS and VAX/VMS.** ■ **OS/2:** \$695 single user, \$2,259 for 5 users. ■ **SunOS:** \$795 single user, \$2,584 for 5 users. ■ **VAX/VMS any model:** \$995 single user, \$3,233 for 5 users. ■ Call for price quotes.

30 Day Money Back Guarantee

TO ORDER: 1-800-547-4000

Ask for Dept. BYT. Send Checks and P.O.s To: POLYTRON Corporation, 1700 NW 167th Place, Beaverton, OR 97006. FAX (503) 645-4576, TELEX 325800 POLYTRON

VAX/VMS

SunOS



“PVCS has helped us maintain nearly 90 programs and utilities. Without it we would not have the quality of our new release of NetWare.”

Jonathan Richey
Director of Product Development
Novell

Adopt PVCS & PolyMake On Existing Projects

You can obtain the benefits of configuration management for your current project without disrupting development, regardless of how long your project has been under way. You can build PVCS archives from revisions stored in your present archives or simply adopt PVCS from the current date.

POLYTRON

High Quality Software Since 1982

The CASE Philosophy

*The whole picture involves integrating corporate plans,
systems design, and systems development into one system*

Michael Lucas Gibson

Computer-aided software engineering (CASE) represents a comprehensive philosophy for modeling businesses, their activities, and information-systems development. The CASE philosophy involves using the computer as a development tool to build models that describe the business, the business environment, and corporate planning, and to document computer-systems development from planning through implementation.

Components of CASE

Breaking CASE down into component parts makes it easier to understand. However, there is disagreement about whether upper CASE, middle CASE, and lower CASE have any reality. Many CASE vendors and gurus think that this functional separation is just a journalistic device. Perhaps it is, but it is also convenient and provides a familiar frame of reference for discussion.

With that in mind, I will use the terms here to refer to the computer-aided components supporting the various CASE functions. I make no claims about my definitions or even acceptance of these terms elsewhere. Upper CASE, often

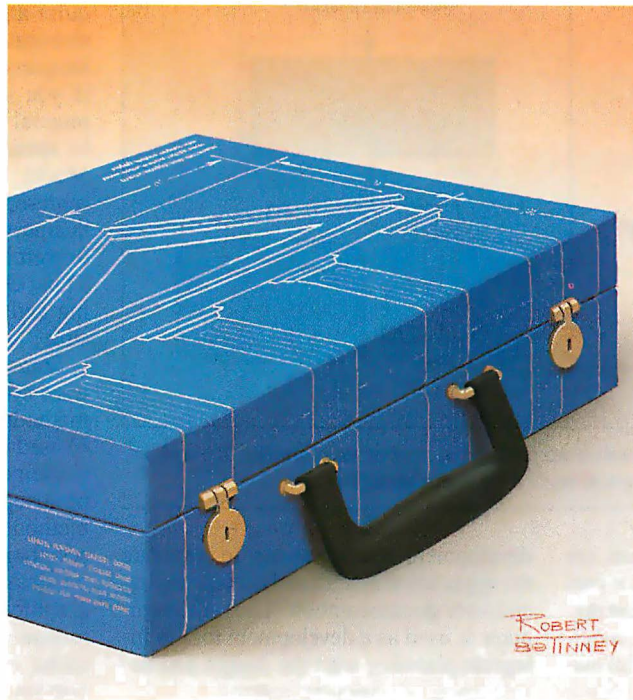

called computer-aided planning, will refer to a computer-aided component that supports corporate planning. Middle CASE will refer to a component that supports systems analysis and design. Lower CASE will refer to a component that supports systems development.

Another confusion in the CASE arena is that there are no standards. Each vendor includes and omits whatever it wishes

based on its own criteria. And each vendor would like its implementation to be accepted as the standard. Such organizations as the Software Engineering Institute at Carnegie-Mellon University and the Center for Advanced Information Management at Auburn University have emerged to provide CASE guidance. A research goal of the CAIM is to arrive at standards for CASE. (See the text box "The Center" on page 211.)

The complete picture of the CASE philosophy prescribes that specifications for corporate plans, systems design, and systems development become fully integrated. This occurs by sharing specifications for the three functions of corporate planning, systems analysis and design, and systems development across CASE components.

In a fully integrated CASE environment, computer systems originate in the corporate-planning function (see figure 1). Corporate planners create computer specifications for developing functional corporate plans using upper CASE, specifications that embody planning requirements for the company's fundamental activities.

continued

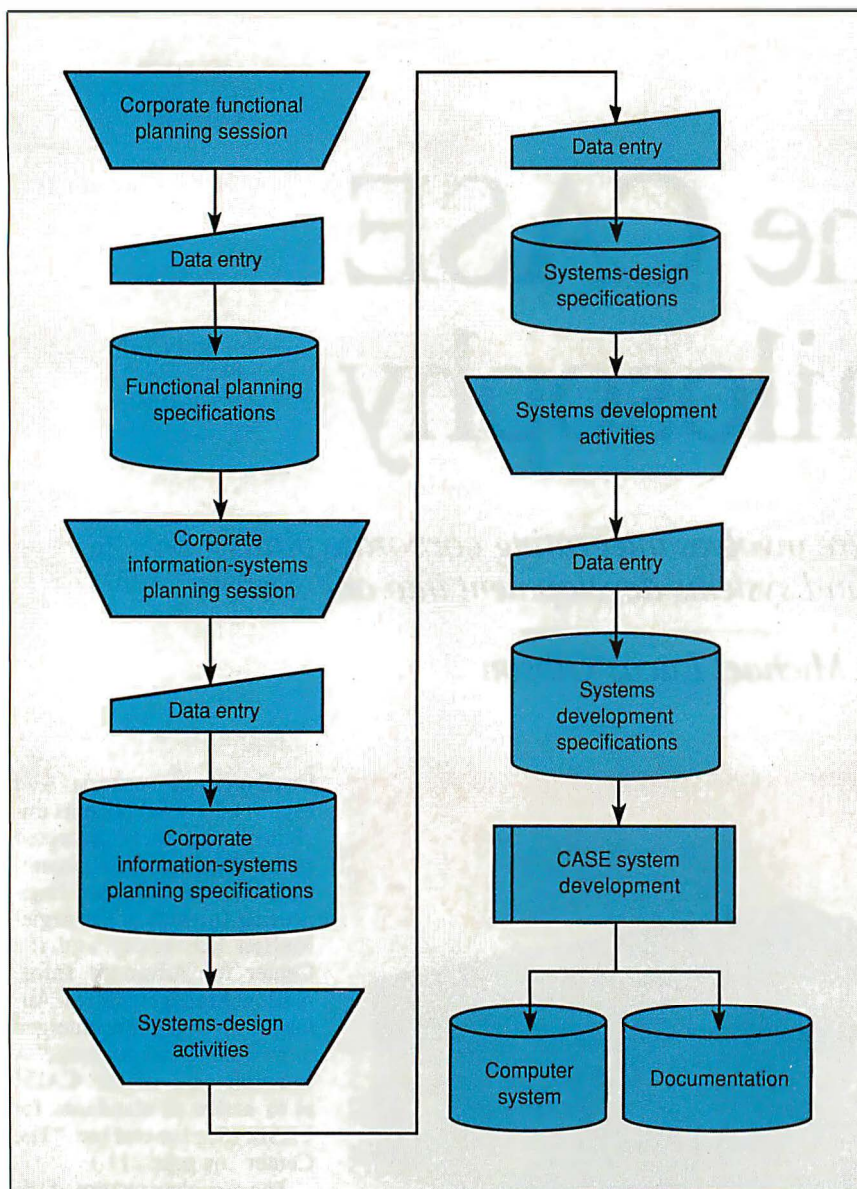

Figure 1: A fully integrated CASE environment: from corporate planning through systems analysis and design to program code and documentation.

These functional corporate plans are input to computer specifications for corporate information-systems planning. Corporate planners enhance these specifications relative to intrinsic information-systems attributes. Then the corporate-planning specifications are input to design specifications for computer systems. Systems analysts enhance these design specifications using middle CASE.

The design specifications are then input to the development specifications for computer systems and end-user documentation. Systems developers enhance the development specifications to make them more comprehensive using lower CASE. Lower CASE systems use these

development specifications to generate the application system and accompanying end-user documentation. Thus, the computer is used as a development tool to integrate planning with the design and development of computer systems.

Most of the understanding of how a business functions, and how information services that functioning, resides in the minds of a relatively small group. Over the years, companies have attempted to build models to document these things. These models were created to symbolize the knowledge of key people in an effort to better secure and more comprehensively use their accumulated knowledge.

A number of methodologies have been

devised for model building. These methodologies usually consist of a combination of diagramming techniques and text descriptions. Diagrams express pictorial images of the business's activities and of how it uses information to support these activities. Diagrams also graphically describe the attributes used in systems design and development.

The diagramming techniques use icons to represent various components of the business: personnel, resources, data, and so on. Each icon on representative diagrams usually has a text description explaining its purpose, its responsibilities relative to business activities and information support, its relationship to other icons on the diagrams, and so forth. The text descriptions include enough information to sufficiently describe the real-world object that the icons represent.

Model-building methodologies provide some guidance for building models that represent corporate activities and systems development. However, business models require frequent modifications as business changes. If the models are constructed by hand, these changes require a great deal of effort. As a result, elaborately constructed manual models frequently become outdated. In addition, if you spend a lot of effort building a manual model, you may not be inclined to spend additional effort to change it. Model building constructs a symbolic representation of various facets of the business for review and subsequent improvement prior to actual commitment. Thus, change is inherent in model building and should be made as easy as possible.

Some vendors have developed software systems that automate many of the methodologies (see references 1 through 6) used in model building. These systems implement a large portion of the CASE philosophy by providing diagramming methodologies accompanied by text descriptions. Many CASE systems execute on desktop computers with the more graphically oriented systems requiring a mouse. You issue commands through menu or function-key selection using a portion of the screen to enter appropriate model specifications.

Within the more graphical methodologies automated through CASE systems, some icons have a variety of purposes. The text description behind the icons describes what the icons symbolize within the facet of the business currently being modeled.

You enter the text descriptions into a portion of the CASE system known as the *dictionary* (some CASE systems have

embedded DBMSes serving this function). The dictionary contains preformatted screens associated with different graphical icons. Entries on these screens supply important information concerning the aspect of the business the icons symbolize. The dictionary also keeps a directory indicating the relationships between specific diagrams, icons, and text descriptions.

Upper CASE

Corporate managers spend much of their time trying to understand the company and create plans for its activities. Corporate plans prescribe goals, generate strategies for achieving these goals, establish policies to focus the company's operations toward these goals, and establish standards for acceptable levels of performance within these operations.

Upper CASE uses software to describe the company and its plans. It uses graphical diagrams to decompose the company's important aspects and describe them. Some of these aspects are the various departments and their functions and processes. Others include the goals, objectives, responsibilities, resources, problems, and so on, of the company and its various departments. Decomposing aspects of a business provides graphical and textual information to help you gain a clearer understanding of the company and the conditions facing it.

You can use these descriptions to create strategic plans. The planning specifications represent the resources and task completions needed to accomplish corporate plans. The planning methodology provides the structure into which you enter these planning attributes. The structure has built-in functionality for indicating the relationships between the components of the plan and the accoutrements they require. For different plans, the structure of the company and its requirements remains the same; only the planning-attribute values change.

Creating these models involves a great deal of clerical work. However, after you construct the business model and a number of planning models, you will find that you can reuse many dictionary specifications. For example, dictionary entries describing order-processing customers are reusable when you develop a market-survey planning model. The more you use upper CASE, the more reusable dictionary specifications you will have.

Every plan the company devises depends on timely information to ensure its success. Upper CASE systems contain planning specifications for functional

The Center

The Center for Advanced Information Management (CAIM) is a non-profit organization affiliated with Auburn University. Its purpose is to provide an organization to facilitate research in the field of information engineering. This body consists of approved members from both the academic and business communities.

Objectives

The general goal of the CAIM is to provide a forum for research activities related to information needs and methods for satisfying these needs. Research interests include facilitating enterprise modeling, organizational planning, executive information systems, systems analysis and design, systems development, system maintenance, and network configuration and management; standardizing documentation; facilitating reverse engineering, computer-integrated manufacturing, real-time system development, and information resource management; providing assistance for project management; integrating organizational planning, systems analysis and design, systems development, in-

formation resource management, and project management; managing computer software configuration; and facilitating estimate acquisitions.

The long-range plan for the center leads to establishing international standards for various aspects of information engineering. In addition, the CAIM will institute a certification program for several areas of information management as well as initiate the *Journal of Information Engineering*. The first activity will furnish badly needed standards in information management for everything from file formats for project specifications to standards for methodologies and procedures. The remaining two activities will provide a mechanism for industry and academic professionals to acquire recognition and proficiency in information engineering through personal experience and access to the literature.

The CAIM will work closely with the International Standards Organization (ISO) and the United States of America Standards Institute (USASI) to establish standards for all aspects of information engineering.

activities and for developing information systems.

Middle CASE

In middle CASE, you analyze problems with information and design solutions to them. Most middle CASE systems consist of diagramming and dictionary components operationally similar to those in upper CASE. However, the methodologies embodied in middle CASE are different. The combination of diagram and dictionary entries automates methodologies that systems analysts use. These systems also have special purposes for graphical icons and separate preformatted dictionary screens for describing how these icons symbolize real-world objects.

Manufacturers of middle CASE systems say that this software substantially reduces normal project-development life cycles. Another major benefit comes from storing the type of knowledge that usually resides only in the minds of systems analysts—their understanding of how the company functions and what its information needs are.

Very little information about how the company functions is directly related to the software that supports the company's

operations. This information involves describing what departmental operations are and why they are important; why operations are performed in a certain way, what information supports them, and how that information is used; why certain conditions influence operations, what information about these conditions is needed, and why; responsibilities for various operations; job functions of personnel, and how and why information serves these job functions; and so on.

Middle CASE systems provide the structure to store this type of information and make it more accessible. You can gain years of experience about the company's operations and how it uses information simply by "mousing around" in design specifications.

It is often said that only 25 percent to 30 percent of middle CASE specifications is transportable to lower CASE systems. Lower CASE systems create the actual development specifications for programs. Since middle CASE specifications predominantly involve documenting a company's activities and the ways in which information serves it, only a small percentage of these specifica-

continued

tions is directly mapped into lower CASE systems. Some people question the need for middle CASE systems, but the expert knowledge contained in the middle CASE specifications provides a common base of knowledge that is invaluable.

Creating analysis and design specifications also involves a lot of clerical work. But once a number of systems have been modeled using middle CASE systems, many design specifications will be reusable. And as you continue to use

middle CASE, reusable analysis and design specifications continue to multiply.

Lower CASE

Lower CASE uses a development software component to create a set of systems development specifications ultimately used to generate programs and in user documentation. The CASE development software system also contains a dictionary software system. However, it rarely provides a graphical component, since

physically oriented development specifications don't usually need it. Lower CASE systems specifications are usually directly related to programs within the developed system.

Traditionally, a dictionary system documents the characteristics of the real-world entities being modeled. Thus, its specifications usually only provide a comprehensive reference for the modeled phenomena. The CASE development dictionary, on the other hand, is an *active* dictionary, which lets you enter specifications that both describe and influence the development of the modeled object by providing criteria for its development as well as references to its attributes.

An active dictionary comprises three major components:

- a database of empty storage buckets in which to store the characteristics of the computing environment and explicit characteristics of the applications systems;
- frameworks for procedural logic and specific types of procedural commands and modules contained within typical programs in the applications systems; and
- an *activator* capable of combining environmental and application characteristics with selected procedural-command frameworks and modules to produce application programs.

The database of empty storage areas provides the location in which to store the characteristics of the computing environment. Thus, it is less essential to describe the computing environment during applications development. These characteristics are stored in the active dictionary's database during installation of the CASE development system. Subsequently, systems developers enter the characteristics of individual application systems into the active dictionary's remaining storage areas. These characteristics define the attributes of the system being developed.

The frameworks for 14 types of logical routines used in typical business systems are also embedded in the active dictionary. Regardless of program style or language, business programs contain either a single logical routine or a combination of logical routines from within this basic set. Five are batch-processing routines, and nine are on-line processing routines. All involve either information-reporting or data-updating functions. To generate programs, the activator com-

continued

the Telcor modem "simply ate up our data."

38.4K
bps



Our patented Model 2496 data compressing modem was the only 2400 bps unit included in this evaluation of 9600 bps dial modems. And it was judged the surprise of the lot!

Just imagine what our 9600 bps modem can do . . . dial data throughput up to 38,400 bps. What's more, the Telcor Model 2938 also talks to 300, 1200 and 2400 bps modems and fully supports MNP Levels 2-6.

The Telcor Model 2938 outperforms any other dial modem in the world. If

John H. Humphrey and Gary S. Smock
High Speed Modems
June 1988, Byte Magazine

you find that hard to believe, prove it to yourself. Order a pair at \$1195 apiece and try them for thirty days. High speed file transfer software for your PC-AT is included.

Call us toll free in the U.S. at 1-800-826-2938. Elsewhere call 1-508-653-3995. VISA and Mastercard accepted. Also available through local distributors.

telcor
TELCOR
SYSTEMS
CORPORATION

*the world's fastest
dial modems*

Would it hurt if you lost files on your hard disk without warning?

Would you like to make *sure* it never happens?

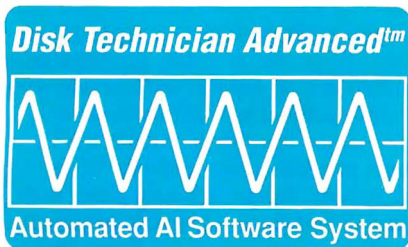

Now you can with *Disk Technician Advanced*: The world's only software that predicts, prevents and repairs the problems that cause costly file damage and loss. *Before* it happens.

PC MAGAZINE

"After witnessing a few minor miracles and a major miracle or two, I'm a believer."

Disk Technician Advanced finds and fixes all data-threatening conditions, recovers damaged or missing data, gets crashed systems up-and-running, even warns you when hardware is near failure! *Automatically.*

JOHN C. DVORAK

"If you're one of those souls who are plagued by hard disk problems, then take a look at *Disk Technician*..."

Disk Technician Advanced is fast and easy to use, too. There are no complex commands to learn.

Circle 325 on Reader Service Card (DEALERS: 326)

You'll never need to remove and reinstall files and programs. Installation is a snap. And *Disk Technician Advanced* takes less than 10 seconds of your time to run. You simply press the ENTER key once. Then *Disk Technician Advanced* does the rest, automatically. *Unattended.*

WASHINGTON POST

"The most sophisticated data protection for IBM PCs is Prime Solutions' *Disk Technician Advanced.*"



Why go through the pain of recovery routines? Disk Technician Advanced stops disasters before they happen ...

So get the world's only software that eliminates the fear of a disk crash. By preventing it from happening in the first place. Only \$189.95. Call now for the dealer nearest you, or to order direct.

800 847 5000 • 619 274 5000

PRIME SOLUTIONSsm
 We Make Technology Easy And Affordable™
 Prime Solutions Incorporated
 1940 Garnet Avenue • San Diego, CA 92109 USA

Disk Technician Advanced is designed to work on IBM PC, XT, AT, PS/2 and true clones using DOS 2.1 to 3.32. Not copy protected. All trademarks and servicemarks are acknowledged.

"Why do I need *Disk Technician Advanced* if...

...I backup every day?" A very wise practice. But when considering "hard disk disaster preparedness," think of backup as your "reconstruction" partner, and *Disk Technician Advanced* as your *prevention* partner. Backups cannot *prevent* file loss and damage. *Disk Technician Advanced* is the world's only software capable of this. Nor are your problems solved when you restore your files to the hard disk. You will most likely be putting good files into dangerous areas that will crash again. *Disk Technician Advanced* assures you that files are kept safe, because *Disk Technician Advanced* maintains the hard disk itself in perfect shape. Besides, who wants to waste time reloading and reinstalling files and programs when the problem could have been *prevented* in the first place? And what about all of the work you have lost forever since your *last* backup? *Prevention* is the key.

...I use Norton, Mace, PC Tools, SpinRite, OptTune, etc.?" All of these products, at best, may help you *after* a disaster has already occurred. Not a single one of them can find and fix all hard disk problems *before* disaster strikes. *Disk Technician Advanced* is the world's only software that can actually predict, repair and prevent file loss and damage *before* it happens.

...I optimize (defragment) my hard disk?" *Disk Technician Advanced* does not defragment your files. But if you use a defragmenter without *also* using *Disk Technician Advanced*, you will most likely be relocating good files into undetected bad spots and actually *cause* a crash. *Disk Technician Advanced* is the world's only software that can find and repair 100% of the bad spots. So you do not have to worry about losing or damaging files again.

...My hard disk is brand new (or, 'I've never had a problem with my hard disk.')" Every hard disk will lose data. Every hard disk will crash. It's not a question of 'if,' it is only a matter of 'when.' *Disk Technician Advanced* prevents file loss and damage from happening by repairing and maintaining your hard disk in perfect condition throughout its lifetime. And, eventually, when your hard disk is about to totally fail, *Disk Technician Advanced* is the world's only software that will warn you that it is about to happen, *before* you lose your valuable files, data and programs.

bines appropriate frameworks and the database of systems and applications characteristics.

Creating development specifications also involves a lot of clerical work. However, once some systems have been developed using lower CASE, many development specifications are reusable. As you continue to use lower CASE, reusable development specifications continue to multiply. Thus, the benefits attributed to lower CASE continue to expand.

Finally, the CASE development system can generate development and user documentation and make it available in various formats.

The Benefits of Using CASE

The benefits of upper CASE are more direct if you usually perform corporate planning. By using an upper CASE system to build an enterprise model, you gain greater insight into the importance of certain functions and how the activities they control affect the entire organization. You can better understand

1. corporate and departmental mechanisms and responsibilities;

2. the goals of the company and its departments;
3. the influence of operations on achieving these goals;
4. their place within corporate and departmental administration and operations;
5. the timeliness and sequence of operations;
6. factors influencing operations and goal achievement;
7. allocation of resources in support of operations;
8. the effect of external influences on the organization;
9. problems facing the organization; and
10. the importance of information relative to the success of the organization.

Using upper CASE systems to develop planning models gives you a clearer understanding of the company's direction and how you can contribute to its success. These planning models let you assess the impact of changing values for certain planning specifications on corporate plans. You can perform "what if"

analyses and assess worst-case and best-case scenarios. Thus, you can assess the impact of changing specifications prior to committing to these changes.

Models also provide the basis for project specifications. Many planning specifications can be mapped into project schedules, descriptions of activities and their time durations, and resource allocations, utilization, and costs. Vendors of upper CASE systems are trying to closely integrate their systems with commercially available project management software systems. They are trying to pass planning specifications entered into their systems to these project management systems. Thus, many initial activities performed during project management will be done without human intervention.

A major benefit of middle CASE is that it provides easier methods for changing systems design. It is also easier to determine that the analyst understands the problems and how to solve them. Design is inherently an iterative process:

- Users discuss their information needs with analysts;

continued

PERFORMANCE BREAKTHROUGH!

Teamwork[®], world's #1 workstation CASE environment, available for your PS/2.

If you have PS/2 workstations, you're ready to move into high gear with workstation CASE.

Only **Teamwork** for **OS/2** improves your productivity with:

- ▶ Easy to learn, easy to use, intuitive graphic user interface
- ▶ Multi-tasking, multiwindows; Support for work groups
- ▶ Complete syntactical checking and balancing; Project management
- ▶ Fully integrated analysis, data modeling and design environment for

only \$4,995.



PASSING
ZONE

CADRE Cadre Technologies Inc.
222 Richmond St.
Providence, RI 02903

Teamwork is a registered trademark of Cadre Technologies Inc.
PS/2 and OS/2 are trademarks of International Business Machines.

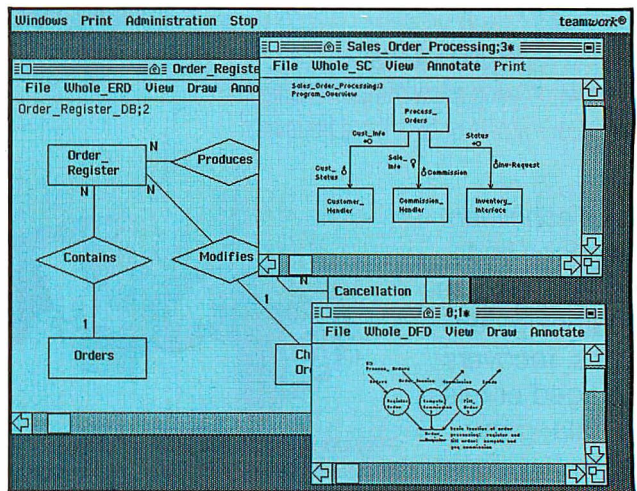

Just getting started with CASE? **Teamwork/PCSA** is a DOS-based Structured Analysis tool... compatible with Teamwork for OS/2... for **under \$1,000.**

Cadre gives you a fast start with hot-line support, maintenance services, excellent documentation, and numerous educational offerings. You'll even receive a money-back guarantee.

If you're using the PS/2, then you're ready for Teamwork. Anything else just won't meet your standards.

Call (401) 351-CASE

**NO
SPEED
LIMIT**

Our MAJOR ADVANTAGE - Supplying you with the Broadest Range of Software Ammunition.



ADVANTAGE SOFTWARE

LIST OURS	
BACKUP UTILITIES	
Copy II PC	40 35
Copy II PC Option Board	150 139
DS Backup +	80 72
Fastback Plus	189 109
Intelligent Backup	150 129
CAD	
AutoCAD	2895 CALL
Design CAD 3-D	299 165
Draft CAD Ultra	395 259
Draft 3D Modeler	295 199
Generic CADD	100 79
Generic CADD Level 3	200 149
Schema II	495 439
COMMUNICATIONS	
Carbon Copy +	195 120
Close Up - Customer	195 171
Close Up - Support	245 215
Crosstalk MK IV	245 159
Crosstalk XVI	195 99
Procomm PLUS	75 52
Relay Gold	250 164
Smartcom III	249 162
DATABASE	
Clipper	695 439
dBASE III +	695 395
dBASE IV	795 485
dBASE IV Dev. Edition	1295 899
FoxBASE +	395 335
Genifer	395 259
Paradox 3.0	725 543
PC/Focus	1295 989
R & R	149 119
R:Base for DOS	725 489
Tom Rettig's Library	80 75
DESKTOP ANIMATION	
GRASP 3.1	149 129
PC Emcee	995 789
Showpartner FX	350 279
DESKTOP PUBLISHING	
Adobe Illustrator 88 (MAC)	495 359
ByLine	295 185
GEM/3 Desktop Publisher	299 189
Pagemaker	595 429
PFS: First Publisher	129 79
Ventura Desktop Publisher	899 590
DISK MANAGEMENT	
Flash	70 49
Mace Gold	149 129
Mace Utilities	99 85
PC Tools Deluxe	79 69
V Cache	60 55
Xtree	70 60
XtreePro	129 111
INFORMATION MANAGERS	
Agenda	395 291
askSam	295 209
DayFlo Tracker	100 90
Gofer	80 69
GrandView	295 179
Notebook II	189 161
Tornado w/ Libraries	150 109
ZIndex Professional	295 159
LANGUAGES	
APL PLUS	695 476
C.talk	150 135
Lahey FORTRAN F77L	477 453
Lattice C	450 279
Microsoft C	450 299
NDP Fortran or C-386	595 529
Phar Lap 386 i ASM/LINK	495 399
Turbo C	150 112
Turbo C Professional	250 187
Turbo Pascal	150 112
Turbo Pascal Professional	250 187
Zortech C +	150 129
LANGUAGE UTILITIES	
Brief	195 CALL
db.File	395 322
db.Retrieve	395 322
Flowcharting II Plus	229 207
HALO '88	325 229
Interactive Easyflow	150 135
Matrix Layout	150 101
Periscope I	795 675
Periscope III	1395 1255
Vermont Views	395 CALL
Vq	270 CALL
LOTUS ADD-ONS	
4Views	150 119
4Word	100 79
@BASE	195 121
Allways	150 117

LIST OURS	
At Liberty	295 199
Graph-in-the-Box	140 109
Inword	100 80
Look & Link	100 64
Note-It Plus	80 68
Noteworthy	80 59
R & R (Lotus Version)	149 119
See More	80 65
Sideways	70 45
Smartnotes	80 69
Spellint	80 65
Sqz! Plus	100 CALL
PRESENTATION GRAPHICS	
Concorde	695 509
Diagraph	395 242
Draw Applause	495 309
Freelance Plus	495 322
GEM Graph Present. Pack	495 309
GRAPH Plus	395 CALL
Graph-in-the-Box	140 109
Harvard Graphics	495 313
Microsoft Chart	395 265
PIXIE	195 185
Xerox Presents	495 325
PROJECT MANAGEMENT	
Harvard Total Project II	595 515
Micro Planner	595 419
Project 4.0	495 340
Super Project Plus	395 267
Time Line 3.0	595 345
SCIENCE AND ENGINEERING	
Asystant Plus	895 849
DADISP	795 719
Eureka: The Solver	167 119
Gauss Math + Stat Package	395 359
HiWire-Plus	895 805
Labtech Notebook	995 799
MathCAD	349 279
Micro-Cap III	1495 1269
smARTWORK	895 805
T3 Scientific Word Processor	595 499
Tango PCB Series II	595 559
TECH GRAPH PAD v.3.0	395 379
TK Solver Plus	395 349
SPREADSHEET	
LOTUS 1-2-3	495 289
Lucid 3-D	149 139
Multipan	195 129
PC-Excel	495 299
Quattro	248 185
Silk	298 CALL
Supercalc V	495 349
20/20	500 CALL
STATISTICS	
CSS	495 459
Microstat II	395 349
NWA Statpak	399 359
SPSS/PC	795 749
STATGRAPHICS	895 675
Systat	595 549
Systat/Sygraph	795 709

LIST OURS	
386 OPERATING SYSTEMS/CONTROL PROGRAMS	
Concurrent DOS 386 (3 User)	395 335
DESQview 386 w/QEMM	190 169
Microsoft Windows/386	195 130
SCO Sys. V 386 (Complete)	1495 1195
VM/386	245 209
WORD PROCESSING	
Displaywrite IV	495 425
Manuscript	495 322
Multimate Advantage II	565 271
PC-Write 3.0	89 69
Q & A Write	349 207
Samna Word IV	595 343
Volkswriter V3	295 170
PRIMARY TARGET	
MICROSOFT WORD 5.0	
Word 5.0 has new features that solve the toughest word processing problems, yet it offers unprecedented ease of use. The interface has been streamlined, and all formatting options are now shown on screen, offering better flexibility and control when editing and printing.	
New 5.0 productivity tools include macros, to automate long sequences of commands; Print Preview, to see how documents will look before they are printed; easier ways to integrate data, text and graphics; a new Show Layout option for editing columns on screen; a greatly expanded Help index and much more.	
List: \$450	Ours: \$240
LIST OURS	
Word 5.0	450 240
Word Perfect v. 5.0	495 228
Wordstar Pro v. 5.0	495 290
ASHTON TATE	
ByLine	295 185
ChartMaster	375 205
ChartMaster Premium Pack	395 225
dBASE III +	695 385
dBASE IV	795 485
dBASE IV Developer's Edition	1295 899
dBASE Moc	495 325
Diagram Master	345 190
Diagram Master Prem. Pack	365 206
Draw Applause	495 309
Framework III	695 405
Front Runner	195 121
Full Paint	100 65
Full Write Professional	395 236
LIST OURS	
MS Pascal	300 199
MS Project 4.0	495 340
MS QuickBASIC	99 69
MS QuickC	99 69
MS Sort	195 130
MS Windows	99 69
MS Windows/386	195 130
MS Windows Development Kit	500 319
MS Word 5.0	450 240
MS Works	149 99
PETER NORTON PUBLISHING	
Norton Commander	89 55
Norton Editor	75 50
Norton Guides:OS/2	150 109
Norton Guides:Specify Lang.	100 75
Norton Utilities	100 59
Advanced Version	150 99

LIST OURS	
Map Master v. 6.01	395 240
Multimate Adv. II	565 271
Rapid File	295 195
Sign Master	245 139
BORLAND	
Eureka: The Solver	167 126
Paradox 3.0	725 543
Paradox 386	895 671
Quattro	248 185
SideKick Plus	200 149
Sprint	199 149
Superkey	100 75
Turbo Assembler/Debugger	150 112
Turbo Basic	100 75
Turbo C 2.0	150 112
Turbo C 2.0 Professional	250 187
Turbo Pascal 5.0	150 112
Turbo Pascal 5.0 Professional	250 187
Turbo Prolog	150 112
LOTUS DEVELOPMENT	
Agenda	395 299
Freelance + Graphwriter II	495 322
Hal	150 89
Lotus 1-2-3	495 289
Lotus Metro	85 59
1-2-3 Report Writer	95 69
Manuscript	495 325
Signal	595 553
Symphony	695 422
MICROSOFT	
MS BASIC/6.0	295 199
MS C	450 299
MS COBOL	900 599
MS Excel	495 299
MS FORTRAN	450 299
MS Learning DOS	50 40
MS Mach 2.0	495 329
MS Macro Assembler	150 99
MS Mouse Bus or Serial w/ Paintbrush & Mouse	150 99
Menus	150 99
w/ EasyCAD	175 119
w/ Paintbrush & Windows	200 139
MS Multiplan	195 129
MS OS/2 Programmer's Toolkit	350 229

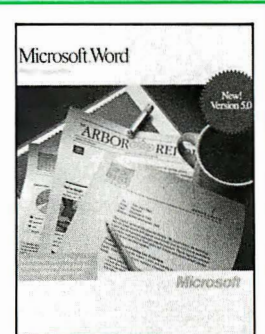

Microsoft®

Terms & Policies

All prices subject to change without notice. We accept Visa, MC, AMEX (2% surcharge on AMEX). Shipping \$4 per item sent UPS Ground. Allow 14 days for personal/company check clearance. Returns subject to 15% restocking fee. RA # required. PO's welcome from Fortune 1000 and other qualified organizations.



ADVANTAGE SOFTWARE

A Division of Voyager Software Corp.

In the U.S. call:
1-800-333-3141
 N.Y. / International **914-332-0756**
 Fax: **914-332-4021**

55 South Broadway, Suite B, Tarrytown, NY 10591

Circle 16 on Reader Service Card

Power, Speed, Performance

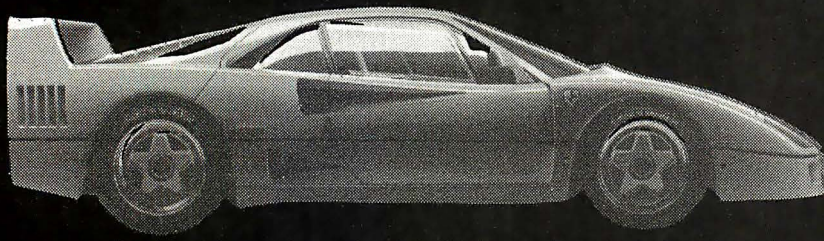

Any Questions?

803086 Intel processor running at 20 MHz

1 mb 32 bit RAM upgradable to 8 M.B. on motherboard
Socket for 80387 math coprocessor

One 32-bit expansion slot
1.2 M.B. floppy disk drive
1.44 M.B. floppy disk drive
80 M.B. Seagate Hard disk (28 m.s.)

14" Monitor flat with adapter

13 month parts & labor warranty

30 day Money Back Guarantee

Options: For each additional Meg of RAM \$440

EGA Option + \$350

VGA Option + \$460

25 Mhz option + \$400

Tower Chassis + \$200

Hard Disk option up to 2 Giga byte

■ Above system 80286-20 minus \$500

Call Today for Custom Configurations

386

\$2699

Specials

80286-12, 512K, 1.2F, FHDC, 200 watt P/S
101 KB, S/P, P/P..... **\$749.00**

80286-20, 2mb, 1.2F, FHDC, 200 watt P/S
101 KB, S/P, P/P..... **\$1,299.00**

Gas Plasma Portable 286-12,
640K, 1.2 FDD, 20MB H.D. S/P, P/P..... **\$1,999.00**

MICRO TELESIS

Uncompromised Quality and Service

(714) 557-2003 Fax: (714) 557-9729

1260A Logan Ave., Ste. A2
Costa Mesa, CA 92626

- analysts use diagrams and dictionary entries to document them;
- users review these diagrams and dictionary entries and suggest modifications to them; and
- analysts respond to these suggestions by making appropriate changes to analysis and design specifications.

The last two steps continue until the analysis and design specifications more correctly correspond to what is needed.

A second benefit of middle CASE is that it facilitates joint applications-design sessions. In these sessions, systems professionals and end users rapidly interact and document the requirements for application systems. These sessions usually occur at the beginning of development projects and provide a jump start for the projects. As the interaction continues, its results are recorded in diagrams and preliminary dictionary entries. Thus, end users can directly and quickly influence analysis and design.

A third major benefit involves the prototyping facility that most middle CASE systems provide (see reference 7). This facility allows analysts to create screens to simulate the I/O screens and reports to be used as the end-user interface. These prototype screens are produced early in the analysis and design part of the project. You can use them to simulate data access and update functions. Prototyping lets you see how the completed system will service your information needs.

Lower CASE systems generate 60 percent to 80 percent of the program code in the system. As a result, the major benefit of lower CASE is the substantial reduction in the time required to actually develop the system. When lower CASE systems are used, the majority of time spent in systems development involves writing the customized code required for specialized processing.

A second major benefit concerns the ease of modifying systems generated by lower CASE systems. Since lower CASE systems generate the majority of code, maintenance activities usually only involve modifying any custom code. As a result, maintenance activities are less complicated and require less time, so requests for system modifications can be completed more rapidly. In addition, maintenance activities are performed through the active dictionary, which maintains a directory of the application programs and modules. Thus, the dictionary

continued

LepreCard Disk Cards for PC & AT Computers

Shamrock's LepreCards feature the latest low power, high reliability disk drives and controllers. You can use them as the first or second hard disk in your system. Low power consumption means less strain on your system. You get a 1 year warranty, unlimited technical support, & our illustrated installation and user's guide. Models available for IBM PC/XT and compatibles, AT's and compatibles, as well as the TANDY 1000/A/SX/TX/TL/SL.

FREE SOFTWARE including **TakeTwo**, the backup utility PC MAGAZINE named Editors choice in 1986 & 1987, & LepreCache disk cacheing from Multisoft.



CAPACITY	20MB	32MB	49MB	65MB
AVG. ACCESS	40ms	40ms	28ms*	16ms*
8 Bit PC/XT	\$299	\$319	\$549	\$649
16 Bit PC/AT	N/A	\$379	\$599	\$679

*Average access speed per partition. Tandy 1000/A/SX/TX/ LepreCards add \$20.

TakeTwo

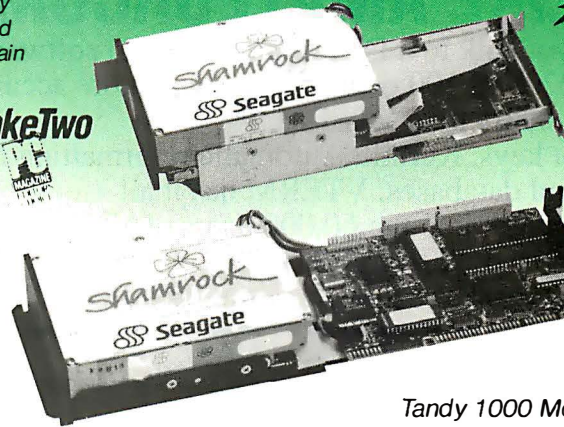

**NOW
for AT**



Tandy 1000 Model

Seagate PC/XT Disk Kits

- Pretested & formatted
- Western Digital short slot controller
- 30 page installation guide & reference manual
- Cables, mounting screws, full & half-height face plates
- **FREE!** **TakeTwo** high speed backup software, PC MAGAZINE "Editors Choice"
- **FREE!** **LepreCache** software by Multisoft
- 1 year Warranty, 30 Day Money Back Guarantee
- Optional: 150 Watt, UL/FCC approved power supply for IBM PC's \$69

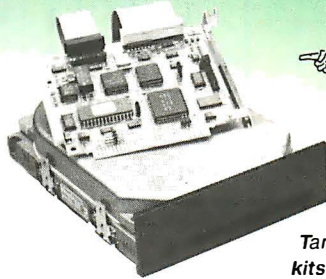

Tandy 1000 kits add \$20

30MB KIT \$299

- Seagate ST238 - 32.7MB/65ms/Half-Height/14.8 watts

65MB KIT \$499

- Seagate ST277R - 65.5MB/28ms/Half-Height/11 watts

Seagate

Matched Pair Kits

20MB \$249
40MB \$349

- Seagate Drive & Matched Controller
- 1 year factory warranty
- 15% faster throughput than ST251 drive

NEW

NEW

LepreKeys

\$99

- 111 Key enhanced layout
- Built-in Solar Powered Calculator
- Switchable Ctrl, Capslock keys
- Double injection molded key caps
- Removable function key template
- ALPS tactile keyswitches as used by Northgate
- 100% PC/XT/AT/386 & Novell network compatible



AT Disks

- Seagate Drive with IBM AT rails & cables
- **FREE!** **OnTrack** large drive software
- **FREE!** **LepreCache & TakeTwo** backup software
- Formatted, Partitioned & Tested

Size	Model	Speed	Format	Capacity	Price
HH	ST251	40ms	MFM	48MB	\$359
HH	ST251-1	30ms	MFM	42MB	\$449
HH	ST277R	40ms	RLL	65MB	\$449
FH	ST4096	28ms	MFM	80MB	\$599

286/386 Computers

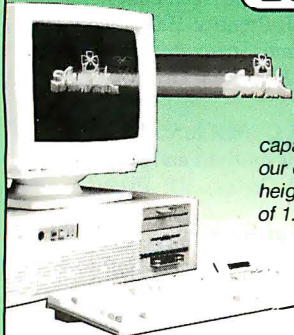

SHAMROCK Computers give you the maximum in performance and value.

Our data crushing systems come standard with high performance SCSI disk interfaces. This gives you the data transfer capabilities required by this high performance generation of systems. All our computers have 8 slot motherboards, room for 1 full and 3 half-height drives, serial/printer ports, AWARD BIOS, clock/calendar, choice of 1.2 MB or 1.44 MB floppy drive, and LepreKeys Enhanced Keyboard with tactile switches and built-in solar calculator. Our 286 systems feature 12 & 16 MHz processors and 512K RAM standard, upgradable to 4 MB on system board.

Our 386 systems offer 16 & 20 MHz processors and 1 MB RAM standard, upgradable to 8 MB. A 64K static column RAM cache operating at 35 nanoseconds insure maximum processor performance.

And don't forget that when you buy from Shamrock you get a 1 year warranty and 30 day money back guarantee.

286 COMPUTERS			
SYSTEM	NORTON MIPS	PRICE	SI V4.0
IBM Model 50Z	11.2	1.6	\$2,995
Shamrock 286-12/1 wait	11.8	1.9	\$ 799
Shamrock 286-12/0 wait	15.3	2.5	\$ 888
Shamrock 286-16/1 wait	15.9	2.6	\$ 899

386 COMPUTERS			
SYSTEM	NORTON MIPS	PRICE	SI V4.0
Compaq 386-16	15.6	2.8	\$3,995
Shamrock 386-16/0 wait	18.7	2.8	\$1,799
Shamrock 386-20/0 wait	24.4	4.3	\$1,999

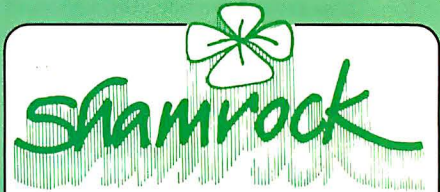

733-AA Lakefield Rd., Dept. B,
Westlake Village, CA 91361

to order or get our free catalog, call
TOLL FREE
800-722-AT-XT



MMC California
(805) 373-7847
FAX
(805) 379-9345

- No extra for Visa/Master/Discover (AMEX add 3%).
- Prices include UPS surface shipping.
- Federal Express shipping just \$1.50 per pound.
- 30 Day money back guarantee.
- Corporate & Institutional P.O.'s accepted.
- Call for our **FREE CATALOG**.

“IT MAKES PROCOMM LOOK LIKE AMATEURCOM.”

If you talk to a DEC mainframe, no software emulates the VT220, VT100 or VT52 terminal more accurately or professionally than VTERM.*

Hot keys. Kermit. Automatic reformatting for spreadsheets and databases. VTERM has it all.

Why not join the 60,000 users of VTERM (many of whom moved up from Procomm). And try the DEC terminal emulation package that's in a totally different league.

FREE EVALUATION KIT.

Yes, send me a free time-limited, full-blown working copy of VTERM/220, which is mine to keep.

Name _____

Title _____

Company _____

Address _____

Telephone (____) _____

I am a user dealer . Mail to:

Coefficient Systems Corporation

611 Broadway, New York, New York 10012 (212) 777-6707 BYP-4/89

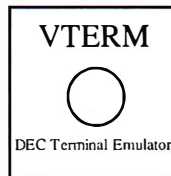

* VTERM refers to VTERM/220, VTERM/4010, etc. products from Coefficient Systems Corporation. Procomm is a trademark of Datastorm Technologies, Inc.

Questions? Want faster action? Call (212) 777-6707, ext. 404.

nary provides major assistance during maintenance activities.

A final major benefit involves lower CASE prototyping capabilities. Prototypes produced by most middle CASE systems require you to be logged onto the middle CASE system for prototype execution. As a result, prototype execution usually requires familiarity with the middle CASE system. Lower CASE systems produce prototypes that function like stand-alone systems, so you don't need specialized training to use them.

An Exciting Promise

CASE benefits you in many ways. You accrue benefits from each component of the CASE philosophy. The models created using CASE systems enable you to better understand your company and the conditions facing it. You can evaluate situations more judiciously and make more insightful decisions leading to better company performance. You can view the intent of systems design and influence its progress. And completed systems will be consistent with current organizational and departmental planning.

The promise of the CASE philosophy is an exciting one. As CASE continues to evolve, it will provide the framework needed for more timely and tightly integrated corporate planning and systems development. ■

REFERENCES

1. DeMarco, T. *Structured Analysis and System Specification*. New York: Yourdon Press, 1978.
2. Dolin, K. *Business Computer Systems Design*. Santa Cruz, CA: Mitchell Publishing, 1984.
3. Gane, C., and T. Sarson. *Structured Systems Analysis: Tools and Techniques*. Englewood Cliffs, NJ: Prentice-Hall, 1979.
4. Hansen, K. *Data Structured Program Design*. Topeka, KS: Ken Orr & Associates, 1984.
5. Martin, J., and C. McClure. *Diagramming Techniques for Analysts and Programmers*. Englewood Cliffs, NJ: Prentice-Hall, 1985.
6. Wallace, S. "Methodology: CASE's Critical Cornerstone." *Business Software Review*, April 1988.
7. Boar, B. H. *Application Prototyping: A Requirements Definition Strategy for the 80s*. New York: John Wiley & Sons, 1984.

Michael Lucas Gibson, Ph.D., is an associate professor of management at Auburn University in Auburn, Alabama, and one of the founders of the Center for Advanced Information Management. He can be reached on BIX c/o "editors."

People are talking about us.

When professional FORTRAN programmers develop or port large programs they use Lahey's F77L-EM/32 and F77L-EM/16, *PC Magazine's 1988 Technical Excellence Award Winners*. F77L-EM/32 is a fast 32-bit protected-mode compiler that accesses up to 4 gigabytes of memory on 80386s. F77L-EM/16 gives 80286 users the power to create 15 megabyte programs. These protected-mode FORTRANS include the features that have made them, and our F77L and Lahey Personal FORTRAN, market leaders: full ANSI 77 Standard, VAX and IBM VS extensions, fast compilation, comprehensive diagnostics, and a powerful debugger.



When people talk about FORTRAN the name mentioned most often is



Contact us to discuss our products and your needs. (800) 548-4778
Lahey Computer Systems, Inc. P.O. Box 6091, Incline Village, NV 89450
Tel: (702) 831-2500 FAX: (702) 831-8123 Tlx: 9102401256

ESTABLISHED
1968

MONTGOMERY GRANT

BYTE
4/89

OUTSIDE USACALL
(718)692-0071

For Customer Service
Call Mon-Fri: 9:30am-4:30pm
(718) 692-1148

Retail Outlet: Penn Station, Main Concourse
(Beneath Madison Square Garden) New York City, NY, 10001
Store Hours: Mon-Thurs, 8:30am-8pm/ Fri, 8:30am-5:30pm/ Sat, CLOSED /Sun, 9:30am-7
FOR ORDERS & INFORMATION CALL TOLL FREE

1-800-759-6565

OR WRITE TO:
Montgomery-Grant Mail Order
Department, P.O. Box 58,
Brooklyn, N.Y., 11230

FAX NO. 7186923372
TELE 422-132 MGRANT

ORDER HOURS: Monday-Thursday, 9:00am-7:00pm/Friday, 9:00am-6:30pm/Saturday CLOSED/ Sunday, 9:30am-6:00pm
NO SURCHARGE FOR CREDIT CARD ORDERS / WE INVITE CORPORATE AND EDUCATIONAL CUSTOMERS
CORPORATE LEASING AVAILABLE / DISCOUNTS FOR QUANTITY ORDERS

LAPTOPS



**AMSTRAD
PPC-640 SD**
•640K
•720K Floppy Drive
•Built-in 2400 Baud Modem
\$769

AMSTRAD PPC-640 With Two Drives.....	\$849
TOSHIBA 1600.....	\$3269
TOSHIBA 3100 e.....	\$2799
NEC MULTISPEED EL II.....	\$1499
NEC MULTISPEED HD.....	\$2149
TOSHIBA 1000.....	\$749
TOSHIBA 1200H.....	\$2199
TOSHIBA 1200 HB.....	\$2399
TOSHIBA 3200.....	\$3669
TOSHIBA 5100.....	\$4599
ZENITH 184 w/TWO FLOPPIES.....	\$1469
ZENITH 184-2 w/20MB.....	\$2199
ZENITH 184-98 w/20MB MODEM.....	\$2099
ZENITH 286 w/20MB.....	\$3299
ZENITH 286 w/40MB.....	\$3569
SPARK EL.....	\$999
QUADRAM J.T. FAX FOR LAPTOPS.....	\$259

MODEMS, EXTERNAL DRIVES & ACCESSORIES
AVAILABLE FOR ALL LAPTOPS



**EPSON
EQUITY 1+**
IBM XT COMPAT. PKG.
• 640K RAM w/Clock Calendar
• 360K Drive
• Keyboard
• Serial and Parallel Ports
• 12" High Resolution Monitor
• MS DOS / GW Basic
\$799

SAME W/20MB HARD DRIVE.....\$1059
SAME W/30MB HARD DRIVE.....\$1099
SAME W/40MB HARD DRIVE.....\$1199
SAME W/TWO 360K FLOPPIES.....\$679



EPSON EQUITY II+
IBM AT COMPATIBLE
HARD DRIVE PACKAGE
• Keyboard
• 640K RAM
• 80286 Microprocessor
• 1.2MB Floppy Drive
• 20MB Hard Drive
• 12" Monitor
• MS DOS/GW Basic
\$1499

SAME W/30MB HARD DRIVE.....\$1549
SAME W/40MB HARD DRIVE.....\$1649
LOGITECH MOUSE M-7.....\$59.95



EPSON EQUITY III+
IBM AT COMPATIBLE
20MB HARD DRIVE PKG.
• Keyboard
• 80286 Processor
• 640K RAM
• 68712 MHz
• 1.2 MB Floppy Drive
• 20MB Hard Drive
• 12" Monitor
• 8 Expansion Slots
• Serial & Parallel Ports
• MS DOS/GW Basic
\$1799

SAME W/30MB HARD DRIVE.....\$1849
SAME W/40MB HARD DRIVE.....\$1949

WE RECONFIGURE ANY OF OUR COMPUTER PKGS. TO FIT YOUR SPECIFICATIONS.
CALL FOR INFORMATION. WE CARRY MODEMS, DRIVES, CARDS COLOR MONITORS
& ALL OTHER ACCESSORIES FOR YOUR COMPUTER

LEADING EDGE

MODEL D3

• Keyboard
• 2MB RAM
• 1.2MB Floppy Drive
• 65MB Hard Drive
• 16MHz
• 12" VGA Monitor
with VGA Card
• MS DOS/OS2
\$3699

MODEL D2.....CALL

MODEL D

IBM XT COMPATIBLE PKG.
• 512K RAM/Computer
• Keyboard
• 360K Floppy Drive
• 4.77-7.16 MHz.
\$699

SAME W/TWO 360K FLOPPIES.....\$769
SAME W/20MB HARD DRIVE.....\$949
SAME W/30MB HARD DRIVE.....\$999

COMPAQ 286 MODEL 1

IBM AT COMPAT. PKG.
640K • 1.2MB • Floppy Drive
7 Expansion Slots • 8/12 MHz.
12" Monitor • MS DOS/GW
Basic
\$1799

Commodore PC10-1

IBM XT COMPAT. PKG.
• 512K RAM
• 360K Floppy Drive
• 12" Monitor
• Serial & Parallel Ports
• Keyboard
• Box of 10 Diskettes
\$499

IBM XT

HARD DRIVE PKG.

• IBM XT Computer
• IBM Keyboard
• 256K RAM
• Expandable to 640K
• 360K Disk Drive
• 20MB Hard Drive
• Pkg. of 10 Diskettes
(Monitor Optional)
\$1129

IBM XT PACKAGE WITH TWO FLOPPY DRIVES.....

\$899

IBM AT

HARD DRIVE PKG

• 1.2MB Floppy Drive
• 20MB Hard Drive
• Serial/Parallel Ports
• Keyboard
(Monitor Optional)
\$1699

IBM AT w/2 FLOPPIES.....\$1499



PACKAGES

APPLE IIC+ w/Floppy
Drive & 12" Monitor
\$599

APPLE IIEw/5.25 Disk
Drive and 12" Monitor
\$749

APPLE IIGS COMPUTER PACKAGE

• Apple IIGS Computer
• 512K Upgrade
• RGB Color Monitor
• Apple 3.5" Disk Drive
\$1499

IMAGEWRITER II PRINTER.....\$449
MAC SE COMPUTER DUAL/DISK DRIVE.....\$2299
MAC SE COMPUTER W/20MB
APPLE HARD DRIVE.....\$2749
APPLE MAC II.....\$3499
APPLE MAC II W/40MB.....\$4299

AMIGA

NEW

AMIGA 500 w/Built-in 5.25" Drive	\$519
AMIGA 500 w/1084S Monitor	\$799
AMIGA 2000 w/Built-in 3.5" Drive	\$1399
AMIGA 2500	\$3199
AMIGA 2000 H.D.	\$1999
AMIGA 1084S RGB MONITOR.....	\$294.95
AMIGA 1010 DISK DRIVE.....	\$189.95

ALL AMIGA PERIPHERALS AND
ACCESSORIES IN STOCK!!

PRINTERS

STAR NX-1000.....	\$169.95	EPSON FX-1050.....	\$489.95
NX-1000		FX-850.....	\$339.95
RAINBOW.....	\$219.95	LQ-500.....	\$315.95
NX-2400.....	\$299.95	LQ-850.....	\$529.95
CITIZEN		LQ-950.....	\$589.95
MSP-15E.....	\$329.95	LQ-1050.....	\$729.95
MSP-40.....	\$289.95	LQ-2550.....	\$919.95
MSP-45.....	\$369.95	LX-800.....	\$189.95
MSP-50.....	\$349.95	TOSHIBA	
Tribute-124.....	\$389.95	321-SL.....	\$449.95
Tribute-224.....	\$589.95	NEC	
NEC		P2200.....	\$349.95
P2200.....	\$349.95	P5200.....	\$499.95
P5200.....	\$499.95	P5300.....	\$669.95
P5300.....	\$669.95	OKIDATA	
OKIDATA		OKI-120.....	\$189.95
OKI-120.....	\$189.95	OKIMATE 20.....	\$119.95
OKIMATE 20.....	\$119.95	OKIDATA 180.....	\$239.95
OKIDATA 180.....	\$239.95	DICOMIX 150 PRINTER FOR LAPTOPS.....	\$298.95
DICOMIX 150 PRINTER FOR LAPTOPS.....	\$298.95	SPECIALI KXP-4450.....	\$1499

HP LASERJET SERIES II
\$1629

1 MB EXPANDER.....	\$349
2MB EXPANDER FOR LASERJET II.....	\$749
HP DESKJET PRINTER.....	\$689
HP LASERJET IID.....	\$2895

SHARP PC-7100A PORTABLE

IBM XT COMPATIBLE COMPUTER PKG.

• Detachable Keyboard
• Backlit Screen
• 8 MHz, Turbospeed
• 5.25" Floppy Drive
• 20MB Hard Drive
• Serial/Parallel Ports
\$1288

PC 7000A2
w/2 Floppies.....\$788

AMSTRAD PC-1640

IBM XT COMPATIBLE COMPUTER PKG.

• Keyboard
• 640K RAM Turbospeed
• Two 360K Drives
• 12" Monitor
• FREE Mouse & Software
• MS DOS/GW Basic
\$729

W/ONE FLOPPY AND 20MB.....\$1029
EGA AND CGA MODELS IN STOCK!!

COMMODORE COLT

IBM XT COMPATIBLE PACKAGE

• Keyboard
• Two 360K Floppies
• Serial & Parallel Ports
• 12" Monitor
• MS DOS/GW Basic
\$669

PC 7000A2
w/2 Floppies.....\$788

SANYO

PR-3000A

DAISY WHEEL LETTER
QUALITY PRINTER
\$59.95 SPECIAL
PURCHASE

AST

MODEL 80

HARD DRIVE PKG.
• 80286 Processor
• Keyboard
• 1.2MB Floppy Drive
• 20MB Hard Drive
• 12" Monitor
• MS DOS/GW Basic
\$1599

SAME PACKAGE W/30MB.....\$1649
SAME PACKAGE W/40MB.....\$1749

NEC

POWERMATE 1

HARD DRIVE PKG.
• 640K
• Keyboard
• 10 MHz
• 1.2MB Floppy Drive
• 20MB Hard Drive
• Serial/Parallel Ports
• 12" Monitor
• 80286 Processor
\$1599

**SEAGATE 20, 30, 40, 60,
80MB HARD DRIVES IN
STOCK!**

MAGNAVOX EGA Monitor.....\$339
MAGNAVOX EGA Monitor w/EGA Card.....\$459
MAGNAVOX VGA Monitor.....\$369
MAGNAVOX VGA Monitor w/VGA Card.....\$569
NEC MULTISYNC II.....\$579

VENDEX HEADSTART III

• 8-12 MHz
• 1MB RAM
• 5.25" 1.2MB Floppy
• 3.5" 1.44MB Floppy
• 30MB Hard Drive
• VGA/EGA/CGA/MDA
Included
• Parallel/Serial Ports
• Mouse
• MS DOS
• 12" VGA Monitor
\$2599 \$7000
SOFTWARE
INCLUDED

PERSONAL SYSTEM 2

PS/II MODEL 30.....	\$1299
PS/II MODEL 30 w/20MB.....	\$1699
PS/II MODEL 30/286-002.....	\$1549
PS/II MODEL 30/286-021.....	\$1999
PS/II MODEL 50 w/20MB.....	\$2499
PS/II MODEL 50Z w/30MB.....	\$2849
PS/II MODEL 50-061.....	\$3249
PS/II MODEL 60-041.....	\$3299
PS/II MODEL 60-071.....	\$3619
PS/II MODEL 70-E61.....	\$4199
PS/II MODEL 80-041.....	\$4295
PS/II MODEL 80-071.....	\$4799
5.25" 360K External Drive for IBM PS/II-30 +PS/11-50.....	\$129
PACIFIC RIM 5.25" 1.2MB External Drive for IBM PS/II 50/60/70/80.....	\$259

IBM PERSONAL SYSTEM I MONITORS
8503 MONOCHROME.....\$239
8512 COLOR.....\$449
8513 COLOR.....\$539



RUSH SERVICE AVAILABLE. CALL FOR DETAILS.

Certified Check/Bank Check, Approved P.O.s, Money Orders, Visa, Am-Ex, Diner's Club, Carte Blanche, & C.O.D.s accepted. No additional surcharge for Credit Card orders. Non-certified checks must wait 4-6 weeks for clearance. N.Y. residents add applicable sales tax. Prices and availability subject to change without notice. Not responsible for typographical errors. Return of defective merchandise must have prior return authorization number or returns will not be accepted. IBM PC/XT are registered trademarks of International Business Machine Corp. APO FPO orders please add 5% shipping and handling. All APO/FPO orders are shipped first class priority air. All orders can be shipped Air Express. Call for details. DCA #00223

10 YEARS

EPSON[™] LQ-500 24-PIN PRINTER

50% OFF

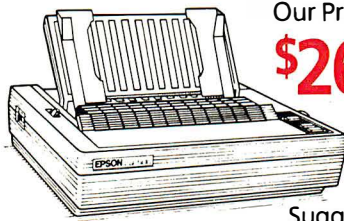

Our Price
\$269*

Suggested Retail **\$529**

*Price reflects \$25 manufacturer's rebate good thru 5-31-89

EPSON[™] LX-800

40% OFF

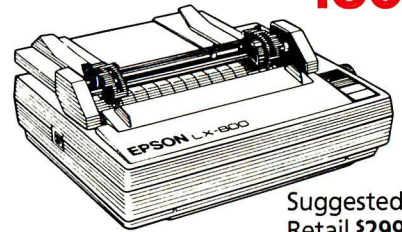

Our Price
\$180

Suggested Retail **\$299**

We carry all Epson products at comparable savings.

WAREHOUSE DATA

PRODUCTS
Division of
AZ Computer Corporation

2727 W. Glendale Ave., Phoenix, AZ 85051
Phone Hours: Mon. thru Fri. 6:30 AM-9:00 PM MST
Saturday 9:00 AM-5:00 PM MST
Technical Support: 1-800-421-3135

TO ORDER IN THE U.S.A. & CANADA

1-800-421-3135

We Welcome International Accounts
Call Our Fax Line (602) 246-7805

THE FAX

CORNER

The Complete FAX

Complete FAX 9600

40% OFF

Sug. Ret. \$699 Our Price **\$412**

SHARP

Sharp UX350 FAX
G3 & G2 Compatible

35% OFF

Sug. Ret. \$2399 Our Price **\$1520**

SPECIALS

Major Brand Name
Daisy Wheel Printer

60% OFF

Sug. Ret. \$1195 Our Price **\$499**

CLARION
PROFESSIONAL
DEVELOPER[™]

45% OFF

All New Version 2.0
Sug. Ret. \$695 Our Price **\$385**

SOFTWARE

ACCOUNTING	INTEGRATED	LANGUAGES	UTILITIES
ACCPAC BPI.....\$234	Enable OA.....\$352	Flowchart II Plus.....\$142	Allways.....\$85
Dac Easy Acct. 3.0.....55	Microsoft Works.....83	Microsoft C Compiler	Copy II PC.....19
Dac Easy Payroll.....55	PFS: 1st Choice 3.0.....88	Ver. 5.0.....295	Deskview Ver. 2.2.....72
Dollars & Sense.....94	Smart System.....380	MS Fortran Ver. 4.1.....295	Fastback Plus.....104
Managing Your Money 5.0.....117	DESKTOP PUBLISHING	MS Macro Assembler	Fastrax.....30
Peachtree Complete.....149	Pagemaker Ver. 3.0.....\$475	Ver. 5.1.....98	Formworks w/Fill & File.....85
Quicken 2.0.....28	PFS: First Publisher 2.0.....73	MS/Quick Basic 4.5.....59	Graph in the Box 2.....73
DATA BASE MANAGERS	Ventura Publisher 2.0.....449	MS/Quick C.....65	Mace Gold.....79
Clipper.....\$410	COMMUNICATIONS	Turbo Basic 1.1.....65	Microsoft Windows 286
Data Perfect.....283	Carbon Copy Plus.....\$105	Turbo C Ver. 2.0.....90	Ver. 2.1.....65
DBase IV.....463	PC Anywhere III.....69	Turbo Pascal 5.0.....93	Norton Advanced.....75
DBase IV Developers Ed.....799	Procomm Plus.....42	SPREADSHEET	PC Tools Deluxe.....37
DB-XL Diamond.....115	PROJECT MANAGER	Lotus 1-2-3 w/Allways.....\$285	PC Tools 120.....120
Paradox 3.0.....435	Timeline Ver. 3.0.....\$364	Lucid 3D.....79	Timeslips.....113
Fox Base Plus 2.1.....190	Harvard Total Proj. Mgr.....369	MS/PC Excel 2.1.....240	CAD/GRAPHICS
Paradox 3.0.....435	MULTI-USER SOFTWARE	Quattro.....156	Design Cad 2D & 3D.....\$148
PFS: Profile.....165	Fox Base +.....\$299	Plan Perfect.....189	Generic Cad Level 3.....99
Q&A 3.0.....215	Microsoft Word.....205	WORD PROCESSING	Grasp.....79
Quicksilver Diamond.....329	Word Perfect.....339	Grammatic III.....\$49	Harvard Graphics Ver. 2.1.....265
Revelation Advanced.....460	WORD PERFECT	SPF/PC.....165	PFS: First Pub. Ver. 2.0.....73
RBase for DOS.....425	Word Perfect.....339	Word Perfect Ver. 5.0.....219	Printshop.....33
		Word Perfect Library Ver. 2.0.....65	Showpartner F.X.....199
		Wordstar Pro 5.0.....239	

HARDWARE

COMPUTERS	HARD CARDS	LOGITECH	INTEL
ARC Pro Turbo 286.....Call	Plus 20 MB.....\$519	Clear.....\$63	Above 286 Plus.....416
ACER	Plus 40 MB.....649	HiRes.....73	Above 286 I/O.....469
710 w/o Monitor.....\$785	HARD DRIVES	PS/2.....57	Connection Co-Processor.....739
900 w/o Monitor.....1199	SEAGATE	Scanman	ORCHID
AT&T	ST-225 20 MB w/cont.....\$259	PRINTERS	Ram Quest Extra PS/2.....339
6286 WGS.....1499	ST-238 30 MB w/cont.....279	CITIZEN	Tiny Turbo.....289
6300 WGS.....899	40 MB AT 251.....349	120D.....\$146	MODEMS
6386 WGS, 40MB H.D.....2999	MONITORS	OKIDATA	EVEREX
TOSHIBA LAPTOPS	Amdek 410.....\$145	OKI 320.....359	300/1200 w/Soft.....\$69
T 1200 FB.....\$1569	Mitsubishi Diamond.....509	OKI 390.....499	2400 EXT. Error Cor.....189
T 1200 HB.....2419	Princeton Max 15.....249	PANASONIC	HAYES
T 1600.....3359	Princeton Ultrasync.....509	1124.....339	1200B INT w/Soft.....289
T 3100 E.....2839	Samsung Amber Flat.....89	1180.....189	US ROBOTICS
T5200 140.....6389	Samsung RGB.....249	STAR MICRONICS	2400 w/o Soft.....335
VGA/EGA BOARDS	Samsung EGA.....369	NX1000.....179	ACCESSORIES
ATI EGA Wonder 800.....\$229	Samsung Multisync.....449	NX 1000 Color.....238	Copy II PC Deluxe Bd.....\$101
ATI VGA Wonder.....312	Zenith 1490.....599	BOARDS	Curtis Ruby +.....69
Orchid Pro Designer.....299	MICE/SCANNERS	AST	Logical Connection 512K.....532
Paradise VGA Proff.....485	Complete Scanners.....\$149	Rampage 286 Plus.....\$509	Masterpiece +.....95
Vega VRAM.....485		EVEREX	150 Watt Power Supply.....69
		2MB Above PC/XT.....79	
		3MB Above AT w/o Mem.....89	
		Multifunction EMS.....95	

USER FRIENDLY TERMS & CONDITIONS:

- We welcome international accounts, please call for special pricing.
- Volume discounts for corporate and institutional orders.
- We do not charge your credit card until your order is shipped.
- Shipping minimum is \$5.00. Arizona orders + 6.7% sales tax.
- Personal/company checks allow fourteen (14) days to clear.

- All shipments insured at no extra cost.
- All prices are subject to change without notice.
- We do not guarantee compatibility.



Methodology: The Experts Speak

*Five prominent software engineers discuss the methodologies
for which they are famous*

*Ken Orr, Chris Gane, Edward Yourdon,
Peter P. Chen, and Larry L. Constantine*

The Warnier/Orr Approach

Ken Orr

It's more or less impossible to write about the Warnier/Orr methodology because, in fact, there is no such thing. While there are Warnier/Orr diagrams, Warnier's methodology (i.e., logical data structure, logical construction of systems, and logical construction of programs), and Orr's methodology (data-structured systems development), there is not, strictly speaking, a Warnier/Orr methodology.

Many software engineers confuse diagrams with methodologies. Perhaps this is natural, since the diagrams are the most visible part of most methodologies; but it's unfortunate, for methodologies are much more than just a set of diagrams and syntax rules.

Within the context of software engineering, a *method* is a procedure or technique for performing some significant portion of the software life cycle. Over the years, techniques have been developed for requirements definition, database design, program design, test-case development, and so on. A *methodology*, in software engineering terms, is a collection of methods based on a common philosophy that fit together in a framework called the systems development *life cycle*.

Methods often use a variety of tools: diagrams, forms, and text for documenting and communicating. Not surprisingly, these diagrams and forms often take on a life of their own. Diagrams, like words, can be used out of context, without understanding the purpose for which they were intended. While the results can be confusing, new possibilities and uses often arise that are quite fortuitous.

People who develop software engineering methods and methodologies attempt to solve problems, observe what others do, and derive, or abstract, patterns from all this. Those patterns ultimately turn into methodologies.

In my experience, my colleagues and I always know *what* works long before we know *why* it works. Software engineering methodologists are skilled at working with experts, such as analysts, programmers, database administrators, and so forth, finding out how these experts do what they do, and putting these findings down in such a way that others can follow them.

The correct name for what many people call the Warnier/Orr methodology is

data-structured systems development. DSSD, like most methodologies, is actually the result of many people's efforts, in addition to my own, including my co-workers at Optima, colleagues, and clients. Much of the methodology has come about by taking various component technologies, such as structured programming and relational-database design, and putting them together into a coherent framework.

A Little History

In 1972, Terry Baker's article "Chief Programmer Team Operations" in the *IBM Systems Journal* had a major impact on the field. It brought together several ideas: structured programming, top-down design and implementation, the chief programmer, the chief-programmer team, and the documentation librarian. If there was a shot that started the "structured revolution" in the U.S., Baker's article was it.

In the early 1970s, I became interested in structured programming and in structured design. In applying the principles of top-down design, I discovered that many of my best, most intelligible solutions were those in which the hierarchi-

continued

cal structure of the program mirrored the hierarchical structure of the data the program was processing.

Shortly after this discovery, I stumbled across the work of Jean Warnier and realized that he not only had made the same discovery with regard to data-structured programming but had already built a systematic methodology around it. I also followed Michael Jackson's work, another form of data-structured design.

I already believed that you could and should construct programs hierarchically using only a few basic logical structures. Moreover, I believed that if you were going to build very large things, you should build them in systematic ways based on simple structures. This coincided with design and construction techniques used in fields such as electrical engineering. Structured programming represented a base on which to build; therefore, using the data structure as the framework for building the program structure seemed like the next natural step.

Data-structured programming meant that you could create predictably correct solutions for a wide class of program-

ming problems—problems in which the structures of the input and the output were the same or very similar. But beyond that, Warnier, Jackson, and those of us involved in developing DSSD were able to extend data-structured techniques to arbitrarily complex programs.

To solve these more complex problems, you must recognize that the nature of the problem of complexity is, on one level at least, fundamentally mathematical in nature—that is, complex problems are fundamentally $n:n$ (many-to-many) mappings from input to output. To deal with this complexity systematically, you must break the problems down into a series of less complex mappings.

This is what mathematicians have been doing for thousands of years—breaking large troublesome problems into smaller ones for which there are clear precise answers. In the case of data-structured design, this meant developing a scheme in which the physical inputs were mapped into logical inputs; the logical inputs were then mapped into the logical outputs; and, finally, the logical outputs were mapped into the physical outputs.

With this overall program-design

framework comes a goal-oriented design strategy—an approach that starts with the structure of the output and works backward, first to the logical, or ideal, input, and then to the physical input.

The data-structured approach to program design has proven to be successful on a wide variety of problems, but it is clearly no panacea. What it does represent is a systematic approach to attacking complex problems (simple problems have a way of taking care of themselves, or, alternatively, becoming complex).

Programming in the Large

At some point in developing techniques for building systems, you realize that the most significant problems in software occur not at the programming level but at the systems level. How do you design entire suites of programs so that they work effectively together? How do you get the right requirements? Where does planning fit into the scheme of things?

Little by little, DSSD moved from a program-design methodology to a systems-design methodology. Over a period of years, the methodology was expanded to deal with database design, require-

continued

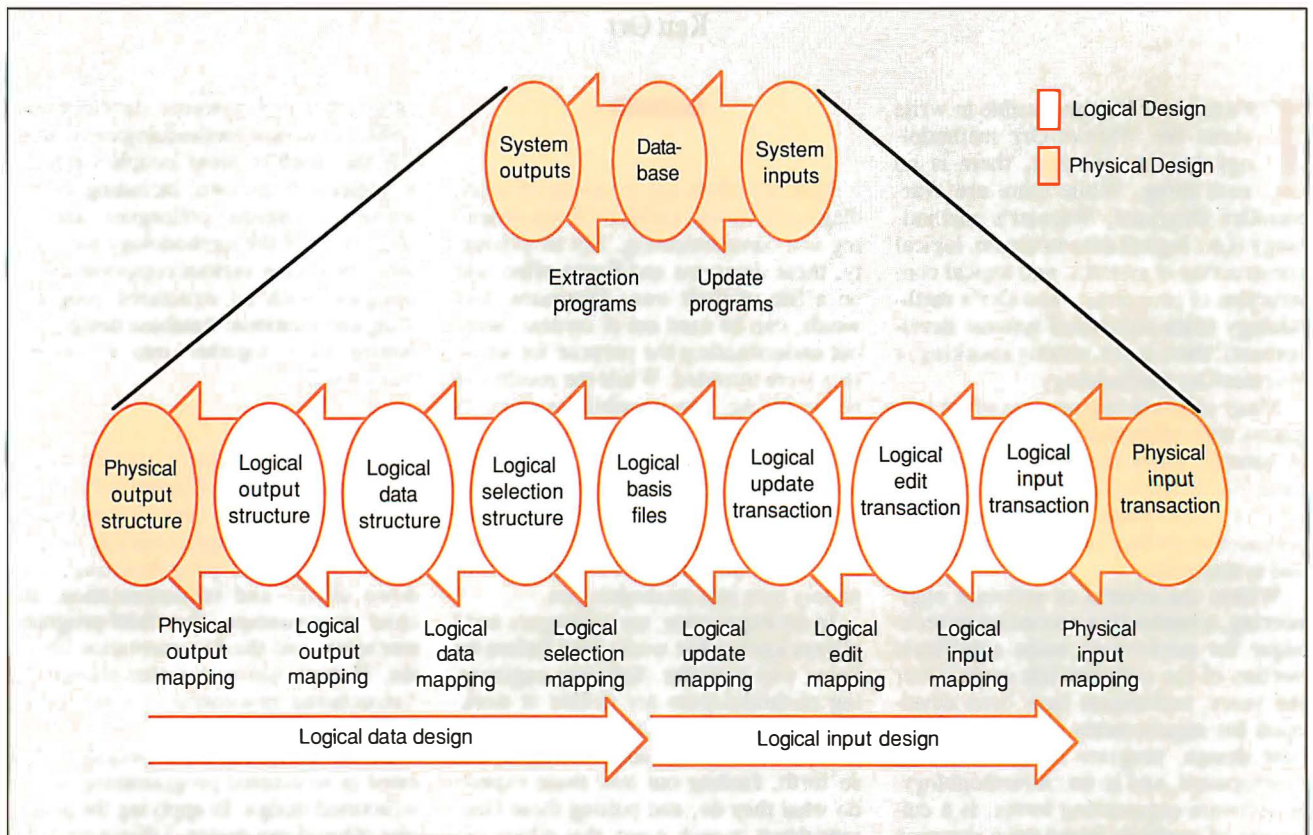

Figure 1: At the systems level, instead of working backward to the ideal inputs, DSSD works backward to the logical database and then to the inputs.

Doing Business Since 1980 A Division of CW Marketing, Inc.



**The Acknowledged Leader
in the Computer Mail Order Industry**
Call About the Availability of Other Products Not Listed.



PC/XT SYSTEM

10MHz, 640K Memory, 150 Watt Power Supply, AT Style Keyboard,
1-360K Drive, AT-Style Case, Monographics Card with Parallel Printer
Port, Clock Card with Serial Port, Mono Monitor with Swivel Tilt Base

\$709

System w/2-360K Drives . . . \$787

System w/1-360K DR 1-20 Meg . . . \$994
System w/1-360K DR 1-30 Meg . . . \$1021

IBM SOFTWARE

WORD PROCESSORS

Easy Extra	\$53
Grandview	175
Multimate Advantage II	275
PFS: Professional Write	102
Volkswriter 4	89
Volkswriter Deluxe Plus	57
Word (Microsoft)	179
Word Perfect 4.2	198
Word Perfect 5.0	219
Word Perfect Executive	117
Word Perfect Library	58
Wordstar Pro Pack	233
Wordstar 2000 Plus 3.0	239

DISKETTES

Maxell	Call
Sony 5 1/4 Qty. 100 DS/DD	\$65
Sony 3 1/2 Qty. 100 DD	145
Sony 3 1/2 HD Qty. 100	355

DESKTOP PUBLISHING

Pagemaker 3.0	\$459
PFS: First Publisher	69
Ventura Publishing	445

LANGUAGES

Basic Compiler (MS)	\$176
C Compiler (MS)	266
Cobol Compiler (MS)	531
Fortran Compiler (MS) 4.1	266
Macro Assembler (MS)	89
Pascal Compiler (MS)	179
Quick Basic	59
Quick C	59
Turbo Basic	62
Turbo C	88
Turbo Pascal 5.0	88
Turbo Pascal Dev. Library	228

GRAPHICS

Designer	\$399
Draw Plus	229
Generic CAD w/Dot Plot 3.0	72
Harvard Graphics 2.1	255
In-A-Vision	262
Microsoft Chart 3.0	234
News Room	30
PC Paintbrush Plus	69
Printmaster Plus	28
PrintShop	32
Publishers Paintbrush	132
Turbo Graphix Tool Box	62
VP Graphix	56

UTILITIES

Brooklyn Bridge	\$69
Copy II PC	18
Cruise Control	28
Disk Optimizer 4.0	37
Disk Technician Advanced	101
Disk Technician Plus	67
Fastback Plus	98
Mace Utilities	47
Microsoft Windows 286	59
Microsoft Windows 386	115
Norton Utilities 4.5	47
Sidekick Plus	125
Sideways	37
SQZ Plus	53
Take Two MGR	59
XTree Professional	61

DATA BASE MANAGEMENT

Clipper	\$405
DB-XL Diamond	107
Nutshell Plus	185
Paradox 2.0	403
PFS: Professional File 2.0	152
Q & A	199
R:Base For DOS	426

MONEY MANAGEMENT

Dollars & Sense w/Forcast	\$91
Tobias Manag. Your Money 5.0	114

COMMUNICATIONS

Carbon Copy Plus	\$106
CompuServe Subscription Kit	19
Crosstalk XVI	87
Crosstalk Mark IV	109
Mirror III	49
Remote 2	87
Smartcom II	79
Smartcom III	136

INTEGRATIVE SOFTWARE

Ability Plus	\$137
Enable 2.0	369
Framework III	409
MS Works	88
PFS: 1st Choice	82
Smart Software System	385
Symphony	409

MICE

PC Mouse w/paint (Buss or Serial)	\$81
PC Mouse w/Autosketch Buss	97
w/Autosketch Serial	97
Microsoft Buss Mouse 1.0	95
Microsoft Serial Mouse 1.0	95
MS Buss Mouse w/CADD	109
MS Buss Mouse w/Windows	125
MS Serial Mouse w/CADD	109
MS Serial Mouse w/Windows	125

SPREADSHEET

Cambridge Analyst	\$80
Lotus 1-2-3 Ver. 2.01	285
Lotus Manuscript	299
MS Excel	215
MS Excel/Mach 20 Bundle	620
Multiplan 4.0 Microsoft	116
Quattro	146
Supercalc 5.0	305
VP Planner	47
VP Planner Plus	112

IBM HARDWARE

PRINTERS

ALPS	
Allegro	\$345
All Other Models	Call
AST TurboLazer	2865
Brother	
M1109	139
LAZER	Call
Other Models	Call
Citizen Printers	
1200	145
1800	165
All Other Models	Call
Diconix	
150	305
Epson	
FX850	355
LQ850	555
LQ500	295
LX800	175
All Other Models	Call
Hewlett-Packard	
Laser Jet Series II	1785
Paint Jet	1085
Desk Jet	725
NEC	
P2200	339
P5200	505
P5300	679
Other Models	Call
Okidata	
320	319
321	449
390	449
New Lasers	Call
All Other Models	Call

MODEMS

Panasonic	
1124	319
1180	185
1191	249
All Other Models	Call
Star Micronics	
NX 1000	169
NX 1000 Rainbow	225
NX 2400	305
All Other Models	Call
Toshiba	
311	385
Pagelazer	2535
Anchor	
1200B w/Software	60
2400EXT	135
2400B w/Software	119
Hayes	
All Models	Call
Prometheus	
1200B w/Software	70
2400B w/Software	125
Other Models	Call
US Robotics	
9600	589
2400	125
All Other Models	Call

NETWORKING

Novell	Call
-------------------------	------

HAND SCANNERS

Complete	
400	\$139
Half Page	175

DISK DRIVES

Bernoulli Box	
10 Meg	\$889
20 Meg	1250
Beta Int 20 Meg	765
Headcards	
Plus 20 MG Hardcard	509
Plus 40 MG Hardcard	645
Passport	Call
Magnum Tape Back Up	
44 MG	340
Seagate	
20 MG w/WD Controller	275
251-1 40 Meg AT	435
40 MG w/Controller	439
All Other Models	Call
Teac	
1.2 MGAT	85
Floppy 360K	70
Toshiba	
3.5 Dr 720K	79
3.5 Dr 1.4 MG	99

KEYBOARDS

Keytronics	
KB101 +	\$85
KB5151	119

TERMINALS

Wyse	
30	\$295
50	370

FAX MACHINES

Brother	
150	\$919
Sharp	Call

BOARDS

AST	
Six Pack Plus w/384K	\$269
VGA+	329
All Other Models	Call
ATI	
EGA Wonder	225
VGA Wonder	305
Hercules	
Graphics Card Plus	175
All Other Models	Call
Intel	
Inboard 386 PC	720
Co-processors	Call
Aboveboard	Call
Orchid	
Designer 800	235
Pro Designer	295
Pro Designer+	385
Tiny Turbo 286	255
Paradise	
Autoswitch 350	155
Autoswitch 480	170
All Other Models	Call
Video-7	
Fastwrite VGA	345
VGA	265
Vega deluxe	205
Zenith	
449	239

FAX BOARDS

Complete	
4800	\$225
9600	389

COMPUTERS

Amstrad	
Dual Drive	\$775
Single Drive	775
AST	
Model 80	1430
Other Models	Call
Toshiba	
T-1000	789
T-1200FB	1569
T-1800	3375
T-3200	3665
T-5100	4795
Zenith	
Supersport/2	1655

MONITORS

Amdek Monitors	
210A	\$80
410	135
Mitsubishi	
Diamond Scan	499
NEC	
Multisync II	589
Multisync Plus	899
Multisync 3D	Call
Other Models	Call
Princeton	
Ultrasync 12"	499
Ultrasync 16"	839
Other Models	Call
Sony	
Multiscan (1303)	535
Zenith 1490	599



No Charge for VISA and Mastercard.
We Do Not Charge Your Card Until Your Order is Shipped.
All products including D.O.A.s, carry only manufacturer's warranties. We do not honor guarantees, rebates, trial period privileges or promotional programs offered by manufacturers.
No returns on used or misordered product.
You Pay The Ground Shipping 1-10# \$6.00; 11-20# \$10.00 (Except Alaska & Hawaii). We Pay the Air Difference.

Free Air Applies ONLY to Orders Over \$100.
No APO, FPO, or international orders please.
Call Before Submitting P.O.s. Ask for National Accounts.
Personal and Company Checks Will Delay Shipping 3 Weeks.
Prices, Terms & Availability Subject to Change Without Notice.
Add \$5 for C.O.D. Orders.
We Do Not Guarantee Machine Compatibility.
Mailing Address: TELEMART, 8804 N. 23rd Ave., Phoenix, AZ 85021.

To Place an Order: 1-800-634-9270.
To Follow Up On an Order: (602) 944-1037.
Order Line Hours:
Mon.-Fri. 7:00 am-6:00 pm
Saturday 9:00 a.m.-1:00 p.m.
Order Processing: (602) 944-1037
10:00 a.m.-3:00 p.m. Mon.-Fri.



ments definition, and finally systems planning and architecture.

At a conceptual level, DSSD still retains features that characterized it at the programming level. For example, it still focuses (in its design phase) on working backward from outputs. But at the systems level, instead of working backward to the ideal inputs, as it does in the programming methodology, DSSD works backward to the logical database and then to the inputs (see figure 1). The logical database turns out, not surprisingly, to be a normalized relational database.

While a complete definition of the results (outputs plus algorithms) is an excellent point at which to begin the design process, it is not the proper place to start requirements definition. So, over the years, DSSD has been extended to cover first the context, then the functions, and finally the results of the system in question.

Thus, a number of tools were needed to facilitate this process. *Entity diagrams* help you define the systems context, and *assembly-line diagrams* (a modified form of Warnier/Orr diagrams) help you define the functional flow of the system.

Data-structured methodologies have, I believe, a leg up on more process-oriented methodologies, since they are more rigorous and hence provide a better basis for true integration throughout the systems life cycle. DSSD has been used successfully on a range of software systems, from commercial on-line systems to real-time control systems. Thousands of people have been trained and thousands of systems have been built using it.

DSSD is a software engineering approach that has provided a stable framework for incorporating new technologies as they come along. For example, we have incorporated prototyping, on-line, and real-time design into DSSD without sacrificing the rigor or completeness. But there is a catch: To use DSSD successfully, you must invest time in training, use, and automation. In software engineering, as in life, there is no free lunch.

BIBLIOGRAPHY

Hansen, Kirk. *Data Structured Program Design*, 2d ed. Englewood Cliffs, NJ: Prentice-Hall, 1986.

Higgins, David A. *Designing Structured Programs*. Englewood Cliffs, NJ: Prentice-Hall, 1983.

Jackson, Michael A. *Principles of Program Design*. New York: Academic Press, 1975.

Orr, Kenneth T. *Structured Systems Development*. New York: Yourdon Press, 1977.

_____. *Structured Requirements Definition*. Topeka, KS: Ken Orr & Associates, 1980.

Warnier, Jean-Dominique. *Logical Construction of Programs*. New York: Van Nostrand Reinhold, 1976.

_____. *Program Modification*. Boston: Martinus Nijhoff, 1978.

_____. *Logical Construction of Systems*. New York: Van Nostrand Reinhold, 1981.

Ken Orr is president and chief scientist for Optima in Schaumburg, Illinois, and a principal of the Rosetta Institute in Topeka, Kansas. He is a frequent lecturer and the author of several books and articles on programming, systems and database design, and CASE. He can be reached on BIX c/o "editors."

The Gane/Sarson Approach

Chris Gane

When we think about an information system that doesn't exist yet, our ideas are usually pretty vague and general. This is not an accusation; it's a fact of human psychology.

The purpose of logical modeling is to take these necessarily vague ideas about requirements and convert them into precise definitions as fast as possible. Part of the speed comes from having graphical techniques that enable you to put down the essence of a system without going through the trouble of actually physically implementing it, as you might do, for example, in a prototype.

Several approaches to logical modeling have been proposed. The one outlined here is the current version of the approach set out in a book I wrote with Trish Sarson (see reference 1). It has become generally known as the Gane/Sarson methodology.

Logical Modeling

You can think of logical modeling as a seven-step process. Suppose the users

say, "We need a system that integrates sales, inventory control, and purchasing." What exactly does that mean?

• *Step 1.* Develop a system-wide data-flow diagram (DFD) describing the underlying nature of what occurs in the sales, inventory control, and purchasing areas of the business. The simplicity of the DFD comes from the use of only four symbols to produce a picture of the underlying logical nature of any information system, at any desired level of detail.

Figure 1 shows CUSTOMERS (an external entity, something outside the system) sending in a stream of sales orders along the data-flow arrow. Process 1, process sales, handles those orders using product information from the data store called D1: PRODUCTS and puts information about sales into the data store named D3: SALES.

This figure also shows the whole of the business area, depicted using only the

four symbols. For each sale, process 1 updates the INVENTORY data store, D2, with the units sold. The data stored in D3 is used by processes 2 and 3 to prepare bank deposit documents and send them to the bank, and to prepare sales reports and send them to management.

At some appropriate time—notice that time is not shown on the DFD—process 4 extracts information about the inventory status of various products from D2 and combines it with information from D3 concerning their past sales, to determine whether a product needs to be reordered. If so, based on information in D4, which describes the prices and delivery times quoted by suppliers, process 4 chooses the best supplier to order from.

Process 4 sends purchase orders to the external entity SUPPLIERS and stores information about each purchase order in D5: POS_IN_PROGRESS. When a shipment is received from a supplier, process 5 analyzes it, extracting data from POS_IN_PROGRESS to determine whether what has been received is what

continued

ACCESS to Control Systems

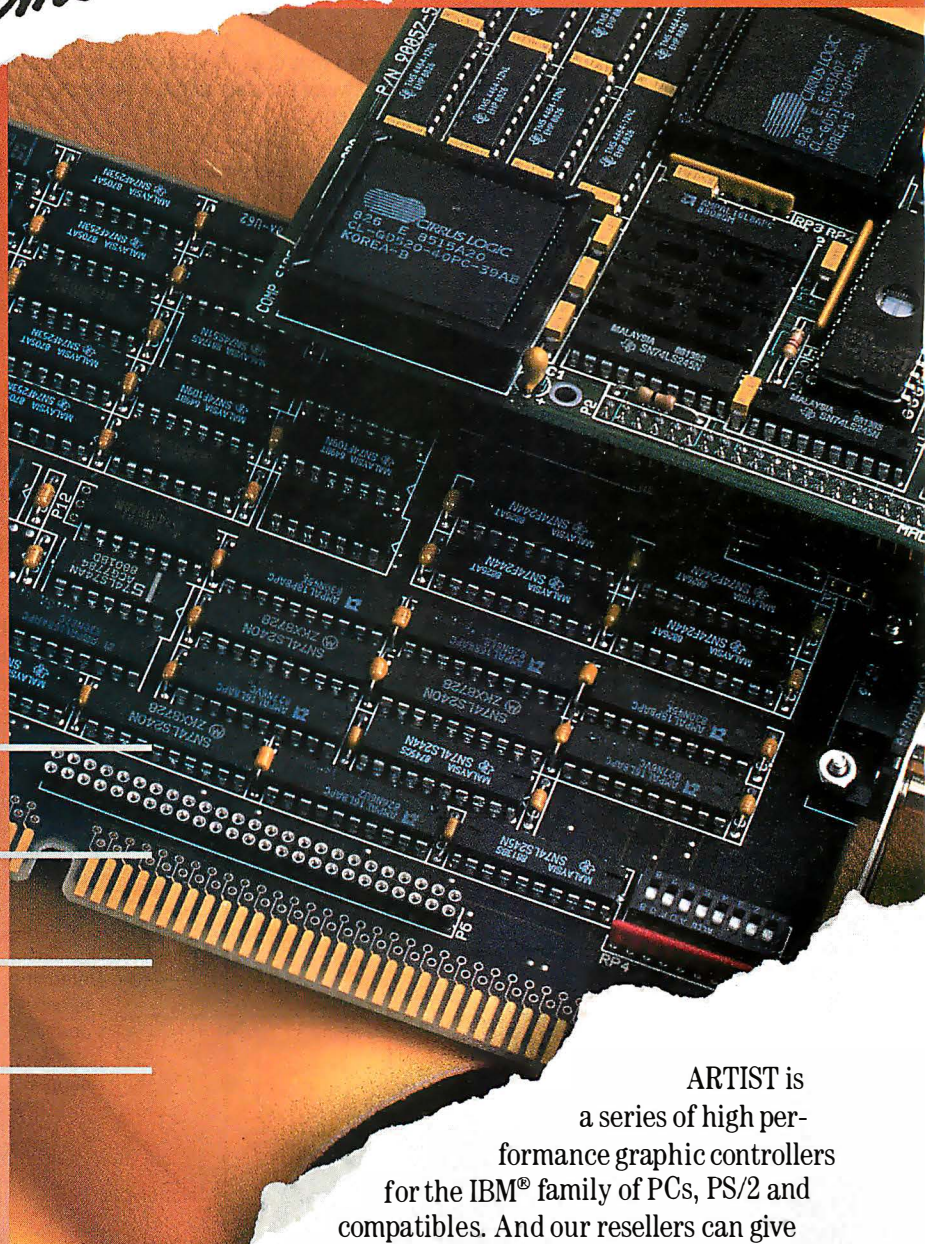

When you buy
ARTIST™ from an
ACCESS reseller,
you'll get
even more control.

ARTIST is a series of high performance graphic controllers for the IBM® family of PCs, PS/2 and compatibles. And our resellers can give you access to all of them. Twenty controllers in all, with resolution from 800 × 600 to 1664 × 1200; compatibility with over 200 CAD and other graphics software products; VGA, EGA, and CGA modules for single screen workstations and to run software that supports IBM graphic standards; PC and MC Bus compatibility; and developer toolkits for PGL, DGIS, X-Windows and Hoops.

Best of all, when you buy through an ACCESS reseller, you're assured that our knowledge and experience is behind the sale. Because ACCESS is the only national graphics equipment distributor with on-going training, performance guarantees and reseller support. So why buy from just anyone, when you can buy from a reseller with ACCESS to graphics technology.

 **Control Systems**
1-800-826-4281. In Canada: 1-800-543-6523

ACCESS Graphics Technology — The National Graphics Distributor.
For resellers in your area call 1-800-443-4223

Circle 316 on Reader Service Card

was ordered, incrementing the INVENTORY, D2, with the accepted amount, and storing the accepted quantities in POS_IN_PROGRESS.

This DFD achieves three things. First, it sets a boundary to the area of the system and of the business covered by the system. Things represented by the external-entity symbol (i.e., customers, the bank, management, and suppliers) are, by definition, outside the system. Processes not shown are not part of the project. For example, the diagram shows receiving shipments from suppliers but not handling the invoices received from them, implying that accounts payable is outside the scope of the project as well.

Second, it is nontechnical. Nothing is shown on a DFD that is not easily understandable to people familiar with the business area depicted, whether or not they know anything about computers.

Third, it shows both the data stored in the system and the processes that trans-

form that data. It shows the relationships between the data and the processes in the system.

- *Step 2.* Derive a first-cut data model—that is, a list of the data elements to be stored in each data store, as defined on the DFD. You should draw up this list from your own knowledge and from the knowledge of users about what information you need to describe a product, a supplier, a sale, and so on.

You can refine the list by looking at each system input, such as sales orders or shipments in figure 1, determining what data elements each input represents, looking at each output in the same way, and then working from the outputs back to the data stores or from the inputs forward to the data stores.

- *Step 3.* See what entity-relationship analysis can tell you about the structure of the data to be stored in the system.

First, you ask, “What are the entities of interest about which I may need to store data?” For this business, the answer might be CUSTOMERS, PRODUCTS, INVENTORY, SUPPLIERS, SALES, and PURCHASE_ORDERS. Then, you create a diagram with a block for each entity you have identified. (It is conventional in this diagram to state the entities as singular nouns—for example, CUSTOMER instead of CUSTOMERS.)

Next, looking at each pair of entities on the diagram, you ask, “What, if any, relationships exist between them?” For example, you know that one customer may be associated with many sales, but each sale can be for only one customer. This is conventionally shown by a line with an arrowhead against the “many” block and a plain line at the “one” block.

Take, for instance, PRODUCT and SALE: One product may be associated with many sales, and one sale may be for many products—at least one, and possi-

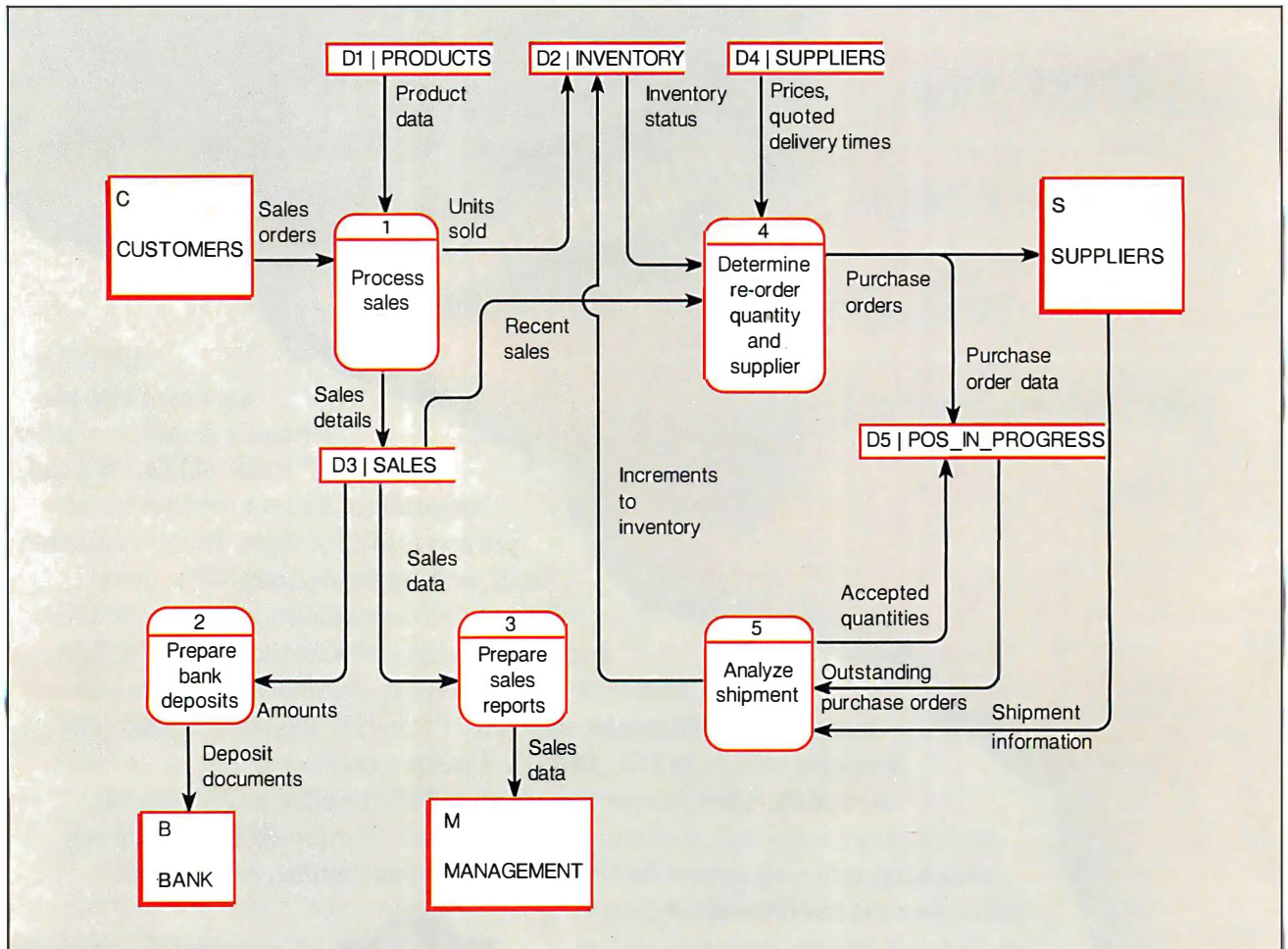

Figure 1: A DFD for the whole of the business area. Note the box for external entities, the open rectangles for data stores, the rounded box for the process, and the data-flow arrow, which shows the direction of data movement. Notice also that time is not shown on a DFD.

bly more. This relationship is shown by a line with an arrowhead on both ends. On the other hand, each product has only one inventory record, and each inventory record refers to only one product. Consequently, they are joined by a simple line. Adding in all the identifiable relationships creates a diagram like figure 2.

- *Step 4.* Use all the information you have about the data so far to describe the data model as one made of linked, two-dimensional tables. These tables should be *normalized* (i.e., made as simple as possible). One way to summarize the rules of normalization is to say that in a properly simplified table, in which a column or combination of columns uniquely identifies each row (the key), each non-key column should depend only on the key.

- *Step 5.* Redraft the DFD to reflect a more precise view of the system data as a result of entity-relationship analysis and normalization.

- *Step 6.* Partition this logical model of process and data into *procedure units*—that is, chunks of automated and manual procedures that can be executed (and therefore developed) as units. To do this, you consider each input and output and ask the following questions for each one:

1. When does it happen?
2. How large an area of the DFD is involved in handling or producing it?
3. Can that area be implemented as a single unit? If not, why not?

- *Step 7.* Specify the details of each procedure unit that will be required to im-

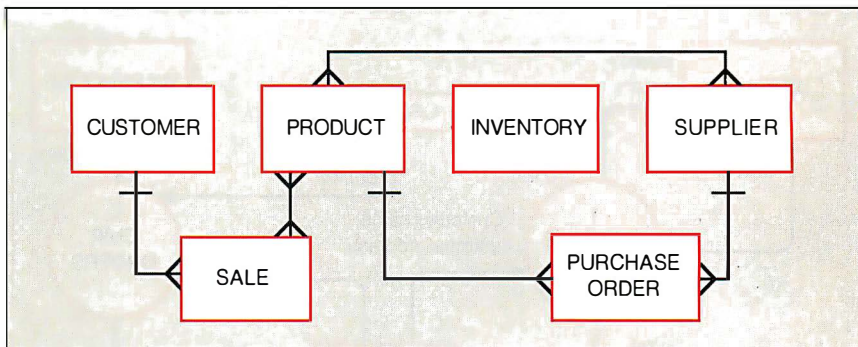

Figure 2: All the identifiable relationships between entities. For each pair of entities on the diagram that has a relationship between its elements, the relationship may be one-to-one, one-to-many, many-to-one, or many-to-many. This diagram provides a lot of information about the system in showing all the relationships that exist between the entities involved.

plement the system. A procedure-unit specification may involve

1. an extract from the system DFD showing where this procedure unit fits into the rest of the system;
2. details of the tables accessed by the procedure unit;
3. layouts for any screens and reports involved in the procedure unit; and
4. details of the logic and procedures to be implemented, written in structured English or some other unambiguous form.

With the nature of the procedure unit defined, you can decide whether it should be prototyped or implemented directly in the target language. You can develop the screen and report layouts by prototyping.

Steps 6 and 7 in this sequence are not, strictly speaking, logical modeling, since they deal with converting the logi-

cal model into a physical model. They are included, however, because they form part of the natural flow of thought processes beginning with defining the system and ending in its physical design.

Editor's note: Chris Gane extracted this article from Chapter 1 of his book Rapid System Development, published by Prentice-Hall in December 1988.

REFERENCES

1. Gane, Chris, and Trish Sarson. *Structured Systems Analysis*. Englewood Cliffs, NJ: Prentice-Hall, 1979.

Chris Gane is president of Rapid System Development in New York City and principal consultant at Bachman Information Systems in Cambridge, Massachusetts. He is the author of several books, including Rapid System Development (Prentice-Hall, 1988). He can be reached on BIX c/o "editors."

The Yourdon Approach

Edward Yourdon

The Yourdon method is a generic, ecumenical collection of software engineering ideas developed over the past 20 years by a variety of people who have worked at Yourdon, Inc. Taken together, these ideas are often referred to as *structured techniques*: structured programming, structured design, and structured analysis.

Because of the continuing influx of new ideas from new people, the Yourdon

method is constantly evolving. The method that thousands read about in Tom DeMarco's book in 1978 (see reference 1) has changed considerably in the past 10 years. And the Yourdon method of 1989 is evolving to incorporate the best ideas of object-oriented design and analysis.

But what *is* the "Yourdon method" to-

day? It consists of two things: tools and techniques. The tools are a variety of graphical diagrams used to model the requirements and the architecture of an information system. The most familiar of these tools is the data-flow diagram (DFD) (see figure 1). The original DFD notation was extended a few years ago to support real-time systems; a real-time DFD includes control flows and control processes. For a detailed description of

continued

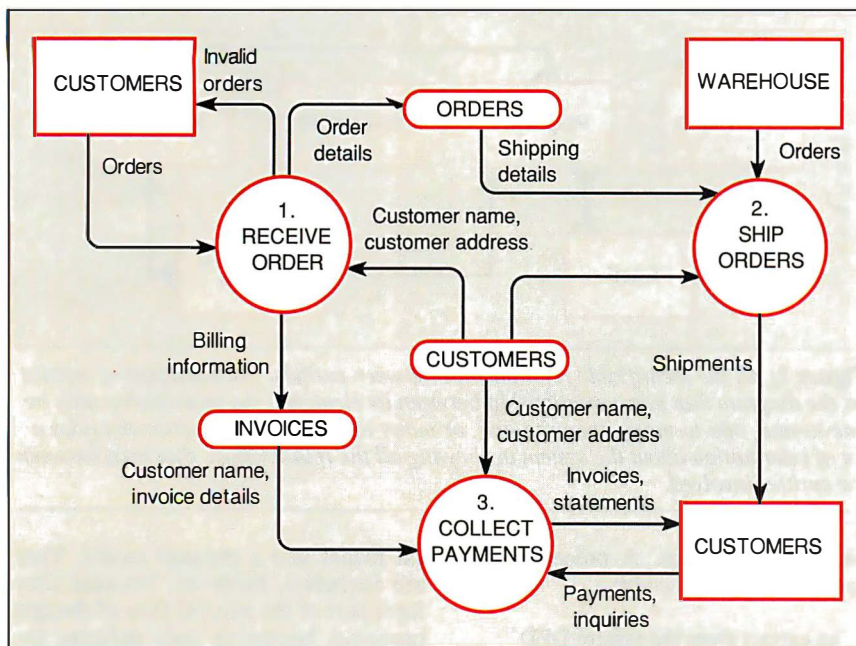

Figure 1: A data-flow diagram. The DFD models the functions that a system must perform.

real-time DFDs, see reference 2.

While the DFD is an excellent tool for modeling the *functions* that a system must carry out, it says little or nothing about data relationships and time-dependent behavior. Thus, the current Yourdon method also includes entity-relationship diagrams (ERDs) and state-transition diagrams (STDs) (see reference 3).

After you have finished describing the system requirements, you can use a structure chart to illustrate the organization of modules that will implement those requirements. A number of guidelines exist that the systems analyst can follow to ensure that each diagram is complete and logically consistent.

While the graphical diagrams provide an effective way of communicating information about different aspects of a system, they don't tell the whole story. For a complete system description, you need additional textual support: a data dictionary, which describes the composition of each data element, and a set of process specifications that describe the required behavior of each bottom-level "bubble" in the DFD.

The Techniques

The techniques of the Yourdon method consist of some "cookbook" guidelines that help you go from a blank sheet of paper, or a blank screen, to a well-organized system model. Originally, these guidelines were based on the simple concept of top-down partitioning of system

functions (e.g., draw a single bubble or box to represent the entire system, then draw lower-level bubbles or boxes to represent subsystems, and so forth).

Today, the Yourdon method uses a technique known as *event partitioning* (see reference 4). This approach begins by drawing a top-level *context diagram* to identify the system boundary and to define the interfaces between the system and external sources and sinks. Then, after interviewing the user, you can write a list of the *events* that occur in the external environment and to which the system must respond. (Events are often input transactions.)

The event-partitioning approach provides a simple guideline to help you compose a first-cut crude DFD: For each event, draw one bubble whose function is to provide the required response to the event. (In most cases, the response involves generating an output, but it may also involve storing some information in a data store to be used by some subsequent event.)

For a system with 100 events, the DFD would have 100 bubbles. This is too complex to work with, so the event-partitioning technique provides guidelines to help you partition *upward*—that is, to gather several of the DFD bubbles together and represent them by a single bubble in a higher-level DFD. The strategy for deciding which bubbles should be grouped together is to look for bubbles that deal with common data (e.g., a common data

store). In this sense, event partitioning is very similar to the object-oriented design approach.

There are various additional guidelines and techniques to help you compose well-formed models of both system requirements and system architecture. (One book that discusses both the analysis area and the design area—as well as the "twilight zone" that separates the two—is given in reference 5.)

The Yourdon Philosophy

Throughout all of the Yourdon method—regardless of variant or dialect, whether you draw circles or ovals in your DFD, or where you hear about it—you will see the following philosophies.

- *Modeling is good.* Developing a model of a system before you build it is almost always a useful, educational activity. For this to work, however, the model has to be inexpensive and easy to build: If it costs as much to develop the model as to develop the system, it's obviously a waste of time. The model also has to be accurate—it should not mislead you or lie to you. And it should be easy to understand: It should highlight those aspects of the system that are important, and it should deemphasize or hide those aspects that are unimportant or uninteresting.

Since most systems are complex in three different dimensions—functions, data, and timing and control—it is useful to have three different types of models, DFDs, ERDs, and STDs, each of which illustrates a single perspective of the system. The Yourdon method is based on abstract, pictorial models—either on paper or on a computer screen.

Another approach is to develop a prototype of the system as a model—a living, breathing model instead of a passive collection of diagrams. When prototyping was first introduced in the early 1980s, it was considered an alternative to paper-based modeling approaches—the systems analyst was often told to make a binary choice between prototyping and drawing DFDs.

Today, we know that the two approaches are complementary: You can draw diagrams as a permanent record of system requirements and use prototyping to experiment with such key issues as the user interface (input screens, report layouts, and so on). For a good discussion of the marriage of prototyping and "classical" structured analysis, see reference 6.

- *Iteration is good.* As fallible humans with limited intelligence, we rarely, if

continued

INTRODUCING 4 NEW WAYS TO AVOID MAKING COSTLY FINANCIAL MISTAKES.



MANUFACTURERS HANOVER

FINANCIAL PLANNING SERIES

MHT's Financial Planning VHS Tapes. Buy 2, Get 1 Free!

These tapes offer four smart ways to avoid making costly financial mistakes. Developed by a Certified Financial Planner, each is filled with valuable money-saving ideas. They're smart to give, smart to get.

PRINCIPLES OF FINANCIAL PLANNING

Kathleen Covey, CFP. Prevent costly errors by learning:

- how to evaluate your savings and investments needs and options, how to diversify your investments and protect yourself from economic cycles.
- how to prevent inflation and taxes from eroding your savings and investment returns.
- how much life, disability, property, and liability insurance you may need, and what to look out for.

LOW-RISK SAVINGS/ INVESTMENTS

Charles Lefkowitz, CFP. Assess investment risks by learning:

- why tax-exempt savings and investments could end up costing you money.
- how Unit Investment Trusts, Mutual Funds, Mortgage-Backed Securities, Annuities, Tigers, Strips, and Zero Coupons may provide higher returns than what you're now getting.
- how you could lose your shirt on bonds because their ratings do not tell the whole story. How "Call Features" interest changes, and other factors could ruin your rate of return.

FINANCIAL PLANNING AFTER 50

Arden D. Down, CFP. Secure your financial future by learning:

- how to evaluate your company

pension/profit-sharing plan so that you won't be surprised at retirement.

- how to design an asset-allocation investment plan to minimize risk and incorporate tax-advantaged strategies for future income needs.
- how to judge which makes the best tax sense: lump sum, rollover, or averaging your pension distribution.

HOME BUYING

Kathleen Covey, CFP, and Arden D. Down, CFP. Learn all aspects of the home-buying process:

- what are the differences between assessed value and appraised value; appraised value versus market value? Not knowing might cost you.
- learn more about the "hidden" costs of owning a house, a co-op, or condo. Closing and other costs are often underestimated. Buyers beware.
- which is better, a mortgage with points or without? What's deductible under the new tax law?
- what are ARMS, CAPS, amortization, escrow, titles, private mortgage insurance, etc.? Understanding the jargon could save you money.

Call now to order your gift.

1-800-533-0552

Our operators are standing by 24 hours a day, 7 days a week. Or, complete the coupons below and mail to:

Manufacturers Hanover
P.O. Box 3769, N.Y., N.Y. 10163

Titles	Send Me (qty.)	Cost	Total Cost
PRINCIPLES OF FINANCIAL PLANNING		X \$39.95 =	
LOW-RISK SAVINGS/ INVESTMENTS		X \$39.95 =	
FINANCIAL PLANNING AFTER 50		X \$39.95 =	
HOME BUYING		X \$39.95 =	
SUBTOTAL			
NY residents add local sales tax.			
\$2.50 per tape, shipping and handling.			
TOTAL			

My check is enclosed Charge to: Visa MasterCard
 Make check payable to Manufacturers Hanover Trust

Credit Card # _____

Signature _____ Exp. Date _____

Social Security # _____

Indicate your choice of one free tape:

PRINCIPLES OF FINANCIAL PLANNING FINANCIAL PLANNING AFTER 50
 LOW-RISK SAVINGS/ INVESTMENTS HOME BUYING

NOTE: Limit one free tape per order.

Send my order to:

My Name _____

Address _____

City _____ State _____ ZIP _____

() _____

Business/Home Phone _____

Offer expires 12/31/89. BY-4/89

ever, develop a perfect solution to a complex problem on the first attempt. At best, we can hope for a crude beginning that, through iteration, we can gradually refine and improve. To practice iteration, we must have models that are easy to create and easy to revise. In the past, we grappled with the finality of pen and ink; with the word processors of today, most of us take iteration for granted in composing reports and memos.

In systems development, we tried to make iteration of system models easier by insisting on partitioning the overall system model into a number of separable submodels. Thus, if one aspect of a system changes, ideally only one page of a diagram has to be modified. As a practical matter, though, most systems analysts in the 1970s and early 1980s drew DFDs only once—on paper. This is one reason why today's microcomputer-based computer-aided software engineering products are so important: They make iteration a practical reality.

• *Partitioning is good.* When we first learned how to write computer pro-

grams, we were given simple problems that we could finish in a day or two, keeping every aspect of the problem in our heads at once. With real-world programming problems, however, the only way we can successfully build systems that, today, typically involve more than a million lines of code is by partitioning the system into smaller and smaller pieces.

There are great debates about whether the partitioning should be based on functional decomposition or data decomposition. But either approach, followed rigorously, is better than no partitioning, or sloppy partitioning that leads to subsystems with subtle, pathological interconnections.

ACKNOWLEDGMENTS

The author gratefully acknowledges the contributions of the following people to the Yourdon method: Tom DeMarco, Larry Constantine, Chris Gane, Trish Sarson, Steve McMenamin, Tim Lister, John Palmer, Paul Ward, Steve Mellor, Meilir Page-Jones, Bob Block, Al Brill, Tim Wells, and Matt Flavin.

REFERENCES

1. DeMarco, Tom. *Structured Analysis and System Specification*. New York: Yourdon Press, 1978.
2. Ward, Paul, and Steve Mellor. *Structured Techniques for Real-Time Systems*. New York: Yourdon Press/Prentice-Hall, 1985.
3. Yourdon, Edward. *Modern Structured Analysis*. New York: Yourdon Press/Prentice-Hall, 1989.
4. ———. *Essential Systems Analysis*. New York: Yourdon Press/Prentice-Hall, 1984.
5. Page-Jones, Meilir. *The Practical Guide to Structured Systems Design*, 2d ed. New York: Yourdon Press/Prentice-Hall, 1988.
6. Connell, John, and Linda Schafer. *Rapid Prototyping*. New York: Yourdon Press/Prentice-Hall, 1989.

Edward Yourdon is an independent consultant and the publisher of a software engineering newsletter, American Programmer. He is an author in the field of structured systems development. His latest book is Modern Structured Analysis (Yourdon Press/Prentice-Hall, 1989). He can be reached on BIX c/o "editors."

The Entity-Relationship Approach

Peter P. Chen

One of the major problems in software engineering today is the piecemeal approach to systems design. This approach makes the integration of different application systems difficult, if not impossible. We try to design the data structures and formats to fit current processing needs and then later run into problems of data conversion and integration.

An integrated database is a solution to these problems. However, acquiring a DBMS does not make them go away. What is needed is a structured methodology that can systematically convert user requirements into well-designed databases. The entity-relationship (ER) approach is such a methodology.

Let's start with an example. Say you need a program to keep track of the list of employees working for each department in your company. This program needs to accept data on the screen, store it on disk, and print out the report on demand. The programmer/analyst comes up with a file format (see figure 1a).

In the meantime, another group in the company implements a program to keep track of employee information for each project; the file format in this program turns out a little different from the other (see figure 1b). Each program satisfies the needs of the group that requested it. However, one day the company president wants to know which departments have employees working on project X. Then everyone scrambles around trying to convert the data in one file to the format of the other file. Let's look deeply into these two file formats to see what kinds of problems they had.

- **Synonym (the same data element has different names):** For example, SOC_SEC_NO in figure 1a is the same data element as SS# in figure 1b.
- **The same name for different data elements:** For example, NAME in

figure 1a refers to the name of an employee, while NAME in figure 1b is the name of a project.

- **Incompatibility of data formats:** For example, the data-type format of AGE in figure 1a is Int(2), while the data format of AGE in figure 1b is Real(3.2).
- **Duplication of data:** For example, the project data (PROJ#, NAME) is duplicated for each employee associated with the project in figure 1b, and the BUDGET data of each department in figure 1a is repeated for each employee.
- **Update anomalies:** For example, changing any of an employee's data-element values in one file but not in the other will result in inconsistent data.

If the above file designs are not good, what would be a good design? How many record types (or relations in the case of relational databases) should there be? Should there be one huge record type

consisting of all data elements, or the other extreme—many small records, each consisting of a pair of data elements? Furthermore, what is the primary key for each record (relation) type? The main question is: Do we have a methodology for file and database design? The answer is yes, and the leading methodology is the ER approach.

Six years ago, a survey of Fortune 500 companies (published in ACM SIGMOD proceedings, 1983) conducted by two Ohio professors showed that the ER methodology ranked as the most popular methodology in data modeling and database design. Why? Because it is simple, easy to understand by noncomputer people, and theoretically sound. To illustrate, here are the major steps of the ER approach using the above example:

- *Develop an entity-relationship diagram (ERD).* This step identifies ER types and associated attributes and also the primary keys for each entity type.

An *entity* is a thing (e.g., a person or an automobile), a concept, an organization, or an event of interest to the organization doing the modeling. An *entity type* is a classification of entities satisfying certain criteria. A *relationship* is an interaction between entities. A *relationship type* is a classification of relationships based on certain criteria. Usually, nouns in English correspond to entities, while verbs correspond to relationships.

In the example in figures 1a and 1b, you can identify three entity types: DEPT, EMP, and PROJ. You can also identify two relationship types: HAS and WORK_FOR (note that relationship-type names are verbs). Figure 2 depicts an ERD in which rectangular boxes represent entity types and diamond-shaped boxes represent relationship types.

The next step is to identify the *cardinality* of the relationship types. The cardinality of HAS (between DEPT and

EMP) is 1:n (one-to-many); that means a department can have many employees, but each belongs to at most one department. The cardinality of WORK_FOR (between EMP and PROJ) is n:n (many-to-many). You then identify the properties (attributes) of each ER and express them graphically as circles (or ellipses). For example, each DEPT has attributes DEPT# and BUDGET. The primary key is indicated by a double circle. Note that there is an attribute called %TIME for relationship WORK_FOR.

- *Convert the ERD into conventional file and database structures.* There are rules for doing this. For example, you can convert the ERD in figure 2 into the relational structure with all the primary keys underlined.

```
DEPT(DEPT#, BUDGET)
EMP(SS#, NAME, AGE, DEPT#)
PROJECT( PROJ#, PNAME)
WORK_FOR(SS#, PROJ#, %TIME)
```

Simply speaking, each entity type is converted into a relation, and a relationship type is converted into a stand-alone relation or consolidated with another re-

lation, depending on the cardinality of the relationship.

If you are familiar with relational normalization theory, you can prove that these relations are in Third Normal Form. As you can see, all the primary keys of the relations are derived automatically, and DEPT# in EMP relation is a *foreign key* (i.e., the primary key of another relation—DEPT).

- *Develop application programs based on the file and database structures.* If you are using a relational DBMS, you can now write a System Query Language (SQL) program to express the question, Which departments have employees working on project X?

```
SELECT EMP.DEPT#
FROM EMP, WORK_FOR
WHERE (WORK_FOR.PROJ# = X)
AND(WORK_FOR.SS# = EMP.SS#)
```

This article shows how to design a relational database based on the ER approach. Similarly, you can design file structures and various other databases—from microcomputer-based DBMSes,

continued

a)						
Layout	SOC_SEC_NO	NAME	AGE	DEPT#	BUDGET	
Format	Char(9)	Char(20)	Int(2)	Int(3)	Int(9)	
b)						
Layout	SS#	EMP_NAME	AGE	PROJ#	NAME	%TIME
Format	Char(9)	Char(20)	Real(3.2)	Int(4)	Char(30)	Int(2)

Figure 1: (a) File format for the program to list employees in each department. (b) File format for the program to list projects for each employee.

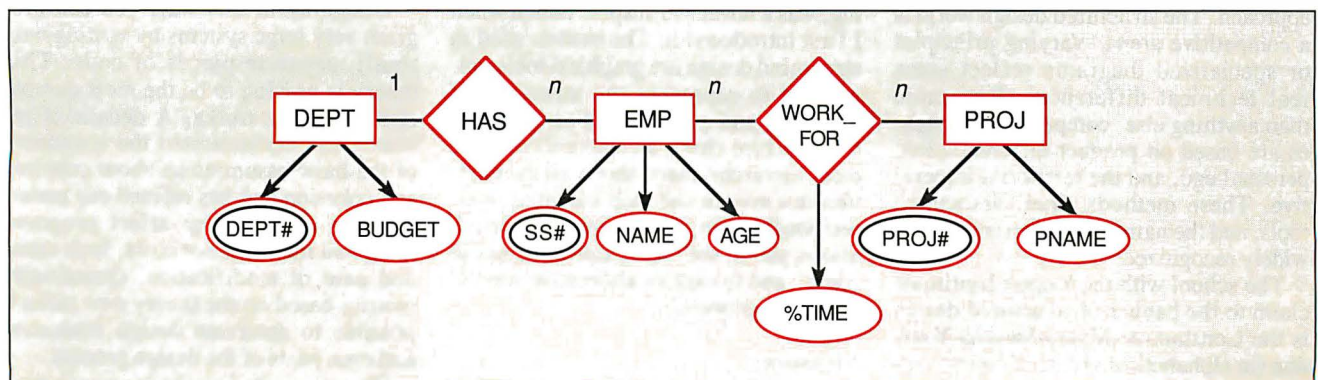

Figure 2: Entity-relationship diagram (ERD) for a database based on figure 1.

such as dBASE, to mainframe-based DBMSes, such as DB2 and IMS—based on the ER approach.

Future Trends

You have seen how to design a database and an application program based on the ER approach. The resultant database is sound and avoids such problems as data duplication and update anomalies. Commercial tools are available today to automate the ER approach.

The ER model can be used not only as a design tool but also as the underlying model for a DBMS. In the microcomputer and minicomputer range, Zanthé (Ottawa) has a product called ZIM. In the mainframe area, several computer vendors have ER-like DBMSes ready for

marketing. For example, Software AG has ADABAS/Entire, and Unisys has SIM as part of its InfoExec offering.

On another front, ANSI recently approved an Information Resource Dictionary Systems standard based on the ER model. In the near future, we'll see a flood of IRDS products as well as computer-aided software engineering tools based on the ER model.

BIBLIOGRAPHY

ANSI. *Standards on Information Resource Dictionary Systems*, 1988.

Chen, Peter P. "Entity-Relationship Model: Toward a Unified View of Data." *ACM Transaction on Database Systems*, vol. 1, no. 1.

Davis, C. G., S. Jajodia, P. Ng, and R.

Yeh, eds. *Entity-Relationship Approach to Software Engineering*. New York: North-Holland, 1983.

March, Sal, ed. *Entity-Relationship Approach*. New York: North-Holland, 1988.

Teorey, Toby, and James Fry. "An Extended Entity-Relationship Approach to Logical Database Design." *ACM Survey*, 1986.

Peter P. Chen is Foster Distinguished Chair professor at Louisiana State University and the founder of Chen & Associates, both in Baton Rouge, Louisiana. He received a Ph.D. in computer science/applied mathematics from Harvard University. He can be reached on BIX c/o "editors."

The Structured-Design Approach

Larry L. Constantine

The computer field likes big words. Why call something an *instance* when *instantiation* works just as well, even if it isn't in the dictionary? A software design *method* sounds like the sort of generic-brand thinking that anyone could work out over a long weekend. But a software design *methodology* sounds like an elaborate and well-thought-out concept, perhaps worth attending a seminar on by a major software guru, and certainly worth the price of a book. However, *methodology* actually means the study of methods, and *software methodology* is an ungrammatical use of the word.

Structured design is both a generic term for various systematic approaches to designing program structure and also a kind of brand name for one particular approach. The structured design world is a competitive arena. Varying principles or specialized diagrams reflect some real technical differences. But, more than anything else, competing approaches are based on product differentiation, personal ego, and the territorial imperative. These methods, their associated tools, and the names of the principals are widely recognized.

The school with the longest legitimate claim to the banner of structured design is the Constantine-Myers-Stevens-Yourdon (in alphabetical order, of course) approach that I originated in the late 1960s. It begins with a data-flow diagram (DFD) (often called a "bubble chart")

showing the transformational structure of an information-processing problem; then it derives a model of the modular structure of software that will solve that problem.

Models

Much is made of design methods, but structured design is really powered by a *troika* consisting of models, methods, and measures (see figure 1). The models make it possible to picture and play with the modular structure of software systems without actually having to program them first.

System-structure modeling, now accepted as essential to software engineering, was a novel and suspect notion when I first introduced it. The models used in structured design are graphical tools, annotated to represent the structure of problems and programs. For example, the structure chart, an elaboration of the older hierarchy chart, shows all the modules in a system and their essential interrelationships in one compact model. It allows you to see the "shape of things to come" and to explore alternative ways to organize software.

Measures

Structured design, unlike some other structured techniques and software engineering "methodologies," is grounded in

a body of underlying theory about what makes programs complicated to build right in the first place and difficult to change in the second. The practical embodiment of this theory takes the form of two measures—coupling and cohesion—that index the relative complexity or difficulty of various designs.

Simple programs are, simply put, made out of little pieces, each of which is easily thought of as a unit or a whole that is mostly independent of other pieces. Module cohesion is a measure of module "wholeness," and coupling measures interdependence. In other words, good designs that are easy to build and change are based on a bunch of modules, each of which is "cohesive," or well-glued together, and only loosely "coupled" to other modules.

Designing in this way, you can program very large systems by writing only small, separate pieces of code. This theory is proving to be the most durable element of the troika. A decade of research has demonstrated the soundness of the basic assumptions about coupling and cohesion and has refined our understanding of how they affect programming and maintenance costs, fault rates, and ease of modification. Quantitative metrics based on the theory now make it possible to automate design evaluation and even parts of the design process.

Object-oriented methods are emerging as major factors in software engineering, but even with these powerful new tech-

niques, the cohesion of actual modules that implement object classes and their coupling with other modules turn out to be important for building simple systems with truly reusable components. As a consequence, the original measures of coupling and cohesion have now been extended and adapted to evaluate the quality of so-called object class modules and abstract data types.

Methods

Methods is the weak third member of the structured design team, but the one that gets much of the attention. The methods of structured design include a loose collection of rules and some moderately systematic strategies for the step-by-step design of software. These strategies are based on specific kinds of software organization that have proved effective in practice. Among the most durable are the balanced system structure known as *transform-centered* organization and the event-oriented organization called *transaction-centered*. Distinct design methods are aimed at producing each variation on system organization.

You might outline an overall structured design method as follows:

1. Develop a nonprocedural (method-independent) statement of the system requirements, usually centered around a DFD.
2. Based on the structure of the problem, choose an appropriate software organizational model or combination.
3. Guided by the data flow and the chosen organizational model, decompose overall functions into subfunctions and compose primitive functions into higher-level functions until the complete requirements are satisfied.
4. Using various design rules and measures of coupling and cohesion, refine the design for increased modularity, extensibility, and likely reusability of modules.
5. Complete detailed designs as necessary for all modules.

The problem, of course, is that actually carrying out the modeling, evaluation, and refinement involved in structured design takes discipline and time, uses a lot of paper, and can wear out the erasers on every pencil in the office. Unaided by computer tools, many developers who use structured design have used it informally and unsystematically, while others have used its concepts to shape

their thinking without ever applying the formal models, measures, and methods.

Automating Methods

Computer-aided software engineering is not a replacement or substitute for systematic methods; it's the key that unlocks their full potential. With CASE tools, real structured design on problems of interesting size becomes truly practicable for the first time. The diagram editors of CASE systems assist in developing and refining complex graphical models. CASE tools with built-in knowledge of the models' meaning can check them for consistency and conformance with the established rules of structured design.

With intelligence about good designs incorporated into CASE tools, the computer can evaluate the quality of actual structured designs or even sketch out a rough initial design. At present, the most advanced CASE workbenches provide powerful support for existing software engineering methods; in the future, new structured methods are likely to be developed based on the use of quasi-intelligent CASE tools.

CASE systems can also reinforce or impose standards for software architectures and the diagrams that document them, but CASE vendors have yet to take on much responsibility for standardization. Most of the available tools and

workbenches are methodology-independent—meaning you can use them to do any brand of design, structured or unstructured, that you may choose.

This may be an acceptable level of flexibility, given the state of the science in “computer science,” but some of these tools have arbitrarily departed from what few standards and conventions do exist. It doesn't make sense for a system to use its own peculiar icon for an included module any more than to allow a CAD/CAM system for electrical engineers to use just any old shape to represent a transistor.

If we use computer-aided software engineering tools, and we call ourselves software engineers, perhaps it's time we acted more like engineers. ■

BIBLIOGRAPHY

- Stevens, W. P., G. J. Myers, and L. L. Constantine. “Structured Design.” *IBM Systems Journal*, vol. 13, no. 2, 1974.
- Yourdon, Edward, and Larry L. Constantine. *Structured Design*. Englewood Cliffs, NJ: Yourdon Press/Prentice-Hall, 1979.

Larry L. Constantine is a software methodologist in Acton, Massachusetts. He is a well-known author and speaker in the field of structured design and analysis. He can be reached on BIX c/o “editors.”

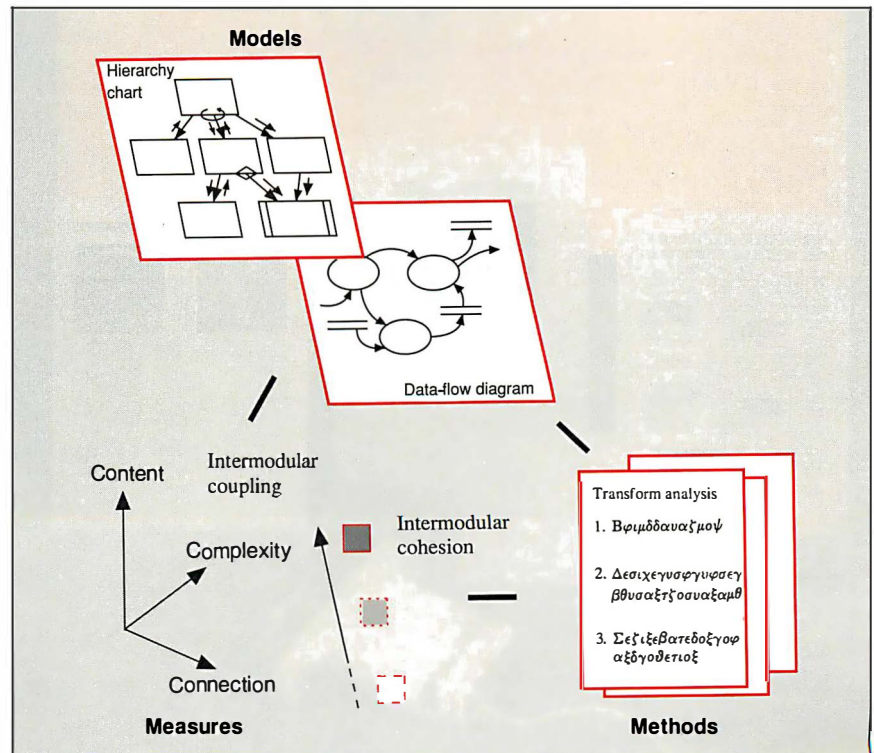

Figure 1: The troika of structured design: models, methods, and measures.

GIVE YOUR COMPUTER A BETTER IMAGE!

When it comes to hand scanners, **IMAGE IS EVERYTHING!** NISCAN's advanced image processing technology is well suited for desktop publishing, optical character recognition, and paint programs. All for under \$300.

FULLY FEATURED!

Pass NISCAN over any photograph, text or illustration and watch as a crisp, clear image appears instantly on your screen. Then employ any of NISCAN's advanced editing features to help transform the ordinary into the extraordinary.

NISCAN covers a full 4.2 inch path and has 6 software selectable dither patterns and 32 contrast levels. The NISCAN package comes complete with scanner, GEM scan software, half card and helpful users guide.

NISCAN IS COMPATIBLE!

NISCAN runs on IBM PC/XT/AT* and compatibles. Image files are easily used in most paint and publishing programs, including VENTURA PUBLISHER*, ALDUS PAGEMAKER* and PC PAINTBRUSH +*.

Call **1-800-245-SCAN** today and let us tell you about optional optical character recognition, image vectorization and image file conversion software.

For more information or the nearest NISCAN dealer, call **1-800-245-SCAN**.

NISCAN is made by NISCAN Incorporated, 1919 Old Denton Rd, #104, Carrollton, Texas 75006.

Product names preceding "*" are registered trademarks of their respective companies.

All images displayed are NISCAN output. Color has been added to some of the monochrome images.



NISCAN

image is everything



QUALITY IN... QUALITY OUT

No matter how well acquainted you are with making personal computing decisions—decisions that may involve hundreds of thousands of dollars—the value of those decisions is only as good as the value of your information. Without quality information—it's hard to make quality decisions.

BYTEweek, McGraw-Hill's new weekly newsletter for professionals in the personal computer industry, is devoted to giving you that quality information in a timely and compact one-stop news format. And BYTEweek interprets this news with in-depth commentary and analysis.

Subscribe to BYTEweek for quality information. Remember, quality in . . . quality out.

Take advantage of the special one-year charter subscription rate of \$395 (\$495 outside the U.S. and Canada)—a savings of \$100 off the regular rate. Your subscription includes 50 issues plus a free three-month subscription to BIX—a \$49 value.

Don't miss this opportunity! In the U.S., call BYTEweek's toll-free number: **1-800-258-5485**, in N.H. or outside the U.S., call: **1-603-924-9281**.

BYTEweek offers a *money-back guarantee* if you're not completely satisfied.

BYTEWEEK

News and Analysis for
Professionals in the Personal
Computing Industry
One Phoenix Mill Lane,
Peterborough, NH 03458

The CASE Experience

*CASE works. But do you need a tool, a toolkit, or a workbench?
And how do you begin?*

Carma McClure

Do you believe in software automation as the key to increasing productivity, controlling quality, and introducing predictability into the software process?

Touche-Ross does. It's betting its ability to build client applications with analyst-only teams on software automation.

Deere & Co. does. It believes that automation is the answer to productivity gains on the shop floor and should be the answer to needed productivity improvements in its MIS department as well.

So does DuPont. It's offering a money-back guarantee that its people can custom-build applications that meet user satisfaction and schedules with the aid of software automation.

These organizations first proclaimed their belief in software automation three years ago when they each reported that using computer-aided software engineering (CASE) technology had a positive effect on software productivity and quality. (See the text box "A CASE of Three" on page 236.) Today, their belief in software automation is as strong as ever. Because of successful experiences with CASE, they are using



more CASE tools to build all types of software systems and are even venturing into new business directions.

CASE technology is replacing paper and pencil with the computer to transform software development into an automated process. Simply defined, CASE is software automation. The basic idea underlying CASE is to provide a set of well-integrated, labor-saving tools that auto-

mate software development and maintenance work.

CASE is a combination of software tools and structured software development methodologies. The tools automate the software process, and the methodologies define the process to be automated. CASE technology focuses on the productivity of business, real-time, and scientific-software systems developers. With the use of personal computers and workstations, LANs, and CASE tools, software developers can work from a highly responsive, dedicated environment to develop and maintain software systems.

CASE Tools

CASE tools are a new breed of graphics-oriented, micro-computer-based software tools (see figures 1 through 4). As the notion of CASE

evolved over the last five years, the definition of a CASE tool broadened from meaning simple systems analysis and documentation tools to include full-function tools providing automated support for the entire software life-cycle process. The broadest definition of a CASE tool is any software tool that provides automated assistance for software

continued

A CASE of Three

Touche-Ross

In the summer of 1986, Touche-Ross of Milwaukee, Wisconsin, was an avid user of Excelerator, the CASE toolkit from Index Technology. Touche-Ross prided itself on being an early believer in CASE and was one of the first users of Excelerator. During the previous two years, it had equipped its teams of systems analysts, who had been trained in the Yourdon school of structured methodologies, with over 100 copies of Excelerator, POSE from Computer Systems Advisers, Visible Analyst from Visible Systems, and DesignAid from Nastec.

These IBM PC-based CASE toolkits were used in the creation of requirements specifications for information systems, such as order entry, inventory control, and a bidding system. The Touche-Ross experiences with analyst/design toolkits whetted its appetite for more automated assistance of the software process and for more CASE tools to automate additional software tasks. Touche-Ross recently added the Information Engineering Facility (IEF), the CASE workbench from Texas Instruments, to its set of CASE tools.

Touche-Ross found that accomplishing individual software tasks with the aid of CASE tools is easy, but even with them, the whole software process is still horrible if you don't understand what to do with the tools. Because a software development methodology is a good guide to what exactly is to be done when building a software system, Touche-Ross has trained its systems analysts in a full life-cycle methodology: information engineering. Training for the IEF workbench and the information engi-

neering methodology requires three to four weeks at a cost of \$10,000 per analyst.

Expanding its horizon for more software automation, Touche-Ross is now using CASE tools to support strategic systems planning, system requirements specification, systems design, and code generation tasks. Touche-Ross is also expanding its belief in what software automation can do in practice today. It believes that with the use of CASE tools, its systems analysts can custom-build application systems for clients.

The interesting point here is that there are no programmers at Touche-Ross. Both software development and software maintenance will be done without programmers. The company believes that the CASE technology is now mature enough to support this tremendous and daring change. According to Touche-Ross, the payoff from using CASE will come from its ability to produce higher-quality software products in the same amount of time and to greatly reduce software maintenance.

Touche-Ross's advice to newcomers to the CASE technology is to start now and start slowly with a pilot project.

Deere & Co.

When searching for a better way to manage data, the data administration group at Deere & Co. in Moline, Illinois, discovered CASE tools. Deere has been using CASE since 1985 when it installed 10 copies of the IBM PC-based Information Engineering Workbench from KnowledgeWare. Deere's systems analysts used the IEW to support requirements analysis and the data analysis tasks performed during the first two

software development phases. In 1986, Deere viewed CASE tools as the means whereby software developers could do more work in less time, do a better job of specifying system requirements, and reduce the software maintenance effort.

During the past two years, both Deere's experience with CASE and the CASE tools themselves have matured. Deere believes that CASE is helping it do a better job of developing software systems. However, it's impossible to quantify how much better because Deere, like many other organizations, has no base against which to measure. Deere believes that even a 1 percent productivity improvement means a lot of savings. Also, with CASE, Deere is taking systems knowledge out of the heads of software developers and putting it into the CASE tool repository to create an infrastructure of reusable systems information. In the long term, this will lead to the greatest productivity gains.

When recently asked for an update on its use of CASE, Deere & Co. said it's basically more of the same. Deere currently has installed 39 copies of the IEW as well as APS, the COBOL code generator from Sage Software. While approximately 30 analysts are now using CASE tools, Deere plans to raise this to 125 analysts over the next three years.

Deere's CASE implementation strategy is to "go slowly and easily." It began by defining what its software needs were and then finding the software development methodology and CASE tools to address those needs. Deere started small with an initial CASE investment of \$25,000. Starting small lessened the need for formal cost justification of CASE tools. Also, since a belief in automation was already per-

development, maintenance, or project management activities.

But to qualify as a bona fide CASE tool today, a software tool must exhibit additional traits. CASE tools use powerful graphics to describe and document software systems and to enhance the user interface. CASE tools are integrated, making it easy to pass data from tool to tool. And CASE tools capture software system information in a computerized repository where it can be shared among software developers, used as the basis for automating software production, and re-used in future software systems.

In the mid-1980s, there were only a handful of CASE tools offered in the marketplace. Today, over 100 vendors sell CASE tools worldwide. While the 1988 worldwide CASE market reached about \$250 million, a rapid growth rate of 30 percent to 45 percent per year is predicted to drive the CASE market size to \$1 billion by the early 1990s.

Selecting a Tool

With so many different CASE tools from which to choose, selecting the right one for the job requires some consideration. No one tool can provide complete auto-

mated support for the development and maintenance of every type of software system. Different CASE tools run on different types of hardware, specialize in the development or maintenance of different types of software systems, and automate different software tasks.

What the tool does is the fundamental selection consideration. CASE tool categories explain and differentiate the functions performed by different types of CASE tools. The two basic categories are toolkits and workbenches.

A CASE toolkit is a collection of integrated software tools that provide auto-

vative throughout this manufacturing company, Deere management needed little convincing that software automation was the answer to software productivity and quality problems.

Today, Deere & Co. uses CASE tools to free its software developers to be more creative by automating many mundane, repetitive software tasks, such as documentation and code generation. Although CASE tools primarily are used by and benefit professional software developers, Deere hopes that eventually end users will be able to access the CASE tool repository where company data and business operating rules are being stored.

Deere & Co. offers some good advice for CASE users. First, although it knows of several deficiencies in CASE tools today, Deere said that this is no reason to wait to use the CASE technology. In addition, no organization can absorb all of CASE at once. Therefore, it is best to get in and gradually get experience with CASE.

Second, Deere & Co. advises that management "press hard" to ensure that CASE tools are actually used. An important consideration in implementing CASE is a plan for educating users in CASE tool and software development methodology. Finally, Deere suggests that an organization begin by first defining its needs and the benefits it is seeking. Then, it should look for the technology that can address those needs and deliver those benefits.

DuPont

Like Touche-Ross, DuPont of Wilmington, Delaware, entered the business of custom-application system development

in part because of CASE. The other element that has made this business more possible is RIPP, DuPont's proprietary software-prototyping technique. In 1988, the Information Engineering Associates (IEA) unit at DuPont began offering custom-application development services for Digital Equipment Corp.'s VAX-based information systems for customers internal and external to DuPont. IEA uses the CASE workbench CorVision from Cortex to support its RIPP prototyping approach to software development.

DuPont's experience with CASE tools and prototyping began in 1985 with the development of the Bulk Continuous-Fiber Tracking System for the Camden-based Textile Fibers department at DuPont. A 6-to-1 productivity increase over estimated performance proved the project a notable success and opened the door for subsequent CASE/RIPP development projects at DuPont.

Over the next 15 months in nine other development projects using the CASE/RIPP approach, DuPont measured success in terms of a \$2 million savings. By 1988, over 50 DuPont departments used the CASE approach. Productivity increases ranged from 3-to-1 to 5-to-1 over manual development methods using COBOL or FORTRAN. Application-maintenance costs decreased by as much as 75 percent.

DuPont's advice to CASE technology users underscores the requirement of end-user involvement as a critical factor in ensuring project success. According to DuPont's IEA unit, if key end users are not willing to commit adequate time to the systems development effort, then don't do the project; the risk of failure is too great.

design, and implementation; share a set of common assumptions about the software process model or methodology being automated; use a common repository containing all technical and project management information needed to build and support a software system; automatically pass software system information from process step to process step; share a common user interface; and share a common tool interface. CASE workbenches offer automated support across the software development process to deliver a documented, executable software system.

Other technical considerations for

choosing CASE tools are the hardware platforms on which they run; the type of target system, such as a mainframe-based COBOL information system or an embedded FORTRAN real-time system, that the tools help build and maintain; and the types of structured methodologies, structured diagrams, and error checking that the tools automate. Another important technical consideration is the capability of the CASE tool repository to store and manage various types of software system information. The text box "A CASE Tool Evaluation Checklist" on page 240 can guide you in tool selection.

Nontechnical considerations center on the ability of the vendor to develop and support CASE tools, the training and support needed to introduce them into an organization, and the organization's attitude toward software automation.

CASE Toolkits

Since a CASE toolkit specializes in automating particular software tasks, choosing one involves matching the tool to the tasks to be automated. Also, CASE tool users frequently use several different toolkits as well as outside tools, such as fourth-generation languages, dictionaries, and DBMSes, during the software process. When this is the intent, then how well the toolkits and outside tools can be interfaced to work together is another important tool-selection consideration.

- *Analysis and design.* These toolkits are used to create a software system specification and design. They include screen and report painting, simulation, prototyping, and error-checking functions. Many analysis and design toolkits run on the IBM PC and compatibles; are used to create information systems; and support widely used structured methodologies, such as DeMarco or Gane/Sarson structured analysis, Yourdon or Jackson structured design, and Martin information engineering.

Examples include The Developer from ASYST Technologies, Design Generator from Computer Sciences, POSE from Computer Systems Advisers, ProKit*Workbench from McDonnell-Douglas, Excelerator from Index Technology, DesignAid from Nastec, Design Machine from Optima, MicroStep from Sycorp International, Structured Architect from Meta Systems, vsDesigner from Visual Software, and Analyst/Designer Toolkit from Yourdon. (Contact information for the products discussed in this

continued

ated assistance for one type of software task; use a common repository for all technical and project management information needed to build and support a software system; share a common user interface; and share a common tool interface. CASE toolkits focus on the support of one phase of software development or one type of software task, such as systems analysis, database design, or program implementation.

A CASE workbench, on the other hand, is a collection of integrated software tools that provide automated assistance for software systems analysis, de-

article is provided in the resource guide "A CASE Workshop" on page 246.)

Other analysis and design toolkits used in the development of information systems, such as AnaTool from Advanced Logical Software, run on the Macintosh, while still others, such as CA-Universe/Prototype from Computer

Associates International and CasePac from On-Line Software International, run on IBM mainframe computers.

CASE analysis and design toolkits that support the development of real-time or embedded systems, real-time structured methodologies (such as Ward/Mellor and Hatley), Ada program development, and

DOD2167 documentation generation frequently run on 32-bit engineering workstations, such as Sun, Apollo, Hewlett-Packard, or DEC VAXstations. Examples include Teamwork from Cadre Technologies, Software Through Pictures from Interactive Development Environments, StateMate from i-Logix, Analyst/RT from Mentor Graphics, System Architect from Popkin Software & Systems, CardTools from Ready Systems, and SDT from Telelogic Europe.

- *Database and file design.* These toolkits provide automated assistance for the design of databases and files by performing functions such as logical data modeling, conversion to third normal form, and generation of database schemas and program-code file descriptions. Examples of database and file-design toolkits that run on IBM PCs and compatibles include IDEF/Leverage from D. Appleton, Chen Toolkit from Chen & Associates, IDMS/Architect from Cullinet Software, 4Front from Deloitte, Haskins & Sells, Auto-Mate Plus from LBMS, and CASE*Designer from Oracle.

- *Programming.* These toolkits support the programming and testing steps in software development. Programming toolkits that provide configuration management functions on the IBM PC or DEC VAX include P-Source and P-Tools from Phoenix Technologies and Poly-Make from Polytron. CoFac from Coding Factory and COBOL 2/Workbench from Micro Focus provide support for the creation of COBOL programs and run on the IBM PC.

Other programming toolkits provide automatic code generation from program-design specification information. These toolkits, called code generators, automatically produce a fully documented, executable program. They offer screen and report painting, prototyping, custom-logic handling, testing and debugging, and code, database, and documentation generation. COBOL code generators that run on an IBM PC and IBM mainframe or DEC VAX computers include DECASE from DEC, NETRON/CAP from Netron, Telon from Pansophic Systems, APS from Sage Software, and Transform from Transform Logic.

- *Maintenance and reengineering.* This type of toolkit aims the CASE technology at existing software systems rather than at the creation of new systems. Tools in the maintenance and reengineering toolkit, such as documenters, program analyzers, restructuring en-

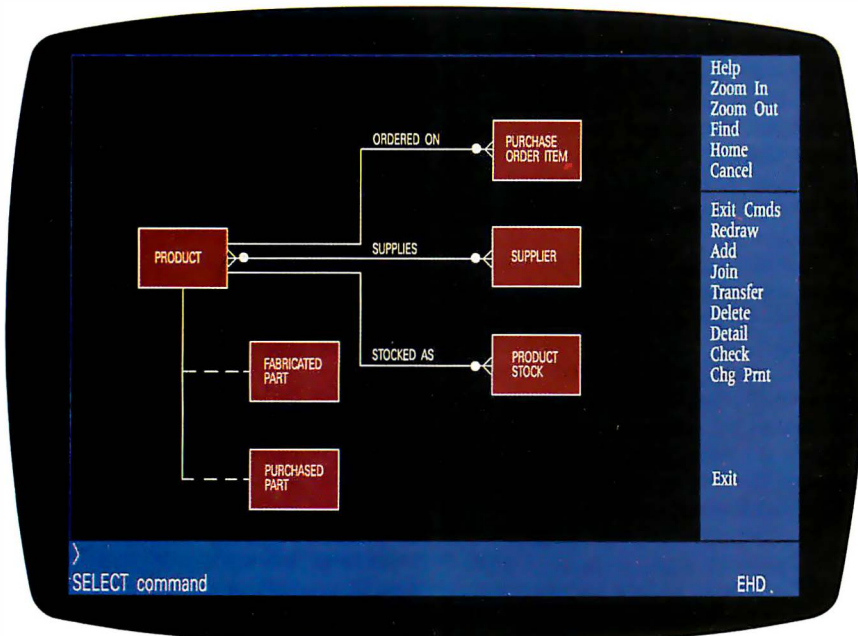

Figure 1: The IBM PC screen view of an entity-relationship diagram drawn with the Information Engineering Facility from Texas Instruments.

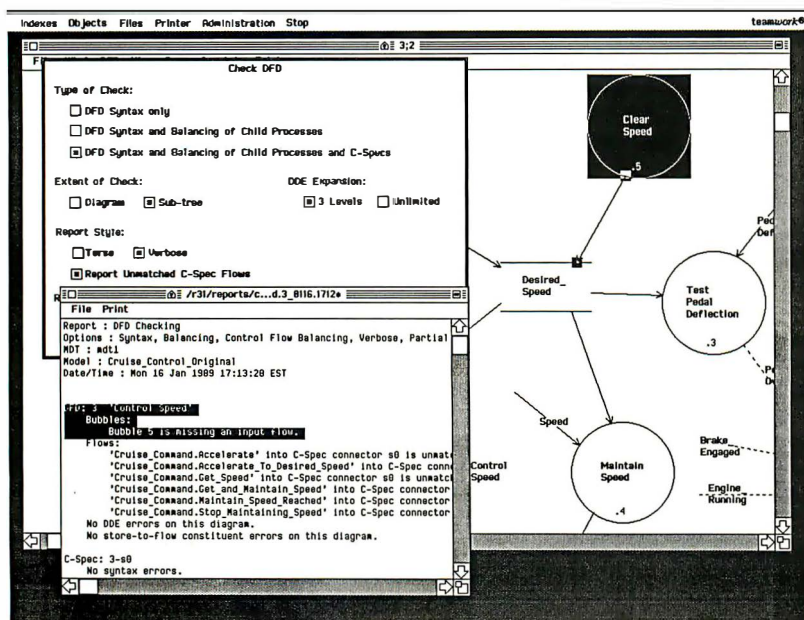

Figure 2: Teamwork from Cadre Technologies reports syntax, balancing, and missing information errors in data-flow and control-flow diagrams.

gines, and reverse-engineering tools, automate a variety of program maintenance tasks and have the potential to improve the maintainability of billions of lines of existing code.

Running on IBM mainframes, IBM PCs, and Honeywell, Unisys, or Wang computers, toolkits such as Adpac CASE Tools from Adpac, Scan/COBOL and SuperStructure from Computer Data Systems, Inspector and Recoder from Language Technology, PathVu and Retrofit from Peat Marwick Advanced Technology, and Via/Insight and Via/SmarTest from ViaSoft provide maintenance support for existing COBOL programs. The Bachman Re-Engineering Product Set from Bachman Information Systems provides reverse-engineering support for IMS, IDMS, and DB2 databases and runs on the IBM PS/2s.

- **Framework.** This kind of toolkit provides a platform for CASE tool integration, creation, and customization. Multi/CAM from AGS Management Systems, Life Cycle Productivity System from American Management Systems, Software BackPlane from Atherton Technology, and Sylva Foundry from Cadware are examples of framework toolkits running on the Sun, Apollo, Hewlett-Packard, DEC VAX, IBM PC, and mainframe computers.

- **Project management.** These toolkits support the planning, controlling, managing, and reporting functions needed for software development and maintenance projects. One example of an IBM PC-based project management toolkit is Project Workbench from Applied Business Technology.

CASE Workbenches

Selecting a CASE workbench involves matching hardware, development methodologies, and target systems that the workbench supports to the CASE user's development style and target-system requirements. For example, IBM PC- and mainframe-based workbenches, such as Foundation from Andersen Consulting, Information Engineering Workbench from KnowledgeWare, PACBase from CGI Systems, CorVision from Cortex, Manager Family from Manager Software Products, Maestro from Softlab, and Information Engineering Facility from Texas Instruments are used to develop information systems that run on PCs or mainframes.

For the development of real-time and embedded systems in languages such as Ada, Pascal, FORTRAN, and C, work-

benches such as SuperCASE from Advanced Technology International, Auto-Code from Integrated Systems, ProMod from ProMod, and EPOS from SPS Software Products & Services are used.

State of the Practice

The promise of CASE is to increase software productivity and improve software

quality. For Touche-Ross, Deere & Co., and DuPont, CASE is fulfilling its promise. Many other organizations, such as Amoco, First National Bank of Chicago, First Boston, Union Pacific, Lincoln National Corp., and American International Group, are also believers in and seasoned users of CASE. Their valuable

continued

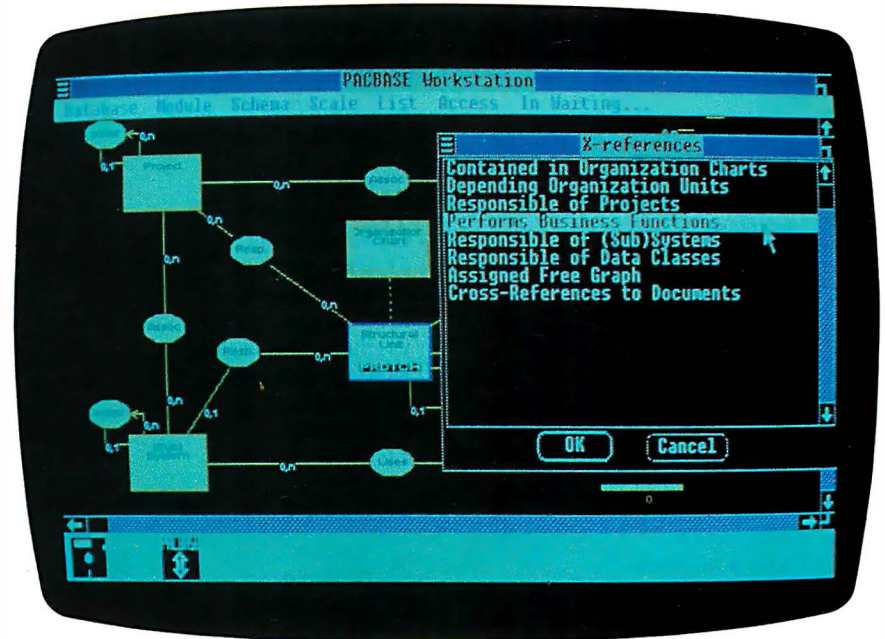

Figure 3: The IBM PC screen shows PACDesign, part of the PACBase workbench from CGI Systems, which is used during the program-design process.

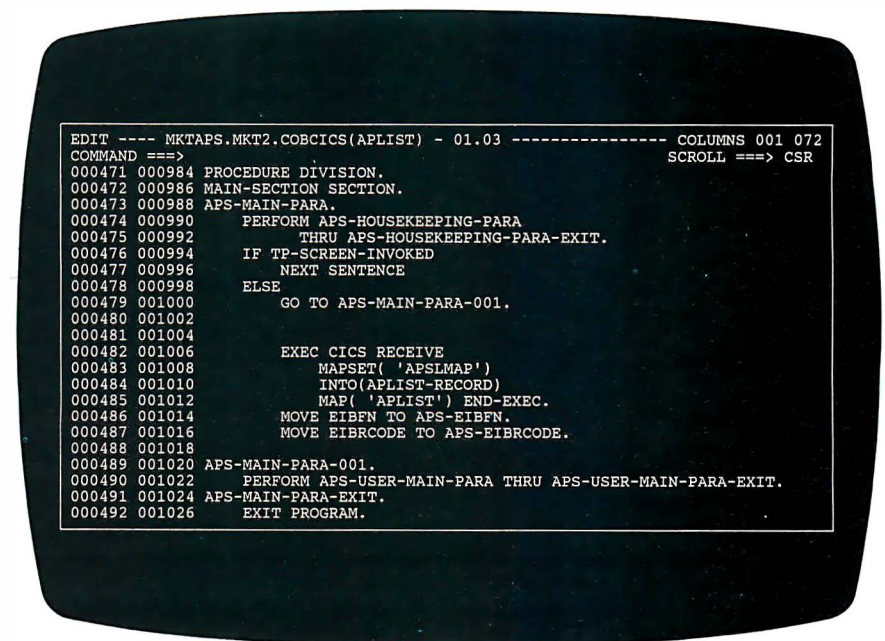

Figure 4: This COBOL code was automatically generated by APS, the CASE COBOL code generator from Sage Software.

A CASE Tool Evaluation Checklist

Use this checklist as a guide through the maze of CASE tool options

General information

- Vendor name
- Product name
- Date introduced
- Number of copies sold
- Price

Hardware platform

- IBM PC and compatibles
- Macintosh
- Digital Equipment Corp.
- Unisys
- Honeywell
- Wang
- Apollo
- Sun
- Hewlett-Packard
- Other

Category

- CASE toolkit
- CASE workbench

Type of toolkit

- Planning
- Analysis
- Design
- Database design
- Real-time design
- Code generator
- Programming
- Maintenance
- Framework
- Project management

Graphics

- Color
- Mouse
- Windows

Error checking

- Syntax
- Consistency
- Completeness
- Requirements traceability
- Quality assurance

Diagramming support

- Data flow
- Control flow
- Decision table/matrix
- Hierarchical tree structure
- Structure chart
- Action
- Warnier/Orr
- State transition
- Pseudocode
- Screen layout
- Dialogue flow
- Report layout
- Data structure
- Entity relationship
- Logical records
- Booch
- Petri nets
- Other

Methodology support

- Yourdon
- DeMarco
- Gane/Sarson
- Bachman
- Chen
- Martin
- Merise
- Orr
- Jackson
- Ward/Mellor
- Hatley
- Object-oriented
- SADT
- Stradis
- Method-1
- LSDM
- Other

Other requirements

- _____
- _____
- _____

CASE repository

- Host-based
- PC-based
- DBMS architecture
- Reports
- Change control
- Audit trail
- Version control
- Download
- Logical partitioning
- Consolidation

Prototyping support

- Screen painter
- Report painter
- Functional model
- Simulation

Code generation

- Skeleton program
- Complete program
- Language
- On-line program
- Batch program

Reengineering support

- Static analyzer
- Redocumentation
- Restructure
- Reverse engineering
- Dynamic analyzer
- Converter

Life-cycle support

- Planning
- Analysis
- Design
- Implementation
- Maintenance
- Project management

Target system

- On-line
- Batch
- Transaction processing
- Real-time
- Embedded

experiences and insights can guide others in wisely selecting CASE tools and successfully implementing the CASE technology. The following summarizes their experiences and consensus

about the current state-of-the-practice of CASE technology.

• *Profile of a user.* First, regardless of which tools they use, the primary users

of CASE tools today are professional software developers (e.g., business analysts, systems analysts, programmers), not the end users. This is not meant to

continued

Virtual Memory for DOS!

MicroWay is your best source for the software and hardware you need to get true 32 bit performance from your 386. These include 32-bit tools, such as NDP Fortran and C, and the 32-bit applications that were developed with them (see last paragraph). These products run in protected mode under Unix, Xenix, or Phar Lap extended MS-DOS.

Starting with release 1.4VM, NDP Fortran and C not only access 4 gigabytes of memory, but run with Phar Lap's new VMM extension which provides 386 protected mode virtual memory. Now you can run a program with a 30 MB array on a 2 MB system simply by having 30 MB of free space on your hard disk.

MicroWay also offers transputer based parallel processing boards and languages that run in an XT, AT, or 386. Each of the T800 RISC processors on these boards packs the power

Dr. Robert Atwell, leading defense scientist, calculates that NDP Fortran-386 is saving him \$12,000 per month in rentals of VAX hardware and software while doubling his productivity!

Fred Ziegler of Aspen Tech in Cambridge, Mass. reports, "I ported 900,000 lines of Fortran source in two weeks without a single problem!" AspenTech's Chemical Modeling System is in use on mainframes worldwide and is probably the largest application to ever run on an Intel processor.

Dr. Jerry Ginsberg of Georgia Tech reports, "My problems run a factor of six faster using NDP Fortran-386 on an mW1167 equipped 386/20 than they do on my MicroVAX II."

of a 20 MHz 386/1167. Our best selling board, the Quadputer2™, has four T800s and boasts 40 MIPS/6 megaflops of processor throughput.

MicroWay manufactures Weitek 1167 and 3167 coprocessor cards that run with the 80386. Both cards include an 80387 socket. The 1167 is 2 to 4 times faster than the 80387. The 3167 runs 30% faster than the 1167 in double precision. The key to achieving this speed increase is our NDP Fortran or C and the new 32-bit applications that offer Weitek support. Either processor provides a dramatic increase in throughput for graphics intensive applications. These include VersaCad and Hoops 3D graphics, ANVIL 5000 CAD/CAM, SRAC and Swanson Analysis finite element packages, Mathematica and a host of other packages that were recently ported to the 386 using our NDP Fortran and NDP C. Please call (508) 746-7341 for more information.

32-Bit Compilers and Tools

NDP Fortran-386™ and NDP C-386™ Compilers generate globally optimized, mainframe quality code. Both run in 386 protected mode under Unix, Xenix or Phar Lap extended MS-DOS. The memory model employed uses 2 segments, each of which can be up to 4 gigabytes. They generate code for the 80287, 80387, mW3167 or mW1167. Both include high speed EGA graphics extensions written in C that perform BASIC-like screen operations.

- **NDP Fortran-386™** Full implementation of FORTRAN-77 with Berkeley 4.2 and Fortran-66 extensions. \$595
- **NDP Fortran-386/VM** \$695
- **NDP Fortran-386/UNIX** \$795
- **NDP C-386™** Full implementation of AT&T's PCC with MS and ANSI extensions. . . . \$595
- **NDP C-386/VM** \$695
- **NDP C-386/UNIX** \$795

Phar Lap 386/VMM extensions are supported by the VM releases of NDP Fortran and C. Virtual memory is used automatically by the compilers and the code they generate. This makes it possible to compile and run programs as large as the free space on your hard disk.

Phar Lap Virtual Memory Manager . . \$295
Phar Lap Development Tools \$495

NDP Windows™ — NDP Windows includes 80 functions that let you create, store, and recall menus and windows. It works with NDP C-386 and drives all the popular graphics adapters Library: \$125, C Source: \$250

NDP Plot™ — Calcomp compatible plot package that is callable from NDP Fortran. It includes drivers for popular plotters and printers. Works with CGA, MDA, EGA and VGA . . . \$325

NDP/FFT™ — Includes 40 fast running, hand coded algorithms for single and double dimensioned FFTs which take advantage of the 32-bit addressing of the 386 or your hard disk. Callable from NDP Fortran with mW1167 and 80387 support \$250
387FFT for 16-bit compilers \$250

NDP to HALO '88 Graphics Interface — This module enables you to call graphics routines in HALO '88 from NDP Fortran or C. \$100

MicroWay® 80386 Support (508) 746-7341

Parallel Processing

Videoputer™

The highest performance graphics card on the market. Uses a T800 and TI 34010 in conjunction with a 130 MHz BrookTree DAC. The board comes with one meg of system RAM, one meg of video RAM and a library of graphics primitives. It runs standalone or in conjunction with a transputer network and drives 32 and 64 KHz analog monitors \$4995

Monoputer2™

The world's most popular PC transputer development product now extends the memory available for developing transputer applications from 2 to 16 megabytes. The board features a DMA bus interface for fast I/O.

Monoputer2 with T414 (0 MB) \$995
Monoputer2 with T800 (0 MB) \$1495

Quadputer2™

This board for the AT or 386 can be purchased with 2, 3 or 4 transputers and 1 or 4 megabytes of memory per transputer. Two or more Quadputers can be linked together to build networks of up to 100 or more transputers providing mainframe power **from \$3495**

Transputer Compilers and Applications

These Parallel languages are designed for use with Monoputer2 and Quadputer2.

Logical Systems Parallel C \$595
3L Parallel C or 3L Parallel Fortran . . \$895
Microfield - Finite element analysis . . \$1600
ParaSoft: Parallel Environment . . . \$500
Performance Monitor \$500
C Source Level Debugger \$500
T800/NAG™ (See NDP/NAG) \$2750

387BASIC™ — Our 16-bit MS compatible compiler introduces numeric register variables to produce the fastest running 80x87 code on the market \$249

Weitek-Based Coprocessor Boards

mW1167™ and mW3167™ coprocessor boards are built at MicroWay using Weitek components. Each includes an 80387 socket.
mW1167-16 \$895
mW1167-20 \$1095
mW1167 Microchannel-16/20 CALL
3167-20 \$995
3167-25 \$1295
mW3167/80387 Board \$150

Intel Coprocessors and RAM

8087 \$84
8087-2 \$120
80287-8 \$195
80287-10 \$220
80C287A (CMOS) \$280
80387-16 \$350
80387-16SX \$310
80387-20 \$400
80387-25 \$500
287Turbo-12 (for AT compatibles) . . . \$350
RAMpak™ - 1 meg 32-bit memory module for Compaq system memory board . . \$650
256K 100ns DRAM CALL
256K SIMMS CALL
1 MB SIMMS CALL
 (All of our Intel coprocessors include 87Test.)

Multi-User Accelerators

MicroWay's **AT8™** and **AT16™** intelligent serial controllers run 8 to 16 terminals under Unix or Xenix without bogging down your AT, 80386 or PS/2 PC. **AT8:** \$895 **AT16:** \$1295

32-Bit Applications

PSTAT-386 — Popular mainframe statistics package. Full version was ported \$1495
NDP/NAG™ — Features a library of 268 engineering and scientific numerical algorithms. Callable from NDP Fortran \$895
 Call for our list of new 32-bit applications.

12 MHz PC Accelerators

FastCACHE-286 12 MHz \$299
SuperCACHE-286 12 MHz \$399
FastCACHE-286 9 MHz \$199

MicroWay

World Leader in PC Numerics

Corporate Headquarters: P.O. Box 79, Kingston, MA 02364 USA (508) 746-7341
 32 High St., Kingston-Upon-Thames, U.K., 01-541-5466
 USA FAX 508-746-4678 Australia 02-439-8400 Germany 069-75-1428

suggest that end users are being shut out of the software development process. On the contrary, end-user involvement in the form of interviews, reviews, and use of software prototype models is critical to software project success.

Users point out that although CASE tools are user-friendly, the quantity of system information that they must enter into the tool demands too much of their time. Moreover, using a CASE tool requires a level of software development knowledge that is beyond that of many end users. Even for the professional software developer, substantial training and experience are needed to effectively use CASE.

CASE tool training is not as significant in terms of time and cost as methodology training, which can be as much as three times as expensive. The amount of training required depends on whether developers have already been trained in the methodology to be supported and automated. Furthermore, attitude can have just as much influence on the effective use of CASE as training. Users agree that enthusiasm is a must to ensure successful results from CASE.

• *Management support.* It is extremely difficult to cost-justify bringing CASE into an organization, because most companies have no measures for software productivity or quality and no historical software-project data. While the desire is to do "better," there is no universally agreed-on way to quantify what "better" means.

For many CASE users, the only way to get management commitment is to convince management to give CASE a try on blind faith. Also, many users note that the real payoff doesn't occur during systems development but later, during system maintenance and with the leverage from reusing data models and other system information stored in the CASE repository. Some users report that the maintenance of systems developed with CASE requires only 20 percent of the effort needed to maintain those systems developed with traditional techniques.

• *Changing software development.* Opinions are divided on whether CASE changes software development and maintenance. Those who think CASE doesn't significantly change software develop-

ment are using CASE tools to automate a methodology they have used previously. The software process remains basically the same but is streamlined by automating some labor-intensive tasks.

On the other side, users who say CASE dramatically changes the way they develop systems are bringing in a new software development methodology along with CASE tools. For example, they may have moved from a process-driven development approach to a data-driven approach, or from a traditional waterfall life-cycle model to prototyping.

According to one CASE user, the nature of maintenance work has changed. Instead of maintaining code, users are now maintaining design specifications and, in particular, a data model. Keeping the data model up-to-date has become a top-priority maintenance task. One trend appears to be toward adopting data-driven methods and prototyping techniques as standard information-systems development strategies.

• *Single or multiple CASE vendors.* Users are also split in their strategy to

continued

PCYACC™
Version 2.0

**PROFESSIONAL
LANGUAGE DEVELOPMENT TOOLKIT**

Professional Version \$395.00 — Personal Version \$139.00

Includes "Drop In" Language Engines for SQL, dBASE, POSTSCRIPT, HYPERTALK, SMALLTALK-80, C++, C, PASCAL, and PROLOG.

PCYACC Version 2.0 is a complete Language Development Environment that generates ANSI C source code from input Language Description Grammars for building Assemblers, Compilers, Interpreters, Browsers, Page Description Languages, Language Translators, Syntax Directed Editors, and Query languages.

Complete grammars, Lexical Analyzers, and Symbol Table Management for ANSI C, K&R C, ISO Pascal, dBASE III/Plus and IV, SQL, C++, Smalltalk-80, APPLE HyperTalk, C&M Prolog, YACC, LEX, and POSTSCRIPT are included. OS/2 and MAC versions are available.

Example application sources are provided to be used as skeletons for new programs. Examples include a desktop calculator, an Infix to Postfix Translator, a dBASE and SQL Syntax analyzer, an implementation of the PIC[ture] language, and a C++ to C translator.

- Lexical Analyzer Generator ABRAXAS PCLEX is included
- Quick Syntax analysis option
- Optional Abstract Syntax Tree
- Advanced Error recovery Support Provided
- Manual "Compiler Construction with PCS" included
- All examples include FULL SOURCE
- 30 day money back guarantee
- No charge for shipping anywhere in the world

To order, please call
1-800-347-5214



**ABRAXAS™
SOFTWARE, INC.**

7033 SW Macadam Ave. Portland, OR 97219 USA

TEL (503) 244-5253 · FAX (503) 244-8375
AppleLink D2205 · MCI ABRAXAS

Just Say: Name Brands

At Just 7% Over Wholesale*

QUADRAM

JT/FAX
\$249*

JT/FAX has features such as pull-down windows, multiple scheduling and Broadcast FAX.

Runs unattended. Input: scanner or word processor. Output: dot matrix or laser printer. Group III FAX compatible.
External Stand-Alone Version \$349*

LOGITECH

AWARD-WINNING MICE

Logitech Serial Mouse \$79*
Logitech IBM BUS Mouse 89*
Logitech Hi-Res. Mouse 99*

ASK ABOUT
OCR/ASCII
SOFTWARE

**LOGITECH
HAND
SCANNER**



\$199*

W/ Paint Show Plus Software

CALL ABOUT OUR FULL PAGE SCANNERS!

CITIZEN

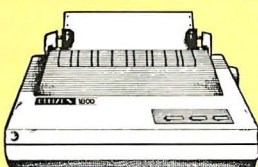

180D
\$189*

• Epson Compatible • 180 CPS/9 Pin
Citizen 120, 120 CPS/9 Pin \$159*
MSP 50, 300 CPS/9 Pin 299*
Tribute 224, 24 Pin/360 DPI Laser Quality! 399*

US ROBOTICS

HST *Clearly the most popular high speed modem on the market.*
\$569*



HAYES COMPATIBLE

• At 300-2400 BAUD • LEV 5 MNP FOR 17,400 BPS
• US Made • 2 Year Warranty • Toll Free Support
New HST V.32 Standard CALL
USR 2400 Baud Hayes Compatible Now \$129*

AWARD-WINNING SYSTEMS

**30 MB HARD DRIVE SYSTEM
286 / AT**

• 80286 Intel Processor • 30 MB Hard Disk
• 80287 Co-Processor Slot • IBM & OS2 Compat. System
• VGA/EGA Graphics Card • Choice of Optional Monitor

\$995*



65 MB 386/TOWER CASE SYSTEM

COMPARE:

• 80386 Intel CPU
• 80387 Co-Processor Slot
• 1 MB Expandable to 10 MB
• 65 MB Hard Disk Drive
• UNIX and OS/2 Compatible

\$1995*

Now Only

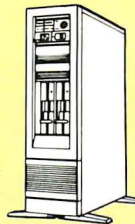

MINISCRIBE



**HARD
DISKS**

EASY TO INSTALL KITS

20 MB With Controller \$279*
40 MB With Controller 369*
110 MB With Hi RLL Controller 799*

TOSHIBA

All New!

**3100E
LAPTOP**

12 Mhz/20 MB

\$2895*

PORTABLE HEADQUARTERS!



PC/WORKS

**MULTI-LINE
VOICE/MAIL**

PCX Telemarketing System

For a live demonstration of PCX, please call: 805/654-0721.

From \$269

**4800 BAUD
HAYES
COMPATIBLE MODEM**

USING MICROCOM LEV 5 MNP SOFTWARE INCLUDED

Save Over \$200 NOW!

• Supports 300-1200-2400 Baud TOO!
• Auto Dial • Auto Answer

\$99*

2 YEAR WARRANTY

DLX: MULTI-USER



**ON-LINE DATABASE SYSTEM
WITH ELECTRONIC MAIL**

• Runs Directly Under MS-DOS
• Supports Modems or Terminals
• On-Screen Order Entry and More!
• Easy to Install • Very User Friendly

\$395

ALL *PRICES SHOWN ARE WHOLESAL AND REFLECT AN ADDITIONAL 3% CASH DISCOUNT. THE ON-LINE STORE'S WHOLESAL + 7% PURCHASERS PAY JUST 7% ABOVE THE WHOLESAL PRICE, PLUS SHIPPING AND HANDLING. Minimum shipping: \$5 per order. International orders: call for rates. Prices subject to change. Products subject to availability and may be private label versions. WE ALSO SERVE LARGE CORPORATE ORDERS: call for information. This ad supersedes all previous.

CALL NOW! 24 HOUR ORDER LINE:

805/650-0188



BBS 805/650-0193

FAX 805/650-0195

CUSTOMER SERVICE 805/650-0188



3037 Golf Course Dr., Ventura, CA 93003

ONLINE STORE

Your Data Communications System Specialist

Some Things Never Change

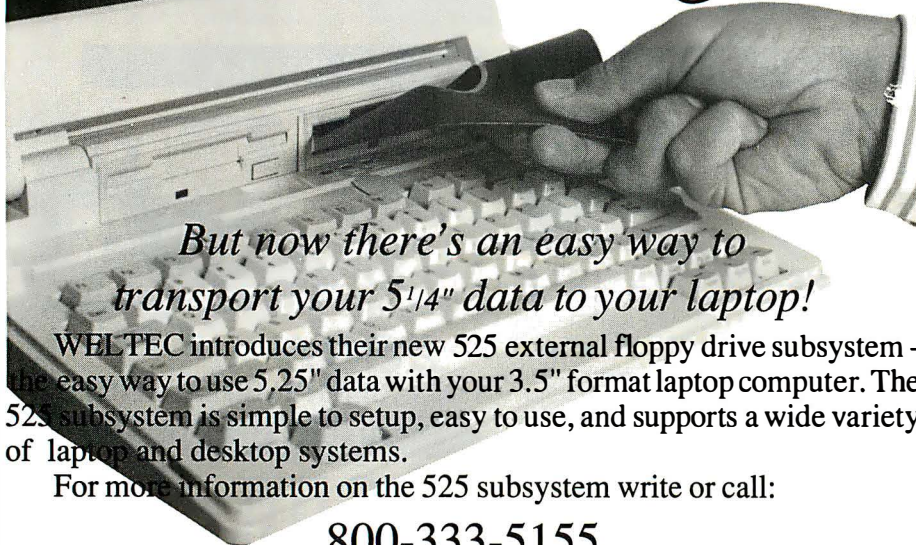

But now there's an easy way to transport your 5 1/4" data to your laptop!

WELTEC introduces their new 525 external floppy drive subsystem - the easy way to use 5.25" data with your 3.5" format laptop computer. The 525 subsystem is simple to setup, easy to use, and supports a wide variety of laptop and desktop systems.

For more information on the 525 subsystem write or call:

800-333-5155



WELTEC digital, inc.

17981 Sky Park Circle, Suite M, Irvine, CA 92714
Phone: 714-250-1959 • Telex: 3728057 • FAX: 714-250-1964

See us at Spring COMDEX
Booth #3557

Definitions on disk

Choice Words gives you instant access to 80,000 dictionary definitions plus more than 470,000 synonyms from Merriam-Webster—the English language authority.

The dictionary contains definitions, usage notes and hyphenation points. The thesaurus contains synonyms, meanings for each synonym group and properly inflects all responses.

Choice Words works with over 35 word processors on IBM-PC compatibles running MS-DOS and is available on either 5 1/4" or 3 1/2" disks. Your system must contain a hard disk and at least 100K of free memory.

Whether you're writing, reading, or simply want to explore the English language in a new and exciting way, Choice Words is for you.

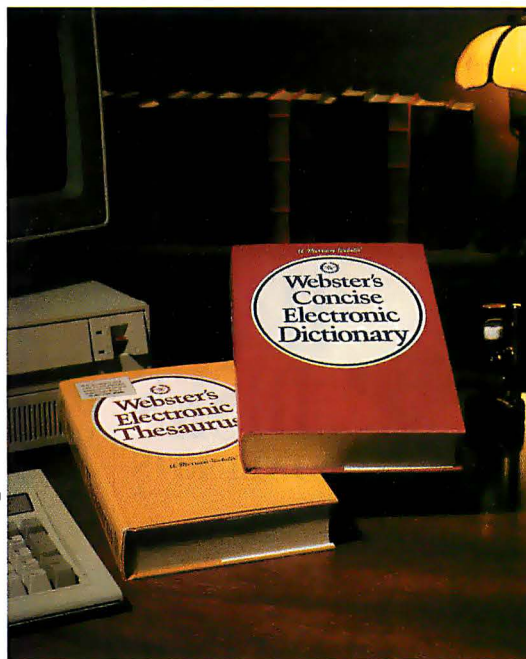

CHOICE WORDS™

\$99

1 9 8 8



BYTE
AWARDS OF
DISTINCTION

See your dealer, Or order directly by calling 1-800-323-0023, (305) 566-3511 in FL) Dealers: Order Choice Words from Micro-D

PROXIMITY

Intelligence You Can Use™

3511 N.E. 22nd Avenue
Fort Lauderdale, FL 33308

use tools provided by only one vendor or multiple CASE product vendors. Users dedicated to a single-vendor approach believe a single vendor can provide a higher level of tool integration.

On the other hand, users who mix and match tools from multiple vendors say they want the best tool for each task and that different vendors excel in different areas. And since these users develop systems for different target environments, different tools are often necessary.

Users are confident that as industry standards emerge, CASE tool interfaces will be improved. At the very least, most CASE users experiment with multiple CASE tools regardless of whether they intend to follow a single- or multiple-vendor strategy.

Start Now

Organizations considering CASE should start now and start slowly. Start now because you need some experience with CASE before you can derive significant benefits from it. The learning curve can be steep, especially when you start by introducing both new CASE tools and new methodologies. Starting slowly gives you the opportunity to experiment with new tools and/or new methodologies before embracing CASE on a wide scale.

Most CASE experiences originate in various types of R&D groups whose charter is to find better ways to develop software systems. Many organizations are interested primarily in increasing productivity, while others are searching for ways to get organized, especially from the data perspective, and some are simply researching future technologies. However, regardless of what they were expecting from CASE, those organizations that reported achieving their goals all began their CASE experience with two major advantages: They were advocates of change, and they had management support.

If you are new to CASE, think about what your organization hopes to achieve and then select the tools that can help achieve those goals. Begin the CASE experience with a pilot project in which there is no pressure, no immediate productivity goal, and lots of management support. And, by all means, begin now. ■

Carma McClure is vice president of Extended Intelligence in Chicago and has a Ph.D. in computer science from the Illinois Institute of Technology. A leading authority on CASE, her most recent book is CASE Is Software Automation (Prentice-Hall, 1988). She can be reached on BIX c/o "editors."

The ultimate in sound...
The ultimate in savings...



100586

100715. R.E.M.: Green Orange Crush, Pop Song 89, etc. (Warner Bros.)



200596

100602. Elton John: Reg Strikes Back • Elton's 22nd gold album! (MCA)

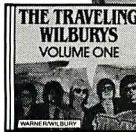

100711

200478. Metallica: And Justice For All • #1 Speed metal band! (Elektra)
223559. The Beach Boys: Endless Summer • 21 timeless hits! (Capitol)
100532. Diane Schuur: Talkin' 'Bout You • Cry Me A River, etc. (GRP)



100603

105392. Pops In Space John Williams & The Boston Pops. Music from Star Wars, The Empire Strikes Back, more. (Philips DIGITAL)



115436

100604. Heifetz: The Decca Masters, Vol. 1 Golliwog's Cakewalk, Clair de lune, many more. (MCA)



100707

100035. Robert Palmer: Heavy Nova • Simply irresistible. More Than Ever, etc. (EMI)

153582. Tracy Chapman Fast Car, Talkin' 'Bout A Revolution, etc. (Elektra)

164165. Bobby McFerrin: Simple Pleasures • Don't Worry Be Happy, etc. (EMI)

244006. Simon & Garfunkel: The Concert In Central Park • All-time classics! (Warner Bros.)

125179. Tchaikovsky, 1812 Overture; Romeo And Juliet; Nutcracker Suite Chicago Symp. Orch./Solti. (London DIGITAL)

100459. Cocktail (Original Soundtrack) • (Elektra)

123385. The Best Of Eric Clapton: Time Pieces (Polydor)

100579. K. T. Oslin: This Woman • Hold Me, Money, title song, more. (RCA)

100470. Vangelis: Direct New Age Meditations, The Motion Of Stars, The Will Of The Wind, etc. (Arista)

153983. Charlie Parker: Compact Jazz • Now's The Time, Night And Day. (Verve)

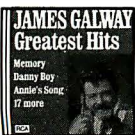

173233



100714

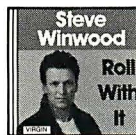

154633

START NOW WITH 4 COMPACT DISCS!

Yes, pick any 4 compact discs shown here! You need buy just one selection at regular Club prices (usually \$14.98 - \$15.98)...and take up to one full year to do it. Then you can choose another CD free as a bonus. That's 6 compact discs for the price of 1 and there's nothing more to buy...ever! (Shipping & handling added to each shipment.)

HOW THE CLUB OPERATES

You select from hundreds of exciting compact discs described in the Club's magazine and mailed to you approximately every 3 weeks (19 times a year). Each issue highlights a Featured Selection in your preferred music category, plus alternate selections. If you'd like the Featured Selection, do nothing. It will be sent to you automatically. If you'd prefer an alternate selection, or none at all, just return the card enclosed with each issue of your magazine by the date specified on the card. You will have at least 10 days to decide, or you may return your Featured Selection at our expense for full credit. Cancel your membership at any time after completing your membership agreement, simply by writing to us.

FREE 10-DAY TRIAL

Listen to your 4 introductory selections for a full 10 days. If not satisfied, return them with no further obligation. You send no money now, so complete the coupon and mail it today.

BMG Compact Disc Club
6550 E. 30th St., Indianapolis, IN 46219-1194.

CD692



154135. The Best Of Steely Dan: Decade 14 hits. (MCA)

104871. Supertramp: Classics (14 Greatest Hits) • The Logical Song, Give A Little Bit, more. (A&M)

144578. The Judds: Greatest Hits • (RCA)

115356. Pinnock: Vivaldi, The 4 Seasons • Simon Standage, violin, etc. (Archiv DIGITAL)

114780. Cinderella: Long Cold Winter • Gypsy Road, Don't Know What You Got, more. (Mercury)



182522

270106. An Evening With Louis Armstrong • (GNP Crescendo)

262889. Virgil Fox: The Digital Fox • Organ music by Bach, others. (Bainbridge DIGITAL)



115311

209468. Perlman: Brahms, Violin Sonatas (Angel DIGITAL)

120768. 20 Great Love Songs Of The 50s & 60s, Vol. 1 • (Laurie)

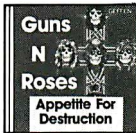

170348

153740. Genesis: Invisible Touch • (Atlantic)

163579. Andrés Segovia Plays Rodrigo, Ponce & Torroba • Fantasia para un Gentilhomme, Concierto del Sur, Castles Of Spain. (MCA)

100679. Steve Earle: Copperhead Road • (UNI)

134267. Marriner: Mozart, Overtures • Academy of St. Martin. (Angel DIGITAL)

153606. INXS: Kick • Need You Tonight, Devil Inside, etc. (Atlantic)

100517. Phil Collins: Buster/Soundtrack • Groovy Kind of Love, Two Hearts, etc. (Atlantic)



100927

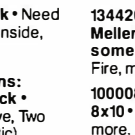

115457

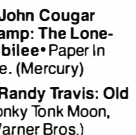

100713

134420. John Cougar Mellencamp: The Lonesome Jubilee • Paper In Fire, more. (Mercury)

100008. Randy Travis: Old 8x10 • Honky Tonk Moon, more. (Warner Bros.)

GET 6 COMPACT DISCS FOR THE PRICE OF 1

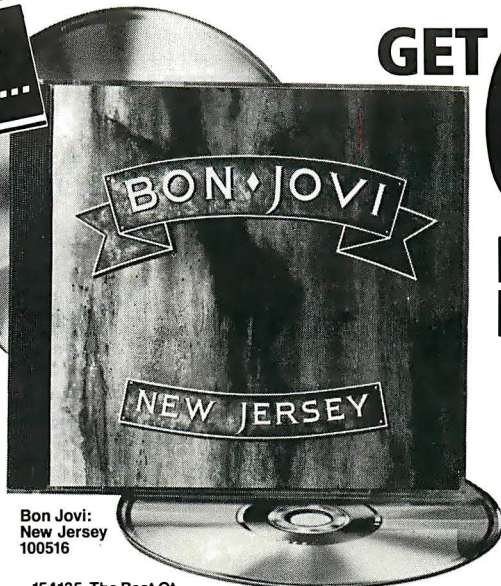

Bon Jovi: New Jersey 100516

...with nothing more to buy ever!

SAVE 50%

INSTANT HALF-PRICE BONUS PLAN

Unlike other clubs, you get 50%-off Bonus Savings with every CD you buy at regular Club prices, effective with your first full-price purchase!

YOUR SAVINGS START HERE

Mail to: BMG Compact Disc Club
P.O. Box 91412/Indianapolis, IN 46291

YES, please accept my membership in the BMG Compact Disc Club and send me the four Compact Discs I've indicated here, billing me for just shipping and handling under the terms of this ad. I need buy just 1 CD at regular Club prices during the next year — after which I can choose a FREE bonus CD! That's 6 for the price of 1...with nothing more to buy ever! (Shipping & handling is added to each shipment.)

RUSH ME THESE 4 CDs (Indicate by number):

D D D D

I am most interested in the musical category checked here—but I may always feel free to choose from any (check one only):

1 EASY LISTENING (Instrumental/Vocal Moods)
2 COUNTRY 3 HARD ROCK
4 POP/ROCK 5 CLASSICAL

MR. MRS. MISS

First Name Initial Last Name (PLEASE PRINT)
Address Apt.

City State Zip

Telephone () Area Code

Signature YDTAG (BU)

Limited to new members, continental USA only. Current CD Club members not eligible for this offer. One membership per family. We reserve the right to request additional information or reject any application. Local taxes, if any, will be added.

A CASE Workshop

Compiled by Carma McClure

Adpac CASE Tools
Adpac Corp.
340 Brannan St.
San Francisco, CA 94107
(415) 974-6699
Inquiry 983.

Analyst/Designer Toolkit
Yourdon, Inc.
1501 Broadway
New York, NY 10036
(212) 391-2828
Inquiry 984.

Analyst/RT Designer Auditor
Mentor Graphics Corp.
8500 Southwest Creekside Place
Beaverton, OR 97005
(503) 626-7000
Inquiry 985.

AnaTool
Advanced Logical Software
9903 Santa Monica Blvd.
Beverly Hills, CA 90212
(213) 653-5786
Inquiry 986.

APS
Sage Software, Inc.
3200 Tower Oaks Blvd.
Rockville, MD 20852
(301) 230-3200
Inquiry 987.

AutoCode
Integrated Systems, Inc.
2500 Mission College Blvd.
Santa Clara, CA 95054
(408) 980-1500
Inquiry 988.

Auto-Mate Plus
LBMS, Inc.
2900 North Loop W, Suite 800
Houston, TX 77092
(713) 682-8530
Inquiry 989.

Bachman Re-Engineering Product Set
Bachman Information Systems
Four Cambridge Center
Cambridge, MA 02142
(617) 354-1414
Inquiry 990.

CA-Universe/Prototype
Computer Associates International, Inc.
711 Stewart Ave.
Garden City, NY 11530
(516) 227-3300
Inquiry 991.

CardTools
Ready Systems Corp.
470 Potrero Ave.
P.O. Box 60217
Sunnyvale, CA 94086
(408) 736-2600
Inquiry 992.

CASE*Designer CASE*Dictionary
Oracle Corp.
20 Davis Dr.
Belmont, CA 94002
(800) 345-3267
Inquiry 993.

CasePac
On-Line Software International
2 Executive Dr.
Ft. Lee Executive Park
Ft. Lee, NJ 07024
(201) 592-0009
Inquiry 994.

Chen Toolkit
Chen & Associates, Inc.
4884 Constitution Ave.
Baton Rouge, LA 70808
(504) 928-5765
Inquiry 995.

COBOL/2 Workbench
Micro Focus, Inc.
2465 East Bayshore Rd.
Palo Alto, CA 94303
(415) 856-4161
Inquiry 996.

CoFac
Coding Factory
45 Knightsbridge Rd.
Piscataway, NJ 08854
(201) 981-0100
Inquiry 997.

CorVision
Cortex Corp.
138 Technology Dr.
Waltham, MA 02154
(617) 894-7000
Inquiry 998.

IDEF/Leverage
D. Appleton Co.
1334 Park View Ave., Suite 220
Manhattan Beach, CA 90266
(213) 546-7575
Inquiry 999.

DECASE
Digital Equipment Corp.
DECdirect
Continental Blvd.
Merrimack, NH 03054
(800) 344-4825
Inquiry 1000.

DesignAid RTTrace
Nastec Corp.
24681 Northwestern Hwy.
Southfield, MI 48075
(313) 353-3300
Inquiry 1001.

Design Generator
Computer Sciences Corp.
3160 Fairview Park Dr.
Falls Church, VA 22042
(703) 876-1000
Inquiry 1002.

Design Machine
Optima, Inc.
1300 Woodfield Rd., Suite 400
Schaumburg, IL 60173
(312) 240-1888
Inquiry 1003.

EPOS
SPS Software Products & Services, Inc.
14 East 38th St., 14th Floor
New York, NY 10016
(212) 686-3790
Inquiry 1004.

Excellerator Excellerator/RTS
Index Technology Corp.
One Main St.
Cambridge, MA 02142
(617) 494-8200
Inquiry 1005.

Foundation
Andersen Consulting
33 West Monroe St.
Chicago, IL 60603
(312) 507-5161
Inquiry 1006.

IDMS/Architect
Cullinet Software, Inc.
400 Blue Hill Dr.
Westwood, MA 02090
(617) 329-7700
Inquiry 1007.

Information Engineering Facility
Texas Instruments
P.O. Box 655621 MS 8474
Dallas, TX 75265
(214) 575-4404
Inquiry 1008.

Information Engineering Workbench
KnowledgeWare, Inc.
3340 Peachtree Rd., NE
Atlanta, GA 30026
(404) 231-8575
Inquiry 1009.

Inspector Recorder
Language Technology, Inc.
27 Congress St.
Salem, MA 01970
(508) 741-1507
Inquiry 1010.

Life Cycle Productivity System
American Management Systems, Inc.
1777 North Kent St.
Arlington, VA 22209
(703) 841-6060
Inquiry 1011.

Maestro
Softlab, Inc.
188 The Embarcadero
Bayside Plaza, Suite 750
San Francisco, CA 94105
(415) 957-9175
Inquiry 1012.

Manager Family
Manager Software Products, Inc.
131 Hartwell Ave.
Lexington, MA 02173
(617) 863-5800
Inquiry 1013.

Meta Systems Toolset Structured Architect
Meta Systems, Ltd.
315 East Eisenhower Pkwy.
Ann Arbor, MI 48108
(313) 663-6027
Inquiry 1014.

MicroStep
Syscorp International
9420 Research Blvd., Suite 200
Austin, TX 78759
(512) 338-0591
Inquiry 1015.

Multi/CAM
AGS Management Systems, Inc.
880 First Ave.
King of Prussia, PA 19406
(215) 265-1550
Inquiry 1016.

NETRON/CAP
Netron, Inc.
99 St. Regis Crescent N
Downsview, Ontario
Canada M3J 1Y9
(416) 636-8333
Inquiry 1017.

P-Source P-Tools
Phoenix Technologies, Ltd.
846 University Ave.
Norwood, MA 02062
(617) 551-4000
Inquiry 1018.

PACBase PACBench PACDesign
CGI Systems, Inc.
1 Blue Hill Plaza
Pearl River, NY 10965
(914) 735-5030
Inquiry 1019.

PathVu Retrofit
Peat Marwick Advanced Technology
303 East Wacker Dr.
Chicago, IL 60601
(312) 938-5352
Inquiry 1020.

POSE
Computer Systems Advisers
50 Tice Blvd.
Woodcliff Lake, NJ 07675
(201) 391-6500
Inquiry 858.

Project Workbench
Applied Business Technology Corp.
361 Broadway
New York, NY 10013
(212) 219-8945
Inquiry 859.

ProKit*Workbench
McDonnell-Douglas
P.O. Box 516
Dept. L 515, MS 2812301
St. Louis, MO 63166
(314) 232-5715
Inquiry 860.

ProMod
ProMod, Inc.
23685 Birtcher Dr.
El Toro, CA 92630
(714) 855-3046
Inquiry 861.

PVCS (Polytron Version Control System)
PolyMake
Polytron Corp.
1700 Northwest 167th Place
Beaverton, OR 97006
(503) 645-1150
Inquiry 862.

Scan/COBOL SuperStructure
Computer Data Systems, Inc.
1 Curie Court
Rockville, MD 20850
(202) 921-7000
Inquiry 863.

SDT
Telelogic Europe
33 Boulevard de la Cambre
B-1050 Brussels
Belgium
011-32-2-647-3670
Inquiry 864.

Software BackPlane
Atherton Technology
1333 Bordeaux Dr.
Sunnyvale, CA 94089
(408) 734-9822
Inquiry 865.

Software Through Pictures
Interactive Development Environments
595 Market St., 12th Floor
San Francisco, CA 94105
(415) 543-0900
Inquiry 866.

StateMate
i-Logix
22 Third Ave.
Burlington, MA 01803
(617) 272-8090
Inquiry 867.

SuperCASE
Advanced Technology International, Inc.
350 Fifth Ave.
New York, NY 10118
(212) 947-4755
Inquiry 868.

Sylva Foundry
Cadware
50 Fitch St.
New Haven, CT 06515
(203) 397-1853
Inquiry 869.

System Architect
Popkin Software & Systems
111 Prospect St., Suite 505
Stamford, CT 06901
(203) 323-3434
Inquiry 870.

Teamwork
Cadre Technologies
222 Richmond St.
Providence, RI 02903
(401) 351-5950
Inquiry 871.

Telon
Pansophic Systems, Inc.
2400 Cabot Dr.
Lisle, IL 60532
(312) 572-6000
Inquiry 872.

The Developer
ASYST Technologies, Inc.
One Naperville Plaza
Naperville, IL 60540
(800) 361-3673
Inquiry 873.

Transform
Transform Logic Corp.
8502 East Via de Ventura
Scottsdale, AZ 85258
(602) 948-2600
Inquiry 874.

Via/Insight Via/SmarTest
ViaSoft, Inc.
3033 North 44th St., Suite 280
Phoenix, AZ 85018
(602) 952-0050
Inquiry 875.

Visible Analyst
Visible Systems Corp.
950 Winter St.
Waltham, MA 02154
(617) 969-4100
Inquiry 876.

vsDesigner
Visual Software, Inc.
3945 Freedom Circle, Suite 540
Santa Clara, CA 95054
(408) 988-7575
Inquiry 877.

4Front
Deloitte, Haskins & Sells
200 East Randolph Dr.
Chicago, IL 60601
(312) 856-8168
Inquiry 878.

*By popular demand, we've extended
this program to April 30, 1989.*

FREE* SIVA 386 SYSTEM

*with the purchase of \$3295++
of software or \$4995++ of
hardware.*

Standard 386 Features:

- 32-bit Intel 80386-16 CPU.
- 1MB of 32-bit RAM on board. System expandable to 16MB.
- 8/16/20 MHz Keyboard selectable.
- ST-251-1 Seagate 40MB Formatted 28 ms high speed, with ultra high speed Controller 1:1 interleave.
- 1.2MB High Capacity Floppy Drive.
- Super deluxe heavy duty tower case with 6 half-height drive openings.
- High-resolution 12" Non-Glare Amber Display. Tilt and Swivel base, Hercules-compatible Adapter.
- 101 Key Enhanced Keyboard, Pleasant "Tactile/Click" Feel.
- 80287/387 Math-Coprocessors optional.
- Fully compatible with virtually all XT/AT and 386 software.

Upgrades for your FREE 386 System:

- VGA Color Upgrade — add only \$495.
- 20 MHz CPU Upgrade — add only \$195.
- Call for all other options and upgrades.

Choose Your Hardware

*A hardware purchase of \$4995 or more is required
to receive the SIVA 386 System FREE.*

- | | |
|---|--------|
| • QMS PS 810 Postscript Laser Printer | \$5495 |
| • CDC WREN IV 300MB SCSI Hard drive with Controller | \$2595 |
| • CDC WREN III 155MB SCSI Hard drive with Controller | \$1795 |
| • CDC WREN II 86MB ST506 Hard drive with HD/FD Controller | \$ 895 |
| • Eight Port RS232 Intelligent Card with Xenix Driver | \$ 995 |
| • 32-Bit 8MB Memory Expansion Board | \$2997 |
| • Intel 80387 — 16 Coprocessor | \$ 495 |

Software

- | | |
|---|--------|
| • Complete SCO Xenix System (including Operating System, Developing System and Text Processing System for 80386-based System) | \$1595 |
| • SCO Lyrinx System | \$ 595 |
| • SCO Professional | \$ 895 |
| • SCO Integra | \$1295 |
| • SCO Foxbase Plus | \$ 995 |
| • SCO VP/IX (integrated DOS environment — two users) | \$ 495 |
| • Language & Development Tools | CALL |
| • Networking & Communication Packages | CALL |

A software purchase of \$3295 or more is required to receive your FREE SIVA 386 System. Mix and match to meet your needs!

Ask about our Professional Services:

- Data Processing and Network Consulting
- Application Development and Training
- System Administration
- Hardware and Software Installation & Support

1-800-252-4212

VNS America Corp.

Suite 270, 910 Boston Post Road
Marlboro, Massachusetts 01752 U.S.A.
In Massachusetts 508-481-3726
FAX: 508-481-2218

All prices subject to change without notice.

Call For
Spectra Demo Unit, Diskette
Sales Tools and Special Pricing

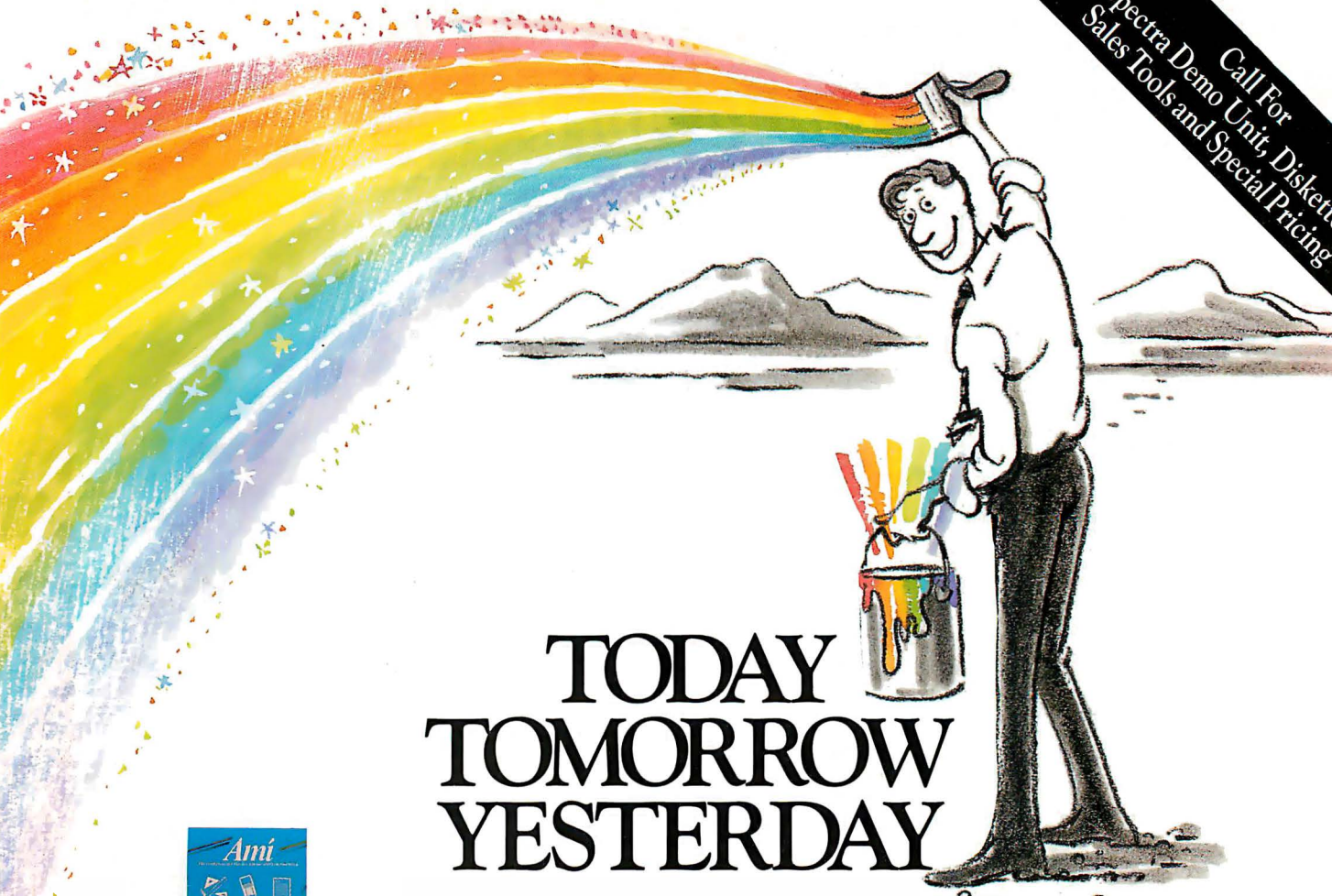

TODAY TOMORROW YESTERDAY

Today, you need VGA. Or maybe Extended VGA. We at Quadram believe you deserve more.

1024 x 768

Why settle for mere VGA? Or even Extended VGA with 256 colors at 800 x 600? QuadVGA Spectra gives you sixteen colors at the new graphics standard of tomorrow, 1024 x 768. And QuadVGA Spectra has the flexibility and power to enhance both 8-bit machines and 286/386 systems.

TranScan™

Our TranScan technology automatically adapts scan frequencies to make the most of your variable scan monitor as well as take advantage of the full family of PS/2 monitors.

Compatibility

Quadram was in the graphics business back when screens were monochrome. And we have provided our customers with a solid product in every mode that has evolved since. In fact, our QuadEGA+ and ProSync led the color revolution and are still popular boards. We understand graphics.

Naturally, QuadVGA Spectra is register-level compatible with all accepted modes from Extended VGA down to MDA. That means you can use yesterday's software as well as today's and tomorrow's.

Call Us

To find out where you can buy QuadVGA Spectra, call us at (404) 564-5566. And find out how to enjoy tomorrow, today.

Quadram: One Quad Way, Norcross, Georgia 30093
Fax: (404) 564-5528. In Canada, call (416) 821-7600.
Mexico: (011-5283) 35-0901. France: (011) 33-14-722-5820.
England: 011-44-753-34421.
Germany: (011)-49-6102-17095.

Trademark/Owner: Quadram, the Quadram logo, QuadEGA+, QuadEGA ProSync, QuadVGA Spectra/Quadram, PS/2/IBM, Ami, Samna Corporation, Mac, Apple Computer, Inc.



QuadVGA S P E C T R A

Bundled With Ami™

The award-winning graphical word processing software for DOS users with Mac Envy.

\$199 Value

Free Through 5-30-89



We Don't Make Computers.
We Make Them Better.

Spring 1989

BYTE

Bonus Graphics Section

Graphics

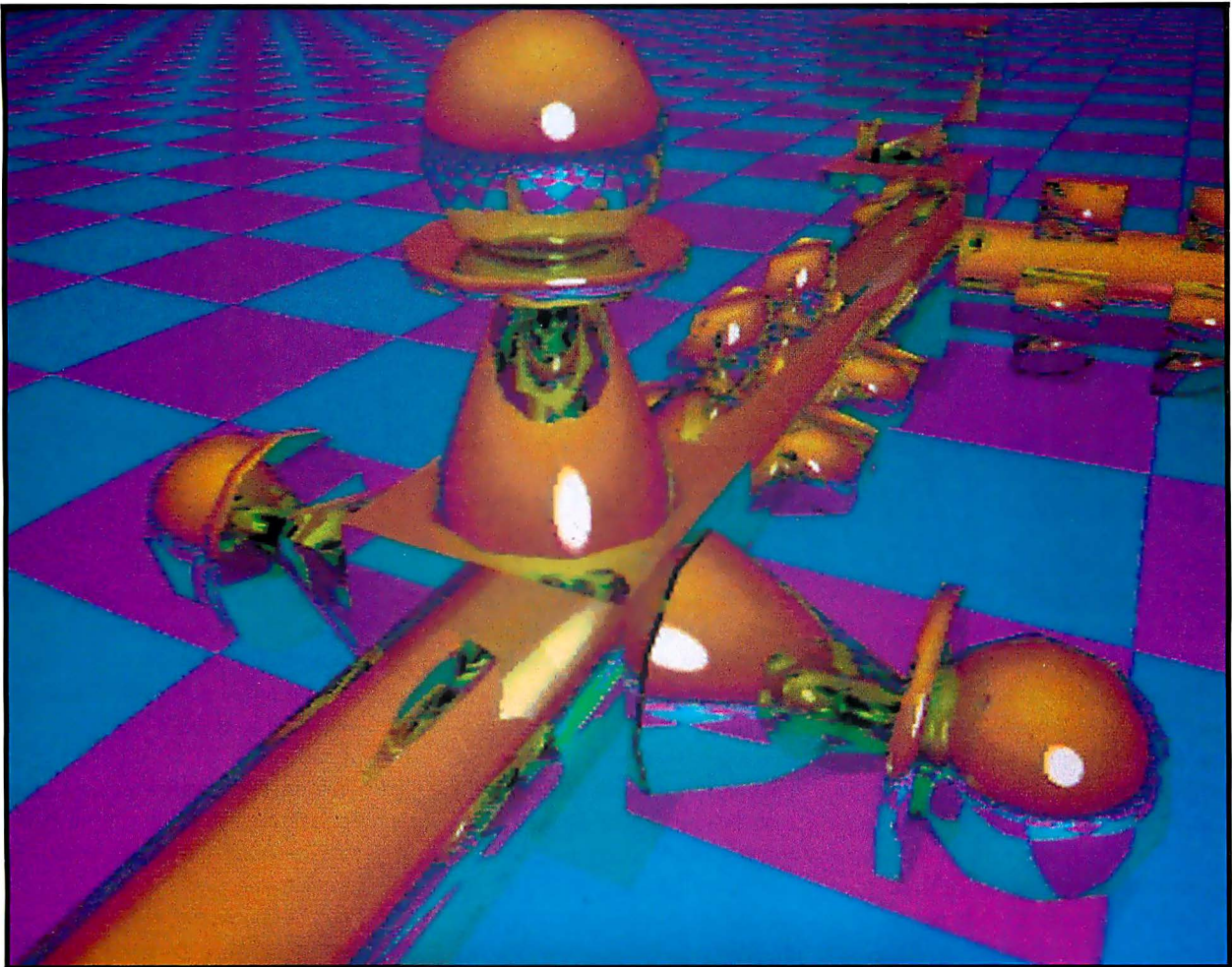

Mac II, Amiga, PS/2 Graphics
The RenderMan Standard
Scientific Visualization

8 New Reasons To Buy ARTIST™

1. Arris
2. ANVIL-5000pc
3. AutoSolid™
4. X-Windows
5. CADKEY
6. Hoops
7. VersaCAD
8. TOPAS/RIO



Plus Ten Well-Known Old Ones

1 Highly Software Compatible: An impressive list of over 200 graphic software products support the ARTIST™ Series. CAD, image processing and desktop publishing just begin the list of ARTIST applications.

2 Vast Product Line: The ARTIST Series includes 20 graphic controllers that range in resolution from 800 x 600 to 1664 x 1200. They display up to 16.7 million simultaneous colors and use Hitachi, TI and NEC graphic microprocessors to handle complex drawing commands.*

3 Single Screen Options: VGA, EGA, and CGA modules give you single screen workstations.* At the same time, they allow you to run popular software packages that support IBM graphic standards.

4 PC & MC Bus Compatible: We offer ARTIST graphic controllers for the IBM® PC/XT/AT, IBM PS/2 Micro Channel™

and compatibles. (Macintosh II products to be offered soon.)

5 Design Leadership: Control Systems was the first to produce a high performance graphic controller for the original IBM PC in 1982 and we repeated that effort in 1987 for the IBM PS/2s.

6 Peak Performance: We combine ARTIST controllers with ARTIST software drivers to give you fast, feature-packed graphic subsystems that few can match. Our ARTIST GT™ display list processing drivers give you instant zooms, birds-eye-views, transparent pans, and more.

7 High Customer Satisfaction: Our in-house testing procedures guarantee you smooth installation and operation. Less than 1% of ARTIST controllers are returned for repair.

8 Development Tools: We offer developer's toolkits for PGL, DGIS, X-Windows, and Hoops. Each has a com-

plete set of graphic primitives to speed creation of new software applications.

9 Immediate Customer Support: Call us on our hotline and get same day customer service for all your ARTIST products. We've been told it's the best in the business.

10 Years of Experience: 6 years of graphics experience go into the development of new hardware and software products. As long as you own your ARTIST graphic workstation, Control Systems will be there to support you and offer you advanced ARTIST products.



Control Systems

P.O. Box 64750 St. Paul, MN 55164
or call

1-800-826-4281

In Canada call

1-800-543-6523

International calls

1-612-631-7800

Circle 68 on Reader Service Card (DEALERS: 69)

*Note: ARTIST controller features vary from product to product. Specifications are subject to change.

ARTIST and ARTIST GT are trademarks of Control Systems, Inc. IBM is a registered trademark and PS/2 and Micro Channel are trademarks of International Business Systems. Images courtesy of MCS, CADKEY, VersaCAD, Ithaca Software, Autodesk, Sigma Design, AT&T GSL. AutoSolid is a trademark of AutoDesk, Inc. ©Copyright 1988 Control Systems

BYTE

Graphics Supplement



Variations on a Screen *by Phillip Robinson*

251

The RenderMan Interface *by Tony Apodaca*

267

Interacting with the Tiny and the Immense *by Craig Mundie*

279

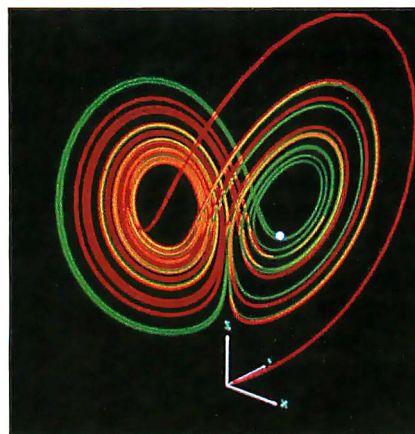

INSIDE COVER
RAY TRACING:
BRYAN CAREY GALLIVAN © 1989

The CalCompTM DrawingBoardTM Digitizer Family.

Now in A, B and C sizes.

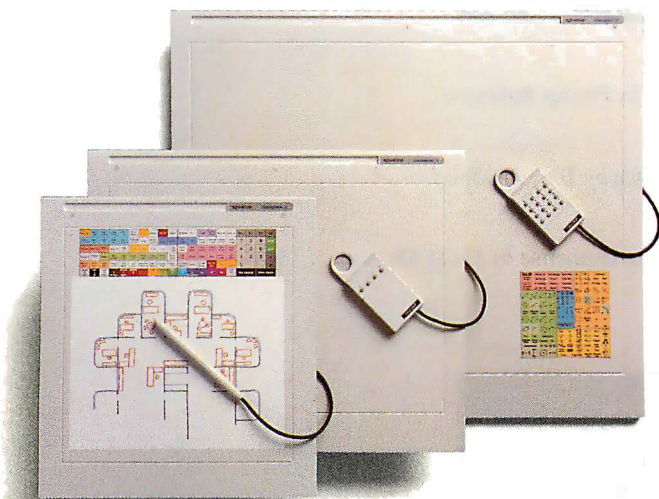

1. **Flexibility.** Quick menu picking. Also high resolution tracing and drawing. And selective resolutions of up to 1,016 lines per inch.

2. **Features users want most.** Sleek, rugged, wedge shape. Convenient built-in stylus holder. Adjustable plane positions. Power on indicator. Removable template overlay holder. Color matched to most PCs and workstations.

3. **CalCompatibility.** Supports over 50 major CAD and graphics software packages. AutoCAD, VersaCAD, Zenographics Mirage, and Ventura Publisher. Just to name a few.

4. **Built-in reliability.** CalComp's advanced technology reduces the number of electrical components.

5. **Warranty commitment.** We back our DrawingBoard with a special five year warranty, too.

With DrawingBoard you get a complete digitizing system, including your choice of a 4 button cursor and pen stylus. Or a 16 button cursor instead. Plus power supply and cable. Combine all this with a low price. And there's only one conclusion you can draw on. CalComp's DrawingBoard digitizers.

Call us at 1-800-CALCOMP. Or write us at CalComp, P.O. Box 3250, Anaheim, CA 92803.

We draw on
your imagination.TM



A Lockheed Company

We draw on your imagination and DrawingBoard are trademarks of CalComp Inc. Mirage and Autumn are trademarks of Zenographics. AutoCAD is a trademark of AutoDesk. VersaCAD is a trademark of VersaCAD Corporation. © 1988 CalComp Inc. Ventura Publisher is a trademark of Ventura Software, Inc.

Variations on a Screen

Phillip Robinson

What are the peculiarities of IBM PS/2, Macintosh, and Amiga graphics hardware?

Graphics used to be an afterthought on computers, an unnecessary frill. There were a few "graphics computers" with special hardware for drawing lines on a screen, but these were expensive machines aimed at narrow niches. The only graphics the early personal computers could boast was the ability to draw characters on a screen in neat rows and columns. That was OK for word processing, spreadsheets, and databases.

With some arm-wrestling, text displays could even produce simple drawings or game figures (using combinations of characters to represent objects and fill patterns). But only home computers that doubled as "game machines," such as the Commodore 64, Apple II, and Atari 800, had special hardware to automate such graphics operations as moving a colored shape from one part of the screen to another or determining when a particular shape was touching another shape on a display.

When the IBM PC came along, text mode was seen as the proper province for most business programs. The PC didn't even have its own text abilities built in but took its graphics cues from whatever "display adapter" circuit board you plugged into it. As the applications for PCs, and then for the closely related PS/2s, expanded to include drawing, charting, and presentation tasks, the display adapters added pure graphics modes with more and more colors and resolution.

The machines in the PS/2 line came with a built-in display adapter. A number of other companies developed display adapters that would work in PCs and compatible systems—adapters that might pack special "modes" with far more resolution and color ability than any offered by IBM. To use these adapters, however, you needed special driver software that was usually available only for a few big-name programs (e.g., AutoCAD, PageMaker, and Ventura Publisher). Some programs were even able to work with

two display adapters at once, which was useful, for example, in showing a CAD program menu on one monitor while the drawn image appeared on the other.

Then the Macintosh appeared, and it didn't even bother with a text mode for display. Everything was graphics, including the interface itself—used with every program—of icons, windows, and graphical cursors. Even writing text to the screen was a graphical act. For all this, the Mac had its own built-in video monitor, hardware, and firmware.

As the Macintosh line has evolved to the Mac II and IIX, this basic setup has persisted, although the monitor has been separated from the bundle, the software now provides color, and the graphics can be enhanced with plug-in display adapters. The Macintosh operating system can automatically handle up to six different monitors simultaneously. Because every Mac comes with a mouse for pointing at particular coordinates on the monitor, there is a standard set of commands for manipulating most Macintosh graphics programs. The PS/2 world has not become as settled as that for graphics input.

The Commodore Amiga goes a step beyond the PS/2s and the Mac in graphics hardware, borrowing and building on the special games circuits from the Atari and Commodore 64 era. Besides a graphical interface and firmware routines for

graphics, the Amiga has custom ICs that can speed graphics programs. What's more, those same chips provide games and animation features for the Amiga and give it an inside track for working with television signals. That makes it a natural for "desktop video" work.

In the rest of this article, I'll talk about the graphics hardware behind the PS/2s, Mac, and Amiga, go over a little history, describe how each works, and discuss their strengths and weaknesses. (The text box "Display and Video Buffer Fundamentals" on page 260 provides a general overview of the graphical environment common to the three systems.)

PS/2s

The PS/2s' graphics capability evolved directly from the IBM PC's graphics, so it is useful to first take a look back. The original PC, XT, and AT had no built-in graphics hardware. You bought a monitor and a video adapter board to go along with your PC. The board and the monitor were connected with a nine-wire cable. Programs had to be written to understand the various adapters to take advantage of their resolution and color.

IBM's Monochrome Display Adapter (MDA) could produce 80 columns by 25 rows of text and character-size symbols. CGA could do the same in color on an RGB display. CGA could also produce graphics, a pixel at a time, and it had a port for a composite video signal to feed to a TV set. (That composite ability, common in early personal computers, has fallen out of favor because TVs don't offer high-enough frequencies and resolutions for today's software.)

MDA's highest resolution was 720 by 350 pixels. Individual characters were formed in sets of pixels 14 high by 9 wide. CGA could manage only 640 by 200, and so made its same 80 columns and 25 rows of characters in sets of pixels 8 high by 8 wide. With nearly twice as

continued

Photo 1: The PS/2s' graphics capabilities evolved from the IBM PC's character-oriented displays but are now more flexible and updated and have higher resolution.



many pixels to work with, the MDA characters were much easier to read. CGA characters were at the bottom end of legibility. (Older personal computer systems with lower resolution often achieved legibility by compromising on the number of columns and rows displayed on the monitor. Take the same 640 by 200 resolution of CGA and break it into 40 columns by 20 rows, and you can make characters with several times the precision of the 80-column by 25-row standard. However, 80 columns does a good job of matching the number of characters that can fit on a standard typewritten page, so fewer columns can lead to lots of horizontal scrolling to see everything that will print on a page.)

Hercules was one of the few companies to independently establish a hardware standard in the world of IBM PC and compatible computers, with its Hercules Graphics Card (HGC). This video adapter with a resolution of 720 by 348 pixels in monochrome could handle MDA software (i.e., was MDA-compatible) and could produce pixel-by-pixel graphics in monochrome. The HGC Plus could work with RAM-based characters instead of the ROM-based characters that the MDA and HGC were designed to control. The Hercules InColor card added 16-color display (from a palette of 64) to the abilities of the HGC Plus.

The final step in popular PC graphics was EGA from IBM. (There were also adapters, such as the Professional Graphics Adapter [PGA], with higher resolution than the EGA, but they were expensive and never acquired a large body of compatible software.) EGA can run MDA or CGA graphics and was the first IBM adapter that could produce pixel-by-pixel graphics in monochrome. Its top resolution was 640 by 350 pixels, and it could put out 16 colors.

The more advanced cards offered a variety of modes with different resolutions and color abilities. While HGC had a single mode, CGA, for instance, had two graphics modes: 320- by 200-pixel four-color and 640- by 200-pixel monochrome. Software chose which mode to use and could switch from mode to mode depending on a program's needs. EGA had more than a dozen modes with vari-

The poor PC programmer had to write drivers for each possible adapter.

ous resolutions and specifications. Competing, compatible "super-EGA" cards offered special modes with yet more resolution. Some boards, such as the Truevision Targa series, provided a much larger color palette—a necessity for desktop video work.

The poor PC programmer had to write different drivers for each adapter the user might have and had to know about all these modes and resolutions. On MDA, CGA, and HGC, a Motorola 6845 video controller chip set the timing and other details of the video signal, and that's the chip programmers wrote directly to if they wanted to bypass the "famous" BIOS INT 10H (Interrupt 10h) for video routines or if they had an HGC (which the BIOS didn't recognize and thus required direct programming).

EGA had its own proprietary control-

ler chip. Companies that wanted to copy the EGA board had to create chips that were compatible with that special controller. The CGA board, incidentally, is famous for the "snow" or white specks it sometimes creates on a display if the program is trying to write directly to the video buffer. That direct work interferes somewhat with the information read and sent to the monitor. Another fascinating fact about programming the Motorola 6845 is that it represents one of the few places in computer programming where software can actually hurt the hardware. Use timing values that are too foreign to the monitor, and you could permanently damage parts of that monitor.

Not all monitors work with all video adapters. The higher frequencies of the EGA modes are beyond the abilities of some CGA-, HGC-, and MDA-capable monitors. The CGA and EGA boards can be run side by side with an MDA board, producing two outputs (one text and one graphics) from the same PC or PS/2.

The PS/2 line came with a pair of new, built-in display adapters. The Multi-Color Graphics Array (MCGA) on Models 25 and 30 works like CGA with greater resolution: 640 by 480 pixels, tops. VGA, found on all the other PS/2 machines, is a single chip that can handle all the EGA modes (although some programs need slight rewriting for compatibility) and has some new modes of its own. These include 720- by 400-pixel text and 640 by 480 pixel-by-pixel graphics. You can now also buy VGA-compatible display adapters for PCs, XTs, ATs, and compatibles. There are even super-VGA cards with modes that sport greater resolution than VGA's standard set.

Yet another new display adapter was announced along with the PS/2 line: the 8514/A graphics adapter. This separate board plugs into a special auxiliary video connector slot in the PS/2 models with the Micro Channel bus (i.e., Models 60, 70, and 80). It substitutes its own signals for those coming from the main board's VGA circuitry and can produce 1024- by 768-pixel resolution on an 8514A-capable monitor. With enough memory, an 8514/A board can also generate 256 colors from a palette of 256,000. At its 640- by 480-pixel resolution, the 8514/A can automate a few graphics tasks, such as programmable fonts and filling areas. The 8514/A may eventually replace VGA as the standard in PS/2 graphics, but it hasn't been very popular yet, perhaps because of the relatively high cost of the special board and monitor.

Both MCGA (which appears only on *continued*)

The End of Plain Vanilla PC Graphics

More Vibrant Colors and Higher Resolution. Any Way You Scoop it.

Now, Genoa dishes up more ways to eliminate the monotony of monochrome. Or the lifeless look of low-res color. With a brilliant line-up of IBM compatible graphics cards, designed to please any palate.

The creme de la creme in performance. For CAD and desktop publishing, get the ultimate in high performance: SuperHGA™, with an on-board graphics processor. It puts ultra hi-res images on any IBM 8514-compatible display with blazing speed. At 1024 x 768

resolution with 256 on-screen colors from a palette of 16 million.

Your choice of flavors, a la any mode. Genoa serves up a full menu of SuperVGA™ and SuperEGA cards. All of which extend the IBM standards—with VGA resolutions of up to 1024 x 768 in 16 colors in both non-interlaced and interlaced modes, and up to 800 x 600 in 256 colors.

The pint-size combo package. For sparkling color and monochrome graphics in one economical half card, choose our SuperSpectrum™. It's 100% CGA, MDA and Hercules compatible, with double scanned CGA for quality game images. Plus 132-column text for full spreadsheets.

So if your graphics board is producing nothing but "board-dom," go to your dealer today and order some Genoan graphic excitement. Call (408) 432-9090 today. Or write Genoa Systems Corporation, 75 E. Trimble Rd., San Jose, CA 95131; FAX (408) 434-0997, London 44-01-225-3247; Taiwan 886-02-776-3933.

IBM is a trademark of IBM Corp. Hercules is a trademark of Hercules Technology. SuperHGA, SuperVGA 16-bit Graphics Adapter, SuperVGA, SuperEGA HiRes and SuperSpectrum are trademarks of Genoa Systems Corp.

See us at COMDEX/Spring '89
Booth #4049

Insist on
Genoan Value.
GENOA



Circle 112 on Reader Service Card





Diamond Scan 14
Auto-Tracking
800 x 600 pixels (digital, analog, monochrome)
330 x 500 pixels (composite NTSC)

Diamond Scan 20A
Auto-Tracking
800 x 600 pixels (digital, analog, monochrome)
1024 x 800 pixels (maximum)

Diamond Scan 16L
Auto-Tracking
1024 x 768 pixels (typical)
1280 x 1024 pixels (maximum)

Diamond Scan 20L
Auto-Tracking
Up to 1280 x 1024 pixels

Actual unretouched screen images
Monitors shown with optional bases

A Clear View To Monitor Quality

VARIATIONS ON A SCREEN

PS/2 Models 25 and 30) and VGA (which is now being cloned by other firms and has become the PS/2 and PC standard video adapter) produce analog signals to tell a monitor what colors to display. They have D/A converter circuitry that turns the bits from the video buffer into analog waves on the lines to the monitor. MDA, CGA, HGC, and EGA all produce digital RGB output, with lines that signal either on or off for a certain color value. Analog output offers much larger color selections but must drive a monitor that understands analog information. Most monitors used with PCs, XTs, and ATs are digital and cannot move to the VGA level. Some monitors handle analog or digital. The MCGA and VGA formats can each produce 256 colors from a palette of 256,000, connecting to the monitor through a 15-pin cable.

The PC running conventional DOS doesn't use the same RAM for video as it does for programs and data. An area above the 640K-byte limit, well known to PC and PS/2 users running DOS, and below the 1-megabyte addressing limit of the 8086 processor is dedicated to video. The size and address of the buffer de-

pend on the particular display adapter, although all are between A0000 and C0000 (a 128K-byte area above 640K bytes). The memory chips for this are actually on the display adapter card, not on the main system board.

The information in the video buffer produces character codes (for text mode) or attributes (for bit-mapped mode) that are sent to an alphanumeric character generator or an attribute decoder. The information from these circuits is combined with the mode settings from the program and the timing information from the CRT controller to produce a video signal appropriate for the monitor.

The PC and PS/2s have no special hardware to help the CPU get the bits into the video buffer and no graphics accelerators or dedicated graphics function circuits. There are a few logical operations in the controller chips, but PS/2 graphics is mostly a matter of learning BIOS calls and collecting controller assembly-language routines. This makes the PS/2 line quite flexible for software jockeys who have studied the hardware's basics, but not well suited for animation or other complex software tasks. And with its text

modes, it can run simple, non-WYSIWYG, text-based applications—spreadsheets, word processors, databases—faster than the Mac or the Amiga.

Macintosh

The IBM PC began life without graphics, adding it through plug-in boards. The Mac was born with a built-in monitor, a built-in video adapter, and a large set of built-in graphics routines in system software ROM. The Mac's software is its most unique element—and its ability to show on the screen pretty much what you'll see in print is a big selling point. That software includes QuickDraw (a set of drawing routines for basic objects), a Font Manager (that uses QuickDraw to draw text characters on the screen), and a Window Manager (to draw and control windows on the screen that contain programs or file listings).

The Mac ROM has grown from an original 64K bytes of routines to a full 256K-byte ROM in the Mac SE and II. The newer ROMs include faster versions of the older routines and new software to provide color support, fractional-pixel-

Only one supplier of color monitors offers the widest selection of features and operating flexibilities in the market today.

That company is Mitsubishi Electronics. Mitsubishi® delivers the reliability and performance that can meet your color information display requirements today as well as tomorrow. Larger screen sizes, truer colors, and optimum resolutions make your work easier—and far more productive.

Whether your requirements call for fixed-frequency graphics standards, like EGA and VGA, or multiple-frequency performance, Mitsubishi has the color monitor

with the resolution and size to fit your specific needs. This includes the Diamond Scan Series of 14", 16" and 20" auto-tracking monitors, some with microprocessor-enhanced programmable display settings. All at very competitive prices.

To get a clear view of monitor quality and value, look to Mitsubishi.

For product information or nearest authorized Mitsubishi Electronics sales representatives, please call 1-800-556-1234, ext. 54M. In California, call 1-800-441-2345, ext. 54M. Mitsubishi Electronics America, Inc., Computer Peripherals Division, 991 Knox Street, Torrance, CA 90502, (213) 217-5732.



XC1429C
VGA Compatible
640 x 480 pixels

XC1410C/XC1430C
EGA Compatible
640 x 350 pixels

Mitsubishi Model	Screen Size (inches)	Horizontal Scan Frequency (kHz)	Mask Pitch (mm)	Compatibility/Resolution						
				VGA			Apple Mac II	1024 x 768 (48 kHz)	1280 x 1024 (64 kHz)	
				NTSC	CGA	EGA				Std.
Diamond Scan 14 (AUM1381A)	14/13V	15.7 ~ 36 auto-tracking	0.31	•	•	•	•	•		
Diamond Scan 16L* (HL6605TK)	16/15V	30 ~ 64 auto-tracking	0.31				•	•	•	•
Diamond Scan 20A (HA3905ADK)	20/19V	15.7 ~ 36 auto-tracking	0.31		•	•	•	•	•	
Diamond Scan 20L* (HL6905TK)	20/19V	30 ~ 64 auto-tracking	0.31				•	•	•	•
XC1429C	14/13V	31.5	0.28				•			
XC1410C	14/13V	22 or 15.75	0.40		•	•				
XC1430C	14/13V	22 or 15.75	0.31		•	•				

*Microprocessor-enhanced programmable display settings

Visit us at COMDEX — Booth #3643



© 1988 Mitsubishi Electronics America, Inc. Mitsubishi is a registered trademark of Mitsubishi Electric Corp., Tokyo. Screen images produced with permission from the following companies (trademarked software package name follows company name): Autodesk, Inc. (AutoShade); Computervision Corporation (Personal Designer); Computer Friends, Inc. (Modern Artist); SuperMac Software (PixelPaint); Three I/O Graphics, Inc. (Perspective); Microsoft Corporation (Excel Version 2.0).

And Value.

VARIATIONS ON A SCREEN

width characters, and so on. Above this ROM is an operating system that handles I/O and the Finder, a program that tracks directories and other disk operations.

The early Macs (including the Mac Plus and SE—or the Integral Video Macs, as Apple puts it) have a built-in, 9-inch diagonal monochrome monitor. The built-in video adapter offers one resolution: 512 by 342 pixels in monochrome. That works out to 72 dots per inch on the screen, the same as on the original ImageWriter dot-matrix printer that Apple sold for use with the Mac. It's also about the same as the 1/72-inch measurement in typography known as a *point*. (Later Apple would turn to the LaserWriter laser printer, with its resolution of 300 dpi, and use the drawing routines of PostScript to drive the higher-resolution printer while QuickDraw was still handling the monitor.)

On the Mac Plus and SE, the video buffer is formed in part of the standard system RAM, taking up 21K bytes. Both the Mac Plus and SE have two screen buffers: a main and an alternate. The display can be switched from one to the other with a quick change of a single

value in the controller—a useful procedure for animation. (On the Mac Plus and SE, each pixel is either on or off: Gray-scale effects come from combining groups of pixels into logical units and turning on or off a percentage of the pixels in each group to create intensity levels.)

Application and system software make

any changes to the bit-map image in RAM. On the Mac Plus and SE, a video controller on the main circuit board then shuttles the video buffer information to the monitor. It is possible to plug a color monitor into the Mac SE, but its ROM does not contain full QuickDraw support for color. That means that you must de-

continued

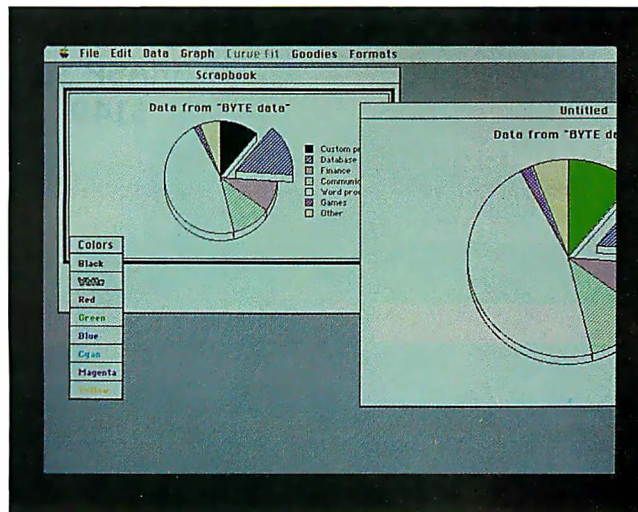

Photo 2: The Macintosh began life as a graphics-oriented machine—even the text is graphics—and has grown in sophistication with each succeeding generation.

pend on special software drivers for color in each program.

The Mac II and IIX can drive any of a variety of monitors, operating from plug-in video adapter boards much as a PC would. A board can also carry special processors, ROMs, and video RAM. The Mac II ROM supports color in QuickDraw. However, that support is only for 8 bits of color information per pixel, or a total of 256 possible simultaneous colors (from a palette of 16.7 mil-

lion). You can also choose to work with 2, 4, or 16 colors or gray levels.

Apple's own video card puts out either 640 by 480 pixels monochrome (with up to 16 intensity levels) on Apple's 12-inch monochrome monitor or, with enough on-board RAM, 640- by 480-pixel resolution in 256 colors or gray levels on Apple's 13-inch color monitor. The vertical scan frequency is 60 Hz, noninterlaced. That leaves it outside the realm of standard TV signals, so Macintosh

graphics cannot be directly recorded on standard VCRs. Nor can you use typical TVs or PC monitors with the Mac II because it, too, has a noninterlaced (480-line) display.

Some firms make 24-bit video adapters for the Mac that can display as many colors simultaneously as there are pixels on the screen. Unfortunately, these cards need special software drivers to take advantage of the full range of colors: Apple's system software and ROM have not yet come to support this "full color" and provide it to all programs, but this may happen this year or in 1990.

Most of the competing monitors are larger than Apple's. Some of them offer the same or nearly the same number of pixels as the Mac Plus and SE, but on a larger screen, and so have fewer dots per inch. Others have the same or greater dpi counts than the Mac Plus and SE, and so put many more pixels onto the larger screen. Resolutions range from that original 512 by 342 pixels to as high as 1664 by 1200 pixels. (Remember, however, that 1200 lines on a screen 24 inches tall do not make characters and objects more precise than 400 lines on a screen 8 inches tall. Both screens have the same dots per inch, but the larger monitor can hold more of a large image or more images at the same time.)

The Mac's operating system can run multiple monitors at the same time and offers a utility for selecting which one has the main menu bar and how the monitors are logically positioned with respect to each other (i.e., how the cursor moves from one to another). The monitors may come with extra software that adds special zooming or other view-control features.

The Mac does not have any special hardware for graphics acceleration or automation. What it does have is a well-crafted and refined set of system routines stored in a large ROM—routines for creating, organizing, and tracking graphics on the screen, including windows, drawn graphics, imported pictures, and just about anything else.

All the actual figuring and data movement are handled by the main processor: the 68000 chip in the Mac Plus and SE, the 68020 in the Mac II, and the 68030 in the Mac IIX. The increased main processor speed of the Mac II's 68020 and the Mac IIX's 68030, as well as the built-in floating-point math coprocessor, directly contribute to graphics speed because the CPU/FPU pair does all the graphics calculation work.

Having a graphical interface to a program is easier on the Mac than on the PC,

continued

Animation tools that "far outshine those of other popular graphics presentation packages." —PC Magazine

Program in the 4th Dimension...
ANIMATE!

Get unlimited action and interaction with the most powerful PC animation system available, by calling Grasp routines from your programs in C, Pascal, Basic, and other languages.

Or develop your graphics applications directly in Grasp! Take advantage of:

- 74 animation & effects commands
- 25 predefined fades
- single-command animation
- all major graphics modes
- screen capture and graphics printing utilities

Includes Pictor, a full-featured paint program, completely integrated with Grasp for fast development and editing of programs and graphics.

GRASP 3.1
\$149

Convince yourself!
Send us \$2.00 for Episode I
"The Adventures of Ferguson Floppy"

Paul Mace
SOFTWARE

400 Williamson Way
Ashland, OR 97520
800-523-0258

OUR MOVE

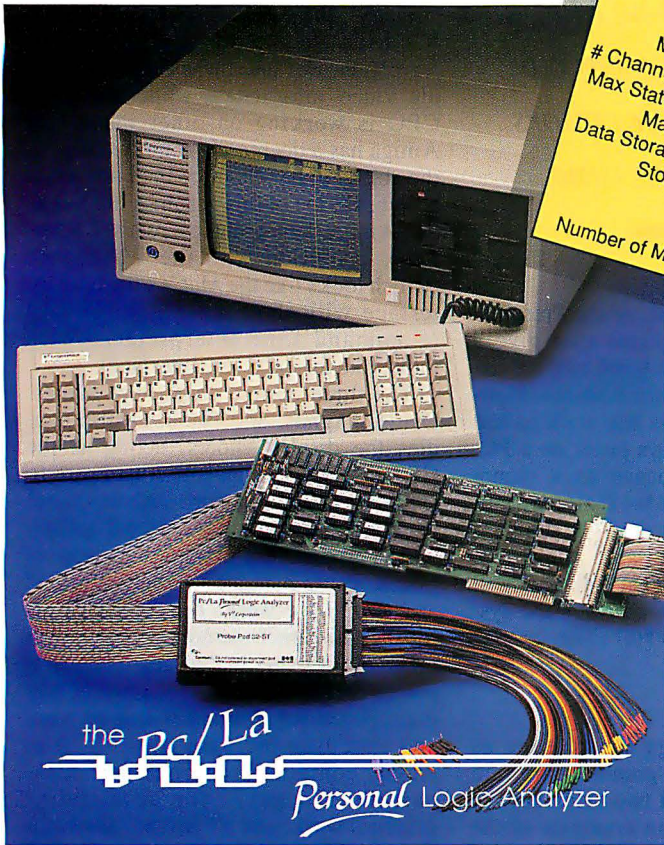

	Pc/La	HP1651A *	Phillips 3633 *	Tektronix 1220 *
Total Channels	32	32	32	32
Max Timing Rate	100 Mhz	100 Mhz	100 Mhz	100 Mhz
# Channels @ Max Rate	16	16	8	8
Max State change Rate	25 Mhz	16.6 Mhz	12.5 Mhz	10.0 Mhz
Max State Clock	50	25	25	25
Data Storage (per chan)	4K	1K	1K	2K
Storage Method	Linear	Transitional	Linear	Linear
Trig Method	Multi-Way Branch & Loop	Linear	Linear	Linear
Number of Match Regs	28	Sequential	Sequential	Sequential

* Based on published specifications

In the mid to late 70's, when engineers designed with SSI and MSI, the demands that they made on logic analyzers reflected the technology that they worked with - low density, low complexity, and low performance.

Along came the 80's and with it PALs, GALs, PLAs, LCAs, ASICs, faster CISCs, and RISC machines. Technology leaped ahead... same old logic analyzers.

Finally, a machine tuned to the times. The Pc/La provides you with competitive sample speed and channel count, but more importantly, its superior trigger capabilities enable you to track down system bugs quickly and efficiently. No fumbling around the edges or shooting in the dark, you are right where you need to be.

There is no need to translate your problem into someone else's idea of logic definition. This instrument uses state syntax directly.

The Pc/La is packaged as a single add-in card for an IBM Pc/XT/AT or compatible. This means that you already own 50% of an efficient, high-performance hardware and software troubleshooting instrument. The other half is yours for less than \$2000.00.

The Pc/La - the only logic analyzer to earn the right to use the word *analyze* in its name.

Take it from here, now it's.....

YOUR MOVE

(416) 266-5511

285 Raleigh Avenue, Toronto, Canada. M1K 1A5

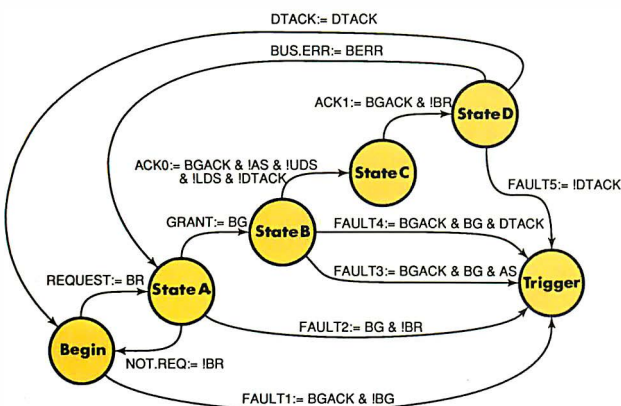

Trigger program to detect 1 of 5 possible faults in the DMA cycle of a MC68000. This example uses only a fraction of the capabilities of the Pc/La.



Destroy all circuit bugs!

© 1988 **V³ Corporation**

PAL is a trademark of Monolithic Memories Inc., GAL is a trademark of Lattice Semiconductor Corp., LCA is a trademark of Xilinx I.B.M. is a trademark of International Business Machines Corp. MC68000 is a trademark of Motorola Semiconductor.

EZ-DOS

Break the stranglehold on your PC.

Digital Research & 2001 Sales have developed EZ-DOS as an enhanced replacement for your current DOS.

Now you can use the sophistication of EZ-DOS instead of accepting the limitations of another DOS.

The main features of EZ-DOS are:

- * DOS compatibility
- * Multiple 512 megabyte partitions - quit dissecting your hard disks
- * Password protection of files and directories
- * Full screen text editor
- * On-line HELP for command syntax
- * Command history
- * LIM 4.0 Extended memory driver
- * Menu based installation that works with all compatibles

GEM Desktop™

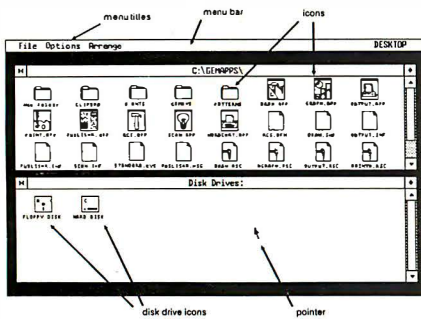

- * A true graphic, windowing operating environment - GEM/3 Desktop is our user interface.
- * Inexpensive - compare costs

EZ-DOS 4.1 Deluxe..... \$79.00
 plus True BASIC..... \$99.00
 plus serial Mouse..... \$139.00
 plus T.BASIC & Mouse.. \$159.00

2001 Sales, Inc.

16580 Harbor Blvd., Ste. D
 Fountain Valley, CA 92708.

Tel: (714) 531-6551

Fax: (714) 531-8546

Dealer, Distributor & OEM Inquiries welcome.

VISA and Master Card accepted.

258 B Y T E • Graphics Supplement

VARIATIONS ON A SCREEN

The Mac's operating system can run several monitors at the same time.

where Windows, GEM, or the Presentation Manager (programs that give a "Mac look" to a PC) labor without the help of tailored firmware routines. However, simple programs that stick to text mode are nearly always faster on a PC. Although the Mac began as a monochrome machine, the Mac II already provides richer color than the VGA standard on the PC (with the same number of colors from a larger palette) and will move even farther ahead when the system software supports full color.

Amiga

Commodore's Amiga can be seen as either the next step in graphics hardware beyond the Mac (and two steps beyond the PS/2 line) or as an amalgam of the general-purpose graphics of the Mac and the special-purpose graphics of earlier game computers from Atari and Commodore. From the original Amiga 1000 to the less expensive and less expandable Amiga 500 and the higher-powered 2000, the Amigas begin with a 68000 central processor just like the Mac's. The Amiga 2500 adds a 68020 processor board to a 2000 frame, increasing the main processing speed.

All Amigas use the same graphics strategy. Instead of leaving the 68000

CPU to handle all the graphics calculations along with its other chores (the Mac strategy), the Amiga has a trio of custom ICs dedicated to processing graphics information. Because these chips can handle video information while the main CPU is working on other tasks, the Amiga has a degree of "multitasking"—the ability to handle more than one job at a time. On top of this graphics hardware, the Amiga has a choice of user interfaces: Intuition with the Workbench (which looks like the Mac's graphical interface with the Finder), or the CLI (Command Line Interpreter, which looks like the DOS text interface).

The three custom chips have names: Denise, Agnus, and Paula. Denise handles the display chores, acting as the CRT controller. Agnus has hardware to automate animation work such as special registers to maintain and propel *sprites*, which are object-oriented groups of pixels. Paula handles a variety of sound and disk drive work, besides providing for the fast direct-memory-access movement of information within the computer. DMA transfers don't tie up the main processor, leaving it free to work and speeding the data transfer. And Agnus contains a coprocessor, nicknamed "Copper," for accelerating graphics work, and a "Blitter" for hardware bit-block transfer operations such as line drawing and color fills.

Unlike the PS/2s and the Mac, the Amiga is quite flexible when it comes to choosing a monitor. In fact, it has ports for RGB monitors, composite monitors, and standard TV sets. It can even drive all three at the same time because each port constantly provides the same display information, each in its particular format. The RGB monitor port provides analog signals, though it can be adapted to

continued

Photo 3: The Amiga can be seen as an amalgam of the general-purpose graphics of the Mac and the special-purpose graphics of early Commodore and Atari game computers.

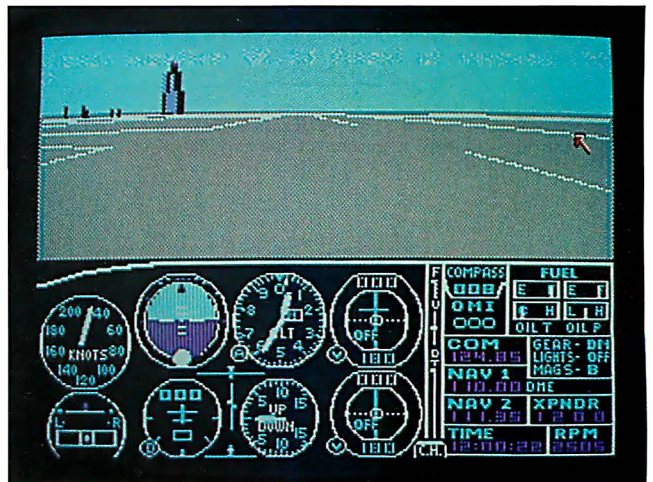

Share Your Precious Resources . . . And Save!

When you can't afford to buy a laser for each PC, the **BuffaloSL™** is the inexpensive way to let everyone share - not just your lasers, but printers, plotters and modems as well. An **SL** with memory improves PC productivity like a printer buffer, but is a more sensible investment since **SL** memory is shared by all peripherals. If you don't need simultaneous access to shared files, the **SL** is also an alternative to a LAN at a fraction of the cost.

The **SL** has four parallel and six serial channels, with all ten being user configurable as either an input or an output, so you can share any combination of PCs and peripherals. If you need more than ten channels, you can link several **SLs** together. All channels can be in use at the same time to rapidly transfer data and quickly release your PCs to continue working instead of being delayed for printing. The **SL** software even allows your PC to send data at 19,200 baud. All memory (user upgradeable up to 4MB) is dynamically allocated and efficiently shared by all channels as needed. The **SL** comes with menu-driven software to install the pop-up menu for easy selection of printers and control options, but you don't have to be a programmer to use it. Of course, the **SL** works just fine without our software too! The **SL** has many other features so ask us to send you more information.

When you compare the price and capabilities of the Buffalo SL with any similar devices, we believe you will agree with thousands of well-informed professionals that the SL is the best value available anywhere!

ONLY

\$500

Plus \$100/256KB
Up To 4MB

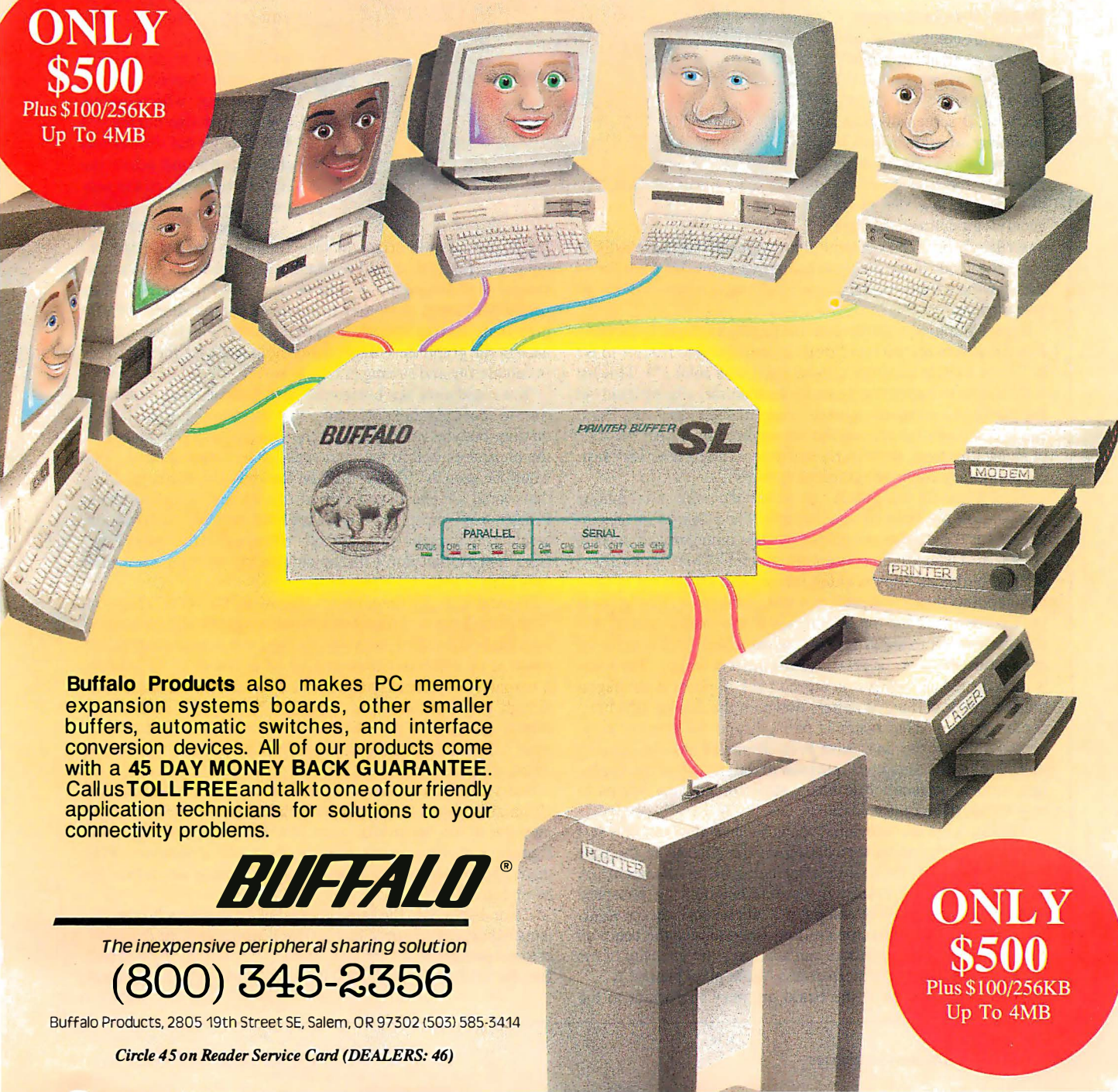

Buffalo Products also makes PC memory expansion systems boards, other smaller buffers, automatic switches, and interface conversion devices. All of our products come with a **45 DAY MONEY BACK GUARANTEE**. Call us **TOLLFREE** and talk to one of our friendly application technicians for solutions to your connectivity problems.

BUFFALO®

The inexpensive peripheral sharing solution

(800) 345-2356

Buffalo Products, 2805 19th Street SE, Salem, OR 97302 (503) 585-3414

Circle 45 on Reader Service Card (DEALERS: 46)

ONLY

\$500

Plus \$100/256KB
Up To 4MB

Display and Video Buffer Fundamentals

This text box provides an overview of two essential elements of the graphics hardware environment. The first is display fundamentals: How do 1s and 0s light up a CRT? The second is video buffering: How does the computer manipulate the data?

Display Fundamentals

Nearly all computer graphics are shown on a CRT video display or monitor. (A few images are sent to primary LCD screen displays, and many are transmitted to peripheral devices such as film recorders or printers, but they follow the same general guidelines that are

described here.) The computer hardware and software work in concert to control the electron beam that paints information on the viewing surface of the display—telling it where to aim and when to fire.

Vector graphics systems store the graphics images in memory as a list of vectors (such as “draw a line this wide from A to B” or “draw a circle at center x, y and fill it with color z ”). This list is then used to control the beam in the monitor, aiming it only at the points the computer system wants to show, drawing lines, circles, and other shapes on the screen directly. That’s the style of an oscilloscope, some early computers, and a few, very fast, contemporary computer graphics systems.

Most personal computers use *raster scanning*, a technique that controls the beam in another way. The graphics images intended for the display are stored by the computer as a mass of points in a Cartesian coordinate system. This “pointillist” method builds all sophisticated images and all text out of individual points that are on, off, or a particular color. The beam in the CRT starts at the top left corner of the display and strokes across from left to right. It is turned on whenever it is pointing at a picture element, or *pixel*, for the current image. The beam is then turned off while it is moved back to point at the beginning of the next line, or *raster*, down on the display (the horizontal retrace). That raster is painted, and the process is repeated until all the lines have been displayed and the beam is turned off while the aim is returned to the top left of the display (the vertical retrace). The beam then immediately begins to scan across the monitor again.

You don’t see the individual scans because they are very fast and because the phosphor coating on the surface of the tube continues to glow for a while after being hit by the beam. (A pixel may actually consist of several neighboring phosphor spots on the screen.) The computer’s video subsystem or interface provides the information telling when to turn the beam on and off. (Gray-scale monitors can also vary the intensity of the beam, so that it leaves a more or less bright pixel behind.)

The characteristics of the beam are very important to the

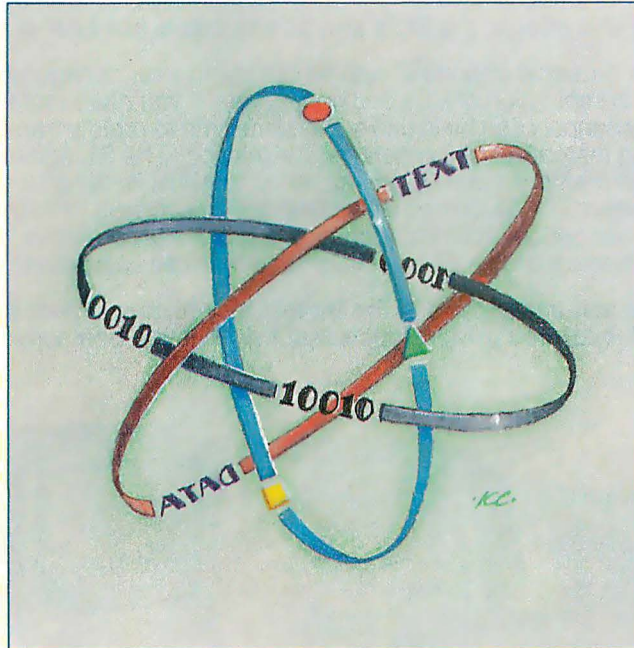

computer system. The faster it can turn the beam on and off (the dot-clock or video frequency), the more pixels can be crowded on a line (horizontal resolution). The faster it can move across a line (the horizontal scan frequency) and return to the next line, the more lines (vertical resolution) can be squeezed onto a display image. More lines and pixels mean higher resolution. Some displays also use *interlacing*, which paints every other line during one run through the display and then returns and paints the in-between lines on the second pass.

The equations determining resolution are horizontal scan frequency/vertical scan frequency = lines of vertical resolution, and video frequency/horizontal scan frequency = dots of horizontal resolution. More resolution means smoother diagonal lines and more color or gray-scale mixing options, and this generally aids the appearance of the graphics. It also means more work for the computer in calculating and storing pixels, however.

You could slow the horizontal scan frequency to gain more time to squeeze more dots onto a line for greater horizontal resolution, but you run the risk of the image starting to fade from the phosphors before the next scan cycle comes around. That would be seen as “flickering” on the monitor, the same thing that would happen if you slowed the vertical scan too much. Longer-lived phosphors could fight that problem, but then you would run into the problem of “ghosting” and “smearing” from images that don’t disappear quickly enough when their time is up.

Typical U.S. TV frequencies, following the NTSC (National Television System Committee) standard, are 60 Hz for vertical scan (although this is with interlacing; the entire image is updated at an effective frequency of 30 Hz) and 15.75 kHz for horizontal scan. That generates up to 262 lines resolution, although some of these are typically beyond the edge of the display and so aren’t visible. Some time is also lost to “overscan,” that is running the beam beyond the left and right visible edges of the display.

For a monitor to know when to retrace, it must be given synchronizing signals, with the vertical sync some exact integer multiple of the horizontal sync. TV broadcasts contain these signals; computers must provide them for a monitor. With them, the computer can precisely control when and where the beam is aiming.

Color displays do the same general work as monochrome systems but depend on three beams that illuminate three different-colored phosphors on the tube surface. (A few get by with one gun for all three phosphors.) This RGB (red, green, and blue)

continued

NOW YOU CAN DESIGN JUST ABOUT ANYTHING... INCLUDING YOUR OWN CADD SYSTEM!

PC
MAGAZINE
EDITORS
CHOICE
CADD
3.0



Anyone can produce a computer-aided drafting and design package that sells for thousands of dollars. But creating one that's fast, powerful, and affordable takes real ingenuity.

That's exactly what we've done at Generic Software™. We sell the most widely used CADD program in the world for under \$500.

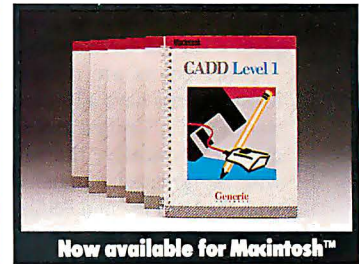

Now available for Macintosh™

PC Magazine ranked it "Editors Choice" in a face off with 17 low-cost CADD packages. "This product is an outstanding value from every point of view and is highly recommended." "A paperback version of AutoCAD", stated PC Week.

And our CADD programs are just part of what we offer.

You can start with Generic CADD Level 1,™ then advance to other levels as your needs—and skills—expand.

And you can use our CADD add-ons, Utilities, and symbols libraries to design the CADD system that fits your needs.

You only pay for the functionality you need, and the functionality you get has depth.

Critic tested, market approved. Generic Software offers price, quality, and support. Match our customer support against anyone!

- Unconditional 60-day guarantee on most products
 - Unlimited free technical support
 - Free monthly newspaper
 - Regular updates at modest prices.
- All adding up to prove that the only thing generic about us is the price.

Call us for a free CADDalog™ or for the name of your local dealer: 1-800-228-3601.

© Generic Software Inc., Level 1 and Generic CADD are trademarks of Generic Software Inc., 11911 North Creek Parkway South, Bothell, WA 98011. Macintosh is a trademark of Apple Computer Inc.

Generic

S O F T W A R E

Circle 110 on Reader Service Card
(DEALERS: 111)

mechanism requires at least three input signals from the computer, one for each color. A true RGB monitor needs to have these three signals on separate wires. A composite color monitor, much like a TV, can be driven by a single wire that packs all three signals. Because the RGB information is combined and then separated again for a composite system, the resulting picture isn't as clear as on a strictly RGB monitor.

Other colors are made by combining the primary colors. Most systems have a limited number of simultaneous on-screen colors and a limited palette from which those colors can be chosen. Typically, the highest resolution cannot be reached with the greatest number of colors. That's certainly the case with the IBM PC and PS/2s. The Mac, with its fixed resolution, doesn't live by that law. These limits have moved higher as graphics has become more important on personal computers.

Video Buffer Fundamentals

Nothing happens on the monitor that hasn't first been thought out in the computer. For raster-scanned graphics, personal computers use memory-mapped video. That is, they store a logical mock-up of the entire screen's image in a block of RAM called a *video buffer* or *frame buffer*. This series of 1s and 0s can be translated and communicated to the monitor as signals to turn the beam on and off. Application program or operating system operations then change the pattern in RAM, inspecting what is there already and changing it when necessary because of program conditions. The program doesn't even need to know there's a monitor; it just deals with the buffer RAM. The monitor doesn't need to know there's a program; it just accepts information from a video controller that reads the buffer.

Both the CPU running the program and operating system and the video controller have access to that video buffer memory, but not at exactly the same time. Typically, a computer's CPU makes changes to that buffer during the relatively long vertical retrace and lets the video controller have it during the actual raster scans.

There are "video RAM" chips in some advanced computers that have two ports and thus can be manipulated by the CPU and read by the video controller at virtually the same time. A system may also be set up to use multiple buffers if it has enough RAM. In that case, changing the image on the screen can be accomplished simply by telling the video controller to look to another base address in RAM for its next scan's worth of information. The newer buffer's details are sent to the screen while the older buffer is left alone, free to be massaged and modified by the CPU. Later, another instruction can switch back to the original buffer's address. This technique is very important in animation, where large-scale, fast changes are paramount.

A single bit in the video buffer can determine darkness and lightness for a single pixel. Multiple bits can be used in groups to represent the color of a single pixel. This video buffer information can be kept in the same RAM that programs and data are stored in, or kept separately.

The multiple bits of a color pixel cannot be stored physically together and are often gathered into *bit planes*—multiple video buffer blocks of the same size that are logically overlaid. When it comes time to send the information to memory, the bits in the same relative positions of each block team up to specify the gray intensity or color of a pixel. This interleaving is different from system to system and display mode to display mode. It makes more memory control work for the video controller that must feed out the various bits about each pixel at the same time, either to directly drive an RGB monitor or to modulate a composite signal for a monitor. Some computer systems have spe-

cial hardware registers to streamline this process of bit-plane organization.

Special hardware can also be added to a computer system to accelerate the typical calculations of a graphics program or routine. In this respect, a general-purpose math coprocessor can be a boon to graphics work. But there are special functions that you won't find on typical math coprocessors, functions that are relevant only to graphics. Advanced video controllers may contain graphics coprocessors that can accept macro instructions such as "draw a line" or "place a circle." These coprocessors can offload some of the video buffer manipulation work from the main CPU.

A more specialized graphics function can also be put into silicon. The Bit-Blit operation (bit-block transfer), for example, can move an entire group of pixel values at a time from one buffer position to another (and so move a screen image from one position to another) and logically compare them to the pixels in the new position. Doing that one elemental microprocessor instruction at a time can be very slow. A circuit dedicated to handling the same task can do the job in a fraction of the time and possibly leave the central processor free to do other tasks.

There are also graphics elements, such as *sprites*, that can be implemented in hardware instead of software. A sprite is a group of pixels that moves around on the display as though it represented a single object (these are very popular in game programming). Sprites can be created by software, but if the hardware in a computer has special registers for pointing to the sprite values in RAM and for automatically checking the position of active sprites (which is touching which, and which should be given priority when two or more overlap), the programmer's job is simplified and the program can run more swiftly.

Text-mode raster graphics confines characters to set areas, such as a block of 8 pixels by 8 pixels. A counter or character clock can be used to keep track of which area is being addressed, and a character ROM (containing permanent pixel maps of the characters in a set) or RAM (containing disk-loaded or program-created character maps for the 8- by 8-pixel blocks) is then questioned to see when pixels are lit and when they are dark. Bit-mapped raster graphics, on the other hand, works entirely on an individual pixel basis, without resorting to character blocks. This approach is necessary for sophisticated raster graphics, and it can also handle text. With text, it offers more flexibility in fonts and relative position of characters, but it also makes lots more work for a graphics system and CPU that have to figure out just where and what a character is. Text-mode operations can be several times faster than bit-mapped operations of the same work.

Finally, there is the question of firmware, the graphics software routines that are turned to hardware in ROM, EEPROM, and other special chips. These routines are, in effect, part of the system software, but they are also part of the computer's hardware. Using the routines makes for "well-behaved" programs that avoid disruption of other programs by following the rules. However, using these routines can also slow a program's performance.

Many programs, particularly on the IBM PC—where the interface is not as standardized as on the Mac and Amiga—write information and controls directly to the video buffer and the video controller, bypassing the slow BIOS routines. Such programs aren't as "device-independent" as programs that stick to the regular channels, and they run a risk of breaking under future versions of an operating system.

ANOTHER GREAT OFFER FROM
THE EMPLOYEE-OWNERS* OF AVIS, INC.

Drive An Elegant Bargain.

\$49 a day. Cadillac Sedan de Ville. 100 miles/day included. 30¢/mile thereafter. Optional Collision Damage Waiver \$9/day in Cal., \$10.95-\$12.95/day elsewhere. Rate not available in Illinois and New York.

The employee-owners of Avis, Inc. want you to experience the elegance of a Cadillac Sedan de Ville or similar luxury-group car at a very economical rate. With SuperValue Rates and fast service, we're trying harder than ever to give you what you want in a rental car.

To get this low rate, here are some things you should know. The rate is available at select U.S. corporate and participating licensee locations.

It is nondiscountable and may change without notice. These cars are subject to availability. Blackout periods and additional seasonal charges may apply. There is no refueling charge if you return your tank full. There's a \$5-\$10/rental charge for additional drivers (no extra charge in Cal.). Renters under 25 pay \$5-\$10 extra/day where applicable. Cars must be returned to renting location. Local taxes and Personal Accident Insurance, Personal Effects Protection and Additional Liability Insurance are extra.

To drive this elegant bargain, call Avis at **1-800-331-1212** or your travel consultant.



We're trying harder than ever.SM



*Employees at all corporate locations. © 1989 Wizard Co., Inc.

Avis features GM cars. Cadillac Sedan de Ville.

work with digital monitors. Either type of RGB monitor will make a sharp picture. Next in quality is the composite monitor, with a standard TV far behind.

In the early versions of the Amiga, the computer was customized for either European use (where the TV standard is PAL) or for use in the U.S. (where the National Television System Committee standard prevails). A new version of the custom chips that should appear this year is supposed to allow any Amiga to pro-

duce either PAL or NTSC signals.

Because the Amiga has a TV port, you can directly record any Amiga graphics on a standard VCR. What's more, the custom chips can match their own video synchronization signals to those of an outside source when you plug a so-called "genlock"-compatible peripheral into the Amiga. That means that you can capture single frames from a video stream for modification by Amiga graphics programs and that you can directly overlay

standard broadcast or recorded video images with images produced by the Amiga's processors. Neither the Mac nor the PS/2s can go that extra mile without modification and special hardware.

The Amiga display resolutions range from 320 by 200 pixels to 640 by 400 pixels. It can handle 32 colors at a time from a palette of 4096 (or 16 at a time in the highest-resolution modes). A special Hold and Modify (HAM) mode can put all 4096 colors on the screen at once. The Amiga's video buffer is separate from the system RAM and has grown from 512K bytes to a full megabyte of RAM.

The custom chips provide hardware controls for fast manipulation of five bit planes and have special registers and circuits to allow a "dual playfield" (a front image and a rear image that can overlay). Animation subroutines in the system ROM permit smooth movement of objects with a minimum of programmer work. The new Denise chip is expected to add some new display modes, up to 64 colors, and a larger-capacity blitter.

A special video applications graphics mode with resolution of 1280 by 400 pixels interlaced may catch the eye of desktop video enthusiasts. The new chip will "drop in" to the chip sockets of existing Amiga 500 and 2000 models. Commodore is also developing a Professional Video Adapter (PVA) for the Amiga that will be able to generate broadcast-quality titles with smooth color blends and backgrounds.

Although the Amiga can run in a mode similar to the PC's text mode (with the CLI) and can produce WYSIWYG text on-screen, like the Mac's interface provides (with Intuition), its smaller market share has led to a smaller library of programs. The Amiga has also fallen behind the Mac II in the sheer number of colors that can be displayed on the screen—and so is less competitive as a design and industrial or business graphics tool. The Amiga's real strength is shown in pure graphics tasks such as games, animation, and video work. There, it has a clear advantage over the PC or the Mac, with direct connections to standard video formats and with special graphics acceleration hardware to produce smooth and more realistic games and graphics applications. ■

Phillip Robinson, a former engineer and BYTE senior technical editor, is now a BYTE contributing editor who writes about CAD and graphics. He is a founding editor of PIX, the magazine of digital photography and still video. He can be reached on BIX as "robinson."

OCULUS™ - 10

A real time video digitizer for the VGA adapter.





OCULUS™ - 10 lets you:

- Grab images of moving scenes into your computer
- From all standard cameras and VCR'S
- In either Monochrome or full, true colors
- With VGA resolution

Contrary to competing products which take several seconds to scan an image, **OCULUS™ - 10** grabs most images in 1/20th of a second or less. Our software updates them on your VGA board at a rate of up to 5 images per second. **OCULUS™ - 10** gives you full freedom for:

- Digitizing images of live subjects
- Framing
- Focussing
- Selecting scenes from video recordings

Images can be saved in formats compatible with most electronic publishing and graphics software packages.

OCULUS™ - 10! A half-size add-on board for IBM-compatible micro-computers: PC, XT, AT, 386, and PS/2 models 25 and 30. The price? An unbelievable

ACTUAL UN-RETOUCHED PHOTOGRAPHS OF IMAGES GRABBED BY OCULUS™ - 10



SUPPLIERS OF HIGH QUALITY IMAGE PROCESSING PRODUCTS SINCE 1983

\$ 695.

To order, fill out the coupon, or call us:
 IN THE US: 800-361-4914
 OTHER: (514) 333-1301
 FAX: (514) 333-1388

CORECO INC.
 6969 Trans. Canada Highway
 Unit 113, Saint-Laurent, Quebec, Canada H4T 1V8

Please rush me an OCULUS™ - 10 board, with utility software and Coreco's 3 months warranty, for \$695 (US currency) plus \$15 for shipping.

NAME

ADDRESS
 STREET CITY

STATE ZIP

PHONE

VISA MASTER CARD EXP

CARD #

SIGNATURE

Specifications
 On-board memory: 128 Kb
 A/D converter: flash, 6 bits

FRAME-GRABBING TIMES:
 Monochrome:
 320 x 200, 4 bits: 1/60 second
 320 x 200, 6 bits: 1/20 second
 640 x 480, 4 bits: 1/30 second
 Color: 320 x 200: 1/20 second

Super VGA mode soon available.

IBM, IBM-PC, XT, AT, PS/2 are trademarks of International Business Machines Corporation

DEALER INQUIRIES WELCOME.

Finally, a Mouse That Won't Tie You Down.



The New Cordless Manager Mouse

Finally, a mouse that won't hold you back.
Manager Mouse Cordless, the world's first and only cordless mouse.

Better by design, it offers variable resolution, from 10 - 1000 dpi, and the reliable, maintenance-free performance that's become a trademark of the Numonics Manager Mouse line.

Amazingly simple to operate, Manager Mouse Cordless is compatible with virtually all mouse-driven software.

It's one mouse that breaks away from the pack.

SEE US AT BOOTH 1865
COMDEX/SPRING '89
APRIL 10 - 13 1989
McCormick Place, Chicago, IL



NUMONICS

101 Commerce Drive, Montgomeryville, PA 18936
Telephone: (215)362-2766 • TWX: 510-661-6585 • FAX:215-361-0167

NUMONICS EUROPE
Tiensesteenweg 307
B-3200 Kessel-Lo, Belgium
Telephone: 32(16) 25 58 70
TWX: 23354 + NUMEUR FAX: 32(16) 25 32 68

NUMONICS UK
The Creative Workshop
Lovel Road, Winkfield
Berkshire SL4 2ES, England
Telephone: 44-344-886436 FAX: 44-344-886588

FLEXSCAN™ 9070S, PC Hi-Res That Looks Like a Million.

The FLEXSCAN 9070 Multiple Scan monitor is of course compatible with other multi-scans, but includes improvements that will give you the professional edge which is the mark of a good investment. You can extend your multi-scan range from 20kHz to 50kHz in practical terms. This means that, at the 48-50 kHz range, you can make use of PC CAD/CAE capabilities at a resolution of up to 1024 dots X 768 lines. The FLEXSCAN 9070 takes advantage of non-interlace high resolution signal as high as 1024 X 768 to provide you with a flicker free display at much brightness. You can also use the 9070 with IBM PS/2 or VGA compatible boards at a high resolution mode like 800 X 600 and 1024 X 768 (non-interlace). The FLEXSCAN 9070 provides a 16-inch screen, large enough for CAD/CAE and 3-D projections, yet small enough to fit comfortably into your home work space.



1024 dots X 768 lines Graphics (Non-interlace)
AutoCAD



Also, for your convenience, all controls and switches, including the alternate video input, are located within easy reach on the front panel. The FLEXSCAN 9070 is compatible with a wide range of IBM, Apple, and other products, allow you to use all of today's popular programs---at a resolution that looks like a million.

FLEXSCAN™ MODEL 9070S

- IBM VGA(PS/2), 8514/A, PGC, EGA compatible and CAD/CAE use.
- Apple Mac. II and SuperMac Spectrum compatible
- Max. 1280 dots X 800 lines high resolution
- 1024 dots X 768 lines display on Non-Interlace signal delivers flicker-free high-res graphics
- 20kHz to 50kHz horizontal scan automatic adjustment. 50Hz to 80Hz vertical scan automatic adjustment
- 16 inch, 0.31mm dot pitch and newly developed XF(Extended Field) Gun to obtain both brightness and sharp focus.
- Front mounted controls including the input signal select switch between 2 video input.
- Selecting white or Amber displays colored application in shades of gray or amber
- Tilt-Swivel stand standard

Come see us at COMDEX
STATEWIDE MICROELECTRONICS INC.
Booth #1665

NANAO®

NANAO USA CORPORATION
23510 TELO AVE., SUITE 5 TORRANCE, CA 90505
PHONE (213) 325-5202 FAX (213) 530-1679

Specifications are subject to change without notice.

APPLE, Macintosh II are registered trademarks of Apple Computers Inc. ARTIST, ARTIST 1 Plus, ARTIST 10, ARTIST 10/16 are trademarks of Control Systems Inc. IBM, IBM PC, XT, AT and PS/2 are registered trademarks of International Business Machines Corporation. SuperMac is a trademark of SuperMac Technology. SuperEGA HiRes, SuperVGA and SuperVGA HiRes are trademarks of Genoa System Corporation. Orchid Designer VGA, Orchid Designer VGA-2, TurboEGA and TurboVGA are trademarks of Orchid Technology. Paradise VGA Professional Card, Paradise VGA Plus Card and Autoswitch EGA are trademarks of Paradise Systems, Inc. Paradise Systems is a registered trademark of Paradise Systems, Inc. VEGA Deluxe and VEGA VGA are trademarks of Video-seven Inc. Metheus is a registered trademark of Metheus Corporation. Imagraph is a trademark of Imagraph Corporation. AutoCAD is a registered trademark of Autodesk Inc. GEM is a registered trademark of Digital Research Inc. Lotus and 1-2-3 are registered trademarks of Lotus Development Corporation. SigmaVGA and SigmaEGA are trademarks of Sigma designs, Inc. FLEXSCAN is a trademark of NANAO CORPORATION. NANAO is a registered trademark of NANAO CORPORATION.

The RenderMan Interface

Tony Apodaca

*Today's
state-of-the-art
image synthesis
will be on your
desktop tomorrow*

What do the following people have in common: an architect developing plans for a futuristic motel complex, a physicist studying vortex flow in the storms of Jupiter, and a special-effects animator merging his robot characters with live-action footage? The answer: They and many others will soon be generating photorealistic computer graphics images on sophisticated graphics PCs and workstations.

The computer industry has seen a fantastic increase in the speed and complexity of computer graphics hardware systems over the past decade. Many graphics workstations can generate, in real time, wire-frame and simple shaded-surface graphics that would have taken minutes or hours to compute only a few years ago. Personal computers have evolved from toys that displayed text in eight colors to respected machines with high-resolution, full-color graphics.

In parallel, the state of the art in computer graphics research has brought users to the threshold of photorealism in synthetic-image generation. As evidenced

by the pictures and films shown at SIGGRAPH and other computer graphics shows, the advent of ray tracing and other sophisticated algorithms, coupled with the powerful computers now available, has made it possible to generate synthetic images that can almost pass for the real thing (see photos 1 and 2).

Unfortunately, these two worlds have remained separate. Fast graphics hardware runs simple algorithms and gener-

ates simple-looking images. Photorealistic-image synthesis software runs slowly on large, expensive computers.

It is time for these two worlds to merge. Users will soon demand photorealism on the desktop. Image synthesis will become a standard workstation and personal computer tool, just as desktop publishing has become standard. This new world will need an interface specification that handles high-quality three-dimensional graphics as elegantly as PostScript handles high-quality two-dimensional page layout. RenderMan is such a specification.

What Is RenderMan?

RenderMan is an interface between three-dimensional geometric modeling systems and photorealistic rendering systems (see the text box "The Quest for Photorealism" on page 270). *Geometric modeling* is the process of describing the shapes of objects and the geometric relationships present within a scene. *Rendering* is the process of generating an image

continued

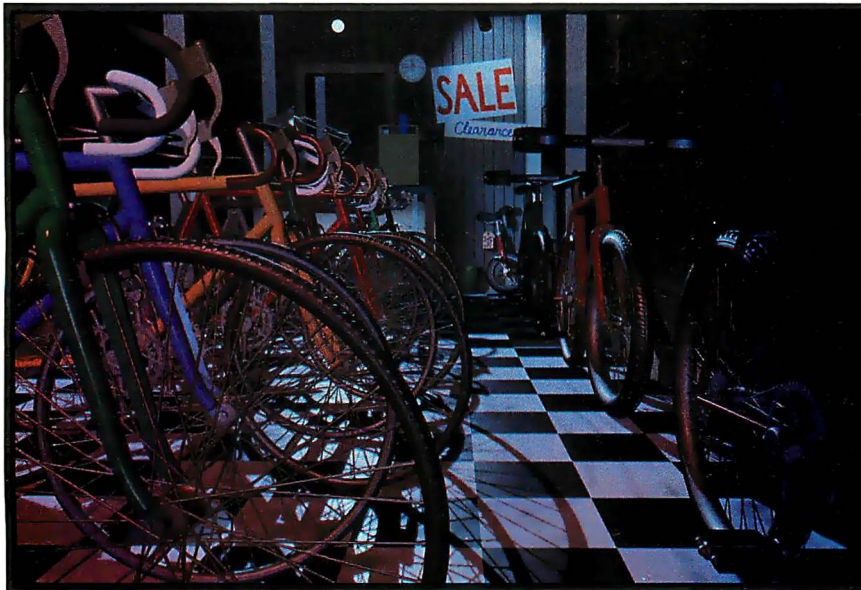

Photo 1: This computer-generated image of a bike store interior contains thousands of objects, dozens of texture maps, and spotlights with shadows.

of the scene from a given viewpoint. RenderMan is an interchange standard that permits a variety of geometric modelers to talk to a variety of renderers with a straightforward, common format.

At the same time, RenderMan defines the state of the art in image synthesis. It represents a design goal for the next generation of graphics hardware.

Most current modeling systems and rendering systems are tightly integrated. The companies that supply geometric modelers also supply renderers. The two communicate through a proprietary database or interface.

Users who want to mix and match the best modeler with the best renderer or who want to write their own programs to generate three-dimensional databases and render them are usually out of luck. The interchange standards that do exist (e.g., IGES, Initial Graphics Exchange Specification) address the problems of exchanging geometric databases from one CAD system to another and do not generally provide the additional information that high-end renderers need, such as camera parameters and color and material properties.

Graphics standards have a long history (see the text box "A Brief History of Graphics Standards" on page 272), but the RenderMan specification is different in one major respect. Previous standards generally attempted to capture, in a device-independent library, the capabilities present in the popular graphics hardware of the time. The lengthy standardization process has almost always ensured that by the time a standard is approved and available, the capabilities of graphics hardware will have progressed beyond it.

RenderMan attacks this problem by capturing the state of the art in high-quality image synthesis research and in-

corporating features and capabilities far beyond those of current graphics hardware. This should help to keep RenderMan viable for many years to come; as hardware improves, an interface will already exist to exploit its power. Modeling companies and users who support the RenderMan interface will have access to new generations of equipment.

The RenderMan interface is a specification for a subroutine library that provides about 100 routines with which a

program the shading in a RenderMan renderer gives you tremendously powerful tools in your quest for photorealism.

The RenderMan interface defines only the content and format of the information that modelers pass to renderers. It attempts to be complete, so that any information a renderer might want to get from a modeler can be accommodated.

However, it does not specify how the renderer should be implemented or what the renderer should do with information once it gets it. Thus, you can use RenderMan as an interface to a wide variety of rendering systems with widely varying algorithms, performance characteristics, and hardware assistance—algorithms from hardware polygon pipelines to ray tracers and beyond are all supported. Any features that tailored the standard to a specific style or speed of rendering were removed.

In addition, high-end features whose visible effects are hard to implement were defined but made optional so that simpler renderers that could not handle them could still meet the interface. Thus, as computer speeds increase, rendering software and hardware running on workstations and personal computers will have a clear road map for increasing their sophistication from simple polygon painting to photorealistic image synthesis.

Geometric Information

The RenderMan interface supports a rich variety of geometric primitives, including convex polygons, concave polygons (with and without holes), and polyhedral models, and it has a general interface for specification of the data that is present at the vertices of a polygon. You can specify not only the position, but also surface color, surface normals, and texture map coordinates on a per-vertex basis. In addition, you can extend the vertex structure at run time to include arbitrary information of your choosing, such as temperature, density, or any other values that might be interesting to your particular application.

RenderMan also supports a large number of quadric surfaces, including spheres, cylinders, cones, hyperboloids, paraboloids, disks, and tori. Each quadric primitive can be fully or partially swept in each direction, so you can easily make hemispheres and pie wedges.

In addition, RenderMan supports a comprehensive bicubic patch primitive. Bicubic patches are curved surfaces that you can think of as the geometric modeling equivalent of rubber sheets. They have many useful properties for model-

continued

Users
*who want to mix and
 match the best modeler
 with the best renderer
 are usually out of luck.*

modeler can describe all the information that a renderer might need to generate an image of a scene.

It provides entry points for geometric information, transformation hierarchies, color and material property information, camera parameters, and output image characteristics. The RenderMan interface subroutines are designed in a way that makes the interface easily extensible. In addition, RenderMan provides a programming language (the shading language) you can use to write small programs that describe the material properties of objects in their scenes. This ability to extend the interface and pro-

Photo 2: *This picture is one of the first computer-generated images to actually pass as a real photograph.*



MAX-VGA™ adapter works with flying colors



providing VGA® compatibility equal to IBM's own VGA adapter

with features that make MAX-VGA unequalled by any other VGA adapter

- Operates up to 400% faster than IBM VGA adapter
- Extended modes (require 512K of RAM): 1024x768 – 16 colors; 640x480 – 256 colors
- Full BIOS and REGISTER compatibility with MDA®, CGA®, MCGA®, EGA®, VGA® and Hercules®
- Works with either XT™ or AT®: 16 bit design – auto-detects and adapts to 8 bit slots
- High-res drivers for popular software

For more information about Maxon's new MAX-VGA adapter, phone (415) 377-0269, FAX (415) 377-0236 or write to Maxon Systems, Inc., 353-B Vintage Park Drive, Foster City, CA 94404.

VGA COMPATIBILITY EVALUATION SUITE

– PC TECH JOURNAL® (November, 1988 issue)

VGA ADAPTERS	TESTS PASSED	TESTS FAILED
IBM® VGA	1-12, 14-18	13*
MAX-VGA™	1-12, 14-18	13*
ATI® VGA WONDER™	1-5, 7, 9-12, 15, 17, 18	6, 8, 13*, 14, 16
VIDEOSEVEN® FASTWRITE VGA™	1-5, 7-12, 15-18	6, 13*, 14
PARADISE™ VGA PROFESSIONAL™	1-11, 14-18	12, 13*

maxon®

SYSTEMS INCORPORATED

A Wholly Owned Subsidiary of Maxon Electronics Co. Ltd. of Korea

The following are tradenames or registered tradenames of the companies listed: IBM, XT, AT, VGA, MDA, CGA, MCGA and EGA – International Business Machines Corporation; Hercules – Hercules Computer Technology, Inc.; VGA Wonder – ATI Technologies, Inc.; FastWrite VGA – Video Seven Inc.; VGA Professional – Paradise Systems, Inc.; MAX-VGA – Maxon Systems, Inc.; and PC TECH JOURNAL – Ziff Communications Company.

*Refers to "Hardware General Register" – reserved control registers and vertical interrupt do not affect operation as seen by applications programs.

Circle 167 on Reader Service Card (DEALERS: 168)

© 1989 – Maxon Systems, Incorporated

The Quest for Photorealism

The first three-dimensional computer graphics systems drew objects as sets of green glowing lines on video display tubes—the familiar *wire-frame drawings* (see photo A). In the 1970s, raster displays progressed to the point where they could be used to draw (or render) objects with sets of colored polygons. The colors were crude, as was the precision of the approximations, but the hidden-surface elimination problem was quickly solved—polygons at the back of an object (usually) didn't show through polygons in the front of the object.

Early systems approximated the effect of a light source on an object by appealing to simple physical laws of diffuse reflection, taking into account how the angle of view and the direction to the light affected the apparent color (the *shade*) of an object at different points on its surface.

In 1971, Henri Gouraud, at the University of Utah, developed an algorithm to smooth out the sharp color changes that happened between adjacent polygons by *interpolating* the colors of the interiors of polygons using the known colors at their corners.

Gouraud's work was followed, in 1975, by that of Bui-Tong Phong. Also working at the University of Utah, Phong developed both a better model for approximating the physics of light and a better way to do interpolation on a polygon, and he gave us the familiar plastic-looking objects that even today are the most common in computer graphics. (It is interesting to note that at this point in 1988 most high-end graphics hardware implements algorithms that are no more complicated than the ones mentioned so far.)



Photo A: Four light bulbs illustrate the evolution of computer graphics: (clockwise from top left) Gouraud-shaded polygons; wire-frame drawing; Phong-shaded curved primitives with texture; multiple texture and displacement mapping with transparency and shading language.

About the same time, other researchers (many at the University of Utah) were developing techniques for rendering curved surfaces directly, rather than approximating them with flat polygons. Ed Catmull (then at Utah, now at Pixar) developed a technique for coloring the surface of an object using the pixels of an image to make it look more interesting—*texture mapping*.

In the late 1970s, *antialiasing*—removing the visible stair-steps (jaggies)

that occur when images are computed with too little resolution or too few colors—was developed. Jim Blinn, of CalTech's Jet Propulsion Laboratory, improved texture mapping to model bumps on surfaces, and the first attempts at simulating shadows were made.

By 1980, Turner Whitted (now at the University of North Carolina) had improved the shading calculation by adding a more accurate simulation of optics, modeling the way rays of light bounced off reflective surfaces and traveled through refractive surfaces, and thereby gave us the ray tracer. In 1984, researchers at Cornell University solved electromagnetic equilibrium equations as a means of understanding how light bounces off every object in a room.

Meanwhile, Rob Cook (at Pixar) decided that it was impractical for any single shading model to describe the wide variety of subtle lighting effects he wanted and wrote the first shading language to give users more control over how a renderer chooses colors for objects. Many researchers simultaneously attacked the problems of depth of field and motion blur to more accurately model the characteristics of a real camera. Others refined the techniques of using random noise as a source of geometric and texturing complexity to simulate natural phenomena.

The art of photorealistic image synthesis has now reached the point where synthetic images can almost pass as real photographs. The key remaining issues revolve around image complexity (the number and variety of objects in real scenes, and the subtlety of the lighting and shading that happens on them).

ing and rendering. One of these is that you can join several patches to each other smoothly without causing the visible bends or creases that polygons would have (i.e., they can be made to be continuous).

If you work with bicubic patches, you'll be pleased to discover that RenderMan supports bicubics with Bézier, B-spline, Hermite, and Catmull-Rom formulations. In fact, RenderMan lets you specify an arbitrary basis matrix, the

mathematical construct that determines precisely how the surface is constructed from the patch data points. RenderMan also supports nonuniform rational B-spline surfaces (NURBS), curved-surface primitives that are all the rage in automotive design circles these days.

RenderMan is the first graphics interface to support procedural primitives. One of the biggest problems in modeling natural phenomena (e.g., mountains, plants, fire, and so on) is that the geo-

metric complexity is enormous.

This problem is usually solved by writing programs that generate all the tiny detail rather than modeling it by hand. However, it can still be very expensive for the modeler to generate a huge complex model and pass it to the renderer, particularly if the modeler doesn't know how much of it the renderer really needs.

RenderMan's procedural primitives
continued

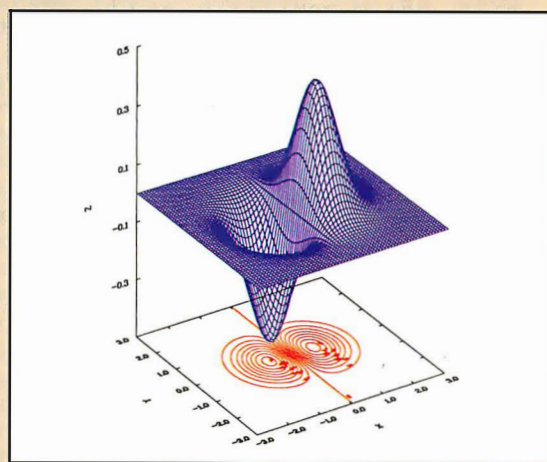
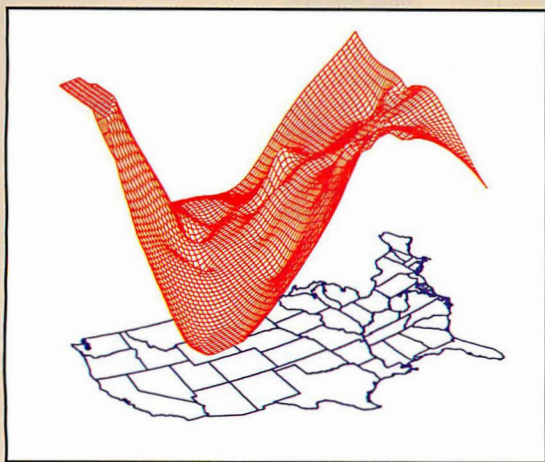
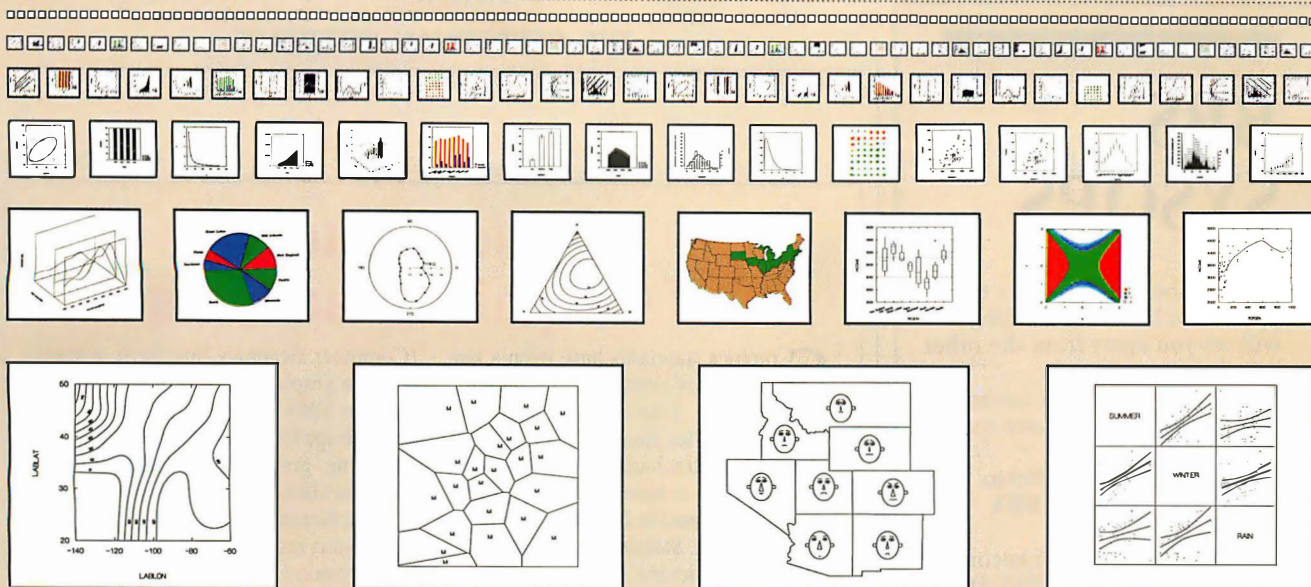

If a picture is worth a thousand words, what are a thousand pictures worth?

Sygraph has more technical graphics than any other PC or mainframe package.

If you already use a technical graphics package, you probably have been frustrated to find that it cannot produce the sophisticated graphs you need for presentation or publication. You want asymmetrical error bars, but it draws only symmetric. You want logs to any base, but it does only base 10. You want contouring over irregularly spaced data points with several different smoothers, but it contours only over regular grids.

Sygraph was developed for the scientist. Text can be infinitely sized and angled in two or three dimensions. Composite 3-D graphs can be produced with a surprisingly simple set of commands. And unlike "paint" programs, it can process programmable macros to produce customized graphs for similar applications on different data.

Sygraph interfaces to popular microcomputer file formats and it includes drivers for over 50 color boards, plotters, printers, cameras and other graphic devices. If you use a spreadsheet, a data base, or a statistics package like SYSTAT, SAS or SPSS, now you can produce the graphics worthy of your research.

Sygraph operates on IBM PCs and compatibles. Single copy price \$495. Site licenses, quantity prices and training seminars available. No fees for technical support.

SYSTAT, SAS and SPSS are registered trademarks of SYSTAT, Inc., SAS Institute Inc. and SPSS Inc., respectively.

- Features:** Overlay plots Drivers for most graphics devices *Two-dimensional:* Error Bars Scatterplots Line and Vector Graphs Vector, Dot, Bubble and Quantile Plots Bar Graphs (single, multiple, stacked, range) Box plots (single and grouped) Stem-and-leaf diagrams Linear, quadratic, step, spline, polynomial. LOWESS, exponential smoothing Confidence Intervals and ellipsoids (any alpha value) Smooth mathematical functions Rectangular or polar coordinates Log and power scales ANOVA interaction plots Histograms (regular, cumulative, fuzzy) Stripe and jitter plots Gaussian histogram smoothing Scatterplot matrices Voronoi Tesselations Minimum spanning tree Maps with geographic projections (U.S. state boundary file included) Chernoff faces Star plots Fourier plots Pie charts Contour plots on regularly and irregularly spaced points Control charts and limits *Three-dimensional:* Data plots Smooth function plots Vector plots Linear, quadratic, spline, least squares surface smoothing Three-dimensional type fonts Import/export Lotus, dBase, and DIF files Full screen data editor



For more information, call 312 864.5670 or write Systat, Inc., 1800 Sherman Avenue, Evanston, IL 60201. FAX 312.492.3567.

BBS SYSOPS

Are you looking for ways to improve your board? Something that will set you apart from the other boards in your area?

Are your subscribers interested in Microcomputers? Listen to this!

Announcing the Bulletin Board EXchange — BBX

The BBX allows you to become a publisher of MicroBYTES Daily, an on-line news service from BYTE. BBX/MicroBYTES is a custom package of news and features designed specially for local BBSes, and is available only to sysops.

Every Monday through Friday you get articles about developments in microcomputing, telecommunications and selected new product announcements. Get the latest news MSDOS machines, Macintosh, Unix workstations, peripherals and software. All the stories are reported, written and edited by the staff of BYTE Magazine, BYTEweek and BIX. With BBX/MicroBYTES your board will have access to our world-wide network of reporters and editors.

Not only do you get a great resource for your subscribers, but you also get access to BIX which will cut your cost of exchanging information and conducting BBS network business.

All this is only \$199 per year. If you call BIX directly you pay no hourly rates. If you call using Tymnet the rates are only \$2/hr on evenings and weekends and \$8/hr on weekdays.

See our ad on pages 290, 291 of this issue.
Subscribe today.

BIX

One Phoenix Mill Lane
Peterborough, NH 03458
1-800-227-2983
In NH (603) 924-7681

A Brief History of Graphics Standards

Graphics standards have been a key element of computer graphics for over a decade. Like all standardization efforts, graphics standards come about because vendors and users realize that their industry is hampered by a profusion of incompatible hardware and software systems. Standards promote portability and device independence for applications software, important qualities in the fast-changing computer industry.

The earliest proposals for graphics standards, Core (1977) and GKS (Graphical Kernel System, 1978), were developed to solve the need for two-dimensional output. They dealt with primitives such as lines, markers, and polygons filled with crosshatch patterns or color. They also had reasonably extensive text capabilities and handled interactive input from several devices.

More recently, the need to produce three-dimensional drawings has been addressed by a standard called PHIGS (Programmer's Hierarchical Graphics System, 1984). This standard addressed three-dimensional lines, markers, polygons, and text, and added the notion of a hierarchical model, which allowed users to manipulate the graphical database (e.g., rotate it in three dimensions, modify the colors, and so on) without having to respecify the entire database from scratch.

Associated with each of these graphics standards has been a series of related proposals to extend their functionality to new situations. GKS spawned CGI

(Computer Graphics Interface), a standard for graphics devices that would implement GKS efficiently; CGM (Computer Graphics Metafile), a standard for archiving graphical descriptions in a file; and GKS-3D, an extension of GKS to three dimensions that rivaled PHIGS. PHIGS has recently spawned PHIGS+, an extension to include hidden-line and hidden-surface elimination and simple light sources.

Each standard has been developed through the deliberations of a number of standards bodies such as ACM SIGGRAPH, ANSI, and the International Standards Organization. The trip through the standards pipeline is long—GKS was finally approved as an international standard in 1984, and a C language binding (a formal list of the official C subroutine calls) was finally approved last year.

Graphics standards can also result from industry acceptance of a clean and powerful interface proposed by a single company or group of cooperating companies. De facto standards such as PLOT-10 (a two-dimensional plotting package), X (a window management package), and PostScript (Adobe's page-layout language) have emerged in this way. De facto standards are developed and refined more quickly than official standards, particularly since there is a guarantee that a conforming implementation is available; however, the fact that they are not official sometimes limits their acceptance among competing companies.

permit you to give the renderer a pointer to a subroutine that will expand simple objects into more complicated ones, such as converting a triangle into a fractal mountain or a sphere into a particle system explosion. Using procedural primitives, the modeler can download a very complex model, such as a fractal, to the renderer in a carefully controlled way that sends only the required amount of detail through the interface.

No three-dimensional rendering interface would be complete without hierarchical modeling, and of course RenderMan supports it. There is a full set of transformation operations (e.g., rotate, translate, scale, and skew), which can be

pushed onto, and popped from, a hierarchical transformation stack. This permits modelers to easily define articulated models (e.g., a robot), where the position of one piece depends upon the position of another piece further along. Constructive solid geometry, a technique for defining objects in terms of the sums and differences of solids (e.g., a solid block with a cylindrical hole cut out of it), is also fully supported.

Shading Information

RenderMan has a large set of routines for defining shading information. You can set both the color and the opacity of objects, and you can specify colors not

NRI's new at-home training gives you the computer, the software, and the hands-on skills to start a high-paying career as a computer programmer

Now NRI gives you hands-on experience in computer programming with a powerful IBM-compatible computer system and software you keep. One easy step at a time, you build full-featured, powerful programs in BASIC, Pascal, C, and COBOL—today's hottest computer languages. One easy step at a time, you train to be a high-paid computer programmer!

Your NRI training includes a computer, modem, and invaluable programming software you keep

Unlike any other course, NRI's at-home training in Computer Programming gives you hands-on experience with a powerful, IBM-compatible Packard Bell VX88 computer system, including 2400 baud internal modem, 512K RAM, disk drive, and invaluable programming software—BASIC, Pascal, C, and COBOL—all yours to keep.

With NRI, you get the skills and the confidence, the computer and the software to build real-world, working programs for a wide variety of business, personal, and professional applications . . . in all, everything you need to step into today's top computer programming jobs.

No previous experience necessary

No matter what your background, NRI ensures you get the know-how you need to take full advantage of every exciting opportunity in computer programming today.

With your experienced NRI instructor always available to help, you quickly cover the fundamentals, then

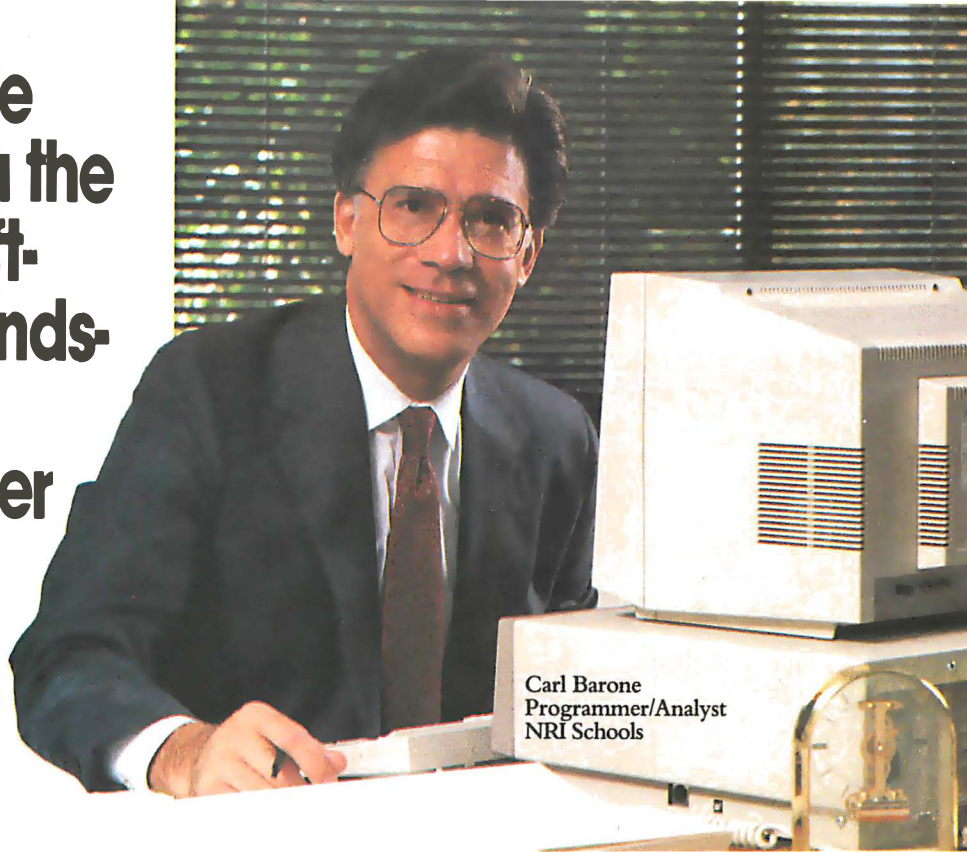

Carl Barone
Programmer/Analyst
NRI Schools

move on to master all four of today's key computer languages—BASIC, Pascal, C, and COBOL—step by easy step. Before you know it, you have what it takes to handle any programming problem you're likely to encounter in your professional career.

Now, as never before, you can succeed as a computer programmer

The best news comes from the Bureau of Labor Statistics: As a programmer trained in a variety of computer languages you

can land the programming position of your choice—even make it on your own as an independent programmer. There's no doubt about it—with NRI's complete, at-home, four-language training in Computer Programming, you can write your own ticket to success in this high-paying, top-growth computer career field!

See other side for highlights of your NRI hands-on training in BASIC, Pascal, C, and COBOL →

SEND CARD TODAY FOR FREE NRI CATALOG

YES! Please rush me my FREE catalog describing NRI's at-home training in Computer Programming.

Name _____ Age _____
(please print)

Address _____

City _____ State _____ Zip _____
5401-049

Your NRI training in computer programming includes an IBM-compatible Packard Bell VX88 computer with internal modem, 512K RAM, disk drive, monitor, and programming software—BASIC, Pascal, C, and COBOL—all yours to keep!



Now, with NRI, you can learn to program in today's hottest computer languages— BASIC, Pascal, C, and COBOL



You start with BASIC, an extremely popular language used for graphics, teaching, personal, and small business applications.

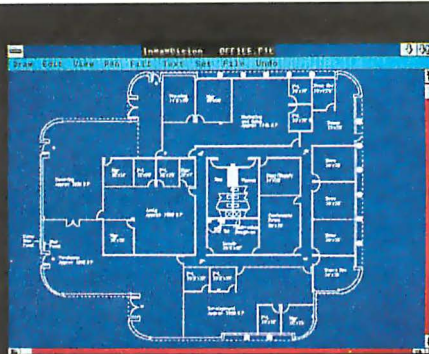

Next, you master Pascal, a multipurpose language often used to develop software for computer-aided design (CAD).

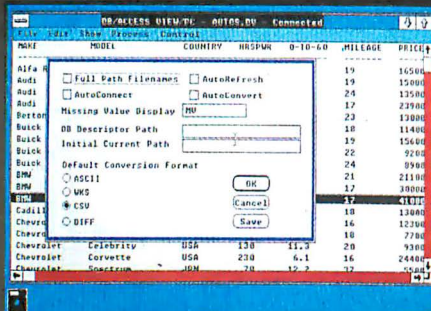

You move on to C—hands down, today's hottest computer language—used for everything from systems programming to artificial intelligence.

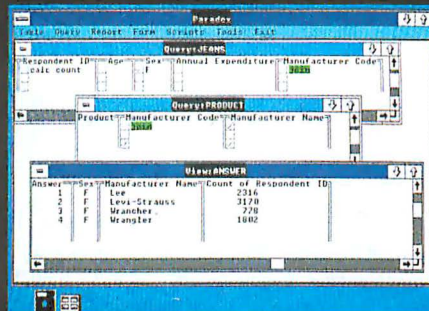

You wrap up your training in programming with COBOL, the language of business and the most widely used computer language in the world.

NRI's new at-home training in Computer Programming starts by walking you step by step through the fundamentals, easing you into programming with brilliantly detailed instructions, charts, and diagrams.

In no time at all, you have a complete understanding of the programming techniques used every day by successful micro and main-frame programmers. And then the fun really begins.

With your personal NRI instructor on call and ready to help, you use the computer system included in your training to actually design, code, run, debug, and document programs in BASIC, Pascal, C, and COBOL. Then, following easy-to-read instructions, you use your modem—also included—to “talk” to your instructor, meet other NRI students, even download programs through NRI's exclusive programmers network, PRONET.

Send for your FREE catalog today

For all the details about NRI's at-home training in Computer Programming, send the postage-paid reply card today. Soon you'll receive NRI's fascinating, information-packed, full-color catalog.

Open it up and you'll find vivid descriptions of every aspect of NRI training. You'll see the IBM-compatible Packard Bell computer included in your course up close in a special, poster-sized foldout section. And, best of all, you'll find out how your NRI training will make it easy for you to build a high-paying career—even a business of your own—in computer programming.

If the card is missing, write to NRI at the address below.

IBM is a registered trademark of the IBM Corporation

SEND CARD TODAY FOR FREE NRI CATALOG

BUSINESS REPLY MAIL

FIRST CLASS MAIL PERMIT NO. 10008 WASHINGTON, D.C.

POSTAGE WILL BE PAID BY ADDRESSEE

NRI SCHOOLS

McGraw-Hill Continuing Education Center

3939 Wisconsin Avenue

Washington, D.C. 20077-9265

NO POSTAGE
NECESSARY
IF MAILED
IN THE
UNITED STATES

NRI
School of Computer Programming

McGraw-Hill Continuing Education Center
3939 Wisconsin Avenue
Washington, DC 20016



merely in the RGB coordinates typically used in computer graphics, but also in multichannel spectral colors if the need arises. The use of spectral color permits renderers to more carefully compute the ways in which some objects reflect and refract light at different wavelengths (e.g., a prism).

One of the most important features of the RenderMan interface is its strong support for user-definable material characteristics. You can define up to four separate shading language programs that provide different material characteristic information about each object: a *surface shader*, which determines what color you see when light reflects off the surface; a *displacement shader*, which can move the surface by small amounts to add dents or fillets that are too small or too complex to model geometrically; a *light shader*, which describes how luminous objects emit light; and a *volume shader*, which describes how light is attenuated as it passes through the interior of a translucent object.

While this may seem complicated, it's actually a straightforward way to think about the material properties of objects, particularly once you've seen these shaders in action.

Special Effects

You specify the camera position and orientation using the same hierarchical transformations that describe the positions of all the other objects in the scene. RenderMan lets you specify other parameters of the simulated camera, as well, in order to provide information to renderers that support advanced rendering features.

For example, you can set the shutter time as well as the focal length, focal distance, and f-stop of the camera to simulate motion blur and depth of field. Photography buffs will recognize motion blur as the effect that occurs when a fast object moves across the camera's field of view during the interval that the shutter is open (see photo 2).

RenderMan lets you specify the positions, shapes, and colors of the objects at multiple times during the shutter interval. This is so that sophisticated renderers that can simulate motion blur will know how the objects are moving.

High-quality rendering requires a lot of attention to the sampling and filtering that are performed on the output pixels in order to avoid *aliasing*—the "jaggies." RenderMan offers independent control over the number of shading samples per pixel and the number of hidden-surface samples per pixel, as well as the size and

shape of the pixel filter function.

Besides the standard display parameters of output image name, device type, and resolution, RenderMan supports gamma correction and exposure control. These functions compensate for the tendency of a monitor's phosphors to glow with exponentially increasing brightness as voltage increases linearly. RenderMan also contains the new concept of an *image shader*, another shading language program that lets you implement various

color manipulations on final pixels just before they are put into the frame buffer or file.

Shading Language

I've mentioned the RenderMan shading language several times. Now I want to take a close look at it. Most renderers have a subroutine that determines the color of the surface of an object. Typically, this subroutine implements a single

continued

GRAPHICS FOR MAC II®

AND IBM®

miroGRAPH

Flickertree Display
72 dpi and 75 Hz refresh rate are the common features of these boards. You can choose: 256 colors, 256 greyscales or black and white. Compatible with any software based on the Apple Color Quick Draw.

Highest Resolutions
miroGRAPH graphics boards for PC/ AT and PS/2 are featuring resolutions of 1024 x 768, 1280 x 1024 or 1600 x 1200. Drivers for major software products are supplied with our boards. Ask for our actual compatibility list.

USA: miro, 27758 Santa Margarita Pkwy., Suite 285, Mission Viejo, Ca 92691, Phone 1-714-380-1120, Fax 1-714-5822873
 Germany: miro, Gilhomer Str. 28, 3300 Braunschweig, Phone: 49-531-30091-0, Fax 49-531-30091-99, Apple Link GER.XSE0012

mathematical equation that uses a simple model of the reflection of light to calculate the contributions of the light sources and texture maps to the surface color.

The equation often has many parameters (5 to 20, depending on the renderer) that you tweak to control the appearance of different kinds of materials (e.g., plastic, metal, and chalk). Very often, however, you want the surface to have some characteristic you can't achieve with the fixed equation, and you want to

use a texture map to modify some parameter that the implementers didn't think you would want to modify. What can you do?

If you are fortunate enough to have the source code, you can add your function and recompile. If not, you are out of luck. RenderMan changes this situation. It provides the shading language, a C-like programming language that has new functions and data types designed to calculate colors based on geometric infor-

mation. Programs that you write in the shading language are typically small (10 to 20 lines) and are loaded into the renderer at run time when they are requested by some part of the scene geometry.

These programs then replace the built-in shading equations. You can use this language to customize shading on a per-object basis. This new freedom gives you the power to model the appearance of objects as carefully as you model their shapes.

The shading language supports three basic data types, the float, the point, and the color. Point and color are abstract data types that are actually vectors of length three (color can have more than three components when spectral color is enabled). The standard C arithmetic operators (*, +, /, etc.) work on these data types. In addition, there are some new operators for vector dot and cross product.

The familiar C conditional and looping constructs are available (except switch), as are subroutine definitions and calls. There is a rich library of mathematical functions, as well as a library of functions that implement common shading operations such as normalizing vectors, transforming points between coordinate systems, calculating diffuse and specular lighting, interpolating colors, splining, and calculating pseudorandom numbers.

The renderer calls the appropriate shading language program (the shader) every time it requires a light intensity, surface color, and so on. When a shader is called, it has access to a large number of global variables that the renderer provides. These variables include all the geometric information that the renderer knows about the surface being shaded, such as the position P; the surface normal N; the color Cs and opacity Os that you specified; the texture coordinates s,t; and others. The variables that you applied to the vertices of your primitives are also available inside the shaders.

Each type of shader accomplishes its specified task by calculating and modifying a specific part of this global state. For example, a surface shader is responsible for calculating and setting C_i, the color that the eye sees. A light shader is responsible for setting C_l, the light color.

Listing 1 is an example of a basic surface shader. Using a simple equation, this shader calculates the reflectivity of a metallic object. It uses the standard library functions ambient, diffuse, and specular to determine the amount of light arriving on the surface from the light sources.

TRY THIS ON A STANDARD DESKTOP PUBLISHING SYSTEM

$$\int_{-\infty}^n \frac{Xy \cdot Z dt}{X - tY} = \sum_{i=1}^n \left(\frac{(x^4 - i)^3}{\sqrt{Z^3 + y^{10}}} \right) \frac{1}{Z - X^5 Y}$$

For professional looking mathematical formulation, tables and scientific notation—no matter how complex—PCTeX is unequalled. That's why many university engineering departments and scientific societies now require papers for publication be submitted in TeX. In the world of desktop publishing systems, INFOWORLD rated PCTeX #1, saying: "...No non-TeX-based program has such a comprehensive built-in grasp of typological aesthetics..."

And from PC MAGAZINE: "...You can achieve incredible precision in formatting text, especially mathematical expressions."

WHEN YOU ADD PCTeX, COUNT ON MORE THAN PRETTY NUMBERS.

TYPESET & MANUALS, FORMULAS & TABLES

in the same **FORMAT** as **DIFFERENT** ONES

BIG OR SMALL

WIDE OR NARROW LIGHT OR BOLD

IT'S NICE TO KNOW PCTeX WON'T LIMIT YOUR IMAGINATION.

Finished with the formula? Then try this formatting exercise on a standard desktop system. All positioning, sizing and typesetting are done with PCTeX—no more cut'n'paste.

INFOWORLD again: "...Enormously flexible and offers complete control over the output of your printer."

And with Bitstream's 30+ font families, any type of type you like is easy as **A, b, c**

PCTeX = the professional camera-ready, publisher-ready manuscripts you want.

PCTeX SUBTRACTS TIME FROM AUTHOR TO PRINTED PIECE, MULTIPLIES AUTHOR CONTROL.

For a free PCTeX demo diskette, the new PCTeX 88 product catalog and information on a PCTeX configuration for your system, give us a call at **415-388-8853**



12 Madrona Ave. Mill Valley CA 94941

PCTeX is a registered TM of Personal TeX, Inc. TeX is an American Mathematical Society TM. Manufacturer's product names are their TMs. Inquire about PTI distributorships. Site licenses available to qualified organizations. This ad was typeset using PCTeX and Bitstream fonts.

THE RENDERMAN INTERFACE

Listing 1: A simple shader that simulates the reflection of light off metallic objects.

```
surface metallic (float Ka=.4, Kd=.4, Ks=.6,
    roughness=.25){
    N=faceforward(normalize(N));
    Ci=Ci * (Ka*ambient() + Kd*diffuse(N)
    + Ks*specular(N, -normalize(I), roughness) );
}
```

Listing 2: A shader that simulates wire mesh by varying the opacity of the object.

```
surface wire_mesh (float Ka=.4, Kd=.4, Ks=.6,
    roughness=.25, nu=2.0, nv=2.0);
{
    if (mod(u*nu, 1.0) > 0.5 && mod(v*nv, 1.0) > 0.5){
        Oi=0.0; /* Transparent! */
    } else {
        Oi=1.0; /* Opaque metal! */
    }
    N=faceforward(normalize(N));
    Ci=Ci * (Ka*ambient() + Kd*diffuse(N)
    + Ks*specular(N, -normalize(I), roughness));
}
```

Listing 3: A shader that simulates dents by moving the surface a small amount. This adds visual complexity that is very difficult to model convincingly using standard geometric modeling techniques.

```
displacement dent (float scale=1.0;){
{
    float size=1.0, displace=0.0;
    for (i=0; i<6; i+=1.0) {
        /* Calculate a simple fractal 1/f noise function */
        displace += abs(.5 - noise(P * size)) / size;
        size *= 2.0;
    }
    /* Displace the surface and recalculate surface normals */
    P += N * pow(displace,3.0) * scale;
    N = calculatenormals(P);
}
```

These functions implement three customary equations based on the direction and strength of the incoming light. If those functions are not appropriate, the surface shader has access to the lights and can calculate whatever values it pleases from them.

The shader then calculates a weighted average of the incoming light intensities and multiplies by the color of the object. Notice also that the shading language automatically takes care of the multiplication of float values by color vectors, freeing you from having to write the ugly loops that would be necessary in most other languages.

The type of shader (in this example, surface) indicates its intended function. Parameters to the shader are specified using a syntax similar to that of ANSI C.

This shader demonstrates another unique feature of the shading language, the presence of default values in the parameter list. When a modeler requests this shader, it specifies by name the parameters it wants to override. Any parameter not mentioned is left with the default value.

You can examine a slightly more complicated shading language function in listing 2. Every geometric primitive has a two-dimensional surface, and renders typically define a simple coordinate system (known as *parametric coordinates*) on this surface in order to apply texture maps and do similar functions that need to vary along the surface. This shading language function uses a bit of tricky arithmetic on the parametric coordinates.

continued

TECH*GRAPH*PAD

Still
trying to get
Engineering
& Scientific
graphs
from a
Business
program?

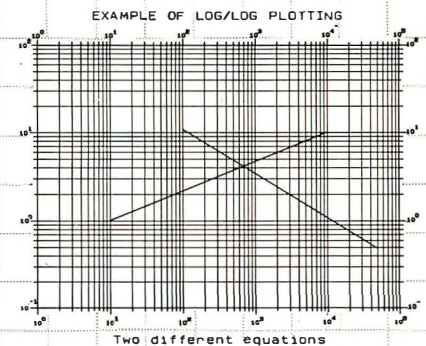
TECH*
GRAPH*
PAD

Easy-to-use technical graphing & plotting software for engineers & scientists. Compatible with Lotus 1-2-3 worksheets, other spreadsheets, PRN & ASCII files, & most data acquisition packages.

Now shipping Version 3.0!

- X-Y, Semi-log, Log/Log, Polar Plots
- Curve Fitting • Data Smoothing
- Labels, Scale, & Color Control
- Multiple X-Y Axes
- Error Bars • Greek Letters
- Laser Printer, Plotter, Printer Output
- IBM PC/XT/AT, PS/2, Apollo, DEC compatible

CALL

(617) 890-1812

Dealer Inquiries Invited

 **binary engineering**

100 Fifth Ave., Waltham, MA 02154

Photo 3: The lead toy demonstrates the metallic and dent shaders, the golden toy demonstrates the wire-mesh shader, and the large toy uses a similar shader reminiscent of wire-frame drawings.

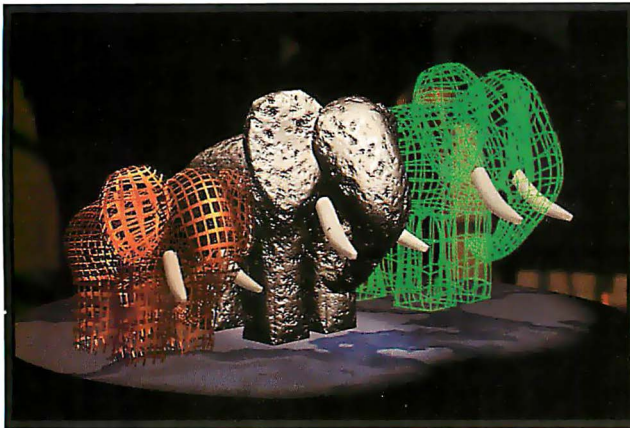

dinates u and v to decide whether to make the surface opaque or transparent at each point. This has the visual appearance of cutting a hole in the object.

Listing 3 illustrates a displacement shader. A displacement shader moves the position of the surface around a little bit to simulate tiny fillets, dents, and other minor surface perturbations. This adds to the visual interest of an object and makes it look more realistic. This particular shader calculates a fractal dentedness using several iterations of *noise*, a function that produces a semirandom

value that changes slowly over the surface of the object (using a purely random value would distort the surface beyond recognition, since adjacent points would have no relationship to each other).

Photo 3 shows the effect of using these shaders on a simple model of a toy. Achieving the same effect by trying to model the individual metal bands or the intricate surface dents would be extremely difficult.

You can see the value of complex shading using texture maps and nontrivial shading-language shaders by comparing

Photo 4: An office floor-plan model with simple shading. (Data courtesy of Autodesk, Inc.)



photos 4 and 5. Photo 4 is a model of the inside of an office, generated using the AutoCAD modeling system and a simple renderer.

Photo 5 is exactly the same geometry file, but the objects were given custom material characteristics using the shading language: There are shadows; several objects have texture maps; there are reflections in the waxed floor and bookshelf; there are subtle displacements implementing fillets on the chair and books. Each of these shaders is a few lines long, and the difference in image quality is astounding.

Wrapping It Up

RenderMan is a powerful interface between three-dimensional modeling systems and photorealistic rendering systems. It represents the first graphics interface to deal with issues in high-quality synthetic-image generation such as antialiasing, texture mapping, motion blur, shadows, spectral color models, and programmable shading languages.

These advanced features are not available on most of the rendering software and hardware currently available. Thus, RenderMan represents a goal for sophisticated new graphics hardware and rendering software to shoot for.

Users of graphics workstations and personal computers will be the biggest winners, as photorealism becomes inexpensive, commonplace, and compatible across a wide range of platforms.

Pixar publicly announced the RenderMan interface last May after over six months of industry review by computer graphics workstation manufacturers, software vendors, and sophisticated end users. At that time, 19 companies endorsed the specification as a common interface to high-quality computer graphics.

Many of these companies are working on products that adhere to the specification, and these products will probably be announced in the next six to 12 months. Once these products appear, it will only be a matter of time before everyone has photorealism on the desktop. ■

Editor's note: Copies of the *RenderMan Interface* version 3.0 are available from Pixar, Inc., 3240 Kerner Blvd., San Rafael, CA, 94901. Please enclose \$15 to cover the cost of printing and mailing.

Tony Apodaca, a software engineer at Pixar, Inc. (San Rafael, CA), has a master's degree in computer and systems engineering from RPI. He can be contacted on BIX/clo "editors."

Photo 5: The same office floor-plan model with custom shaders, textures, and shadows.

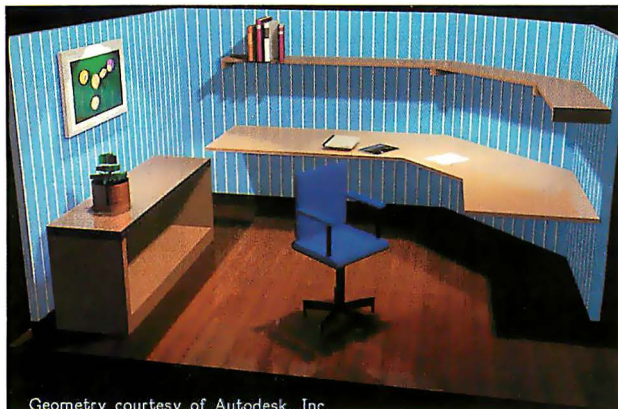

Geometry courtesy of Autodesk, Inc.

Digitizers

18" x 24" thru 9' x 9' x 9'

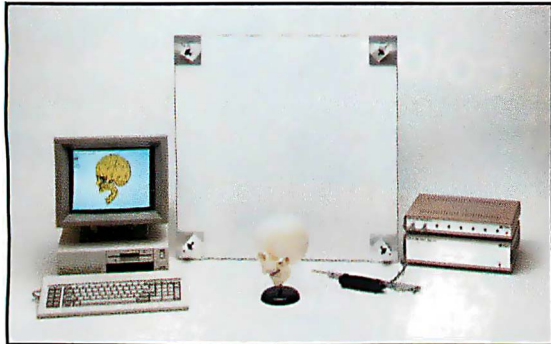

We'll cover your digitizer needs with twelve different active areas to choose from. From the GP-7 Grafbar Mark II, ("Flexible, Precise, and Elegant . . .", PC Magazine), all the way through the 60" x 72" GP-8, and of course the user adjustable active volume, (up to 9 ft. cube), of the GP-8-3D. And you can digitize on any work surface.

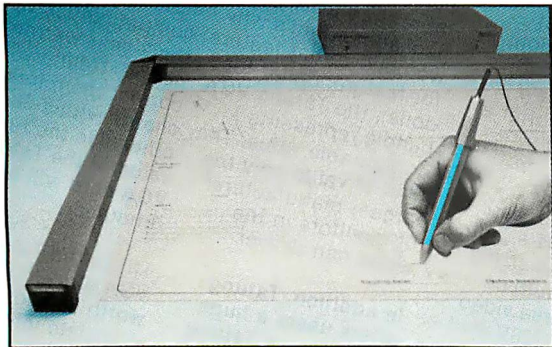

All our digitizers come complete with RS-232 output format, power supply, two-way communications, a stylus, optional one button and four button cursors, a five function menu, and are IBM-PC compatible. So no matter what your size requirements are, we've got you covered; (at low cost too!).

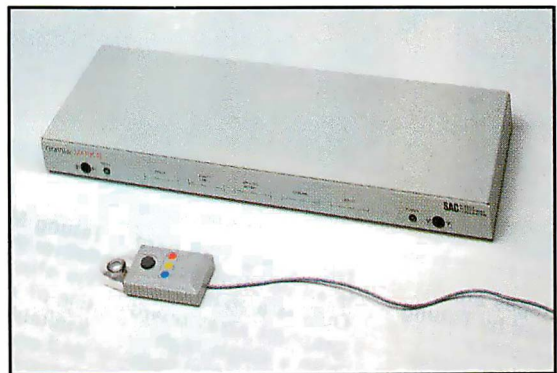

OEM versions available. Directly supported by AutoCAD, ProDesign II, Generic CADD, CADVANCE, CADKEY, Easy Digit, etc. Also, compatible with Lotus Measure.

For more information contact:
Skip Cleveland (203) 255-1526

We've got your size.

SAC[®] SCIENCE
ACCESSORIES
CORPORATION

970 Kings Highway West, P.O. Box 550 Southport, CT 06490 (203) 255-1526 • Telex 964300 FAX (203) 254-7271

**A new way to look at color;
a better way to buy it.**



MM-1233 12" analog monochrome Grey scale MM-1433 14" analog monochrome Grey scale CM-1496 14" analog color 31mm dot pitch CM-1492 14" analog color 39mm dot pitch CM-1296 12" analog color 28mm dot pitch

Advantages are enhanced by Tatung
VGA provides significantly higher resolution. In fact, image clarity is 37% higher than EGA. And while EGA gives you 16 on-screen colors, VGA puts 256 colors (from a palette of 262,144 colors) on a monitor's screen at a time. Distortion, ghosting, and even eye fatigue is sharply reduced. In text modes, characters (even those with descenders like y, p and g) are more clearly defined thanks to a 9 x 16 dot matrix. But, while the monitor is a vital part of a VGA system, we think the real key is the VGA card that goes with it.

The Tatung VGA card is all performance
Ours is a 16-bit graphics array board with a single high speed, register compatible, VGA chip...a graphics controller that's incredibly fast (it has a bandwidth more than 7 times that of other VGA boards)! You can access this speed through the 16-bit data path to display memory, BIOS ROM, and I/O. Our exclusive SwiftWrite makes the wait state virtually non-existent. More? With 16 colors, resolution increases to 800 x 600. On-board is a 256K DRAM; and the card is backward compatible with EGA, CGA, MDA and Hercules graphics standards.

Tatung Monitors deliver the new standard
We offer the broadest line of VGA monitors available; 5 newly styled and engineered monitors. Each model provides 640 x 480, 640 x 350 lines of graphics resolution; 720 x 400 lines for text. Tatung's new VGA monitors offer a broad range of features that contribute to their superior value: dark, non-glare CRT's, automatic vertical sizing encoding, multi-color text or reverse video switch, 110/220V switchable power supply, removable tilt/swivel bases...all supported by Tatung's full year warranty.

Tatung bundles provide superior value
By bundling VGA monitors and cards, Tatung puts VGA within the reach of everyone. In most cases, the Tatung VGA bundle will cost no more than EGA packages! That's why we believe that feature for feature, dollar for dollar, the Tatung VGA bundle represents incomparable value. The kind of value only the largest manufacturer of monitors in the world can deliver.

Tatung offers guaranteed compatibility
Whenever a new standard is introduced, system users have a justifiable concern about software compatibility. That's why **Tatung offers a unique guarantee***: if you note any software incompatibilities within the 1 year warranty period, Tatung will correct them free of charge within 30 days, otherwise the full value of the Tatung VGA card will be refunded.

In addition, Tatung offers users a huge advantage: a Tatung VGA bundle is 100% IBM™ VGA compatible and more...your investment in software is fully protected.

That's the Tatung VGA story. It's a story worth seeing. For complete information, specifications, and the name of the Tatung dealer near you, and to arrange for a demonstration, call us today. After all, seeing is believing.

Circle 276 on Reader Service Card

NOW AVAILABLE!
New TVGA-8, 8-bit card!



TATUNG
We monitor the world.

In Southern California: (213) 979-7055

In Northern California: (408) 435-0140

Outside California: (800) 421-2929

Tatung Company of America, Inc.

2850 El Presidio Street, Long Beach, CA 90810

Tatung Science & Technology, Inc.

2060 Ringwood Ave., San Jose, CA 95131

* Warranty applies to IBM PC, XT, AT Systems and their compatibles. Refer to Tatung VGA Card Manual for specific details. All details included with each Tatung VGA card. All names trademarked are properties of their respective manufacturers.

Interacting with the Tiny and the Immense

Craig Mundie

*Scientific
visualization
lets researchers see
the unseeable*

An important part of scientists' work is to think of ways to represent information so that they and others can understand what's going on. Visual images help scientists develop and share their insights and theories with colleagues, by providing an effective way to pass along the mental images that are the basis of their thoughts. Computer graphics can facilitate the transfer of research results from one scientist to another by generating precise graphical representations to illustrate important points. When the relatively new capability of animation is applied to graphical representations, more insight into the data can be attained.

In this article, I'll describe some of the philosophy and techniques behind scientific visualization and discuss where it's heading. I have included photos that demonstrate the results of scientists' work in several areas.

The Importance of Visualization

Scientists and engineers have long understood the importance of pictures in perceiving and communicating the functional relationships in quantitative data. Graphical devices, such as contour plots, structural diagrams, or ball-and-stick models, have long been familiar tools in sciences such as physics, chemistry, and cartography. And since the early 1960s, scientists have used computers to perform calculations and manipulate the resulting data for output in graphical form on plotters and display terminals. Computers greatly expanded the volume of data that could be handled, and graphical displays eased the chore of understanding data by presenting relationships visually.

The human being's ability to comprehend pictures stems from the fact that over half the brain's neurons are used to process and understand visual input and that the brain's ability to take in this information is enhanced by a visual input data channel with a bandwidth estimated to be about 2 gigabits per second.

Higher-resolution graphics display

terminals now let scientists view data in three dimensions rather than two, extending their capability to understand the data. Three-dimensional color representation provides a global picture of the data—one displayed image can represent 10 million numbers. This gives scientists the ability to see simultaneously all the information that otherwise might have to be printed on reams of paper. This substantially cuts the amount of time required to discover whether or not the data represents a sensible result.

But maximum individual productivity will not be attained until researchers and scientists are able to control not only the display of the images generated but also the computation of data that is used to generate the pictures. The goal of scientific visualization is to give researchers the ability not only to view pictorial representations of the data as they are generated but to promote insight into the meaning of the data by allowing researchers to modify the computational process as it is occurring.

Extending the Capabilities

Scientific visualization extends the capabilities of computer graphics technology by giving researchers better control of the process by providing added levels of functionality. Scientific visualization, the conversion of massive amounts of data into pictures that show the results of computations, moves beyond ordinary simulation techniques. It can be an ani-

ated, interactive process in which scientists can manipulate data and, in real time, see the results of their changes. Under the umbrella of scientific visualization, the previously discrete disciplines of computer graphics, image processing, computer vision, CAD, signal processing, and user interface technology are applied to scientific research.

While the term scientific visualization simply refers to the use of images to interpret scientific data, its most important function is to provide researchers with the means to *interact* with the graphics in such a way that real-time interpretation of data is possible. True interactive visualization offers scientists impressive advantages that include better analysis, improved productivity, and cost savings.

Full-function scientific visualization is now available primarily to groups of researchers who work at supercomputer installations. (See the text box "PCs and Scientific Visualization" on page 280 for a look at the personal computer's future in visualization.) To make the technology more widely available throughout the scientific community, the National Science Foundation is urging implementation of a federally funded initiative in the area. An NSF Panel on Graphics Image Processing and Workstations report released in late 1987 on "Visualization in Scientific Computing" encourages the formation of interdisciplinary teams with a mix of skills to produce visualization tools that can be shared among diverse research areas.

The NSF panel and its recommended initiative are the results of many factors. Spurring the effort is increased recognition that the volume of scientific data being produced is overwhelming the ability of researchers to comprehend it. Coupled with this backlog of uninterpreted data is the recent introduction of advanced graphics technologies that promise to better handle vast amounts of visual data as well as the recognition that even more

continued

PCs and Scientific Visualization

The evolution of computing sheds light on the role that personal computers will take in scientific research in the future. These advances portend a day when an intimate partnership will exist between desktop computers and high-capacity machines. This partnership will extend the benefits of scientific visualization to more and more researchers by allowing personal computers to serve as viewports into the data generated by supercomputers. The large and growing numbers of personal computers within organizations have given individuals necessary computing resources, but the organizations themselves often no longer can access the peak computational capacity that they require.

This situation is analogous to equipping 100 astronomers charged with studying a distant star with 100 pairs of binoculars instead of providing them with a single large-aperture telescope. Just as even the most powerful binoculars cannot gather much useful data on the star, the most powerful desktop computer is fundamentally the wrong instrument for some applications.

The Right Resource at the Right Time

To escape this dilemma, all computer users must be provided access to whatever level of resource they need on a demand basis, with the personal computer serving as the access point. The ability to bring this model to reality hinges on the evolution of a human-to-machine interface that is adequate to support transparent escalation of computing capability. Until it arrives,

users are stuck with either big computers that have poor human interfaces or user-friendly personal computers that lack the capacity to solve really big problems.

A harbinger of what is to come for personal computers with future technology is today's multimedia workstation, which has the ability to interface to more extensive sources of data and information than can be generated locally or outside the scope of traditional alphanumeric or simple graphics displays. The impact of multimedia workstations is now seen particularly in training areas where it is possible to interact with the pictures accessed from compact disks or VCRs and displayed on the screens of personal computers. It is also seen in the image management systems that are able to store, manipulate, and interact with image data.

To make visualization more accessible, the capability of both the server computer that generates the pictures and the desktop client computer that displays them must be extended. Also, today's networking technology must evolve to complementary networks that are better suited to dealing with images and pictures.

The ability to interact with pictures across heterogeneous machines is necessary not only in the network, but more importantly in the hierarchy of the computing environment. It will extend into the server and potentially into other special-purpose machines, be they larger supercomputers or special-purpose architectures that provide other particular services in the environment.

massive amounts of data will be generated as new supercomputers emerge.

The problems of examining or assimilating the vast and growing quantities of numerical data result from increasing use of computer-based data acquisition techniques in fields like medicine. Medical diagnostic imaging, for example, generates massive amounts of data. Until recently this data was captured and used in photographic form, but it is becoming increasingly common to acquire it in digital form and to process it for review on visual display terminals.

Supercomputers are producing vast amounts of data for researchers in natural sciences like geology and astronomy and in physical sciences like chemistry and physics. As each new generation of supercomputer provides the capacity to handle larger and larger problems at far greater speeds, and as powerful "mini-supercomputers" act as computing resources to increasing numbers of researchers, more and more experimental data will be produced in each of the scientific disciplines. And orbiting satellites continue to send streams of data from space to earth, vastly increasing the amount of geophysical and astrophysical data available to researchers and analysts. But facilities for its examination

and use are being tasked to the limit by the vast data sets.

As the volumes of available data expand, researchers are increasingly hampered in fully understanding it. For example, much of the data being acquired from satellites orbiting earth is merely stored on tapes and sent to government warehouses because facilities for interpreting and understanding the data are simply not available. To prevent further waste of acquired data, it has become essential that researchers and scientists find more efficient ways to process it.

Today's Visual Applications

Ideally, scientists want to be able to compute phenomena over a time span, create a series of images that illustrate the interrelationships of various parameters at specific time periods, and analyze these images at a workstation. Although this ideal has been achieved only at certain select locations, many scientists and researchers have put visualization techniques to use in their work.

Of all applications, molecular modeling makes the best and fullest use of the interactive three-dimensional technology available today. For years, research scientists have been drawing diagrams and building molecular models to gain

insight into the way that molecules' structure influences their properties. But Styrofoam and wire only vaguely represented the real thing. The space that molecules occupy is not solid but consists of clouds of electrons moving at the speed of light. And molecules are not static; as the energy level of a molecule varies with time, its geometry changes.

Scientific visualization techniques have enabled researchers to analyze the forces generated by electron clouds and view animations of dynamic molecular sequences. The knowledge gained has been used to develop laundry soaps and shampoos; lighter, stronger materials for aircraft; and effective pharmaceuticals.

When used in designing drugs to combat specific diseases, visualization makes the process more rational than previous experimental methods. It allows researchers to analyze a compound's electronic charges and the three-dimensional shape of its molecular structure before the drug is fabricated in the laboratory to determine if it will be effective against a disease. Researchers can display the disease on a host molecule and pinpoint the active site, where the disease-causing agent attaches to healthy molecules. Having determined the shape

continued

CATCH IT FRESH

The Newest Thinking in Computer Graphics

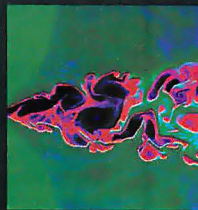

Attend SIGGRAPH '89 in Boston to catch the most inventive ideas in computer graphics. Join other forward-thinking computer graphics enthusiasts who are looking for original solutions in areas as diverse as automobile design, medical imaging, scientific visualization, and corporate presentations. Discover techniques that can keep you out of hot water.

Come to the 16th Annual Conference on Computer Graphics and Interactive Techniques in Boston, 31 July - 4 August 1989.



"Lobster" Kim, Getto, Resch/Rensselaer Polytechnic Institute
"Ozone Bubbles" Audrey Fleisher/Images II*, CGL Inc.©
"Radio Jet Disruptions by Shocks in Ambient Medium"
Norman, Burns, Sulkanen, Cox/NCSA, University of Illinois©
"Rex Goes on Vacation" Martin Maguss/San Francisco, CA©

For exhibit information contact Robert T. Kenworthy Inc., 212-752-0911.

Sponsored by the Association for Computing Machinery's Special Interest Group on Computer Graphics in cooperation with the IEEE Technical Committee on Computer Graphics.

Please send a copy of SIGGRAPH '89 registration materials to:

name _____
company _____
address _____
city, state, country _____
zip code _____
telephone _____

ACM SIGGRAPH '89
Conference Management
111 East Wacker Drive, Suite 600
Chicago, IL 60601
312-644-6610

Members of ACM SIGGRAPH will automatically receive these materials in the mail and need NOT return this coupon.

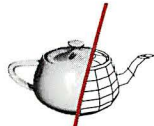

ACM SIGGRAPH 89

Subscription Problems?



We want to help!

*If you have a problem with your **BYTE** subscription, write us with the details. We'll do our best to set it right. But we **must** have the name, address, and zip of the subscription (new and old address, if it's a change of address). If the problem involves a payment, be sure to include copies of the credit card statement, or front and back of cancelled checks. Include a "business hours" phone number if possible.*

BYTE

Subscriber Service
P.O. Box 555
Hightstown, NJ 08520



and energy charge of the active site, they then display prospective drugs in the active site and can actually measure the fit and energy charge of each combination. Only drugs that actively combat the disease are then compounded in the laboratory and clinically tried.

Materials research deals with polymers that are made up of molecules consisting of thousands of repetitions of one relatively simple structure. The characteristics of the molecules determine the properties of the material. Modeling polymers using computer graphics enables researchers to investigate proposed new materials without the expense and time of synthesizing them in the lab.

Enzymes are the active ingredients in laundry soap and shampoo. To rid garments of the stains caused when proteins bind to fabric molecules, detergents provide an alternative bonding compound. This bonding compound is more attractive to the protein than fabric, causing the protein to release the fabric, bind to the detergent molecule, and be rinsed away. The structure of the molecule and the way that molecules fit together in the protein chain determine how they interact with other molecules. By displaying representations of the enzymes and the molecules to be modified, researchers can see how they interact and decide which parts to modify to produce the desired result.

Photos 1 through 5 illustrate some of the capabilities of scientific visualization in several research areas. All photos in this article were rendered on an Alliant FX/80 at the University of Illinois National Center for Supercomputing Applications.

Planning future defense systems; battle management systems; and command, control, and communications systems for the military are areas of research that involve complex theoretical simulations. Visualization techniques allow research-

ers to prove theoretical concepts before committing to the expense and time of building a prototype that may or may not work. For example, to be effective, spy satellites must be able to cover their intended area of surveillance. By simulating in real time the area of the globe that will be covered by an orbiting satellite, it is possible to detect flaws in the plan. An algorithm may show on paper that the satellite provides the desired coverage, but real-time simulation may detect flaws by running various scenarios that cover an extended period of time. One such simulation revealed that a surveillance satellite that was intended to cover the globe's surface, in fact, at a particular period of the year, failed to cover the U.S. at all!

Because tomorrow's weapons systems and military vehicles will be run by computers, it is important to determine whether the personnel charged with controlling them will be able to react fast enough. Simulations performed with a human in the loop reacting to the stream of data provided by the computer have proved that humans can react fast enough to respond as required.

Using visualization techniques in stress analysis allows the detection of potential flaws within materials that could never be seen by a human performing a visual inspection. By performing calculations on an aircraft's fuselage, for example, and displaying potential stresses, potential failure spots can be predicted for current aircraft structures. The procedure involves knowing the stresses throughout the structure, how the material performs at certain temperatures and the kind of environment in which it operates, simulating steady and dynamic stresses, and arriving at a conclusion about how long the craft can remain in service. These same techniques also can be applied to buildings, engines, or any other structures.

Photo 1:
Enzyme reaction in trisphosphate isomerase. (Research by Paul Bash of Harvard University; visualization by Stefan Fangmeier.)

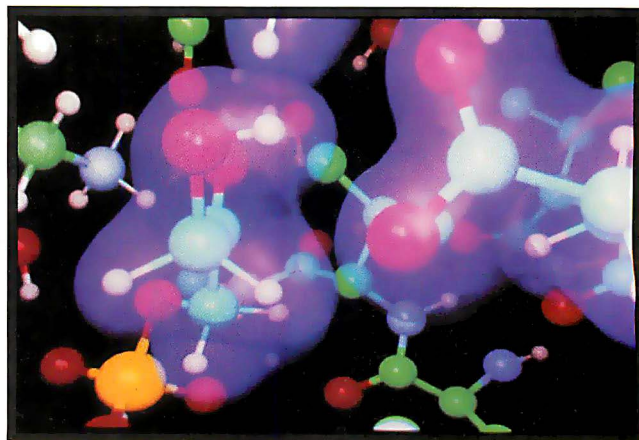

**CAD
Warehouse, Inc.**
8229 E. Washington Street
Chagrin Falls, Ohio 44022

**800
289-1650**

" PAN OVER FOR SUPER PRICES "

**CADD Workstations
featuring EVEREX STEP Series Computers**

Each system fully configured including 2 Serial Ports, 1 Parallel Port, corresponding Math CoProcessor, Enhanced "AT" 101 Keyboard, DOS 3.3, and GW-Basic. Each system thoroughly tested prior to shipment and supplied with a 1-Year "On-Site" Warranty !!!

EVEREX STEP	CACHE	40 MB MFM	80 MB MFM	160 MB ESDI	300 MB ESDI
386/25 w/4MB	64KB	\$7328	\$7570	\$8458	\$9490
386/25 w/2MB	128KB	5992	6273	7094	8127
386/20 w/4MB	64KB	6079	6318	7247	8273
386/20 w/2MB	128KB	4999	5150	5961	6972
386/16 w/2MB	128KB	4290	4532	5399	6411
286/20 w/2MB	—	3487	3726	4686	5615
286/16 w/2MB	—	3121	3359	4287	5218
286/12 w/1MB	—	2452	2687	—	—

Monitors & Card Combo's

Graphics Card with:	Mitsubishi 19" HL6905	NEC XL Multisync	Hitachi 19" CM2085	Nanao 16" 9070S	Hitachi 15" HM Series
Artist XJ10	\$4471	\$4332	\$4061	\$3000	\$3320
Artist XJ10 w/VGA	4939	4821	4524	3463	3782
Artist 12/256	5818	—	5393	—	4651
Verticom HX-16	4144	4030	3737	2676	2996
w/VGA-16	4481	4366	4072	3010	3330
Metheus 1104	3449	3339	3050	1989	2308
Metheus 1128	4160	4047	3754	2693	3012
VMI-1024/256	5269	5149	4850	3789	4108
VMI-Cobra/16	4679	4563	4267	3206	3525
Photon 1000 +	3468	3358	3069	2008	2327
Photon 2048-50	4519	4403	4108	3047	3366
#9 SGT Plus	3969	3857	3565	2504	2823
Monitor Only	2470	2350	2075	1036	1345

Digitizers

Calcomp	
12 x 12 4-Button	\$ 345
12 x 12 16-Button	345
12 x 18 4-Button	732
36 x 48 16-Button	3850
Summagraphics	
Sketch + 12 x 12	\$ 345
12 x 18	658
36 x 48 16-Button	3889
Kurta	
12 x 12 4-Button	\$ 389
12 x 17 4-Button	633
Cordless Puck Add	33
36 x 48 16-Button	3035
Hitachi	
Puma 12x12	
4 or 12 Button	\$ 399
Tiger 12 x 12 12-Button	599
36 x 48 16-Button	3872
GTCO	
11 x 11 DPC 4-Button	\$ 552
24 x 36 DPC 4-Button	2173
36 x 48 DPC 4-Button	2669

The above is a partial listing of our product line. Please inquire if you're interested in a product not listed. Prices subject to change without notice.

- * Shipping limited to Continental U.S.A.
- Quoted prices reflect a 2% cash discount.
- C.O.D., VISA, and Mastercard accepted.
- Rated companies call for terms.
- All manufacturers' warranties apply.

***** CADD BUSTER *****

EVEREX STEP 386/25 with 2MB SIMM, 387-25 Math Coprocessor, 1.2MB Floppy, 80 MB Hard Drive, 2 Serial, 1 Parallel Port, Keyboard, DOS 3.3 and GW-Basic with your choice of either Graphics Card:

Artist XJ10 - Dual
Verticom HX16 - VGA(8)
attached to a Hitachi 19" Multiscan Color Monitor with your choice of digitizer:

Calcomp 12 x 12 4-Button/Stylus
Calcomp 12 x 12 16-Button
SummaSketch Plus

and a:
Calcomp 1023 Artisan A-D 8 Pen Plotter

*** Fully configured and ready to run ***
\$ 14,350.00 -- DELIVERED *

Plotters

Calcomp	
1023 Artisan	\$3725
1043 - GT	5450
Houston Instruments	
DMP - 61	\$3545
DMP - 62	4445
Multi Pen Option	565
Ioline	
3500 A-D 1 Pen	\$2430
3700 MP	3499
4000 MP	4422
Roll Feed Option	148
Hewlett Packard	
ALL Models	CALL

Gluing the Techniques Together

What is evolving now is the glue to tie all these technologies and techniques together in a way that makes them available to individual researchers and scientists. Traditionally, large-scale simulations have been performed using long runs in batch mode on a time-shared supercomputer, and the usual pathway from supercomputer to graphics display or plotter peripheral was through a mainframe or minicomputer.

Because the very large solution data set resides on the supercomputer where it was generated and much of the work needed to render a visual image from the data set is highly compute-intensive, in some cases the supercomputer is also required to perform a large part of the graphical processing necessary to produce an image. But time on a supercomputer is expensive, and much of the graphical processing necessary is a highly repetitive, time-consuming process. Therefore, some installations are taking data generated by the supercomputer and using dedicated peripheral processing equipment (e.g., geometry engines, graphics accelerators, and image computers) to generate the images in a more cost-effective manner. These dedicated graphics processors are integrated with or attached to workstations to allow researchers to interact with the images.

Supercomputers can be connected via LANs to high-performance workstations with integrated graphics capability. This approach, however, because of the workstation's limited computing power and data storage capacity, and the relatively low data transfer speed provided by the network, requires that the supercomputer perform at least some of the post-processing necessary to reduce the volume of data sent to the workstation. And researchers are still denied the ability to interact with the process in real time, as the LAN can act as a bottleneck to high-bandwidth communication, hampering the workstation's ability to generate displays in a rapid sequence.

Visual supercomputers contain all the hardware elements required for scientific visualization in one box. They tightly integrate high-performance graphical subsystems into the computer's memory, eliminating the LAN bottleneck. These systems provide simultaneous computations and graphics, allowing researchers to view the results of their work while they make changes in computations.

Special image-passing networks currently under development will allow image data to pass between server (the

continued

Computers For The Blind

Talking computers give blind and visually impaired people access to electronic information. The question is how and how much?

The answers can be found in "The Second Beginner's Guide to Personal Computers for the Blind and Visually Impaired" published by the National Braille Press. This comprehensive book contains a Buyer's Guide to talking microcomputers and large print display processors. More importantly it includes reviews, written by blind users, of software that works with speech.

This invaluable resource book offers details on training programs in computer applications for the blind, and other useful information on how to buy and use special equipment.

Send orders to:
National Braille Press Inc.
88 St. Stephen Street
Boston, MA 02115
(617) 266-6160

\$12.95 for braille or cassette, \$14.95 for print. (\$3 extra for UPS shipping)
NBP is a nonprofit braille printing and publishing house.

INTERACTING WITH THE TINY AND THE IMMENSE

supercomputer or minisupercomputer) and client (PC or workstation) systems at very fast rates. This technology will make the use of scientific visualization possible for most scientific and engineering users by eliminating the speed bottlenecks that are encountered when trying to transmit large amounts of pixel data.

Another approach uses powerful graphics workstations. Designed to provide both the computational capability for simulation and the visualization capabilities, in stand-alone mode, machines such as these are useful in problems that

don't rely on the massive data set that makes supercomputer capability essential or to provide postprocessing for graphics display. These are typically single-user workstations that allow the user to do either computations or graphics, but not both at the same time.

Whatever the means used to achieve it, the trend toward more interactive supercomputer use is growing. High-speed paths can be provided between supercomputer and workstation to permit a researcher to get into the computational

continued

Photo 2: *Cosmic string interaction. These three renderings show a cosmic string collision at a crossing angle of 135 degrees and at a velocity of 75 percent of the speed of light. (Research by Richard Matzner, Department of Physics, University of Texas at Austin; visualization by Stefan Fangmeier.)*

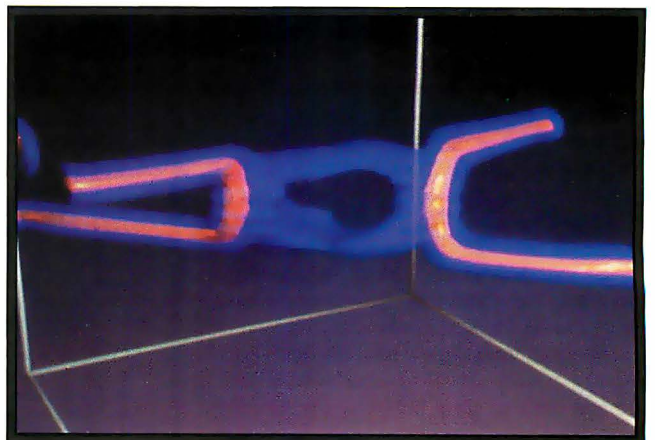
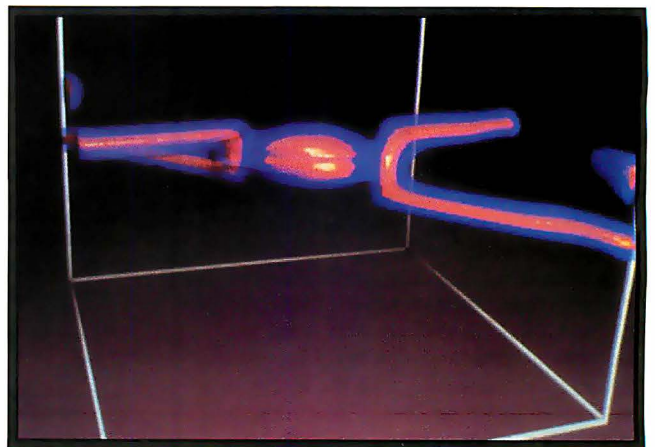
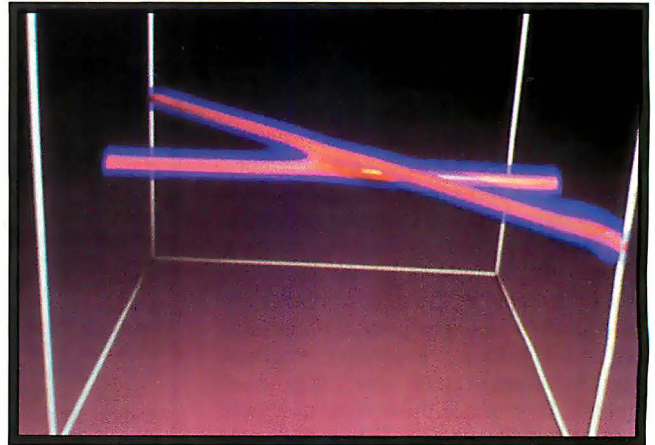

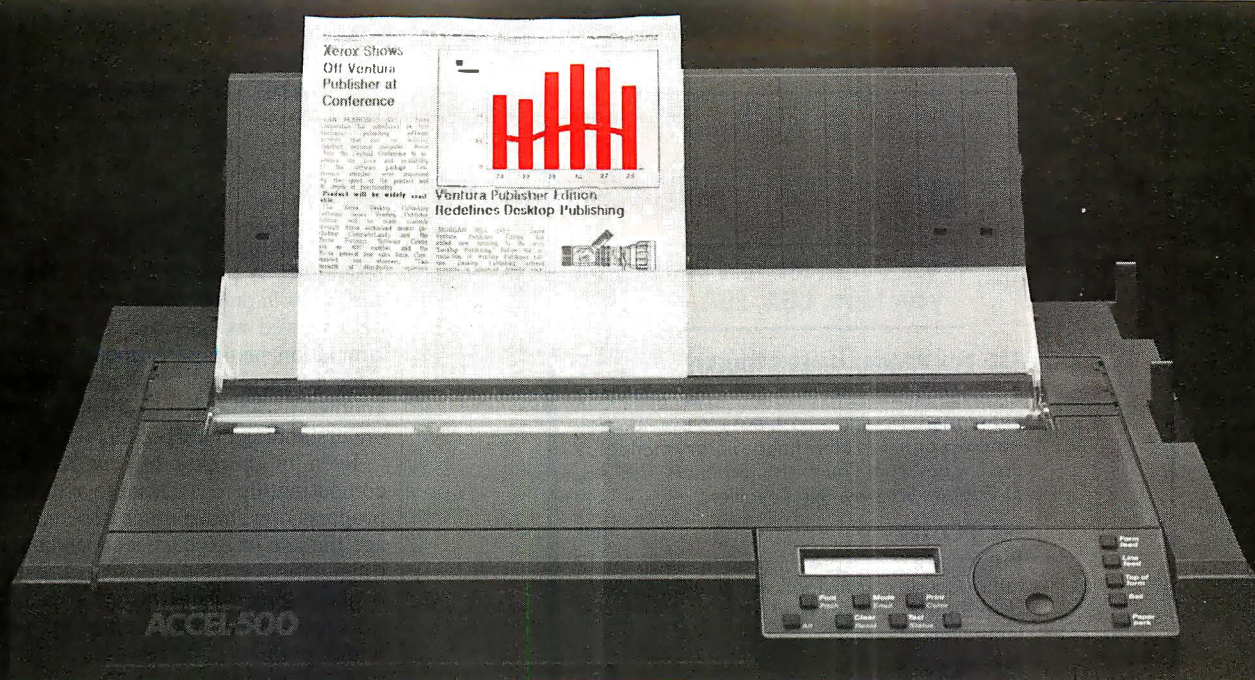

BEST VALUE PRINTER

Order today — try it FREE for 30 days.*

ACCEL-500™ users in large and small companies agree — "... It's the best value printer around! ..."

Built tough — built to last

This top performing printer offers you all you need... and more:

- Draft mode (480cps) blazing speed for reviewing draft documents.
- Memo mode (200cps) for internal documents.
- Letter quality (80cps) printing for prestige documents and correspondence.
- Graphics mode — that's right! A rainbow of vibrant colors for presentations, charts, graphs, and even your own direct mail programs.
- Plug-and-run compatibility that plugs right into your PC or Macintosh — virtually any computer or network.

Toll-free helpline

We're with you all the way. The ACCEL-500 comes with a full 2 year warranty. If you have any questions, pick up the phone and talk to our experts. In addition, we provide on-site service that puts an engineer in your office if you ever have a problem.

Three reasons to order today.

1. Order today and we will ship it to you for a 30 day FREE trial. If you're not delighted, simply ship it back and receive a full refund.
2. Order today and we will throw in a full year of on-site service — value \$215.00 — Free of charge.

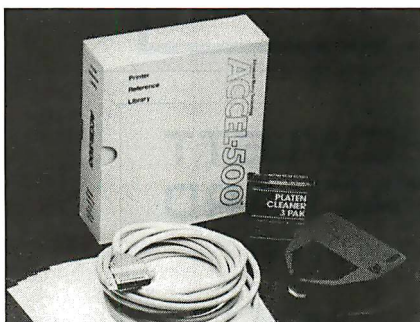

3. Order today and we will include our Quick Start Kit — value \$150.00 — for just \$25.00. You get software, cable, documentation, supplies and more.

The easy to use printer.

Just place your finger into the ACCEL-500's patented SelectDial™ wheel and turn. Different type styles, speeds, and printing features are right there. And plug-in Intelli-cards™ provide instant software upgrades.

The ACCEL-500 comes with a built-in tractor feed for continuous paper, and will accept optional sheet and envelope feeders. It also comes in a choice of colors: Executive Black and traditional Ivory.

More for your money.

The ACCEL-500 is priced at just \$1,085.00. With your order you'll receive:

- 16K internal buffer.
- Six printer emulations.
- Four fonts.
- Color and black ribbons.
- User and programming documentation.
- Internal diagnostics.

- Special word processing features.
- Graphics capability.
- Store 4 user configurations for quick and easy set-up.
- 17-inch carriage.

ORDER TODAY
Toll free
(800) 637-7878

Call us toll free. We will answer all of your questions and take your order for shipment within 24 hours.* Use your Visa or MasterCard with NO service charge, or alternatively, give us a purchase order number and we'll ship.* Express delivery and quantity discounts available, please ask for details.



Ventura
Peripherals

100 Rancho Road, Suite 27
Thousand Oaks, CA 91362.

*On approved credit and subject to availability.

ACCEL-500, SelectDial and Intelli-card are trademarks of Advanced Matrix Technology, Inc. ©1989 Ventura Peripherals. All rights reserved.

Circle 33 on Reader Service Card



GRAPHICS

Break Out of the Text Barrier with your Herc, CGA, EGA, or VGA

PCX PROGRAMMER'S TOOLKIT \$125
Over 55 routines to display, save, print PCX bitmapped graphics - Fast, easy to use - Display windows or full screen - Image library manager - use images from Paintbrush, Scanners, Clip-Art, or Capture Screens - No Royalties!

PCX TEXT \$99
Display text in any graphics mode - Includes 12 fonts - Create custom fonts with dual font editor - User input routines - Font scaling - Additional fonts available.

PCX F/X \$99
Add Special Effects ('FX')! Fade, wipe, push, roll, slide, split, crush, spiral, explode your graphics! Palette manipulation - Animation - Sound Effects

All packages support 12 compilers for BAS, PASCAL, C, FOR, ASM and Clipper.
Source available.

G · E · N · U · S

M I C R O P R O G R A M M I N G

1315 Meadow Lake • Houston, Texas 77077 • (713) 870-0737

800•227•0918

INTERACTING WITH THE TINY AND THE IMMENSE

loop. Working on-line to the computer, a researcher is provided with high-bandwidth visual output that enables results to be reviewed as they are obtained. The simulation being performed can be altered interactively to explore the effect of another parameter, providing a greater understanding of the problem.

Even in the case of long-run batch computing, there is a need to monitor the progress of a run in order to better manage the use of expensive supercomputer time. This is typically done by providing a quick-look visualization capability. This approach also requires a high-bandwidth path to transfer data from the supercomputer to the graphics display.

Another challenge is to provide the kind of graphics software that will give potential users access to the features of visualization hardware. This software must be able to utilize the most powerful features of the hardware, it must be flexible enough to accommodate changes in hardware technology, and it must provide human-to-machine interfaces that are friendly and attractive to users in a variety of scientific disciplines.

Much of the visualization software currently in use was developed for particular hardware configurations or to support research in a specific scientific discipline. Some visualization centers use adaptations of commercially available systems that were created to perform image synthesis and animation applications, to attain visualization capability.

Computer graphics and digital image processing have traditionally been two distinct technological activities aimed toward different types of applications. Many scientific disciplines benefit most when techniques and technologies from both graphics and imaging are merged. Visualization techniques combine the two activities. Visual comparison of theory with observation is an example of this utility. Experimental or observational results are frequently depicted by images that are captured by photography or other sensing technology. Theoretical results, on the other hand, are represented as imagined physical models. These models are interpreted as geometric objects that can be rendered into images using computer graphics techniques. Comparison of the images produced by the two techniques requires the application of image-processing technologies.

Completing the Picture

Cultural differences between scientific and artistic users of visualization tools, as well as technical differences between

continued

hp **HEWLETT
PACKARD**

Authorized Dealer

Top Quality HP!

NOW In Stock!

Hewlett-Packard Supplies

CAD Plotters from Hewlett-Packard

- Fast Service
- Fast Delivery
- Low Prices
- Corporate Accounts Welcomed



Impact Computer Systems, Inc.
Glen Wild Rd. Glen Wild, NY 12738

Call Now 1-800-431-3400

In N.Y. State 914-434-3338

Aw...What the Heck!

EXTREMELY POWERFUL

DesignCAD 3-D version 2.0 is as powerful as most CAD systems costing \$5000 - \$10,000! Features like: Complex Extrusions-linear, scalar, and circular, Blending of Surfaces, Shading, Cross Sectioning, Complex Sweeps and Translations, and Boolean operations make DesignCAD 3-D one of the most powerful 3-D CAD systems available... at any price! Engineers, Architects and Consultants constantly tell us that they use CAD systems costing thousands of dollars which are not as powerful as DesignCAD 3-D.

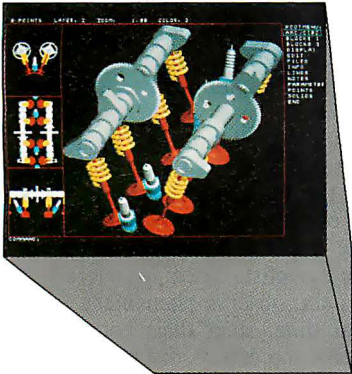

VERY EASY TO USE

Just because DesignCAD 3-D is powerful doesn't mean it is difficult to use. Single keystroke commands and side-bar menus which give short directions on how to proceed make DesignCAD 3-D a snap to use! While not required, DesignCAD 3-D supports all popular digitizers and mice.

Many of the older, more cumbersome CAD systems require weeks of training before a user can be productive. DesignCAD 3-D users find they can be producing useful drawings in a matter of minutes! In a recent CAD contest only one contestant was able to match our drawing time. The package sold for \$3000.00. The other CAD packages took up to twice as long to perform the same drawing and cost up to \$5000.00!

Still don't believe us? The goblet pictured below required only 16 keystrokes and 3 commands to create! The top, front, side, and isometric views were created simultaneously... in less than one minute!

VERY LOW PRICED

The first question asked by many people is, "Why is DesignCAD 3-D priced so low?" The answer? After developing DesignCAD 3-D version 2.0, we were unable to decide how the product should be priced. We consulted experts. We used the finest spreadsheets on the market. We took employee polls. Finally, in the great American Tradition, we said, "Aw... What the Heck! Let's see the other guys beat this price!" DesignCAD 3-D version 2.0 sells for \$399.



DesignCAD 3-D only \$399!

WHY BUY THIS ONE?

There is a very important reason to buy DesignCAD 3-D. PERFORMANCE. No other CAD system can match our price/performance ratio. Many people make the serious mistake of thinking that it is necessary to spend thousands of dollars to obtain "a good 3-D CAD system." This is not true! We talk to people everyday that are sadly disappointed with their "expensive" CAD systems. Don't be one of them! Call us and we will send you a complete set of literature and a free slide show demo disk. Once you compare DesignCAD 3-D version 2.0 with other CAD systems we know you will choose DesignCAD 3-D.

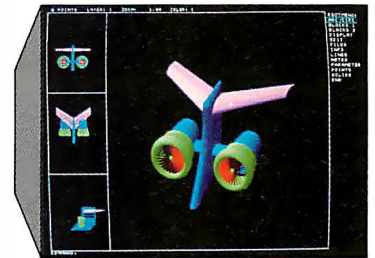
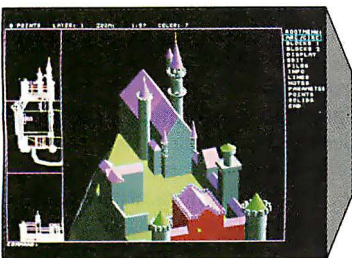

DON'T TAKE OUR WORD FOR IT

Here is what other people have to say about DesignCAD 3-D:

"After you've worked with DesignCAD, the single keystroke commands are simple to remember and it becomes easy to "flick one key" to execute a command. An extremely ergonomically designed program."

HENRY LEVET, Levett & Daigle Architects - New Orleans, LA
Designed a 65,000 sq. ft. nursing home using DesignCAD

"Recently I worked with a firm that builds decks. They purchased your product on my recommendation. I sat down with them and in two hours they were very proficient in DesignCAD. Now they are more effective; and we can communicate... it's wonderful to be able to do a block repeat 42 times and there are 42 2x4's to make the deck!"

J. TURNER, Architect, TAO Ltd. - The Woodlands, Texas

"Allows scientists and engineers to expend minimum time learning and using CAD software so that their time can be expended on the project at hand. It also allows scientists and engineers to quickly present to management all views of a subject. (3-D)."

DR. STEVENS, NASA Space Scientist/Engineer



HOW DO I GET ONE?

DesignCAD 3-D version 2.0 is available from most retail computer stores, or you may order directly from us. DesignCAD 3-D is available in a number of foreign languages from distributors throughout the world. All you need to run DesignCAD 3-D is an IBM PC Compatible and 640K RAM. DesignCAD 3-D supports most graphics cards, printers, plotters and digitizers. Free information and a demo diskette are available by contacting us at:

American
Small Business Computers, Inc.

327 South Mill Street
Pryor, OK 74361
918/825-4844
FAX: 01-918-825-6359
TELEX: 9102400302

end-user scientists and computer scientist computing center managers must be overcome to provide the scientific community with access to visualization technology. The teams being formed to implement visualization technology, such as the University of Illinois National Center for Supercomputing Applications group, are designed to accomplish this by bringing together scientists and graphics experts. A common understanding of the diverse problems faced on either side will provide the knowledge and sensitivity needed to overcome diffi-

culties and will result in tools that can be effectively used by researchers in many disciplines.

Ideally, scientists want to be able to compute data, generate sequences of images, and analyze these images at a workstation. However, workstations that are capable of providing high-performance, high-resolution graphics often are priced outside the researchers' budgets. But many scientific problems can be analyzed interactively without high-quality three-dimensional graphics. Scientists don't always require dazzling pre-

sentations to benefit from visualization techniques. They need very high-quality visualization to present or publish known information, lesser quality to share information with colleagues, and a third type of visualization to study phenomena by themselves or with collaborators.

While presentation images require the use of powerful equipment and the assistance of visualization experts, when graphics are used to share scientific discoveries among peers, the primary requirement is for clear visual representation of information. This can be provided by equipment as simple and inexpensive as a video recorder in a graphics workstation.

Personal graphics for scientific analysis is the most important of the three types of visualization because it results in the greatest productivity. This is where scientists need to interact with their data, observe phenomena in close to real time, steer their computations, and have the effects displayed immediately on the screen in graphical format. The emphasis is on data representation and interactivity, not on quality. It is at this level that next-generation personal computers will take a more active part in the scientific process.

Already providing high-resolution color graphics capabilities, next-generation personal computers will also offer higher levels of computational performance, better communications capabilities to speed data transfer, and a better-designed human interface to encourage widespread use by researchers. The price levels at which these tools will be made available will enable even the most cost-conscious project director to put them on every researcher's desktop. ■

ACKNOWLEDGMENTS

I would like to thank the following people for their contributions to this article: chemistry applications, Dr. Paul Weiner, chemist, Alliant Computer Systems Corp.; techniques, history, and future developments, Stefan Fangmeier, chief scientific visualizer, University of Illinois National Center for Supercomputing Applications; structural analysis, Neville Rieger, president, Stress Technology, Inc., Rochester, New York; simulation applications, Scott Adcock, manager of computer graphics, Colsa Corp., Huntsville, Alabama.

Craig Mundie is vice president of R&D for Alliant Computer Systems Corp., Littleton, Massachusetts, a maker of supercomputer visualization systems. He can be reached on BIX c/o "editors."

Photo 3:
Tornadic storm. This is the moment at which a storm becomes a tornado. (Research by Bob Wilhelmson, research scientist at NASA; visualization by Stefan Fangmeier.)



Photo 4:
Formation of Venus plasma clouds and streamers. (Solar wind research by Robert Wolf and Michael Norman, astronomers at the University of Illinois; visualization by Stefan Fangmeier and Matthew Arrot.)

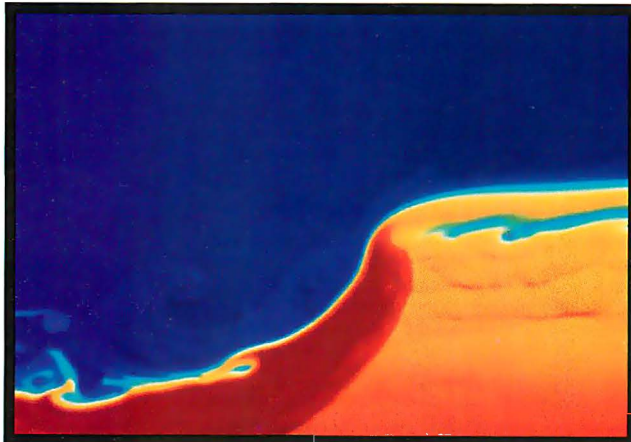
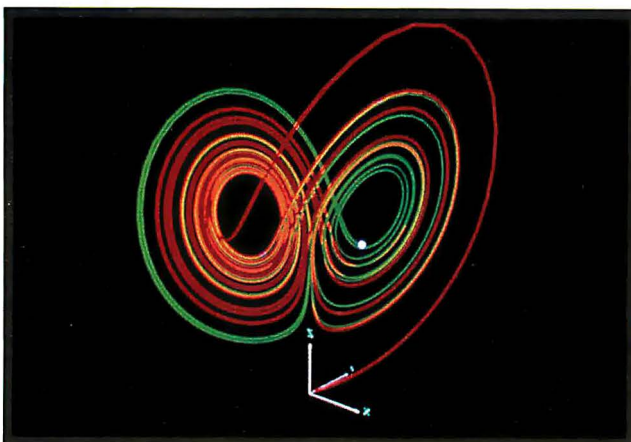

Photo 5:
A visualization of the first system of equations in which the "chaos" phenomenon was discovered. (Research: David Hobill, Dan Simkins, and Michael Welge, University of Illinois; visualization: Jeffery Yost.)



GFX Fonts & Menus...

See what you've been missing

Your C graphics library may be OK for drawing lines, circles, and pie slices, but what about features for text output and building an easy-to-use graphics interface?

Is text output lightning fast? Can you choose from a wide variety of sizes and typefaces? Can you center and right justify your text; or xor it onto the screen and move it about without destroying the background?

And how about an intuitive graphics user interface? How's your mouse control? Are you going to blow a month writing an interface with pull-down menus and dialog boxes?

Whether you're using a stand-alone graphics library or C compiler, we know you're missing most or all of these features and the GFX Fonts & Menus Library supplies them.

Fast Text Output:
On an EGA card, we're more than twice as fast as our nearest competitor; and we're just as fast on CGA, VGA and Hercules™ cards. Our code is fast and tight . . . the library is under 25K.

Graphics User Interface:
We've designed a full-featured graphics interface that your users will love; with pull-down menus, dialog, scroll, and forms boxes.

Easy To Code:
Data structures describe all menus and boxes. Call a function to display a structure and we'll handle all user interaction with the menu or box and return the final result.

Huge Font Selection:
We provide over a megabyte of fonts and icons that you can distribute with your programs. Many typefaces, sizes and styles.

Font & Icon Editor:
You can use our font editor to add, delete or change icons or characters; create new fonts or icon files; and scale your fonts.

C Source Code & No Royalties:
The package comes with source code ready to compile for your C compiler: Microsoft, Borland, Lattice or Metaware.

Special Offer—Save Up To \$125:
Thru May 15, you can get GFX Fonts & Menus and the GFX Graphics Library at a big savings.
The GFX Graphics Library, which retails for \$125, is small, fast and comes with source code. In addition to lines, circles and pie slices, it's got scalable viewports, fast area fills and a program to translate to and from PCX files.

GFX Fonts & Menus Library	
Retail	SALE
\$150	\$115
GFX Graphics + Fonts & Menus	
Retail	SALE
\$275	\$150

ORDER NOW
or call for more information
1-816-353-8808
Visa/MasterCard/C.O.D.
Free Bulletin Board Demo
1-816-353-6038

30 Day Money Back Guarantee

Circle 73 on Reader Service Card

SOURCE
C Source, Inc.
12801 Frost Rd.
Kansas City, MO 64138
(816) 353-8808
FAX: (816) 353-6059

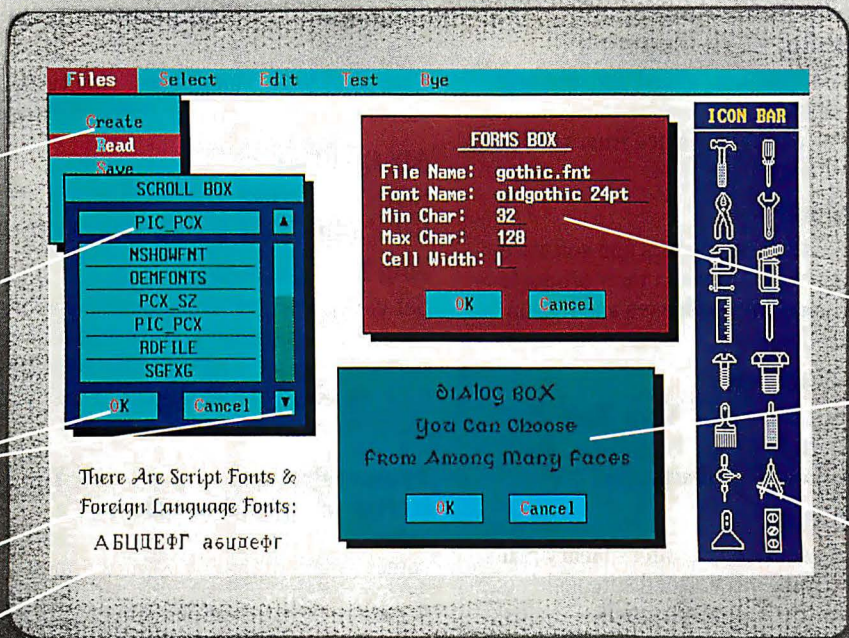

Menu items can be selected with mouse or keyboard.

Use the scroll box to choose an item from a long list.

Scroll the list and select an entry with mouse or keyboard.

Over a megabyte of fonts and icons.

ACTUAL PHOTO

Easy text and data entry.

Messages and warnings are a snap.

Use icons to choose an action.

Seven great reasons to join BIX. The on-line service for computing professionals

*Over 200 microcomputer-related conferences:

Your BIX subscription connects you with experts on Macintosh, IBM PC and compatibles, the Apple II family, Amiga, Atari, and UNIX machines. Join our OS/2 conference and learn about the new presentation manager.

*Microbytes daily – the award winning on-line news service:

Get up-to-the-minute industry news and new product information covering the IBM, IBM-compatible, Apple Macintosh and workstation markets.

*The full text of BYTE Magazine:

Each month BIX publishes the complete text of BYTE available on-line before the magazine is printed. Plus each issue since August 1988 is available for searching.

*Vendor support:

Hundreds of hardware vendors and software publishers use BIX to support their products. Get answers about new releases and tips on how to use products.

*Software libraries:

Including libraries for PCs, Macs, Apple II, Amiga and Atari. Join the "FromByte" area to get listings from BYTE articles.

*Electronic mail:

BIX is the only service that offers binary mail attachments. Now you can send spreadsheets, pictures, word processing documents, or desktop publishing files. You can even use BIX mail to distribute software updates.

*New menu interface:

The new BIX menus provide a convenient map of the system and include powerful options like the BIX Index where you can search all the BIX conferences. The Quick Download option will collect all of your mail messages and new conference messages and send them to you saving valuable on-line time.

What BIX costs: How you pay

One time registration fee: \$39

Hourly Charges:

	Off-Peak	Peak
(Your time of access)	7PM-6AM \$11	6AM-7PM \$20

Charge to Visa, Mastercard, American Express or ask about our corporate billing.

BIX Help Line

800/227-2983

603/924-7681 in New Hampshire

Join BIX right now:

Set your computer's telecommunications program for full duplex, 8-bit characters, no parity, 1 stop bit. Call 800/336-0149 and ask for your local Tymnet number. Dial Tymnet and respond as follows:

Tymnet Prompt:	You Enter
[x] [xx] or terminal identifier	a
login:	bix
name:	new

After you register on-line you get the BIX Main Menu and you can begin to explore the exciting world of BIX.

BIX

One Phoenix Mill Lane, Peterborough, NH 03458 1-800-227-2983 ♦ In NH (603) 924-7681

Display this month's
BIX activities:

A P R

MONDAY, 4/3, 9 PM EST. "Space Art—an engineering tool"

Pat Rawlings, a leading artist in the fields of science-fiction and space, will be the guest at a special CBIX session sponsored by three conferences: s.f., photo, and ibm.at. Rawlings is the director of Eagle Visuals (a subsidiary of Eagle Aerospace Corp.), and his illustrations have appeared in major science and sci-fi publications. In March, he addressed the AIAA on the role of art in space. (join cbix)

TUESDAY, 4/4, 9 PM EST. LANS and networking

Designed for developers and users, this IBM PC "First Tuesday" conference will include discussions on applications—existing and planned—as well as problem-solving. (join ibm.pc/cbix)

TUESDAY, 4/11, 9 PM EST. Want to add more horsepower to your AT clone?

The place to go for information this month is this IBM AT conference, where you'll take part in a discussion on "Upgrading the AT clone to 386 vs high-speed 286." (join ibm.at/cbix)

WEDNESDAY, 4/12, 9–11 PM EST. "Lattice" answer your questions.

If you use Lattice products, here's a chance to ask questions of the Lattice staff. (join lattice/cbix)

TUESDAY, 4/25, 9 PM EST. How to avoid TSR traps and more.

Terminate and Stay Resident programs remain full of traps for the unwary programmer, but Barry Nance can rescue you. The BIX Technology Group Moderator will share with you his experiences with TSRs—and his sample code in Turbo-C and assembler. (join cbix)

THURSDAY, 4/27, 8 PM EST. And you thought you've had telephone trouble?

Find out what it's like trying to telecommute from really remote sites. Join BIX Telecomm Group Moderator Brock Meeks as he recounts his adventures last month in Afghanistan, where he was a correspondent for a San Francisco newspaper (toting his faithful Model 200 and Toshiba 1000). (join cbix)

All-Month Conferences

BYTE's *In-Depth* section this month is on CASE. BIX will augment it with a month-long examination of CASE, featuring Ron Schroeder, Associate Professor of Applied Computer Science, at the Southern College of Technology, in Marietta, Georgia. The discussions will be in our software-engineering conference. (join soft.eng.)

BIX's Contact conference will examine the blurring distinctions between science-fact and science-fiction in the age of superconductors, biologically engineered life forms and humans living in space for extended periods. Whether you're in the "fact" or "fiction" camp, you'll want to share information and debate the issues, in

preparation for the 6th annual CONTACT symposium in Phoenix, April 27–30. (join contact)

Geoff Gilpin, author of the JANUS/Ada Extended Tutorial, will conduct an online Ada tutorial this month. (join janus.ada)

Only BIX subscribers may attend BIX conferences. Our ad on the adjoining page will tell you how you can subscribe.

BIX

One Phoenix Mill Lane ♦ Peterborough, NH 03458
1-800-227-2983 ♦ In NH (603) 924-7681

THE TRON PROJECT

An open architecture, a family of VLSI chips, and system software designed to revolutionize the way we use computers

Ken Sakamura and Richard Sprague



Computers are now used in every product imaginable, from household appliances to automobiles to calculators, yet there are no standards for letting those computers communicate with each other. A standardization effort called TRON (The Real-Time Operating System Nucleus) aims to establish a set of common data-interchange standards that will make it easy for all computers to communicate in real time.

The central philosophy of the TRON project is that computers will become more distributed and their uses more varied, and that the overall power of computers will increase if they can work together. There are few standards for communications between PCs and mainframes and among multiple character sets.

Another issue that has been largely ignored involves standards for real-time, as well as multiprocessing, communications between devices. The user feels these problems, too: Incompatible interfaces between systems make it difficult to imagine different computers as part of a single world network.

TRON is an ambitious, broad-based response to these issues and has already received the participation of many of the major Japanese computer companies and leading semiconductor makers, as well as a number of U.S. and European software and hardware companies. The name TRON applies to the development of the whole concept, not a specific product. TRON encompasses the development of an open architecture, a family of VLSI chips, and system software.

TRON's designers consider an open-architecture philosophy essential and believe it is the most important factor in its receiving wide adoption by manufacturers. For this reason, all TRON specifications are available for adoption by anyone, free of charge. TRON standardization is coordinated by a nonprofit organization, the TRON Association, in cooperation with the University of Tokyo.

The three most important aspects of the TRON project are the concept of highly functional distributed systems, operating system software on the TRON PC, and the TRON CPU.

Highly Functional Distributed Systems

Until the popularization of LANs and other means for easy exchange of data among desktop computers, PCs were largely kept independent of one another. A primitive means of PC-to-PC communication existed—writing data to a floppy disk, and hand-carrying that disk to another computer. But in general, documents developed on one machine were not typically used by other machines.

Exactly the same situation now exists for computers used in embedded systems, such as the microprocessors that are now standard components of everything from microwave ovens to VCRs. Primitive means of data-sharing sometimes exist, but only on a case-by-case basis using specialized products. For example, some advanced calculators offer add-on interfaces that let you exchange ASCII data with the IBM PC, and crude devices exist for communication with VCRs. But there is nothing comparable to the easy connectivity among desktop computers now available with LANs.

TRON's essential goal is to bring the concept of networking to all computers, including those used internally in consumer products. IBM's Systems Application Architecture (SAA) has a similar purpose, but its scope is limited to traditional computer systems. The TRON operating system, however, defines multiple application-specific architectures covering every domain in which computers are used. These areas are

- ITRON, for embedded industrial systems;
- BTRON, for business-oriented workstations;
- CTRON (central TRON), for large file servers in networking environments;
- MTRON (macro TRON), for interconnecting "intelligent objects" and super personal computers or workstations.

Each of the TRON subfamilies is designed to be compatible with the others (see figure 1). A good analogy of how these families work together is the open system interconnection, or

continued



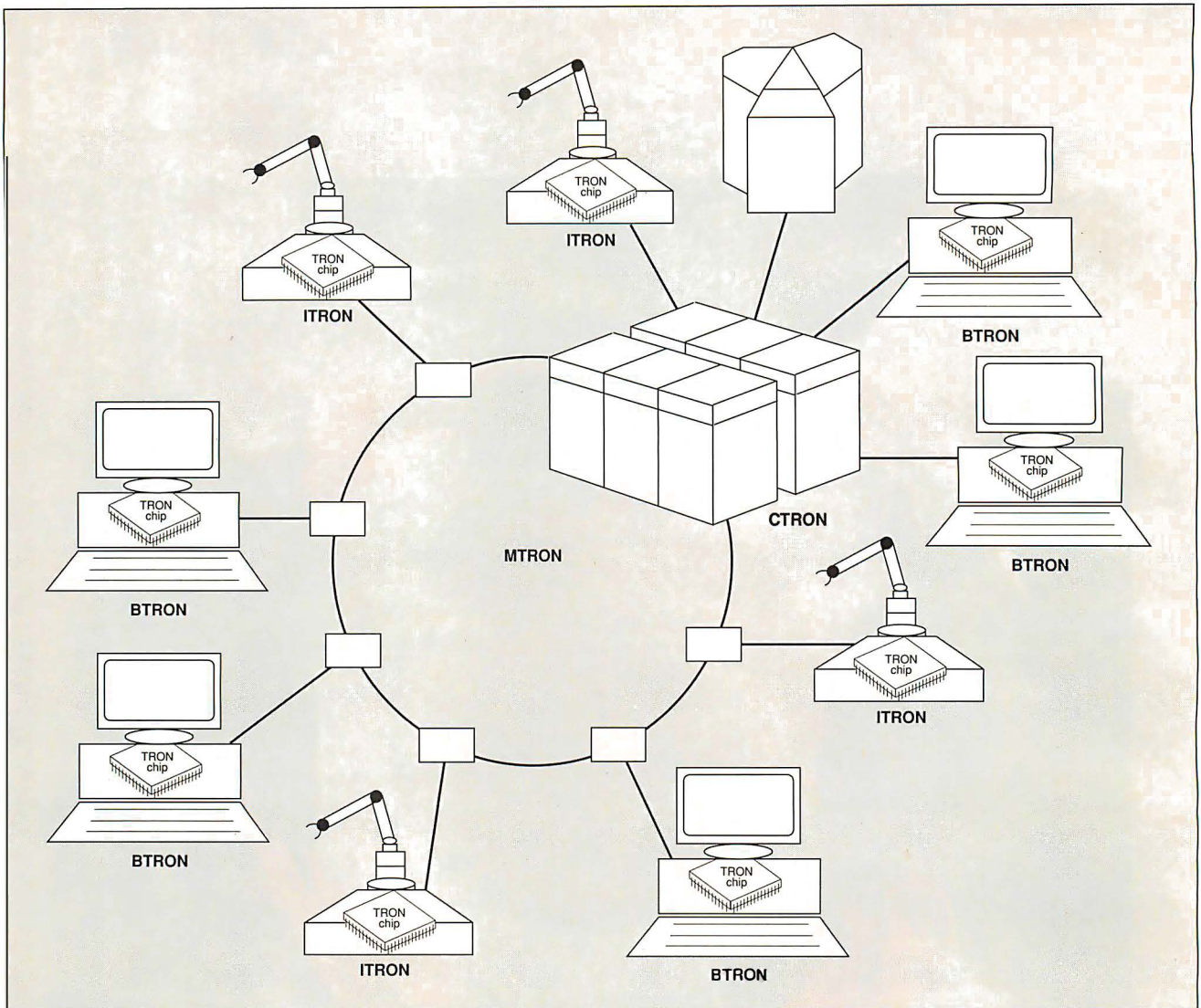

Figure 1: In the TRON world, BTRON workstations can communicate with ITRON industrial computers and share data with a mainframe through a CTRON file server. The network linking these and other "intelligent objects" together is MTRON.

OSI model, well-known in the data communications industry.

Like the OSI model, the TRON project is divided into layers: an instruction-set-processor layer, an operating-system kernel layer (which is separated into the I/B/C/MTRON architectures), the operating-system shell layer, and an application and human/machine interface layer. Also like the OSI model, work on the individual TRON layers can proceed independently of work on the others, with confidence that the resulting total TRON architecture will fit together.

The four separate operating-system kernels are designed to satisfy the broad categories of applications that will need interconnection by computers of the future. The four are used independently, but they are designed to easily exchange data.

The ITRON and CTRON Kernels

In the industrial field, microprocessors use many real-time operating systems. None of these operating systems has distinguished itself as a standard in the way Unix has become a de facto standard in the field of software development. ITRON is an attempt to create such a real-time standard.

Industrial applications require fast response time to external signals, and the ITRON specification has been designed to permit it. Using a two-level approach to standardization, ITRON tries to achieve rapid response time with a very low overhead.

On the upper level, the TRON project defines a machine-independent logical interface, which includes universal aspects of real-time systems such as intertask communication. The second level is a CPU- or architecture-dependent part, which determines the performance of real-time systems.

The ITRON specification includes a wide variety of system calls, many of which can be removed from the kernel to improve the performance of a specific application. For example, although ITRON specifies task synchronization primitives for semaphores, event flags, mailboxes, and others, an application that uses only semaphores may legally remove all the other synchronization primitives from the kernel.

CTRON is the specification for a multiuser operating system that works with machines and networks linked with ITRON and BTRON. It is designed for applications that require very large data bases and memory storage or extremely fast process-

ing. CTRON is also oriented toward high-speed, high-quality printing, graphics, and voice processing.

The MTRON Kernel

In the future, microprocessors will be found in an ever greater variety of products. Walls of TRON houses will have processors that sense temperature and pressure variations and send the information to microprocessor-controlled doors and windows.

Massive numbers of processors, called *intelligent objects*, will require real-time control by, and compatibility with, other TRON computers. The smart network that links them together is called MTRON. An underlying programmable specification language called the TRON Universal Language System (TULS) makes it possible to design a set of standard communication protocols to coordinate all these intelligent objects.

The ultimate goal of the TRON project is to build a highly functional distributed system in which billions of intelligent objects can be connected to work cooperatively.

The BTRON Kernel

The TRON family that will ultimately be most important to the PC and workstation industry is BTRON, an open-architecture specification of computers meant for use as personal workstations by businesses and homes. People will want future business- and home-oriented computers to be easy to use, so the BTRON design pays careful attention to its user interface.

Users of window-based systems, like the Macintosh and Microsoft Windows, will be familiar with many of BTRON's user-interface design techniques. Another BTRON feature that

will be especially appealing to the international market is the ability to deal with large character sets. BTRON imposes no constraints on the size of its character set.

Since BTRON machines require much more interaction with users than other TRON families, the user-interface specification is the most critical part of the design. BTRON relies heavily on bit-mapped graphics, and input can be done with either an ergonomically designed keyboard or a pointing device, a stylus that the TRON project designers consider superior to the mouse for most tasks (see photo 1).

New applications for computers based on the BTRON concept were created for users of individual computers networked with other computers and used as mediums for information exchange and presentation. BTRON defines several functions to make this condition possible.

The BTRON specification supports the processing of large numbers of different characters in as many languages as possible (if possible, all the characters used in the world). Unlike the 8-bit character-based operating systems of the past designed to handle the Roman alphabet only, the BTRON specification begins with a more generalized approach to language processing.

The BTRON specification allows both 1-byte and 2-byte codes to coexist. A 1-byte code permits the use of 2^8 (or 256) characters; a 2-byte code permits the use of 2^{16} (or 65,536) characters. This feature permits the storage efficiency of 8-bit codes for Roman-like languages, while enabling the elegant representation of large character sets for languages like Japanese. The operating system allows each language to choose its

continued

Color Graphics, we give you the tools, you give your imagination

Captured at 24 bits with ColorFreeze-24™, color separated with Modern Artist™ 2.0



Call toll free 1-800-547-3303 for complete information on our products and multimedia, animation packages or consult your nearest Apple Dealer.

We give you a complete, professional and integrated solution for your TV, print, animation and paint production requirements, at a price you can afford.

TV Producer™ Animation

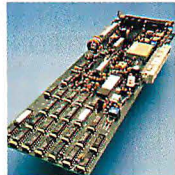

Gen-Lock Overlay Card.

Basic tool for multimedia presentations. Send your presentations to video or tape them on VCR. Overlay graphics on live video. Available with animation software.

ColorFreeze-24™ Electronic Color Photography.



Capture high quality color or black and white shots from camera or VCR, modify and save in your favorite paint program or desk-top publishing program (QuarkXpress™, PageMaker™ etc.).

Modern Artist™ 2.0



Most complete and versatile color paint program. Spectacular special effects. Includes 4 color separation for professional color printing.

PanChroma™ Printer



Finally 300 dpi color printing in a compact, reliable and affordable thermal color printer. Produce beautiful color illustrations or instant color transparencies for your presentations.

Computer Friends, Inc. 14250 NW Science Park Dr. - Portland OR 97229 - tel. (503)626-2291 - fax (503)643-5379

Want to save Time, Money,
& Headaches?



GET SUPERSOFT'S
SERVICE DIAGNOSTICS

All the software, alignment diskettes, parallel/serial wrap-around plugs, ROM POSTs and extensive, professional documentation to provide the most comprehensive testing available for IBM PCs, XTs, ATs and *all compatibles* under DOS or Stand Alone. No other diagnostics offers such in-depth testing on as many different types of equipment by isolating problems to the board and chip level.

NEW: SuperSoft's **ROM POST** performs the most advanced **Power-on-Self-Test** available for system boards that are compatible with the IBM ROM BIOS. It works even in circumstances when the Service Diagnostics diskette cannot be loaded.

NEW: 386 diagnostics for hybrids and **PS/2s!**

For over nine years, major manufacturers have been relying on SuperSoft's diagnostics software to help them and their customers repair microcomputers. End users have been relying on SuperSoft's Diagnostics II for the most thorough hardware error isolation available. Now versions of Service Diagnostics are available to save everyone (including every serious repair technician) time, money, and headaches in fixing their computers, even non-IBM equipment.

All CPUs & Numeric Co-processors	All Color Graphics & Monochrome Monitors
System Expansion & Extended Memory	Parallel & Serial Ports
Floppy, Fixed & Non-standard Disk Drives	Mono, CGA, Hercules & EGA Adapters
Standard & Non-standard Printers	All Keyboards & the 8042 Controller
System Board: DMA, Timers, Interrupt, Real-time Clock & CMOS config. RAM	

Join the ranks of XEROX, NCR, CDC, SONY, PRIME, ... who have bundled SuperSoft's diagnostics with their microcomputers at no risk because of our 30 day money back guarantee.

Service Diagnostics for PC, PC/XT, and compatibles only.....	\$169
Alignment Diskette for PC, PC/XT and compatibles (48 tpi drives).....	\$ 50
Wrap-around Plug for PC, PC/XT and compatibles (parallel and serial).....	\$ 30
Service Diagnostics for AT and compatibles only.....	\$169
Alignment Diskette for AT and compatibles (96 tpi drives).....	\$ 50
Wrap-around Plug for AT (serial).....	\$ 15
ROM POST for PC, PC/XT and compatibles only.....	\$245
ROM POST for AT and compatibles only.....	\$245
Service Diagnostics: The KIT (includes all of the above—save \$502)	\$495
Service Diagnostics for 386 or V2, V30, or Harris, etc. (please specify).....	\$195
Diagnostics II is the solution to the service problems of users of all CP/M-80, CP/M-86 and MS-DOS computers.....	\$125
ROM POST for PS/2 and compatibles only.....	\$245
Alignment Diskette for PS/2 and compatibles (3.5 inch).....	\$ 50

To order, call 800-678-3600 or 408-745-0234
FAX 408-745-0231, or write SuperSoft.

your microcomputer repair solution

SuperSoft

FIRST IN SOFTWARE TECHNOLOGY P.O. Box 611328, San Jose, CA 95161-1328 (408) 745-0234 Telex 270365

SUPERSOFT is a registered trademark of SuperSoft, Inc.; CDC of Control Data Corp.; IBM PC, AT & XT of International Business Machines Corp.; MS-DOS of MicroSoft Corp.; NEC of NEC Information Systems, Inc.; PRIME of PRIME INC.; Sony of Sony Corp.



Photo 1: The BTRON standard PC includes a flat-panel display, an ergonomic keyboard, and a stylus pointing device. Everything from the CPU instruction set to the user interface was designed as a unit.

own algorithms for direction of writing, formatting rules, and input methods.

BTRON provides a common format for the representation of graphical data. The operating system includes hypertext-like features such as an outline processor and the ability to link documents in network fashion.

The BTRON Real-Object/Virtual-Object Model

A file system is the part of an operating system that provides for the storage, representation, and management of data. Most file systems consist of static ASCII data stored in files, which are grouped into directories. In Unix and MS-DOS, for example, directories are themselves files that can be created, deleted, and moved. BTRON's file system uses a very different model called the real-object/virtual-object model. This system is a set of specifications designed to efficiently handle data in the BTRON operating system.

BTRON stores a collection of data in a *real object* referenced by multiple tags called *virtual objects*. A real object, like a conventional document, can contain text and figures in any combination. Real objects can also contain virtual objects (i.e., pointers to other real objects), a feature that provides a hypertext-like ability to structure data into its semantic components.

Virtual objects ordinarily appear as rectangles on a bit-mapped display (see figure 2a). These rectangles can be manipulated by selecting them with a pointing device. When a virtual object is opened (see figure 2b), it displays the contents of the real object it points to (in this case, a bit-mapped graphical figure of a clock).

In the real-object/virtual-object model, a real object is made up of ordered variable-length records of data, called segments. There are four standard types: text, figures, virtual objects, and *fusen* (a Japanese word pronounced "foo-sen" meaning "a stick-on label").

Text and figures are primitive segments for information transfer, and BTRON requires that the main text of an object be readable. This fact, plus the ability to nest virtual objects inside real objects, provides a simple hypertext-like feature as a basic component of the operating system.

There are two different types of real objects, with the difference lying in how the segments are stored within the real ob-

ject. In one type, called the one-dimensional real object (or "text" real object), segments are stored sequentially (see figure 3a). In the other type, called the two-dimensional real object (or "figure" real object), segments are arranged in a two-dimensional overlapped manner (see figure 3b).

Figure 4 summarizes the basic features of the real-object/virtual object model:

- Real-object data can be displayed in one or two dimensions.
- Viewports onto the real-object data can be nested.
- Real-object relationships are handled by a linked network of pointers.
- Objects are linked together by either virtual objects or opened virtual objects.

As with the Macintosh operating system, you can start a BTRON application by specifying a real object to be processed and letting the system determine the pertinent application. In this sense, the BTRON environment resembles the object-oriented systems that are being used on PCs and workstations.

In reality, however, the BTRON data model more closely resembles the conventional method of separating data and program because it also allows the opposite relationship: Different applications can be used for the same real object. This relationship is possible because a real object knows which applications can be invoked on itself. The knowledge is stored in the *function fusen* segment, which contains the parameters required for linkage to the application program.

With the basic editor, users can modify fusen and gain a variety of benefits, including the ability to specify default parameters and automatically invoke programs.

Efficient and free data compatibility between all computers is an important part of the TRON project. BTRON uses a model called the TAD (TRON application data bus) concept to provide for this data exchange. The purpose of the BTRON TAD protocol is to define the record structure corresponding to each segment in a real object. TRON applications should conform to the TAD protocol as much as possible. Therefore, a real object created by spreadsheet programs can be read by word proces-

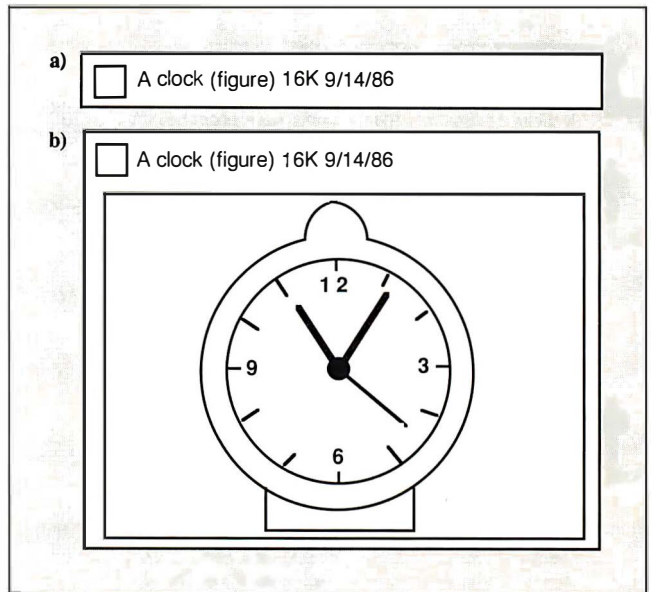

Figure 2: A BTRON virtual object is normally displayed as a rectangle (a), which, when opened (b), displays the contents of the real object it points to.

sors as numeric text data, or a real object created by graphical chart programs can be read by a graphics editor.

In conventional computers, general data compatibility is typically guaranteed only on the level of ASCII text. Spreadsheet data from Lotus 1-2-3, for example, can be loaded into most word processors or communications programs only after being stripped down into raw text, losing its essential numeric content. Graphical charts generated from that data become meaningless when converted into text this way.

Under BTRON, however, all data is divided into two parts: one that can be shared and one that is application-specific; the

continued

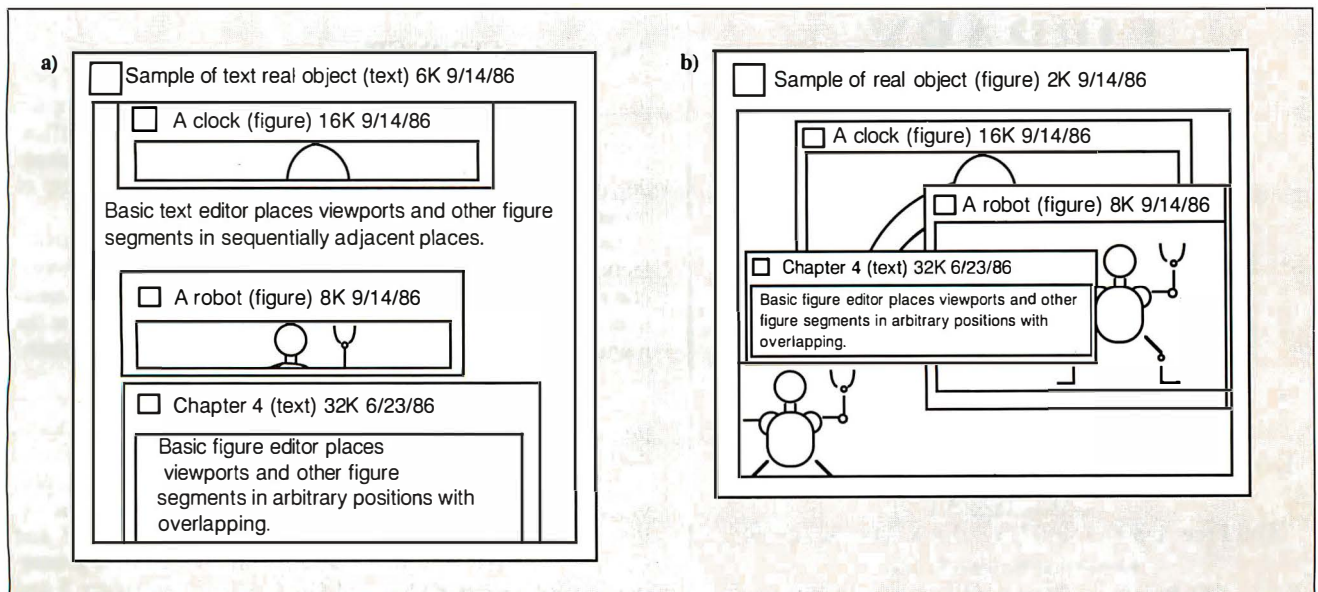

Figure 3: In BTRON, one-dimensional real objects (or text real objects) are stored sequentially (a), while two-dimensional real objects (or figure real objects) are arranged in a two-dimensional overlapped manner (b).

Compact Disk Products, Inc.

CD-ROM/WORM

ALL PRODUCTS, LOWEST PRICES, EXPERT ADVICE

INTRODUCTORY OFFERS

- Hitachi 1503S or 3500S CD-ROM Drive with your choice of:
- NEW Programmer's Reference Library (Microsoft) . . . \$995
 - McGraw Hill Science and Technical Reference Set . . . \$920
 - Grolier Electronic Encyclopedia . . . \$995
 - Microsoft Bookshelf or PCISG Library . . . \$895

CD-ROM SOFTWARE

- Oxford English Dictionary **NEW** \$945
- Comstock Stock Photography On CD . . . **NEW** \$445
- Educomp Public Domain/Shareware for the Mac . . . **NEW** \$179
- The New Grolier Electronic Encyclopedia . . . \$359
- McGraw Hill or Bookshelf or PCISG (Add \$25 for McGraw) . . . \$269
- The Bible Library \$495
- Kirk-Othmer Encyclopedia of Chemical Technology \$845
- Registry of Mass Spectral Data \$2655
- Geovision U.S. Atlas and Mapmaker \$795

TOLL FREE ORDER LINE • 800-MEGABYTE (634-2298)

CD-ROM and WORM DRIVES

- Hitachi 1503S External CD-ROM Drive with Audio \$729
- 1503S with Digital Audio Output and CD-Capture . . . \$1229
- Hitachi 3500S Internal 1/2 Height CD-ROM Drive w/Audio . . . \$719
- NEC Intersect CD-ROM Drives for the Apple/Mac CALL
- Maxtor 800 MB WORM Drive \$3899
- Portable 286 with CD-ROM Drive and Hard Disk CALL

CD-Play (\$89) Pop-up utility that permits user to play all audio CDs on Hitachi and compatible drives. Output to headphones or amplifier.

CD-PlaySampler (\$149) Same features as CD-Play plus the ability to name two points on an audio CD and loop between them.

CD-AudioFile (\$149) Automatically creates database records of all your audio CDs. Allows you to store a preferred play sequence for each disk. Automatic recognition of CDs. Creates DataBase compatible records.

CDP

Compact Disk Products
223 E. 85th St.
New York, NY 10028
Tel 212-737-8400
Fax 212-737-8289
CompuServe 75530,214

INTERNATIONAL ORDERS A SPECIALTY

International Agents:
United Kingdom
CDROM - New Manor Farm
Winterslow Near Salisbury
WILTS SP9 1SE
Tel. 0980-882890

Australia
Kewtel
145 Cotham Road
Kew, Victoria 3101
Tel. 03-817-5933

CDP now offers:
Consulting Services.
Call us for your
optical storage
solution.

THE TRON PROJECT

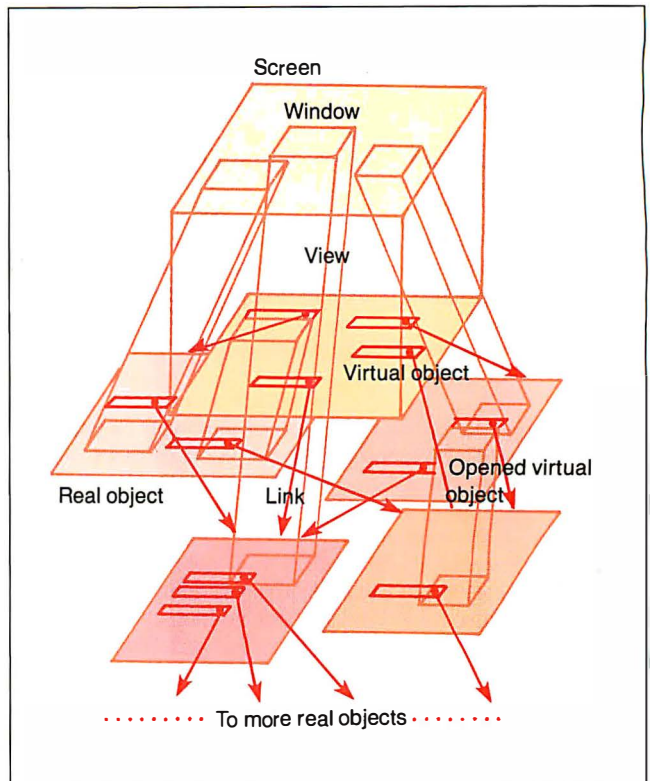

Figure 4: All BTRON data is stored in a real-object/virtual-object hierarchical structure. Real objects can be arbitrarily linked, and the virtual objects they contain can be nested to any depth.

DRIVER GURU™

The Most Comprehensive UNIX™ DRIVER LIBRARY EVER.

Whether you write UNIX Drivers or just want a better understanding of them, Driver Guru is for you!

- Provides expert assistance in applications modification
- Ensures accuracy whenever you write UNIX Drivers
- De-mystifies Unix Drivers forever!

UNIX is a registered trademark of AT&T

Driver Guru • \$ 95.00 • Limited Time Offer

CALL TODAY

Toll Free 1-800-433-9711 FAX 206-627-5934

Empirical Research, Inc.

P.O. Box 583 • Tacoma, Washington 98401

Open account available • MasterCard, VISA, American Express

ONLY FROM EMPIRICAL RESEARCH

shared data is standardized with TAD. Text and figures can always be shared among applications, so these are stored in distinct segments of the real object. Application-specific data, such as information describing the application and parameters necessary to read the data, are stored in fusen.

The Standard TRON CPU

One reason why there are efficient implementations of programming languages such as C and Pascal is that compiler companies build their systems according to common specifications and must therefore compete with one another. Multivendor implementations also encourage the wide development of programs written in the common language.

Exactly the opposite situation exists with current CPU architectures, where instruction sets typically have been held proprietary to the particular CPU manufacturer. This situation tends to discourage innovation in future CPU generations because the manufacturer must design its new CPUs to run with its customers' currently operating software.

The TRON project seeks to change this situation and has proposed a standard public domain CPU instruction set that is designed for efficient implementation of the TRON operating system. The current CPU architecture, called CHIP32, provides 32-bit addressing that is upwardly compatible with the 48-bit and 64-bit addressing modes for future CHIP48 and CHIP64 versions. Hitachi has already produced a first-generation version of CHIP32 called Gmicro/200 (see figure 5 and figure 6).

It is important to note that TRON bucks the recent trend toward RISC, headed by the SPARC from Sun Microsystems, and

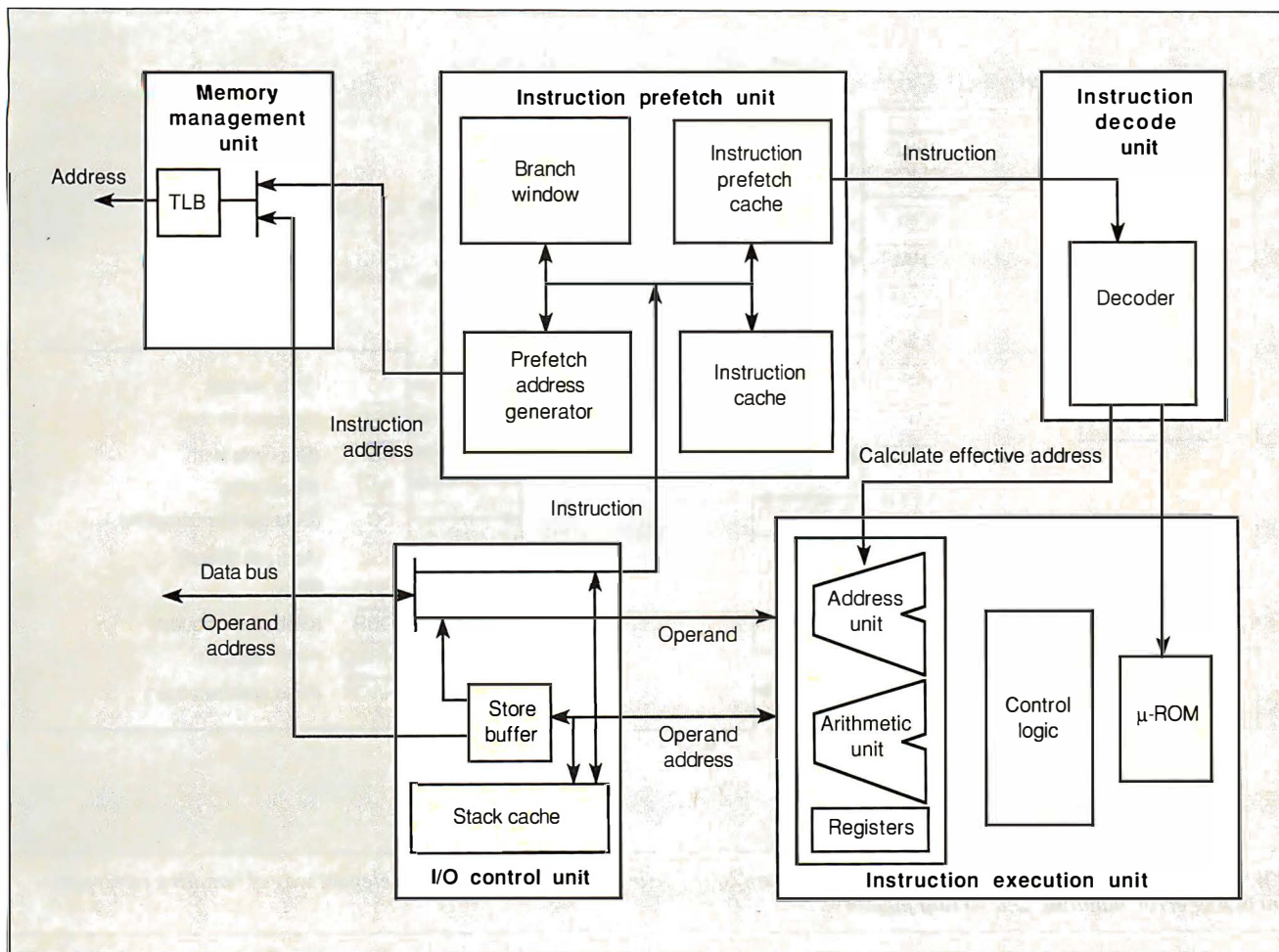

Figure 5: The Gmicro/200, the first generation of TRON CPUs, provides 32-bit addressing that is upwardly compatible with future 48-bit and 64-bit addressing modes. The internal structure of the Gmicro/200 provides for a very orthogonal instruction set. With the symmetry of operands, you can combine operands in any order.

similar systems from Hewlett-Packard and IBM. TRON instructions are very high-level, and CPU implementations of the TRON instruction set are among the most complex chips ever designed.

This is not to say, however, that TRON is a traditional CISC (complex-instruction-set computer). On one hand, it includes very high-level instructions designed to be useful for a compiler or an operating system. On the other hand, it has also shaved the length and speed of many of the most common instructions to make it compete favorably with RISC. In other words, it tries to combine the high-speed simplicity of RISC with the programming ease of CISC.

The TRON microprocessor is designed to be a general-purpose processor that is as suitable for high-level workstations as it is for small-scale embedded computers. Excellent performance (as compared to other processors, including RISC) is an important goal, but TRON's general-purpose role allows it to also benefit from easy-to-write and widely available development tools.

Compiler-Oriented Instructions

TRON's instruction set is designed to make it easier to develop high-level language compilers. Wherever possible, the format for operands is kept the same among all instructions, with a

minimum of special cases. Memory is treated as one contiguous address space, without segment registers. There are no distinctions between address and data registers, as there are in some processors.

To enable compilers to generate efficient object code, all registers are general registers having the same functions and the same length. Symmetry among instructions makes it much easier to allocate variables and programming work spaces, so TRON's instructions have been made as symmetrical as possible. All 16 general-purpose registers have the same functions, and many restrictions on sizes and available addressing modes have been removed.

In addition, there are two compiler-oriented instruction types not found on other processors: *chained addressing mode* and *arithmetic operations on different data sizes*.

The chained-addressing-mode function generates a complex addressing mode by combining a number of addressing primitives. For example, a sequence of instructions like

```
mov @(8,fp),r1
mov @(r1),r1
mov @(r1),r1
mov @(r1),r1
```

continued

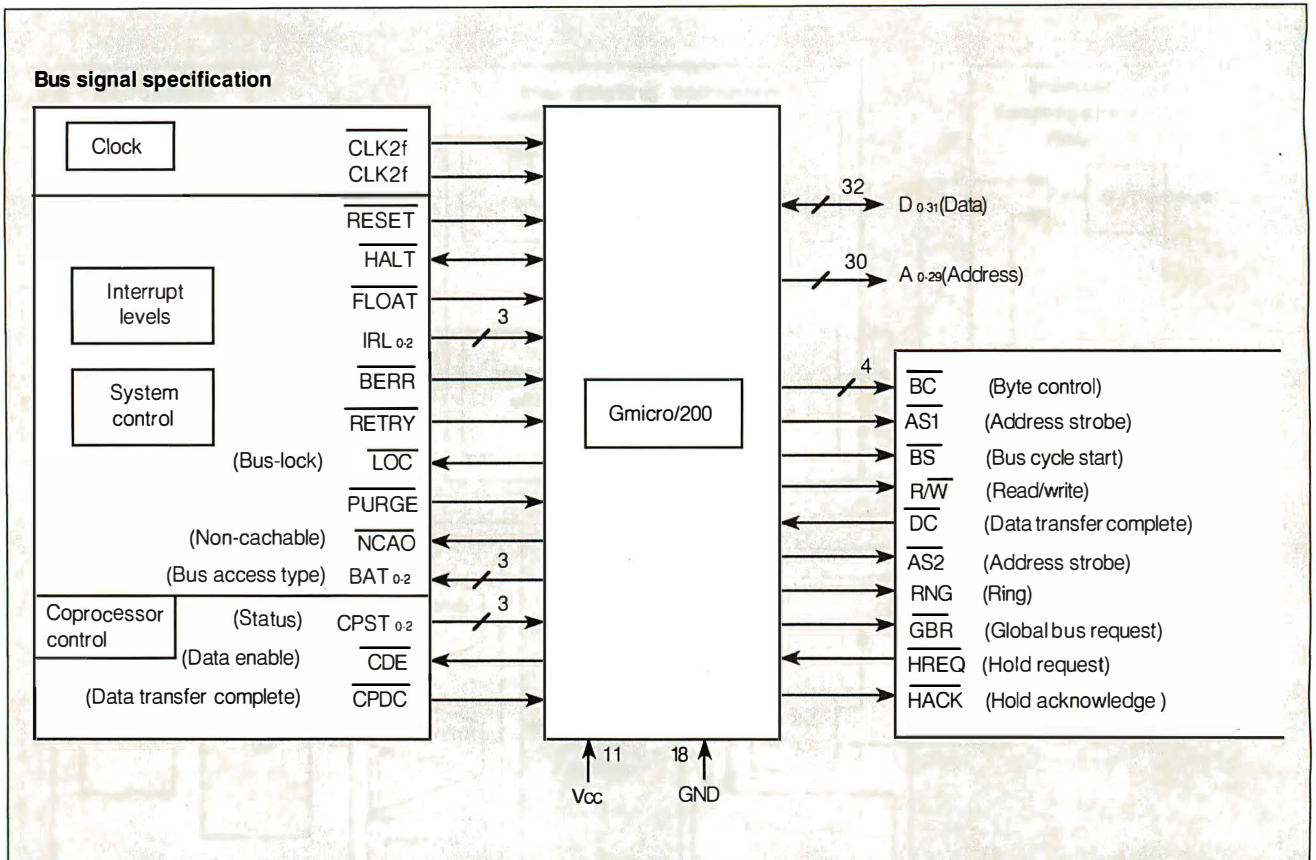

Figure 6: The bus signal specification for the Gmicro/200. The instruction set permits an elegant way of handling interrupts including error-handling and virtual memory.

can be replaced by the single instruction

```
mov @(@(@ (8, fp))), r1.
```

This feature can be especially effective for referencing between modules.

The arithmetic-operations-on-different-data-sizes function makes operand data symmetrical in size. With this facility, for example, 32-bit data can be multiplied by 8-bit data in a single instruction. This feature can be very useful in compiling a language like C, which frequently converts between data types. A processor without this function needs an additional instruction to expand smaller data to the size of larger data, which, in turn, requires a temporary register and further complicates register allocation in the compiler.

Operating System Support

Typically, CPU instruction sets are designed independently from any operating system. TRON's CPU, however, has been carefully designed with specialized instructions to support both the embedded computer requirements of ITRON and the high-performance workstation requirements of BTRON. There are high-level instructions for context switching (LDCTX and STCTX), for handling queues (QSCH, QINS, and QDEL), bit-map manipulation (BVPAT, BVMAP, and BVCPY), and string instructions (SSCH, SMOV, SCPY, and SSTR).

In other CPU architectures, many of these functions are handled by coprocessors. For example, bit-map functions are often handled by graphics coprocessors. But communication between

the main processor and the coprocessor requires a very wide data path, and the resulting overhead can cause performance problems. Since the TRON CPU was designed with its operating system software, there is no need to isolate graphics processing from other functions required by the chip. This makes bit-mapping functions a natural part of the instruction set.

The Implications of TRON

The huge American hardware and software markets have always been big enough that most developers have not considered the international market to be a potential starting point for new hardware and software standards. Japanese domination of the consumer electronics market, and a desire to provide highly functional distributed-systems capability to household products not limited to PCs, has created a standardization vacuum that led to TRON's Japanese origins.

U.S. software companies have already begun to explore TRON's potential as a way to export software to Japan, whose market still lags behind that of the U.S. by several years. Until BTRON, Japanese PC software was mostly limited to programs for MS-DOS-based personal computers (Apple's Macintosh has only 1 percent of the Japanese market). The possibility of a Japanese Macintosh-like competitor should open lucrative opportunities for American companies that are already old hands at designing efficient software that uses windows and pointing devices.

TRON is perhaps the world's most language-independent computer architecture, a situation that should make it much easier to port English-oriented software into Japanese.

Will TRON Succeed?

Janet J. Barron

The TRON concept sounds great: an open architecture that lets users freely shop for chips, components, and peripherals and includes common data-interchange standards that will make everything compatible with everything else. But how will the concept fare in the U.S., and what effect will it have on the computer industry?

John Roach, chairman of Tandy Corp., says that TRON's chances of overtaking the U.S.'s computer industry are very uncertain, although he admits that it's too soon to tell.

"There have been other efforts to develop more viable players, such as the MSX," says Roach. The MSX project was intended to make diverse software programs compatible with low-end home computers from different manufacturers. "Companies were going to make a set of compatible machines. That was the way they were going to attack the world market at the low end," Roach recalls. "That's pretty well gone today."

Besides, anybody who wants to try to build a new operating system is welcome to do so, says Roach. "The development of a new operating system is quite a challenge and takes a very long time. OS/2 is still trying to achieve that critical mass. Unix, I think, is still a relatively important competitor. I doubt that most of us appreciate its full potential. There's a tremendous amount of resources behind U.S. operating systems such as Unix."

About TRON's open architecture, Roach says, "Basically, MS-DOS and Unix are open architectures. Even if TRON becomes successful, it, too, will be limited by the constraints of its past." Since the TRON concept encompasses an open architecture, many domestic companies are deciding whether

or not to implement it or to run TRON applications.

Ron Waters, director of Streamlined Instruction Processors at Advanced Micro Devices, suggests that because of the growth of Japanese markets, TRON should be a major success there. With a ready-made educational market of 10 million computers alone, TRON's chances for success in Japan are assured. But, says Waters, "I don't think it will be a success in the U.S."

"Today we have capabilities for embedded processing that are competitive and offer excellent performance. Our innovative microprocessors and software continue to provide superior performance over any TRON chip that could be offered, and we have the capability to run TRON applications without the chips themselves," says Waters.

However, the fact that TRON encompasses VLSI chips, system software, and an open architecture prompted Larry Woodson, a strategist in Texas Instruments's semiconductor group, to say, "It has all the necessary elements for success: Complete software and tools are in development to allow the architecture to be marketed on a worldwide basis. In addition, the Japanese are developing an infrastructure by implementing TRON into some key end products. There is already working silicon and software available, so this is real."

Michael Dell, chairman and founder of Dell Computers, says his firm has no plans to use any of the TRON technology in its next generation of computers. "I don't think TRON will have much impact on microcomputers at this time. In this country, we have an intensely competitive market for microprocessors that drive computers. That market is based around standards that have already been set. As a processor engine,

TRON doesn't offer any specific advantages vis-à-vis processors from several of the other major U.S. companies." He added, "There's no basis to suggest the tariff situation will change to make it competitive for Japanese machines."

The Compatibility Question

Meanwhile, Japanese companies such as Mitsubishi, Fujitsu, and Hitachi have already implemented the TRON architecture, a task made easier by the TRON project's specification and standardization of the registers, the I/O, the instruction set, and addressing modes.

According to Charles Glenn, product-line manager for Fujitsu's 32-bit TRON Gmicro microprocessors and peripherals, the TRON project will certify the compatibility of the various implemented architectures with the TRON architecture. In essence, this certification will mean that the architecture can run all the TRON software. Many large Japanese silicon manufacturers endorse this architecture, said Glenn, and thus, "they will make it successful. The merits of the architecture are good."

But according to Jeff Nutt, technical marketing manager for CPUs at Motorola, TRON will not play an important role for at least one reason. "There will be different, and possibly incompatible, implementations by individual companies," says Nutt. "To make its products different from other companies' goods, a firm will do the same thing it does now—it will add its own special features or enhancements. These beefed-up products may be as incompatible as some competitive company's products are right now," Nutt says.

Janet J. Barron is a technical editor for BYTE. She can be reached on BIX as "neural."

TRON's presence is certain to be felt in the emerging educational market created by the Japanese ministry of education's recent announcement that all public schools must use computers. This order creates a market of up to 10 million machines by the mid-1990s. The lack of an easy-to-use Japanese counterpart to MS-DOS should further help its adoption by businesses, in the same way that, in its nascence, Apple succeeded with the Macintosh by creating new markets.

TRON's direct impact on the U.S. PC industry probably won't be felt for several years, although MTRON- and ITRON-compatible home appliances and consumer electronics will be

widely available in Japanese-made products much sooner. The fact that it will be easy to connect TRON PCs and TRON products could be an important step in giving TRON a growing share of the 1990s U.S. PC market.

Ken Sakamura, Ph.D., is the founder and director of the TRON project and is an associate professor of information sciences at the University of Tokyo. Richard Sprague has a B.S. in computer science from Stanford University and consults on issues related to the Japanese PC hardware and software markets. He can be reached on BIX c/o "editors" and "rsprague," respectively.



PS/2 model 30/286	1949
PS/2 model 50/30 meg	2795
PS/2 model 70/60 meg	3895
PS/2 model 60/71 meg	4100
PS/2 model 80/40 meg	4485
PS/2 model 80/115 meg	6595

Call for other models



386 S 40 meg	3595
386 20E - 40 meg	4595
286 40 meg	2195
386 110 meg/25 MHz	7495
386 60 meg/25 MHz	5895
Portable III 40 meg/12 MHz	4095

CARD & MONITOR EXTRA
Call for other models



Mac-SE/20 Meg	2849
Mac-II/40 Meg	4249
Mac-SE-20 DR	2295
Call for 60 and 100 Meg	
Lazer NT	3595
Lazer NTX	5195

LOW PRICE LEADER

SINCE 1983

LAP-TOP

Compaq SLT 286-20	Call
SLT 286-40	Call
Toshiba T1000	769
T1200F	1395
T1200HB	2395
T1600	Call
T3100E	Call
T3200-40 Meg	3495
T5100	4495
Zenith Supersport	
286-20 Meg	3195
286-40 Meg	Call
8088-20 Meg	Call
Epson LT	Call
NEC EL w/case	1295
Mitsubishi 286-20	2595



Everex

Step 286 - 12 & 16 MHz & 20 MHz
1 Meg RAM
Set up utility in ROM
S/P, C/C
Enhanced keyboard
1.2 MB floppy
DOS/BASIC

Call! for
your
configuration

Everex

Step 386-20 MHz & 16 MHz & 25 MHz
256K cache of very high speed RAM
2 Meg RAM, expandable to 16 Meg
S/P, C/C
Enhanced keyboard
1.2 MB floppy
DOS/BASIC
Everex 1800 Available

Call!



AST 286 model 140	2595
AST 286 model 80	1495
AST 386 model 300c	Call
AST 386 40 Meg	3495

CARD & MONITOR EXTRA
CALL FOR OTHER MODELS

WE STOCK

CITIZEN
OKIDATA
EVEREX
GOLD STAR

TOSHIBA
NEC
WYSE
HITACHI

PRINCETON GRAPHICS
SONY
ACER
HOUSTON INSTRUMENTS

AMDEK
HAYES
SAMSUNG
CALCOMP

PC MOUSE
MICROSOFT MICE
LOGITECH
MITSUBISHI

IRWIN & ARCHIVE
TAPE BACK
TAXAN
MAGNOVOX

BOARDS

Paradise VGA +	285
Vega VGA	279
Everex EVGA	265
Everex EGA	179
Tatung 16 bit	275

SOFTWARE SPECIALS

dBase IV	455
Wordperfect	239
Aldus Pagemaker	450
Ventura Publisher	475
Clipper	415
Quatro	145



NOVELL
Authorized
Dealer

PRINTERS

EPSON

LX-800/LQ-500	195/315
LQ-850/1050	535/735

OKI/OATA

320/321	359/490
390/391	490/649

TOSHIBA

321-SL/341-SL	475/595
351-SX 350 CPS	945

BROTHER

1709-9 PIN	425
1724-24 PIN	595

LASER PRINTERS

HP Laser II	1695
HP Desk Jet	675
Panasonic 4450	1549
Brother HL-8	2249
Nec LC 890	3295
PageLaser 12	\$\$\$\$\$

MONITORS

Nec Multisync IIA	525
Nec Multisync II	575
Nec Multisync Plus	949
Nec Multisync XL-19"	2295
Samsung EGA	335
Goldstar VGA	375

FAX MACHINES

Sharp FO 220	950
Sharp O2 350	1249
Canon OX350	Call
Brother	Call
Richo	Call
Murata	Call

Intel Coproprocessors

8087-3	105
8087-2	145
80287-6	175
80287-10	285
80387-16	409
80387-20	509
80387-25	649

MODEMS

Everex 1200 Int	89
Everex 2400 Int	159
Hayes 1200 B	275
More in Stock	Call

WE ACCEPT LC, CASHIER CHECKS, MONEY ORDERS, VISA, MC, AmEx
3% charge on VISA, MC & 5% on American Express

EXPORTS
Available

COMPUTERLANE

HOURS:
M-S 9-6

1-800-526-3482 (Outside CA)
(818) 884-8644 (In CA)
(818) 884-8253 (FAX)

22107 ROSCOE BLVD.
CANOGA PARK
1/2 BLOCK W. OF TOPANGA
CA 91304

CORPORATE ACCOUNTS WELCOME
CALL FOR VOLUME DISCOUNTS
CONSULTANTS CALL FOR PRICING

Prices subject to change without notice

Compaq is a Registered Trademark of Compaq
IBM is a Registered Trademark of International Business Machines

THE IBM PC BIOS

Specialized ROM routines form the heart of a standard

Recently a user on BIX asked some tough questions about IBM PC compatibles. "How can you tell if a clone of the IBM PC is really compatible?" he wanted to know. And, "How do you choose a BIOS for your machine to make it as compatible as possible?"

Alas, there are no easy answers to these questions. But this article—which takes a look inside the IBM PC BIOS—will give you an idea of what goes on inside a typical BIOS. I'll also present some ideas on how to test for compatibility and how to attain compatibility with protected-mode operating systems (which can't use the BIOS).

Perhaps no other single piece of commercial software has been more painstakingly studied, reverse-engineered, and cloned than the IBM PC's BIOS, or basic I/O system. This small set of control programs, which rarely consumes more than 64K bytes even in its most elaborate incarnations, is the key to making a system compatible with the IBM PC family—and to adding new features while retaining compatibility.

Roots: The CP/M BIOS

What is a BIOS? To understand the answer to this question, you must return to the ancient days B.P.C. (before the IBM PC) and look at what was perhaps the first commercially successful micro-computer operating system: CP/M.

CP/M (sometimes called CP/M-80 to distinguish it from other implementations) ran on the Intel 8080 and Z80 microprocessors and had two parts: the BDOS (basic disk operating system) and the BIOS. The BDOS, which was the ex-

clusive property of Digital Research, was the same in every implementation of CP/M, regardless of what hardware it was running on. The BIOS, by contrast, was tailored to the individual machine. The BDOS used the BIOS to access the terminal screen, read and write to the disk, and control the printer; the BIOS, in turn, gave machine independence to the BDOS.

The BDOS source code, as you might expect, was proprietary and was not published. However, the source code for each unique machine's BIOS was frequently available (in manuals, on BBSes, on the Internet network, and so on) so that users could understand and modify it as needed. Any weekend programmer could port CP/M to a new machine simply by creating a set of 17 short BIOS routines (typically only a few K bytes of code) and concatenating them with the BDOS on the disk. Because the relative locations of the BIOS and BDOS were exactly the same in memory as on the disk (one right after the other), they could be loaded together as one large "chunk" when the system was booted. Table 1 lists the original CP/M BIOS functions, and figure 1 shows how the BIOS and BDOS were laid out in RAM. The BIOS functions were entered through a *jump table* (a list of jump instructions).

The IBM PC, PC-DOS, and the ROM BIOS

One of the few problems with concatenating CP/M's BIOS and BDOS on the same disk was that you couldn't start one brand of machine from a disk intended for another (even if the disks were in the same format). When IBM adopted Microsoft's MS-DOS (derived from a CP/M look-alike called 86-DOS) as the primary operating system for its early PCs, it avoided this problem by moving the BIOS to a ROM within each machine, creating the new memory arrangement shown in figure 2. The result—at least in theory—was a system in which disks

could be freely exchanged between radically different types of hardware.

This approach might have been completely successful had early versions of the BIOS been highly optimized and fully featured in all areas. The IBM PC BIOS's disk functions, for instance, were quite fast, and programmers saw little need to bypass them. However, the BIOS screen functions in the original PC were slow, and some calls, such as those that controlled serial communications, were barely useful at all. In a few areas (e.g., sound), BIOS support was even lacking on the original PC. In these areas, programmers were forced to write code that manipulated the hardware directly.

Also, many programmers made use of memory locations used internally by the BIOS—locations that IBM was forced to maintain to keep new hardware compatible with the established software base. The result was a de facto "hardware/software" standard—consisting of BIOS calls, directly mapped storage locations, and peripheral hardware addresses—that remains prevalent to this day. While not as hardware-independent as IBM might have wished, this standard *has* been successful, and it has been implemented on a wide variety of machines, including laptops, diskless workstations, and even IBM's Micro Channel computers, which among compatibles represent some of the greatest departures from the original IBM PC architecture.

The ROM BIOS Services

The functions of the IBM PC ROM BIOS fall into several categories, each handled by its own software interrupt (see the text box "Software Interrupts and the 8086" on page 307). These categories include video, machine configuration, memory size determination, disk operations, serial communications, miscellaneous functions, keyboard control, the printer, invocation of BASIC in ROM (if present), bootstrapping the system, and system

continued

timer functions. (Other services, such as expanded memory and NetBIOS, are also activated via software interrupts but are not, strictly speaking, part of the main BIOS.)

Once the software interrupt for a particular category of functions has been invoked, the AH register—a byte-wide register within the 8086 CPU—is examined to determine the specific task to be performed. The other CPU registers hold additional information to be passed to the BIOS function. Since registers, rather

than the stack, are used to pass information to the BIOS routines, the information transfer is especially quick.

Table 2 gives a summary of the major BIOS services, grouped by function and software interrupt.

Video—INT 10h

The first BIOS software interrupt, INT 10h, controls the PC's video display. It allows you to put the display into text or graphics mode; select the number of characters, pixels, and colors that appear

on the screen; move the cursor; scroll the screen; plot pixels; and read or write characters. The EGA, PGA, VGA, and 8514 display adapters contain their own ROMs, which enhance and supersede the functions of the original BIOS ROMs; the enhanced functions allow application programs to select fonts, print the screen on the printer, change the color palette, and perform other graphics functions.

IBM later streamlined the video BIOS and added more functions (e.g., the AT has a function that can write more than one character to the screen at a time). But programmers couldn't wait for these enhancements to come along; they needed to have their programs run on every system, and they wanted more speed than they could get through the BIOS routines. They therefore adopted the practice of bypassing the BIOS and writing directly to the PC's memory-mapped screen. Because it is so common, this approach will work on virtually all compatible machines. However, in multitasking and windowing environments such as DESQview, programs that perform direct screen writes—often called "ill-behaved" programs—may not be able to share the screen gracefully with others. The Intel 80386's "virtual 8086" mode may help to contain such programs and force them to be "cooperative" in a multitasking environment, but the 80286 has no such mode. This is why the OS/2 compatibility box can currently run only one DOS application at a time.

Equipment Status—INT 11h

This software interrupt has only one function: to return information on the equipment attached to the PC. It returns a 16-bit word whose bits contain this information, as shown in figure 3.

Memory Size—INT 12h

This software interrupt also has only one function: to return the size of the computer's RAM (in K bytes) in the AX register. Extended memory (the memory above 1 megabyte) isn't included in this number.

Disk Operations—INT 13h

The INT 13h interrupt controls disk operations. Unlike the original CP/M BIOS, the IBM PC BIOS has a set of disk functions complete enough to eliminate the need for hardware-specific utilities. This has allowed the development of a wide variety of add-on disk controllers for the IBM PC; had there been a need to bypass the BIOS, it wouldn't be possible to add a new type of disk simply by adding a BIOS extension ROM.

Table 1: CP/M BIOS functions. These 17 routines, shown as they were arranged in the BIOS jump table, were all that were needed to adapt the CP/M-80 operating system to a new machine.

Jump table location	Name	Function
0	BOOT	Cold bootstrap.
3	WBOOT	Warm bootstrap.
6	CONST	Console (terminal) status.
9	CONIN	Console input.
12	CONOUT	Console output.
15	LIST	List device (printer) output.
18	PUNCH	"Punch" (paper tape) output.
21	READER	"Reader" (paper tape) input.
24	HOME	Move disk head to track 0.
27	SELDSK	Select a disk to read/write.
30	SETTRK	Set the disk track to read/write.
33	SETSEC	Set the sector to read/write.
36	SETDMA	Set memory location for disk data.
39	READ	Read a sector.
42	WRITE	Write a sector.
45	LISTST	Status of List device.
48	SECTAN	Translate logical sector number to physical.

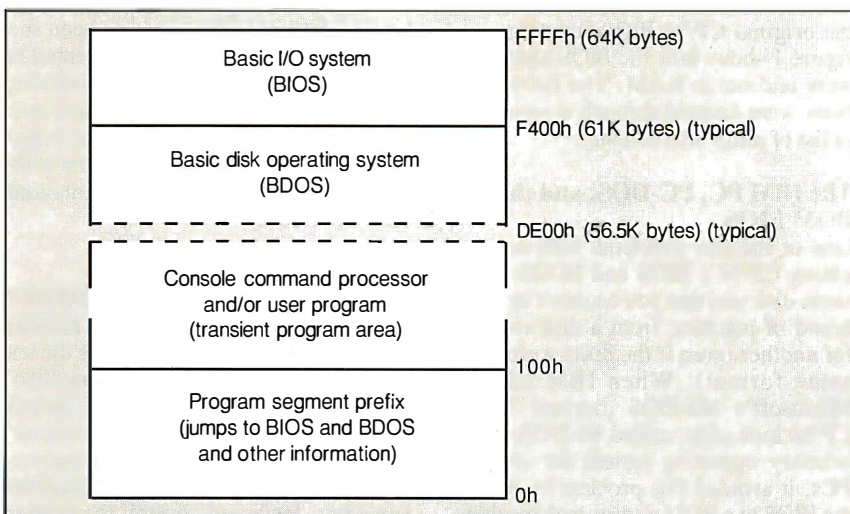

Figure 1: In CP/M, the BIOS loaded from disk together with the BDOS in a single chunk. Both resided in high memory above the user program.

Order **BYTE** and **BIX** on disk Today!

Full Text of BYTE on Disk

Now you can order disks containing the full, machine-searchable text of articles. You can read and search the text with any word-processor. Excellent for reference and research! Disks can be ordered singly or by annual subscription. Full text of BYTE is available starting from September 1988.

BYTE Program Listings on Disk

BYTE listings on disk are the right choice if you want to compile or read the complete source code listings of programs. BYTE listings are available from December 1985 to present at the prices stated below.

Best of BIX on Disk

Receive highlights of each month's activities on BIX—BYTE's world-class on-line conferencing system. You can read and search the text with any word processor. Each disk contains the most interesting and informative recent discussions specific to the machine you own. For example, order the IBM disk, and get the highlights from IBM-specific conferences. Disks can be ordered singly or by annual subscription.

BYTE also offers listings in print form. Order bound versions of the complete source code listings of programs excerpted from our articles. Handy for quick reference. Order singly or by annual subscription; with or without accompanying diskette version.

Call toll-free for more information: 800-258-5485.

ORDER FORM: To place your order, fill out the card and mail.

	IN USA		OUTSIDE USA	
	Single Month (1 disk)	Annual Subscription (13 disks)	Single Month (1 disk)	Annual Subscription (13 disks)
5-1/4 Inch: <input type="checkbox"/> IBM PC Other disk formats available. Call toll-free.	<input type="checkbox"/> Full Text of BYTE \$9.95 <input type="checkbox"/> BYTE Listings \$9.95 <input type="checkbox"/> Best of BIX \$9.95	<input type="checkbox"/> Full Text of BYTE \$79.95 <input type="checkbox"/> BYTE Listings \$79.95 <input type="checkbox"/> Best of BIX \$79.95	<input type="checkbox"/> Full Text of BYTE \$12.95 <input type="checkbox"/> BYTE Listings \$12.95 <input type="checkbox"/> Best of BIX \$12.95	<input type="checkbox"/> Full Text of BYTE \$99.95 <input type="checkbox"/> BYTE Listings \$99.95 <input type="checkbox"/> Best of BIX \$99.95
3-1/2 Inch: <input type="checkbox"/> Apple Macintosh <input type="checkbox"/> Atari ST <input type="checkbox"/> Amiga <input type="checkbox"/> IBM PS/2	<input type="checkbox"/> Full Text of BYTE \$10.95 <input type="checkbox"/> BYTE Listings \$10.95 <input type="checkbox"/> Best of BIX \$10.95	<input type="checkbox"/> Full Text of BYTE \$89.95 <input type="checkbox"/> BYTE Listings \$89.95 <input type="checkbox"/> Best of BIX \$89.95	<input type="checkbox"/> Full Text of BYTE \$13.95 <input type="checkbox"/> BYTE Listings \$13.95 <input type="checkbox"/> Best of BIX \$13.95	<input type="checkbox"/> Full Text of BYTE \$109.95 <input type="checkbox"/> BYTE Listings \$109.95 <input type="checkbox"/> Best of BIX \$109.95

FOR DIRECT ORDERING CALL TOLL FREE: 800-258-5485



Call: M-F, 8:30 a.m. to 4:30 p.m. Eastern Time
(603-924-9281 for New Hampshire residents)

For credit card orders only.



PLEASE COMPLETE IN FULL

APRIL

Name _____

Address _____

City _____ State _____ Zip _____

County or Parish _____ Country _____

Credit Card # _____ Exp. Date _____

Signature _____ Date _____

Please allow 4-8 weeks for delivery.

• Please indicate the issue date below. If you are beginning an annual subscription, note the starting issue.

Full Text of BYTE
Month _____ Year _____

BYTE Program Listings
Month _____ Year _____

Best of BIX
Month _____ Year _____

Check enclosed

MasterCard

VISA

U.S. funds enclosed
(If ordering from outside the U.S. please remit in U.S. funds drawn on U.S. bank. Thank you.)

Order **BYTE** and **BIX** on disk Today!

Full Text of **BYTE** on Disk

Now you can order disks containing the full, machine-searchable text of articles. You can read and search the text with any word-processor. Excellent for reference and research! Disks can be ordered singly or by annual subscription. Full text of **BYTE** is available starting from September 1988.

BYTE Program Listings on Disk

BYTE listings on disk are the right choice if you want to compile or read the complete source code listings of programs. **BYTE** listings are available from December 1985 to present at the prices stated below.

Best of **BIX** on Disk

Receive highlights of each month's activities on **BIX**—**BYTE**'s world-class on-line conferencing system. You can read and search the text with any word processor. Each disk contains the most interesting and informative recent discussions specific to the machine you own. For example, order the **IBM** disk, and get the highlights from **IBM**-specific conferences. Disks can be ordered singly or by annual subscription.

BYTE also offers listings in print form. Order bound versions of the complete source code listings of programs excerpted from our articles. Handy for quick reference. Order singly or by annual subscription; with or without accompanying diskette version.

Call toll-free for more information: 800-258-5485.

ORDER FORM: To place your order, fill out the card and mail.



NO POSTAGE
NECESSARY
IF MAILED
IN THE
UNITED STATES

BUSINESS REPLY MAIL

FIRST CLASS MAIL PERMIT NO. 10 PETERBOROUGH, NH

POSTAGE WILL BE PAID BY ADDRESSEE

BYTE & BIX on Disk

One Phoenix Mill Lane
Peterborough, NH 03458-9990



Interestingly, the AT disk BIOS did not support some functions listed in the documentation for the XT; these may have been intended for use with SCSI drives (which IBM has never sold for the PC line).

Serial Communications—INT 14h

The serial communications functions of the IBM PC BIOS are, alas, among its weakest points. Unlike all but the most basic communications programs, the BIOS serial routines do not use hardware interrupts to receive characters from external serial devices. This means that characters are likely to be “dropped” if a program on the PC does not constantly watch for their arrival.

As a result, virtually every program that uses the serial port (with the possible exception of print spoolers, which rarely receive characters) takes over the communications hardware and controls it directly.

Cassette/Joystick/Multitasking—INT 15h

Software interrupt 15h controlled the cassette tape interface and joystick port on the original IBM PC. However, since this interrupt was rarely used (the cassette interface was dropped entirely on the AT), IBM added new INT 15 functions, including support for multitasking, peripheral sharing, switching to protected mode, and detecting the use of the System Request key on the AT keyboard. The multitasking support functions are used only by some network programs, and OS/2 implements a faster mode switch than the standard BIOS does, so many of these functions are rarely invoked.

Keyboard—INT 16h

Software interrupt 16h manages the IBM PC’s keyboard. Keystrokes are returned as both ASCII characters and “scan codes”—codes directly related to the position of each key on the keyboard. Scan codes can help a program distinguish between two keys that send the same ASCII characters—for instance, the + key on

the main keyboard and the + key on the numeric pad.

BIOS keyboard functions are sometimes bypassed by utilities, like SuperKey, that remap the keyboard or enable and disable specific key sequences. Most application programs, however, use the keyboard as is.

Printer—INT 17h

This software interrupt provides three simple printer functions. It can initialize the printer port, check the printer status, or output a character to the printer.

BASIC—INT 18h

Most PC compatibles don’t implement a BASIC in ROM, as IBM PCs do. How-

ever, on machines that *do* have a BASIC, software interrupt 18h starts it running.

Bootstrap—INT 19h

Software interrupt 19h reboots the PC. Since this interrupt causes a “warm” boot, the BIOS doesn’t test memory; however, it does scan for ROMs containing extensions to the BIOS, as I’ll explain shortly.

System Timer—INT 1Ah

Software interrupt 1Ah allows a program to set and get the system time (measured in ticks). A tick occurs roughly 18.2 times per second, so there are exactly 65,536 ticks in an hour. On the AT, the

continued

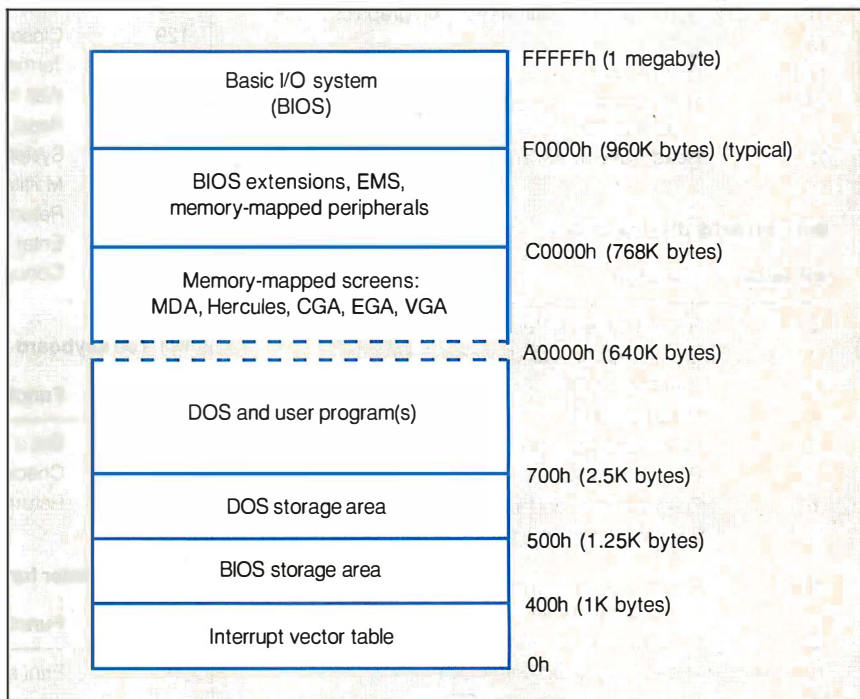

Figure 2: In the IBM PC, the high end of the memory-address space is reserved for the ROM BIOS, memory-mapped video, BIOS extension ROMs, memory-mapped peripherals, and expanded memory. The interrupt vector tables, BIOS storage area, DOS storage area, and DOS itself occupy the low end of memory. The user program loads between DOS and the memory-mapped screen area. Note that this memory layout gives rise to the infamous “640K barrier” that EMS, OS/2, and 80386 memory managers attempt to circumvent.

15-14	13	12	11-9	8	7-6	5-4	3-2	1	0
Printer	0	Game port? (0/1)	Serial ports (0-7)	0	Floppy drives (0-3)	Video mode	System board memory	8087	Floppy boot? (0/1)

Figure 3: The equipment configuration word, returned by the equipment status BIOS call, gives basic information on how the PC is equipped.

Table 2: Major IBM PC BIOS services.

INT 10h BIOS video functions

AH value	Function
0	Set video mode (0-6 for CGA, 7 for monochrome).
1	Set cursor shape (starting and ending lines).
2	Move the cursor.
3	Read cursor location and shape.
4	Read position of a light pen (seldom used).
5	Switch "pages" of display in text mode.
6	Scroll up.
7	Scroll down.
8	Read character and attribute at cursor.
9	Write character and attribute at cursor.
10	Write character at cursor.
11	Set color for medium-resolution graphics modes.
12	Write a pixel.
13	Read a pixel.
14	Write character to screen with rudimentary terminal emulation.
15	Read video mode and page.

INT 13h BIOS disk functions

AH value	Function
0	Reset the disk system.
1	Get status from last disk operation.
2	Read sector(s).
3	Write sector(s).
4	Verify sector(s) against memory.
5	Format a track.
6	Format a track and flag bad sectors (not on AT).
7	Format drive starting at a specified sector (not on AT).
8	Return parameters of current drive (heads, cylinders, sectors).
9	Initialize drive characteristics.
10	"Read long" (read with ECC).
11	"Write long" (write with ECC).
12	Seek to track.
13	"Alternate" disk reset.
14	Read sector buffer (not on AT).
15	Write sector buffer (not on AT).
16	Test if drive is ready.
17	Recalibrate the drive.
18	Controller RAM diagnostic (not on AT).
19	Drive diagnostic (not on AT).
20	Controller diagnostic.
21	Read drive type (fixed, floppy).

INT 14h BIOS serial communications functions

AH value	Function
0	Initialize a serial port.
1	Send a character.
2	Receive a character.
3	Read serial port status.

INT 15h cassette and multitasking functions

AH value	Function
0-3	Cassette functions.
4-127	Not used.
128	Open a shared device.
129	Close a shared device.
130	Terminate a task/program.
131	Wait for an event.
132	Read joystick position/switches.
133	System Request key.
134	Multitasking "wait" function.
135	Return size of AT extended memory.
136	Enter protected mode.
137-138	Concurrent I/O for multitasking systems.

INT 16h keyboard functions

AH value	Function
0	Get a keystroke.
1	Check for available keystroke.
2	Return status of Shift keys.

INT 17h printer functions

AH value	Function
0	Print a character.
1	Initialize the printer port.
2	Return printer status.

INT 1Ah time functions

AH value	Function
0	Read the system time.
1	Set the system time.
2	Read the CMOS clock.
3	Set the CMOS clock.
4	Read the date from the CMOS clock.
5	Set the date in the CMOS clock.
6	Set the "alarm" in the CMOS clock.
7	Reset the "alarm" in the CMOS clock.

time and date in the CMOS clock chip can also be written and read via this interrupt, and an "alarm" can be set to go off at a specific time.

Most current software does not use INT 1Ah to access the PC's real-time clock but inserts a service routine into a chain of routines called by interrupt 1Ch each time the timer ticks. Programs must be careful to remove themselves from this chain before terminating to avoid system crashes.

Bringing Up the System: POST and ROM Scan

Besides providing user-callable services, the ROM BIOS also performs general maintenance functions on the PC. When the system is first powered up, the BIOS performs a thorough check of the CPU, RAM, and ROM; it also looks for stuck keys on the keyboard and disk functions. Few parts of the PC escape scrutiny; if the power-on self test (or POST) is successful, it's likely that the machine is ready to boot.

After the POST, the ROM BIOS performs a function known as ROM Scan. The beginning of each 2K-byte block of memory between locations C8000 and E0000 is checked for a special signature; if the signature is found, the BIOS performs a checksum and executes a ROM at that location. This is the way peripheral board makers create "BIOS extensions" to accommodate new peripherals—a ROM on the board can initialize the peripheral, make it accessible via preexisting BIOS calls, and/or even interact with the user. This simple feature is one of the touches that make the IBM PC architecture truly "open" to peripheral vendors.

BIOS Variables

The area of PC memory from location 40h to location 50h contains storage locations that are reserved for use by the BIOS. While this area was not originally intended for use by application programmers, certain locations were so frequently accessed by user programs that IBM was forced to "freeze" their implementation to ensure compatibility with future machines. The information contained in the BIOS storage area includes:

- The number and locations of serial and parallel ports
- Equipment information (also accessible via INT 11h but frequently accessed directly)
- The keyboard queue
- Disk status information
- The system clock (often read

The IBM PC BIOS routines are called via 8086 instructions called *software interrupts*. Each instruction, represented by the mnemonic INT, carries a 1-byte interrupt number from 0 to 255 (FF hexadecimal). The interrupt number is an index into a *vector table*, a table in memory containing the 4-byte address of the service routine for each

interrupt. In figure A, an INT 10h instruction is used to call a BIOS video routine.

Most of the INT instructions are 2 bytes long, but one of them—INT 3—also contains a special single-byte encoding. You can take advantage of this variant when debugging or as a quick 1-byte subroutine call.

Software Interrupts and the 8086

Figure A: The number in an INT (software interrupt) instruction is used to find the address of an interrupt service routine in the 8086's interrupt vector table. In the IBM PC, this table normally starts at the very bottom of memory, with the INT 0 vector at location 0, INT 1 at location 4, and so on.

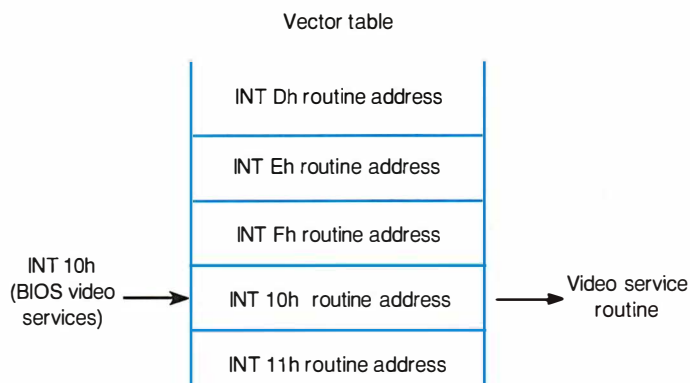

directly instead of through INT 1Ah)

- Information on the current video mode and cursor position

Many reference books now describe these locations in detail (see the bibliography).

Compatibility

One of the most common questions asked by prospective buyers of IBM compatibles is "How compatible is it?" (See the text box "The 'Clean Room' Approach" on page 308.) Alas, because the "standard" for compatibility is at best an ad hoc one, there is no easy answer to this question. Because it can, in many cases, hide hardware differences, the compatibility of the BIOS is one of the most important factors in determining the compatibility of the entire machine. But since software often bypasses the BIOS

and accesses the hardware directly, a well-coded BIOS is not a 100 percent guarantee of compatibility.

How do you test for compatibility? Traditionally, the standard measures of IBM compatibility have been badly behaved application programs. According to Samuel Adams Yorko, a BIOS compatibility expert, these programs include Microsoft's Flight Simulator, Lotus 1-2-3, XenoCopy, Microsoft Windows, Microsoft Word, Microsoft QuickC, DESQview, and early versions of Novell NetWare. TSR programs are excellent tests of compatibility. Copy-protected software, in its zeal not to be copied, tends to be quite finicky, and games in particular are good benchmarks because they cut corners to push the hardware and software to their performance limits.

Interestingly, as BIOSes have become more compatible, programs have also be-

continued

The "Clean Room" Approach

Makers of IBM PC compatibles have long feared lawsuits from Big Blue—especially after IBM was said to have threatened legal action against fledgling Eagle Computer for copying parts of the IBM PC BIOS. Amid the uncertainty and confusion that prevailed in 1983, Phoenix Technologies consulted lawyers and came up with a technique for creating a "legal" IBM-compatible BIOS: the so-called "clean room" approach.

First, Phoenix assembled two teams of programmers. The first became thoroughly familiar with the IBM BIOS and wrote a detailed specification explaining what the BIOS had to do to be compatible. A second team, consisting of

programmers who swore they had never seen a copy of the IBM PC BIOS, created a BIOS from that specification and sent it back to the first team. The first team checked the BIOS for compatibility and then modified the specification to cover areas that were missed on the first pass. All information that was exchanged by the two teams was monitored and recorded in the event of legal action.

After many cycles, the "clean" team (the programmers who had never seen the actual IBM BIOS) was able to produce a set of ROMs that was nearly 100 percent compatible with IBM's. Because these programmers had never seen the original IBM code, but only a

description of how it worked, Phoenix was confident that IBM would not be able to sue for copyright infringement.

To bolster this claim, Phoenix persuaded an insurance company to underwrite a "BIOS insurance policy" that would protect BIOS licensees from legal costs incurred in the event of an IBM lawsuit. While no policy was ever written, Phoenix's customers were apparently convinced that the approach was sound: There are more compatibles with Phoenix BIOSes than there are genuine IBM PCs in use today. Furthermore, despite questions regarding the originality of "clone" hardware designs, the originality of Phoenix's software has never been challenged in court.

come more well behaved. Newer versions of the programs mentioned above now run on more machines than ever, and the demise of copy protection has removed one of the major barriers to compatibility. Nowadays, it's relatively safe to assume that if a system runs a reasonable selection of TSRs, multitasking environments (e.g., OS/2, DESQview, Windows), and applications, it will be compatible with most other software. This convergence is due, in part, to economic necessity; because there are far more clones than there are "genuine" IBM PCs in the marketplace, it's in every software manufacturer's best interest to test products with the major compatible BIOSes (e.g., Phoenix, Compaq, AMI, and Award) before release.

Building Your Own BIOS

At one time, the art of building a compatible BIOS was shrouded in so much mystery that few dared to attempt it. At long last, though, those days appear to be over; dozens of books have now been published giving detailed information on the "innards" of the IBM PC BIOS. In fact, one—which arrived on my desk last week—gives the complete source code for an AT BIOS, largely written in C!

This book is worthy of special mention because of its novelty. *XT and AT BiosKits* from Annabooks (see bibliography) lets you create and customize a BIOS using only a C compiler, an assembler, and an EPROM programmer. Within an hour of assembling the required tools, I was able to burn a set of EPROMs and install them in my AT clone. As far as I could tell, the BIOS was fully com-

patible, and I was able to patch it to understand a new type of hard disk (not included in the standard tables) in only a few minutes. Other forms of "surgery" were equally straightforward. The Annabooks BIOS includes a resident monitor called SysVue that lets you peek at what's going on inside the system at any time—very handy for debugging the BIOS itself as well as other programs.

The Annabooks code is reasonably well commented, and it comes with a little gem that's very useful for PC-family programmers: the *XT-AT Handbook*. This pocket-size reference book is packed with information on DOS commands, the PC character set, I/O port addresses, interrupt vectors, RS-232C pinouts, and the PC hardware in general.

The literature that comes with the BIOS kit says that the authors will license the BIOS for use by any compatible manufacturer for \$4 a copy. At that price, they may get a lot of takers.

Exploring an Existing BIOS

If your hardware is close to 100 percent compatible with the IBM PC or AT, it's likely that many manufacturers' BIOSes (including IBM's, if you are able to get hold of some original ROMs) will run on it with no modifications. However, if your computer's architecture differs significantly from that of the IBM PC and AT, and you want to make BIOS modifications (or just see how it works), you may need to disassemble the existing code. Also, because IBM no longer provides BIOS source code in its *Technical Reference* manuals, disassembly may be the only way you'll be able to get a look at

what's going on inside the BIOS.

One painful but time-honored method of peeking into a BIOS is to trace through it with a debugger. DOS's DEBUG command will work for some of the less esoteric sections of the code; I've successfully used it to follow and understand the BIOS serial port services, for instance. But to trace through interrupt service routines and nonreentrant parts of the code, you'll need an in-circuit emulator—or a board like Atron's PC Probe, which performs a similar function.

Another less expensive approach is to purchase a disassembler explicitly designed to handle BIOSes. I recently used a product called Sourcer, made by V Communications of San Jose, California, to examine the BIOS of a PC-compatible coprocessor board with reasonably good results.

Sourcer, which can also disassemble standard .EXE and .COM files, comes with a very clever preprocessor that captures the BIOS *as it's running* on a machine. Besides looking at the code in the ROMs, the BIOS preprocessor looks in low memory for software and hardware interrupt vectors that point into the BIOS—identifying key entry points that might not be found otherwise. The preprocessor also takes snapshots of key variables within the BIOS's data area, so you can see the same values that the BIOS code might see while running. Everything the preprocessor identifies is neatly labeled in the disassembly listing.

No disassembler is perfect, though, and you'll probably find places where the disassembler mistook code for data (or the other way around). You can put the

disassembler back on track by modifying a control file to give explicit information about that area of the ROM.

At \$140, Sourcer with the BIOS preprocessor is a reasonably priced learning tool as well as a programmer's lifesaver. Just looking at the disassembled BIOS code is a real education and is highly recommended for the inquisitive.

ABIOS

The IBM PC BIOS is able, in many cases, to isolate programs that run in the "real" mode of the 8086 family of processors from the physical hardware—especially in certain areas such as disk I/O. However, it has few provisions for handling memory sizes greater than 1 megabyte and little support for the protected modes of the 80286 and 80386 processors. Thus, an environment that uses protected mode to multitask or to break the 640K-byte barrier on a standard AT compatible is forced to take one of two approaches: It can switch the processor back to real mode (slowly!) to use the IBM PC BIOS calls, or it can go directly to the hardware in protected mode, sacrificing the hardware independence provided by the BIOS.

To avoid this problem, IBM has come up with a new kind of BIOS: the Advanced BIOS, or ABIOS. (IBM sometimes calls the older, real-mode BIOS by the name CBIOS, or Compatibility BIOS, to distinguish it from the ABIOS.) ABIOS, which is currently implemented only on IBM's PS/2 series and compatibles, can be used by operating systems running in either real mode or protected mode—or by "bimodal" environments, like OS/2, that switch back and forth. ABIOS provides even greater isolation from the physical hardware than the original CBIOS and contains complete support for concurrent device access by many processes in a multitasking system.

Types of ABIOS Requests

ABIOS can support three types of requests made by an operating system or a user program: *single-staged*, *discrete multistaged*, and *continuous multistaged*. Each type of request is diagrammed in figure 4.

In a single-staged request, the ABIOS performs the requested function right away; it's done by the time the program regains control. A discrete multistaged request happens in two or more stages, with delays between the stages; the calling program regains control during the delays so that other processing can be done. A continuous multistaged request starts a staged operation that never ends.

Calling ABIOS

The ABIOS calling conventions reflect the needs of protected-mode and bimodal operating systems. ABIOS, unlike CBIOS, is entered by far calls rather than by software interrupts and is completely reentrant even between modes. That is, a real-mode function X can be interrupted and a protected-mode function Y started, even if X is identical to Y.

When a program or operating system calls ABIOS, it must pass pointers to two structures: a request block and a common data area (see table 3). The request block specifies the function to be performed—just as the interrupt number, the AH register, and the other CPU registers tell the CBIOS what needs to be done. The common data area, ABIOS's "master switchboard," is a table that contains pointers to all of ABIOS's other tables and data areas.

The internal data structures linked together by the common data area include function transfer tables—which, like CP/M's jump tables, list the addresses of routines that perform certain functions—and device blocks, which contain public and private information used by devices. The details of these complex structures can be found in IBM's *Personal System/2 Seminar Proceedings* (see bibliography).

When a program calls ABIOS, it must provide the segment or selector of the common data area and a pointer to a request block. Two other parameters may or may not be furnished by the caller, depending on the convention used. In the ABIOS Transfer Convention, ABIOS accepts just the addresses of the request block and the common data area and finds a function transfer table and a device block to use when handling the request. In the Operating System Transfer Convention, the caller furnishes the locations of these data structures. Note that since the parameters are not removed from the stack upon return to the caller, an operating system can save the function transfer table and device block addresses after they have been furnished by ABIOS during a call.

Interrupt Handling in ABIOS

Unlike CBIOS, ABIOS expects system devices to share interrupts. In a machine running under ABIOS, the operating system—not ABIOS—gets control when a hardware interrupt occurs. It is the responsibility of the operating system to call ABIOS to have the interrupt serviced, and the operating system must also issue the End of Interrupt command to the interrupt controller.

continued

Table 3: ABIOS stack frame and calling conventions.

Bytes	Stack contents
2	Common data area pointer (segment/selector only)—required.
4	Request block pointer—required.
4	Function transfer table pointer—furnished by ABIOS or caller.
4	Device block pointer—furnished by ABIOS or caller.
4	(Return address.)

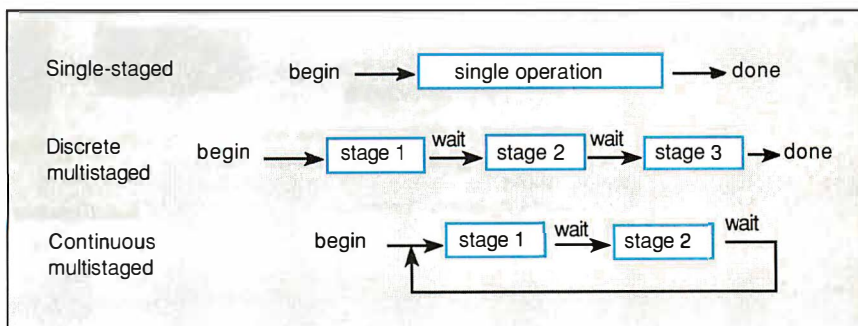

Figure 4: ABIOS request types. A single-staged ABIOS request completes immediately before returning to the caller. A discrete multistaged request is processed in stages with delays between the stages; control is returned to the caller until a hardware interrupt signals that a stage has completed. A continuous multistaged request starts a process—sometimes called a daemon—that loops forever between one or more stages.

If more than one device is sharing a hardware interrupt, the operating system must invoke the BIOS interrupt handling routine for each of these devices in turn. If the current interrupt does not affect a device, the operating system receives a return code from BIOS that says, "This is not my interrupt; please try another device." The operating system continues to query devices until one responds to the interrupt request.

Future Compatibility

BIOS is an important step toward maintaining machine independence in the Intel protected-mode world. Unfortunately, the majority of PC compatibles available today—and likely to be available in the near future—do not have BIOS, and users of multitasking operating systems such as OS/2 and Unix must buy machine-specific versions of the operating system and/or install device drivers to adapt the operating system to each machine.

There is no compelling technical reason, however, why BIOS cannot be added to existing systems—as an add-in ROM or even as a TSR. (In fact, IBM has

stated publicly that "BIOS is contained in ROM but does not preclude a RAM implementation.") It is to be hoped that, in the long term, compatible manufacturers (and/or enterprising software designers) will provide BIOS implementations for existing 80286 and 80386 machines. If this does happen, you can anticipate an even greater level of standardization and machine independence than that engendered by the original IBM PC BIOS.

In the meantime, the venerable IBM PC BIOS—now well understood and readily implemented—has fostered the development of a strong, consistent industry standard. While far from perfect, this standard will doubtless persist for another decade or more and will allow manufacturers to produce quality products at commodity prices. Hopefully, newer standards, such as BIOS, will eventually replace the standard CBIOS as the basis for compatible machines with multitasking and more than 640K bytes of directly addressable memory. Only time will tell if these new standards will ever be as pervasive as the standard that lies at the heart of the IBM PC. ■

BIBLIOGRAPHY

- Davies, Russ. *COMPUTE's Mapping the IBM PC and PCjr*. Greensboro, NC: COMPUTE! Publications, Inc., 1985.
- Foster, John O., and John Choisser. *XT and AT BiosKits*. San Diego, CA: Annabooks, 1988.
- IBM PC, XT, and AT *Technical References* (several revisions). Armonk, NY: IBM, 1981-1987.
- IBM Personal System/2 Seminar Proceedings*, vol. 5, no. 4. Armonk, NY: IBM, 1987.
- Norton, Peter. *The Programmer's Guide to the IBM PC and Compatibles*. Redmond, WA: Microsoft Press, 1988.

ACKNOWLEDGMENT

Special thanks to Samuel Adams Yorko for his help in obtaining information.

Brett Glass is a freelance programmer, author, and hardware designer residing in Palo Alto, California. He can be reached on BIX as "glass."

Your questions and comments are welcome. Write to: Editor, BYTE, One Phoenix Mill Lane, Peterborough, NH 03458.

It's Your Move...



► INTELLIGENCE

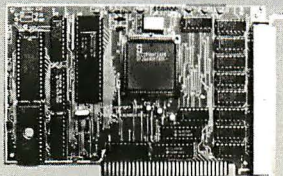

MODEL PCSS-8I OCTAL SERIAL COMMUNICATION CO-PROCESSOR

- 8 Co-processor driven RS232 channels/card.
- BIOS Enhancement Software included.
- Eliminates host processor overhead.
- 32-2048KByte buffer memory.
- May be used standalone in custom appl.

► VERSATILITY

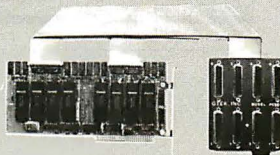

MODEL PCSS-8X MULTIPOINT SERIAL BOARD

- 8 RS232 ports per card (opt. 4 port).
- All 8 ports 100% DOS compatible.
- 32 ports may be added to a PC.
- Optional RS422 to 4000 ft.
- Interrupt driven BIOS Enhancement Software included.

► HIGH PERFORMANCE



MODEL 9000 (E)EPROM MPU PROGRAMMER

- Fastest programmer on the market.
- Quick & Intelligent programming algorithms.
- Supports megabit eproms.
- Programs largest variety of chips.

► TIME SAVING



MODEL ROMX-2XL EPROM EMULATOR

- Emulates 2716-27010 eproms.
- 256K to 1024K memory available.
- Battery backed up, auto emulate on power-up.
- Low-cost, pays for itself on first project.
- Free 19.2K Serial Communications Software.

If Intelligence, Versatility, High Performance and Time Saving products are what you're looking for, make that move today and let GTEK® put one, two, three or all four of these products to work for you! Remember, other development products are available. — CALL!



DEVELOPMENT HARDWARE & SOFTWARE
P.O. Box 2310; Bay St. Louis, MS 39521-2310 U.S.A.
ORDER TOLL FREE 1-800-255-GTEK(4835) FAX: 1-601-467-0935
MS & Technical Support 1-601-467-8048



FLOATING-POINT REVISITED

This variation on a theme yields a floating-point package particularly suited to business applications

Floating-point is a topic of sufficient significance for me to cover it more than once, particularly when there's some ground that I didn't cover last time (see my two-part "Floating-Point without a Coprocessor" in the September and October 1988 BYTE). This month's package is fundamentally different from the previous one—it has strengths where the other has weaknesses, making it particularly suited to business and accounting applications.

The floating-point package that I described in "Floating-Point without a Coprocessor" manipulated floating-point numbers in base 2; such numbers are called binary floating-point numbers. This time, I'm presenting a binary-coded-decimal (BCD) floating-point package. As you'll see, BCD floating-point computing has some advantages over binary floating-point computing. (Borland includes a BCD option in its Turbo Pascal programming language, and Zedcor uses a BCD representation for floating-point numbers in its ZBasic compiler.)

But it's not all roses. There are some disadvantages to using BCD floating-point numbers. That's part of life in the computer world. This column should help you decide which form—BCD or binary—is best for your applications.

Inside

I can describe the format of a BCD floating-point number easily. (You'll catch on even quicker if you've read my earlier ar-

ticle on floating-point.) Take a look at figure 1 and see if you recognize the structure. FAC1_EXP holds the exponent, FAC1_SIGN contains the sign of the number, and FAC1_MAN holds the mantissa.

The main difference between a binary floating-point number and a BCD floating-point number is that the binary number is in base-2 representation while the BCD number is still in base 10. A binary floating-point number looks like this:

$$\pm a \times 2^b$$

where a is the mantissa and b is the exponent. In the case of most floating-point formats in use today (e.g., the IEEE formats and the one I presented in "Floating-Point without a Coprocessor"), a is interpreted as a binary fraction, and b is an integer.

In contrast, a BCD floating-point number has the following form:

$$\pm a \times 10^b$$

Now, a is a decimal fraction in BCD notation; b is still an integer, but this time it indicates a base-10 exponent. But how is a number stored in BCD notation? The process is simple: Take each decimal digit in the number, convert that digit into its 4-bit binary equivalent, and store each 4-bit packet into successive nibbles of the BCD number. So, 32 base 10 would be 00110010 base 2; 458 base 10 would be 010001011000 base 2.

Actually, I'm being needlessly difficult. If you convert a base-10 number into its BCD equivalent and display the results in hexadecimal, it looks just like the original number. So, 458 base 10 converted to a BCD number and displayed in base 16 is just 458. Each decimal digit is stored in 4 bits—exactly the number of bits required to store a hexadecimal digit. (This is particularly nice when you're in a debugging session: You can determine a BCD floating-point

number's value on sight. Try that with a binary floating-point number!)

In my September column, I introduced the idea of a *bias* in regard to the exponent. You can think of the bias as an offset that allows the exponent to represent both positive and negative values. This BCD floating-point package uses a bias of 16384; the true value of the exponent is FAC1_EXP - 16384. This translates to a range of ± 16383 for the exponent. An exponent of 0 is a special case that indicates true zero, allowing routines to test for zero by looking at a single word rather than having to scan the entire contents of the mantissa.

So what do all these attributes buy you? First, since the BCD floating-point number is in base 10, you don't lose any precision when converting numbers between their external form (ASCII strings on the display) and their internal representation. As a contrasting example, the binary equivalent of 0.1 is a repeating binary fraction, just as the decimal number for $\frac{1}{3}$ is 0.333333... Consequently, 0.1 cannot be precisely converted into a binary floating-point number. Happily, BCD floating-point numbers do not suffer from such rounding errors: 0.1 is easily stored as a BCD floating-point number with no precision loss. On the other hand, BCD floating-point numbers suffer from truncation errors: The number is simply snipped off at the least-significant digit.

Another drawback to using BCD floating-point numbers is that the four basic arithmetic routines are slower than their binary counterparts. This is because you can't use the base number system native to the machine (base 2). Designers of the 8088 (and other popular CPUs) have incorporated special instructions for working with BCD numbers, but these instructions tend to be, shall we say, less robust than their binary counterparts. BCD instructions operate on byte-size quantities only, so you can-

continued

Listing 1: Pseudocode for BCD floating-point addition and subtraction.

```
{ Add the contents of FAC1 to the contents of FAC2. The result is
{ returned in FAC1.
FADD:
  IF FAC2_EXP > FAC1_EXP THEN
    Swap FAC1 and FAC2;
  N := FAC1_EXP - FAC2_EXP;
  { N is the difference between the two exponents; i.e., the number
  { of times we have to multiply FAC2 by 10. This multiplication is done
  { by shifting, and if we have to shift more times than there are
  { digits, the number is already in FAC1.
  IF N > NUMBER_OF_DIGITS THEN
    RETURN no error;
  REPEAT N TIMES
    SHIFT FAC2_MAN right 1 nibble;
  IF FAC1_SIGN = FAC2_SIGN
    { The following is a BCD addition.
    FAC1_MAN := FAC1_MAN + FAC2_MAN;
  ELSE
  BEGIN
    { The following is a BCD subtraction.
    FAC1_MAN := FAC1_MAN - FAC2_MAN;
    IF borrow occurs THEN
      BEGIN
        FAC1_SIGN := FAC1_SIGN XOR 80H;
        { The following step may only be necessary on the 80x86 family-
        { thanks to the way it performs BCD operations. To negate the
        { mantissa, set the carry and perform a BCD subtraction from 0.
        Negate FAC1_MAN;
      END
    GOTO NORM_FAC1;
  { Subtract contents of FAC2 from contents of FAC1. Result in FAC1.
  FSUB:
    FAC2_SIGN := FAC2_SIGN XOR 80H;
    GOTO FADD;
```

not take advantage of a 16- or 32-bit register. In contrast, a binary floating-point package written specifically for an 80386 or 68000 would perform approximately half the register-to-memory fetches than would an equivalent BCD package on, say, an 8088.

There is a final saving grace for BCD. As I've mentioned, I/O of BCD floating-point numbers is tons simpler and quicker than I/O of binary floating-point numbers. If you review "Floating-Point without a Coprocessor," you'll see that the input and output routines have to perform floating-point multiplication and division by 10; they're time-consuming operations. With BCD floating-point numbers, I/O isn't much more than a series of shift and mask operations. No multiplications are involved.

Addition

You may recognize the similarity between these algorithms and the ones that appeared in my previous discussion of floating-point; if not, you should still have no trouble following the discussion, thanks to the fact that this BCD package lets you work in base 10. These routines

use a set of floating-point accumulators (memory locations, actually) to hold the factors of operations taking place. FAC1 and FAC2 are the primary accumulators; FAC3 operates as a temporary holding location. The results always appear in FAC1.

The first step in the BCD floating-point addition routine (see listing 1) is to align exponents (equivalent to aligning decimal points when adding numbers on paper). FADD moves the factor with the largest exponent into FAC1 and then subtracts exponents to determine how many times it is necessary to increment FAC2's exponent to align it with FAC1's. Incrementing FAC2's exponent is offset by dividing FAC2's mantissa by 10; actually, the exponent of FAC2 is never incremented since all that is needed is FAC2's adjusted mantissa. Once the two factors are aligned, FAC1 can provide the exponent, because both exponents are now equal.

This is where BCD floating-point numbers and binary floating-point numbers show their differences: A single shift of a binary floating-point mantissa multiplies or divides (depending on the direction of the shift) the number by 2.

Shifting a BCD floating-point mantissa left (or right) by a nibble multiplies (or divides) that number by 10. See the symmetry? The operations are the same; only the bases have changed.

There is the possibility that, in order to align exponents, FADD might have to shift FAC2's mantissa to the right more times than FAC2 has significant digits. In other words, FAC2's magnitude may be negligible relative to FAC1's magnitude—at least within the accuracy of this BCD package. In this case, FADD simply exits without changing the contents of FAC1.

Once the exponents are equal (i.e., the decimal points are aligned), the routine can do the addition. Actually, it may not always be addition; the routine will need to do subtraction if the mantissas' signs are different. If the routine ends up subtracting the numbers, then, on the way out the door, it makes a final check to see if a borrow (subtraction's counterpart to addition's carry) has been generated. A borrow indicates that the sign of the result is opposite FAC1's sign; in other words, FAC1 was a positive number, and FAC2 is a negative number with an absolute value greater than FAC1. Since FAC1 now holds the result, the routine flips its sign accordingly. Finally, the FADD exits through the normalization routine.

Normalization

Normalization preserves a high accuracy for floating-point numbers. Simply put, when you normalize a floating-point number, you move its most-significant digit just to the right of the decimal point. Instead of storing 270 as $.00027 \times 10^6$ (and wasting space on all those zeros), you normalize the number and store it as $.27 \times 10^3$. So normalization simply boils down to multiplying or dividing the mantissa by powers of 10 while incrementing or decrementing the exponent, thereby leaving the value of the number unchanged. You've already seen that multiplication and division of the mantissa can be accomplished by shift operations. The pseudocode for normalization uses the same concepts and should therefore be pretty easy to understand (see listing 2).

Keep in mind that two memory representations of numbers are at play in this package: the internal representation (how the number is stored in the floating-point accumulators) and the external representation (how the number is stored in the local memory of an application). These representations are different, and for good reason. When numbers are be-

ing processed by the floating-point package, you are concerned primarily with maintaining accuracy. Space conservation is no real issue; at most, only two numbers are being manipulated at a time. Outside, in the application program that is calling the floating-point package, memory space may be a serious consideration.

For example, the number 0.4332198, normalized and stored in FAC1, would look like this:

0433 2198 0000 0000 0000 0000

Notice that when the number is in internal form, it is shifted to the right one digit. This leaves an empty "overflow" slot that catches any carries (or borrows) out of the most-significant-digit position. Also, the internal representation carries an extra word at the number's least-significant digits (see figure 1). This padding becomes important as numbers are shifted to the right to align exponents for the addition operation; some of the least-significant digits are retained, rather than being shifted off into never-never land.

Subtraction

This is as easy as ever: Flip the sign of FAC2 and call the FADD routine.

Multiplication

In multiplication, the speed advantage of a binary package over a BCD package begins to show through. Multiplication is actually a series of shift-and-add operations. In the binary floating-point package, an addition takes place for each 1 bit in the multiplier. But in this BCD package, the number of additions that takes place is equal to the sum of the multiplier's digits.

Let me illustrate. When the BCD package goes to multiply 15 and 34, it first sets up a product memory location, initialized to 0. Then, it looks at the rightmost digit of the multiplier (4 in this case), which indicates the number of times to add the multiplicand into the product. So the partial product in step 1 is $15+15+15+15=60$. Then the routine examines the multiplier's next digit to the left (3), which is the number of times to add the multiplicand *times 10* into the partial product. So the result in this example is $60 + (150+150+150)$, or 510. For a bigger multiplier, this process would repeat with the multiplicand times 100, times 1000, and so on.

Put another way, the routine is repeatedly multiplying the multiplicand by 10

continued

Listing 2: Normalizing a BCD floating-point number.

```
{ Normalize the floating-point number in FAC1.
NORM_FAC1:
  IF FAC1_MAN = 0 THEN
    BEGIN
      FAC1_EXP := 0;
      FAC1_SGN := 0;
      RETURN no error;
    END
  IF highest nibble of FAC1_MAN <> 0 THEN
    BEGIN
      Shift FAC1_MAN right 1 nibble;
      FAC1_EXP := FAC1_EXP + 1;
      IF high bit of FAC1_EXP <> 0 THEN
        RETURN exponent overflow;
      END
    WHILE highest nibble of FAC1_MAN = 0
      BEGIN
        Shift FAC1_MAN left 1 nibble;
        FAC1_EXP := FAC1_EXP - 1;
      END
    IF high bit of FAC1_EXP <> 0 THEN
      RETURN exponent underflow;
    ELSE
      RETURN no error;
```

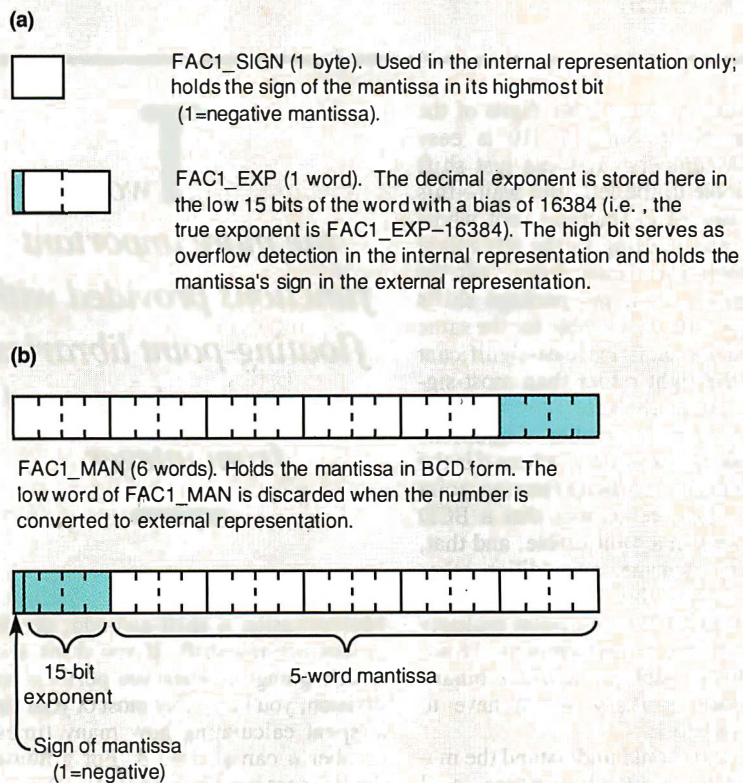

Figure 1: (a) A BCD floating-point number's internal storage (i.e., when the floating-point package is operating on the number), and (b) its external storage, as seen by the calling application. This format can handle numbers in the range $\pm n \times 10^{\pm 16383}$, where n is a decimal fraction with 20 digits of precision.

Listing 3: Pseudocode for the multiplication algorithm.

```
{ Multiply contents of FAC1 and FAC2. Result in FAC1.
FMUL:
  IF (FAC1_EXP = 0) OR (FAC2_EXP = 0) THEN
    BEGIN
      FAC1_MAN := 0; { Clear the mantissa
      GOTO NORM_FAC1;
    END
    { Calculate exponent of result.
    FAC1_EXP := FAC2_EXP - BIAS + FAC1_EXP;
    IF high bit of FAC1_EXP = 1 THEN
      RETURN exponent overflow error;
    { Determine sign of the result.
    FAC1_SIGN := FAC2_SIGN XOR FAC1_SIGN;
    { Copy FAC1's mantissa to FAC3 and clear FAC1's mantissa in
    { preparation.
    Copy FAC1_MAN into FAC3_MAN;
    FAC1_MAN := 0;
    REPEAT number_of_digits times
      BEGIN
        N := lowest nibble of FAC3;
        REPEAT N times
          { NOTE: The following statement adds two BCD numbers.
          FAC1_MAN := FAC2_MAN + FAC1_MAN;
          IF this is not last time through REPEAT loop THEN
            BEGIN
              Shift FAC1_MAN right 1 nibble;
              Shift FAC3_MAN right 1 nibble;
            END
          END
        END
      GOTO NORM_FAC1;
```

while scanning through the digits of the multiplier. Multiplying by 10 is easy with BCD numbers: You can just shift them 1 nibble to the left. But wait—this package uses BCD fractions, not whole numbers, and shifting to the left might roll the most-significant digits “off the top.” Instead, then, the package shifts the product right by 1 nibble for the same effect, and you sacrifice least-significant digits on the right rather than most-significant digits on the left.

So the maximum number of additions that can take place is $9 \times d$, where d is the number of digits in a BCD floating-point mantissa. Now, remember that a BCD digit is stored in a 4-bit nibble, and that, in a binary package, an addition takes place for every 1 bit. You can see that, *per byte*, a BCD floating-point multiply routine may have to perform up to 18 additions (9 per nibble), while a binary floating-point multiply would have to perform 8 at most.

By now you should understand the mechanics of the multiply routine, so I won't go into great detail concerning its pseudocode in listing 3. About the only thing I've left out is how the routine determines the sign of the result. And that's easy: You do an EXCLUSIVE-OR on the signs of the two factors.

Two of
the more important
functions provided with
floating-point libraries
are conversion to and
from integer.

Division

Multiplication is shift-and-add; division is subtract-and-shift. If you think about what's going on when you perform long division, you know that most of your time is spent calculating how many times a number a can go into b . For a human, this process is a set of heuristics that usually involve eying the number and taking educated guesses. For a computer, the process is cruder: Keep subtracting a from b until b is less than or equal to 0, and keep track of how many times you perform the subtraction. There—now

you know the core of the division algorithm (see listing 4).

It is easy to dissect the other parts of the routine. To determine the sign of the quotient, you use the same technique as in the multiplication routine: You do an EXCLUSIVE-OR on the sign bytes of the factors. Make sure you're watching for a 0 in the denominator (FAC2 in this package), and bail out with an error condition if you see one. Finally, if the numerator (in FAC1) is 0, the routine can exit without having to do any work since the result is already in place.

Conversions

Two of the more important functions provided with floating-point libraries are conversion to and from integer. In the interest of completeness, I include them in this package.

Listing 5 shows the pseudocode for converting a 16-bit integer to a BCD floating-point number. This routine is primarily a process that pulls decimal digits out of the integer number one at a time, shifting each digit into the mantissa and incrementing the exponent for each digit shifted in. You can extract digits from an integer by repeatedly dividing that number by 10 and examining the remainder after each division.

Since a 16-bit number can hold, at most, five decimal digits, the routine need not concern itself with overflow checks. The only extra test is for the sign, at the start of the routine.

Getting a number back to integer from the floating-point format is another matter. There are two possible situations in which the conversion will fail. In case 1, the number is too large to fit into a 16-bit signed integer (whose range, by the way, is ± 32767); in case 2, the number has no integer part—that is, it's something like 0.001.

Strictly speaking, case 2 doesn't cause a failure; the routine simply returns a 0 for the result. Handling case 1 is trickier. You can get a quick idea of whether or not the floating-point number will fit by examining its exponent. When FAC1_EXP - BIAS is a positive number, the result is the number of digits to the left of the decimal point. Consequently, if FAC1_EXP - BIAS is greater than 5, the routine can exit immediately: The number is surely too big. Otherwise, checking for overflow has to proceed as the number is converted to integer.

The routine multiplies an accumulator by 10, shifts the topmost digit out of the mantissa, and adds this digit to the accumulator. (The number of digits to shift

continued

A MESSAGE TO OUR SUBSCRIBERS

FROM TIME TO TIME we make the BYTE subscriber list available to other companies who wish to send our subscribers material about their products. We take great care to screen these companies, choosing only those who are reputable, and whose products, services, or information we feel would be of interest to you. Direct mail is an efficient medium for presenting the latest personal computer goods and services to our subscribers.

Many BYTE subscribers appreciate this controlled use of our mailing list, and look forward to finding information of interest to them in the mail. Used are our subscribers' names and addresses only (no other information we may have is ever given).

While we believe the distribution of this information is of benefit to our subscribers, we firmly respect the wishes of any subscriber who does not want to receive such promotional literature. Should you wish to restrict the use of your name, simply send your request to the following address.

BYTE MAGAZINE
ATTN: SUBSCRIBER SERVICE
P.O. Box 555
HIGHTSTOWN, NJ 08520



Listing 4: BCD floating-point division.

```
{ Divide number in FAC1 by number in FAC2.
{ Leave the result in FAC1.
FDIV:
  IF FAC2_EXP = 0 THEN
    RETURN divide by zero error;
  { If FAC1 = 0, the result is zero.
  IF FAC1_EXP = 0 THEN
    RETURN no error;
  { Calculate the exponent of the quotient.
  FAC1_EXP := FAC1_EXP - FAC2_EXP + BIAS;
  { Determine the sign of the quotient.
  FAC1_SIGN := FAC1_SIGN XOR FAC2_SIGN;
  { Clear FAC3 to hold the result.
  FAC3_MAN := 0;
  REPEAT number_of_digits times
    BEGIN
      DO
        { NOTE: The following expression subtracts BCD numbers.
        FAC1_MAN := FAC1_MAN - FAC2_MAN;
        BORROW := TRUE if borrow is generated
                  else FALSE;
        IF BORROW=FALSE THEN
          Increment lowest nibble in FAC3_MAN;
        WHILE BORROW=FALSE;
        BEGIN
          { Following is a BCD addition.
          FAC1_MAN := FAC1_MAN + FAC2_MAN;
          IF this is not last time through REPEAT loop THEN
            BEGIN
              Shift FAC1_MAN left 1 nibble;
              Shift FAC3_MAN left 1 nibble;
            END
          END
        END
      FAC1_MAN := FAC3_MAN;
      GOTO NORM_FAC1;
```

Listing 5: Pseudocode for converting an integer to a floating-point number.

```
{ Convert integer in IREG to a BCD floating-point number stored in
{ FAC1. NOTE: In this and the floating-to-integer routine, IREG is
{ assumed to hold a 16-bit signed integer.
INT_TO_FLOAT:
  IF IREG < 0 THEN
    FAC1_SIGN := 80H;
  ELSE
    FAC1_SIGN := 0;
  { Clear FAC1 to receive number.
  FAC1_EXP := 0;
  FAC1_MAN := 0;
  { Repeatedly divide IREG by 10. Capture each remainder into top
  { nibble of FAC1_MAN.
  WHILE IREG <> 0 DO
    BEGIN
      IREG := IREG / 10;
      High nibble of FAC1_MAN := remainder from
        previous division;
      Shift FAC1_MAN right 1 nibble;
      FAC1_EXP := FAC1_EXP + 1;
    END
  IF FAC1_EXP <> 0 THEN
    FAC1_EXP := FAC1_EXP + BIAS;
  GOTO NORM_FAC1;
```

Back, by popular demand.

Just a few years ago, illegal hunting and encroaching civilization had all but destroyed the alligator population in the south. They were added to the official list of endangered species in the United States.

Now alligators have made a comeback.

Conservationists intent on preserving this legendary reptile helped the alligator get back on its feet. Once again some southern swamps and marshes are teeming with alligators.

With wise conservation policies, other endangered species have also made comebacks... the cougar, gray whale, Pacific walrus, wood duck, to name a few.

If you want to help save our endangered species, join the National Wildlife Federation, Department 106, 1412 16th Street, NW, Washington, DC 20036.

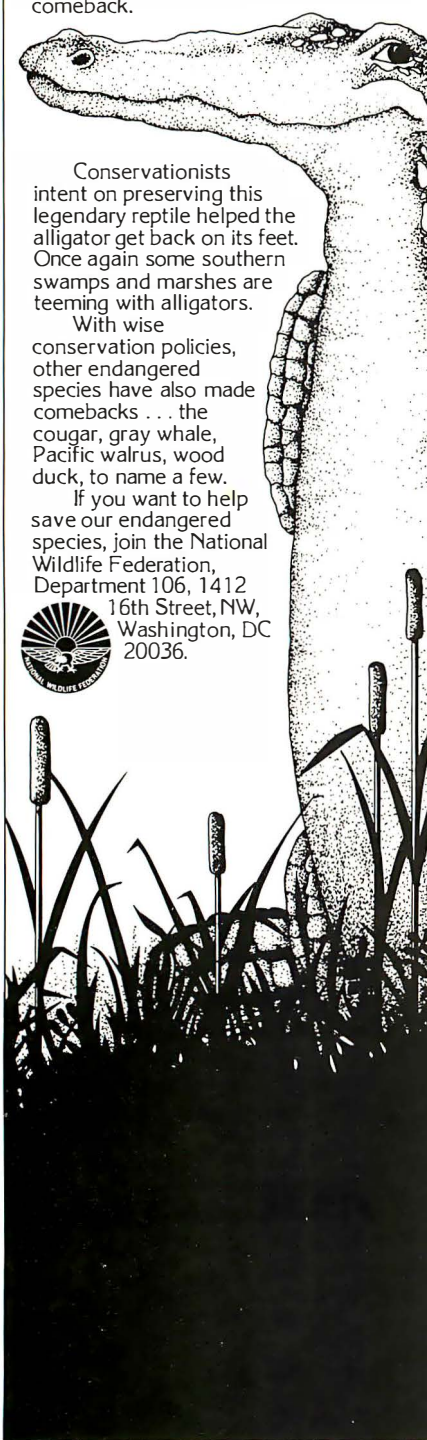

BCDs and CPUs

Most microprocessors in use today include instructions specifically for manipulating binary-coded-decimal numbers. It's a devilish pain doing BCD mathematics if the CPU doesn't have some provision for them.

With the Intel 8088/80286/80386 family, you have to perform a "decimal adjust" on the AL register after an add or subtract operation. So, if I had two BCD numbers, one in AL and the other in BL, and I wanted to add these numbers, I would use the following:

ADD AL,BL
DAA

where DAA is the instruction for "decimal adjust after addition." Similarly, if I were subtracting the numbers, the code would look something like the following:

SUB AL,BL
DAS

You've probably guessed that DAS means "decimal adjust after subtrac-

tion." Notice that the instructions are almost afterthoughts: You tell the processor to perform an addition or subtraction, and it thinks you mean with binary numbers, so you have to tell it "No, they were really BCD numbers, so please go fix the results."

With Motorola's 68xxx family, the situation is a little better. Members of this family have special BCD addition and subtraction operations that don't require an additional cleanup step. To add two BCD numbers, you use the instruction ABCD; the mnemonic stands for "add two BCD bytes and the extend bit." (The extend bit is a kind of auxiliary carry.) As you might suspect, the instruction for subtracting BCD numbers is SBCD.

On both processors, BCD operations occur in byte-wide fashion; the engineers decided, for whatever reason, not to incorporate word-wide or double-word-wide BCD instructions. (On the Intel CPUs, the decimal-adjust instructions affect only the AL register.) This is a big contribution to a BCD package's disappointing speed.

out is given by FAC1_MAN-BIAS.) You can see by examining listing 6 that the function checks for overflow when the accumulator is multiplied by 10 and after each digit is added to the accumulator. If the number is successfully converted, the routine then finishes up by checking the contents of FAC1_SIGN; if the sign is negative, the accumulator is negated.

Optimizations

Right off, I can think of two ways to improve this package's execution speed. The first is in the multiplication routine. Remember that the number of additions performed is dependent on the sum of the digits of the multiplier. This means that if you are multiplying 11 by 99,394, the routine is going to go much faster if 11 is the multiplier (resulting in two additions) rather than 99,394 (resulting in 34 additions). Since it doesn't matter which factor is in which accumulator (by the commutative law), you could easily add a routine that sums the digits of both factors and moves the number with the lowest result into the multiplier's place (FAC1).

In the division algorithm, you might be able to squeeze out some extra perfor-

mance by watching for the case where the dividend is an even multiple of the divisor. This would occur if the subtraction yields a result of zero. If this happens, you could halt all further subtractions and simply continue the shift operations—the subtractions would shift zeros into the quotient anyway. This optimization might not be as effective as the previous one, since a dividend will probably rarely be an even multiple of the divisor.

To BCD or not to BCD

A BCD floating-point package carries some features not found in a similar binary package. In particular, a BCD package is often the mathematics package of choice for business applications, thanks to a BCD number's immunity to conversion between the internal number and what is ultimately displayed or printed. Also, since a BCD floating-point's exponent represents a power of 10, you can represent much bigger (and much smaller) numbers than with a binary floating-point package.

Still, there are trade-offs. As I've shown, the four basic operations execute more slowly using BCD numbers, and it's simpler to make a binary package

continued

**Turn your favorite
C compiler into a
powerful database
manager with the**

C/Database Toolchest



The **C/Database Toolchest™** adds sophisticated file management functions to your Power C™, Turbo C®, QuickC®, or Microsoft® C compiler. With the **C/Database Toolchest™**, your data requires much less disk space than with programs like dBASE®, and you can access your data much faster. Of course the full power of C provides you with an unlimited amount of programming flexibility.

The **C/Database Toolchest™** includes three major components:

- 1) An advanced B+tree library gives you instant access to your data.
- 2) A high-level ISAM library provides you with an easy-to-use C interface, and

3) A complete database manager (with C source code included) shows you how to create impressive applications.

You also receive a comprehensive 350 page manual and a utility for converting dBASE® files.

The **C/Database Toolchest™** supports features that you'd expect to find only in products costing ten times as much. Advanced features include variable length records, variable length keys, multiple keys per index, and multiple indexes stored in a single file. Your data files can contain an unlimited number of records, and each record can be as large as 32K bytes in length.

About the only thing that the **C/Database Toolchest™** doesn't do is cost you a lot of money. We've kept our price low so you can manage your budget as easily as your data.

Now Only \$19.95!

Order now by calling our toll free number or mail the coupon to:

Mix Software
1132 Commerce Drive
Richardson, TX 75081

1-800-333-0330

60 Day Money Back Guarantee

Not Copy Protected ■ Royalty Free

For technical support, please call:
1-214-783-6001



Order Coupon

Name _____
Street _____
City _____
State _____ Zip _____
Telephone _____
Paying By Money Order Check
 Visa MC AX Disc.
Card# _____
Exp. Date _____
Disk Size _____ 5 1/4" _____ 3 1/2"

Qty.	Product	Price	Subtotal
_____	C/Database Toolchest.....	\$19.95	_____
_____	C/Database Library Source..	\$10.00	_____
	B+tree & ISAM library source code		
	Add Shipping (\$5 USA, \$20 Foreign).....		_____
	Texas Residents Add 8% Sales Tax.....		_____
	Total Amount of Your Order.....		_____

B

Listing 6: Converting a floating-point number to its integer equivalent.

```
{ Convert floating-point number in FAC1 to integer in IREG.
FLOAT_TO_INT:
  IREG := 0;      { Prepare the way.
  { See if number has any integer part at all.
  IF FAC1_EXP <= BIAS THEN
    RETURN no error;
  { Can IREG hold the number?
  IF (FAC1_EXP - BIAS) > 5 THEN
    RETURN overflow error;
  REPEAT (FAC1_EXP - BIAS) TIMES
    BEGIN
      IREG := IREG * 10;
      IF result of multiplication has greater
        than 15 bits of precision THEN
        RETURN overflow error;
      Shift FAC1_MAN left 1 nibble;
      N := highmost nibble in FAC1_MAN;
      IREG := IREG + N;
      IF high bit of IREG = 1 THEN
        RETURN overflow error;
    END
  IF FAC1_SIGN = 80H THEN
    Negate IREG;
  RETURN no error;
```

compatible with a floating-point coprocessor. Ultimately, the application will determine which package you use. Since I've provided both BCD and binary packages for your programming toolkits, you should have all you need to choose the right tool for the job.

Next Month

An inside look at something we all have to live with: file directories. ■

Editor's note: The listings printed with this column are pseudocode and are intended to represent the concepts and flow of the actual 80x86 assembly language, which is available in a variety of formats. See page 3 for details.

Rick Grehan is the director of the BYTE Lab. He has a B.S. in physics and applied mathematics and an M.S. in computer science/mathematics from Memphis State University. He can be reached on BIX as "rick_g."

Your questions and comments are welcome. Write to: Editor, BYTE, One Phoenix Mill Lane, Peterborough, NH, 03458.

**Introducing the
Smallest 80386 based
PC Compatible Single
Board Computer
Only 4" x 6"**

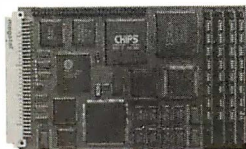

Quark/PC® II

- VGA® Vided/Color LCD Controller
- SCSI Hard Disk Control
- Up to 4 Mbytes Memory and more

To order or enquire call us today.
Megatel Computer Corporation
(416) 745-7214 FAX (416) 745-8792

174 Turbine Drive, Weston, Ontario M9L 2S2

Distributors

- Germany — Tech Team (06074) 98031 FAX (06074) 90248
- Italy & Southern Europe — NCS Italia (0331) 256-524 FAX (0331) 256-018
- U.K. — Densitron (0959) 76331 FAX (0959) 71017
- Australia — Asp Microcomputers (03) 500-0628 FAX (03) 500-9461
- Denmark — Ingeniørfirmaet (02) 440488 FAX (02) 440715
- Finland — Digipoint (3580) 757 1711 FAX (3580) 757 0844
- Norway — AD Elektronikk (09) 877110 FAX (09) 875990
- Sweden — (040) 97 10 90 FAX (040) 13 90 38

Quark is a registered U.S. trademark of F. & K. MFG. Co. Ltd. VGA is a registered trademark of IBM Corp.

megatel

**Protects
while you
type!**



- **Remains In Place** while you use your computer.
- **Avoids Costly Repairs.** Protects delicate electronics from dust, spills, smoke, ashes, staples.
- **Soft, Flexible,** retains normal keyboard feel.
- **Washable, Durable High-Tech Polymer** lasts years.
- **Hundreds of Models.** SafeSkin is available for most PCs, laptops, workstations and clone keyboards.
- **Office • Home • Factory • Classroom • Laboratory**

List Price \$29.95. Please call or write for free color brochure. Dealer inquiries encouraged.

SafeSkin™
Keyboard Protector

Merritt Computer Products, Inc. 14561 S. Westmoreland
Dallas, Texas 75237/(214) 339-0753 • Fax (214) 339-1313
In Canada call 1-800-663-1061

THE BUYER'S MART

A Directory of Products and Services

THE BUYER'S MART is a monthly advertising section which enables readers to easily locate suppliers by product category. As a unique feature, each BUYER'S MART ad includes a Reader Service number to assist interested readers in requesting information from participating advertisers.

RATES: 1x—\$525 3x—\$500 6x—\$475 12x—\$425
Prepayment must accompany each insertion. VISA/MC Accepted.

AD FORMAT: Each ad will be designed and typeset by BYTE. Advertisers must

furnish typewritten copy. Ads can include headline (23 characters maximum), descriptive text (250 characters is recommended, but up to 350 characters can be accommodated), plus company name, address and telephone number. Do not send logos or camera-ready artwork.

DEADLINE: Ad copy is due approximately 2 months prior to issue date. For example: November issue closes on September 8. Send your copy and payment to THE BUYER'S MART, BYTE Magazine, 1 Phoenix Mill Lane, Peterborough, NH 03458. For more information call Brian Higgins at 603-924-3754.

ACCESSORIES

PRO-CLASSIC T-SHIRTS & BUTTONS

JUST SAY NO to expensive, incompatible PCs with a T-shirt or button! T-shirt is \$12.00 plus \$1.50 shipping & handling. Button is \$1.00 plus \$0.50 s&h. State size and quantity when ordering. Send check or money order to:

Advanced Systems Consultants

21115 Devonshire St. #329, Chatsworth, CA 91311

(Sorry, no VISA/MC. CA residents MUST add sales tax. We never cash your check until order is shipped!)

Inquiry 576.

ARTIFICIAL INTELLIGENCE

NanoLISP \$99.99

An MS-DOS Common LISP interpreter that supports most Common LISP operations and strictly adheres to the standard. Numerous advanced and extra features, excellent debugging facilities, sample AI programs, fully-indexed manual, free technical support.

Microcomputer Systems Consultants

P.O. Box 6646, Santa Barbara, CA 93160

(805) 967-2270

BAR CODE

PRINT BAR CODES/BIG TEXT FROM YOUR PROGRAM

Add bar codes and big graphics text to your program. Print from ANY MS-DOS language. Bar codes: UPC, EAN, 2 of 5, MSI, Code 39. Epson, Oki, IBM dot matrix text up to 1/2". LaserJet up to 2". Font cartridges not required. \$179-\$239. 30 day \$\$ back.

Worthington Data Solutions

417-A Ingalls St., Santa Cruz, CA 95060

(800) 345-4220 In CA: (408) 458-9938

CUT RIBBON COSTS!

Re-ink your printer ribbons quickly and easily. Do all cartridge ribbons with just one inker! For crisp, black professional print since 1982. You can choose from 3 models:

Manual E-Zee Inker — \$39.50
Electric E-Zee Inker — \$89.50
Ink Master (Electric) — \$159.00

1000's of satisfied users in 5 years. Money back guarantee.

BORG INDUSTRIES

525 MAIN ST., JANESVILLE, IA 50647

1-800-553-2404 In IOWA 319-987-2976

Inquiry 577.

NEW EXPERT SYSTEM

FirstExpert - A unique expert systems tool that you can master in a few hours! Generates the complete system based on your specification! Built-in learning procedure automatically creates knowledgebase. Interactive structured induction allows you to add new knowledge at any time. Includes consultancy system. Handles up to 10,000 rules on a PCI Demos included! IBM pc's /PS-2's.

An ingenious program. buy now for only \$99.95. s/h add \$500

NovaCast Expert Systems

2530 Berryessa Rd. Suite 607, San Jose, CA 95132

(408) 272-4071 Fax: (408) 437-7777

Inquiry 581.

PORTABLE READER

Battery operated, handheld reader with 64K static RAM, 2x16 LCD display, 32 key keyboard, Real-Time-Clock. Wand or laser scanner. Program prompts and data checking thru its own keyboard. Easy data transfer by RS-232 port or PC, PS/2 keyboard. Direct from USA manufacturer. 30 day \$\$ back.

Worthington Data Solutions

417-A Ingalls St., Santa Cruz, CA 95060

(800) 345-4220 In CA: (408) 458-9938

SELF-INKING PRINTER RIBBON

Awarded United States Patent #4701062

Lasts 10-15 times longer than the conventional ribbon

For printers using 1/2" wide open spool ribbon:

Okidata-82A-83A-84-92-93 Dec LA 180/210
Teletype-33, 35 Dec LA 30/IBM 1443
Star Gemini 10X Teletype-Model 40
Ectel TI 800/810, 820, 880

Contact us by mail, phone or telex, and we will forward you a brochure.

CONTROLLED PRINTOUT DEVICES, INC.

POB 869, Baldwin Rd., Arden, NC 28704

(704) 684-9044 • TELEX: (FILMON-AREN) 577454

Inquiry 578.

Buy your own Book

Get a fully supported LISP program for the MAC without the padded price to pay for an expensive book. \$20 buys it MAC plus or equivalent runs it. Order now and save.

Oosson Software

Box 33113, Coon Rapids, MN 55433

Inquiry 582.

BAR CODE SOLUTIONS

Bar coding is so easy with our complete line of readers. Our PC-Wand readers emulate your PC keyboard or ASCII terminal, and are carried around taking inventory, entering road sales and clocking time. Our bar code label printing software packages work with DOS and most matrix or laser printers. We also sell pre-printed labels. Our hardware can work with nearly every computer in the world.

International Technologies & Systems Corp.

635-C North Berry St., Brea, CA 92621

(714) 990-1880 FAX: 714 990-2503 TLX 6502824734 MCI

Inquiry 583.

BAR CODE

PRINT BAR CODES, BIG TEXT, LOGOS

On EPSON, IBM, Oki dot matrix or LaserJet. Design any format/size on ONE easy screen. 1-120 fields/label. 13 text sizes to 1" — readable at 50 ft. AIG, MIL-STD, 2 of 5, 128, UPC/EAN, Code 39. File input, FAST—\$279. Logos, Product Symbols. Other menu-driven bar code programs from \$49. 30 day \$ back.

Worthington Data Solutions

417-A Ingalls St., Santa Cruz, CA 95060

(800) 345-4220 In CA: (408) 458-9938

BAR CODE MADE EASY

PERCON® E-Z-READER™ keyboard interfaces and multiuser RS-232 models make it easy to add bar code to virtually any computer/terminal WITHOUT SOFTWARE MODIFICATION. Immediate shipping. Two year warranty. Bar code printing software a airtake. Call for details on fast, accurate, easy data entry. Substantial reseller discounts.

PERCON®

2190 W. 11th St., Eugene, OR 97402

1-800-8 PERCON

Inquiry 579.

ARTIFICIAL INTELLIGENCE

NATURAL LANGUAGE C LIBRARY

Increase your market share! Use JAKE to add a natural language front end to your application. JAKE translates English queries and commands into C function calls and data structures. JAKE offers context-sensitive semantic processing; interfaces easily; < 64K mem.

JAKE \$495. INTERACTIVE DEMO \$10

ENGLISH KNOWLEDGE SYSTEMS, INC.

5525 Scotts Valley Dr. #22, Scotts Valley, CA 95066

(408) 438-6922

Inquiry 580.

BAR CODE READERS

For PC, XT, AT, & PS/2, all clones, and any RS-232 terminal. Acts like 2nd keyboard, bar codes read as keyed data. With steel wand—\$399. Works with DOS, Xenix, Novell, Alloy, -ALL software. Lasers, magstripe, & slot badge readers. One year warranty. 30 day \$ back. Direct from USA manufacturer.

Worthington Data Solutions

417-A Ingalls St., Santa Cruz, CA 95060

(800) 345-4220 In CA: (408) 458-9938

PC BAR CODE SPECIALISTS

Bar code readers designed for fast, reliable, cost effective data entry. Looks just like keyboard data! Choose from stainless steel wand or laser interface. Also, powerful Bar Code and Text printing software. Great warranty. Dealer inquiries welcome.

Seagull Scientific Systems

15127 N.E. 24th, Suite 333, Redmond, WA 98052

206-451-8966

THE BUYER'S MART

BAR CODE

BAR CODING SOURCE CODE

UPC, EAN, CODE39, 2 of 5, and Codabar. Ready to run programs with source codes. Toolkit for 'C' programmers. Do barcodes from your own programs. Supports HP LJ and Epson printers. Includes disk, manual, and symbology documentation. No royalties. 30 day money back guarantee.

SymbBCG — \$79.00 Complete

Symbolic

17019 Jeanette Ave., P.O. Box 47496, Cerritos, CA 90703
(CA res. add \$4.81 tax) (213) 926-2823

Inquiry 584.

POSTAL BARCODE PRINTING

P-Bar Plus is the *only* IBM compatible software to use a 9-pin printer to print Postal Barcodes on envelopes. 17 million record capacity with realtime duplicate search. Import/export ASCII text files and records for *free* conversion to ZIP+4. Many more features saves on postage, postal processing and losses from misplaced mail.

T-Lan Systems

RFD 2 Box 1290, Norridgewock, ME 04957
(207) 397-5511

Inquiry 585.

DATA INPUT DEVICES

Bar Code & Magnetic Stripe Readers for microcomputers & terminals, including IBM PS/2 & others, DEC, Macintosh, AT&T, CT, Wyse, Wang. All readers connect on the keyboard cable & are transparent to all software. Low cost bar code print programs, magnetic encoders, & portable readers are also available. GSA contract #G500K87AGSS346.

TPS Electronics

4047 Transport, Palo Alto, CA 94303
415-856-6833 Telex 371-9097 TPS PLA
FAX: 415-856-3843

Inquiry 586.

VARIANT MICROSYSTEMS

BAR CODE READERS DELIVER

WAND/LASER/MAGNETIC CARD CONNECTIVITY
• Keyboard wedges (Internal/External) for IBM PC/XT/AT, PS/2 and portables.

- RS232 wedges for WYSE, Link, Kimtron terminals
- Bar code and label printing software
- Full two year warranty
- **30 Day Money Back Guarantee**
- **Extensive VAR/Dealer Discounts**

3140 De La Cruz Blvd., Suite 200/Santa Clara, CA 95054/(408) 960-1880

Inquiry 587.

CAD/CAM

P-C-B ARTWORK MADE EASY!

Create and Revise Printed-Circuit-Artwork on your IBM or Compatible

- * Help Screens * Dip & Sip Library
- * Printer and Plotter Artwork * Supports Mice
- * Auto-Router available * JCON Menus

Requirements: IBM or Compatible PC, 384K RAM, DOS 3.0 or later. PCBboards: \$99.00 DEMO: \$10.00

PCBoards

2110 14th Ave. South, Birmingham, AL 35205
(205) 933-1122

Inquiry 588.

P-CAD MOUSE

A quality mouse designed to run with the P-CAD software. It requires one RS232C COM Port for the connection. No external security device is needed any more. Complete hardware and documentation for \$575. Call or write for more information. Three years warranty. Checks, CDD, VISA, MC accepted.

UNITEK SYSTEM

9228 Vancouver Drive, Sacramento, CA 95826
(916) 962-6075

P-CAD trademark of Personal CAD System, Inc.

Inquiry 589.

CASE

FINITE STATE PROGRAM COMPILERS

State programs develop quicker, run faster and use less memory than sequential programs. A few keystrokes can replace hundreds of instructions. The Compiler, a CASE software development tool, forms source state programs in: Ada, BASIC, C, FORTRAN and Pascal. FOR IBM DOS.

Price \$200 per lang. (With Primer and Debugger)
Sampler \$50.00 (With all manuals & credit)

AYECO 5025 Nassau Circle, Orlando
INCORPORATED FL 32808 (407) 295-0930

Inquiry 590.

CD-ROM

CD-ROM Drives & Titles

Largest selection for PC & Mac.
Microsoft Programmers Library & Drive \$995
Computer Library \$695 • Public Domain S/W \$99.

Drives from \$699. Hundreds of titles from \$29.
MC/VISA/AMEX, Money-back Guarantee.
Call or write for free 100 page catalog.

Get it all from "The Bureau"

Bureau of Electronic Publishing
121 Norwood Ave., Upper Montclair, NJ 07043
(201) 746-3031

Inquiry 591.

Government Databases on CD-ROMs

Detailed US databases available on 5 CD-ROMs: Economics, Labor, Agriculture, Consumers, and Food. Soon: Health, Business, Tax, Energy and more. Includes software to make tables, DIF or ASCII. \$65 each, MS-DOS req. CD-ROM publishing services available.

Hopkins Technology

421 Hazel Lane, Hopkins, MN 55343
(612) 931-9376 CIS 74017,614

Inquiry 592.

COMMUNICATIONS

Async Executive™ & Tutorial

Interrupt driven transmit & receive. Supports up to eight ports. Buffered I/O to 64K. 50 to 19200BPS. XON/XOFF. DTE/DCE. Modem controls. Transfer characters or blocks. Millisecond timing. Universal language interface. BIOS/DOS extension capabilities. XMODEM w/CRC. 200+ page comprehensive manual. Sample programs include a spooler written in C. For IBM PC/XT/AT & all compatibles. Software Developer's Kit: \$595.

Shipping \$5, Canada \$10, Foreign \$15
CA residents add 6% tax. Checks/MO only.

CIRRUS SOFTWARE, INC.

P.O. Box 51924, Dept. B., Palo Alto, CA 94303
(415) 949-1470

Inquiry 593.

MODEM - 2400

INTERNAL 2400 BAUD, HAYES COMPATIBLE
U.S. MADE FOR PC, XT, AT386

\$69 QTY. ONLY

PC VOICE CARD

MESSAGE CENTER, TELEMARKETER
CLEAR VOICE FOR PCXT, AT 386
ITC CORP. 2630 Walnut Ave., Suite E, Tustin CA 92680
(714) 730-1121 FAX: (714) 730-3837

Inquiry 594.

PC-COMM: A SERIAL DATA COMMUNICATIONS ANALYZER

Displays bidirectional RS-232 data traffic. Logs data to disk monitoring at 19.2K baud. Indicates errors and RS-232 control signals. Runs on all IBM PC/AT/PS2 compatibles. Transfers binary files at 19.2K baud.

PC-COMM \$165 Cable option \$65 S/H \$5

Santa Rosa Software

99 Alden Ave., Rohnert Park, CA 94928
707-664-8440

Inquiry 595.

COMPUTER INSURANCE

INSURES YOUR COMPUTER

SAFWARE provides full replacement of hardware, media and purchased software. As little as \$39 a year provides comprehensive coverage. Blanket coverage; no list of equipment needed. One call does it all. Call 8 am-10 pm ET. (Sat. 9 to 5)

TOLL FREE 1-800-848-3469

(Local 614-262-0559)

SAFWARE, The Insurance Agency Inc.

Inquiry 596.

CROSS ASSEMBLERS

CROSS ASSEMBLERS

Universal Linker, Librarian

Targets for 36 Microprocessors

Hosts: PC/MS DOS, micro VAX, VAX 8000

Developed and supported at:

ENERTEC, INC.

BOX 1312, Lansdale, PA 19446

Tel: 215-362-0966 Fax: 215-362-2404

Inquiry 597.

Professional Series

PseudoCode releases its PseudoSam professional Series of cross assemblers. Most popular processors. Macros, Conditional Assembly, and Include Files. Virtually unlimited size. For IBM PC's, MS-DOS 2.0 or greater. With manual for \$50.00. (MI res. 4% tax). Simulators and disassemblers also available. Shipping \$5, Canada \$10, Foreign \$15. Visa/MC.

KORE Inc.

6910 Patterson, Caledonia, MI 49316 616-791-9333
30 Day satisfaction guaranteed or purchase price refunded.

Inquiry 598.

FANTASTIC SIMULATORS

For the 8048, 8051, 8080, 8085, & Z80 families. Full function simulation including ALL MODES of interrupts. Built-in disassembler. Better than expensive I.C.E.'s.

CROSS ASSEMBLERS

We support the 8048, 8051, 8080/8085, 8096 & Z80 families. Just \$75 each.

Learn Com Company

2440 Kipling St./Ste. 206, Lakewood, CO 80215
303-232-2226

Inquiry 599.

CROSS ASSEMBLERS

Macros, PC Compatible, Relocatable, Conditional, Fast, Reliable from \$150

also: Disassemblers

EPROM Programmer Board

MICROCOMPUTER TOOLS CO.

Phone (800) 443-0779

In CA (415) 825-4200

912 Hastings Dr., Concord, CA 94518

Inquiry 600.

680X0 Cross Assemblers

Now, inexpensive quality 680X0 Cross-Assemblers that use your IBM PC or compatible. All versions support up to 32 char labels, INCLUDE files, PATH names, extensive list output, sorted symbol tables, many common directives, printed manuals. Basic versions create S-records. Linking versions include a Librarian & Linker create either S-records or relocatable modules linked to create S-records or binary files. Minimum requirements are 320K, DOS 2.XX, & 1-1/2" DSD.

Basic 68000/68010—\$49.95 Basic 68020—\$69.95
Linking 68000/68010—\$89.95 Linking 68020/68881—\$129.95
Linking 68030/68881—\$149.95

Checks, VISA, MC accepted. MN residents +6% sales tax.
No PO's or COD's please.

RAVEN Computer Systems

Box 12116, St. Paul, MN 55112 (612) 636-0365

Inquiry 601.

THE BUYER'S MART

CROSS ASSEMBLERS

6800-Family Development Software
Our C Compilers for the 6800, 6801, 6809, & 68HC11 feature a complete implementation (excluding bit fields) of C as described by K&R and yield 30-70% less code than other compilers. Our Assemblers feature macros and conditional assembly. Linker & Terminal Emulator included.

Wintek Corporation
1801 South St., Lafayette, IN 47904
(800) 742-6809 or (317) 742-8428

Inquiry 602.

DATA CONVERSION

MEDIA CONVERSION/DATA TRANSLATION

More than just a straight dump or ASCII transfer!
Word Processing, DBMS, and Spreadsheet data on Disks or Tapes transferred directly into applications running on Mainframes, Minis, Micros, Dedicated Word Processors, Typesetters, and Electronic Publishing systems.
IBM PS/2 & Macintosh supported
#1 in the translation industry!

CompuData Translators, Inc.
3325 Wilshire Blvd., Suite 1202, Los Angeles, CA 90010
(213) 387-4477 1-800-825-8251

Inquiry 603.

DATABASE MGMT SYSTEMS

FREE TRIAL dBASE III CLON!!

"1 on 1" is a programmable relational DBMS... The menu mode is a fancier and more complete version of DBases's assistant mode... 1 on 1 = 3!! is a great deal for those who would be glad to have a dBASE III PLUS clone!"

**** PC MAGAZINE 5/17/88 ****

Free 30 day trial full program U.S.A. only or Buy now get free upgrade. Money back guarantee \$69 + \$5. S/H chkl/Amex. CAN +\$4. Other +\$10. Call or write:

1 on 1 Computer Solutions
26 Finchwood Dr., Trumbull, CT 06611 203-375-0914
dBASE III is a trademark of Ashton-TATE

Inquiry 604.

query dBASE IV data in OS/2

don't waste time waiting for a huge program to load up C>SELECT * FROM DATABASE

- SELECT can read dBASE III+ & IV database & index
- DOS & OS/2 protected mode version, multiuser
- set up query by filling table, no programming
- filter, relation, calc field, graph, histogram, report
- DOS \$38 OS/2 \$38 both \$68 + \$3 S/H check/Visa/MC

YSC Tech (416) 733-0228
47 Protea Gardens, Willowdale, ON M2K 2W5, CANADA
dBASE IV is trademark of Ashton-Tate

Inquiry 605.

DATA/DISK CONVERSION

QUALITY CONVERSIONS

9 Track Tape

2,000 plus Disk Conversions

Optical Scanning

1st Run Computer Services Inc.

1261 Broadway, Suite 508, New York, NY 10001
(212) 779-0800

Inquiry 606.

MAG TAPE & DISK CONVERSIONS
DISK conversion as low as \$10 per MB
TAPE conversion as low as \$15 per MB

Lowest price guaranteed—48 Hour turnaround
Word Processor and Data Base translations
All PC's, Macs, Minis, and Mainframes supported
Mailing lists also available—Visa/MC accepted

A.A. DATA CONVERSIONS

1318 Indian Trail S., Palm Harbor, FL 34683
(813) 786-5245

Inquiry 607.

DATA/DISK CONVERSION

Get the Expertise You Need!

Disk/Disk • Tape/Disk • OCR

Over 1,000 formats! 3 1/2", 5 1/4", or 8 inch disks; 9 track mag tape; 10 MB Bernoulli cartridge. Data base and word processor translation. Specialists in Government Security Data. Call for free consultation.

Computer Conversions, Inc.

9580 Black Min. Rd., Ste J, San Diego, CA 92126
(619) 693-1697

Inquiry 608.

DISK CONVERSIONS

Media transfer too r from: IBM, Xerox, DEC, Wang, Lanier, CPT, Microm, NBI, CT, also WP, WS, MS/WRD, DW4, MM, Samna, DEC DX, MAS 11, Xerox-Writer, ASCII.

FREE TEST CONVERSION

CONVERSION SPECIALISTS

531 Main St., Ste. 835, El Segundo, CA 90245
(213) 545-6551 (213) 322-6319

Inquiry 609.

DISK & TAPE CONVERSIONS AUTOMATICALLY

SAVE TIME AND MONEY

Over 1000 formats from Mini, Micro Mainframe, Word Processors, & Typesetters.

TAPE Conversions as low as \$23.00 MB

DISK Conversions as low as \$15.00 per Disk

Call or write TODAY for a cost saving quotation.

CREATIVE DATA SERVICES

1210 W. Latimer Ave., Campbell, CA 95008

(408) 866-6080

Inquiry 610.

DISK INTERCHANGE SERVICE COMPANY

DISC specializes in transferring files between incompatible disk formats, and between disk and 9-track tape.

- Dedicated Word Processors
- Mini, Micro & Mainframe Computers
- 9-Track Tape (800, 1600 and 6250 BPI)
- MSDOS, CP/M, UNIX, DOS, PRODOS, TSX+, RT:11

2 Park Drive • Westford, MA 01886

(508) 692-0050

Inquiry 611.

THE #1 CHOICE

In disk & tape conversion

for many leading corporations, government agencies, law firms, and companies in every industry—world-wide.

Free test • Satisfaction guaranteed

Call the helpful conversion experts...

Graphics Unlimited Inc.

3000 Second St. North, Minneapolis, MN 55411

(612) 588-7571

Inquiry 612.

IBM PC to HP

FILE COPY

IBM PC to HP File Copy allows IBM PCs, PS/2, compatibles to read, write files written by Hewlett Packard Series 70, 80, 200, 300, 1000, 9000's. We offer custom work using our file copy utilities and program translators. Call for estimate, catalog, data sheet.

Oswego Software

507 North Adams St.
Oswego, Illinois 60543

312/554-3567

Fax 312/554-3573
Telex 858-757

Inquiry 613.

DATA/DISK CONVERSION

CONVERSION SERVICES

Convert any 9 track magnetic tape to or from over 1000 formats including 3 1/2", 5 1/4", 8" disk formats & word processors. Disk to disk conversions also available. Call for more info. Introducing OCR Scanning Services.

Pivar Computing Services, Inc.

165 Arlington Hgts. Rd., Dept. #B
Bullalo Grove, IL 60089 (312) 459-6100

Inquiry 614.

DEMOS/TUTORIALS

LEARN THE ABC'S OF 1-2-3

LEADING EDGE'S New Softvision VCR Training ACCELERATES learning LOTUS 1-2-3. You get 84-min videotape, workbook and practice disk. Now you're up-to-speed on Lotus 1-2-3. Just \$29.95 + 2.50 P&H. ORDER NOW. Money back if not delighted. All major credit cards. CALL NOW.

LIFE DYNAMICS

6050 Peachtree Pkwy., #240-226, Norcross, GA 30091

(800) 548-9608 M-F 10-6

(800) 548-5782 Ext. 12 ANYTIME

Inquiry 615.

INSTANT REPLAY III

Build Demos, Tutorials, Prototypes, Presentations, Music, Timed Keyboard Macros, and Menu Systems. Includes Screen Maker, Keystroke/Time Editor, Program Memorizer, and Animator. Rec'd Great Reviews! Simply the BEST. Not copy protected. No royalties. 60 day satisfaction money back guar. IBM and Compat. \$149.95 U.S. Chk/Cr. Crd. Demo Diskette \$5.00

NOSTRADAMUS, INC.

P.O. Box 9252

Salt Lake City, Utah 84109 (801) 487-9662

Inquiry 616.

DISASSEMBLERS

SOFT-X-PLORE

See "BYTE's May '88 issue pg. 78". Disassemble 500 kb (*) program at 10,000/min. (*) in any file, ROM/RAM memory up to 80386 instruction set (*). **SOFT-X-plore:**

- * is for MS/DOS 2.0+ systems
- * uses 20 algorithms and seven passes (*)
- * only \$99.95 plus S&H w/30 day guarantee.

To order call (800) 446-4656 or info (203) 560-0236

Or write: **RJSWANTEK INC.**

178 Brookside Rd., Newington CT 06111

* best on the market MC/VISA accepted

Inquiry 617.

DISK COMPATIBILITY

IBM PC's USE Mac DISKS

MatchMaker lets you plug any Macintosh external floppy drive into an IBM PC. Half size card and software lets you copy to/from, view directory, initialize, or delete files on the Mac diskette. Works with PCs, XT's, AT's, and compatibles. *The easy way to move information!*

\$149.00 Visa/MC/COD/Chk.

Micro Solutions Computer Products

132 W. Lincoln Hwy., OelKalb, IL 60115 815/756-3411

Inquiry 618.

DISK DRIVES

PS/2 DRIVES FOR PC's AT's

CompatiKit/PC\$279

CompatiKit/AT\$219

Built-in floppy controllers—no problem. Supports multiple drives and formats. Lets your computer use IBM PS/2 1.4M diskettes *plus more!* Call for further information or to place an order. *VISA/MC/COD/CHECK.*

Micro Solutions Computer Products

132 W. Lincoln Hwy., DeKalb, IL 60115 815/756-3411

Inquiry 619.

THE BUYER'S MART

DISK DUPE EQUIPMENT

DO YOUR OWN DUPLICATION

Copy 10,000 or only 10 in as little as 15 seconds each with famous Mountain Duplication equipment at the very best prices! See us for all of your duplication equipment needs from Disks to Drives to Duplicators.

SYSTEMS SUPPORT DATA

214 East Jackson Street, Front Royal, VA 22630
703-635-1787

Inquiry 620.

DISK DUPLICATION

SOFTWARE PRODUCTION

- Disk duplication
- All formats
- EVERLOCK copy protection
- Label/sleeve printing
- Full packaging services
- Warehousing
- Drop shipping
- Fulfillment
- 48-hour delivery
- Consultation & guidance

Star-Byte, Inc.

2880 Bergey Rd., Hatfield, PA 19440
215-997-2470 800-243-1515

Inquiry 621.

DUPLICATION IS THE SINCEREST FORM OF FLATTERY

Let us Flatter you!! See us for all disk duplication needs. 10 disks to 100,000 and more All formats—All systems. Best prices—Our own in-house printing of documentation—labels-sleeves.

SYSTEMS SUPPORT DATA

214 East Jackson Street, Front Royal, VA 22630
703-635-1787

Inquiry 622.

DUPLICATION SERVICES

SOFTWARE DUPLICATION

- One Stop Shopping
- Custom Packaging
- Copy Protection
- Technical Support
- Drop Shipping
- Fast Turnaround
- Competitive Pricing

SATISFACTION GUARANTEED
800-222-0490 NJ 201-462-7628

MEGASoft

P.O. Box 710, Freehold, NJ 07728 See our ads on page 322

Inquiry 623.

EDUCATIONAL VIDEOS

EZ-PC : MS-DOS VIDEO

COMPUTER TRAINING MADE SIMPLE

- Learn MS-DOS Quick & Easy
- No computer jargon—All terms explained
- No prerequisites—Anyone can learn
- Affordable training in your home

ORDER NOW - \$24.95

Add \$2.00 Shipping VISA/MC/AMEX-Check
VIDEOMATION PRODUCTIONS, INC.
8323 Burwood Park Dr., Spring, Texas 77379
713-251-4224

Inquiry 624.

ENTERTAINMENT

NEMESIS™ Go Master®

Go, a game of strategic elegance, has been a way of life in the Orient for over four thousand years. Many consider Go to be the secret of the Japanese businessman's success. "While chess is a game of war, Go is a game of market share" [President of Nikko Hotels].

"If you are interested in Go, buy this program."

Game of the Month J. Pournelle BYTE 7/87

Toyogo, Inc. The Leader in Computer Go.
76 Bedford St. #34-Y, Lexington, MA 02173, (617) 861-0488

Inquiry 625.

FAX COMMUNICATIONS

COMPLETE FAX \$295

Grp. III FAX capability for your PC. Bkgrd. operation, w/pop-up "hot key" for direct faxing from most applications. Scheduled/broadcast transmission, auto redial. Optional 9600 bps, voice mail, more! 2 yr. warranty from The Complete PC. Free 2nd day air shipping.

R. Gile Electronics

358 So. Main St., Ste. #36
Orange, CA 92668

To order, call (800) 527-4453 or (714) 634-3353 24 hr.
For info, poll FAX (714) 634-1644

Inquiry 626.

FLOW CHARTS

FLOW CHARTING II+ HELPS YOU!

Precise flowcharting is fast and simple with Flow Charting II+. Draw, edit and print perfect charts: bold and normal fonts, 26 shapes — 95 sizes; fast entry of arrows, bypasses & connectors; Fast Insert Line; shrink screen displays 200-column chart; 40 column edit screen for detail work, much more!

PATTON & PATTON

81 Great Oaks Blvd., San Jose, CA 95119

1-800-525-0082 Ext. 42 (Outside CA)
408-629-5376 Ext. 42 (CA/Int'l)

Inquiry 627.

STRUCTURED FLOW CHART

NSChart creates Nassi-Shneiderman (structured) flowcharts from a simple PDL. Keywords define structures & text strings appear in the chart. Easy to create, even easier to revise! Automatic chart sizing, text centering. Translators from many languages available. For Mac and IBM PC.

SILTRONIX, INC.

P.O. Box 82544, San Diego, CA 92138

1-800-637-4888

Inquiry 628.

GRAPHICS

35mm SLIDES—In 24 Hours

We transform your PC-Graphics files into full-color high-resolution, 35mm slides and ship within 24 hours. Harvard, Pixie, Lotus, Freelance, and others supported. Files accepted by modem. Free Federal Express on all orders of 20+ slides. Only \$8 per slide. Call for literature or circle reader service number shown below.

Accent Presentations, Inc.

990 Highland Drive, Ste. 202, P.O. Box 1303, Solana Beach, CA 92075
1-800-222-2592

Inquiry 629.

RAINDROP™

FAST, compact PrtScr Utility for end users AND developers. Hardcopy as fast as 10 secs. Average binary size - 6 kbyte. 12 video graphic standards. Scale, rotate, colorize and more. "CALL" from user written programs. Complete 9 & 24 pin dot matrix, inkjet, and laserjet library \$39.95+\$3 s/h.

RAINBOW TECHNOLOGIES

8106 St. David Ct., Springfield, VA 22153

(703) 440-0064

Inquiry 630.

AMAZING GRAPHICS MADE SIMPLE!

Announcing AXUM, the first truly sophisticated technical graphics and analysis program for PCs.

- analyze/explore/publish
- ultra-high resolution
- data windows/menus/help
- extremely easy to use
- display/edit
- color/2D & 3D
- interactive
- powerful

TriMetrix, Inc.

444 NE Ravenna Blvd., Suite 210-BY, Seattle, WA 98115
(800) 548-5653 ext. 062 (206) 527-1801 in WA

Inquiry 631.

GRAPHICS LIBRARIES

GRAPHICS LIBRARIES

Very Fast 2D/3D Autoscaling Graphics for Microsoft Languages. 3D Lines Use Color. Fast Polygon Fill, Solid/Wireframe. Color/Blinking Text. XY, Bar, Smith Contour & 3D Fishnet Graphs. Supports CGA/EGA/VGA/Herc & Dot Matrix/Laser/Plotters @ Full Resolution. Print Screen. Port. \$140 NO ROYALTIES. FORTRAN Source + \$30.

CHIRP TECHNICAL SERVICES

P.O. Box 551, Del Mar, CA 92014-0551
(619) 632-9510

Inquiry 631.

HARD DRIVE REPAIR

HARD DRIVE REPAIR

WE WILL REPAIR YOUR HARD DRIVE AT A FRACTION OF THE COST OF REPLACING IT. FAST TURNAROUND!!! CALL FOR DETAILS

H & W micro, inc.

528-C FOREST PARKWAY
FOREST PARK, GA 30050

(404) 366-1600

Inquiry 632.

HARDWARE

CHIP CHECKER

- 74/54 TTL + CMOS
 - 144000 CMOS
 - 14-24 Pin Chips
 - 8000 Nat. + Signetics
 - 9000 TTL
 - .3" + .6" IC widths
- Tests/Identifies over 650 digital chips with ANY type of output in seconds. Also tests popular RAM chips. IBM compatible version \$259. C128 + C64 version \$159.

DUNE SYSTEMS

2603 Willa Dr., St. Joseph, MI 49085

(616) 983-2352

Inquiry 633.

Rack-Mounted AT 286 or 386

Industrial, Med-Tech, Laboratory and Comm. needs
◊ Intel 80286 or 80386 CPU daughter card ◊ Passive back plane (8-10 expansion slots) ◊ Fits standard 19" rack ◊ Heavy-duty dual fans ◊ Clean air filter ◊ High-speed, high-quality hard disk available ◊ Slide-mounted CPU chassis for easy maintenance access ◊ Power supply up to 360 Watts. For details and prices, Contact:

(516) 589-8666

International

Telecommunications Services

Inquiry 634.

LATEST AWARD BIOS

PC/XT * 286 * 386

Support For:

- Enhanced Keyboards
- EGA & VGA Graphics
- 3.5" Floppies & More. . .

Authorized AWARD Distributor

1-800-423-3400 or (412) 782-0384

KOMPUTERWERK, INC.

851 Parkview Blvd., Pittsburgh, PA 15215

Inquiry 635.

Wholesale PC Parts

- 286 6/12mhz AT Baby Motherboard. . . . \$199
 - 1.2 High Density Floppy. \$71
 - 1200b Modem, Internal. \$49
 - IBM Compatible Mouse, Serial. \$34
- Authorized Mark V distributor of IBM Compatibles
Prices starting at \$299

Micro N.W. Distributors

22043 68th Ave. South, Kent, WA 98032
Call: 206-859-9210

Inquiry 636.

THE BUYER'S MART

HARDWARE

Apple • Service Parts
• Accessories • Systems •
BUY ★ SELL ★ TRADE
PRE-OWNED Electronics, Inc.
 30 Clematis Avenue, Waltham, MA 02154
800-274-5343 FAX 617-891-3556
 Service Centers and Dealers welcome

Inquiry 637.

HARDWARE/ADD-ONS

The World's First Highest Density Module!
 * 16 Meg on the smallest surface
 * Organization: 2x1024Kx9 bit
 * Package: DIL 64 pin Jedec-Standard
 * Technology: CMOS, hybrid, 18xHMS1100JP-10
 * Compatibility: With two Hitachi HB56A 19-10
 * Suitable for extension of basic memory
For more information please write or call:
TermoTrol Corp.
 1888 Century Park East, Suite 1900, L.A. CA 90067
 Tel. 213 284-3242

Inquiry 638.

HARDWARE/COPROCESSOR

DIGITAL SIGNAL PROCESSOR
 DSP products for the IBM PC/XT/AT based on the TI TMS32010 and TMS320C25. Designed for applications in communications, instrumentation, speech, and numeric processing. Offered with 12 bit 110 KHz A/D and D/A and continuous to disk data acquisition & playback option. \$650 and up.
DALANCO SPRY
 89 Westland Ave., Rochester, NY 14618
 (716) 473-3610

Inquiry 639.

SC/FOX™ PARALLEL COPROCESSOR
 PC/XT/AT/386 plug-in board with Fort software. 10 MIPS operation, up to 50 MIPS burst. 64K to 1M byte memory. Uses Harris RTX 2000™ RISC realtime CPU with 1-cycle multiply, 1-cycle 14-priority interrupts, two 256-word stacks, three 16-bit timer/counters, 16-bit i/o bus. Ideal for real-time control, signal and image processing and multiple board operation. From \$1,995.
SILICON COMPOSERS, INC. (415) 322-8763
 210 California Ave., Suite K, Palo Alto, CA 94306

Inquiry 640.

TMS32010 DSP

COMPLETE DEVELOPMENT SYSTEM for the TMS32010 Digital Signal Processor including a MC68000 host processor, power supply, serial interface with software, 32010 and 68000 cross-assemblers (hosted on a PC), documentation, schematic, operating system, cables. Special Price — \$735.00.
Phone URDA, Inc.
1-800-338-0517

Inquiry 641.

IBM SOFTWARE

IBM* SOFTWARE NEW VERSION
SAVE UP TO 65%, Quantity Limited
 *First come, First served, VISA/MC/check
 COBOL V2.0 \$295 Prof. FORTRAN V1.3 \$250
 C compiler \$195 Macro assembler V2.0 \$75
 BASIC Compiler V2.0 \$95 BASIC Ref. V3.2 \$25
 LAN Program V1.2 \$75 Plotting Place \$150
The Computer Place, Inc.
 301-330-6016 Fax 301-926-3415
 *IBM is trademark of International Business Machine.

Inquiry 642.

INTEGRATED CIRCUITS TTL

7400 TTL Series

Part	Per 100	Per 1000	Part	Per 100	Per 1000
7400	.13 ea	.09 ea	7420	.13 ea	.09 ea
7410	.13	.09	7430	.13	.09
74123	.27	.18	7474	.19	.14
74151	.33	.22	7486	.23	.16
74153	.33	.22			

NEW SENSOR CORPORATION
 Suite 526, 245 E. 63rd St., NYC, NY 10021
Add \$3.00 for shipping 212 980-6748

Inquiry 643.

INTERFACES

PC/XT/AT COMPATIBLE KEYBOARD CONTROLLERS
 Controls custom membrane or mechanical switch matrices of up to 512 keys. Connects to a standard PC/XT/AT keyboard port and sends standard or user-defined Bios Scan codes to your PC. An extra port on the USAR controller board allows you to use both a custom keyboard and a standard (83/84 or 101/102) keyboard simultaneously. No special software or device drivers required. The USAR controller board is powered by the PC. Low one time programming charge if customized key codes required. Large volume or limited runs. For further information call or write:
USAR CONSULTANTS, INC.
 2160 North Central Road, Fort Lee, NJ 07024
 Phone: (201) 947-6329 FAX: (201) 947-2264

Inquiry 644.

INVENTORY MANAGEMENT

STOCK-MASTER 4.0
 Commercial grade inventory management software at micro prices.
 • Supports all 12 transaction types
 • Trend Analysis
 • Quality Control
 • Multiple Locations
 • Purchase Order Tracking
 • Open Order Reporting
 • Serial/Lot # Tracking
 • Stock Status Reporting
 • Activity History Analysis
 • Bill of Materials
 • Purchase Order Writing
 • Order Entry
 • Material Requirements
 • On Line Inquiry
Applied Micro Business Systems, Inc.
 177-F Riverside Ave., Newport Beach, CA 9 563 714-759-0582

Inquiry 645.

dFELLER Inventory
 Business inventory programs written in modifiable dBASE source code.
 dFELLER Inventory \$150.00
 Requires dBASE II or III, PC-DOS/CPM
 dFELLER Plus \$200.00
 with History and Purchase Orders
 Requires dBASE III or dBASE III Plus (For Stockrooms)
Feller Associates
 550 CR PPA, Route 3, Ishpeming, MI 49849
 (906) 486-6024

Inquiry 646.

INVESTMENT SOFTWARE

OPTIONS 1-2-3
 OPTIONS 1-2-3 Pro Series is a Lotus Add-in utility that allows the user to calculate option prices, volatilities and sensitivities directly within the spreadsheet and to create customized templates. A choice of three pricing models is available for Real-Time or offline analysis.
 Ask about our fixed income, 3D graph and economic analysis software!
Montgomery Investment Group
 332 Pine Street, Suite 514, San Francisco, CA 94104
 415-986-6991

Inquiry 647.

LAPTOP COMPUTERS

LAPTOP SPECIALS

TOSHIBA • Zenith • NEC • SHARP LAPTOPS
 • Hard drives for Tandy 1400 LT & Toshiba 1100+
 • AFFORDABLE 5¼" or 3½" DRIVE UNITS for LAPTOPS & DESKTOPS • DICONIX PRINTERS • 788 card for T1000 • 2400 BAUD MODEMS for Laptops • Fast reliable and friendly service. For Low Pricing call
World wide sales
COMPUTER OPTIONS UNLIMITED
 201-469-7678 (7 Days, 9am-10pm Eastern time)

Inquiry 648.

LAPTOP COMPUTERS

Laptop Connection
2PC — THE File Transfer Utility
 • Lap to Lap, Lap to Desk • Desk to Desk, PC to PC
 • Super Easy to Use • No Installation Required
 • Breaks the "Bridge-Link" Price Barrier • 115 K Baud
\$55 w/universal cable, \$45 w/o cable
See Jan. 89 Issue—"What's New" Column—p.94
PLUS... Quality Cables at FAIR Prices:
 • Null Modem (6') \$12 • Printer (6') \$10
 • Kbd Ext (6') \$12 • Mon Ext (6') \$12
 • Par Print (6') \$10 • Serial (6') \$10
 MANY MORE CABLES AVAILABLE. Mac & PC
Thompson Computing—587 N. Ventu Park Rd., Ste. 306,
Newbury Park, CA 91320, (805) 498-7533 (VISA MC)

Inquiry 649.

LAPTOP PERIPHERALS

LAPTOP BACKLIGHTS

Factory Installed • 90 Day Warranty
 Toshiba, Amstrad, Sanyo, DG,
 Kaypro, IBM, HP, etc. **\$295**
The Portable Peripherals People
Axonix Corporation
(801) 466-9797

Inquiry 650.

MEMORY CHIPS

MEMORY CHIPS
 41258-15-12-10 Call 51000 (1 Meg) Call
 4164-15 Call 51258 for Compaq 386. Call
 4164-12 Call 8067-3-2 Call
 41128 Piggy Back for AT Call 80287-6-8-10 Call
 41464-12 (64Kx4) Call 80387 Call
 414256 (256Kx4) Call NECV-20-8 Call
 2764,27128,27256,27512 Call Mouse Call
Prices subject to change
ESSKAY 718-353-3353

Inquiry 651.

D-RAMS

NEW AND PULLS AT LOW COST
WE ALSO SELL SIPPS, ZIPS,
SIMS AND OTHER MODULES.
SPECIAL 256-15P \$7.95
ITC CORP. 2630 Walnut Ave., Suite E, Tustin CA 92680
(714) 730-1121 FAX: (714) 730-3837

Inquiry 652.

MONITOR INTERFACE

DRIVE MULTIPLE MONITORS
 with one PC using our VOPEX video port expanders. Featuring no loss of resolution or color, presentations are more dramatic. We have a VOPEX for PC, PS/2, MAC II & workstations. Units are available from 2 to 10 output ports.
NETWORK TECHNOLOGIES INC.
600-RGB-TECH or 218-543-1646 MC/VISA/AMEX
 19145 Elizabeth St., Aurora, OH 44202

Inquiry 653.

NETWORKING

SPS - 3COM PRINT SERVER

Share any printer connected to any 3Com's 3Plus Network workstation by all network users. SPS breaks down 3Plus's requirement that all network printers be attached to the File Server, allowing users to print from any network workstation. Nevertheless, it still works with all the existing 3Plus's print commands:
 1) Use only 2Kbytes of the workstation memory and support all 3Com's print commands and all MS-DOS, BIOS and applications printing activities.
 2) Use the original 3Com "3p" commands as link, unlink etc...
 3) The print server can run on any workstation using less than 30Kbytes.
Shany Computers Ltd.
 4 Smilansky st., Rector building, Natanya, Israel 42432
 Telephone (972) (53) 333931 Fax: (972) (53) 342418

Inquiry 654.

THE BUYER'S MART

NETWORKING

MP STARTUP

MP STARTUP—Software toolbox enabling "master" to submit a process to any available or dedicated network station "slave" for remote execution. Remote execution can be synchronized and controlled by master using named pipe—the standard communication protocol. Named pipe interface is simple and easy to use as the MS-DOS file system interface and include functions as "pipe read" and "pipe write" similar to "file open", "file read", "file write" etc.

Shany Computers Ltd.

4 Smlansky st., Recter building, Natanya, Israel 42432
Telephone (972) (53) 333931 Fax: (972) (53) 342418

Inquiry 655.

OBJECT ORIENTED TOOLS

OBJECT ORIENTED TOOLKIT

TRIPLE your productivity with Complete C™
The only C object oriented development utility with precompiler, foundation classes (source code included), make, integrated debugger, documentation generator, profiler, streamliner, and full technical support.

Introductory Price: \$269

Complete Computer Corporation

111 West 57th St., NY, NY 10019
212-582-2635

Inquiry 656.

PROGRAMMERS TOOLS

Menu Creator™ \$99.95

A program generator for menu-driven user interface. Edit menu windows interactively using WYSIWYG screen editor—Menu Creator™ generates a linkable menu object file. Excellent for complex menu systems. Capable of handling command trees with hundreds of menu items. Mouse support and context-sensitive help. FORTRAN, PASCAL, C, BASIC supported.

Call your dealer

For free utility software contact: **Avanpro Corp.**
P.O. Box 969, Pacific Palisades, CA 90272
(213) 454-3866

Inquiry 657.

TLIB™ 4.1 Version Control

"TLIB" is a great system" — *PC Tech Journal 3/88*. Full-featured configuration mgmt for software professionals. All versions of your code instantly available. Very compact, only changes are stored. Check-in/out looks, revision merge, branching, more. Mainframe deltas for Pansophic, ADR, IBM, Unlays, MS-DOS. \$99.95, or 5-station LAN \$299.95 + shipping

BURTON SYSTEMS SOFTWARE

P.O. Box 4156, Cary, NC 27519 (919) 856-0475

Inquiry 658.

"C" WINDOWING \$49.95

MS-DOS virtual screen library. Unlimited text windows. 100+ functions/macros. Move, resize, hide, pop-up, edit, etc. Attributes, tabs, scroll/alignment bars. K&R print, raw/processed I/O, cursor mgmt. Easy to use. Excellent doc. NJ add 6%. \$3.00 S&H. 15 day \$ back. Check or money order. Specify compiler (Microsoft, Lattice, Turbo). Allow 2-4 wks. Write:

Commonwealth Data Systems, Inc.
P.O. Box 568, Lincroft, NJ 07738

Inquiry 659.

DEVELOPMENT TOOLS

Professional Programmers Extender: Standard Mac interface, lists, printing, graphics, tiling. Extender GraphPac: Quality color graphs. Line, bar, semi-log, customizable symbols.

INVENTION Software
(313) 996-8108

Inquiry 660.

PROGRAMMERS TOOLS

CREATIVE INTERFACE TOOLS for Borland Language Users

Create graphic mouse cursors, symbols, bit-mapped character sets, and dynamic, self-calculating menus in text or graphics. Control program flow with keyboard or mouse. Supports Turbo C, Turbo Pascal, Turbo Prolog and Turbo Basic. Three features, one price.

\$69.95

1-800-622-8366

Maxx Data Systems, Inc.

1126 S. Cedar Ridge, Suite 115, Duncanville, TX 75137

Inquiry 661.

TURBO PLUS \$149.95

Programming tools for Turbo Pascal 5.0 Screen Painter, Code Generator, I/O Fields, Dynamic Menus, Programming Unit Libraries, Sample Programs, 280 Page Illustrated Manual. 60 Day Satisfaction Guarantee Brochures & Demo Diskettes avail. Highly Favorable Reviews! IBM & Compatibles.

Nostradamus Inc.

P.O. Box 9252, Salt Lake City, UT 84109
(801) 487-9662

Inquiry 662.

Get INSIDE!

The best PC software performance tool is now better than ever with source line timing, caller timing and arbitrary event timing—all with microsecond accuracy and without source modification. The expanded DOS analysis mode identifies I/O bottlenecks. \$125

Call today for a free brochure and the latest list of supported compilers. 30-day guarantee. VISAM/CCOD

Paradigm Systems

P.O. Box 152, Milford, MA 01757
(800) 537-5043 In MA: (508) 478-0499

Inquiry 663.

Modula-2

Graphix is the M2 interface to the widely used MetaWindow professional graphics library. Supports multiple fonts, mouse tracking, many printers (incl. PostScript & LaserJet), over 30 display adapters, and hundreds of modes. For JPI TopSpeed, LogiTech, StonyBrook, and other compilers. From the creators of Repertoire (\$149), Macro2 (\$89), EmsStorage (\$89), DynaMatrix (\$69), ModBase (\$39), etc. *MC/VISA/AMEX/CCOD.*

PMI

4536 SE 50th, Portland, OR 97206
(503) 777-8844; FAX: (503) 777-0934

Inquiry 663.

FREE BUYER'S GUIDE

Programmer's Connection is an independent dealer representing more than 300 manufacturers with over 800 software products for IBM personal computers and compatibles. We have serviced the professional programmer since 1984 by offering sound advice and low prices. Call or write today to receive your FREE comprehensive Buyer's Guide.

Programmer's Connection US 800-336-1166
7249 Whipple Ave. NW Canada 800-225-1166
North Canton, OH 44720 International 216-494-3781

Inquiry 664.

'C' DOCUMENTATION TOOLS

- C-CALL \$39 Creates graphic tree of caller/called structures, and files-vs-procedure table-of-contents
- C-HDR \$39 Creates/inserts/updates headers for each procedure showing caller/called and identifiers
- C-LIST \$29 List, action-diagram, reformat programs
- C-REF \$29 Local/global/parameter cross reference
- SPECIAL \$99 All 4 plus integrated C-COD version

SOFTWARE BLACKSMITHS INC.

6064 St. Ives Way, Mississauga, ONT Canada L5N-4M1
(416) 858-4466

Inquiry 665.

PUBLIC DOMAIN

\$3.00 SOFTWARE FOR IBM PC

Hundreds to choose from, wordprocessors, databases, spreadsheets, games, lotto, communications, business, music, bible, art, education, language and useful utilities for making your computer easier to learn. Most programs have documentation on the disk.

Free 125 page catalog.

BEST BITS & BYTES

P.O. Box 8245, Dept-B, Van Nuys, CA 91409

In CA: (818) 764-9503 800-245-BYTE

Inquiry 666.

75¢ per DISK SALE

20 TOP IBM PC PD/SW DISKS (360K)

ONLY \$15 + \$3 S&H

QubeCalc, EDRAW, AutoMenu, Math Tutor, PC-DOS Help, Baker's Dozen, Languages, EZ-Form, PC-Style, PackDisk, PC-Stock, KidGames, Best Games, Home Inventory, PC-Outline, Form Letters, ImagePrint, SideWriter, PC-Prompt, Best Utilities.

BRIGHT FUTURES INCORPORATED

P.O. Box 1030, East Windsor, CT 06088
FREE CATALOG (\$1 per disk)

Inquiry 667.

FREE SOFTWARE BEST OF PUBLIC DOMAIN & SHAREWARE.

Carefully selected and edited programs for I.B.M. Send S.A.S.E. for free catalog.

C.C.S., Inc. Dept. B1

P.O. Box 312, Lafayette Hill, PA 19444

Inquiry 668.

FREE CATALOG PUBLIC DOMAIN/SHAREWARE

• 400 IBM PC & compatibles disks • 200 Amiga disks • 125 Atari ST disks

PC disks as low as \$1.25 each, Amiga & ST as low as \$1.60 each! Rent or buy. Free shipping! Call toll free, write or circle reader service for FREE BIG CATALOG with full descriptions. Please specify computer—48 hr. turnaround!

Computer Solutions

P.O. Box 354—Dept. B, Mason, Michigan 48854
1-800-874-9375 (M-F 10-6 EST) 1-517-628-2943

Inquiry 669.

- CLIP ART
- GRAPHICS
- LASER FONTS
- CAD
- ELECTRONICS
- GAMES
- TRAVEL
- AUDIO/VIDEO
- SECURITY
- EDUCATION

For **FREE CATALOG** write to:
CWI Information Services

P.O. BOX 4851, Anaheim, CA 92803

Or telephone (714) 879-7917 24 HOURS!

Inquiry 670.

RENT SOFTWARE \$1/DISK

Rent Public Domain and User Supported Software for \$1 per diskfull or we'll copy. IBM (3 1/2" also), Apple, C-64, Sanyo 550 and Mac. Sampler \$3. VISA/MC. 24 hr. info/order line. (619) 941-3244 or send #10 SASE (specify computer) Money Back Guarantee!

FutureSystems

Box 3040 (T), Vista, CA 92083

office: 10-6 PST Mon-Sat. (619) 941-9761

Inquiry 671.

THE BUYER'S MART

PUBLIC DOMAIN

FREE IBM SOFTWARE

FREE CATALOG also contains SHAREWARE, 5 1/4 and 3 1/2-inch. All categories. ENGINEERING, CAD, DESKTOP PUBLISHING, LANGUAGES, UTILITIES, BUSINESS, GRAPHICS, SPREADSHEETS, WORD PROCESSORS, CHURCH, MEDICAL, HEALTH, EDUCATION, HOME.

SECTOR SYSTEMS COMPANY, INC.
Dept. B-4, 416 Ocean Avenue, Marblehead, MA 01945
(617) 639-2625

Inquiry 672.

FREE CATALOG

\$1 IBM SOFTWARE

For your free 32 page Master Edition catalog featuring the best of IBM Shareware from just \$1 each, call or write today!

1-800-338-2118

SOFSOURCE
Box 828, East Lansing, MI 48826

Inquiry 673.

FREE SOFTWARE CATALOG

Low as \$1.20/disk
Over 1000 quality IBM software
On 5.25" and 3.5" format
From outside U.S.A., except Canada,
please send US \$2.00 refundable with order.
For fast service, write to

SOFTSHOPPE
P.O. BOX 7 9, Ann Arbor, MI 48105
(313) 763-8721

Inquiry 674.

FREE SOFTWARE

We send you 15-20 new IBM programs a month on 5 disks—FREE! You pay only \$5. shipping/handling. Annual membership reg. \$29.95. Join today for only \$9.95 and we'll send you over 30 programs on 10 disks as a bonus—FREE! No gimmicks—no catches!

toll free 800 669-2669 ext 348

SOFTWARE of the MONTH CLUB
we take visa/mastercard/amex

Inquiry 675.

SECURITY

THE ULTIMATE COPY PROTECTION

- Completely Menu Driven
- Defeats all Hardware/Software Copiers
- No Source Code Changes
- Multiple Layering
- No Damaged Media
- Full Hard Disk Support
- Unlimited Metering
- FREE Demo Disk

*Quite
Simply
The Best
Way To
Protect
Your Valuable
Software Investment*

STOPCOPY™ \$325⁰⁰ STOPCOPY PLUS™ \$450⁰⁰
BBJ COMPUTER SYSTEMS® (301) 871-1094
14105 Heritage La., Silver Spring, MD 20906 FAX: (301) 460-7545

Inquiry 676.

BIT-LOCK® SECURITY

Piracy SURVIVAL 5 YEARS proves effectiveness of powerful multilayered security. Rapid decryption algorithms. Reliable/small port transparent security device. PARALLEL or SERIAL port. Complemented by economical KEY-LOCK™ and multifeatured COMPU-LOCK™ including countdown, timeout, data encryption, and multiproduct protection.

MICROCOMPUTER APPLICATIONS
3167 E. Otero Circle, Littleton, CO 80122
(303) 922-6410/770-1863

Inquiry 677.

SECURITY

ELECTRONIC SHREDDER NOW AVAILABLE TO PUBLIC

Absolute security. Program totally erases sensitive files while leaving all other files intact. Eliminates deleted files on any size hard or floppy drive. Data CANNOT be re-created by ANY utility. IBM or Compatibles. Perfect for legal, financial, military applications. \$89. VISA/MC

ProWest Inc.

4313 Lomas Blvd. NE, Albuquerque, NM 87110
1-800-825-8375

Inquiry 678.

COPY PROTECTION

The world's leading software manufacturers depend on Softguard copy protection systems. Your FREE DISKETTE introduces you to SuperLock™—invisible copy protection for IBM-PC (and compatibles) and Macintosh.

- Hard disk support
- Customized versions
- No source code changes
- LAN support
- New upgrades available

(408) 773-9680

SOFTGUARD SYSTEMS, INC.

710 Lakeway, Suite 200, Sunnyvale, CA 94085
FAX (408) 773-1405

Inquiry 679.

SOFTWARE/ACCOUNTING

dBASE BUSINESS TOOLS

- GENERAL LEDGER
- ORDER ENTRY
- JOB COSTING
- BILL OF MATLS
- PAYROLL
- PURCH ORD/INVENTORY
- ACCOUNTS RECEIVABLE
- JOB ESTIMATING
- SALES ANALYSIS
- ACCOUNTS PAYABLE

\$99 ea. + S&H

DATAMAR SYSTEMS Cred. Card-Check-COD
4876-B Santa Monica Ave.
San Diego, CA 92107 (619) 223-3344

Inquiry 680.

SOFTWARE/BASIC

Save time, money, & brain cells!

QuickWindows Advanced user-interface library supports windows, menus, dialog boxes, help, mouse, and more. For text and graphics modes thru VGA. Fast and intuitive! QuickComm communications library supports up to 16 comm. ports. Hayes modems, xmodem and ymodem file transfer, and more. All interrupt driven. Easy to use!

Each library written in assembly and comes with complete manual. \$139 each. For Microsoft QuickBasic or BASCOM.

Software Interphase, Inc.

5 Bradley Street, Suite 106, Providence, RI 02908
(401) 274-5465 Call now for FREE terminal/demo program.
Fax # 401-272-1273

Inquiry 681.

SOFTWARE/BUSINESS

DATA ENTRY SYSTEM

Heads-down data entry with two-pass verification for the IBM PS/2-PC/XT/AT & compatibles. Features include: Auto dup/skip, verify bypass, range checks, table lookups, a complete edit language. Fully menu driven. Price \$395

Call for our free 30 day trial period.

COMPUTER KEYES

21929 Makah Rd., Woodway, WA 98020
Tel: 206/776-6443 USA: 800/356-0203 Fax: 206/776-7210

Inquiry 682.

TSAB88—TRANSPORTATION PROGRAMMING

A general-purpose system for solving transportation, assignment and transshipment problems (capacitated or uncapacitated) with up to 1300 origins and destinations. Build TSAB88 into your own programs with compiled Turbo Pascal units. TSAB88 reads/writes LOTUS worksheets. Use 1-2-Symphony as a matrix generator or post processor. Many other features including interactive and batch operation, spreadsheet display and editing, problem/basis storage, file I/O, Simplex restart, report generator, sensitivity analysis. \$149 with manual and 8087 support. \$299 with Turbo Pascal units.

Eastern Software Products, Inc.

P.O. Box 15328, Alexandria, VA 22309
(703) 360-7600

Inquiry 682.

SOFTWARE/BUSINESS

LOW COST/HIGH QUALITY

Established, Powerful, Complete, Business Management Software Systems. Point-of-Sale/Inventory Control "SALES-PRO", Service and Repair, Video/Rental Store Management, Church Management, Accounting and Many more starting at \$39. For IBM PC Compatibles and the Atari ST.

HI-TECH ADVISERS

P.O. BOX 7524, Winter Haven, FL 33883-7524
1-800-882-4310 Florida (813) 294-1885

Inquiry 683.

SOFTWARE/ENGINEERING

DATA ACQUISITION ON MS-DOS AT-VME

Our compiler ALLCON can handle software for processes up to 100 PLC reg and 100 PLC functions and 500 I/O in a real-time kernel. The system can be: A control, alarm, regulating and measuring system with timechannels, peak, status, and supervision functions. Introduction price: The first 100 orders ALLCON software and one Multif. card with 16 AI (12 bit), 1 AO, 16 DI and 16 D/O with daughterboards. \$995.—for each CPU license

10 years
exp. of
computer

ALLregulator AB

415 09 Göteborg Sweden

Fax 46 31434730 tel 46 31480180 agents wanted

Inquiry 684.

PRACTICAL ENGINEERING TOOLS

Hobbyists — Students — Engineers
CIRCUIT DESIGN — LOGIC SIMULATION
FFT ANALYSIS — CIRCUIT ANALYSIS
MATHEMATICS — PC/MSDOS
VISA/MC

ALL UNDER \$50 — FREE CATALOG
BSOFT Software (614) 491-0832
444 Colton Rd., Columbus, OH 43207

Inquiry 685.

Affordable Engineering Software

FREE APPLICATION GUIDE & CATALOG
Circuit Analysis • Root Locus • Thermal Analysis • Plotter Drivers • Engineering Graphics • Signal Processing
• Active/Passive Filter Design • Transfer Function/FFT Analysis • Logic Simulation • Microstrip Design • PC/MSDOS • Macintosh • VISA/MC

BV Engineering Professional Software
2023 Chicago Ave., Suite B-13, Riverside, CA 92507
(714) 781-0252

Inquiry 686.

SIMULATION WITH GPSS/PC™

GPSS/PC™ is an IBM personal computer implementation of the popular mainframe simulation language GPSS. Graphics, animation and an extremely interactive environment allow a totally new view of your simulations. Simulate complex real-world systems with the most interactive and visual yet economical simulation software.

MINUTEMAN Software

P.O. Box 1717, Stow, Massachusetts, U.S.A.
(508) 897-5662 ext. 540 (800) 223-1430 ext. 540

Inquiry 687.

Circuit Analysis — SPICE

Non-linear DC & Transient; Linear AC.
* Version 3B1 with BSIM, GaAs, JFET, MOSFET, BJT, diode, etc. models, screen graphics, improved speed and convergence.
* PC Version 2G6 available at \$95.
Call, write, or check inquiry # for more info.

Northern Valley Software

28327 Rothrock Dr., Rancho Palos Verdes, CA 90274
(213) 541-3677

Inquiry 688.

THE BUYER'S MART

SOFTWARE/ENGINEERING

ELECTRONIC TEMPLATES SCHEMATIC SYMBOLS

In Macintosh MacPaint format.
Hundreds of symbols including: common components, TTL, CMOS, linear & more.
Copy & Paste in seconds.

\$44.95 + \$3 S/H (CAL residents add 6%)

OASIS DESIGNS

61159 El Coyote Ln., Joshua Tree, CA 92252
619-366-8570

Inquiry 689.

SOFTWARE/GRAPHICS

PROFESSIONAL GRAPHICS FOR SCIENTISTS AND ENGINEERS PC/MSDOS • Macintosh

FREE 48 page Catalog

Linear/Log Scaling • Graphs with error bars • AUTO PLOT • BATCH Mode • Multiple Y-axes • Multiple data files • Auto/ Forced Scaling • Full labeling • Built-in editor • 1-2-3 Interface • Curve fitting • Statistics • CGA, EGA & Hercules Compatible. 40 pen plotters supported.

BV Engineering Professional Software

2023 Chicago Ave., Suite B13, Riverside, CA 92507
VISA/MC (714) 781-0252

Inquiry 694.

SOFTWARE/GRAPHICS

FORTRAN PROGRAMMER?

Now you can call 2-D and 3-D graphics routines within your FORTRAN program.

GRAFATIC: screen routines \$135
PLOTATIC: plotter driver 135
PRINTMATIC: printer driver 135

For the IBM PC, XT, AT & compatibles. We support a variety of compilers, graphics bds., plotters and printers.

MICROCOMPATIBLES

301 Prelude Dr., Dept. B, Silver Spring, MD 20901 USA
(301) 593-0683

Inquiry 700.

FREE ENGINEERING MAGAZINE

Personal Engineering is a monthly magazine sent free of charge (USA only) to scientists/engineers who use PCs for technical applications. Topics each month include **Instrumentation • Data Acq/Control • Design Automation**. To receive a free sample issue and qualification form either circle below or send request on letterhead to:

Personal Engineering Communications

Box 300, Brookline, MA 02146

Inquiry 690.

TurboGeometry Library

Over 150 2&3 dimensional routines, includes Intersections, Transformations, Equations, HiddenLines, Perspective, Curves, Areas, Volumes, Clipping, Planes, Vectors, Distance, Polydecomp, IBM PC and Comp. MAC. MS-DOS 2+. Turbo Pascal, Turbo C, MSC & Turbo Pascal MAC. 400 pg. manual, source code. \$149.95 + 5.00 S&H. Foreign add \$16.00. VISA, MC, Chk, PO. 30 Day guarantee.

Disk Software, Inc.

2116 E. Arapaho Rd., #487, Richardson, TX 75081
1-800-635-7760
(214) 423-7288 FAX: 214-423-4465

Inquiry 695.

STANDARD GRAPHICS

PC_VDI graphics toolkit. Optimized, ANSI, ISO, CGI compatible. Mapping, arcs, compound text, orient, align, font loading, figure fill, image, bundles & hundred more. Segmentation, virtual mem support, transformation, bitblt, pattern fill, input option set. DRIVERS, print, plotter supp. Works with most "C", MS "QuickBASIC", "FORTRAN", EGA/VGA. Demos, manual. \$395. Amex accepted. Ask about OS/2 version.

NOVA, INC.

P.O. Box 68876, Schaumburg, IL 60168
312-882-4111

Inquiry 701.

EC-Ace ANALOG CIRCUIT ANALYSIS

You can afford to get started with EC-Ace, a subset of the powerful ECA-2 circuit simulator. Includes all the basics and built-in graphics.

- AC, DC, Temperature, Transient
- A full 525 pg. ECA-2 manual.
- Interactive, twice as fast as SPICE.

EC-Ace 2.31 IBM PC or Mac \$145.

Call 313-663-8810 for FREE DEMO

Tatum Labs, Inc.

1478 Mark Twain Ct., Ann Arbor, MI 48103

Inquiry 691.

SEGS v2.0

Scientific Engineering Graphics System

- Logarithmic, Time/Date & Linear Axes.
- Easy Curve Fitting and Data Smoothing.
- 1-2-3 Interface & Numeric Spreadsheet.
- Supports all Video & Device Standards.
- 10 Curves with up to 8000 points each.

Edmond Software, Inc.

5900 Mosteller Dr. #1124 405-842-0558
Oklahoma City, OK 73112 800-284-3381

Inquiry 696.

SOFTWARE/INVESTMENTS

Compare over 1,300 Mutual Funds with Business Week's Mutual Fund Scoreboard and your IBM PC or compatible. Use simple menu commands to search and sort on over 25 information fields. No additional software required. Data transports easily to Lotus 1-2-3 Search, total, average, rank, display and print reports—at the touch of a key!

Only \$69.95 each for an Equity or Fixed Income Diskette
\$199.95 per subscription for either the Equity or Fixed Income version
\$319.90 for a subscription to both versions (a savings of \$80!)

Order now or receive more information by calling 1-800-553-3575
(In Illinois, call 1-312-250-9292)

Or write to: **Business Week Diskettes**

P.O. Box 621, Elk Grove, IL 60009

Inquiry 702.

68HC11 SIMULATOR

\$95.00

Test software written for the 68HC11 on an IBM/PC/XT/AT or 100% compatibles. Single stepping, trace mode, breakpoints, interrupts, disassembler, EPROM simulation, much more! Tool for students and professionals. Check/Visa/MC.

FAX (604) 294-9996 Brochure available

WestShore Products

22549 Kendrick Loop, Maple Ridge, B.C. Canada V2X 5W4
(604) 291-1179

Inquiry 692.

PEN PLOTTER EMULATOR

FPLOTT turns your dot matrix or laser printer into an HP pen plotter. Fast hi-res output. No jagged lines. Vary line width, color. Works with Autocad, Drafrix, etc. Supports NEC P5/P6, IBM Proprinter, Epson LQ/FX, Toshiba, HP Laserjet, Hercules/CGA/EGA/VGA for preview. \$64 check/m.o.

FPLOTT CORPORATION

24-16 Steirway St., Suite 605, Astoria, NY 11103

212-418-8469

Inquiry 697.

STOCKS OPTIONS FUTURES

Turn Your PC Into A

MARKET QUOTATION MONITOR

100 page book covers satellite and radio data reception of financial news and quotes for your PC, \$19 (includes demo diskette). Free informative catalog of

- Data receivers and kits
- Quote processing and display software
- Descrambling software utilities

303-223-2120 \$5 Demo Diskette

DATArx

111 E. Drake Rd., Suite 7041, Fort Collins, CO 80525

Inquiry 703.

SOFTWARE/LANGUAGES

FORTRAN77 PROGRAMMER'S ASSISTANTS FREE YOU FOR MORE CREATIVE WORK

ASSISTANT I—12 productivity tools (beautifier, checker, documenter, function maker, action chart, etc.) & a source library with 300 essential subroutines. (MS-DOS) \$245
ASSISTANT II—FORTRAN77-to-C translator with run-time library (sour e) & 4 C productivity tools. (MS-DOS) \$475 demo \$10. 30-day money back guarantee. ORDER NOW!!

MicroTools

1082 E. El Camino Real #5, Sunnyvale, CA 94087
(408) 243-7688

Inquiry 693.

SOFTWARE/GEOLOGICAL

GEOLOGICAL CATALOG

Geological software for log plotting, gridding/contouring, hydrology, digitizing, 3-D solid modelling, synthetic seismogram, fracture analysis, image processing, scout ticket manager, over 50 programs in catalog. Macintosh tool. Please call, or write, for Free Catalog!

RockWare, Inc.

4251 Kipling St., Suite 595, Wheat Ridge, CO 80033 USA
(303) 423-5645

SCIENTIFIC POWER GRAPHICS

HGraph - graphics library. 100+ device independent routines for PC, SUN, Mac, VAX. Supports most graphics adapters, printers & plotters. Links with FORTRAN, Pascal, C, Modula-2 & Basic. \$119

UGraph - graphics presentation program. No programming, use your data or generate within. Special functions, FFTs, complex matrices. Designed for speed, ease of use; tailor to meet your needs! \$365
Custom software development.

HeartLand Software, Inc.

"Scientific Software Specialists"
234 S. Franklin • Ames, IA 50010 USA
• (515) 292-8216 •

Inquiry 698.

GRAPHICS PRINTER SUPPORT

AT LAST! Use the *PrintSc* key to make quality scaled *B&W* or color reproductions of your display on any dot matrix, inkjet, or laser printer. *GRAFPLUS* supports all versions of PC or MS-DOS with IBM (incl. EGA, VGA), Tecmar, and Hercules graphics boards. \$49.95.

Jewell Technologies, Inc.

4740 44th Ave. SW, Seattle, WA 98116
800-628-2828 x 527 (206) 937-1081

Inquiry 699.

EASY TO C

The C Workshop interactive software teaches you C. Do real C program exercises with built-in editor and compiler. Feedback guides you to solution. All you need to learn C, including our 384-page book. \$69.95 + \$5 Ship. PC compatibles.

MC/VISA/AmEx/Check.

Wordcraft

3872 Penniman Ave., Oakland, CA 94619
(800) 762-8003 (PST) (415) 534-2212 In CA

Inquiry 705.

THE BUYER'S MART

SOFTWARE/MAPS

MAPIT

Make your own MAPS!!

Simple to produce maps with your data. Includes most country and state outlines. Any printer or HP plotter.

Only \$95 for MS-DOS or PC-DOS
US County Outlines available for \$95.
QSC Box 778, East Lansing, MI 48826
(517) 641-4428

Inquiry 706.

SOFTWARE/MATHEMATICS

MATH EDITING FOR THE PC

$$x_i^2 = \sum_{k=0}^{\infty} [x_k^{2n} \binom{n}{k}] + \left(\frac{1}{\sqrt{\alpha \pm \beta x}} \right)$$

- MathEdit constructs math equations to be inserted into WordPerfect and TeX documents.
- User-friendly interface—no new word processor needs to be learned
- MathEdit—\$149

K-TALK COMMUNICATIONS

50 McMillen Ave., Suite 100
Columbus, Ohio 43201
(614) 294-3535

Inquiry 707.

MATHEMATICIANS—ENGINEERS

Have you ever seen functions of a complex variable? Would you like to really understand differential operators like div, grad and curl? How about a peek into the fourth dimension? Call or write for information on our latest PC and Macintosh software.

Lascaux Graphics

3220 Steuben Ave., Bronx, NY 10457
(212) 654-7429

Inquiry 708.

Derive™

A Mathematical Assistant

Makes math more inspiration and less perspiration! Combines the power of computer algebra with 2D & 3D plotting and a friendly menu-driven user interface. Does equation solving, calculus, trigonometry, vector & matrix algebra, and more. Derive requires a PC compatible computer & 512K memory.

Soft Warehouse, Inc.

3615 Harding Ave., Suite 505, Honolulu, HI 96816
(808) 734-5801

Inquiry 709.

SOFTWARE/MUSIC

IBM MUSIC FEATURE CARD!

Option card with 8 voice, multi-limbral MIDI synthesizer on board. Includes 240 pre-programmed Yamaha sounds, 96 programmable patches and a MIDI In/out/Thru interface. Use two cards to double capacities. An all-in-one MIDI Studio for IBM and compatibles for only \$495. Software available for recording, arranging and educational needs. Packages recommended. Dealers, catalogers, & VARS call for discount schedule.

Distributed by MIX BOOKSHELF

8400 Hollis St., #12, Emeryville, CA 94608 (415) 653-3307
1-800-233-9604

Inquiry 710.

SOFTWARE/PACKAGES

HARD TO FIND COMPUTER SUPPLIES FOR SOFTWARE DEVELOPERS & POWER USERS

Cloth binders & slipcases like IBM's. Vinyl binders, boxes, and folders in many sizes. Disk pages, envelopes, & labels. Low quantity imprinting. Bulk disks. Everything you need to bring your software to market. Disk and binder mailers. Much more! Low Prices! Fast service. Call or write for a FREE CATALOG.

Anthropomorphic Systems, Limited

376 E. St. Charles Rd., Lombard, IL 60148
1-800-DEAL-NOW 312-629-5160

Inquiry 711.

SOFTWARE/PACKAGE

SAVE SAVE SAVE SAVE LET'S TALK LABELS

We do disk labels (5 1/4" & 3 1/2")
• Better • Faster • Cheaper •
Because we specialize in disk labels... Let's Talk

We also have Tyvek Sleeves
Mailers • Binders • Vinyl Pages
We are a complete software packaging service.
Hice & Associates
9303 Cincinnati-Columbus Rd., West Chester, OH 45069
513-777-0133

Inquiry 712.

SOFTWARE/PRINTER

PRINTER GENIUS

Powerful memory resident printer management • Control printer features from menus or within documents • Print spool to disk files or memory • Background print • File & directory browse • Edit small text • and more... • User friendly pop-up screens • 92 page manual • Preset for all printers • Completely flexible • PC MS-DOS • \$89 + \$4 S/H • VISA/MC

Nor Software Inc.

527 3rd Ave., Suite 150, New York, NY 10016
(212) 213-9118

Inquiry 713.

SOFTWARE/SCANNERS

Optical Character Recognition

Stop retyping: PC-OCR™ software will convert typed or printed pages into editable text files for your word processor. Works with HP ScanJet, Panasonic and most other scanners. Supplied with 18 popular fonts. User trainable; you can teach PC-OCR™ to read virtually any typestyle, incl. foreign fonts. Proportional text matrix printer output, Xerox copies OK. \$385. Check/VISA/MC/AmExp/CO

Essex Publishing Co.

P.O. Box 391, Cedar Grove, NJ 07009
(201) 783-6940

Inquiry 714.

SOFTWARE/SCIENTIFIC

DATA ACQUISITION & ANALYSIS ON PC'S

- Free application assistance. Tell us about your DSP, process control, A/D or D/A needs. Our expert engineering staff will provide you with a system solution to fit your needs and budget.
- A/D & IEEE-488 boards from Metrabyte, Scientific Solutions and National Instruments.
- Analysis software including PRIME FACTOR FFT subroutine library, FOURIER PERSPECTIVE II advanced linear systems analysis.
- Menu driven software from Unitek, Laboratory Technologies, Quim-Curis, and Gold n. Scientific Engineering 2 & 3D graphics.

See "What's New" page 80, BYTE July, 1988

LOW PRICES—Satisfaction GUARANTEED

ALLIGATOR TECHNOLOGIES

P.O. Box 9706, Fou tain Valley, CA 92708
Tel. (714) 850-9984 FAX. (714) 850-9987 MCI. ALLIGATOR

Inquiry 715.

POWERFUL EQN SOLVER

RISK FREE \$99 OFFER With Top 10 Word Processor!
"Simple to differentiate or integrate." SCI.Soft
Graph across singularities • Non Linear • Coupled (singular) diff eqn • Any order any number • Indefinite (singular) integrals • New functions/algorithms/solutions • Fit 60th order curves to imported data • COMPLEX/real roots • Programming • 47 predefinitions • 14 digit accuracy • More • Dev. over 40 years' EETimes • MS-DOS, 640KB, graphics card • CURVE™

CALL TODAY • 800-648-5353 x100

VISA/MC/CODI/Check

Curve Systems International

11693 San Vicente Blvd., Suite 350, L.A., CA 90049

Inquiry 716.

C SCIENTIFIC LIBRARY

Extensive library of matrix, mathematical, and statistical routines. Developed and documented for use by technical specialists and C programmers in research, education, engineering, and scientific applications. Over 550 functions, superior documentation—four manuals, including Tutorial, Function Pages, and Example Programs. Includes Real and Complex Linear Algebra, Eigensystems, Differential Equations, Quadrature, Smoothing, Filtering and Prediction, Multivariate Statistics, Multi-Dimensional Optimization, Linear Programming, Curve Fitting and Interpolators, etc. \$295 object only and \$395 with C source code.

EIGENWARE TECHNOLOGIES

13090 La Vista Dr., Saratoga, CA 95070 (408) 867-1184

Inquiry 717.

SOFTWARE/SCIENTIFIC

ORDINARY/PARTIAL DIFFERENTIAL EQN SOLVER

FOR THE IBM PC & COMPATIBLES

MICROCOMPATIBLES INC.

301 Prelude Dr., Silver Spring, MD 20901
(301) 593-0683

Inquiry 718.

OUR CATALOG WILL SAVE YOU TIME AND MONEY!

It describes (i) GRAPH, a \$79 scientific plotting program, (ii) MINSQ, a powerful \$179 package for curve fitting and model development, (iii) LAPLACE, a simulation program employing numerical inversion of transforms (\$249), and (iv) RSTRIP for exponential stripping (\$249). Call today for our free 16 page catalog with detailed technical application notes.

MicroMath Scientific Software

Salt Lake City, Utah 4121-3144
For orders or catalogs call: (800) 942-MATH

Inquiry 719.

Scientific/Engineering/Graphics Libraries Turbo Pascal, Turbo C, Microsoft C

Send for FREE catalogue of software tools for Scientists and Engineers. Includes: Scientific subroutine libraries, device independent graphics libraries (including EGA, HP plotter and Laserjet support), scientific charting libraries, 3-D plotting library, data acquisition libraries, menu-driven process control software. Versions available for a variety of popular languages.

Quinn-Curtis

1191 Chestnut St., Unit 2-5, Newton, MA 02164
(617) 965-5660

Inquiry 720.

Scientific Software

Scientific CALCULATOR parallel processing & graphics, Sci.NOTEPAD free-form data management, DIALSEARCH literature searches, SCI.GRAPHPAD and SCI.STARPAD graphics-aided data analysis (log/semilog plots, error bars, curve fit, more). From \$85-On 5 1/4 and 3 1/2" MS-DOS disks. 30 day \$ back. VISA/MC/PO. Also see our ad under LANGUAGES.

Scientific LOGICS Inc.

21910 Alcazar Ave., Cupertino, CA 95014
(408) 446-3575 Compuserv 74017,663

Inquiry 721.

SOFTWARE/SECURITY

CodeSafe™ Virus Protection System

Thousands of copies in use since 1986 • Protects all hard disks, any size • Protects all COM and EXE files. Not just the system files (like other products) • Detects corruption of Boot sector, and DOS • Supports all PC/MS-DOS machines • DOS 2.0 to 4.0 • Mono, Hertz, CGA, EGA • Includes both 5 1/4" and 3 1/2" disks • Transparent to user • Warning windows will open, with options if a problem occurs • Memory resident approx. 10 to 2 K, depending on the number of files.

TOLL-FREE TECH SUPPORT @ 30 Day Money Back Guarantee
NOT COPY-PROTECTED \$89.95 Visa and Master Card accepted

ChrisWare, Inc.

15415 N. Eden Dr., Eden Prairie, MN 55346

24 HOUR SERVICE TOLL FREE 1-800-325-8448

Inquiry 722.

PC Security Products

A complete line for: PC access, back-ups, modems, software piracy, virus detection, file encryption, and data protection. Featuring CodeSafe H/W copy protection with sophisticated file encryption. Brochures and Demos available.

Gamma Security Products

710 Wilshire Blvd., #609, Santa Monica, CA 90401
Tel: 213/394-8622 Fax: 213/395-4214 Tlx: 510600 273

Inquiry 723.

THE BUYER'S MART

SOFTWARE/SECURITY

HANDS OFF THE PROGRAM®

- Locks Hard Disk. - Restricts Floppy Use.
- Protects Subdirectories.
- Normal Use of DOS Commands and Application Software.
- IBM PC, XT, AT and True Compatibles.
- DOS V2.0 and Higher. Hard Disk System.
- Keep Other People's HANDS OFF Your System
- \$89.95 VISA/MC

SYSTEM CONSULTING, INC.

314 Canterbury Dr., Pittsburgh, PA 15238
(412) 963-1624

Inquiry 724.

SOFTWARE/SORT

OPT-TECH SORT/MERGE

Extremely fast Sort/Merge/Select utility. Run as an MS-DOS command or CALL as a subroutine. Supports most languages and filetypes including Btrieve and dBASE. Unlimited filezites, multiple keys and much more! MS-DOS \$199. XENIX \$249.

(702) 588-3737

Opt-Tech Data Processing

P.O. Box 678 - Zephyr Cove, NV 89448

Inquiry 725.

SOFTWARE/STRATEGIC

WANTED: CEO, Compaq Corp., or Microsoft, or Chrysler, or Union Carbide, or Georgia Pacific, or...

Business Week's Business Advantage simulation software puts you behind the desk of some of the most powerful business leaders in America. You make the decisions, you deal with competition, you set the strategy, you face the consequences. This exciting simulation has fourteen Chief Executive positions open, and is available in both PC and Mac formats. Only \$69.95 puts you in one of these shoes. Additional cases available for only \$29.95. (plus \$5.00 shipping and handling). To order, or for more information, please call:

BUSINESS WEEK

620 Strategic Management Group Inc.
3624 Market Street, Philadelphia, PA 19104
1-800-445-7089

Inquiry 726.

SOFTWARE/TAX PREP

TAX PAK

5th year—Sched A B C D E F R S Frms 1040 1040A 1065 2106 2119 2441 3468 3800 3903 4137 4562 4684 4797 4972 6251 6252 8582 8606 8615. IRS approved printing for IBM PC. Professional allows multiple clients, Batch Processing, & Tax Organizer: \$185. Personal has abbreviated list of forms & features \$37: Annual updates \$125 & \$27 respectively.

Candelaria Works

3955 Club Dr., Atlanta, GA 30319 (404) 266-2420

Inquiry 727.

APRIL 15th™

Tax preparation package based on Lotus 1-2-3, 2.0 for IBM-compatible PC w/512K. Includes 1040, 1040A, all Schedules & 12+ supporting forms. IRS-acceptable printouts (except 1040, 1040A). Easy-to-use menu functions & Help files, 1988 Version \$49.95. Low-cost '87 demo available for '88 tax planning.

JD Enterprises

P.O. Box 658 St. Ann MO 63074
(314) 427-3353

Inquiry 728.

1988 TAXES FAST, EASY, ACCURATE

IBM/Compatibles, Commodore-Amiga. Prints forms, audits taxes, multiple returns, 20 forms and schedules, saves to disk, forecast 1989 taxes. ONLY \$34.95. Add \$4 S/H, MA add 5% Sales Tax, Check, M.O., Credit Cards.

Quality Business Systems

P.O. Box 805, Hudson, MA 01749
1-800-225-5800

Inquiry 729.

STATISTICS

The BASS System™

Why use up 8 meg and 640K just to run a data step on your PC? Now you can run your data step code and statistical procs with a system that takes only 1 meg and 400K (and costs only \$399)! Free information:

BASS Institute, Inc.

P.O. Box 349, Chapel Hill, NC 27514
(919) 933-7096 or BB: (919) 968-6755 (N,8,1)

Inquiry 730.

STATA

NEW RELEASE NOW AVAILABLE. Even better graphics, expanded on-line help, and much more. Still only \$590. Quantity and Academic Discounts available. \$20 Demo. Call toll-free for more information. AX/VISA/MC.

1-800-STATAPC Computing Resource Center

10801 National Boulevard, Los Angeles, CA 90064
(213) 470-4341

Inquiry 731.

STATISTICS CATALOG!

Call for the catalog full of professional programs for general statistics, analysis of variance, regression, questionnaire analysis and quality control. Thoroughly tested and easy to use, the programs come with complete documentation. Programs available for PC or Apple II. Call toll free now for your free catalog.

HUMAN SYSTEMS DYNAMICS

9010 Reseda Blvd., Suite 222
Northridge, CA 91324

(800) 451-3030 (818) 993-8536 (CA)

Inquiry 732.

STATISTICAL NAVIGATOR™

Statistical Navigator an expert system using AI strategies to help guide the researcher to the appropriate statistical analysis. Based on your answers, it suggests several analyses ranked by suitability. It explains what the analysis does and how it fits your objectives and assumptions. Special intro price \$99.95+sh.

VISA/MC/AMEX/PO, 30 day-guarantee.

The Idea Works, Inc.

100 West Briarwood, Columbia, MO 65203
1-800-537-4866 314-445-4554

Inquiry 733.

SIR/DBMS DEMO KIT (7.5 Mb) \$49.95

Since 1976, SIR/DBMS has PIONEERED Advanced DBMS Technology DESIGNED to handle the changing complexities of Scientific, Engineering, and Research Database Management. SIR/DBMS is also DESIGNED to provide THE BEST DIRECT interfaces to SAS, SPSS, BMDP, & SYSTAT. SIR/DBMS offers True Application Level Portability from PCs thru Supercomputers!

MAYBE YOU SHOULD TRY SIR/DBMS??

Order Now! Ref Buyer's Mart Special Offer!

SIR, A Division of Inter Systems Inc.
312-480-9270 (IL) 703-642-1600 (VA)

Inquiry 734.

MINITAB's a PC of cake!

MINITAB's intuitive commands are easy to use and remember. Features descriptive statistics, regression, time series, chi-square, hi-res graphics, much more. PC version incl. LOTUS interface, 30-day trial, network pricing. Call for FREE brochure.

Minitab, Inc.

3081 Enterprise Dr., State College, PA 16801
(814) 238-3280

Inquiry 735.

STATISTICS

NCSS

Professional, easy to use, menu driven statistical system. Used by over 5000 researchers.

- 5.0 Statistical System —\$99
- 5.1 Graphics (2D & 3D)—\$59
- 5.3 Power Pac Supplement—\$49
- 5.4 Exp. Design/QC—\$49
- 5.5 Survival Analysis—\$59
- 5.6 Forecasting—\$69

We accept checks, PO's, Visa, MC. Add \$3 s/h.

NCSS-B 801-546-0445

865 East 400 North, Kaysville, UT 84037

Inquiry 736.

STATISTIX™ II

Comprehensive, powerful and incredibly easy-to-use. Full screen editor, transformations, linear models (ANOVA, regression, logit, PCA, etc), ARIMA, most standard stat procedures. Clear, well organized documentation. Satisfaction guaranteed. \$169 PC DOS, \$99 Apple II.

NH ANALYTICAL SOFTWARE

P.O. Box 13204, Roseville, MN 55113

(612) 631-2852

Inquiry 737.

StatPac Gold™

StatPac Gold is the award-winning statistics and forecasting package that delivers. It's fast, flexible, easy to use and dependable. Time-tested and loaded with features. You be the judge. Get the facts! Call for your FREE brochure.

1-800-328-4907

Walonick Associates, Inc.

6500 Nicollet Ave. S., Minneapolis., MN 55423
(612) 866-9022

Inquiry 738.

UTILITIES

VIDEO SYSTEM TEST

This menu-driven utility tests your PC/XT/AT video monitor and controller board combination for compatibility with 17 video modes, including 8514/A, VGA, EGA, CGA, and Hercules. Also provides test pattern for screen adjustment. \$25.

Adventa Corporation

1016 E. El Camino Real, Ste 223, Sunnyvale, CA 94087
(408) 946-8545

Inquiry 739.

Class-A-File

A database for your DOS files. Automatically tracks last access, update, and creation dates. You classify each file, specify ownership, attributes and description using pop-up interface accessible from any program. Class-A-File sorts and reports according to your selection. Like adding secondary keys to the DOS files system. \$69.95.

Automation Technology Research

4790 Irvine Blvd. #105-376, Irvine, CA 92720
(714) 838-6607

Inquiry 740.

STILL RIVER SHELL NEW VER. 2.58

ELEGANT INTERFACE TO DOS. Faster more powerful version of this popular DOS shell. Find, copy, move, delete files in a few keystrokes. *Tagging. *Find on name and text. *Full Tree. *User defined commands and more. \$39 complete with 160pp. manual. Unltd. site lic. \$390. MC/VISA. 90-Day No-Risk Guarantee.

BILL WHITE

PO Box 57, Still River, MA 01467
(508) 456-3699

Inquiry 741.

THE BUYER'S MART

UTILITIES

MATCH PRINTERS TO PC

For less than \$30 **MatchFont** and **Match-a-Printer** are great for foreign and scientific writings. Get all the characters you need from most programs and printers (Apple & Epson printers, daisywheels, etc.). Greek, French, Italian, Spanish, German, Swedish, Japanese, graphics. . . You name it! To receive a demo disk send \$5 refundable upon purchase to: Call or write 818-906-6791

MATCH SOFTWARE

6426 Coldwater Canyon, North Hollywood, CA 91606-1113

Inquiry 742.

UTILITIES

XPage Breaks 640k!

Why buy expensive EMS boards? OS/2 is not going to use it. XPage turns your PC/XT/AT hard disk space or AT extended memory as EMS memory. It's compatible with most DOS EMS applications. Write for free information or send check/money order \$39 + \$3 s/h to:

RMC Technologies

7 Baron Park La., #21, Burlington, MA 01803
(617) 272-8208

Inquiry 746.

WORD PROCESSING

FARSI / GREEK / ARABIC / RUSSIAN

Hebrew, all European, Scandinavian, plus either Hindi, Punjabi, Bengali, Gujarati, Tamil, Thai, Korean, Viet, or IPA. Full-featured multi-language word processor supports on-screen foreign characters and NLQ printing with no hardware modifications. Includes Font Editor. \$355 dot matrix; \$150 add'l for laser; \$19 demo. S/H in U.S. incl'd. Req. PC, 640K, graphics. 30 day Guarantee. MC/VISA/AMEX

GAMMA PRODUCTIONS, INC.

710 Wilshire Blvd., Suite 609, Santa Monica, CA 90401
213/394-8622 Tlx: 5106008273 Gamma Pro SNM

Inquiry 750.

BRIDGE-IT 3.5

This device driver supports 3 1/2 drives in both 720K and 1.44mb capacity on PC/XT/AT model compatibles without upgrading DOS or changing BIOS. Bridge the gap to PS/2 and laptop systems.

Only \$59 + \$4 S/H VISA/MC/COD UPS B/R

MICROBRIDGE COMPUTERS

655 Sky Way, San Carlos, CA 94070

ORDER TOLL FREE 1-800-523-8777

415-593-8777 CA FAX 415-593-7675
514-845-0818 (CAN)

Inquiry 743.

DATABASE UTILITIES

NORTAK Software Ltd. now offers a menu driven ASSIST-like file utility for dBASE, Clipper, and FoxBASE. Self-contained (.EXE file), fast and simple to use.

SINGLE VERSION—\$35; 3-VERSION PACKAGE—\$60.

To order call:

SHOSHIN Systems Inc.

USA 1-800-267-0755 Canada 1-800-267-8856

Info Only 613-235-2310

VISA and MC accepted

Inquiry 747.

JAPANESE WORD PROCESSOR FOR IBM

EW Plus is the first complete Japanese word processor for IBM PS/2 and AT. Contains about 8000 KANJI and KANA characters, as well as a 45000 word dictionary. Fully supports Japanese standards. Powerful Roma-ji to KANJI conversion. For IBM PS/2, AT, Toshiba laptops. Requirements: VGA, EGA, Hercules; 512k Memory; Hard Disk. Printers: Epson LQ 24 dot; IBM 9 pin, XL24; HP LaserJet.

For details call:

Information Technology Lab., Inc.

280 Park Ave., 4E, New York, NY 10017

TEL (212) 557-0177 FAX (212) 557-0179

Inquiry 751.

COPY AT TO PC

The 1.2mb drive has long been known to READ but NOT reliably WRITE on 360kb floppies. With "CPYAT2PC"™ 1.2mb drives CAN reliably WRITE 360kb floppies saving a slot for a second hard disk or backup tape. "CPYAT2PC" (Not Copy Protected) offers "the preferable SOFTWARE SOLUTION." ONLY \$79+\$4 S/H VISA/MC/COD UPS B/R

MICROBRIDGE COMPUTERS

655 Skyway, San Carlos, CA 94070

Order toll free 1-800-523-8777

415-593-8777 (CA) FAX 415-593-7675
514-845-0818 (Canada)

Inquiry 744.

LOGGER®

Logger, for IBM-PC and compatibles, tracks and reports: User, Time on, Time off, Directories used, Programs used, Program start/end time, and calculates totals. Tracks directories/files: Opened, Created, Renamed, Deleted. Completely transparent. Retail for \$74.95 with quantity discounts available.

System Automation Software, Inc.

8555 16th St., Silver Spring, MD 20910

1-800-321-3267 or 1-301-565-8080

Inquiry 748.

DuangJan

Bilingual word processor for English and: Armenian, Bengali Euro/Latin, Greek, Hindi, Khmer, Lao, Punjabi, Russian, Sinhalese, Tamil, Thai, Viet. . . \$109+\$5 s/h (foreign + \$12 s/h). Font editor included. For IBM with dot-matrix & LaserJet printer. Demo \$6 + \$1 s/h.

MegaChomp Company

3524 Cottman Ave., Philadelphia, PA 19149-1606

(215) 331-2748

Inquiry 752.

Recover deleted files fast!

Disk Explorer now includes automatic file recovery. You type in the deleted file's name, Disk Explorer finds and restores it. Disk Explorer also shows what's really on disk; view, change or create formats, change a file's status, change data in any sector. MS-DOS \$75 U.S. Check/Credit card welcome.

QUAID SOFTWARE LIMITED

45 Charles St. E. 3rd Fl.

Toronto, Ontario, Canada M4Y 1S2

(416) 961-8243

Inquiry 745.

\$79.95!!

Order the RED Utilities now! Programs include: Disk cache speeds hard and floppy disks. Printer spooler. Batch file compiler speeds batch files. Path command for data files. Wild card exceptions. Sort directories. Over 10 more programs. IBM PC. Visa/MC. Send for free catalog.

The Wenham Software Company

5 Burley St., Wenham, MA 01984 (508) 774-7036

Inquiry 749.

PC-Write 3.0 — Shareware

Fast, full featured word processor for IBM PC. Now edits large files & multiple columns. Also spell check, mailmerge, networking, ASCII, and macros. Easy to use, optional menus. Supports 500 printers incl. lasers. Software, guide and tutorial on disk: \$16. Registration with manual, support newsletter and 2 free updates: \$89.

90 day money back guarantee. VISA/MC.

Quicksoft

1-800-888-8088

219 First Ave. N., #224-BYTC, Seattle, WA 98109

Inquiry 753.

BBS SYSOPS

Are you looking for ways to improve your board? Something that will set you apart from the other boards in your area? Are your subscribers interested in Microcomputers? Listen to this!

Announcing the Bulletin Board EXchange — BBX

The BBX allows you to become a publisher of MicroBYTES Daily, an on-line news service from BYTE. BBX/MicroBYTES is a custom package of news and features designed specially for local BBSes, and is available only to sysops.

Every Monday through Friday you get articles about developments in microcomputing, telecommunications and selected new product announcements. Get the latest news MSDOS machines, Macintosh, Unix workstations, peripherals and software. All the stories are reported, written and edited by the staff of BYTE Magazine, BYTEweek and BIX. With BBX/MicroBYTES your board will have access to our world-wide network of reporters and editors.

Not only do you get a great resource for your subscribers, but you also get access to BIX which will cut your cost of exchanging information and conducting BBS network business.

All this is only \$199 per year. If you call BIX directly you pay no hourly rates.

If you call using Tymnet the rates are only \$2/hr on evenings and weekends and \$8/hr on weekdays.

Subscribe today.

BIX

One Phoenix Mill Lane
Peterborough, NH 03458
1-800-227-2983 ♦ In NH (603) 924-7681

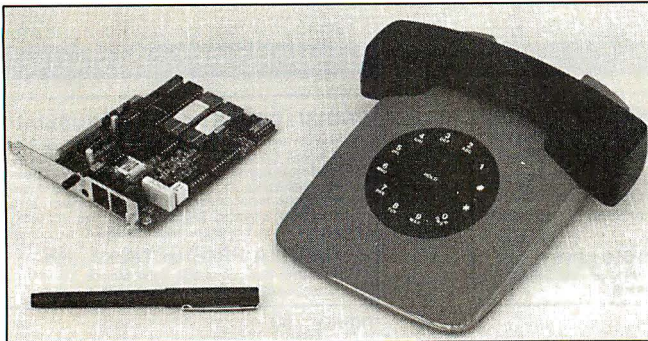

**\$95 2400 BAUD MODEM
30 DAY FREE TRIAL !**

Many low cost modems are faulty or very error prone. . . **Not ours!!** **PERFORMANCE...** "I have recently had a lot of trouble getting 2400 BAUD MODEMS to work... this one is working perfectly." R.T. Moreno Valley CA. **SUPPORT...** "I get the impression that your company indeed, bends over backwards to provide service to its customer." M.F. Selma CA. **SUPERIOR TECHNOLOGY...** The phone connection is the main source of data errors. **DYNAMIC IMPEDANCE STABILIZATION, DIS** (invented by CompuCom) improves signal quality and reduces errors by up to 95% compared to a standard modem. Model 2400 (without DIS) at \$95 outperforms the low cost alternatives, the 24DIS at \$119 outperforms the challengers, regardless of cost. IBM internal, made in USA, 6 COM ports, internal speaker, five year warranty, software included, dealers inquire. *If you aren't totally satisfied, return within 30 days for a full refund!*

March '89p102
"Real deal. . .worked fine. . .quite a bargain." **BYTE MAGAZINE**
CALL FOR DETAILS

CompuCom Corporation (800) 228-6648

**PC COMPATIBLE
ENGINEERING**

Annabooks gives you the **hardware, software, and firmware** information you need to design PC-compatible systems faster and better. And you have control of your design from the ground up -- our firmware and software products include **source code!** Plus all the utilities you need. Do hardware design? **Declar Design's** 1M DRAM SuperSpec is the first of a series of hardware books you won't want to miss. And a PC Bus timing book is on the way! Start by getting these books:

AT BiosKit: an AT Bios with source code you can modify. With setup & debug. 380 pages with disk, \$199

XT BiosKit: Includes a debug. 270 pages with disk, \$99

Intel Wildcard Supplement for XT BiosKit: Includes ASIC setup, turbo speeds, 60 pages with disk, \$49

1M DRAM SuperSpec: Design your memory to all mfg's specs at once! Lots of timing diagrams & tables, \$79

PromKit: Puts anything in Eprom or SRAM; DOS, your code, data, you name it! With source on disk, \$179

SysKit: Here's a debug/monitor you can use even with a brand X Bios. Includes source, of course. \$69

XT-AT Handbook: The famous pocket-sized book jam-packed with hardware & software info. \$9.95 ea. or 5 or more for \$5 each.

Software tools: You need MS C & MASM 5.1 for modifying the Kit products.

FREE Mention this ad when you order and get a **free XT-AT Handbook** by Choisser & Foster! Hurry before we come to our senses and change our minds.

Annabooks

12145 Alta Carmel Ct Suite 250-262
San Diego, California 92128



(619) 271-9526 Money-back guarantee

**Important TIPS* for BYTE Subscribers:
Receive Product Information 10 Days Earlier!**

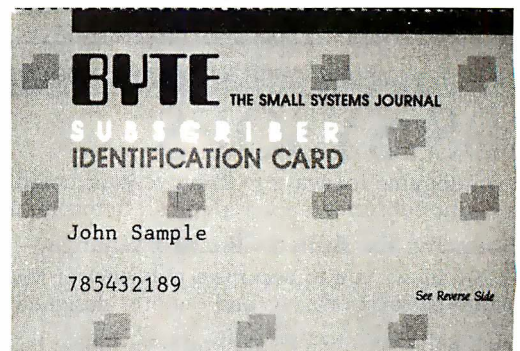

All you need is a touch-tone telephone and your subscriber I.D. number. See instructions facing the Reader Service Index in the back of this issue for outrageous time-saving opportunities!

*BYTE's Telephone Inquiry Processing Service

Compu\$ave



1-800-877-8855

International Orders are Welcome!

BOARDS	COMPUTERS	PLOTTERS	PRINTERS
Adv. Dig. Slave565 OrchidPro Design 295	Acer Computers Save Toshiba 1000 779	Calcomp 1023GT3779 Ioline 3500 2375	Alps Allegro 24342 NEC P5300 665
AST 5251-11E 545 Paradise VGA+ 258	Altos Computers Save Toshiba T1200F ... 1359	Calcomp 1043 GT5365 Ioline 3700 2995	Brother HL8E 2045 Panasonic 1080iM2 ... 159
ATVGA Wonder Save Paradise VGA + 16 ... 295	ALR Computers Save Toshiba T1200FB ... 1495	Calcomp 1044GT ... 10,239 Ioline 4000 3695	Canon BJ 130 699 Panasonic 1091iM2 ... 175
BOCA RAM AT 139 Quadram JT Fax 262	AST Premium 286 1299 Toshiba T1200HB ... 2345	Houston DMP 52 2295 JDL 850 GL 2799	Citizen120D 145 Panasonic 1124 Save
Genoa VGA HiRes 349 Sigma VGA H 238	AST Premium 386 2549 Toshiba T1600 3245	Houston DMP 61 2995 Roland 885 689	Citizen 180D 162 Panasonicalaser Save
Intel Above Board 395 STB VGA EM 512K ... 358	AT&T Computers Save Toshiba T3100E ... 2775	Houston DMP 62 3988 Roland 980 869	Diconix D150 294 Okidata ML320 329
Intel Inboard 386 Save Video 7 V RAM 468	Everex Computers Call Toshiba 3200 3465	HP 7475 A 1395 Roland DXY 1100 889	Genicom 3410 1499 Okidata ML 390 455
Metheus 1104 1029 Video 7 Vega VGA ... 259	Intel 25 Mhz Save Toshiba 5100 4575	HP 7550 A 2895 Roland DXY 1200 ... 1295	Fujitsu DL3400 519 Okidata 393C 1069
Adaptek, Alloy, Konan, Everex, Hercules Call	Mitsubishi 286/386 Save Toshiba 5200 6245	HP 7570A 2875 Roland GRX Save	HP Desk Jet 699 QMS Lasers Save
Imagraph, Number 9, Photon, Pixelworks Call	NEC Laptops Save Wyse 2108 949	HP Draft DXL 3699 Western Graphtec .. Save	HP Paint Jet 1049 Qume Crystal Print ... Save
Talltree, Tops, Verticom, VMI, West. Dig. Call	NEC Powermates Save Wyse 2112 1375	Bruning, Numonics, Mural, Taxan, Versatec Call	NEC LC 890 3089 Star NX-1000 165
DISK DRIVES	Packard Bell 12 Mhz ... 1249 Wyse 2200 1345	DIGITIZERS	NEC P2200 335 Star NX-2400 318
Maxtor 800 Worm ... 2999 Plus Hardcard 40 ... 638	Samsung 20 Mhz Save Wyse 3216 2125	Calcomp 12 x 12 348 Houston Hi Pad + .. Save	NEC P5200 505 Toshiba Express 301 ... 325
Micropolis 71 Mb 519 Rodime Apple HD ... Call	Televideo 286/386 Save Zenith Supersport ... 1579	Calcomp 44 x 60 3895 Kurta IS 12 x 12 ... 282	Brother, C.Itoh, Data Products, Epson Call
Miniscribe 3053 429 Seagate ST251-1 ... 398	Unisys286/386 Save Zenith SS 286 3265	Calcomp 36 x 48 3395 Kurta IS 12 x 17 ... 482	OTC, Seikohsa, TI, Varityper & Other Models Call
Miniscribe 40 Mb 309 Teac FD55 72	Mitsubishi MP286 Laptop : 20Mb 2298	GTCC 24 x 36 1945 Scriptel Save	MONITORS
Miniscribe 157 Mb ... 1159 Toshiba 1.44 Mb 9 9	Mitsubishi MP286 Laptop : 40Mb Save	GTCC 36 x 48 2395 Seiko Save	Amdek 1280 638 NEC Multisync GS Save
Miniscribe 338 Mb ... 1929 Toshiba 720 K, 3.5" ... 79	Altos, Sharp, Sperry, & Other Models Call	Hitachi 11 x 11 439 Summa 12 x 12 + ... 328	Amdek 732 399 NEC Multisync XL ... 2145
Archive, Alloy, Emerald, Genoa, Iomega Call	TERMINALS	Hitachi Puma Pro ... Save Summa 12 x 18 558	Conrac/Relisys Save PGS Ultra 16 879
Irwin, Mountain, Priam, Sysgen, Tecmar Call	Altos IV 355 Televideo 955 379	MODEMS	Genius 402/420 Save Samsung TTI 79
SOFTWARE	Altos V 485 Wyse 30 285	ATI 2400 ETC, Int. 152 Practical 1200I 65	Hitachi Save Sigma Laser 19" ... 1765
Carbon Copy Plus ... 107 Microsoft PC Works 91	IBM 3151 385 Wyse 50 355	Anchor 2400E 145 Practical 2400 PS/2 ... 225	Mitsubishi 1381A 475 Sony 1302 645
DBase IV Save Multimate Advan. II ... 259	Kimtron KT-70 PC 359 Wyse 60 392	Cardinal 2400 Int. ... 109 Prometheus 2400B/2 ... 129	Mitsubishi HL6605 ... 1229 Taxan Save
Desqview 386 105 PC Tools Deluxe 43	Link MC-5 392 Wyse 85G 375	Hayes 1200 Ext. 275 Prometheus 2400G ... 149	Moniterm Save Taxum CM1296 ... Save
Fastback Plus 104 Peachtree Complete .. 143	Televideo 905 299 Wyse 150 385	Hayes 2400 Ext. 415 Racal-Vadic 2400VP ... 388	Nanaco Flexscan Save Zenith 1490 578
Harvard Graph 279 Quattro 157	Adds, Ampex, HP, Sun River, & Other Models ... Call	Multitech 224 EC 305 USR HST 9600 588	Seiko CM 1430 : 14" Multisynch 1024x768 595
Lotus 123 295 Rightwriter 3.0 52	MICE	Multitech 224 EH 388 WorldPort Pocket Save	SCANNERS
Lotus Symphony 415 Top for DOS 105	Logitec C7 Serial 62 Microsoft w/ paint 99	Multitech 9600 499 Zoom 2400 Ext. 125	HP Scanjet 1399 PC Hand Scanner 152
Microsoft Excel 235 Ventura Publisher 489	Logitec HiRes Bus 78 Microsoft w/windows ... 132	Practical 1200 Ext. 76 Zoom 2400 HC 119	Logitec Scan Man ... 189 PGS LS-300 w/paint ... 725
Microsoft Word 4.0 ... 205 WordPerfect 5.0 229	Logitec PS/2 62 Mouse Systems PC II ... 89	AST, Avatec, Everex, Packard Bell, Ventel, UDS ... Call	AST, Datacopy, Dest, HP, Panasonic, Taxan Call

Mail Address: Compu\$ave - 4207 S. 37th Street - Dept B4 - Phoenix, AZ 85040. Order lines open: Mon.- Fri. 7 am - 6 pm. Sat.: 9 am - 2 pm. Prices reflect cash discounts and are subject to change without notice. We do not guarantee compatibility. DOA's are repaired or replaced, please call for a RMA. Major credit cards and selected PO's are accepted.

INTERNATIONAL SALES (602)437-4855 - FAX (602)437-9685 - CUSTOMER SERVICE (602)437-4856

COMPARE OUR NEW LOWER PRICES AND SUPERIOR QUALITY

PCI-286-12

- 80286-12
- 1.2 MB Floppy Drive
- 640K RAM
- Serial / Parallel / Game
- 101-Key Enhanced Key Board
- SI = 13.3 (1 Wait)
- SI = 15.2 (0 Wait \$100 Option)
- 6/12 MHz Key Board Switchable
- WA2 HD & FD Controller
- 80287 SOCKET
- 200W POWER SUPPLY

MONO SYSTEM

- W/Mono Monitor
- 20 MB Hard Disk

\$1195

- ### VGA COLOR SYSTEM
- W/VGA Card & Monitor
 - 20 MB Hard Disk

\$1795

- ### EGA COLOR SYSTEM
- W/EGA Card + Monitor
 - 20 MB Hard Disk
- \$1580**



PCI-386-20

- 80386-20
- W/40 MB HD
- Mono System **\$2295**
- EGA **\$2695**
- VGA **\$2995**

GAS PLASMA 286-12 ___ \$2295

- 80286-12 CPU
- SI = 13.3
- 3 1/2" FD 1.44 MB
- 20 MB HD ST-138
- LCD Screen (640 X 400)
- I/O Card Parallel/Serrial/Game
- 640K RAM

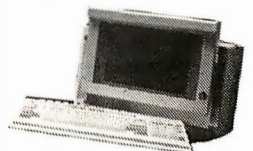

GAS PLASMA 286-20 ___ \$2495

- CPU 80286-20
- SI = 23

LCD-286-10 PORTABLE ___ \$1595.00

- 10 MHZ 80286 SI=10.3
- 12 MHZ SI = 13.3 (Option \$50.00)
- 16 MHZ SI = 18 (Option \$250.00)
- 640K RAM
- LCD Screen 640 X 200 (Option 640 X 400 \$180.00)
- Super Twist & Back Lighting
- 86 Key Board
- External / Parallel / Game
- 1.2 MB Floppy drive
- 20 MB Hard Disk
- 80287 Socket
- 200 W Power Supply
- Side 15 3/4" X 9 1/2" X 8"
- 23 LBS

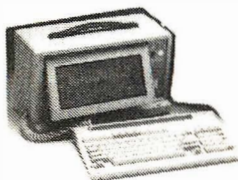

LCD-386-16 ___ \$2595.00

- 80386-16 MHZ
- 40 MB Hard Disk
- 80387 Socket

LCD-386-20 ___ \$2695.00

- 80386-20 MHZ
- 40 MB Hard Disk
- 80387 Socket

CRT-PORTABLE-286 ___ \$1389

- Compaq Type
- 80286 (10 MHz or 12 MHz)
- 12 MHZ SI = 13.3 (Option \$50.)
- 16 MHZ SI = 18 (Option \$250)
- One 1.2 MB Floppy Drive
- 200 W Power Supply
- TTL Disply 9" Amber
- AT Key Board
- Serial / Parallel / Game
- WA2 HD & FD Controller
- 20 MB Hard Disk

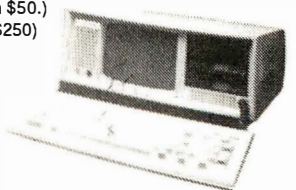

CRT-386-16 \$2395

- 80386-16

CRT-386-20 \$2495

PCI PACIFIC COMPUTER
702 S. Del Mar Ave., #B,
San Gabriel, California 91776
(FAX) 818-286-8662

(818) 571-5548 (Technical support)

(800) 421-1102 (IN CA) ORDER ONLY

(800) 346-7207 (OUT CA)

*ALL SYSTEMS COME WITH ONE YEAR PARTS & LABOR WARRANTY

Mon - Sat
9:00 AM - 6:00 PM



Save Your Data and Money, Too! Peripherals Sale!

Easy to Install!



Get the Best for Less!

This is the fastest floppy interface tape drive around!
40MB TAPE DRIVES
 Add \$10 for Shipping **\$279** 40MB Cartridge \$22

External model now available for only \$99 extra!

Works with all IBM PC, XT and AT computers and 100% compatibles. Connects to your floppy disk controller. Fully QIC-40 compatible.

Includes menu-driven software. This is the fastest floppy interface tape drive around. Save now on this top quality tape drive.



Total Power Protection!

UNINTERRUPTABLE POWER SUPPLY

As Low As **\$279** 250 Watt Model
 Add \$23 shipping in the lower 48 states.

250 Watt	120 Volt	\$ 279
300 Watt	120 Volt	399
500 Watt	120 Volt	499
600 Watt	120 Volt	639
1200 Watt	120 Volt	1099
1600 Watt	120 Volt	1444*

230 volt units also available. *Shipped motor freight collect. Specify exact input voltage.

Limited Time Only! Fantastic Prices Now On LOW COST HARD DRIVES For IBM and Tandy



21.4 Meg Kit **\$259** MFM 65ms
 32.7 Meg Kit **\$289** RLL 65ms
 42.8 Meg Kit **\$389** MFM 40ms
 65.5 Meg Kit **\$439** RLL 40ms

One year parts and labor. Add \$10 for shipping.

Don't spend more than necessary to add an internal hard drive to your IBM compatible. Clone provides the best low-cost, high-quality, fast access hard drives for your IBM XT, 100% compatible, or Tandy 1000/A/SX. They make a great addition to our Turbo Clone. These kits come complete with the drive, controller, cables and installation instructions. Our systems allow you to boot directly from the hard drive. We use brand new genuine Seagate drives, not some obscure reject off-brand, so you can be assured of long, trouble-free drive life. The average access times of our 20 and 30 megabyte drives are 65ms, and the 40 and 65 megabyte drives are a mere 40ms (28ms after partitioning). Not a slow-stepping dog in the

bunch. We provide software to park the heads for maximum protection (automatic on 40 and 65 megabyte models). All connectors and card edges are gold plated to insure flawless service. Tandy 1000/A/SX owners can save hundreds by simply removing one floppy drive and installing one of our low-power kits in its place. These sizes listed are after formatting. DOS 3.2 or later is required for the 30, 40 and 65 megabyte models. Tandy 1000 requires DMA and ROM 1.01.00 or later. Not for Tandy 1000EX/HX. 30 day satisfaction guarantee. If, for any reason, you don't like your hard drive, we'll refund the entire purchase price, less shipping. Please specify the brand and model of your computer when ordering.



Hurry! Supply Limited

Save Now on 30MB Hard Cards!

Easy to install! **\$319** While they last.

This unit comes completely assembled and is easy to install. It's ready to gobble up all those pesky floppy diskettes you have laying around the place. No preventive maintenance required. Low power use, so expansion capabilities are not limited. One year manufacturer's warranty comes with this little beauty. One model fits the Tandy 1000/1000A and 1000SX.

- **Blackouts.** Enables user to operate during complete loss of power.
- **Brownouts.** User is protected from low AC voltage below 102 volts.
- **Overload Protection.** Automatic shutdown in overload situation protects UPS from inverter burnout.
- **Overvoltage Protection.** UPS runs on inverter (117 volts) when AC voltage exceeds 132 volts.
- **Surges/Spikes.** Clamps transients above 200 volts with an energy rating of 100 joules or less.
- **EMI/RFI.** Three stage filtering for clean AC power.
- **Synchronized Sinewave*.** Eliminates voltage reversal to input of your equipment.
- **1 Millisecond Transfer Time*.** Includes detection and transfer so your machine never notices loss of electrical power.
- **Two Audible Alarm Levels.** Notifies user of battery usage and two minute warning.
- **LED Display.** Informs user of operation mode, power utilized on AC, plus "On Battery" and battery power status.
- **Alarm Silencer.** Enables user to silence alarm for quiet continued use during battery operation.
- **Optional Signal Port.** Enables UPS to notify computer of loss of AC power to allow computer to back-up or shut down. *250 watt and 500 watt units offer 4 msec transfer time. PWM wave form.

SOFTWARE SPECTACULAR! SENSATIONAL SAVINGS!

MS-DOS® BUSINESS SOFTWARE

Allways	\$ 92
Borland Quattro (1-2-3 Clone)	169
Borland Sprint: The Work Processor	138
DAC Easy Accounting (all version 3)	61
DAC Easy Bonus Pack	123
DAC Easy Payroll	61
dBase III Plus	439
dBase IV	499
Desqview	79
Desqview 386	116
Formtool	55
Framework III	399
Generic Cadd, Level 1	28
Generic Cadd, Level 2	55
Harvard Graphics	299
Lotus 1-2-3 2.01	319
Multiplan	134
Pagemaker 3.0	529
Peachtree Complete System II	174
pfs: First Choice	99
pfs: First Publisher	83
pfs: Professional File with Report	
pfs: Professional Plan	62
pfs: Professional Write	125
Printshop Bundle	37
Printshop Companion	31
Publish It!	122
Q & A	229

Quicken	\$ 31
Rightwriter	52
Ventura Publisher 2.0	529
WordPerfect 5.0	255
WordStar Pro Release 5	248

OTHER MS-DOS SOFTWARE

Chess Master 2100	\$32
F-19 Stealth Fighter	43
Kings Quest I, II, III or IV	31
Leisure Suit Larry	26
Leisure Suit Larry II	30
Managing Your Money	129
Mavis Beacon Teaches Typing	33
Math Blaster Plus	28
Microsoft Flight Simulator	37
Reader Rabbit	26
Test Drive	22
Typing Tutor IV	31
Where in Europe is Carmen San Diego?	28
Where in U.S.A. is Carmen San Diego?	28
Where in World is Carmen San Diego?	25

MS-DOS LANGUAGES/UTILITIES

AutoSketch	\$ 53
Borland Sidekick Plus	138
Borland Turbo BASIC	69
Borland Turbo C	104
Borland Turbo PASCAL with 8087/BCD	103
Carbon Copy + (need two copies)	119
Copy II PC	21

Copy II PC Option Board Deluxe	\$116
Fastback Plus	115
Grammatik III	54
Laplank Plus	84
Microsoft Macro Assembler 5.1	99
Microsoft Quick BASIC Compiler	67
Microsoft Quick "C" Compiler	67
Microsoft Windows 286	67
Microsoft Windows 386	133
Norton Utilities 4.5 Advanced	79
PC Tools Deluxe 5.0	45
Procomm Plus	46
Sideways	42
X Tree Pro	69

BOOKS

Take advantage of our volume discounts and save a bundle! Buy any 3 books and earn an additional \$3 discount. Buy 4 and deduct \$4. Buy 5, deduct \$5, etc.

Using 1-2-3, Special Edition	\$19
dBase III Plus Handbook	17
dBase IV Handbook	16
Managing Your Hard Disk	16
MS-DOS Users Guide 3rd Edition	17
Running MS-DOS	17
Using AutoCad	21
Using Managing Your Money	15
Using Paradox	17
Using Q & A	16
Using WordPerfect 4.2	16
Using WordPerfect 5	19

Clone smolD®

Reg. U.S. Pat. Off.



ORDER TOLL FREE!

Mon.- Fri. 9-7; Sat. 10-3

Call from anywhere in the lower 48 states and Hawaii.

1-800-527-0347



AD L7

HIGH QUALITY...LOW PRICE!

We've Built Our Reputation on This Premise for Almost a Full Decade.

Clone 286 With
LOW PRICE

\$1299

Complete System!

10MHz, 30MB HARD DRIVE, MONOCHROME MONITOR

Clone 286 With
MEDIUM SPEED

\$1919

12MHz, 40MB HARD DRIVE, EGA MONITOR

Clone 286 With
HIGH SPEED

\$2379

16MHz, 65MB HARD DRIVE, VGA MONITOR

VGA Color!

Standard Features of All Clone 286 Computers:

- 80287 Socket.
- 640K RAM.
- 1.2MB or 360KB Floppy Drive (Your Choice).
- 2 Floppy/2 Hard Disk Controller, 1:1 interleave.
- Clock Calendar with Battery Backup.
- System Reset Switch Located on the Front Panel.
- 1.44MB Floppy Capability.
- Enhanced 101-key Keyboard.
- Keyboard Lock.
- Fully Expandable.
- One Year Parts and Labor Warranty.
- Novell Compatible.
- 1 Parallel, 1 Serial, 1 Joystick Port.
- PC-Write - QModem - ExpressCalc AutoMenu - HomeBase - Money Master - Findex - Clone Utilities.
- FCC Certified.

With MS-DOS® 3.3 or 4.01 and GWBASIC \$79 or \$99 Extra

GUARANTEED One year parts and labor. 30 day money back guarantee (except software).

SERVING YOU SINCE 1980

MEMBER DIRECT MARKETING ASSOCIATION MEMBER MMC MICRO COMPUTER MARKETING COUNCIL



CLONE VALUE CHART

		MONOCHROME		COLOR		
		Hercules	VGA	CGA	EGA	VGA/MultiFrequency
10MHz 0 WAIT	30MB/1:1 RLL 65ms	\$1299	\$1579	\$1459	\$1719	\$1879
	40MB/1:1 MFM 40ms	1399	1679	1559	1819	1979
	65MB/1:1 RLL 40ms	1499	1779	1659	1919	2079
	122MB/1:1 RLL 28ms	1799	2079	1959	2219	2379
12MHz 0 WAIT	30MB/1:1 RLL 65ms	\$1399	\$1679	\$1559	\$1819	\$1979
	40MB/1:1 MFM 40ms	1499	1779	1659	1919	2079
	65MB/1:1 RLL 40ms	1599	1879	1759	2019	2179
	122MB/1:1 RLL 28ms	1899	2179	2059	2319	2479
16MHz 0 WAIT	30MB/1:1 RLL 65ms	\$1599	\$1879	\$1759	\$2019	\$2179
	40MB/1:1 MFM 40ms	1699	1979	1859	2119	2279
	65MB/1:1 RLL 40ms	1799	2079	1959	2219	2379
	122MB/1:1 RLL 28ms	2099	2379	2259	2519	2679

OPTIONAL EQUIPMENT FOR CLONE COMPUTERS

MODEMS & RODENTS

Logimouse with Software, Bus or Serial..... \$ 75
Logimouse with First Publisher..... 108
Microsoft Mouse with software, Bus or Serial..... 108
Microsoft Mouse with Windows 286..... 149
Mach III Joystick, each..... 32
Joystick, each..... 24
Internal 300/1200 w/software..... 59
Internal 300/1200/2400..... 106
Hi-Res Logimouse with software, Bus..... 94
Hi-Res Logimouse with Publisher, C.A.D.D., and Paint..... 177
Flight Stick..... 50

FLOPPY DRIVES

360K 5 1/4" TEAC FD55B..... \$ 79
1.2MB 5 1/4" TEAC FD55G..... 109
720K 3 1/2" TEAC FD35F..... 99
1.44MB 3 1/2" TEAC FD235HF..... 109

ADD-ONS & ACCESSORIES

TTL Hercules graphics with parallel port..... \$ 49
Color Graphics Adapter 640x200 w/par. port..... 49
EGA card..... 159
VGA card..... 259
All 8087 and 80287's in stock. Call for price!
Centronics/Centronics molded cable 10'..... 20
Printer Switch Box, 2-pos., Centronics or DB-25..... 39
Printer Switch Box, 4-pos., Centronics or DB-25..... 49

Vertical CPU stand (Add \$9 for wheels)..... \$ 24
AST Rampage 2MB EEMS memory board for AT with 512K..... 439
Masterpiece Plus. Power Dir. with Modem Protect..... 119
The Complete Fax 9600..... 449
The Complete Fax Board..... 273
The Complete Answering Machine Board..... 227
The Complete Hand Scanner(400 DP)..... 162
The Complete Half-Page Scanner..... 195

PRINTERS

Star NX-1000 144cps NLQ..... \$179*
Star NX-1000 Rainbow (above w/color)..... 229*
Star NX-15 120/30cps NLQ (wide)..... 309*
Star ND-15 180/45cps..... 389*
Star NR-10 240/60cps NLQ..... 349*
Star NR-15 same but wide..... 449*
Star NB-15 300/100cps NLQ..... 719*
Star NB24-10 216/72cps LQ..... 449*
Star NB24-15 same but wide..... 579*
Star NX-2400 170/57cps LQ, 24 pin..... 319*
Panasonic KX-PI124 80/192cps, 24 pin..... 339*
Panasonic KX-P1091i, 80 col/120cps..... 189*
Panasonic KX-P1080i, 80 col/144cps..... 169*
Panasonic KX-P1092i, 80 col/240cps..... 329*
10' Printer Cable..... 12*

*with purchase of our computer.

A wide variety of other printers available!

NO ORPHANED CUSTOMERS

We have been supplying customers with high quality hardware and software since 1980. Sound engineering, high performance, quality construction, outstanding warranties and a reputation for doing the right thing have been our way of doing business since Day One. As the manufacturer of Clone Computers, we stand behind each computer sold with a 100% commitment to our customer's satisfaction. Price, Performance, Value...Clone is the clear choice for serious computer users. Remember...YOUR BEST FRIEND MAY BE A CLONE.

Buy with Confidence! Our Guarantee Removes All the Risk from Your Buying Decision!

The Clone Guarantee is simple and straightforward. You have 30 days after receipt of your Clone to see if you and it are going to be compatible. If you are not satisfied with your Clone for any reason within that time, you may return it for a full refund, less shipping charges. Just don't write in the manuals and damage or lose anything that was in the original container, which also must be returned. You can void your warranty by failing to exercise normal care when hooking up or operating your Clone. Complete warranty details are available on request.



TURBO CLONE

AT Style Keyboard **\$749** Save Now!

Standard Features:

- 8088 @ 4.77 - 10MHz Turbo-speed
- Mainboard.
- 640K RAM standard.
- 8087 Socket.
- 150 Watt Power Supply.
- 360K Floppy Drive with Disk Controller.
- Hercules® Compatible Video Card.
- Hi-Resolution TTL Monitor (choose green or amber).
- 2-Parallel Printer Ports.
- 1-Serial Port (2nd Optional at \$29).
- Game-Joystick Port.
- Clock/Calendar with battery backup.
- 8 Slots.
- Fully Expandable.
- Mom's ROM BIOS.
- PC-Write - QModem - ExpressCalc - HomeBase - Money Master - Findex - Clone Utilities - AutoMenu.

- FCC Class B Certified.
- Keyboard Lock.
- System Hardware Reset Switch on Front Panel.

- LED's for Power, Turbo and Hard Disk Access.
- One Year Parts and Labor Warranty.



CLONE COMPUTERS • 2544 W. Commerce St. • Box 223957
Dallas, Texas 75222-3957 • Telex: 882761 • Fax: 214-634-8303

For information or technical assistance call 214-637-5400

©1989 by Clone Computers. All rights reserved. Prices and specifications subject to change without notice. All prices are in U.S. Dollars. Payments must be in U.S. funds drawn on a U.S. bank.

Clone smolD

Reg. U.S. Pat. Off.

Circle 24 on Reader Service Card

VOICE MASTER KEY[®]
VOICE RECOGNITION SYSTEM
 FOR PC/COMPATIBLES & TANDY 1000 SL/TL

A FULL FEATURED VOICE I/O SYSTEM

GIVE A NEW DIMENSION TO PERSONAL COMPUTING. . . The amazing **Voice Master Key System** adds voice recognition to just about any program or application. Voice command up to 256 keyboard macros from within CAD, desktop publishing, word processing, spread sheet, or game programs. Fully TSR and occupies less than 64K. Instant response time and high recognition accuracy. Voice recognition tool-box utilities are included. A **genuine productivity enhancer!**

SPEECH RECORDING SOFTWARE. . . Digitally record your own speech, sound, or music to put into your own software programs. Software provides sampling rate variations, graphics-based editing, and data compression utilities. Create software sound files or send voice memos through LANs. A **complete, superior speech and sound development tool.**

SOFTWARE CONVERSION CODES. . . The **Voice Master Key System** operates a growing list of third party talking software titles using synthesized phonetics (text-to-speech) or digitized PCM, ADPCM, and CVSDM encoded sound files. **Voice Master Key System does it all!**

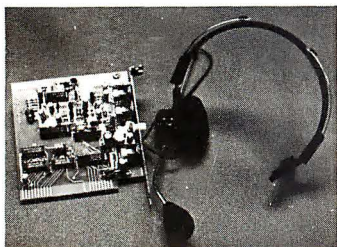

EVERYTHING INCLUDED. . . **Voice Master Key System** consists of a plug-in card, durable lightweight microphone headset, software, and manual. Card fits any available slot. External ports consist of mic inputs and volume controlled output sockets. **High quality throughout, easy and fun to use.**

ONLY \$149.95 COMPLETE

ONLY \$89.95 FOR TANDY 1000 SL/TL MODELS—
 SOFTWARE PACKAGE ONLY.
 Requires Tandy Brand Electret microphone.

ORDER HOTLINE: (503) 342-1271
 Monday-Friday, 8AM to 5PM Pacific Time

Visa/MasterCard, company checks, money orders, CODs (with prior approval) accepted. Personal checks subject to 3 week shipping delay. Specify computer type and disk format (3 1/2" or 5 1/4") when ordering. Add \$5 shipping charge for delivery in USA and Canada. Foreign inquiries contact Covox for C & F quotes. **30DAYMONEY BACK GUARANTEE IF NOT COMPLETELY SATISFIED. ONE YEAR WARRANTY ON HARDWARE.**

CALL OR WRITE FOR FREE PRODUCT CATALOG



COVOX INC. 675-D Conger St.
 Eugene, Oregon 97402 U.S.A.
 TEL: 503-342-1271 • FAX: 503-342-1283

Presto!
A Link to Mainframe Graphics

Find out how our whole family of EMU-TEK graphics terminal emulation software makes good sense for the work you do. Call today for more information.

FTG DATA SYSTEMS

(714) 995-3900
 (800) 962-3900 (800) 972-3900 (Calif.)
 10801 Dale St., Suite M-2
 Stanton, CA 90680

Circle 105 on Reader Service Card

FREE CATALOG
RS-232C INTERFACE & MONITORING EQUIPMENT CATALOG

WRITE OR CALL for YOUR FREE COMPREHENSIVE B & B ELECTRONICS CATALOG TODAY! Pages and pages of photographs and illustrated, descriptive text for B&B's complete line of RS-232 converters, RS-422 converters, current loop converters, adapters, break-out boxes, data switches, data splitters, short haul modems, surge protectors, and much, much more. Most products meet FCC Part 15.1. Your RS-232 needs for quality, service and competitive prices will be more than met by B&B ELECTRONICS. **Manufacturer to you, no middleman!** Money-back guarantee! Same-day shipment! One-year warranty on products! Technical support is available.

Order direct from manufacturer TODAY & SAVE!

Write For Your FREE Catalog Today!
B & B electronics
 MANUFACTURING COMPANY
 4002D Baker Road, P.O. Box 1040 • Ottawa, IL 61350
 Phone: 815-434-0846

Circle 321 on Reader Service Card

LAN-MARK

THE MOST AFFORDABLE AND RELIABLE NETWORK

- Connects up to 64 PCs, ATs, and PS2/30s.
- Saves you enough time to worth your money.
- High speed hardware controlled network, 25 times faster than software links.
- Snap installation, just plug and go.
- No tweaking or adjustments needed.
- **Absolutely, positively guaranteed. Try it for 30 days. Full money back if you are not 100% satisfied.**

Only \$199 per station. 3-Station Pak: \$549.

LAN-MARK Systems, an Advin Company
 1050L East Duane, Sunnyvale, CA 94086
 (408) 243-7000 • Fax (408) 736-2503

Circle 154 on Reader Service Card

8051 FAMILY EMULATORS
 See EEM '88/'89

For info call:

Austria	02 22 38 76 380
Australia	02 654 1873
Benelux	+31 1858-16133
Denmark	02 65 81 11
France	01 69 412 801
Great Britain	01 464 2586
Israel	03 484832
Italy	011 7710010
Korea	02 784 7841
New Zealand	09 392464
Portugal	01 83 56 70
Scandinavia	+46 40922425
Spain	93 217 2340
Switzerland	01 740 41 05
West Germany	08 131 16 87

NOHAU CORPORATION 51 E. Campbell Ave.,
 Campbell, CA 95008
 (408) 866-1820

Circle 198 on Reader Service Card

EPSON[®]

Now you can order **EPSON discontinued or hard-to-find accessories and supplies.**

To order or for a **FREE Information Package, call:**
1-800-873-7766
 and ask for Operator 40

Epson Accessories, Inc.
 19750 So. Vermont Ave.
 Torrance, CA 90502-9962

When you've got an Epson, you've got a lot of company.™

A-3

Circle 92 on Reader Service Card

EPROM PROGRAMMER CROSS ASSEMBLERS

MODEL SX151

RS232C OR STAND ALONE (all models). Communication protocol: XMODEM, HEX, and BIN. Programs: EEPROMS, 2716 - 27512 and CMOS. Programs (w/adaptor): 25Xx, 27101 (and above), 68701, 68705, 68764/6, 8741/2, 8744, 8748/9, 8751/2, 8755, 87252, and CMOS. More available soon. **Model SX151 \$214** (assembled with case). Other models are available from \$49 (kit).

Cross assemblers by PseudoCode for IBM-PCs, \$50. 280, 1802, 6502, 68001/2/3/5/8/9/11, 68000/8/10, 8048/9, 8051/2, 8080/5, 8096, and more soon. Simulators and disassemblers also available.

KORE, Inc.
 6910 Patterson S.E.
 Caledonia, MI 49316
 (616) 791-9333

\$5 for shipping (USA), plus \$3.00 COD.

Circle 147 on Reader Service Card

TurboFlow \$69

Flowchart drawing for IBM PC/XT/AT/PS2

\$89 with Logitech mouse!

- Pop-up icon menus
- Variable size symbols
- Paper size to 34" x 44"
- Hercules mono, CGA, EGA
- HP-GL, DM/PL, SweetP Plotters
- Automatic PANNing to scan drawing quickly
- IBM/EPSON, NEC, OKIDATA, HP LaserJet

Daytron Electronics Inc.
610 S. Sherman #104, Richardson, Tx 75081
Add.s&h (\$4 USA, \$15 foreign), Texas residents add 8% sales tax
for technical information call 214-669-2137

Order Today! 1-800-882-5822

Money-back guarantee

BUY QUALITY FOR LESS! MAXELL

5 1/4" DS/DD 59¢
3 1/2" DS/DD 1.09

LIFETIME WARRANTY
Price based on quantity of 300 in bulk includes Tyvek sleeves and label kits.

800-222-0490
In NJ 201-462-7628
FAX 201-462-5658

• 24 Hour Shipment •
MEGAsoft
P.O. Box 710, Freehold, NJ 07728

Circle 173 on Reader Service Card

IBM DISKETTES

5.25DS	6023450	14.60
5.25 HD	6109660	32.50
3.50DS	6404107	23.95
3.50 HD	6404078	45.95
2 D-1024	1669045	33.95

RIBBONS

PROPRINTER	(6328829)	5.60
PROPRINTER XL	(1040150)	7.99
PROPRINTER X24	(1040475)	8.10
PROPRINTER XL24	(1040414)	11.90
PROPRINTER II	(6328829)	5.60
MONO PRINTER	(1040440)	12.95
QUIETWRITER	(1299790)	9.45
QUIETWRITER III	(1299933)	13.95
DISPLAYWRITER	(1299463)	8.95

"Old Reliable" Delaware 1-800-451-1849
P.O. BOX 10247, WILMINGTON, DE. 19850
the Diskette Connection Oklahoma 1-800-654-4058
P.O. BOX 1674, BETHANY, OK. 73008
Nevada 1-800-621-6221
P.O. BOX 12396, LAS VEGAS, NV. 89112
TELEX 4933362 FAX (405) 495-4598

9-Track Tape Subsystem for the IBM PC/XT/AT

Now you can exchange data files between your IBM PC and any mainframe or mini-computer using IBM compatible 1600 or 6250 BPI 9-Track tape. System can also be used for disk backup. Transfer rate is up to 4 megabytes per minute on PCs and compatibles. Subsystems include 7" or 10 1/2" streaming tape drive, tape coupler card and DOS compatible software. For more information, call us today!

QUALSTAR®

9621 Irontdale Ave., Chatsworth, CA 91311
Telephone: (818) 882-5822

Circle 232 on Reader Service Card

SABINA

MasterCard VISA

SAME DAY SHIPMENT

D - RAMS

41256 - 06	\$12.25
41256 - 08	\$11.50
41256 - 10	\$10.00
41256 - 12	\$9.50
41256 - 15	\$9.00
1mg x 1 - 10	\$22.00
1mg x 1 - 08	\$28.50

MATH CO-PROCESSOR

8087	\$96.00
8087 - 01	\$165.00
8087 - 02	\$127.00
80287 - 06	\$143.00
80287 - 08	\$200.00
80287 - 10	\$230.00
80387 - 16	\$320.00
80387 - 20	\$410.00
80387 - 25	\$510.00

CALL FOR LOWEST PRICES
1-800-2-SABINA

SABINA INTERNATIONAL, INC.
657 Brea Canyon Road Suite #4
Walnut, California 91789
(714)594-6336 • FAX (714)595-4008
PRICES SUBJECT TO CHANGE WITHOUT NOTICE

Circle 249 on Reader Service Card

HARD DRIVE SALE SEAGATE

ST- 225	\$ 255.00
with controller and cable	
ST- 238	\$ 265.00
with controller and cable	
ST- 251	\$ 325.00
ST- 251-1	\$ 420.00
ST- 125	\$ 289.00
with controller and cable	
ST- 138	\$ 359.00
with controller and cable	

A.N. Wholesale & Retail, Inc.
1320 South Dixie Hwy. Suite 256
Miami, Fla 33146

Phone: (305) 284-0827
Fax: (305) 284-0831

Circle 34 on Reader Service Card

AMX 68000

KADAK's engineers bring years of practical real-time experience to over 600 installations world-wide.

This real time MULTITASKING KERNEL simplifies real life product development

- No royalties
- Full source code included
- C interface
- Preemptive scheduler
- Inter-task messages
- Terminal Handler
- Dynamic memory allocation
- Event Manager
- Semaphore Manager
- Resource Manager
- Buffer Manager

AMX 68000 operates on any 68000/10/20 system

Manual only	\$75 US	KADAK Products Ltd.
AMX 68000	\$1500 US	

205 - 1847 W Broadway
Vancouver, B.C. Canada V6J 1Y5
Telex: 04-55670
Fax: (604) 734-8114
Also available for 6800, 280, 8086/186/286
Telephone: (604) 734-2796

Circle 144 on Reader Service Card

Dysan

	2.4 BOX	5.9 BOX	10+ BOX
5 1/4" DS	7 ²⁵	7 ⁰⁰	6 ⁸⁵
5 1/4" HD	11 ⁴⁵	11 ²⁵	11 ⁰⁰
3 1/2" DS	13 ²⁵	12 ⁹⁵	12 ⁷⁵
3 1/2" HD	32 ⁷⁵	32 ²⁵	31 ⁷⁵

"Old Reliable" Delaware 1-800-451-1849
P.O. BOX 10247, WILMINGTON, DE. 19850
the Diskette Connection Oklahoma 1-800-654-4058
P.O. BOX 1674, BETHANY, OK. 73008
Nevada 1-800-621-6221
P.O. BOX 12396, LAS VEGAS, NV. 89112
TELEX 4933362 FAX 405-495-4598

Minimum order \$2000 *No Surcharge on Visa MasterCard.* COD orders add \$300 Surface, Shipping UPS add \$300 per 100 for 3 1/2" or 5 1/4", add \$400 per 100 for 8" U.S. Mail delivery add 9%.*Prices subject to change without Notice.*

PROGRAMMERS

PUT ONE UNIT
ON YOUR DESK TODAY!

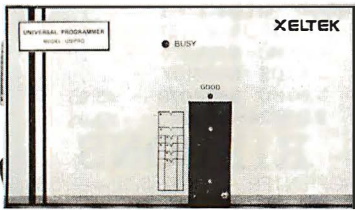

ULTIMATE PROGRAMMING & TESTING
SOLUTION FOR EPROM, PAL, BIPOLAR,
8748 & 8751 SERIES, IC & MEMORY.

UNIPRO --- Only \$545 Complete
Optional 4-socket ADAPTOR
for multiple EPROM programming --- \$99

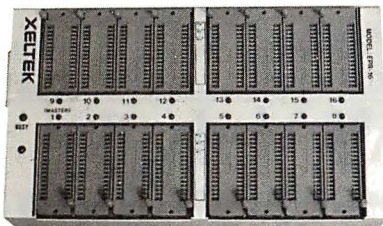

EPROM PROGRAMMERS --- FROM \$160
(1,4,8,16 Socket gang programmers)

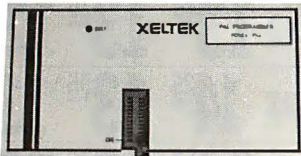

High-speed, dedicated PROGRAMMERS
for PAL, BIPOLAR, 8748 Series, and
8751 Series, and IC & MEMORY
TESTERS are also available.

Ask for PAL DESIGNING S/W
1. PALASM (MMI) 2. PLDesigner (MINC)
3. ORCAD PLD



High Intensity ---from \$59.90
EPROM ERASERS

OEM, DEALER INQUIRY WELCOME

XELTEK

473 SAPENA COURT, UNIT 24
SANTA CLARA, CA 95054

TEL: (408) 727-6995 FAX: (408) 727-6996

ORDER TOLL FREE

1-800-541-1975

VISA, MASTER, AMEX ACCEPTED

PAL™ /PLD SOFTWARE

Sets The Standard



CUPL™ PLD compiler, the most powerful
language for state machine logic design, now
allows OrCAD™ schematic software as the front
end design entry. CUPL supports all PLDs and
carries the most extensive update program.
Available on MS-DOS™, Apollo™, Sun™, VAX™
and most UNIX™ based platforms.

LOGICAL
DEVICES, INC.

1201 N.W. 65th Place
Ft. Lauderdale, FL 33309
305-974-0967
1-800-331-7766

Circle 156 on Reader Service Card
(DEALERS: 157)

IEEE 488 Solutions

- Hardware & software interfaces for PC, AT, 386, PS/2, Macintosh, SUN, HP & DEC
- IEEE converters to SCSI, RS-232, RS-422, modem, Centronics, digital I/O & analog I/O
- IEEE extenders, expanders & buffers
- IEEE drivers for DOS, UNIX®, Lotus 1-2-3, Symphony & Quattro.

Call or send for your
FREE Technical Guide

Demo disks and application notes available

Please
see our
ad on
page 111.

IOtech

(216) 439-4091

Telex 6502820864 • Fax (216) 439-4093
IOtech, Inc. • 25971 Cannon Road
Cleveland, Ohio 44146

Circle 139 on Reader Service Card

IMAGING CARD

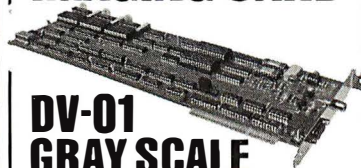

**DV-01
GRAY SCALE
FRAME GRABBER**

Composite video in/out

256 x 240 resolution

Digitize/display at frame speed

256 gray levels in

16 Meg. color palette out

PCI/XT/AT compatible

\$849.00 Complete with software
VISA/MC Demo Disk available

Control Vision

P.O. Box 596, Pittsburg, KS 66762
(316) 231-6647

Circle 70 on Reader Service Card

UNIVERSAL/GANG

PROGRAMMER

made in U.S.A.

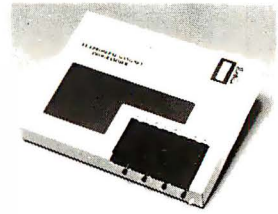

\$595.00
Includes
One Year
Update
and
Warranty

HUSKY™ programs EE/EPROMS, CMOS PLDS,
and Micros. It's your best bet when low cost
and quality are both important.

From the people who make CUPL and ALLPRO.

LOGICAL
DEVICES, INC.

1201 N.W. 65th Place
Ft. Lauderdale, FL 33309
305-974-0967
1-800-331-7766

Circle 158 on Reader Service Card
(DEALERS: 159)

Satellite Communication MICROSAT II Expansion Board

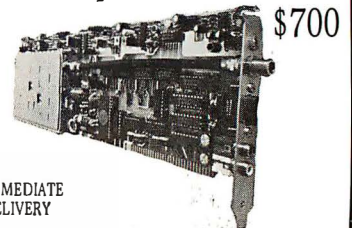

\$700

IMMEDIATE
DELIVERY

- For IBM PC/XT/AT and compatible.
- Satellite data receiver - 9600 baud.
- Satellite bulletin board.
- Satellite video and audio option - Add \$200

PERSONAL SPACE COMMUNICATIONS

707 Johnson Road, Blaine WA 98230
(604)597-6298 TLX 04-508306 FAX (604)597-6214

Circle 216 on Reader Service Card

9-TRACK TAPE SYSTEMS!



OVERLAND DATA IS THE EXPERT when it
comes to connecting your PC to the mainframe
and mini computer world.

- PC/XT/AT/386/PS2/compatibles
- 800, 1600, 3200, 6250 BPI
- Free tutorial on tape systems
- EBCDIC/ASCII conversion
- IBM & ANSI labeled tapes
- DOS, XENIX, UNIX, PICK
- Highest quality customer service
- Stock full range of tape drives
- Network backup and More!

Overland Data Inc.

5620 Kearny Mesa Rd. • San Diego, CA 92111
Tel: (619) 571-5555 • FAX: (619) 571-0982

Circle 202 on Reader Service Card

SAVE \$17



Subscribe to BYTE now and save \$17 off the newsstand price of \$42.00... and \$5.00 off the regular subscription rate of \$29.95. You'll also receive our special IBM PC issue as part of your subscription.

- USA \$24.95/1 year Canada \$26.95 U.S./1 year
- Bill me
- Payment enclosed
- Charge to my VISA MasterCard

Account # _____
Expires _____
Signature _____

This is a renewal order.

Name _____
(Please Print)

Company _____
Address _____
City/State _____
Country _____ Code _____

For direct ordering, call toll free 1 800 257-9402 weekdays
9:00 AM-5:00 PM EST. In New Jersey, call 1 609 426-5535.

Please allow 6-8 weeks for processing your subscription.

IBJ5575



SAVE \$17



Subscribe to BYTE now and save \$17 off the newsstand price of \$42.00... and \$5.00 off the regular subscription rate of \$29.95. You'll also receive our special IBM PC issue as part of your subscription.

- USA \$24.95/1 year Canada \$26.95 U.S./1 year
- Bill me
- Payment enclosed
- Charge to my VISA MasterCard

Account # _____
Expires _____
Signature _____

This is a renewal order.

Name _____
(Please Print)

Company _____
Address _____
City/State _____
Country _____ Code _____

For direct ordering, call toll free 1 800 257-9402 weekdays
9:00 AM-5:00 PM EST. In New Jersey, call 1 609 426-5535.

Please allow 6-8 weeks for processing your subscription.

IBJ5575





NO POSTAGE
NECESSARY
IF MAILED
IN THE
UNITED STATES

BUSINESS REPLY MAIL
FIRST CLASS MAIL PERMIT NO. 42 HIGHTSTOWN, NJ

POSTAGE WILL BE PAID BY ADDRESSEE

BYTE

Subscription Department
P.O. Box 558
Hightstown, N.J. 08520-9409

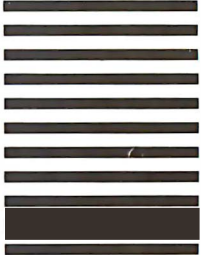

NO POSTAGE
NECESSARY
IF MAILED
IN THE
UNITED STATES

BUSINESS REPLY MAIL
FIRST CLASS MAIL PERMIT NO. 42 HIGHTSTOWN, NJ

POSTAGE WILL BE PAID BY ADDRESSEE

BYTE

Subscription Department
P.O. Box 558
Hightstown, N.J. 08520-9409



REAL WORLD I/O For PC/XT/ATs

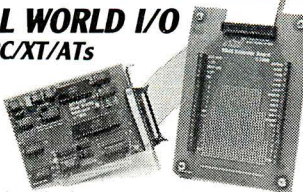

- DC24 • 24 line digital I/O; 10 MHz 8255. \$95
- AD500 • 8 channel 12-bit (plus sign) integrating A/D; prog gains of 1, 10 & 100; 7 digital I/O lines. \$239
- AD100 • Single channel version of AD500; 10 digital I/O lines. Same programmable gains. 700 meg input Z. \$149
- AD1000 • 8 channel 12-bit A/D; 25 uS. sample & hold; 3.5 MHz timer/counters; 24 digital I/O lines. \$295
- ADA300 • 8 channel 8-bit 25 uS A/D; single D/A sample & hold; 24 digital I/O lines. \$239
- AD200 • 4 channel 12-bit 125 uS A/D; 3.5 MHz timer/counters; 24 digital I/O lines. \$239
- DA600 • Fast settling dual bipolar D/A. \$179
- PD200 • Prototype board w/ address decoder; manual. \$99

All boards include BASIC, Pascal, C, and Fortb drivers. 30 day return; 1 year warranty. Call for "Real World Interfacing" application notes.

Real Time Devices, Inc.
P.O. Box 906 State College, PA 16804
(814) 234-8087

LOW-LOW-LOW

- Laserjet Printer Series II \$1650
- Scanjet Scanner + interface kit \$1355

IBM COMPAG Apple ACER
EVEREX AST & other

XT/AT Compatibles & 386 Computers
CALL for LOW PRICES

Gov't, Corporate, Schools, Dealers,
& Export INQUIRIES WELCOME.

SURAH inc.

44862 Osgood Road, FREMONT, CA 94539
PH: (415) 651-5101 FAX: (415) 651-5241
1-800-543-1001
VISA, Master Card accepted. w/sc



E(E)PROM, MICRO & MEMORY CARD PROGRAMMER... \$345 - \$595

- No personality modules for E(E)PROMs & Intel Micros.
- All 24/28/32 pin EPROMs to 1 Mbit (upgradable to 32MB)
- 8741,-2,-4,-8,-8H,-9,-9H,-51,-C51,-52,-55, 9761. EEPROMS.
- Memory Cards: Seiko/Epson, GI. Flash EPROMs. On-board Programming capability. Easy F/W upgrades. Modular design.
- Stand-alone E(E)PROM & Memory Card Duplication / Verify.
- User friendly menu - driven driver for IBM-PC & Macintosh.
- Autobaud RS232 to any computer. Hex/Binary/Intel/Motorola.
- Built-in Eraser/Timer option (\$50). Gang-Memory ready.
- Direct technical support. Full 1 year warranty.

Call today for datasheets!



B&C MICROSYSTEMS INC.

355 West Olive Ave, Sunnyvale, CA 94086
(408)730-5511 FAX: (408)730-5521 TLX: 984185

Circle 246 on Reader Service Card

Circle 270 on Reader Service Card

MARYMAC®

13th year of Discounting Computers, FAX & Cellular Phones

Radio Shack® SCO Tandy®

We will meet or beat...
GUARANTEED LOWEST PRICES

MARYMAC INDUSTRIES INC.
22511 Katy Fwy.
Katy (Houston), TX 77450
1-713-392-0747 FAX (713) 574-4567
Toll Free 800-231-3680

Circle 164 on Reader Service Card

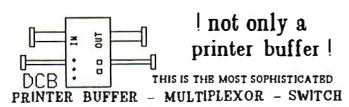

WITH TWO SEPARATE INPUTS (SERIAL AND PARALLEL) AND TWO SEPARATE OUTPUTS (SERIAL AND PARALLEL) CAN BE USED LIKE STANDARD BUFFER... WITH ANY INPUT TO ANY OUTPUT... BUT ALSO YOU CAN CONNECT 2 COMPUTERS TO 1 PRINTER, OR 1 COMPUTER TO 2 PRINTERS, OR 2 COMPUTERS AND 2 PRINTERS AND MORE = 1 COMPUTER TO 3 PRINTERS OR 3 COMPUTERS TO 1 PRINTER
HIGH CAPACITY - 64 KB TO 256 KB AND - 256 KB TO 1 MB (MODELS A AND B) PAUSE, COPY AND RESET FUNCTIONS SERIAL PORTS WITH 7 OR 8 BITS WORD LENGTH, 1 OR 2 STOP BIT, PARITY, XON/XOFF, DTR, RTS

DCB-A-64K \$ 195 DCB-B-256K \$ 255 (*)
(*) Power supply and parallel cables are included.

ALSO, WE HAVE THE MOST COMPLETE DATA CONVERTER UNIT. CONVERTS RS232 SERIAL TO CENTRONICS PARALLEL OR VICE VERSA, JUST BY MOVING JUMPERS BAUD RATE AND PROTOCOL FULLY PROGRAMMABLE FROM 160 TO 19200 BAUDS INCLUDES: DTR, RTS, XON/XOFF, PARITY, etc

DCU \$ 80 (**)

(**) Power supply and cables NOT included

serial \leftrightarrow parallel bi-directional converter

INTECTRA Inc. - Dept 232
2029 TERMINAL BLVD
MOUNTAIN VIEW - CA - 94043
(415) 967-8818 TX 345545

LOW COST INTERFACE CARDS FOR PC/XT/AT

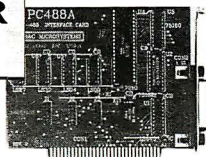

PC485D \$95

[RS 485/422 INTERFACE]

- Meets the EIA RS-485 standard for multipoint bus transmission and the EIA RS-422A standard.
- Can be configured as COM1 or COM2.
- Line terminators are jumper selectable.
- High speed differential drivers allow fast data transfer over long cables (over 4,000 ft). Max. baud rate 56KB/115KB.
- Tri-state line drivers permit implementation of LANs.
- Two wire (half duplex) operation. DB9 or phone jack.
- Sample communication software available. (\$50)

PC488A \$145

[IEEE - 488 INTERFACE]

- Includes INSTALLABLE DOS DEVICE DRIVERS and software support for BASIC.
- Optional language support for C, PASCAL, FORTRAN and ASSEMBLY - \$50
- Selectable base I/O address, IRQ and DMA.
- CONTROLLER / TALKER / LISTENER capability.
- Customer support via dedicated 24 hours B&C Microsystems BULLETIN BOARD.
- Compatible with most IEEE-488 Software Packages for the IBM-PC (e.g. ASYSTANT GPIB, Lotus Measure, etc.).
- Hardware compatible with NI. GPIB - PCIIA.

PC488B \$345

[IEEE - 488 CARD WITH]
[BUILT-IN BUS ANALYZER]

- GPBASIC package complements IBM/Microsoft BASIC interpreter and compiler to create a programming environment similar to HP desktop computers.
- Additional libraries of over 20 high level 488 dedicated functions for C, Pascal or Fortran available (\$50 ea.).
- Powerful menu-driven bus analyzer, which can run in the foreground or in the background while 488 programs or commands are executed, features program stepping, break points and real time bus data capture (4k circular buffer).
- Instant toggling between foreground and Analyzer screen.
- Dipswitch selectable Base Address, IRQ, DMA.
- Talker/Listener/Controller capability. Based on TMS-991.
- NEC-7210 based version (NI PCII/IIA compatible) - \$ 445

MC/VISA/AMEX

Call today for datasheets!



B&C MICROSYSTEMS INC.

355 West Olive Ave, Sunnyvale, CA 94086
(408)730-5511 FAX: (408)730-5521 TLX: 984185

Circle 51 on Reader Service Card

DATA CONVERSION SYSTEMS

9-Track Tape for your PC, AT, PS/2, MAC, Sun

Read/write data from nearly any Mainframe: IBM, DEC, HP, DG, or Honeywell. Runs under MS-DOS, Unix, Xenix, MAC, and SunOS.

8", 5 1/4", 3 1/2"

Diskette converter for your PC/XT/AT

Our diskette conversion system can read/write and format diskettes from IBM Systems 34, 36, 38, AS400, DEC, CMX, CP/M, Displaywriter and many more.



MicroTech Conversion Systems
(415) 324-9114

525 Alma, Palo Alto, CA 94301

Circle 184 on Reader Service Card

NEW! MCPM-3 for MC68HC05 Family

6805/6305 SINGLE CHIP

MICROCOMPUTER DEVELOPMENT SYSTEMS

Each of three products allows the IBM PS2/PC/XT/AT to be used as a complete development system for the Motorola 6805 series single chip microcomputers. MCPM-1 supports the MC68705 family, MCPM-2 supports the MC1468705 family and MCPM-3 supports the MC68HC05 family. Each system is \$495 and includes a programming circuit board or programmer with driver, cross assembler and simulator/debugger software. A system is also available for the HITACHI 63705 ZTAT micro.

THE ENGINEERS COLLABORATIVE
Route 3, Box 8C, Barton, VT 05822
(802) 525-3458 FAX (802) 525-3451

Circle 91 on Reader Service Card



***FREE! DiskFile/60!!**
with purchase of 50 3M diskettes
5 1/4" DS/DD only

DS-DD	Quantity Discounts Available	DS-HD
.69*	5.25" 3M Diskettes	1.19
1.45	3.50" 3M Diskettes	H D 2MB 3.49
1.89	SS/DD 8.00" 3M Diskettes	DS/2MB 2.15
.39	5.25" 3M Highland Diskette	
DC-2000	15.69	DC-300XLP 19.40
DC-6150 (DC600XTD)	22.83	DC-600A 21.45
3M Mag Tape Std w/seal 2400'		12.50
3M Mag Tape Std w/seal 1200'		9.25



***FREE MICRODEX/25**

DS-DD	Quantity Discounts	DS-HD
.54	5.25" BASF Diskettes	.87
1.29*	3.50" BASF Diskettes	H D 2MB *3.29
.35	5.25" BASF NoLogo Diskettes with Tyvek sleeves, labels & w/p tabs	
.49	5.25" BASF SS/DD/48 TPI Diskettes in BASF plastic library box	

maxell	MD-2D-MP	MD-2HD-MP	MF-2DD	MF-2HD
.65*	1.19*	1.47*	3.79	

*in plastic box or with game *in plastic box *in plastic box

Verbatim DataLife	MD-2D-MP	MD-2HD-MP	MF-2DD	MF-2HD
.65	1.19	1.45	3.49	

SONY	MD-2D-MP	MD-2HD-MP	MF-2DD	MF-2HD
.65	1.29	1.49	3.79	

***FREE!** Microsoft Works®
FREE! 11th Diskette (11 for the price of 10)
*** FREE!** \$17.00 Value Discount Book & Storage Case

DS-DD	Quantity Discounts Available	DS-HD
.65#+	MD2D	MD2HD ... 1.19
1.69#+	MF2DD	MF2HD ... *3.59
Fuji Floppy Disk MD2D in Rainbow Color Pack72		

Nashua	MD-2D	MD-2HD	MF-2	MF-2HD
.49	.84*	1.24	3.15	

*in plastic box rainbow color

COLOR DISKETTES

5.25" DS/DD	5.25" DS/HD	3.50" DS/DD
.39	.84	1.26

All 5.25" color diskettes in Tyvek sleeves, labels & w/p

BULK DISKETTES

5.25" DS/DD	5.25" DS/HD	3.50" DS/DD	3.50 DS/HD
.29	.59	1.05	2.79

All 5.25" diskettes in sleeves, labels & w/p tabs

RIBBONS STORAGE
 — Please call for information —

TERMS: No surcharge on VISA, Mastercard or AMEX. COD only add \$3.00. Prepaid orders deduct 2% cash discount. PO's accepted from recognized institutions and corporations on Net 30. Bank draft, T/T or L/C acceptable.
Shipping: \$4/100 or fewer disks. Reduced shipping charges on larger quantities. Price quoted for case (100 disks) quantities less than a case add 5% (Min order \$25.00)

WE BEAT ANY PRICE!
 Toll Free Order Line: **1-800-523-9681**
 Information Line: **1-801-255-0080**
TLX-9102404712 FAX-801-572-3327

DISKOTECH
 DISKCO TECHNOLOGIES, INC.
 213 Cottage Avenue
 P.O. Box 1339 Sandy, Utah 84091

NEW FASTER EPROM PROGRAMMER

• Programs 2764 in 8 sec.
• Reads, programs, copies over 475 devices from 35 mg's: 2716, 27513, 27011, 68764, 68766, 2804-28256, etc.
• Optional microcontroller heads support 874x and 87C51 series
• Improved design now programs over twice as fast
• Automatically uses the latest algorithm recommended by the manufacturer to ensure reliable data storage
• Connects via RS-232 to any computer: PC, XT, AT, PS/2, Mac, etc
• Supports XMODEM/XMODEM CRC protocols & ASCII file xfers
• Supports Intel, Motorola, hex-space, straight hex and binary files
• Checksums supported • 8 baud rates to 38,400
• 30-day money-back guarantee • Collates 16 & 32-bit data
• Eng'r support team for fast updates • Gold Texool ZIF IC sockt
• One-year warranty (parts and labor) • Same day shipment
• Toll-free technical support • UV erases from \$34.95
• Thousands of satisfied customers attest to the EP-1's great value
• Low price of \$349 includes IBM compatible communications program, user's manual and two free firmware update coupons

CALL TODAY FOR MORE INFO 1-800-225-2102

BP MICROSYSTEMS
 10681 Haddington #190, Houston, TX 77043
 (713)461-9430 FAX (713) 461-7413

Circle 44 on Reader Service Card

Advertise your computer products through **BYTE BITS** (2" x 3" ads)

For more information call Mark Stone at **603-924-6830**

BYTE

One Phoenix Mill Lane
 Peterborough, NH 03458

Circle 48 on Reader Service Card

8051 SIMULATOR
 for the IBM PC/XT/AT **\$99**

The 8051SIM software package assists in the debug of 8051 family programs. A screen oriented, menu command driven program, 8051SIM speeds development by allowing program execution and debug without a target system. A great learning tool as well.

8031DryICE \$199

Dry ICE is a debugger/emulator that supports the development of hardware and software using the 8031 microcontroller. The DryICE provides powerful functions to assist in the integration, debug, and test phase. Hardware connects between your target 8031 IC socket and CRT terminal or PC COM port.

HiTE HiTech Equipment Corporation
 9400 Activity Road
 San Diego, CA 92126
 (619)566-1892

Circle 125 on Reader Service Card

SAVE ON 9 TRACK TAPE SYSTEM FOR IBM PC/XT/AT

• Mainframe to PC Data Transfer
 • High Speed Backup
 • All Software, Complete System
 • Service and Support, easy Installation

call (818) 343-6505 or write to:
Contech Computer Corp.
 P.O. Box 153 Tarzana, Calif. 91356

CONTECH

Circle 67 on Reader Service Card

FRAME GRABBERS

MODEL	RESOLUTION	PRICE with frame grab	PRICE without frame grab
HRT 256-4	256 x 256 x 4	495	NA
HRT 256-8	256 x 256 x 8	795	NA
HRT 512-8	512 x 512 x 8	995	NA
HRT 512-24	512 x 512 x 24	1995	1495

- CALL FOR DIFFERENT MODELS
 - IBM PC/XT/AT COMPATIBLE
 - DIGITALIZE IN REAL TIME
 - COMPOSITE VIDEO IN
 - 24 BIT RGB OUT except model HRT 256-4
 16 level gray scale out
 - SOFTWARE LIBRARY OF IMAGE ANALYSIS ROUTINES
 - FREE SOFTWARE UPGRADES TO REGISTERED OWNERS
 - FULL CREDIT ON UPGRADE PURCHASE IN FIRST YEAR
 RETURN OLD BOARD AND JUST PAY DIFFERENCE

INPUT DEVICES (optional)
 Microsoft Mouse (bus or serial) \$99
 Bit Pad Plus by Summagraphics \$359

HRT HIGH RES TECHNOLOGIES
 P.O. BOX 76
 LEWISTON, N.Y. 14092
 PHONE 416-497-6493 FAX 416-497-1988

Circle 126 on Reader Service Card

Dynamic Electronics

SIMMS
 CALL FOR PRICES

INTEL	DRAMS	SIMMS
8087	64K	256 X 8
80287	256K	X9
80387	4464	1 Meg X 8
80387SX	1 Meg	1 Meg X 9
80C287A		

Phone 714-855-0411
 Fax: 714-855-8504
 23522 COMMERCE CENTER DR. #L
 LAGUNA HILLS, CA 92653, USA

Circle 84 on Reader Service Card

The most important
step you can take
is the first.

call toll free



800-888-9294

#1 JT Fax
The Best Selling
PCF in
America



VECTOR From LACC
Model XT-4.77 MHz / 10 MHz Expandable to 640 KB RAM
8088 Main Board Fully IBM PC/XT Compatible/150 W.P.S./Phoenix Bios/
1 Drive Bios/ 1 Drive 360K w/ controller DTK
\$329.00 w/Mono Chrome \$449.00 w/Color \$599.00
Model AT(286-8 MHz) O'Wall PCAT Compatible/195% Faster than IBM AT200 watt
power supply Multi 1.0, 32 KB Phoenix Bios 640 K Exp/Meg
1.2 Meg Floppy 1.3 60K Floppy \$959.00
w/30 Meg \$1319
w/30 Meg Color Monitor \$1499. Mono Monitor

ACCOUNTING

ACCPAC Easy	\$ 53.
ACCPAC BPI	\$229.
Bedford Accounting	\$139.
DAC Easy Accounting	\$ 53.
DAC Easy Payroll	\$ 53.
In-House Accountant	\$105.
One Write Plus 2.0	\$117.
One Write	
A/R, A/P, Payrc	\$117.
Time Slips	\$ 69.
Time Slips III	\$109.

MONEY MANAGEMENT

Dollars & Sense	
w/Forecast	\$ 92.
Tobias	
Managing your	
Money 4.0	\$114.

PROJECT MANAGEMENT

Harvard Total	
Project Manager II	\$309
Timeline 3.0	\$315
Microsoft Project 4.0	\$287
Superproject Expert	\$395

LANGUAGES

MS Basic Compiler	\$175.	Quick Basic 4.0	\$ 57.
C Compiler (Microsoft)	\$259.	Quick C	\$ 57.
Cobol Compiler		Ryan McFarlan Fortran	\$379.
(Microsoft)	\$512.	Ryan McFarlan Cobol	\$609.
MS Fortran		Turbo Basic	\$ 58.
Compiler 4.0	\$259.	Turbo C	\$ 58.
Latice C Compiler	\$209.	Turbo Pascal 4.0	\$ 58.
Macro		Turbo Pascal	
Assembler (Microsoft)	\$ 86.	Dev Library	\$228.
Pascal Compiler		Turbo Prolog	\$ 89.
(Microsoft)	\$175.		

HARDWARE SPECIALS

Panasonic KXP 1080 II	\$169.00	Everex VGA plus	
NEC Multisync II Monitor	\$549.00	Hayes Smart2400 Baud Modem	\$399.00

NEC

Letter Quality Printer
22 Cps Demo 90 day warranty
Retail \$495. LACC \$179.

IBM COMPATIBLE

CASES
AT \$29.95
XT \$19.95

FAX MACHINES

PanaFax - UF 150	\$1069.00
Murata - M - 1600	\$819.00
Brother Fax 1000	\$1459.00

PANASONIC

Model 3131/3151	\$269/439
KXP 1592/1595/1524	\$399/429
1091/1092/model III	\$199/319
1081 model II	\$169.00
NEC	
2200	\$349.00
5200	\$699.00
3550/8850	\$799/1169
OKIDATA	All Available Call

COMMUNICATION

Hayes 1200 E/1200B w/SW	\$279.00
2400 E	\$432.00
2400 B	\$432.00
Everex	Call
LACC Modem 1200 I w/SW	\$69.00
2400 I w/SW	\$119.00

MONITOR INTERFACES

LACC Fabulous Mono Hercules compatible or color card	Call
Hercules Monof/ Here color	\$289/299
Everex Micro Enhancer	\$129.00
Paradise VGA plus	\$259.00

\$1599

The HP LaserJet Series II Printer.

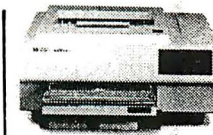

HEWLETT
PACKARD

DESK JET \$699.00



Model 30-8086, 640K, 2 Drives	\$1,295.
Model 50-20Meg - 80286, 1 MB	\$2,295.
Model 60 - 44 Meg	Call
Model 80 - 70 Meg	Call

UTILITIES

1 DIR Plus	\$ 46.	Microsoft Windows 386 \$ 109.	
Brooklyn Bridge	\$ 69.	Norton Commander	\$ 43.
Carousel 2.0	\$ 43.	Norton Editor	\$ 35.
Copy II PC	\$ 18.	Norton Utilities 4.0	\$ 46.
Copywrite	\$ 40.	PC Toos Deluxe	\$ 36.
Corelast	\$ 89.	Printworks for	
Cruise Control	\$ 29.	Do I Matrix	\$ 39.
Direct Access	\$ 48.	Printworks for Laser	\$ 67.
Disk Optimizer 2.0	\$ 38.	Sidekick Plus	\$115.
Disk Technician Plus	\$ 69.	Sideways	\$ 37.
DS, Back-Up Plus	\$ 46.	Smart Noles	\$ 43.
Fastback	\$ 75.	SOZ Plus	\$ 53.
Fastback Plus	\$ 75.	Smart Key	\$ 58.
Keyworks	\$ 53.	Unlock D Plus	\$ 49.
Laplank	\$ 75.	Unlock Masterkey	\$ 95.
Mace Utilities	\$ 47.	XTree	\$ 35.
Microsoft Windows 286 \$ 57.		XTree Professional	\$ 61.

WORD PROCESSORS

Easy Extra	\$ 53.
Grandview	\$159.
Multimate Advantage II	\$259.
PFS: Professional Write	\$102.
Valkyriter3	\$132.
Valkyriter Deluxe Plus	\$ 57.
WEBSTER	
New World Writer	\$ 53.
Pro! Spell Checker	\$ 32.
New World Thesaurus	\$ 37.
Word (Microsoft)	\$185.
Word Perfect 4.2	\$199.
Word Perfect 5.0	\$219.
Word Perfect Executive	\$119.
Word Perfect Library	\$ 59.
Wordstar Pro Pack 5.0	Call
Wordstar 2000 Plus 3.0	Call

HARD DRIVES

Seagate 40 MB 251-1	\$389.00
Plus Hard Card 40	\$659.00
Plus Hard Card 20	\$519.00
Seagate 20 MB 225	\$259.00
Seagate 30 MB 238	\$275.00

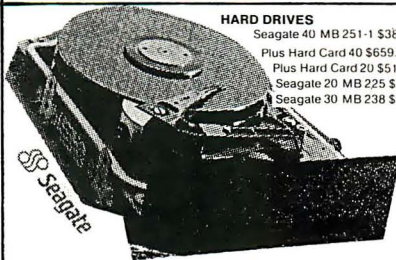

TOSHIBA

LAPTOP

Model 1000	\$ 780.
Model 1200/1200F	\$2250/1395.
Model 3100	\$2995
Model 3200/5100	\$3495/4495.

Also available from LACC (Appie, Compad, Deltagold)
EPSON MC Equity LT- MS Dos 3.2.2 floppy, 20 Meg 640K 4.77 / 10 MHz ECT Call

COMPUTERS (PC MASS EDS CHOICE)

AST Premium 286 - Model 80 - CALL	
Model 120 - CALL	
Model 140 - CALL	
Model 180 - CALL	

All AST Product Available Call

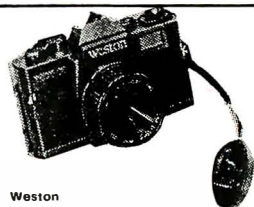

Westcon

Retail \$395.00
Comes w/flash, tripod, camera cases \$49.95

DATA BASE MANAGEMENT

Clipper	\$409.	Paradox 2.0	\$415.
dBase III Plus	\$369.	PFS	
dBase III LAN	\$599.	Professional File	\$119.
DB-XL Diamond	\$107.	O&A	\$185.
Eureka	\$ 99.	O&A Write	\$105.
Genifer	\$188.	R Base For DOS	\$425.
Nutshell	\$72.	Retlex	\$ 88.
Nutshell Plus	\$139.	VP Expert	\$112.
		VP Into	\$ 56.

INTEGRATIVE SOFTWARE

Ability Plus	\$137.	MS Works	\$ 85.
Enable 2.0	\$352.	PFS 1st Choice	\$ 76.
Framework III	\$425.	Smart Software System	\$389.
		Symphony	\$435.

DESKTOP PUBLISHING

Newsmaker II	\$ 39.	PFS First Publisher	\$ 65.
Pagemaker 3.0	\$489.	Ventura Publishing	\$475.



A California Corporation

Open Monday Thru Friday
7 am to 6 pm
Saturday
8 am to 2 pm

LA COMPUTER CORPORATION
A CALIFORNIA CORPORATION

3701 Inglewood Ave. Ste. 161, Redondo Beach, CA 90278-1110

SHIPPING
UPS, US Mail
Fed. Express
Emery
Other

FAX # 213-328-1750

Outside CA.
800-888-9294
Inside CA
213-328-9294

P.O.'s accepted from qualified companies, institutes and schools.

WE ACCEPT:
COD
Wire Transfers



Terminal Emulation

TEK 4105/4010

- Tektronix 4105
- Tektronix 4010/4014
- VT220, VT102
- Picture files
- VGA and EGA support
- High resolution hardcopy

VT220

- VT220, VT102 emulation
- File transfer
- 132 column modes
- Color support
- Hot key

Diversified Computer Systems, Inc.

3775 Iris Avenue, Suite 1B
Boulder, CO 80301 (303) 447-9251
FAX 303-447-1406

Trademarks: VT102, VT220 — DEC; Tektronix — Tektronics Inc.

Circle 81 on Reader Service Card

DATA ACQUISITION

ALL needs! ANY computer!

- PC Software Included
- Serial, Modem, & Bus
- Stand Alone Ability
- Laptop & Handheld
- PC & MAC Cards
- Inexpensive
- OEM & VAR
- RTU's



Call for FREE DEMO DISK!

Specialists in portable and battery backed up as well as PC compatible modular systems.



Call for applications info: (201) 299-1615
P.O. Box 246; Morris Plains, NJ 07950

MEASUREMENT TO GO

ELEXOR

Circle 86 on Reader Service Card



Sure it's insured?

SAFEWARE® Insurance provides full replacement of hardware, media and purchased software. As little as \$39/yr. covers:

- Fire • Theft • Power Surges
- Earthquake • Water Damage • Auto Accident

For information or immediate coverage call:

1-800-848-3469

In Ohio call 1-614-262-0559



SAFEWARE. The Insurance Agency, Inc.

Circle 252 on Reader Service Card

PAL/EPROM PROGRAMMER for PC

VERSION 2 of Software and Hardware \$475

- Programs 20 and 24 pin MML, NS, TL, Alkera, Cypress, Ricoh/Panatec PALs, EPLD (UV erasable), polarity, and RA types.
- Functions Include: read, write, verify, protect, edit, print, and file load and save of program.
- JEDEC files supported.
- 2716-27512 EPROMs.
- Functions include: read, write, verify, blank check, HI/LO split, edit in ASCII, HEX, or Decimal.
- INTEL Hex and Motorola S' Record file support.

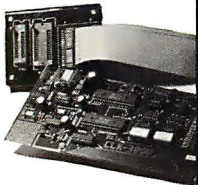

200/100 MHz LOGIC ANALYZER for PC



LA27100

\$1299

LA27200

\$1899

- 24 Channel mode with 4K/channel • 6 Channel mode with 16K/channel
- Internal Rates from 200MHz(LA27200) or 100MHz(LA27100) to 250 Hz
- External Clock from DC to 50 MHz • 16 Level Triggering Sequence
- Threshold Voltage Level at TTL, ECL, or -8V to +14V variable • Data Display as Timing Diagram or State List • Save/Load Data and Setup Info.

(201) 994-6669

Link Computer Graphics, Inc.
4 Sparrow Dr., Livingston, NJ 07039



Circle 155 on Reader Service Card

TWIX COMPUTERIZED CASH REGISTERS



THE TWIX 3000 SERIES OF REGISTERS PROVIDE THE FLEXIBILITY OF A COMPUTER OR TERMINAL WITH THE LOOK AND FEEL OF A CASH REGISTER.

• 3010 "REGISTER HEAD" - REPLACES THE KEYBOARD, MONITOR, AND PRINTER OF ANY IBM XT/AT COMPATIBLE COMPUTER.

• 3040 "REGISTER TERMINAL" - TV 950 EMULATION PLUS DRAWER, MONITOR AND SCANNER CONTROL.

• 3070 "REGISTER COMPUTER" - STANDALONE IBM COMPATIBLE WITH 20 OR 40 MB HARD DISK DRIVES.

ALL MODELS AVAILABLE WITH A VARIETY OF RECEIPT PRINTERS, KEYBOARDS, MONITORS, CASH DRAWERS, BAR CODE SCANNERS AND MAG STRIPE

TWIX INTERNATIONAL CORP.
4401 S. BROADWAY, ENGLEWOOD, CO 80110
(303) 789-5333

Circle 286 on Reader Service Card

ON TARGET ASSOCIATES

Products and Services
for Design and Manufacturing Engineers.

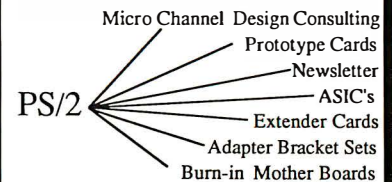

We will move your PC/XT/AT products to the Micro Channel, or create your new design.

CALL: (408) 980-7118
for our Free catalog

ON TARGET
TARGET
TARGET

...the PS/2 leaders.

PS/2 and Micro Channel are trademarks of IBM Corp.

Circle 201 on Reader Service Card

9-TRACK MAG. TAPE SUBSYSTEM* FOR THE IBM PC/XT/AT AND...



For information interchange, backup and archival storage, AK Systems offers a 9-track, IBM format-compatible 1/2" magnetic tape subsystem for the IBM PC, featuring:

- IBM format 1600/3200 and 800 cpi.
- Software for PC-DOS, MS-DOS, XENIX.
- Also for AT&T, DEC, VAX, VME, S-100, RS-232, IEEE 488.

*formerly IBEK Mainstr computer

AKSystems

20741 Manilla St.
Chatsworth, CA 91311
(818) 709-8100
TWX: 910-493-2071

Write, phone or TWX for information.

8051/8052 BASIC COMPILER!

MCS BASIC52™ compatible
Runs on IBM-PC or compatible

\$ 295.00

Call Now! 603-469-3232



Binary Technology, Inc.

Main Street • P.O. Box 67 • Meriden, NH 03770

Circle 17 on Reader Service Card

NEW! VERS. 2.0

BIGMOUTH™

REAL VOICE Digital Recording
for your PC, XT, AT or Compatible

- ◆ VOICE MAIL SYSTEM
- ◆ TELEMARKETING
- Inbound & Outbound
- ◆ SMARTEST ANSWERING MACHINE
- ◆ AUTODIALER—DATABASE
- ◆ VOICEPAD™
- Voice for your Programs
- ◆ PROGRAMMER'S TOOLKIT
- (optional \$79.00)

1/2 card, software, cables, and speaker

MSA \$269.00 + 5 s/h

(415) 652-9600

Talking Technology, Inc.
4383 Piedmont Ave. Suite B
Oakland, CA 94611

Circle 275 on Reader Service Card

WE SELL NOTHING AT RETAIL — CALL (800) 654-7762

CAT™ 8MHZ

BASE SYSTEM

- 256K (Opt. 640K) • 150 Watt Power Supply • AT Style Keyboard & Case
- 4.77 or 8 MHZ Keyboard Selectable • FDC
- 8087 Socket • 360K Floppy Drive • 1 Year Warranty

\$39900

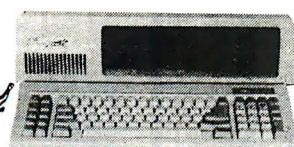

CAT 386 SYSTEM

- 12" Amber Monitor with Graphics Interface Card
- 1.2 Meg Floppy Drive (expandable to 8 Meg)
- 1 Meg of Memory
- Parallel, Serial & Clock
- 70 Meg Hard Drive

20MHz **\$229700**

CAT™ 286-10

BASE SYSTEM

- 512K Exp. to 1 MEG • 200 Watt Power Supply • AT Style Keyboard
- Western Digital Controller • 1.2 Meg Floppy • Legal Bios w/manuals • Systems Documentation • 1 yr war. • Clock/Calc
- 10MHz DTK Motherboard

\$79900

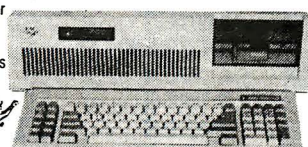

OPTION A
12" Mono Amber Monitor
Graphics Card w/par port
\$51900

OPTION B
640 x 200 Color Monitor
Graphics Card w/par port
\$69600

OPTION C
12" Mono Amber Monitor
Graphics Card w/par port
20 Meg Hard Drive
\$78800

OPTION A AT
12" Mono Amber Monitor
Graphics Card w/par port
\$94900

OPTION B AT
640 x 200 Color Monitor
Graphics Card w/par port
\$109600

OPTION C AT
12" Mono Amber Monitor
Graphics Card w/par port
40 Meg Hard Drive
\$139900

WHOLESALE PRICING WITH RETAIL SERVICE CALL (800) 654-7762

intel COPROCESSORS

If Your PC Uses the Intel	Running at..	Then You Need Intel	MEADS Price
8088	5MHz or less	8087	97 ⁰⁰
8088 or 8086	8MHz or less	8087-2	143 ⁰⁰
8086	10MHz or less	8087-1	209 ⁰⁰
80286	6-8MHz	80287	159 ⁰⁰
80286	8-10MHz	80287-8	229 ⁰⁰
80286	10MHz or more	80287-10	259 ⁰⁰
80386	16MHz	80387-16	379 ⁰⁰
80386	20MHz	80387-20	479 ⁰⁰
80386	25MHz	80387-25	669 ⁰⁰
386SX	16MHz	80387-SX	399 ⁰⁰

ALL KINDS OF RAM UPGRADES

WE BUY EXCESS RAMS PLEASE CALL OR FAX LIST

64K	1 Meg.
4464 100 NS 16 ⁹⁹	1Meg x 1 120 NS 25 ⁰⁰
4464 120 NS 15 ⁹⁹	1Meg x 1 100 NS 27 ⁰⁰
4464 150 NS 14 ⁹⁹	1Meg x 1 80 NS 31 ⁰⁰
4164 150 NS 2 ⁹⁹	
4164 120 NS 3 ⁹⁹	Simms Modules
4164 100 NS 3 ⁴⁹	256 x 8 120 NS 79 ⁰⁰
	256 x 9 80 NS 139 ⁰⁰
41256 150 NS 8 ⁹⁹	256 x 9 100 NS 109 ⁰⁰
41256 120 NS 9 ⁹⁹	1Meg x 9 120 NS 319 ⁰⁰
41256 100 NS 10 ⁹⁹	256 x 9 120 NS 99 ⁰⁰
41256 80 NS 11 ⁰⁰	1Meg x 9 100 NS 349 ⁰⁰
	1Meg x 9 80 NS 449 ⁰⁰
	1Meg x 8 120 NS 279 ⁰⁰

MISCELLANEOUS

2nd Serial Upgrade	9 ⁰⁰
2764-25	3 ⁰⁰
4128	3 ⁰⁰

We Carry Dips - Zips - Simms - Ssj - PLCC - Sipp All Speeds — CALL

Seagate HARD DRIVES

1 YEAR WARRANTY

COMPLETE KITS

ST125 20Meg 40 Mil 1/2 Ht 3/2" Drive only	279 ⁰⁰
ST225 20Meg w/cont. & Cables	269 ⁰⁰
ST238 30Meg w/cont. & Cables	299 ⁰⁰
ST251 40Meg 1/2 HT 40 Mil w/software	379 ⁰⁰
ST251-1 40Meg, 28 Mil Sec	439 ⁰⁰
ST277R 60MB 40 Mil 1/2 Ht	489 ⁰⁰
ST4026 20Meg Full Ht 40 Mil	279 ⁰⁰
ST4038 30Meg 40 Mil Full Ht	309 ⁰⁰
ST4053 40MB 28 Mil Full Ht	519 ⁰⁰
ST4096 80Meg Full Ht w/software	649 ⁰⁰
Fastrax Software	49 ⁰⁰

MODEMS BY EVEREX™

EV-923 EverCom 12 300/1200 bps Bitcom Software	69 ⁰⁰
EV-941 EverCom 24 2400 Baud Int. Bitcom Software	139 ⁰⁰
EV-945 External 2400 Baud	199 ⁰⁰

For error correcting add \$10.00

Haves Compatible Major Manufacturers

1200 Baud Internal w/Software	59 ⁰⁰
1200 Baud External fully Haves Compatible	99 ⁰⁰
2400 Baud Internal 1/2 card w/software	109 ⁰⁰
2400 Baud External Fully Haves Compatible	129 ⁰⁰

1 Year Warranty

CONTROLLERS BY WESTERN DIGITAL

WX-1 8 Bit 1/2 Sized for XT	79 ⁰⁰
WA-2 16 Bit Full Sized Hard/Floppy	119 ⁰⁰
WD-27X 8 Bit RLL 1/2 Size	89 ⁰⁰
WAH 16 Bit Hard Drive Controller	129 ⁰⁰
RA2 16 Bit RLL Hard/Floppy for AT	159 ⁰⁰
MEAD Floppy Disk Controller for XT, controls 4 drives	29 ⁰⁰
MEAD 1.2 Meg & 360K Controller for XT	69 ⁰⁰
Cable Set for Hard Drive Only	5 ⁰⁰

ON SPECIAL

150 Watt Power Supply Direct PC Replacement	54
Super FDC for XT controls 1,2, 1.44, 720K, 360K	69
1.44 Meg 3 1/2 Floppy Drive	109
HP Laser Jet II	1749
256K Upgrade 150 NS	set 89
10 Meg w/cont.	179
Dos 4.01	89

All Everex Products On Special We'll Beat All Advertisers Prices

MONITORS BY SAMSUNG

1252 12" Amber w/Tilt & Swivel Base	79 ⁰⁰
1257 12" Amber Flat Screen 720 x 350	99 ⁰⁰
1464 14" CGA 640 x 200, 16 colors	239 ⁰⁰
1453 14" EGA 640 x 350, 64 colors/31	369 ⁰⁰
CN4551 EGA 720x480	419 ⁰⁰

IBM CGA/VGA/PGA/EGA Multisync Compatible

FLOPPY DRIVES

360K 1/2 Ht. PC Compatible — Mitsumi	69 ⁰⁰
1.2 Meg Black Face — Mitsumi	89 ⁰⁰
720K 3 1/2" Drive w/5/4" mounting	89 ⁰⁰
1.44 Meg 3 1/2" Drive w/5/4" mounting	109 ⁰⁰
360K Tandon TM100-2 Full Ht.	89 ⁰⁰
160K Tandon TM100-1 Full Ht.	49 ⁰⁰

TAPE BACKUPS

40MB Mini Cartridge, 1.6MB/min, XT	359 ⁰⁰
40MB Mini Cartridge, 3.6MB/min, AT	359 ⁰⁰
40MB Streaming Cassette, 5MB/min w/cont.	589 ⁰⁰
60MB Streaming Cassette, 5MB/min w/cont.	649 ⁰⁰
60MB Streaming 600A, 5MB/min w/Full cont.	849 ⁰⁰
125MB Streaming Cartridge, 5MB/min w/Full cont.	1119 ⁰⁰
Excell 60 Model 60/80	999 ⁰⁰
Excell 125 Model 60/80	1269 ⁰⁰

External Add 195⁰⁰

Liquidation ★ Closeouts ★ Discounted Items ★ Overstocked
SAVE UP TO 90% OFF RETAIL — All New 90 Day Warranty**

LETTER QUALITY PRINTER

DAISYWHEEL PRINTER MANUFACTURED BY C.ITOH

Why pay \$1149 for a C.Itoh
STARWRITER™ F-10
 When our 40 cps letter quality daisywheel printer from the same manufacturer is only
\$39900 ea.

OPTIONS

- 6 ft. Serial Cable \$ 19⁰⁰
- Bidirectional Tractor 149⁰⁰
- Cut Sheet Feeder 199⁰⁰
- Serial to Parallel Converter 99⁰⁰

REPEAT OF A SELLOUT

STANDARD FEATURES

- 40 CPS • Accepts Paper to 15 inches • Form Length and Pitch Set from Control Panel
- Industry compatible ribbon, print wheels and control commands • RS232C Serial Interface

MICROSOFT MOUSE

- In Port with Bus Interface
- Fully IBM Compatible (of course)
- Includes Showpartners and Paint Brush

List \$199 Mead **\$7900**

KRAFT MONITOR

FREE TILT SWIVEL BASE

- 14" Flat Screen • Paper White Phosphorus
- TTL Monochrome & RGB Composite Interface

List \$199 Mead **\$10900**

STATIC BUSTER

Attached to CRT face and keyboard, Static Buster works just like a sponge, dissipating static at a rate of 20,000 volts in less than two seconds.

List 49⁰⁰ Mead 19⁰⁰

AT STYLE / XT CASE

- 2 Bay Standard AT Style Case
- Keylock Power and Hard Drive LED's

List 99⁰⁰ Mead 29⁰⁰

TEAC

360K Floppy Drive

- 360K White Faceplate • 1/2 HT / 55BV

List 199⁰⁰ Mead 74⁰⁰

MINISCRIBE HARD DRIVES

MODEL 3053

- 40MB • 28 Mil Sec • 5 1/4 MFM • 1/2 Height

List 615⁰⁰ Mead 379⁰⁰

MODEL 6085

- 72MB • 28 Mil Sec • 5 1/4 MFM • Full Height

List 879⁰⁰ Mead 529⁰⁰

800-654-7762
 SALES: 7 a.m.-6 p.m. PST
702-294-0204
 CUSTOMER SERVICE / ORDER STATUS:
 9 a.m.-4 p.m. PST
FAX 702-294-1168

WE ALSO PURCHASE EXCESS INVENTORY— FAX LIST



- Quantity Pricing Available — CALL
- We Accept International Orders

NO SURCHARGE FOR MC/VISA
TERMS:
 MC • VISA • COD • CASH
 Purchase Orders from Qualified Firms
 Personal Checks • AE add 4%
 20% Restocking Fee on Non-Defective Returns



SHIPPING: (min. 62⁹⁵) UPS

1000 Nevada Hwy. • Unit 101 • Boulder City, NV 89005

DYNAMIC RAMS

SIMM 80/100	\$CALL
1MBIT 100ns	\$22.00
514256 100ns	\$24.00
41464 150ns	\$ 8.50
41256 120ns	\$ 8.50
✓ 41256 150ns	\$ 8.25
✓ 51258 100ns	\$ 9.50
✓ 4164 150ns	\$ 2.85

* For high-speed, Zip, Pcc, Simm Please Call!

PROCESSORS		E PROMS	
80387-25 25MHz	\$525.00	27C101 250ns	\$ 23.00
80387-20 20MHz	\$425.00	27C512 200ns	\$ 13.00
80387-16 16MHz	\$350.00	27512 250ns	\$ 8.50
80287-12 12MHz	\$295.00	27C256 250ns	\$ 5.50
80287-10 10MHz	\$240.00	27256 250ns	\$ 4.95
80287-8 8MHz	\$210.00	27128A 250ns	\$ 4.75
8087-1 10MHz	\$179.00	27C64A 200ns	\$ 4.25
8087-2 8MHz	\$135.00	2764 250ns	\$ 3.50
V-30 8MHz	\$ 12.75	S. RAMS	
V-20 8/10MHz	\$ 8.5/15	43256 120ns	\$ 19.95
		4364 150ns	\$ 11.50

I.C. EXPRESS

15358 Valley Blvd. City of Industry, CA 91746 Tel: 818-369-2688
 ORDER TOLL FREE (Mon-Fri 8-5 PST)
 (800) 892-8889 • (800) 882-8181
outside california inside california
 CALL FOR CURRENT PRICES & VOLUME DISCOUNTS.
 Price shown for cash. MasterCard/Visa add 3%. Prices are subject to change.
 Minimum order \$10.00. Shipping & Handling UPS Ground \$5.00. Air \$7.00 (1 lb.)
 ALL MERCHANDISE IS 100% GUARANTEED WITH PROMPT DELIVERY.

Circle 131 on Reader Service Card

NEW MULTI-CHANNEL PS/2



COMMUNICATION BOARD

- Four Independent RS-232 Ports
- Flexible Interrupt/Address Options
- Discounts Available
- For Models 50, 60, 80

1-800-553-1170



QUA TECH INCORPORATED

478 E. Exchange St., Akron, OH 44304
 TEL: (216) 434-3154 FAX: (216) 434-1409
 TLX: 5101012726

Circle 238 on Reader Service Card

RS-232 FOR PS/2



MODELS 50, 60, 80

- DCE/DTE Selectable
- Transfers to 19.2 K baud
- Address Selectable
- Interrupt Selectable

1-800-553-1170



QUA TECH INCORPORATED

478 E. Exchange St., Akron, OH 44304
 TEL: (216) 434-3154 FAX: (216) 434-1409
 TLX: 5101012726

Circle 239 on Reader Service Card

EZ-WRITER

(E)EPROM Multiprogrammer™

DATA I/O 212* Performance On 1/2 The Budget!

FROM **\$795** 100% USA Made



- Supports (E)EPROMs up to 40 pins including megabit and microcontroller parts
- Stand-alone or computer remote operation
- Parallel port standard
- On board RAM, expandable to 8 megabits



1-800-523-1565
 FAX (407) 994-3615
 TELEX 4998369 BYTEK

• BYTEK Corporation Instrument Systems Division
 508 N.W. 77th Street, Boca Raton, FL 33487
* DATA I/O is a registered trademark of DATA I/O Corporation

Circle 49 on Reader Service Card

RS-422/232 CURRENT LOOP

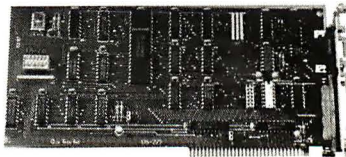

DS-225

- Single channel async communication board for IBM PC/XT/AT
- Software selectable to be RS/422/485, 232 or Current Loop
- Selectable Address & Interrupt

1-800-553-1170



QUA TECH INCORPORATED

478 E. Exchange St., Akron, OH 44304
 (216) 434-3154 TLX: 5101012726

Circle 240 on Reader Service Card

RS-422 Communications Board

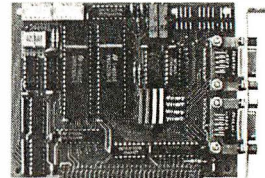

- For IBM PC/XT/AT/PS/2
- Dual channel RS-422/RS-485
- Selectable/shareable interrupts
- Differential drivers to 4000 ft.
- Immediate delivery

1-800-553-1170



QUA TECH INCORPORATED

Leaders in Communication Technology
 478 E. Exchange St., Akron, OH 44304
 (216) 434-3154 TLX: 5101012726

Circle 241 on Reader Service Card

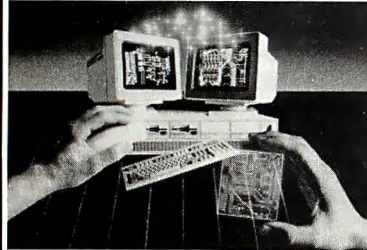

New, Gridless, 100% Autorouting
 Create schematics and PCBs quickly and simply with **HiWIRE-Plus**® and your IBM PC. With the new, gridless, multilayer autorouter (AR) for HiWIRE-Plus, creating printed-circuit layouts is even faster. AR and HiWIRE-Plus are each \$895 and come with 30-day money-back guarantees. Credit cards welcome.



WINTEK Corporation

1801 South St., Lafayette, IN 47904
 (800) 742-6809 or (317) 742-8428

Circle 301 on Reader Service Card

COMPACT /AT DISKLESS SOLUTIONS...



COMDEX
 SPRING '89
 #1465N

CAT908



SOLID STATE DISK EMULATOR

Up To 1M RAM
I-Serial I-Video

12 MHz 80286

... Add LAN Card To Create Diskless Workstation Platform.

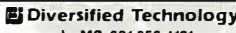

Diversified Technology

In MS 601-856-4121
 TOLL FREE 1-800-443-2667 • FAX 601-856-2888

Circle 331 on Reader Service Card

IN STOCK! SIMMS

1 MEG x 9 100 NS

BEST PRICES ANYWHERE!

Major electronics mfg.
 17 yrs. industry exper.
 will sell 1 or 1,000.

XENTEK SIMMS MART



800-748-5505



Circle 303 on Reader Service Card

California Digital

17700 Figueroa Street • Carson, California 90248

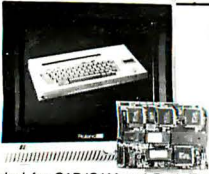

Color Monitor
Better Than **EGA**
\$219

Ideal for CAD/CAM and Desk Top publishing applications. The Roland CD/240 color monitor has a resolution of 720 pixels by 400/480 lines on a .31mm dot pitch 12" non-glare screen. VGA specifications in textmode EGA in graphic mode.
California Digital has made a special purchase and is able to offer the CD/240 EGA/VGA RGB color monitor for only \$219.
Full featured, 132 column, multi-resolution video color adapter card available for only \$139 additional. Comparable card package would retail for \$1095.



20" Analog Color
\$659

Ever try gathering a classroom of students around a 12 inch monitor? This 20 inch analog RGB monitor is the ideal solution. High screen resolution of 1200 pixels by 950 lines allow extra fine detail without the dots looking like golf balls. 256 colors and VGA compatible. Super value originally sold for over \$2000. Only 350 available.

40 Meg. Tape Back-up
\$239



Head Crash, Power Spikes or just poor disk maintenance... Don't loose data because you didn't back up. The Alloy/40 is an inexpensive way to save and restore files in the event that your data has been destroyed.

This 40 megabyte half height tape back is manufactured by North Americas largest producer of data retrieval equipment. No need to purchase a separate tape controller... the Alloy/40 attaches directly to your existing floppy disk controller. Supplied software allows your computer to back up any time Day or Night. Come back in the morning and 40 megabytes of irreplaceable data has been stored on one Scotch DC/2000 data cassette. Back up entire hard disk, modified files only, or by file name. Loss of data is inevitable but when you are backed up on an Alloy/40 its not a catastrophe.



One Two Ten

TEC501 1/2 height sgl.side	49	39	35
TANDON 101/4 full ht. 96 TPI.	99	89	79
FUJITSU 5 1/4" half height	65	63	57
MITSUBISHI new 501 half ht.	119	109	105
MITSUBISHI 504A AT comp.	149	139	135
TEAC FD55BV half height	89	85	79
TEAC FD55FV 96 TPI, half ht.	119	109	105
TEAC FD55FG for IBM AT	109	105	99
PANASONIC 455 Half Height	109	99	89
PANASONIC 475 1.2 Meg./96	119	115	109
Switching power supply			49
Dual enclosure for 5 1/4" drives			59

3 1/2" DISK DRIVES

SONY MP-53W 720K/Byte	129	125	119
SONY MP-73W, 2 Meg.	159	149	call
TEAC 35FN 720 K/Byte	129	119	115
TEAC 35HN/30, 2 Meg.	159	149	145
5 1/4" form factor kit			20

8" DISK DRIVES

QUME 842 double sided	189	179	175
QUME 841 single sided	119	109	99
SHUGART 851R dbl. sided	319	309	299
REMAX RFD4000 dbl. sided	189	179	165
OLIVETTI 851	189	179	165

Hitachi CD-ROM
\$495



Compact disk is a relatively new medium for storage of read-only digital data. One removable disk is capable of storing over 500 megabyte of data on a disk the same size as an audio CD. The CDR-3500 will install in a PC in the space of one 5 1/4" drive. Eclipse 2000 external system with controller and software, \$519. Other CD-ROM Products Available: Sony, Amdek, Toshiba, Panasonic, NEC, Chinson, and Fujitsu.

Build Your Own Computer
\$35



AT Case Only

California Digital has all the components needed to customize your own computer. Buy as much computing power as you need now, and upgrade when the need arises. Here are some examples of components available:

8 slot 10 MHz Mother board\$89	Monochrome card, printer port25
8 slot 12 MHz baby AT Motherboard229	MonoGraphics (hercules) printer port45
Full size five drive AT case35	Color Graphics card49
Four drive XT case25	EGA Color Multi Resolution II159
101/102 AT/XT German mfg. Keyboard57	I/O card, serial & parallel35
200 watt AT power supply59	I/O PLUS, Ser/Par I. clock, game59
Teac 360K/Byte disk drive59	Disk I/O, disk control, clock, game59



Scanner
\$359

The Saba Scanner inputs a printed page in less than three seconds. OCR software allows your computer to transfer printed pages into ASCII files or directly to spreadsheets and word processing programs. Archival data, legal briefs... No problem. Simply inset the page into the Saba and in seconds the document is digested into your computer and ready for editing. Limited quantities available. Original price \$1299; now only \$359.

Hitachi 11 by 17 Plotter
\$895 \$695



The Hitachi 672/XD is a four color 11 by 17 (B size) plotter with superior accuracy and repeatability (.3mm). The 672 accepts HPGL 7475 commands and is both Centronics parallel and RS232C compatible. The 672 plots at a fast eight inches per second in axial direction and eleven inches at an angle of 45 degrees. The plotter also features a self contained digitizing function that allows data to be entered into your computer from printed graphs and blue prints. Four different color pens are supplied with the plotter but a wide variety of technical pens are available.

Heath H/89 Computer
\$179



Hard to believe... but we found a stash of brand new fully factory assembled Zenith/Heath Model H/89s. These computers feature 64K/byte of memory, the Zlog Z-80 CPU and operate under CP/M. The unit incorporates a 12 inch green screen, three serial ports and one 5 1/4" disk drive. Zenith's original price was \$1895. We have still 97 units available for sale, while supplies last we are offering the H/89 at only \$179. CP/M operating system available \$24.95

\$1379



- Two 720K/byte 3 1/2" drives
- 640 K/byte DRAM memory
- 2400 baud internal modem
- Supertwist LCD display
- 16 color RGB/CGA output
- Full feature 101 keyboard

\$695

Take it to school, court, news events or anywhere that you require "computing power" on the go. Built in 2400 bps Hayes compatible modem allows you to transfer data files with your home office or any World wide data base.

A little to large to be called a laptop but the Amstrad 640 is a true battery operated IBM compatible portable. (17 1/2 by 9" footprint). Includes: full featured AT style 101 keyboard • 2400 bps modem • DOS 3.3 • serial port • printer port • carrying case • power adapter and cigarette lighter power cord.



NEC/890 Laser Printer
\$3095

PC Magazine has chosen the NEC-890 best laser printer of the year. (Jan. 12, 1988). And its obvious why... the printer is Postscript, Hewlett Packard, and Apple compatible, and comes standard with three megabytes of memory. The 890 accepts data from parallel, serial and Apple-Talk devices. NEC has also incorporated 40 built-in fonts along with two paper trays into this industrial quality laser printer.

Other Laser Printers Available

Hewlett Packard Laser II, 8 pages per minute \$1659
QMS PS/810 2 Meg., 35 fonts, Postscript 8 pgs 3879
Apple Laser Writer II SE 1979
Texas Instruments 2115 Postscript 15 pgs. 5426
NEC 890/XL (new for Fall 1989) call

40 Megabyte Hard Disk Kit

Forty megabyte internal hard disk drive, controller and cables all for only \$397.

The kit includes the a 40 milisecond Miniscribe 3650 drive and a half slot Western Digital controller.

\$397

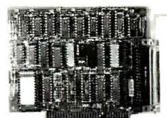

Five Inch Winchester Disk Drives

Price does not include controller. each two+

SEAGATE 225 20 Meg. 1/2 Ht.	239	229
SEAGATE 238 30 Meg. RLL	259	249
SEAGATE 251/151 M. 28mS.	459	445
SEAGATE 4096 96 M. 35mS.	559	539
MINISCRIBE 8425 25 M. 65mS.	239	227
MINISCRIBE 3650 50M 61 ms.	319	309
MINISCRIBE 6085 90 meg.	459	435
MINISCRIBE 3053 25 ms. 1/2ht.	359	339
FUJITSU 2242 55 M. 35mS.	1299	1229
FUJITSU 2243 86 M. 35mS.	1695	1619
RODIME RD-204E 53 Meg.	895	859
MAXTOR XT1140 140 Meg.	1495	1450
MAXTOR XT2190 192 Meg.	1919	1875
TOSHIBA MK56 70 M. 30mS.	1289	1229
CONTROL DATA WREN "3"	call	

Winchester Controllers for IBM/PC

XEBEC 1220 with floppy controller	159
DTT 5150CX	119
OMTI 5527 RLL controller	99
ADAPTEC 2070 RLL controller	99
ADAPTEC 2372A 1/1 interleaf	159
WESTERN DIGITAL WD/1002WX2	189
WESTERN DIGITAL 1003WAH or WA2	139
WESTERN DIGITAL 1007/WA2 ESDI	239
• SCSI/SASI Winchester Controllers •	
XEBEC 1410A 5 1/4" foot print	239
WESTERN DIGITAL 1002-05E 5 1/4"	229
OMTI 20L	89

Winchester Accessories

Dual floppy enc. and powersupply	59
Winchester enclosure and supply	139
Switching power supply	49



Every year since 1973, customers from virtually every nation in the free World have chosen California Digital for their data processing requirements. If its computer, California Digital has it... complete minisystem or just one microchip. California Digital offers over 10,000 unique computer products. Regardless of how specialized your data processing requirements... California Digital is your one stop shopping solution.

TECHNICAL & CALIFORNIA
(213) 217-0500
TOLL FREE ORDER LINE
(800) 421-5041

Telex • (213) 217-1951

**803X/805X In Circuit Emulator
For \$495**

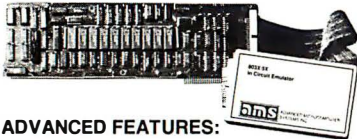

ADVANCED FEATURES:

- 8K-64K of emulation memory
- 64K break points
- 1.5K trace buffer with 7 user test probes
- POD for emulating 8031, 8051, 8032, 8052, and 8053 microcontrollers
- 12 Mhz local microcontroller clock source
- Emulator to PC interface and support software on a 5 1/4" Floppy disk
- User manual
- 1 year limited warranty

ADVANCED MICROCOMPUTER SYSTEMS, INC.
1321 N.W. 65th Place • Ft. Lauderdale, Florida 33309
Phone (305) 975-9515

ams CALL TOLL FREE
1-800-9PC-FREE

Circle 23 on Reader Service Card

TISAR-PC
(Pronounced TY-ZAR)



INVOICING



Keep records the way big business does...
(Hard drive required)

FULLY INTEGRATED

Remarkable Turn-Key System

- Data-base
- Invoicing
- Inventory control
- 3,000 records per file
- 12,000 invoices per file
- Accounts received
- Accounts receivable
- Customer statements
- Mailing labels

LIMITED OFFER
\$79.00

Now with point of entry pricing and user definable fields.

Search, cross-search, fast sorts, reports and much more.

IDEAL for service or sales/mktg businesses. Easy, menu-driven, user friendly, fully tested. Up and running in under 3 minutes. Free customer support.

Call orders 1-800-537-LABS or ask your dealer.



Dealer inquiries invited

JB UNIVERSAL COMPUTER INTERFACE
RS232 ADAPTER TO JB-BUS \$149
The JB universal interface cards connects to RS232C port.
JBAD-16 Analog input, 16 ch, 8-bits, gain 1, 10, 100 \$149
JB-PCMBE motherboard, runs JB & PC I/O cards, 7 slots \$99

PC COMPATIBLE INTERFACE CARDS

DIGITAL OSCILLOSCOPE SYSTEM \$99
AD-1 card & DIG-OSC-8 Software
• Analog input
• 8 bit resolution
• save waveform to disk
• 10K samples/sec.
• High input impedance
• 0-5V range

DAS-12 \$299
• 8 hi-Z, 12-bit S.E. Analog input channels * GAIN of 1, 10, 100
• Full Scale: +/- 10V, 5V, 500mV, 50mV * 25uS conversion
• software to simulate 8 channel DVM, data logger, plot data
• 7 TTL I/O, trigger sampling or control external devices

DAS-8F \$199
• high speed (1.5uS conversion) 8-bit data acquisition system
• 8 hi-Z, S.E. input channels, GAIN of 1, 10, 100, 0-5V Full Scale
• up to 60,000 samples/sec with Digital Oscilloscope software

RLY-DRVR \$99
• 21 hi current, hi voltage (50V, 300mA) Q.C. drivers
UNIVERSAL RELAY CARD - 8 relays, 2 Amp contacts \$129

Prices, availability and specifications are subject to change

JB COMPU-TRONIX
3816 N. Wadsworth Blvd.
Wheat Ridge, CO 80033
(303) 425-9586
Call for FREE CATALOG, accept MC/VISA orders

Circle 141 on Reader Service Card

DISKETTES

- 5.25" DS/DD **29¢**
- 5.25" DS/HD **75¢**
- 3.5" DS/DD **\$1.19**

Price based on quantity of 50 in bulk packaged units - includes sleeves and labels - Minimum shipping/handling \$3.00. VISA, MC Accepted.

Free Catalog

Call, write or circle reader service card for your FREE COPY of our full line catalog.

GAAN Computer Supplies

186 B East Sunnyoaks, Campbell, CA 95008

800-523-1238

In Calif 408-370-6747
FAX 408-370-6823

Mon thru Fri
8 am-5 pm (Calif)

Circle 107 on Reader Service Card

20Mhz 386

80387 Mathcoprocessor Support
32 Bit memory bus
1MEG on board expandable to 8 meg
NCL disk controller/1.2M floppy drive
TTL mono monitor with MGP card/parallel port
Enhanced Keyboard - 102 keys
Newton Rating S1-23

\$1650.00

12Mhz 286

Intel 80286, 8/12Mhz switchable
640k on board expandable to 1Meg
NCL disk controller with 1.2M Floppy drive
TTL mono monitor with MGP card/parallel port
Enhanced Keyboard - 102 keys

\$945.00

10Mhz 88

NEC V20 CPU, 4.77/10 switchable
840k on board
360k Floppy Drive with controller
TTL mono monitor with MGP card/parallel port
Enhanced keyboard - 102 keys

\$565.00

J-TECH CORP

15358 Valley Blvd. City of Industry, CA 91746 Tel: 818-369-1727
ORDER HOUR: (Mon-Fri 8-5 PST)
(800) 543-2525 • (818) 369-1332
Costa Mesa, CA 92626
CALL FOR CURRENT PRICES & VOLUME DISCOUNTS.
Price Shown for cash. MasterCard/VISA add 3%. Prices are subject to change.
Minimum order \$25.00. Shipping & Handling extra by UPS Ground/Air.
ALL MERCHANDISE HAVE 90 DAYS WARRANTY WITH PROMPT DELIVERY.

Circle 132 on Reader Service Card

The UnVT

Z-STEM



VT340
Color Graphics under MS-DOS and Unix

- 800 x 480 on std. VGAs
- true 132 char. lines
- network support
- VT layout keyboard

KEY SYSTEMS LTD.

2150 West Broadway, Suite 412
Vancouver, B.C. Canada V6K 4L9
Tel: 604-732-7411 Fax: 604-732-0715

Circle 145 on Reader Service Card

Add-Ons for the Blind

What you add on to your computer, if you're a blind operator, is almost more important than the computer itself.

Scanners, modems, braille printers, speech synthesizers, braille output devices and a host of other peripherals are described in "Add-Ons: The Ultimate Guide to Peripherals for the Blind Computer User."

The product reviews contained in this book are written by those who know them best—blind computer users.

\$16.95 for braille or cassette
\$19.95 for print.

Send orders to:

National Braille Press Inc.
88 St. Stephen Street, Boston, MA 02115
(617) 266-6160

NBP is a nonprofit braille printing and publishing house.

Circle 141 on Reader Service Card

We'll offer you incredible price!!

JEIKO COMPUTER, CONNECTORS & CABLE ASSEMBLIES

What do you want in the way of connectors and cable assemblies for IBM, PC, XT, AT ... and other computers? We can supply it all!
• Special designs and OEMs welcomed!
• Overseas agents wanted!

A Specialized Manufacturer

us\$3.0 **us\$1.2** **us\$1.0**

PC/AT disk drive cable, HDD cable, FDD cable

us\$3.5 **us\$1.9** **us\$9.0**

Centronics parallel cable, Print cable, DATA Switch (A, B)

JEIKO COMPUTER CO., LTD.
P.O. BOX 10215, Taipei, Taiwan, R.O.C.
TELEX: "23122 JEIKO"
FAX: 886-2-7713855
TEL: (02) 772-8135, 772-8219

Circle 142 on Reader Service Card

ICs PROMPT DELIVERY!!!
SAME DAY SHIPPING (USUALLY)
QUANTITY ONE PRICES SHOWN for FEB. 19, 1989

OUTSIDE OKLAHOMA: NO SALES TAX

FOR: (1) PS/70 OR PS/160 1MbPro (2) DELL COMP/NO (3) AST ATX (4) NCL EX (5) PS/2 Tandy W/SE	DYNAMIC RAM		
	SIMM (1)	256Kx36	80 ns \$650.00
	SIMM (2)	1Mx9	80 ns \$370.00
	SIMM (1)	256Kx1	60 ns 150.00
	1Mbit	1Mx1	80 ns 34.50
	1Mbit	1Mx1	100 ns 25.50
	41256	256Kx1	60 ns 11.25
	41256	256Kx1	100 ns 10.95
	51258 (3)	256Kx1	100 ns 12.95
	41256	256Kx1	120 ns 9.50
41264 (4)	64Kx4	120 ns 14.50	(3) STATIC DRAM (4) 2-PORT VIDEO RAM (5) 80387-16 80387-8 80387-2 80387-2 \$145.00 \$230.00
EPROM			
27C1000	128Kx8	200 ns \$28.50	
27C512	64Kx8	200 ns 13.95	
27256	32Kx8	150 ns 8.15	
27128	16Kx8	250 ns 4.95	
STATIC RAM			
62256P-10	32Kx8	100 ns \$20.50	
6264P-12	8Kx8	120 ns 9.75	
6116AP-12	2Kx8	120 ns 5.50	

OPEN 6 1/2 DAYS, 7-30 AM-10 PM: SHIP VIA FED-EX ON SAT.

WE EXPORT ONLY TO CANADA, GUAM, PUERTO RICO & VIRGIN ISLANDS

SAT DELIVERY INCLUDED ON FED-EX ORDERS RECEIVED BY: THE STD AIR \$6/3 lb FR: P1 \$12.25/1 lb

MasterCard/VISA or UPS CASH COD MICROPROCESSORS UNLIMITED, INC. 24,000 S. Peoria Ave., BEGGS, OK. 74421 (918) 267-4961

No minimum order. Please note: prices subject to change! Shipping, insurance extra, up to \$1 for packing materials.

Circle 180 on Reader Service Card

ACP's HOT SHEET

BELOW WHOLESALE PRICES!

MEMBER
MMC
MICROCOMPUTER
MARKETING COUNCIL
of the Direct Marketing Association, Inc.

SPECIAL BUY!
HANDSCAN
by **saba**TM
299. List 799!

Don't confuse Handscan with other lowest cost scanners on the market...many deluxe features! Never before available at this special low price...order now!

Desktop Publisher's Dream!
Princeton Graphics
LS-300
Full-Page Scanner
Very popular and reliable feed-thru scanner for up to 8.5x11" size sheets. Complete with OCR Software. IBM compatible. Mfg. List \$1199.00!
799.
• WHILE SUPPLY LASTS •

AST Your Choice...
RESEARCH INC. Advantage AT or Rampage AT **88.**

QUADRAM Silver Quad **79.**
(Sixpak compatible)
• Liberty XT, EMS 79.
• Quadsprint Accelerator... 79.

BLOW OUT PRICE!
7995
Pocket Modem™
Migent®
Pocket Modem
We have 1000 units to sell... and when they're gone, they're gone! This popular 1200 Baud pocket modem w/o software has never been offered at such a low price!

OUR NO. 1 SELLERS!!!
Hayes Compatible **1200 Baud**
Internal **49.95** External **74.95**
Hayes Compatible **2400 Baud**
Internal **95.95** External **119.95**
Both are half-cards, with software, plug 'n play!

NUMONICS SPECIAL PURCHASE!!!
Cordless Mouse 8895
Includes drivers, charger, receiver, T-mouse & PC Paint. Reg. 199.95
Manager Mouse 5595
Includes drivers, charger, receiver, T-mouse & PC Paint. Reg. 149.95

Genuine IBM™
5.25" Diskettes
3995 100 pc. box
All disks are from IBM™ and are formatted to PC DOS 360K DS/DD 5-1/4". Disks are programmed but can easily be erased by Deleting Data and reusing the diskettes. You get IBM™ quality Diskettes for only 39¢. All disks are new, formatted and programmed but never used.

Rated No. 1
Box of 10... **699** Qty. 5
1to4, only 7.50 each.
Polaroid® DataRescue™
IBM DS/DD Gray Disks
Backed by DATA RESCUE... Polaroid will retrieve your data FREE if you lose it!

SPECIAL! 512K RAM Upgrade with purchase... 99.
688. ACP Sale Price
Note: FOR THIS PRICE YOU MUST MENTION THIS AD AT TIME OF PURCHASE
AMAX/Advanced 286/10 MHz BareBones
Includes 101-key keyboard, 1.2Mb floppy, floppy/HD controller card, 0K expands to 1 Meg.
Call for Custom Configurations...

SPECIAL PURCHASE!
IBM 299.
Reg. \$895. Roll-A-Bout Computer Workstation
• One lock secures CPU, printer & programs
• 5-plug strip w/mstr switch • Flip-up shelves
• Printers up to 24" wide • 132lb. ship wt.

SPECIAL PURCHASE!!
85Mb Hard Drive
Includes EDSI AT Controller...
Special! Upgrade your IBM™ AT or compatible with our popular 60 ms half-height hard drive.
699.

20 Mb Hard Drive Kit 259.
20 Mb Hard Card 288.
At this low low price, you can't afford not to buy one... our next shipment the price will go up...
30Mb... 339.

Tecmar "Micro RAM" PS/2
Expand your PS/2 up to 8Mb
Reg. Retail \$439. **5995**
ACP Sale Price
734-0003 • While Supply Lasts

QuickLink IV 4-User LAN
by Cubix
• 4 286 Processors
• 786K RAM per user (3Mb total)
• NOVELL CERTIFIED
• Your PC/AT and 4 terminals give you a fast, inexpensive LAN
Reg. \$2800. **1995.**
ACP Sale...

Toshiba T-1000 • Hayes compatible **266.** Retail \$349.
Modem • Mirror II software
Correspondent™ • 2 yr. warranty Holmes Microsystems

PARADISE™ VGA-PLUS • VGA/EGA/HDA comp. **269.**
• 256K on board
the Performance Leader... Reg. \$399, #625-0004.

Hi-Tech Silicon Corner
• MOT 68881-16 (16 MHz) Coprocessor... 188.
• Intel 80287-6 (8 MHz) Coprocessor... 139.
• DP 8428V-70 1Mb RAM Controller... 14.95
• MOT MC 68766C30 EPROM... 29.95

IBM (Original) Floppy Disk Drive!!!
Original DS/DD 360K Drives, 5-1/4"
5995 Super Price! Factory Boxed
White Quantities Last

"LASERNET" 8 Port Buffer 449.
by Western Telematic Retail \$995.
• 8 Serial Input Ports # 400-0076
• 1 Serial, 1 Parallel Output
• 256K Buffer expands to 2Mb
Model PSU-82C Printer Share
Postscript compatible, Menu-driven, Set-up software

IBM Blowout Sale!!!
Genuine IBM™ AT Prototype Board... 25!
IBM™ IEEE GFIB 99.

this has never been offered to the remarketing channel by IBM™ before... and we bought big! 8 big truckloads of IBM PC.s, expansion boards, memory and over 60,000 real IBM software packages... First come, first served... call for complete list!

- IBM XT/286 1395.
- IBM Writing Assnt. 19.95
- IBM AT/339(OK) 2295.
- IBM Filing Assnt. 19.95
- IBM PC/3270(1Mb) . 1295.
- IBM Fortran 99.95
- IBM PC/XT268 788.
- IBM Xenix 119.95
- IBM PC Voice Comm Card 229.
- IBM 3270 Emulator 24.95
- AT Exp Card w/5 12K . 149.
- IBM 3101 Emulator 69.95
- Monochrome adaptor . 49.
- IBM Education Series
- Color adaptor 49.
- Software, choose 995
- AT Prototype board 25.
- 300 titles from .
- Synchronous Comm send for 16 pg. price list!
- adaptor 49.
- Appointment 19.
- 3270 Exp Card, 1Mb .. 499.
- Asselt catalog 19.
- IBM Reporting Assnt. . 25.
- Mailing Labels 19.
- IBM AT 2Mb Memory
- Data Edition 19.
- Expansion Brd w/OK 69.
- IBM DOS 1.0/3.1 from 9.95

IBM™ Filing Assistant BUNDLE-all 5 pkgs. 79.95!
• IBM Filing Assistant, Reg. \$204.00! 19.95
• IBM Assistant Executives Solutions (regs. Filing Ass't) . 24.95
• IBM Assistant Accounting Solutions (regs. Filing Ass't) . 24.95
• IBM Assistant Home Solutions (regs. Filing Ass't) 24.95

IBM™ Decision Series BUNDLE-all 4 pkgs. 79.95!
• IBM Data Edition, Reg. \$255.00 24.95
• IBM Reports+ Edition, Reg. \$204.00 19.95
• IBM Graphs Edition, Reg. \$204.00 19.95
• IBM Plans+ Edition, Reg. \$335.00 29.95

Call for complete listing and get deals like these...
IBM™ Language Education BUNDL. Easy 10 pkgs 129.95
or IBM™ Science Education BUNDL. Easy 10 pkgs 139.95

CALL FOR TOSHIBA LAPTOPS!!
499. TOSHIBA 321SL Sale!
PRINTER BARGAIN HUNTERS!!!
CITIZEN ACP's • 120d... 144.95
Sale! • 180d... 169.95

BLOW-OUT PRICE!
IBM 2Mb/OK
Memory Expansion Board
for AT or compatibles **69.** While Supply Lasts!
Unbelievable Low Price...
• 512K AT Memory Expansion Board/512K... 149.

VGA Package Deal!
625. Complete package... card plus monitor at one low price!
Low Cost... High Quality!!!
• 800 x 460 Resolution • IBM software
• 640 x 480-16 colors • ATI VGA card
• 320 x 200-256 colors • VGA, EGA, HDA

ACP's Special Wholesale Price... **995** New!... from RAY-O-VAC®
AT Replacement Battery
Direct replacement for AT/286/386 real-time clocks

Software Sale! IBM Writing Ass't, v2. 59.
Lotus 1-2-3 .. 325. Word Perfect 258.
Ventura 499. Excel 299.

419 Multisynch Compatible
MULTISYNCH MONITOR
... ACP's Sale Price!

for the **FASTEST SERVICE** order by phone...
Mail Orders: P.O. Box 17329 Irvine, CA 92713
Retail: 1310 E. Edinger, Santa Ana, CA 92705
Advanced Computer Products, Inc.
Authorized dealers for Hyundai • AST • Epson • Citizen • NEC • Okidata • Maxell • Seagate
Magnavox • Sony • Toshiba • Sharp • HP • Intel • Microsoft • Ventura • Aldus • many more...

Order by phone
800-FONE ACP
800-366-3227 • 714-558-8813
Customer Service 714-558-1356

• \$2500 Minimum MAIL ORDER
• No Surcharge for VISA or Mastercard
• Volume purchasing agreements available
• Pricing subject to change without notice
• ACP Retail store pricing may vary. Not responsible for typos.
• Limited warranties and other conditions may apply.
• Orders subject to availability
• Supply limited on certain items
• Limited quantities and other conditions may apply.
Call for Corporate VPA's...
New Flyer now avail. CALL!

NEC V20 & V30 CHIPS

Replace the 8086 or 8088 in Your IBM PC and Increase Its Speed by up to 30%!

Part No.	Price	Part No.	Price
UPD70108-5 (5MHz) V20 Chip	\$ 7.49		
UPD70108-8 (8MHz) V20 Chip	\$10.75 \$ 9.49		
UPD70108-10 (10MHz) V20 Chip	\$12.95 \$12.25		
UPD70116-8 (8MHz) V30 Chip	\$9.95 \$ 7.95		
UPD70116-10 (10MHz) V30 Chip	\$16.95 \$15.49		

7400

Part No.	1-9	10+	Part No.	1-9	10+
7400	SALE 15	7485	SALE 45		
7402	29	7486	SALE 29		
7404	SALE 15	7489	1.95 1.85		
7405	35 25	7490	49 39		
7406	39 29	7493	45 35		
7407	SALE 25	74121	SALE 25		
7408	35 25	74123	SALE 35		
7414	SALE 15	74125	SALE 35		
7416	SALE 19	74126	SALE 35		
7417	SALE 19	74143	SALE 3.95		
7420	29	74150	SALE 11.10		
7430	SALE 15	74154	1.35 1.25		
7432	39 29	74158	SALE 1.25		
7438	SALE 25	74173	SALE 35		
7442	SALE 29	74174	SALE 35		
7445	SALE 59	74176	SALE 49		
7446	89 79	74181	SALE 1.49		
7447	89 79	74189	SALE 1.49		
7448	1.95 1.85	74193	79 59		
7472	39 29	74221	SALE 69		
7473	39 29	74221	SALE 69		
7474	SALE 25	74273	SALE 1.49		
7475	49 39	74365	SALE 35		
7476	45 35	74367	SALE 35		

74LS

74LS00	SALE 15	74LS165	75 65
74LS02	SALE 15	74LS166	SALE 69
74LS04	SALE 16	74LS173	25 25
74LS05	SALE 16	74LS174	SALE 25
74LS06	59 49	74LS175	SALE 25
74LS07	59 49	74LS189	SALE 2.95
74LS08	28 18	74LS191	SALE 3.95
74LS10	SALE 15	74LS193	69 59
74LS14	SALE 29	74LS221	SALE 49
74LS27	SALE 15	74LS240	SALE 45
74LS30	SALE 15	74LS243	SALE 45
74LS32	SALE 19	74LS244	SALE 49
74LS42	49 39	74LS245	SALE 59
74LS47	89 79	74LS259	99 89
74LS73	SALE 25	74LS273	89 79
74LS74	SALE 19	74LS279	49 39
74LS75	SALE 25	74LS285	3.49 3.39
74LS76	39 29	74LS365	SALE 35
74LS85	59 49	74LS366	SALE 35
74LS86	29 19	74LS367	SALE 29
74LS90	SALE 29	74LS368	SALE 35
74LS93	SALE 29	74LS373	SALE 59
74LS123	SALE 39	74LS374	SALE 49
74LS125	SALE 39	74LS393	SALE 59
74LS138	49 39	74LS590	5.95 5.85
74LS139	SALE 29	74LS624	1.95 1.85
74LS154	1.19 1.09	74LS629	SALE 1.95
74LS157	45 35	74LS640	SALE 89
74LS158	SALE 25	74LS645	SALE 89
74LS163	SALE 35	74LS70	SALE 79
74LS164	SALE 35	74LS688	2.39 2.29

74SPROMS*

74S00	SALE 19	74S188*	1.49
74S04	SALE 19	74S189	1.49
74S08	SALE 19	74S196	SALE 99
74S10	SALE 19	74S240	1.39
74S32	SALE 19	74S244	SALE 75
74S74	SALE 19	74S253	SALE 29
74S85	SALE 19	74S273	1.49
74S86	SALE 19	74S288*	1.49
74S124	SALE 1.25	74S373	SALE 99
74S174	SALE 25	74S374	SALE 99
74S175	SALE 25	74S472*	SALE 2.49

CD-CMOS

CD4001	19	CD4076	59
CD4008	19	CD4081	22
CD4011	19	CD4082	22
CD4013	29	CD4093	35
CD4016	29	CD4094	39
CD4017	49	CD40103	1.49
CD4018	59	CD40107	49
CD4020	59	CD4510	69
CD4024	45	CD4511	69
CD4027	35	CD4520	79
CD4030	29	CD4522	79
CD4040	65	CD4538	79
CD4049	29	CD4541	89
CD4050	29	CD4543	79
CD4051	59	CD4553	3.95
CD4052	59	CD4555	79
CD4053	59	CD4559	1.49
CD4063	1.49	CD4559	1.95
CD4066	29	CD4566	7.95
CD4067	1.49	CD4583	59
CD4069	19	CD4584	49
CD4070	29	CD4589	69
CD4071	22	MC14411P	7.95
CD4072	22	MC14490P	4.49

EEPROMS

2816A	2048x8	350ns (9V-15V) 5V Read/Write	5.25
2816A-25	2048x8	350ns (9V-15V) 5V Read/Write	5.49
2817A	2048x8	350ns 5V Read/Write	6.95
2864A	8192x8	250ns 5V Read/Write (Pn 1, No R/B)	13.95
2864A-30	8192x8	300ns 5V Read/Write (Pn 1, No R/B)	12.95
2865A-30	8192x8	300ns 5V Read/Write	9.95
52B13	2048x8	350ns (21V) 5V Read Only	1.49

MICROPROCESSOR COMPONENTS

MISCELLANEOUS CHIPS

D765AC	995 2.95
WD9216	3.95
Z80, Z80A, Z80B SERIES	
Z80	1.19
Z80-CTC	1.49 99
Z80-PI	1.29 99
Z80A	1.29
Z80A-CTC	1.65
Z80A-DART	4.99 3.95
Z80A-PI	1.99 1.49
Z80A-SIO10	3.95 99
Z80B	2.75
Z80B-CTC	9.95 3.25
Z80B-PI	3.95
Z80B-SIO	4.95
Z8671	1.59
Z8681B1	8.95

8000 SERIES

8031	995 3.49
80C31	995 8.95
8035	1.49 1.25
8039	1.95 1.59
8052AHASIC	24.95
8052ABASIC	2.49
8085A	2.49
8086	7.95
8086-2	6.95 5.49

STATIC RAMS

Part No.	Function	120ns	Price
2016-12	2048x8	120ns	4.95 3.75
2018-45	2048x8	45ns 300ML	6.95
2102	1024x1	350ns	99 89
2114N	450ns	1024x1	1.49
214N-2L	1024x4	200ns Low Power	1.49
21C14	1024x4	200ns (CMOS)	2.95
5101	256x4	450ns (CMOS)	2.95 2.49
6116P-1	2048x8	100ns (16K) CMOS	6.25 3.95
6116P-3	2048x8	150ns (16K) CMOS	4.95 3.49
6118P-1	2048x8	100ns (16K) LP CMOS	6.49 3.49
6264P-10	8192x8	100ns (64K) CMOS	5.49 3.95
6264P-15	8192x8	100ns (64K) CMOS	9.25
6264P-10	8192x8	100ns (64K) LP CMOS	10.95
6264P-12	8192x8	120ns (64K) LP CMOS	10.49
6264P-15	8192x8	150ns (64K) LP CMOS	10.25
6514	1024x4	350ns (256K) Low Power	3.75 3.49
43256-10L	32,768x8	150ns (256K) LP CMOS	20.95
43256-15L	32,768x8	150ns (256K) LP CMOS	22.95
62256P-85	32,768x8	100ns (256K) LP CMOS	21.95
62256P-12	32,768x8	120ns (256K) LP CMOS	20.95

DYNAMIC RAMS

THM91000L-10	1,048,576x9	100ns 1Megx9 SIM.	549.95 399.95
THM91000S-10	1,048,576x9	100ns 1Megx9 SIM.	399.95
THM91000L-80	1,048,576x80	80ns 1Megx9 SIM.	419.95
THM91000S-80	1,048,576x80	80ns 1Megx9 SIM.	419.95
TMS4416-12	16,384x4	120ns	7.75 6.25
TMS4416-15	16,384x4	150ns	7.25 6.25
4128-15	131,072x1	150ns (Poggyback)	3.29
4164-100	65,536x1	100ns	5.49
4164-120	65,536x1	120ns	2.95
4164-150	65,536x1	150ns	2.59
4126-60	262,144x1	60ns	13.49
4126-80	262,144x1	80ns	12.49
4126-100	262,144x1	100ns	11.95
4126-120	262,144x1	120ns	11.95
4126-150	262,144x1	150ns	11.49
4126-12	64Kx4	120ns Video RAM	19.95
4146-14	65,536x4	120ns	13.95 14.49
4146-12	65,536x4	120ns	14.99 13.95
4146-15	150ns	100ns Static Column	10.95
51258-10	262,144x1	100ns	14.95
85227-10PL	262,144x9	100ns 256Kx9 SIP	149.95
85227-10P	262,144x9	100ns 256Kx9 SIM	149.95
511000P-10	1,048,576x1	100ns (1 Meg)	399.95 29.95
511000P-80	1,048,576x1	80ns (1 Meg)	42.95
511000P-85	1,048,576x1	85ns (1 Meg)	44.95 41.95
514256P-10	262,144x4	100ns (1 Meg)	44.95 34.95

EPROMS

TMS2516	2048x8	450ns (25V)	6.95 5.95
TMS2532	4096x8	450ns (25V)	6.95 4.49
TMS2532A	4096x8	450ns (12.5V)	4.49 3.25
TMS2564	8192x8	450ns (25V)	6.95 4.95
TMS2716	2048x8	450ns (-3V, +5, +12V)	6.95 4.49
1702A	256x8	(1uL)	4.95
2708	1024x8	450ns	6.95
2716	2048x8	450ns (25V)	3.75
2716-1	2048x8	350ns (25V)	4.25 3.95
27C16	2048x8	450ns (25V) CMOS	4.25 3.95
27C16-25	450ns (25V)		3.95
2732A-20	4096x8	250ns (21V)	4.25
2732A-25	4096x8	250ns (21V)	3.95
27C32	4096x8	450ns (25V) CMOS	4.95 4.25
2764-20	8192x8	250ns (21V)	4.25
2764-25	8192x8	250ns (21V)	3.59
2764-45	8192x8	450ns (25V)	3.95
2764A-25	8192x8	250ns (12.5V)	3.69
27064-15	8192x8	150ns (12.5V) CMOS	5.95
27128-20	16,384x8	200ns (21V)	6.95 4.49
27128-25	16,384x8	250ns (21V)	5.95
27128A-25	16,384x8	250ns (12.5V)	7.75
27128B-25	16,384x8	250ns (12.5V)	5.75 5.25
27128C-25	16,384x8	250ns (21V) CMOS	5.25 3.95
27256-15	32,768x8	150ns (12.5V)	8.95
27256-20	32,768x8	200ns (12.5V)	6.96 6.25
27256-25	32,768x8	250ns (12.5V)	5.49
27256-45	32,768x8	450ns (25V)	6.95
27256-60	32,768x8	150ns (12.5V) CMOS	7.95
27256-80	32,768x8	250ns (12.5V) CMOS	6.25 4.49
27512-20	65,536x8	200ns (12.5V)	10.95
27512-25	65,536x8		

Now Available...Jameco's NEW Winter/Spring Flyer #138 with 48 pages of Computer Peripherals, Components & More!

15th ANNIVERSARY YEAR 1974 - 1989

TEST EQUIPMENT

Metex Digital Multimeters

Metex General Specs:

- Handheld, high accuracy
- AC/DC Voltage, AC/DC Current, Resistance, Diodes, Continuity, Transistor hFE • Manual ranging w/overflow protection
- M3650/B & M4650 only:**
- Also measures frequency and capacitance
- M4650 only:**
- Data Hold Switch
- 4.5 Digit



M4650 Pictured

M3610	3.5 Digit Multimeter.....	\$49.95
M3650	3.5 Digit w/Freq. & Capacitance, \$69.95	
M3650B	Same as M3650 w/Bargraph.....	\$79.95
M4650	4.5 Dig. w/Freq., Capacitance and Data Hold Switch.....	\$99.95

Metex Autoranging Jumbo Readout DMM

• AC/DC Voltage, AC/DC Current, Resistance, Diodes, Continuity and Frequency

- 3.75 Digit (8" High)
- Ruggedized, Water-resistant case
- Easy-to-use pushbutton switches



M80.....\$59.95

COMPUTER ACCESSORIES

DFI Handy Scanner and 3 Button Mouse for IBM PC/XT/AT

FREE DPE Software with HS3000!

The HS3000 offers a full 4 inch window at 400dpi resolution. Scan photos, logos, drawings, etc. Can be used with today's most popular applications.

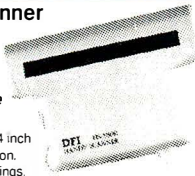

HS3000 Pictured

HS3000	Handy Scanner.....	\$199.95
DMS200	200DPI 3-Button Ser. Mouse	\$49.95
DMS200S	200DPI 3-Button Ser. Mouse with Dr. Halo Software	\$59.95

Additional IBM Compatible Accessories

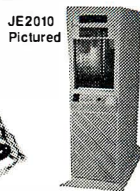

JE2010 Pictured

JE1030 Pictured	Flip-Top Standard PC/XT Case.....	\$34.95
JE1014	Flip-Top Baby XT Turbo Case.....	\$69.95
JE1017	Flip-Top Baby AT Case.....	\$69.95
JE1018	Slide Baby AT Case.....	\$59.95
JE1030	150 watt PC/XT Power Supply.....	\$59.95
JE1032	200 watt Baby AT Power Supply.....	\$89.95
JE2010	Tower Case w/250 watt Pwr. Supply.....	\$299.95

2400/1200/300 Baud Modems Datalronics

• Hayes command compatible

- Bell 103/212A compatible
- Auto-dial/auto-answer • FCC approved • 1-year warranty • Includes MaxiMite Communication Software (except 1200P)



1200P	1200/300 Baud Pocket Size Modem.....	\$99.95
1200H	1200/300 Baud Internal Modem.....	\$69.95
2400H	2400/1200/300 Baud Internal Modem.....	\$129.95
1200C	1200/300 Baud External Modem.....	\$99.95
2400C	2400/1200/300 Baud External Modem.....	\$169.95

1355 Shoreway Road Belmont, CA 94002

24 Hour Order Hotline (415) 592-8097
 FAX's (415) 592-2503 or (415) 595-2664
 Telex 176043 - Ans. Back: Jameco Blmt
 Data Sheets - 50c each
 Send \$2.00 Postage for a FREE 1989 CATALOG
 © 1989 Jameco Electronics 4/89
 IBM is a registered trademark of International Business Machines

Jameco 12MHz IBM AT Compatible Kit With 512K RAM

- Free! QAPLUS Diagnostic Software Included!
- Free! PC Write Word Processing Software Included!
- 512K RAM Included, Expandable to 4MB
- AMI BIOS ROMs Included
- 8 or 12MHz Operation
- Regular \$934.52 value for only \$799.95!
- Flip-Top Case w/200 Watt Power Supply
- 1.2MB Disk Drive
- 13.7 Norton SI Rating
- 101-Key (Enhanced) Keyboard

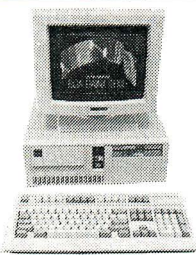

Shown with EGA Option (not included)
 JE1059 Monitor and Adapter Card \$519.95 (See Below)

JE3008	12MHz IBM AT Compatible Kit.....	\$799.95
EZDOS	Digital Research MS/PC-DOS Comp. Operating Sys....	\$49.95
EZDOSP	Same as above with TrueBASIC.....	\$69.95

IBM COMPATIBLE DISPLAY MONITORS

AMBER	12" Amber Mono.	\$99.95
CTX2410	14" RGB 640x200	\$279.95
TM5154	EGA 14" 720x350	\$399.95
JE1059	EGA Monitor & Card	\$519.95
TM5155	14" Multiscan 800x560	\$499.95
QC1478	14" VGA 720x480	\$449.95
JE2055	VGA Monitor & Card	\$649.95



QC1478 Pictured

JAMECO IBM PC/XT/AT COMPATIBLE CARDS

JE1041	20/40MB Hard Disk Controller Card (PC/XT).....	\$79.95
JE1043	360K/720K/1.2MB/1.44MB Floppy Disk Controller Card (PC/XT/AT).....	\$49.95
JE1044	360K Floppy/Hard Disk Controller Card (PC/XT).....	\$129.95
JE1045	360K/720K/1.2MB/1.44MB Floppy/Hard Disk Controller Card (AT).....	\$149.95
JE1050	Monochrome Graphics Card w/Parallel Printer Port (PC/XT/AT).....	\$59.95
JE1052	Color Graphics Card w/Parallel Printer Port (PC/XT/AT).....	\$49.95
JE1055	EGA Card w/256K Video RAM (PC/XT/AT).....	\$159.95
GC1509	Orchid 8-Bit VGA Card w/256K Video RAM (PC/XT/AT).....	\$269.95
GC1501	Orchid 8/16-Bit VGA Card w/256K Video RAM (PC/XT/AT).....	\$349.95
JE1060	I/O Card w/Serial, Game, Printer Port & Real Time Clock (PC/XT).....	\$59.95
JE1061	RS232 Serial Hall Card (PC/XT).....	\$29.95
JE1062	RS232 Serial Hall Card (AT).....	\$34.95
JE1065	I/O Card w/Serial, Game and Parallel Printer Port (AT).....	\$59.95
JE1071	Multi I/O Card w/Controller & Monochrome Graphics (PC/XT).....	\$119.95
JE1081	2MB Expanded or Extended Memory Card (zero-K on-board) (AT).....	\$119.95

SEAGATE HALF-HEIGHT HARD DISK DRIVES

ST225	20MB Drive only (PC/XT/AT)	\$224.95
ST225XT	20MB w/Controller (PC/XT)	\$269.95
ST225AT	20MB w/Controller (AT)	\$339.95
ST238	30MB Drive only (PC/XT/AT)	\$249.95
ST238XT	30MB w/Controller (PC/XT)	\$299.95
ST238AT	30MB w/Controller (AT)	\$389.95
ST251	40MB Drive only (PC/XT/AT)	\$379.95
ST251XT	40MB w/Controller (PC/XT)	\$419.95
ST251AT	40MB w/Controller (AT)	\$489.95
ST251-1	40MB Fast 28ms (Drive only)	\$469.95

Your One-Stop Center for Hard Disk Drive Needs!

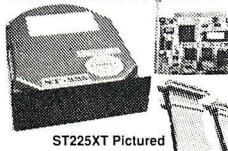

ST225XT Pictured

Seagate 60MB Hard Disk Drives Also Available!

IBM PC/XT/AT COMPATIBLE MOTHERBOARDS

JE1001	4.77/8MHz (PC/XT)	\$89.95
JE1002	4.77/10MHz (PC/XT)	\$109.95
JE3005	Baby 8/12MHz (AT)	\$329.95
JE3010	Baby 8/16MHz NEAT (AT)	\$469.95
JE3020	Baby 16MHz 80386 (AT)	\$1199.95
JE3025	Baby 20MHz 80386 (AT)	\$1499.95
JE3026	Full-Size 25MHz 80386 (AT)	\$2299.95



JE3025 Pictured

IBM PC/XT/AT COMPATIBLE 3.5"/5.25" DISK DRIVES

352KU	3.5" 720KB (PC/XT/AT)	\$109.95
356KU	3.5" 1.44MB (PC/XT/AT)	\$129.95
JE1020	5.25" 360KB (PC/XT/AT) Black	\$89.95
JE1021	5.25" 360KB (PC/XT/AT) Beige	\$89.95
JE1022	5.25" 1.2MB (PC/XT/AT) Beige	\$99.95



JE1022 Pictured

SUPER SONY SALE

720KB 3.5" Floppy Drive

• For use with IBM PC/XT/AT and compatible computers • Double-sided, double density • 135TPI • 160 tracks • Rotation speed: 300rpm • Size: 4"W x 6"D x 1"H



MPP11.....\$79.95

PROTOTYPING PRODUCTS

Jameco Solderless Breadboards

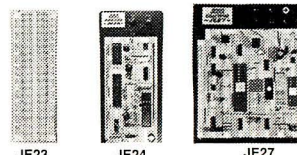

Part No.	Dim. L" x W"	Contact Points	Binding Posts	Price
JE21	3.25x2.125	400	0	\$4.95
JE23	6.5x2.125	830	0	\$7.95
JE24	6.5x3.125	1,360	2	\$12.95
JE25	6.5x4.25	1,660	3	\$19.95
JE26	6.875x5.75	2,390	4	\$24.95
JE27	7.25x7.5	3,220	4	\$34.95

COMPUTER ACCESSORIES

Jameco IBM PC/XT/AT Compatible Keyboards



JE2016 Pictured

JE1015	Standard AT Layout (PC/XT/AT).....	\$59.95
JE1016	Enhanced Layout (PC/XT/AT).....	\$69.95
JE2016	Enh. w/Solar Calculator (PC/XT/AT)....	\$79.95

Jameco Switch Boxes

• Female Connectors • All Pins Switched



JE1170 Pictured

Part No.	Description	Price
JE1170	DB25-pin A/B Switch.....	\$22.95
JE1171	DB25-pin A/B/C Switch.....	\$27.95
JE1172	DB25-pin A/B/C/D Switch.....	\$29.95
JE1173	Centronics36-pin A/B Switch....	\$24.95
JE1174	Centronics36-pin A/B/C Switch..	\$27.95

30MB Hard Disk Card for IBM PC/XT



SA30.....\$379.95

40MB Tape Back-Up for IBM PC/XT/AT

DJ10	40MB Tape Back-Up and Tape... \$349.95
TB40	40MB Tape Cartridge..... \$24.95

ENGINEERING/DATA BOOKS

21035	Sams TTL Cookbook (88)	\$14.95
21398	Sams CMOS Cookbook (88)	\$19.95
22453	Sams Op-Amp Cookbook (88)	\$21.95
270645	Intel 8-bit Controller Hndbk. (89)	\$19.95
270646	Intel 16-bit Controller Hndbk. (89)	\$19.95
270647	Intel 32-bit Controller Hndbk.(89)	\$19.95
400041	NSC Linear Data Book Vol 1 (88)	\$14.95
400042	NSC Linear Data Book Vol 2 (88)	\$9.95
400043	NSC Linear Data Book Vol 3 (88)	\$9.95
ICM89	1989 IC Master (3 Volume Set)	\$129.95

\$20.00 Minimum Order - U.S. Funds Only

CA Residents Add 6%, 6.5% or 7% Sales Tax
 Shipping - Add 5% plus \$1.50 Insurance (May vary according to weight)

Terms: Prices subject to change without notice. We are not responsible for typographical errors. We reserve the right to substitute manufacturers. Items subject to availability and prior sale. Products pictured may only be representative.

Complete list of terms/warranties is available upon request.



Jameco ELECTRONICS



24-Hour Order Hotline (415) 592-8097 • The Following Phone Lines Are Available From 7AM - 5PM P.S.T.:

• Customer Service (415) 592-8121 • Technical Assistance (415) 592-9990 • Credit Department (415) 592-9983 • All Other Inquiries (415) 592-7108



REMOTE DATA ACQUISITION AND CONTROL

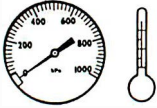

Although affordable, powerful and easy to use, the A-BUS I/O system until recently had a major limitation: it had to be located close to the controlling computer. Now two new serial adapters from Alpha Products have removed this restriction. Any computer with an RS232 port can control the A-BUS line of data acquisition and control cards. Using standard telephone type cable, the A-BUS system can be located up to 500 feet away from the computer. With the addition of a Modem the A-BUS system can be controlled from anywhere. As with all A-BUS cards, the adapters are easily installed and are programmed using standard commands.

NEW SERIAL PROCESSOR HAS BRAIN



Besides implementing a full A-BUS on a serial port, the low cost SP-127 A-BUS Serial Processor fills a great need in remote data acquisition. It includes a complete BASIC interpreter and can run programs independently of the host computer. This distributed processing relieves the host of housekeeping chores and low level decision making. The SP-127 can read and log data at set intervals for later reviewing or recalling at the host's convenience. The Serial Processor, which communicates with any computer through an RS232 port, includes a complete BASIC interpreter and 32K of memory. Adding a Modem turns the SP-127 into an automated remote data and control station.

THE A-BUS ON NETWORK

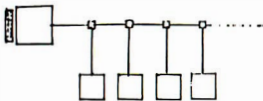

Unique features such as the new "Serial Nodes" greatly expand the usefulness of the A-BUS. These inexpensive (\$49) devices provide the ability to connect up to 16 complete A-BUS systems to a single serial port on any computer. The node also functions as a repeater to increase the reach of the adapter beyond the 500 foot limit. The nodes work in conjunction with the company's SA-129 Serial A-BUS Adapter. Plant-wide data collection and control will become widespread thanks to the system's low cost, outstanding capabilities, and ease of use.

ADVANCE IN MOTION CONTROL

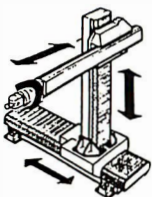

Seeking new heights in motion control and robotics, Alpha's Smart Quad Stepper Controller outperforms systems costing 5-10 times more. This \$299 board includes a multitasking microprocessor capable of controlling 4 stepper motors simultaneously at speeds up to 1000 steps per second. Four Axis positioning is perfect for robot arms, positioners, pick and place, etc. Commands are intuitive; plain English words and a forgiving syntax make it easy to write (and edit) command sequences. Scaling factors allow for meaningful units of your choice, and 32 bit floating point arithmetic ensures accurate calculations. The "learn" feature involves storing a series of movements so that even a complex sequence can be repeated easily. Alpha's engineers thoughtfully included direct drivers for small motors, and a variety of inputs (limit switches, remote keypad, panic button, etc.). An SC-149 can be set up quickly and easily, minimizing development time and allowing more effort to be devoted to the rest of the robotic project.



ALPHA Products

Alpha Industries Company

(203) 656-1806

Darien, CT 06820

A-BUS™ MAGIC

Classroom to advanced industrial applications.

Be a Wizard in your Lab, Factory, College, Home...

It used to be difficult and costly to do process control, robotics, data acquisition, monitoring and sensing with your computer. Now the low-cost A-BUS system makes it easy to do almost any project you can imagine.

Versatility. A-BUS cards handle most interfacing, from on/off switching, to reading temperatures, to moving robot arms, to counting events, to sensing switches...

Adaptability. The A-BUS is modular, allowing expansion well beyond your needs. It works with almost any computer, or even as a remote data station with the new serial adapters.

Simplicity. You can start using the A-BUS in minutes. It's easy to connect, and software is a breeze to write in any language.

Reliability. Careful design and rugged construction make the A-BUS the first choice in specialized I/O.

An A-BUS system consists of: = An A-BUS adapter plugged into your computer = A cable to connect the adapter to 1 or 2 A-BUS function cards. = The same cable will also fit an A-BUS Motherboard for expansion to up to 25 cards in any combination.

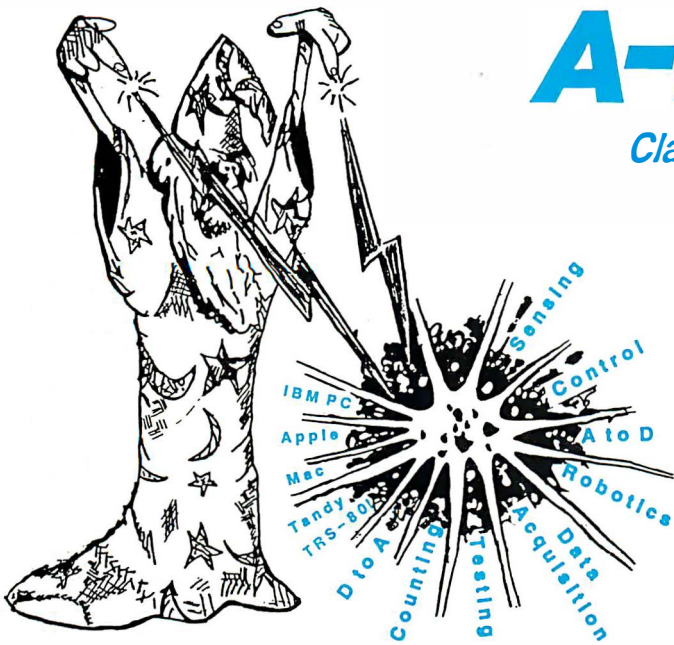

NEW: REMOTE A-BUS! Use the new Serial (RS-232) Adapter or Processor to control any A-BUS system. Cards can be up to 500 ft away using phone type cable, or off premises using a modem. Call or send for the new A-BUS Catalog which covers all the products.

Important

All A-BUS Systems: ♦ Come assembled and tested ♦ Include detailed manuals with schematics and programming examples ♦ Can be used with almost any language (BASIC, Pascal, C, assembler, etc.) using simple "IN" and "OUT" commands (PEEK and POKE on some computers) ♦ Can grow to 25 cards (in any combination) per adapter ♦ Provide jumper selectable addressing on each card ♦ Require a single low cost unregulated 12V power supply ♦ Are usually shipped from stock. (Overnight service is available.)

About Alpha Products

Founded in 1976 for the purpose of developing low cost I/O devices for personal computers, Alpha has grown to serve over 70000 customers in over 60 countries. A-BUS users include many of the Fortune 500 (IBM, Hewlett-Packard, Tandy, Bell Labs, GM...) as well as most major universities. A-BUS products are U.S. designed, U.S. built, and serviced worldwide. Overseas distributors: England: Cady Science Assoc. Ltd., Merseyside, 051 342 7033. Australia: Brumby Technologies Pty. Ltd., NSW, 759 1638. France: Coserm, Rungis, 46 86 64 75

Inputs, Outputs, etc.

Analog Input: 8 analog inputs. 0-5.1V in 20mV steps (8 bits). 0-100V range possible. 7500 conversions/second. **AD-142: \$142**

12 Bit A to D: Analog to digital converter. Input range -4V to +4V, expandable to 100V. On-board amplifier. Resolution 1mV. Conversion time 130ms. 1 channel. (Expand to 8 channels with the RE-156 card.) **AN-146: \$153**

Relay Card: 8 individually controlled industrial relays each with status LED's (3A at 120VAC contacts, SPST). **RE-140: \$142**

Reed Relay Card: 8 reed relays (20mA at 60VDC, SPST). Individually controlled and latched, with status LEDs. **RE-156: \$109**

D/A converter: 4 Channel 8 Bit D/A converter with output amplifiers and separate adjustable references. **DA-147: \$149**

24 line TTL I/O: Connect 24 input or output signals (TTL 0/5V levels or switches). Variety of modes. (Uses 8255A) **DG-148: \$72**

Digital Input: 8 optically isolated inputs. Input can be 5 to 100V voltage levels or switch closures. **IN-141: \$65**

Digital Output Driver: 8 outputs: 250mA at 12V. Drive relays, solenoids, stepper motors, lamps, etc. **ST-143: \$78**

Clock with Alarm: Powerful clock/calendar. Battery backup. Timing to 1/100 sec. Alarm relay, LED and buzzer. **CL-144: \$98**

Touch Tone Decoder: Each tone is converted into a number which is stored on the board. **PH-145: \$87**

A-BUS Prototyping card: 4x4.5" card. Will accept up to 10 I.C.s. With power & ground bus. **PR-152: \$116**

Counter Timer: Three 16 bit counters/timers. Use separately or cascade for long (48 bit) counts. **CT-150: \$132**

Call our application engineers to discuss your project.

Motion Control

Smart Quad Stepper Controller: The world's finest.

On board microprocessor controls four motors simultaneously. Uses simple English commands like "MOVE ARM 10.2 (INCHES) LEFT". For each axis, you control coordinates (absolute or relative), ramping, speed, units, scale factors, etc. Many inputs for limit switches, etc. On the fly reporting of speed, position... Built in drivers for small motors (such as MO-103 or 105). **SC-149: \$299**
Options: ▶ 5 amp/phase power booster for 1 motor. **PD-123: \$49**
▶ Remote "teach" keypad for direct motor control: **RC-121: \$54**

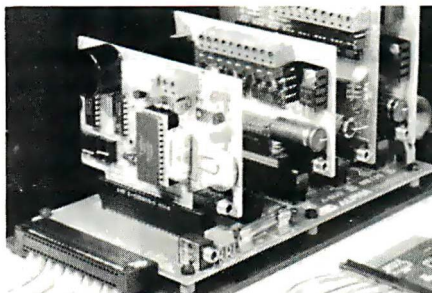

A large A-BUS system with two Motherboards Adapter in the foreground plugs into PC XT, AT type slot.

Stepper Driver Kit: For experimenting with stepper motors. Includes 2 MO-103 motors and a ST-143 dual driver **PA-181: \$99**

Stepper Motors: (4 phase, unipolar)
MO-103: 2 1/4" dia, 1/4" shaft, 7.5°/step, 12V, 5 oz-in torque. **\$15**
MO-104: 2" dia, 1/4" shaft, 1.8°/step, 5V, 60 oz-in torque. **\$45**
MO-105: 1.7" square, .2" shaft, 3.75°/step, 12V, 6 oz-in. **\$15**

A-BUS Adapters

▶ Can address 64 ports and control up to 25 A-BUS cards.
▶ Require one cable. Motherboard required for more than 2 cards.

A-BUS Parallel Adapters for:

IBM PC/XT/AT & compatibles. Uses one short or long slot. **AR-133: \$69**
Apple II, II+, IIe Plugs into any slot inside. **AR-134: \$52**
Commodore 64, 128 Plugs into Expansion Port on back. **AR-139: \$48**
TRS-80 Model 102, 200 Uses 40 pin "System bus". **AR-136: \$76**
Model 100 (Tandy portable) Plugs into socket on bottom. **AR-135: \$75**
TRS-80 Model 3, 4, 4D Y-Cable available if 50 pin bus is used. **AR-132: \$54**
TRS-80 Model I Plugs into 40 pin expansion bus. **AR-131: \$39**
Tandy Color Computers Fits ROM slot, Multispak or Y-Cable **AR-138: \$49**

A-BUS Cable: Necessary to connect any parallel adapter to one A-BUS card or to first motherboard. 50 pin, 3 ft. **CA-163: \$24**
Special Cable for two A-BUS cards **CA-162: \$34**

Serial Adapter: Connect A-BUS systems to any RS-232 port. Allows up to 500 ft from computer to A-BUS. **SA-129: \$149**

Serial Node: To connect additional SA-129/A-BUS systems to a single RS232 serial port (max 16 nodes). **SN-128: \$49**

Serial Processor: same as above plus built in BASIC for off-line monitoring, logging, decision making, etc. **SP-127: \$189**
Use SA-129 or SP-127 with modems for remote data acquisition.

Motherboard: Holds up to 5 A-BUS cards in sturdy aluminum frame with card guides. A sixth connector allows (using cables CA-161: \$12) additional Motherboards to be added. **MB-120: \$108**

Power Supply: Power pack for up to 4 cards. **PS-126: \$12**

Complete Catalog Available

For Orders and Info call (203) 656-1806

Weekdays from 9 to 5 EST or FAX 203 656-0756

Ordering Information: We accept Visa, Mastercard, Checks, and M.O. C.O.D. is \$4 extra. Purchase orders are subject to credit approval. CT residents add 7.5% sales tax. Shipping: \$4 per order (usually UPS ground). UPS 2nd Day Air: \$4 extra. Next Day service available. Canada: \$6 per order (Airmail). Outside US and Canada: Add 10% of order total.

Circle 19 on Reader Service Card



a Sigma Industries Company

ALPHA Products

242-B West Avenue, Darien, CT 06820

APRIL 1989 • BYTE 349

POWER SUPPLIES



135 WATT POWER SUPPLY

- UL APPROVED
- +5V @ 15A, +12V @ 4.2A, -5V @ 5A, -12V @ .5A

PS-135 \$59.95



200 WATT POWER SUPPLY

- UL APPROVED
- +5V @ 20A, +12V @ 7A, -5V @ .5A, -12V @ .5A

PS-200 \$89.95



APPLE TYPE SUPPLY

- WITH APPLE CONNECTOR
- +5V @ 6A, +12V @ 3A, -5V @ 1A, -12V @ 1A

PS-A \$49.95



36 WATT POWER SUPPLY

- +5V @ 2.5A, +12V @ 1.5A
- 3 PIN INPUT, 6 PIN OUTPUT
- SELECTABLE 110V-220V

PS-3045 \$12.95



SOLDER STATIONS

SOLDER/DESOLDER STATION

- OIL-FREE VACUUM PUMP
- TEMP ADJUSTS (212° F-900° F) & VACUUM (0-60 CM/HG)
- WITH GUN-REST, COOLING TRAY, WIRE BRUSH & TIP CLEANER ROD
- XY999SD \$399.95
- XY999D DESOLDER ONLY \$349.99



DELUXE SOLDER STATION

- ROTARY SWITCH TEMP CONTROL (200° F-878° F RANGE)
- LED TEMPERATURE READOUTS
- INCLUDES COOLING TRAY
- XY9-60L \$79.95



SOLDER STATION

- UL APPROVED
- HEAT SETTING ADJUSTS
- TIP TEMPERATURE READOUT
- REPLACEMENT TIPS @ \$2.95
- 168-3C \$59.95

WIREWAP PROTOTYPE CARDS

FR-4 EPOXY GLASS LAMINATE WITH GOLD PLATED EDGECARD FINGERS AND SILK SCREENED LEGENDS



FOR XT
JDR-PR1 WITH +5V AND GROUND PLANE \$27.95
JDR-PR2 ABOVE WITH I/O DECODING LAYOUT \$29.95

FOR AT
JDR-PR10 16 BIT WITH I/O DECODING LAYOUT \$34.95
JDR-PR10PK PARTS KIT FOR JDR-PR10 ABOVE \$12.95

FOR PS/2
JDR-PR32 32 BIT PROTOTYPE CARD \$69.95
JDR-PR16 16 BIT WITH I/O DECODING LAYOUT \$49.95
JDR-PR16PK PARTS KIT FOR JDR-PR16 ABOVE \$15.95
JDR-PR16V 16 BIT FOR VIDEO APPLICATIONS \$39.95

JDR INSTRUMENTS—2 YEAR WARRANTY!

35 MHZ DUAL TRACE OSCILLOSCOPE

- WIDE BAND WIDTH ■ VARIABLE HOFF
- MODEL-3500 (SHOWN) \$499.95

20 MHZ DUAL TRACE OSCILLOSCOPE

- TV SYNC FILTER ■ COMPONENTS TESTER
- MODEL 2000 \$389.95

3.5 DIGIT PROBE TYPE DMM

- AUTORANGING ■ AC/DC 2V - 500V, RESIS. 2K-2M
- DPM-1000 (SHOWN) \$54.95

3.5 DIGIT POCKET SIZE DMM

- BASIC DC ACCURACY ±0.5% ■ 14 RANGES
- DMM-100 \$29.95

3.5 DIGIT FULL FUNCTION DMM

- BASIC DC ACCURACY ±0.25% ■ 22 RANGES
- DMM-200 \$49.95

THE ULTIMATE 3.5 DIGIT DMM

- BASIC DC ACCURACY ±0.25% ■ 34 RANGES
- TEMP, TRANSISTOR & RESISTANCE FEATURES
- DMM-300 (SHOWN) \$79.95

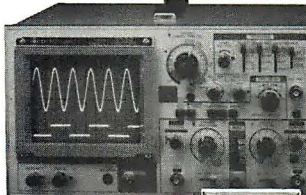

RELIABLE, HIGH QUALITY TEST EQUIPMENT, REASONABLY PRICED

DATA SWITCH BOXES

TYPE	# OF POS.	PARALL.	SERIAL	PRICE
PUSHBTN.	2-WAY	AB-P	AB-S	39.95
ROTARY	2-WAY	RSP-2	RSS-2	24.95
ROTARY	3-WAY	RSP-3	RSS-3	27.95
ROTARY	4-WAY	RSP-4	RSS-4	29.95

COMPUTER CABLES

GOLD-PLATED CONTACTS; 100% SHIELDED

CBL-PRINTER	PC PRINTER CABLE	9.95
CBL-PRINTER-25	AS ABOVE-25 FT.	15.95
CBL-PRINTER-RA	RT. ANGL. PRINTER	15.95
CBL-DB25-MM	DB25 MALE-MALE	9.95
CBL-DB25-MF	DB25 MALE-FEMALE	9.95
CBL-9-SERIAL	9 PIN-25 PIN SERIAL	6.95
CBL-KBD-EXT	KEYBOARD EXTEN.	7.95
CBL-CNT-MM	36 PIN CENTRON-MM	14.95
CBL-HD-20	20 PIN HARD DISK	3.95
CBL-HD-34D	34 PIN DUAL HARD DISK	6.95
CBL-FDC-EXT	37 PIN EXT. FLOPPY	9.95
CBL-MNT-9	9 PIN MONITOR EXTEN.	6.95
CBL-MODEM	DB25-DB25 FEMALE	7.95

EXTENDER CARDS

FOR PROTOTYPE DEBUGGING, TESTING AND TROUBLESHOOTING

EXT-8088 XT COMPATIBLE \$29.95
EXT-80286 AT COMPATIBLE \$39.95
EXT-16 MICROCHANNEL 16-BIT \$69.95
EXT-32 MICROCHANNEL 32-BIT \$99.95



NEW LOW PRICES! SOLDERLESS BREADBOARDS

PDS-100	1360 TIE PTS	\$12.95
PDS-200	1660 TIE PTS	\$19.95
PDS-300	2370 TIE PTS	\$24.95
PDS-400	3220 TIE PTS	\$34.95

IDC CONNECTORS/RIBBON CABLE

DESCRIPTION	ORDER BY	CONTACTS					
		10	20	26	34	40	50
SOLDER HEADER	IDHxxS	.82	1.29	1.68	2.20	2.58	3.24
RIGHT ANGLE SOLDER HEADER	IDHxxSR	.85	1.35	1.76	2.31	2.72	3.39
WIREWAP HEADER	IDHxxW	1.86	2.98	3.84	4.50	5.28	6.63
RIGHT ANGLE WIREWAP HEADER	IDHxxWR	2.05	3.28	4.22	4.45	4.80	3.70
RIBBON HEADER SOCKET	IDSxx	.63	.89	.95	1.29	1.49	1.69
RIBBON HEADER	IDMxx	--	5.50	6.25	7.00	7.50	8.50
RIBBON EDGE CARD	IDExx	.85	1.25	1.35	1.75	2.05	2.45
10' RIBBON CABLE	RCxx	1.60	3.20	4.10	5.40	6.40	7.50

FOR ORDERING INSTRUCTIONS, SEE D-SUBMINIATURE CONNECTORS BELOW

D-SUBMINIATURE CONNECTORS

DESCRIPTION	ORDER BY	CONTACTS						
		9	15	19	25	37	50	
SOLDER CUP	MALE	DBxxP	.45	.59	.69	.69	1.35	1.85
	FEMALE	DBxxS	.49	.69	.75	.75	1.39	2.29
RIGHT ANGLE PC SOLDER	MALE	DBxxPR	.49	.69	--	.79	2.27	--
	FEMALE	DBxxSR	.55	.75	--	.85	2.49	--
WIREWAP	MALE	DBxxPWW	1.69	2.56	--	3.89	5.60	--
	FEMALE	DBxxSWW	2.76	4.27	--	6.84	9.95	--
IDC RIBBON CABLE	MALE	IDBxxP	1.39	1.99	--	2.25	4.25	--
	FEMALE	IDBxxS	1.45	2.05	--	2.35	4.49	--
HOODS	METAL	MHOODxx	1.05	1.15	1.25	1.25	--	--
	PLASTIC	HOODxx	.39	.39	--	.39	.69	.75

ORDERING INSTRUCTIONS: INSERT THE NUMBER OF CONTACTS IN THE POSITION MARKED "xx" OF THE "ORDER BY" PART NUMBER LISTED. EXAMPLE: A 15 PIN RIGHT ANGLE MALE PC SOLDER WOULD BE DB15PR MOUNTING HARDWARE .59

IC SOCKETS/DIP CONNECTORS

DESCRIPTION	ORDER BY	CONTACTS									
		8	14	16	18	20	22	24	28	40	
SOLDERTAIL SOCKETS	xxST	.11	.11	.12	.15	.18	.15	.20	.22	.30	
WIREWAP SOCKETS	xxWW	.59	.69	.69	.99	1.09	1.39	1.49	1.69	1.99	
ZIF SOCKETS	ZIFxx	--	4.95	4.95	--	5.95	--	5.95	6.95	9.95	
TOOLED SOCKETS	AUGATxxST	.62	.79	.89	1.09	1.29	1.39	1.49	1.69	2.49	
TOOLED WW SOCKETS	AUGATxxWW	1.30	1.80	2.10	2.40	2.50	2.90	3.15	3.70	5.40	
COMPONENT CARRIERS	ICCCxx	.49	.59	.69	.99	.99	.99	.99	1.09	1.49	
DIP PLUGS (IDC)	IDPxx	.95	.49	.59	1.29	1.49	--	.85	1.49	1.59	

FOR ORDERING INSTRUCTIONS SEE D-SUBMINIATURE CONNECTORS ABOVE

LITHIUM BATTERY

- 6V FOR 286 AND 386 PCS
- MOTHERBOARD CONNECTOR
- ADHESIVE VELCRO MOUNTING STRIP
- LITHIUM 6.8V \$11.95

COIN TYPE BATTERY

- LONG-LASTING 3V LITHIUM
- 3V-MHW \$1.95
- HOLDER \$1.49

APPLE-COMPATIBLE PRODUCTS

- FLOPPY DRIVE FOR APPLE II SERIES AP-150 (W/CABLE, CONNECTOR) \$99.95
- REPLACEMENT KEYBOARD FOR APPLE II & II+ KEYBOARD-AP \$59.95
- EPROM PROGRAMMER, NOT REC. FOR CMOS, RP-525 (NO POWER SUPPLY REQ.) \$89.95
- 16K RAM CARD BOOSTS 48K APPLE TO 64K RAM-CARD (2 YEAR WARRANTY) \$39.95

GENDER CHANGERS

- GENDER-FF FEMALE-FEMALE \$7.95
- GENDER-MM MALE-MALE \$7.95
- GENDER-MF MALE-FEMALE \$7.95
- GENDER-NM NULL/MODEM \$8.95
- GENDER-JB JUMPER BOX \$8.95
- GENDER-MT MINITESTER \$14.95
- GENDER-VGA DB9-DB15 \$19.95
- GENDER-9-25 DB9-DB25 \$4.95

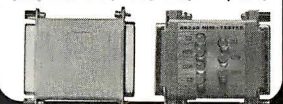

"SNAPABLE HEADERS"

- SNAP APART TO MAKE ANY SIZE HEADER, WITH .1" CENTERS
- | | | |
|--------|------------------|--------|
| 1 X 40 | STRAIGHT LEAD | .99 |
| 1 X 40 | RIGHT ANGLE LEAD | \$1.49 |
| 2 X 40 | STRAIGHT LEAD | \$2.49 |
| 2 X 40 | RIGHT ANGLE LEAD | \$2.99 |



JDR MICRODEVICES, 2233 BRANHAM LANE, SAN JOSE, CA 95124
LOCAL (408) 866-6200 FAX (408) 559-0250 TELEX 171-110
RETAIL STORE: 1256 S. BASCOM AVE., SAN JOSE, CA
(408) 947-8881 HOURS: M-F, 9-7 SAT. 9-5 SUN. 12-4

NEW ADDRESS!

Terms: Minimum order \$10.00. For shipping & handling include \$3.50 for ground and \$4.50 for air. Orders over 1 lb and foreign orders may require additional shipping charges—contact the sales department for the amount. CA residents must include applicable sales tax. Prices subject to change without notice. We are not responsible for typographical errors. We reserve the right to limit quantities and to substitute manufacturer. All merchandise subject to prior sales. A full copy of our terms is available upon request. Items pictured may only be representative.

ORDER TOLL FREE 800-538-5000

COPYRIGHT 1989 JDR MICRODEVICES

CONTINENTAL U.S.

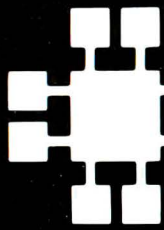

JDR Microdevices

MMC
MICROCOMPUTER
MARKETING COUNCIL
of the Direct Marketing Association, Inc.

• 30 DAY MONEY BACK GUARANTEE • 1 YEAR WARRANTY ON ALL PRODUCTS • TOLL-FREE TECHNICAL SUPPORT
• COMPLETE CUSTOMER SATISFACTION • SUPERIOR SERVICE • FRIENDLY, KNOWLEDGEABLE SALES STAFF



2400 BAUD MODEM

\$129.95

- HAYES COMPATIBILITY ■ 1/2-CARD ■ AUTO DIAL/ANSWER
- SELF-TEST ON POWER UP ■ FULL AND HALF DUPLEX
- TOUCH-TONE OR PULSE DIALING ■ 2ND PHONE JACK
- CALL PROGRESS MONITORING ■ ADJUSTABLE VOLUME

INTERNAL MODEMS (MIRROR II SOFTWARE INCLUDED)
 PRO-121 1200 BAUD 1/2 CARD \$69.95
 PRO-24M 2400 BAUD FOR PS/2 \$249.95

EXTERNAL MODEMS REQ. SERIAL PT., CABLE, SOFTWARE
 PRO-24E 2400 BAUD \$169.95
 PRO-12E 1200 BAUD \$99.95

APPLE/MACINTOSH COMPATIBLE MODEMS
 EXTERNAL MODEMS, AS ABOVE WITH CABLE & SOFTWARE
 PRO-24EM MAC 2400 BAUD \$199.95
 PRO-24A APPLE II 2400 BAUD \$179.95
 PRO-12A APPLE II 1200 BAUD \$139.95



VGA COMPATIBLE PACKAGE

\$649

- 800 X 560 MAXIMUM RESOLUTION
- 640 X 480 IN 16 COLORS
- 320 X 200 N 256 COLORS
- IBM STYLE MONITOR
- VGA, EGA, CGA, HERCULES, MONOCHROME COMPATIBLE
- VGA-PKG (INCLUDES ATI CARD AND MONITOR)



NEC MULTISYNC II \$599.95
 ■ AUTO FREQ. ADJUSTMENT ■ RESOLUTION TO 800 X 560
 ■ IDEAL FOR CAD, CAM, WINDOWS ■ 9-15 PIN ADAPTER
 NEC-MULTI

JDR MULTI \$499.95
 ■ FULL FEATURED MULTISYNC MONITOR WITH UNLIMITED COLORS ■ HIGH RESOLUTION, 14" NON-GLARE DISPLAY
 ■ AUTO SWITCHING ■ TTL/ANALOG VIDEO INPUT
JDR-MULTI
 JDR-MONO 12" MONOCHROME MONITOR \$69.95

EGA MONITOR \$399.95
 ■ 640 X 200/350 RESOLUTION ■ 16 COLOR DISPLAY ■ 31MM DOT PITCH ■ 14" BLACK MATRIX SCREEN ■ 9-PIN CABLE
EGA-MONITOR

SAVE \$50! EGA CARD & MONITOR \$499

RGB MONITOR \$279.95
 ■ COLOR/GREEN/AMBER SWITCH ■ 41MM DOT PITCH
 ■ 640X200 MONOCHROME RESOLUTION ■ 14" NON-GLARE SCREEN ■ TILT AND SWIVEL BASE
RGB-MONITOR

FLAT SCREEN \$139.95
 ■ LOW DISTORTION, 14" GLARE-RESISTANT AMBER SCREEN
 ■ 720 X 350 MAXIMUM RESOLUTION ■ IBM COMPATIBLE TTL INPUT ■ SWIVEL BASE
GM-1488
 MONO-SAMSUNG WITH 12" SCREEN \$129.95

TILT & SWIVEL MONITOR STANDS
 MS-100 DURABLE PLASTIC \$12.95
 MS-200 WITH 5 OUTLETS & SURGE SUPPRESSOR \$39.95

HIGH QUALITY KEYBOARDS

101 KEY ENHANCED, W/SEPARATE CURSOR PAD:
 BTC-5339 AUTOSENSE FOR XT/ AT, AUTOREPEAT \$79.95
 K103-A AUDIBLE "CLICK" STYLE \$84.95
 MAX-5339 MAXI-SWITCH W/TACTILE FEEDBACK \$84.95



84 KEY STYLE:
 BTC-5060 AUTOSENSE FOR XT/AT \$59.95
 MAX-5060 MAXI-SWITCH W/TACTILE FEEDBACK \$64.95

20 MB \$269
30 MB \$299



KITS INCLUDE A SEAGATE HARD DISK DRIVE, DRIVE CONTROLLER, CABLES AND INSTRUCTIONS.
HDKIT20 20 MB SYSTEM KIT
HDKIT30 30 MB SYSTEM KIT



FAST, RELIABLE SEAGATE HARD DISKS:

DISK SIZE	MODEL	AVG. SPD.	SIZE	PRICE
20MB	ST-125	65 MS	3-1/2"	\$259
20MB	ST-225	65 MS	5-1/4"	\$225
30MB RLL	ST-238	65 MS	5-1/4"	\$249
40MB	ST-251	40 MS	5-1/4"	\$379
40MB	ST-251-1	28 MS	5-1/4"	\$469
60MB RLL	ST-277	40 MS	5-1/4"	\$449
80MB	ST-4096	28 MS	5-1/4"	\$629

1 Mb 3 1/2" DRIVE

\$99.95

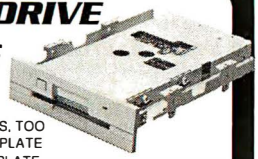

- ULTRA HIGH DENSITY
- READ/WRITE 720K DISKS, TOO
- FDD-1.44X BLACK FACEPLATE
- FDD-1.44A BEIGE FACEPLATE
- FDD-1.44 SOFT SPOFFWARE DRIVER \$19.95

1/2 HEIGHT FLOPPY DISK DRIVES:
 FD-55B 5-1/4" TEAC DS/DD 360K \$99.95
 FD-55G 5-1/4" TEAC DS/HD 1.2M \$129.95
 FDD-360 5-1/4" DS/DD 360K \$69.95
 FDD-1.2 5-1/4" DS/HD 1.2M \$109.95
 FDD-3.5X 3-1/2" 720K (BLACK) \$97.95
 FDD-3.5A 3-1/2" 720K (BEIGE) \$97.95

NASHUA DISKETTES (BOXES OF 10):
 N-MD2D 360K DS/DD \$6.95
 N-MD2D BULK (MULTIPLIES OF 50 DISKS) EACH .49
 N-MD2H 1.2 MB DS/HD \$13.95
 N-3.5HD 1.44 MB 3-1/2" DS/HD \$49.95
 N-3.5DS 720K 3-1/2" DD/DS \$16.95

TAPE BACK-UP DRIVES & DRIVE ACCESSORIES:
 AR5240X ARCHIVE DRIVE XT'S & AT'S \$369.95
 AR5540A FASTER DRIVE--AT'S ONLY \$369.95
 AR340 40 MB TAPE CARTRIDGES \$24.95

FD-ARAIL MTG. RAILS FOR AT COMPATIBLE \$2.95
 FD-55MHW HALF-HT. MOUNTING HARDWARE \$2.95
 FD-5Y Y-POWER ADAPTOR FOR DRIVES \$2.95
 FD55P BEIGE FACEPLATE FOR TEAC DRIVES \$2.95

MOTHERBOARDS

NEW LOW PRICES!

TURBO 4.77/8 MHZ \$95.95
 ■ XT COMPATIBLE ■ NORTON SI 1.7 ■ 4.77 OR 8 MHZ WITH 8088-2 AND OPTIONAL 8087-2 CO-PROCESSOR
MCT-TURBO
 MCT-XMB STANDARD. 8088 MOTHERBOARD \$87.95

10 MHZ SINGLE CHIP \$99.95
 ■ XT COMPATIBLE ■ NORTON SI 2.1 ■ USES LESS POWER ■ KEY-SELECTABLE 4.77 OR 10 MHZ
MCT-TURBO-10

10 MHZ MINI-286 \$299.95
 ■ AT COMPATIBLE ■ ONLY 8-1/2 X 13" ■ 80286 MICRO-PROCESSOR ■ LANDMARK AT SPEED 15.5 MHZ, NORTON SI 13.8 ■ 6.10 MHZ; KEYBOARD SELECT
MCT-M286

12 MHZ MINI-286 \$339.95
 ■ AT COMPATIBLE ■ ONLY 8-1/2 X 13" ■ 80286 MICRO-PROCESSOR ■ LANDMARK AT SPEED 15.5 MHZ, NORTON SI 13.8 ■ 6.10, 12 MHZ; KEYBOARD SELECT ■ ZYMO'S POACH CHIP SET ■ AWARD BIOS
MCT-M286-12

EPROM PROGRAMMER \$129.95

■ PROGRAMS 27XX AND 27XXX EPROMS UP TO 27512
 ■ SUPPORTS VARIOUS PROGRAMMING FORMATS & VOLTAGES ■ SPLIT OR COMBINE CONTENTS OF SEVERAL EPROMS OF DIFFERENT SIZES
 ■ READ, WRITE, COPY, ERASE, CHECK & VERIFY
 ■ SOFTWARE FOR HEX AND INTEL HEX FORMATS
MOD-EPROM



L GITECH HIREZ MOUSE

\$89.95

HIGH RESOLUTION BUS MOUSE FOR BETTER RESPONSE, LESS MOVEMENT
 ■ 320 DPI ■ WITH DRIVER, TEXT EDITOR & POP-UP MENUS ■ NO PAD POWER SUPPLY OR PORT REQUIRED
LMOUSE-BH

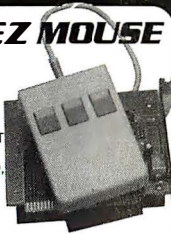

LOGITECH 3 BUTTON MOUSE
 PC MAGAZINE EDITORS' CHOICE! ALL MODELS HAVE SERIAL SUPPORT (COM1/COM2), 200 D.P.I. RESOLUTION, LOTUS 1-2-3 SHELL, SELF-INSTALLING SOFTWARE AND "POINT EDITOR"
LMOUSE \$74.95
LMOUSE-P SERIAL MOUSE W/LOGIPAIN \$89.95
LMOUSE-BP BUS MOUSE W/LOGIPAIN \$89.95
LMOUSE-BPBL BUS MOUSE W/PUBLISHER PKG \$129.95
LMOUSE-BPC BUS MOUSE W/LOGIPAIN/CAD \$139.95

MODULAR PROGRAMMING SYSTEM

OUR INTEGRATED MODULAR PROGRAMMING SYSTEM EASILY EXPANDS! ALL THE MODULES USE A COMMON HOST ADAPTOR CARD, SO YOU CAN USE JUST ONE SLOT TO PROGRAM EPROMS, PROMS, PALS & MORE!

HOST ADAPTOR CARD \$29.95

- UNIVERSAL INTERFACE FOR ALL THE PROGRAMMING MODULES!
- SELECTABLE ADDRESSES PREVENTS CONFLICTS
- HIGH QUALITY MOLDED CABLE

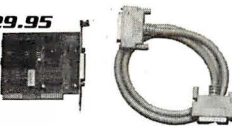

UNIVERSAL MODULE \$499.95

- PROGRAMS EPROMS, EEPROMS, PALS, BI-POLAR PROMS, 8748 & 8751 SERIES DEVICES, 16V8 & 20V8 GALS (GENERIC ARRAY LOGIC) FROM LATTICE, NS, SGS
- TESTS TTL, CMOS, DYNAMIC & STATIC RAMS ■ LOAD DISK, SAVE DISK, EDIT, BLANK CHECK, PROGRAM, AUTO, READ MASTER, VERIFY & COMPARE
- TEXT/OOL SOCKET FOR .3" TO .6" W. IC'S (8-40 PINS)



EPROM MODULE \$119.95

- PROGRAMS 24-32 PIN EPROMS, CMOS EPROMS & EEPROMS FROM 16K TO 1024K ■ HEX TO OBJ CONVERTER ■ AUTO, BLANK CHECK/PROGRAM/VERIFY ■ VPP 5, 12.5, 12.75, 13, 21 & 25 VOLTS
- NORMAL, INTELLIGENT, INTERACTIVE, & QUICK PULSE PROGRAMMING ALGORITHMS

MOD-MEP
 MOD-MEP-4 4-EPROM PROGRAMMER \$169.95
 MOD-MEP-8 8-EPROM PROGRAMMER \$259.95
 MOD-MEP-16 16-EPROM PROGRAMMER \$499.95

DIGITAL IC MODULE \$129.95

- TESTS TTL, CMOS, DYNAMIC & STATIC RAM
- AUTO SEARCH FOR UNKNOWN PART NUMBERS
- USER-PROGRAMMABLE TEST PROCEDURES

PAL MODULE \$249.95

- PROGRAMS MMI, NS, TI 20 & TI 24 PIN DEVICES
- BLANK CHECK, PROGRAM, AUTO, READMASTER, VERIFY & SECURITY FUSE BLOW

MOD-MPL
 PAL PROGRAMMING DEVELOPMENT SOFTWARE \$99.95
MOD-MPL-SOFT

DFI HANDY SCANNER

\$249.95

- INSTANTLY SCANS UP TO 4.1" W. IMAGES
- 100, 200, 300, 400 DPI BOTH DIRECTIONS
- B&W & 3 HALF-TONE MODES
- 32 LEVELS OF GRAY SCALE
- HERCULES, CGA, EGA & VGA COMPATIBLE
- INCLUDES HALO DPE AND IMAGE EDITOR SOFTWARE
- HS-3000



400
DPI

OCR-SOFT SOFTWARE \$99.95

BUILD YOUR OWN SYSTEM!

OVER 25,000 JDR SYSTEMS HAVE BEEN BUILT.

OUR DETAILED INSTRUCTIONS MAKE IT VERY EASY—ALL YOU NEED IS ABOUT 2 HOURS AND A SCREWDRIVER!



VIDEO INSTRUCTIONS \$4.95 WITH SYSTEM
OUR 20 MINUTE VIDEO SHOWS YOU STEP-BY-STEP HOW TO BUILD AN XT-COMPATIBLE SYSTEM. SPECIFY VHS OR BETA. VIDEO WITH SYSTEM KIT, \$4.95 VIDEO ALONE, 19.95

10 MHz TURBO 8088 SYSTEM \$636.20

- SERIAL/PARALLEL PORTS, CLOCK/CALENDAR & GAME ADAPTOR
- RUNS COLOR GRAPHICS SOFTWARE ON ITS MONOCHROME MONITOR
- MOTHERBOARD
- 256K RAM MEMORY
- 135W POWER SUPPLY
- FLOPPY CASE
- 84 KEY KEYBOARD
- 360K FLOPPY DRIVE
- MONOGRAPHICS I/O CARD

12 MHz MINI-286 SYSTEM \$1152.70

- 12 MHz MINI-286 MOTHERBOARD
- 512K RAM MEMORY
- MINI-AT CASE POWER SUPPLY
- 84 KEY KEYBOARD
- MONOCHROME MONITOR
- 1.2 MB FLOPPY DRIVE
- FLOPPY/HARD CONTROL
- MONOGRAPHICS CARD

EPSON PRICES SO LOW, WE CAN'T PRINT THEM!

JDR CARRIES A FULL LINE OF QUALITY EPSON PRINTERS. WE CAN'T ADVERTISE OUR LOW PRICES—CALL OUR SALES DEPARTMENT FOR A PRICE QUOTE TODAY: 1-800-538-5000 TOLL-FREE!

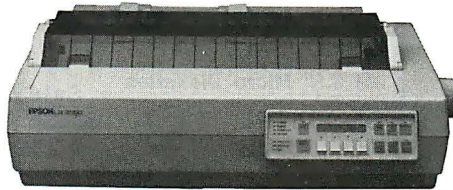

EPSON LQ-2550 CALL FOR THE PRICE!

- 132-COLUMN CARRIAGE, SUPER FAST OUTPUT!
- 24-PIN PRINT HEAD; 8K MEMORY BUFFER
- 400 CPS DRAFT, 133 CPS LQ
- PRINTS UP TO 7 COLORS
- SEVEN FONTS
- PARALLEL & SERIAL INTERFACES

EPSON LQ-950 CALL FOR THE PRICE!

- 24-PIN PRINT HEAD; 6K MEMORY BUFFER
- 110-COL. CARRIAGE
- 264 CPS DRAFT, 88 CPS LQ
- 360 X 360 DPI GRAPHICS RESOL.
- PARALLEL AND SERIAL INTERFACES

EPSON LQ-850 CALL FOR THE PRICE!

- 24-PIN PRINT HEAD; 6K MEMORY BUFFER
- 80-COL. CARRIAGE
- 264 CPS DRAFT, 88 CPS LQ
- BIDIRECTIONAL TEXT & GRAPHICS
- PARALLEL AND SERIAL INTERFACES

EPSON LQ-500 CALL FOR THE PRICE!

- 24-PIN PRINT HEAD; 8K MEMORY BUFFER
- 80-COL. CARRIAGE
- 180 CPS DRAFT, 60 CPS LQ
- BIDIRECTIONAL TEXT & GRAPHICS
- PARALLEL INTERFACE (SERIAL OPT.)

EPSON FX-850 CALL FOR THE PRICE!

- FOR FORMS, ENVELOPES, FANFOLDS!
- 80-COL. CARRIAGE
- 264 CPS DRAFT, 54 CPS NLO
- 9-PIN PRINT HEAD; 8K MEMORY BUFFER
- AUTOLOAD
- PARALLEL INTERFACE
- FX-1050 WITH 136-COLUMN CARRIAGE \$CALL!

EPSON FX-800 CALL FOR THE PRICE!

- 9-PIN PRINT HEAD; 8K MEMORY BUFFER
- 80-COLUMN CARRIAGE
- 300 CPS DRAFT, 50 CPS NLO
- BIDIRECTIONAL TEXT MODE
- PARALLEL & SERIAL INTERFACES

EPSON LX-800 CALL FOR THE PRICE!

- 9-PIN DOT MATRIX PRINT HEAD; 3K MEMORY BUFFER
- 80-COL. CARRIAGE
- 180 CPS DRAFT, 30 CPS NLO MODE
- PARALLEL INTERFACE (SERIAL OPTIONAL.)

24-HR. ON-LINE ORDERING!

(408) 559-0253

JDR'S ELECTRONIC BULLETIN BOARD OFFERS TECHNICAL SUPPORT, CONFERENCING AND MORE

DEAR JDR MICRODEVICES:

"AS LONG AS YOU HAVE PEOPLE OF THE QUALITY AND HIGH CALIBER STANDARDS THAT BRENDA AND BOB EXEMPLIFY, YOU WILL HAVE NO PROBLEM MAINTAINING YOUR GOAL OF 100% CUSTOMER SATISFACTION."
—N.L. DIMARCO, BLOOMSBURY, NJ

BARGAIN HUNTERS' CORNER
SAVE \$40
20 MHz DUAL-TRACE OSCILLOSCOPE
\$349.95

REGULARLY \$389.95
FAST FREQUENCY AND PHASE MEASUREMENT
TV SYNC CIRCUITS TO VIEW TV-V AND TV-H
ACCURATE SYNCHRONIZATION OF VIDEO SIGNAL, BLANKING, VITS, AND V/H SYNC PULSES
COMPONENT TESTER
BRIGHT 5-INCH CRT
X-Y OPERATION 110/120V
2 YEAR WARRANTY
MODEL 2000 OFFER EXPIRES 5/31/89

INTERFACE CARDS MODULAR CIRCUIT TECHNOLOGY

DISPLAY ADAPTORS

MONOCHROME GRAPHICS \$59.95
HERCULES COMPAT. SUPPORTS LOTUS 1-2-3 ■ VLSI CHIPS ■ PARALLEL PRINTER PORT CONFIG. AS LPT1 OR 2
MCT-MGP

COLOR GRAPHICS ADAPTOR \$49.95
IBM COMPATIBLE ■ FOR RGB, COLOR AND COMPOSITE MONO ■ 640/320 X 200 RESOLUTION WITH LIGHT PEN
INTERFACE
MCT-CG

ENHANCED GRAPHICS ADAPTOR \$149.95
IBM COMPATIBLE, PASSES IBM EGA DIAGNOSTICS
256K OF VIDEO RAM FOR 640 X 350 IN 16 OF 64 COLORS
HERCULES COMPATIBLE
MCT-EGA

MONOGRAPHICS MULTI I/O \$119.75
CONTROL 2 FLOPPIES, SERIAL, PARALLEL, GAME PORT, CAL CLOCK ■ RUN COLOR GRAPHICS SOFTWARE ON YOUR MONOCHROME MONITOR
MCT-MGMIO

286/386 MONOGRAPHICS I/O \$99.95
HOOK UP A MONOCHROME MONITOR, PARALLEL PRINTER, MODEM AND JOYSTICK ALL AT ONCE! ■ ONLY OTHER CARD YOUR SYSTEM NEEDS IS A FLOPPY/HARD CONTROLLER ■ AT COMPATIBLE ■ 720 X348 RESOLUTION, 80 & 132 COLUMN TEXT ■ PARALLEL, SERIAL AND GAME PORTS ■ HERCULES COMPATIBLE MONOGRAPHICS ■ WITH SOFTWARE TO RUN COLOR GRAPHICS ON A MONOCHROME MONITOR
MCT-MGAIO

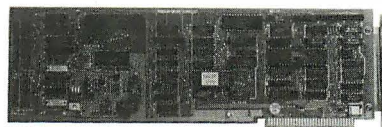
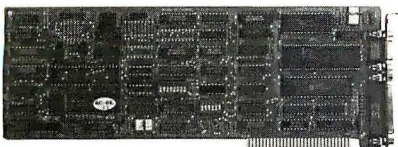

DRIVE CONTROLLERS

FLOPPY/HARD CONTROLLER \$139.95
FREES 1 SLOT IN YOUR XT SYSTEM ■ INTERFACES 2 FDD'S AND 2 HDD'S, CABLING FOR 2 FDD, 1 HDD
MCT-FH (SHOWN)

FLOPPY DISK CONTROLLER \$29.95
1 SLOT CONTROL OF 4 FLOPPIES ■ INTERFACES UP TO 4 FDD'S TO IBM PC OR COMPATIBLE ■ DS/DD & DS/QD
MCT-FDC

1.2 MB FLOPPY CONTROLLER \$69.95
SUPPORTS 2 DRIVES, CAN MIX 360K AND 1.2MB ■ LETS DATA FLOW FREELY FROM XT'S TO AT'S
MCT-FDC-1.2

HARD DISK CONTROLLER \$79.95
SUPPORTS 16 DRIVE SIZES, INCLUDING 10, 20, 30, 40 MB ■ DIVIDES 1 LARGE DRIVE INTO TWO LOGICAL DRIVES
MCT-HDC

RLI CONTROLLER \$119.95
TRANSFERS DATA 50% FASTER! ■ SUPPORTS UP TO 2 RLL HARD DRIVES ■ FOR XT COMPATIBLES
MCT-RLI

286/386 FLOPPY/HARD \$149.95
TRUE AT DESIGN ■ SUPPORTS UP TO TWO 360K/720K/1.2MB/1.44MB FDD'S ■ SUPPORTS 2 HDD'S (STD. TABLES)
MCT-AFH

286/386 RLL CONTROLLER \$199.95
SUPPORTS UP TO 2 RLL HARD DRIVES AND 2 FLOPPIES ■ SUPPORTS 360/720/1.2/1.44 MB FLOPPIES (5-1/2" & 3-1/2")
MCT-AFH-RLL

MULTIFUNCTION CARDS

MULTI I/O FLOPPY CONTROLLER \$79.95
SUPPORTS UP TO 2 360K FLOPPIES, 720K W/ DOS 3.2
SERIAL, PARALLEL, GAME PORT, CLOCK/CALENDAR
MCT-MIO

MULTI I/O CARD \$59.95
SERIAL PORT, CLOCK/CALENDAR W/BATTERY
PARALLEL PORT IS ADDRESSABLE AS LPT1 OR LPT2
MCT-IO

286/386 MULTIFUNCTION \$139.95
ADDS 1.5MB (3 MB WITH OPTIONAL PIGGYBACK CARD, OK INSTALLED) TO YOUR AT ■ INCLUDES SERIAL AND PARALLEL PORTS
MCT-AMF

MCT-AMF-MC 1.5MB PIGGYBACK BOARD \$29.95
AIO-SERIAL 2ND SERIAL PORT \$24.95

286/386 MULTI I/O CARD \$59.95
SERIAL, PARALLEL AND GAME PORTS ■ USES 16450 SERIAL SUPPORT CHIPS FOR HIGH SPEED OPERATION
MCT-AIO



MEMORY CARDS

576K RAM CARD \$59.95
SHORT SLOT ■ USER SELECTABLE CONFIGURATION TO 576K ■ 64K AND 256K RAM CHIPS (OK INSTALLED)
MCT-RAM

EXPANDED MEMORY CARD \$129.95
2MB LM MEMORY (OK INSTALLED) ■ USER EXPANDABLE TO 2 MB ■ CONFORMS TO LOTUS INTEL EMS
MCT-EMS (SHOWN)

MCT-AEMS 286/386 EMS CARD \$139.95



JDR MICRODEVICES, 2233 BRANHAM LANE, SAN JOSE, CA 95124
LOCAL (408) 866-6200 FAX (408) 559-0250 TELEX 171-110

RETAIL STORE: 1256 S. BASCOM AVE., SAN JOSE, CA
(408) 947-8881 HOURS: M-F, 9-7 SAT. 9-5 SUN. 12-4

NEW ADDRESS!

Terms: Minimum order \$10.00. For shipping & handling include \$3.50 for ground and \$4.50 for air. Orders over 1 lb and foreign orders may require additional shipping charges—contact the sales department for the amount. CA residents must include applicable sales tax. Prices subject to change without notice. We are not responsible for typographical errors. We reserve the right to limit quantities and to substitute manufacturer. All merchandise subject to prior sales. A full copy of our terms is available upon request. Items pictured may only be representative.



ORDER TOLL FREE 800-538-5000

COPYRIGHT 1989 JDR MICRODEVICES

CONTINENTAL US

Data Acquisition Processor™

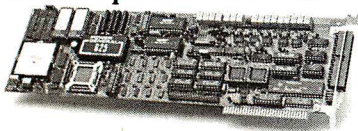

Onboard Intelligence For IBM PC/XT/AT/386

- 16 MHz 80C186 for general processing
- 20 MHz DSP56001 for digital signal processing
- Sustained digital signal processing of 10 MIPS
- FFT and FIR filtering without programming
- Acquires analog and digital inputs to 235K s/s
- Buffers and processes input data as required
- Updates analog or digital outputs to 250K s/s
- Over 100 commands without programming
- Custom commands may be written in C
- DAP 2400™ from \$2395

MICROSTAR
LABORATORIES

(206) 881-4286
2863 152 Ave. N.E.
Redmond, WA 98052
FAX (206) 881-5494

Circle 183 on Reader Service Card

April Showers Sale

3M 5.25" Mark Q Diskettes

The ultimate in diskette reliability, durability and quality.



DSDD 48TPI

DSHD IBM PC/AT

Sale
64¢
\$1.15

3M 3.5" Micro Diskettes

DS 135TPI

HD 2.0 MB



Sale
\$1.36
\$1.39

Minimum: 50 disks, 10 disks/box.

Toll Free: 1-800-258-0028

FREE CATALOG

Complete Line of Quality Supplies For Your Computer.
Foreign Inquiries Invited.

Minimum Order \$25.00. S&H: (Continental USA)
\$4.00/100 Disks. Educational Purchase Orders
Accepted. Prices Subject to Change.



Precision Data Products™

P.O. Box 8367, Grand Rapids, MI 49518
MI: 800-632-2468 • 313-645-4980
616-452-3457 • FAX: 616-452-4914

Circle 221 on Reader Service Card

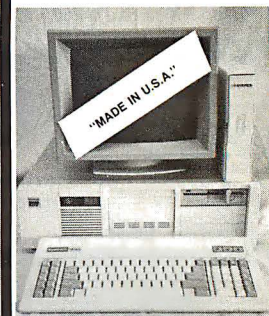

- System 1800 Basic System 8899 (MADE IN U.S.A. with quality)**
- Intel 80286 CPU
 - Fully compatible with IBM AT
 - 50 Mhz selectable, 8 slots
 - 512K on 1M mother board
 - 195 watt power supply 10/220
 - Clock/Calendar, Everex HD/DF cont.
 - FCC class "B" approved
 - 48 Hour factory high temp. dynamic burn-in
 - 1.2 MEG Teac Dr. AT Keyboard
 - Runs Autocad, Lotus, Xenix, Novell, all prop. Software
 - 200 pages old/documentation (written in U.S.A.)
 - 80287CO. Processor socket
 - 80000 units installed with customer region on line
 - Made in U.S.A. with 1 year warranty

Mono Sys (Basic Sys + Evergraphics 132 col. w/tp. 14" Everex Flat Mon.) Special \$995
EGA Sys (Basic Sys + Everex EGA card + 14" Everex EGA (317mm) Mon.) \$1414
Super EGA Sys (Basic Sys + Everex EGA card + 14EG Hi/Temp 9060 (317mm) Mon.) \$1700
System 1800 (8MHz, 288K 0 w/ai 512K, 25. IP, KB, Base system) \$1999
System 1200 (12MHz, 288K 0 w/ai 1 meg RAM, KB, Base system) \$1295
System 3000 (16MHz, 386K 0 w/ai, 1 meg, KB, Base system) \$1995
System 3000D (20MHz, 386K 0 w/ai, 1 meg, KB, Base system) \$2200

Full Line of Everex Products Available			
NEW	= 640K	386-290, 1m	\$2295
LCD	= 1.2m Dr	386-150, 1m	\$2195
PORTABLE	= 640x200	286-150/1, 512K	\$1629
	= Super Text LCD	286-120	\$1395
	= Back Lite		

Schwab Computer Center

"The Everex Store" - Authorized Everex Corp. VAR
3282 El Camino Real, Santa Clara, CA 95051
408-241-1210 Fax # 408-241-1279

Daily UPS

M-F 9-7, SAT 11-4
Prices change without notice

VISA/MC/AE

Circle 256 on Reader Service Card

DEC RAINBOW USERS

Run many IBM software packages at the speed of an IBM AT!

Our 12 MHz TURBOW 80286 accelerator board, with IDRIVE IBM-compatible floppy drive and CODE BLUE emulation software, can make your Rainbow fun again.

We specialize in hardware and software products to enhance and expand the useful life of your Rainbow. Call or write for information on our full line.

SUITABLE SOLUTIONS

1700 Wyatt Drive #12 • Santa Clara, CA 95054
Phone 408/727-9090 • FAX 408/727-0823

Circle 266 on Reader Service Card

Z80 HD64180 MICROPROCESSORS

C Compiler
Assembler/Linker
Remote Debug
Realtime Kernel
Emulator
PC Coprocessors
Proto Board

Integrated Software/Hardware Targeted for Z80/64180 Development on PC/XT/AT Platforms:

C-compiler (UNIX & ANSI std.)	\$495.00
Assembler/linker	\$195.00
In-circuit Emulator	\$995.00
Source/symbolic debugger	\$195.00
Multitasking kernel	\$395.00
Standalone Proto Board(64180µP)	\$295.00
PC Coprocessors--many versions, please inquire	

Z-World Engineering

1340 Covell Blvd. Suite 101
Davis, CA 95616
(916) 753-3722

Fax: (916) 753-5141



"Z80 Specialists"

In Germany: 08131/1687

Circle 309 on Reader Service Card

INTELLIGENT RS-232/422/485

- * COMMUNICATIONS
- * CONTROL
- * SYSTEMS DEVELOPMENT

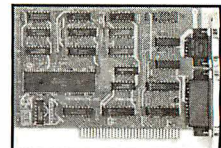

- * Hitachi HD64180 µP (6 or 9 mhz)
- * SBX connectors, 256K-516K RAM
- * 2 Serial Ports & 2 DMA channels

Z-World Engineering

1340 Covell Blvd., Ste. 101
Davis, CA 95616

(916) 753-3722

Germany: 08131/1687

Circle 310 on Reader Service Card

SUBSCRIPTION PROBLEMS?

If you have a problem with your BYTE subscription, write us with the details. We'll do our best to set it right. But we must have the name, address, and zip of the subscription (new and old address, if it's a change of address). If the problem involves a payment, be sure to include copies of the credit card statement, or front and back of cancelled checks. Include a "business hours" phone number if possible.

We want to help!

BYTE MAGAZINE

SUBSCRIBER SERVICE
P.O. Box 7643
TEANECK, NJ 07666-9866



EDITORIAL INDEX BY COMPANY

Index of companies covered in articles, columns, or news stories in this issue
Each reference is to the first page of the article or section in which the company name appears

INQUIRY #	COMPANY	PAGE	INQUIRY #	COMPANY	PAGE	INQUIRY #	COMPANY	PAGE
983	ADPAC.....	235, 246	863	COMPUTER DATA SYSTEMS.....	235, 246	866	INTERACTIVE DEVELOPMENT ENVIRONMENTS.....	235, 246
1047	ADVANCED GRAPHIC APPLICATIONS.....	97	1026	COMPUTER POWER.....	162	1021	IRWIN MAGNETIC SYSTEMS.....	129
1023	ADVANCED GRAVIS COMPUTER TECHNOLOGY.....	129	1002	COMPUTER SCIENCES.....	235, 246	1120	ISLAND SYSTEMS.....	78
986	ADVANCED LOGICAL SOFTWARE.....	235, 246	858	COMPUTER SYSTEMS ADVISERS.....	235, 246	1031	ITT POWERSYSTEMS.....	162
868	ADVANCED TECHNOLOGY INTERNATIONAL.....	235, 246	982	CONETIC SYSTEMS.....	135	1166	JAMECO ELECTRONICS.....	65
1016	AGS MANAGEMENT SYSTEMS.....	235, 246	1040	COPIA INTERNATIONAL.....	111	1133	JURISOFT.....	78
	AISI RESEARCH.....	11	998	CORTEX.....	235, 246			
1103	ALSOFT.....	141	888	CRICKET SOFTWARE.....	203	1032	KALGLO ELECTRONICS.....	162
1011	AMERICAN MANAGEMENT SYSTEMS.....	235, 246	1007	CULLINET SOFTWARE.....	235, 246	1009	KNOWLEDGEWARE.....	235, 246
1024	AMERICAN POWER CONVERSION.....	162	999	D. APPLETON.....	235, 246	1010	LANGUAGE TECHNOLOGY.....	235, 246
1006	ANDERSEN CONSULTING ..	235, 246	1072	DA SYSTEMS.....	151	989	LBMS.....	235, 246
	APPLE COMPUTER.....	11, 251	1045	DATA TRANSLATION.....	97	886	LETRASET USA.....	129, 203
859	APPLIED BUSINESS TECHNOLOGY.....	235, 246	878	DELOITTE, HASKINS & SELLS.....	235, 246	1022		
	APPLIED MICROSYSTEMS.....	11	1000	DIGITAL EQUIPMENT ..	11, 235, 246	1038	LOGITECH INTERNATIONAL SA.....	111
1158	ARTICULATE SYSTEMS.....	65		DIGITAL RESEARCH.....	303		LOGIX.....	235
1136	ASHTON-TATE.....	78	1101	DIGITALK.....	141		LOTUS DEVELOPMENT.....	303
873	ASYST TECHNOLOGIES.....	235, 246	1165	DRAGON SYSTEMS.....	65	1157	LUNDY ELECTRONICS & SYSTEMS.....	11, 65
	AT&T.....	11	1027	DRS POWER PRODUCTS.....	162			
	ATARI.....	251	1126	DURHAM TECHNICAL IMAGES ..	78			
865	ATHERTON TECHNOLOGY.....	235, 246		ELECTRONIC INDUSTRIES ASSOCIATION.....	11		MAGNETIC POWER.....	11
	ATI.....	157		ELECTRONIC MAIL ASSOCIATION.....	151	1013	MANAGER SOFTWARE PRODUCTS.....	235, 246
990	BACHMAN INFORMATION SYSTEMS.....	235, 246	1028	EMERSON COMPUTER POWER ..	162	1128	MATHSOFT.....	78
	BERKELEY SPEECH TECHNOLOGY.....	11		EVEREX.....	157	860	MCDONNELL-DOUGLAS ..	235, 246
1043	BORLAND INTERNATIONAL.....	97, 111		EX MACHINA.....	11	1075	MCI MAIL.....	151
1044	151	1029	EXIDE ELECTRONICS.....	162	985	MENTOR GRAPHICS.....	235, 246
1071	BYTE.....	151		FARALLON COMPUTING.....	11	1014	META SYSTEMS.....	235, 246
				FRANCIS BITTER NATIONAL MAGNET LABORATORY.....	11	1124	METROPOLIS COMPUTER NETWORKS.....	78
871	CADRE TECHNOLOGIES....	235, 246		FRANKLIN COMPUTER.....	11	996	MICRO FOCUS.....	235, 246
869	CADWARE.....	78, 235, 246		FUJITSU.....	292	1153	MICRO I.....	65
1144				FULL COLOR COMPUTING.....	11	887	MICROSOFT.....	111, 157, 203, 303
	CARNEGIE-MELLON UNIVERSITY.....	11, 209		GENERAL ELECTRIC.....	11	1041	MICROTEC RESEARCH.....	11
1141	CASEWORKS.....	78		GENERAL POWER SYSTEMS.....	162	1169	MIRA IMAGING.....	65
	CENTER FOR ADVANCED INFORMATION MANAGEMENT.....	209	1030	GENOA.....	157		MIT.....	11
1019	CGI SYSTEMS.....	235, 246		HARVARD UNIVERSITY PRESS... 51			MITSUBISHI.....	292
995	CHEN & ASSOCIATES.....	235, 246		HEWLETT-PACKARD.....	11, 292		MOTOROLA.....	11
	CHIPS & TECHNOLOGIES.....	11		HIGHLIGHTED DATA.....	11		MT XINU.....	11
997	CODING FACTORY.....	235, 246		HITACHI.....	11, 292	1001	NASTEC.....	235, 246
1155	COLORADO MEMORY SYSTEMS.....	65	852	HOWTEK.....	189		NEC.....	11
	COMMODORE COMPUTERS.....	251				1017	NETRON.....	235, 246
1164	COMPAQ COMPUTER.....	11, 65	867	I-LOGIX.....	246	1159	NETRONIX.....	65
1042	COMPLETE LOGIC SYSTEMS.....	111	1156	IBM.....	11, 65, 251, 292, 303	1151	NETWORK COMPUTING DEVICES.....	65
1074	COMPUSERVE.....	151	890	IMAGINE THAT!.....	197		NEXT.....	11
1025	COMPUTER ACCESSORIES.....	162	1005	INDEX TECHNOLOGY.....	235, 246		NOVELL.....	303
991	COMPUTER ASSOCIATES INTERNATIONAL.....	235, 246	1137	INFINITE GRAPHICS.....	78	1123	OFFETE ENTERPRISES.....	78
				INFODYNE.....	235	994	ON-LINE SOFTWARE INTERNATIONAL.....	235, 246
			1132	INFORMATION RESEARCH.....	78	1003	OPTIMA.....	235, 246
			988	INSIGNIA SOLUTIONS.....	11	993	ORACLE.....	11, 235, 246
				INTEGRATED SYSTEMS	235, 246			
				INTEL.....	11			

INQUIRY #	COMPANY	PAGE	INQUIRY #	COMPANY	PAGE	INQUIRY #	COMPANY	PAGE
872	PANSOPHIC SYSTEMS	235, 246		SAMSUNG	157	1167	ULTRA-LUM	65
	PARADISE	157		SEAGATE	157	1034	UNISON TECHNOLOGIES	162
1130	PARAGON CONCEPTS	78	851	SHARP ELECTRONICS	97, 189	1150	UNISYS	65
1102	PARCPLACE SYSTEMS	141	1046				UNIVERSITY OF ILLINOIS NATIONAL CENTER FOR SUPERCOMPUTING APPLICATIONS	279
1020	PEAT MARWICK ADVANCED TECHNOLOGY	235, 246		SILICON GRAPHICS	11			
	PERSONAL DATA SYSTEMS	11	1012	SIMON AND SCHUSTER	51			
1039	PETER NORTON COMPUTING	111	1122	SOFTLAB	235, 246			
1018	PHOENIX TECHNOLOGIES		1125	SOFTSCIENCE	78			
		235, 246, 303	1125	SOFSHELL INTERNATIONAL	78	875	VIASOFT	235, 246
	PIXAR	267	1003	SOLA ELECTRIC	162		VIDEO SEVEN	157
862	POLYTRON	235, 246	1004	SPS SOFTWARE PRODUCTS & SERVICES	235, 246	876	VISIBLE SYSTEMS	235, 246
870	POPKIN SOFTWARE & SYSTEMS	235, 246		SUN MICROSYSTEMS	292	877	VISUAL SOFTWARE	235, 246
861	PROMOD	235, 246	1162	SUPERMAC TECHNOLOGY	11, 65	1035	VITEQ	162
	QUADRAM	157	1160	SYNCH RESEARCH	65			
			1015	SYSCORP INTERNATIONAL	78, 235, 246	854	WELLS AMERICAN	179
1163	RASTEROPS	65	1143	SYSTEMS INTEGRATION ASSOCIATES	106	1168	WESTCOAST TECHNICAL & HOBBY	65
992	READY SYSTEMS	235, 246					WESTERN DIGITAL	157
	RELATIONAL TECHNOLOGY	11	1121	TECHALLIANCE	78	1073	WESTERN UNION	151
	ROME AIR DEVELOPMENT CENTER	11	864	TELELOGIC EUROPE	235, 246	981	WORDPERFECT	135
	RR SOFTWARE	111	1008	TEXAS INSTRUMENTS	11, 235, 246	1037	WORKMAN & ASSOCIATES	111
987	SAGE SOFTWARE	235, 246	1131	TLB	78			
1048	SAK TECHNOLOGIES	97	874	TRANSFORM LOGIC	235, 246	984	YOURDON	235, 246
							ZAX	11

COMING UP IN BYTE

PRODUCTS IN PERSPECTIVE:

In the front of the May BYTE will be Microbytes, What's New, and Short Takes. May's Short Takes will include MultiBoot, an OS/2 booting utility from Bolt Systems; Compaq's external hard disk drive subsystem; Connectix's Virtual, a program that provides 8 megabytes of virtual RAM for the Macintosh II; Lotus's Magellan; and Disk Technician Advanced, an upgraded hard disk drive test and analysis program from Prime Solutions.

May's **Product Focus** will be on three-dimensional CAD software. These ever-more-capable programs on microcomputers are getting more popular all the time. Find out the state of the art in this article.

System reviews will consider two hand-held computers, Sharp's Wizard and Psion's Organiser II. Also on the list is a comparison of the Tandon and FiveStar systems featuring removable disk cartridges.

A couple of **hardware reviews** are a comparison of add-in facsimile cards for the Mac and a comparison of TrueScan and OmniPage scanners.

Software reviews concentrate on JPI's TopSpeed Modula-2 and Logic Gem from Sterling Castle; **application reviews** deal with Samna's Ami, a plethora of statistical analysis packages for the Mac, and Crowninshield Software's MediaBase.

IN DEPTH:

Unix, once obscure and often difficult, is enjoying something of a flowering of popular appreciation. With increased attention to easily absorbed user interfaces, more people are coming to know its speed and power. Our May In Depth section looks at Unix shells, Unix communications, Unix security, new incarnations of Unix, and making the changeover from DOS.

FEATURES:

Our May lineup of **columnists** begins with the Expert Advice group in the front of the book: Jerry Pournelle's Computing at Chaos Manor, Ezra Shapiro's Applications Plus, Wayne Rash's Down to Business, Brock N. Meek's COM 1, Don Crabb's Macinations, and Mark Minasi's OS/2 Notebook. Back in the Features section, under the heading Hands On, our two columns are Brett Glass's Under the Hood and Rick Grehan's Some Assembly Required.

In addition, we'll have a feature that analyzes the latest advancement in microcomputing science, **quantum technology**. While standard microcomputing manufacturing techniques are starting to reach physical size and speed limits imposed by the physics of electron flow, quantum technology offers improvements that are measured in orders of magnitude. If we've been waiting for the emergence of the next "breakthrough" technology, this may well be it.

READER SERVICE

To get further information on the products advertised in BYTE, fill out the reader service card by circling the numbers on the card that correspond to the inquiry number listed with the advertiser. This index is provided as an additional service by the publisher, who assumes no liability for errors or omissions.

* Correspond directly with company.

Alphabetical Index to Advertisers

Inquiry No.	Page No.	Inquiry No.	Page No.	Inquiry No.	Page No.	Inquiry No.	Page No.	
8	2001 SALES	258	87	ELLIS COMPUTING	114	180	MICROPROCESSORS UNLTD.	344
9	2001 SALES	258	88	EMERSON COMPUTER POWER	181	181	MICRORIM	118,119
10	ABRAXAS SOFTWARE	242	89	EMERSON COMPUTER POWER	181	182	MICRORIM	118,119
316	ACCESS GRAPHICS TECH.	225	90	EMPIRICAL RESEARCH SYS.	298	*	MICROSOFT	13
11	ACM SIGGRAPH '89	281	91	ENGINEERS COLLABORATIVE	337	*	MICROSOFT	92,93
*	ADOBE	75	92	EPSON ACCESSORIES	334	183	MICROSTAR LABORATORIES	354
13	ADVANCED COMPUTER PROD.	345	93	EVEREX COMPUTER SYS.	28,29	184	MICROTECH CONVER.SYS.	337
14	ADVANCED LOGIC RES.	76,77	94	EVEREX COMPUTER SYS.	28,29	186	MICROWAY	55
15	ADVANCED LOGIC RES.	76,77	95	EXECUTIVE PHOTO & SUPPLY	177	*	MICROWAY	241
16	ADVANTAGE SOFTWARE	215	96	FLAGSTAFF ENGINEERING	110	187	MIRO DATENSYTTME	273
17	AK SYSTEMS	340	97	FLAGSTAFF ENGINEERING	110	188	MITSUBISHI	115
18	ALADDIN KNOWLEDGE SYS.	144	98	FLAGSTAFF ENGINEERING	110	189	MITSUBISHI	115
19	ALPHA PRODUCTS CO.	348,349	99	FLAGSTAFF ENGINEERING	110	190	MITSUBISHI	254,255
20	ALTEX ELECTRONICS	171	100	FORESIGHT RESOURCES	39	191	MITSUBISHI	254,255
21	AMERICAN POWER CONVRSN.	138	101	FORESIGHT RESOURCES	39	192	MIX SOFTWARE	317
22	AMERICAN SM. BUS. COMP.	287	*	FORTE-COMMUNICATIONS INC.	58	*	MONTGOMERY GRANT.	219
*	AMPRO	200	102	FORTRON CORP.	30	193	NANAO	266
23	AMS	344	103	FORTRON CORP.	30	194	NANAO	266
24	ANALOGY CORP.	332,333	104	FOX SOFTWARE	25	195	NANTUCKET	26
25	ANNABOOKS	330	105	FTG DATA SYSTEMS	334	317	NATIONAL INSTRUMENTS	145
*	ANTHRO	42	319	FUTURE COMPUTER SYS.	101	318	NATIONAL INSTRUMENTS	145
26	AST RESEARCH	185-187	320	FUTURE COMPUTER SYS.	101	*	NEC HOME ELECT. (USA)	48,49
27	AST RESEARCH	185-187	107	GAAN COMPUTER SUPPLIES	344	*	NEC INFORMATION SYSTEMS C/II	
30	ATI TECHNOLOGIES	35	108	GATEWAY 2000	8,9	324	NISCA, INC.	234
31	ATRON	64	109	GENERAL ELECTRIC (GEISCO)	50	198	NOHAU CORP.	334
*	AVIS	263	110	GENERIC SOFTWARE	261	199	NUMONICS	265
34	A.N. WHOLESALE & RETAIL	335	111	GENERIC SOFTWARE	261	200	ON LINE STORE	243
35	BASF	43	112	GENOA SYSTEMS CORP.	253	201	ON TARGET	340
36	BAYTECH	156	113	GENUS	286	*	ORACLE	73
37	BEST COMPUTER	140	114	GEYSER INFORMATICS	193	202	OVERLAND DATA	336
38	BEST COMPUTER	140	115	GOLDEN BOW	205	203	PACIFIC COMPUTER	331
39	BINARY ENGINEERING	275	116	GOLDEN BOW	205	204	PACIFIC COMPUTER	331
*	BINARY TECHNOLOGY	340	117	GOODWAY	60	205	PACIFIC DATA PRODUCTS	127
40	BIOLOGICAL ENGINEERING	176	118	GTEK	310	206	PACIFIC DATA PRODUCTS	127
*	BIX	272	119	GTEK	310	209	PARA SYSTEMS	167
450	BIX	290,291	120	HAMMERLY COMP. SERV.	87	210	PARC PLACE SYSTEMS.	53
41	BLAISE	45	121	HARRIS/3M	154,155	211	PATTON & PATTON	122
42	BORLAND	69	122	HEWLETT PACKARD PERIPH.	36,37	212	PAUL MACE SOFTWARE	256
43	BORLAND	69	123	HEWLETT PACKARD PERIPH.	133	213	PD SOFTWARE HOUSE	40
44	BP MICROSYSTEMS	338	124	HEWLETT PACKARD PERIPH.	134	214	PERISCOPE	123
45	BUFFALO PRODUCTS	259	125	HI TECH EQUIPMENT CORP.	338	215	PERISCOPE	123
46	BUFFALO PRODUCTS	259	126	HIGH RES TECHNOLOGY	338	216	PERSONAL SPACE COMM.	336
47	BUMBLEBEE SOFTWARE	52	127	HOOLEON	96	217	PERSONAL TEX	274
*	BUYER'S MART	319-329	128	HOOLEON	96	322	PETER NORTON	16B,16C
*	BYTE BACK ISSUES	94	129	HORSTMANN SOFTWARE	34	323	PETER NORTON	16B,16C
48	BYTE BITS	338	130	HWA HSIN ELECTRONIC CO.	84	218	PHAR LAP	46
*	BYTE BOOK CLUB	160,161	131	IC EXPRESS	342	219	POCKETSOFT	95
*	BYTE SUB. MESSAGE	184,315	133	IEEE	116	220	POLYTRON	208
*	BYTE SUB SERVICE	282	134	IMPACT COMPUTER SYSTEMS	286	221	PRECISION DATA PRODUCTS	354
*	BYTE TIPS	330	*	INTECTRA INC.	337	222	PRECISION PLUS SOFTWARE	60
49	BYTE COMP. CORP.	342	135	INTEGRAND	174	325	PRIME SOLUTIONS	213
*	BYTEWEEK/NEWSLETTER	234	136	INTELLITECH	175	326	PRIME SOLUTIONS	213
50	B&B ELECTRONICS	334	137	INTERACTIVE SYSTEMS	7	223	PROGRAMMER'S PARADISE	62,63
51	B&C MICROSYSTEMS	337	138	IO TECH	142	224	PROGRAMMER'S SHOP	114
51	B&C MICROSYSTEMS	337	139	IO TECH	142	225	PROTECH MARKETING	102
327	CADRE TECHNOLOGIES, INC.	214	140	JAMECO	346,347	226	PROTECH MARKETING	102
52	CAD WAREHOUSE	283	141	JB COMPU-TRONIX	344	227	PROTEUS TECH. CORP.	27
53	CALCOMP	250	142	JEIKO	344	228	PROXIMITY	244
54	CALCOMP	250	143	JENSEN & PARTNERS	125	229	PROXIMITY	244
*	CALIFORNIA DIGITAL	343	6	J.D.R. MICRODEVICES	350-353	230	QUADRAM	248
55	CAPITAL EQUIPMENT	120	7	J.D.R. MICRODEVICES	350-353	231	QUADRAM	248
56	CAPITAL EQUIPMENT	121	132	J-TECH CORP.	344	232	QUALSTAR CORP.	335
57	CIS (LEE YUAN CO.)	54	144	KADAK	335	233	QUANTUM	91
*	CLEO SOFTWARE	128	145	KEA SYSTEMS	344	234	QUARTERDECK	22
59	COEFFICIENT SYSTEMS	218	146	KNOWLEDGE GARDEN	201	235	QUARTERDECK	22
*	COMPACT DISK CLUB	245	147	KORE, INC.	334	236	QUARTERDECK	23
332	COMPACT DISK PRODUCTS	298	148	KYE INTERNATIONAL CO.	188	237	QUARTERDECK	23
60	COMPUCLASSICS	117	149	KYE INTERNATIONAL CO.	188	238	QUATECH	342
61	COMPUCOM	330	150	LA COMPUTER	339	239	QUATECH	342
62	COMPUSAVE	331	151	LA COMPUTER	339	240	QUATECH	342
63	COMPUTER FRIENDS	44	152	LAHEY COMPUTER SYSTEMS	218	241	QUATECH	342
328	COMPUTER FRIENDS	295	154	LAN-MARK SYSTEMS	334	242	RADIO SHACK	CIV
64	COMPUTER MAIL ORDER	82,83	155	LINK COMPUTER GRAPHICS	340	243	RADIO SHACK	139
65	COMPUTERLANE	302	156	LOGICAL DEVICES	336	*	RAIMA	47
66	COMPUTRADE	100	157	LOGICAL DEVICES	336	313	RAINBOW TECH.	105
67	CONTECH COMP. CORP.	338	158	LOGICAL DEVICES	336	314	RAINBOW TECH.	105
68	CONTROL SYSTEMS	248B	159	LOGICAL DEVICES	336	245	RCS	54
69	CONTROL SYSTEMS	248B	311	LOGITECH	70,71	246	REAL TIME DEVICES	337
70	CONTROL VISION	336	312	LOGITECH	70,71	247	RENEGADE TECHNOLOGY	14,15
71	CORECO	264	*	MACMILLAN BOOK CLUB	17	248	ROSE ELECTRONICS	150
72	COVOX	334	333	MANUFACT. HANOVER TRUST	229	249	SABINA INT'L	335
*	CW DATA LABS	344	162	MANX SOFTWARE SYSTEMS	85	252	SAFWARE INC.	340
73	C-SOURCE	289	163	MAP INFO	19	253	SAIC	102
*	DAMARK INTERNATIONAL INC.	130	164	MARYMAC INDUSTRIES	337	254	SAIC	102
74	DATA TRANSLATION	33	165	MATHSOFT	67	255	SANTA CRUZ OPERATION	79
*	DAYTRON ELECTRONICS	335	166	MATRIX	59	256	SCHWAB COMP.	354
77	DELL COMPUTER	C11	167	MAXON	269	257	SCIENCE ACCESSORIES	277
*	DELL COMPUTER	44A,B	168	MAXON	269	*	SEAGATE	137
78	DIGITALK	41	*	MCGRAW-HILL NRI	272A,B	258	SHAMROCK	217
79	DISKOTECH	338	170	MEAD COMPUTER	341	259	SHECOM COMPUTERS	202
80	DISKETTE CONNECTION	335	171	MEDIA CYBERNETICS INC.	196	260	SHECOM COMPUTERS	202
81	DIVERSIFIED COMPUTER	340	172	MEDIA CYBERNETICS INC.	196	261	SILICON	18
331	DIVERSIFIED TECHNOLOGY	342	173	MEGASOFT	335	262	SN'W ELECTRONICS	38
82	DTK	178	174	MEGATEL	318	*	SOFTWARE DEV. SYS.	99
83	DTK	178	175	MERRITT COMPUTER PROD.	318	263	SOTA	21
84	DYNAMIC ELECTRONICS	338	177	MICRO TELEIS	216	264	SPECTRUM	81
85	ECOSOFT	146	178	MICROVITEC	24	265	STATSOFT	113
86	ELEXOR	340	179	MICROVITEC	24	266	SUITABLE SOLUTIONS	354
267	SUNFLEX	143	180	MICROPROCESSORS UNLTD.	344	267	SUNFLEX	143
268	SUNFLEX	143	181	MICRORIM	118,119	268	SUNFLEX	143
269	SUPERSOFT	296	182	MICRORIM	118,119	269	SUPERSOFT	296
270	SURAH INC.	337	*	MICROSOFT	13	270	SURAH INC.	337
271	SYSGEN	16A	*	MICROSOFT	92,93	271	SYSGEN	16A
272	SYSTAT	271	183	MICROSTAR LABORATORIES	354	272	SYSTAT	271
273	SYSTAT	271	184	MICROTECH CONVER.SYS.	337	273	SYSTAT	271
274	S-100	194	186	MICROWAY	55	274	S-100	194
275	TALKING TECHNOLOGY	340	*	MICROWAY	241	275	TALKING TECHNOLOGY	340
276	TATUNG	273	187	MIRO DATENSYTTME	273	276	TATUNG	273
277	TELCOR	212	188	MITSUBISHI	115	277	TELCOR	212
278	TELEBIT	103	189	MITSUBISHI	115	278	TELEBIT	103
279	TELEBYTE TECHNOLOGY	52	190	MITSUBISHI	254,255	279	TELEBYTE TECHNOLOGY	52
280	TELEMART	223	191	MITSUBISHI	254,255	280	TELEMART	223
281	TELEMART	223	192	MIX SOFTWARE	317	281	TELEMART	223
282	TOSHIBA COMPUTERS	88,89	*	MONTGOMERY GRANT.	219	282	TOSHIBA COMPUTERS	88,89
283	TOSHIBA COMPUTERS	88,89	193	NANAO	266	283	TOSHIBA COMPUTERS	88,89
284	TOUCHBASE SYSTEMS, INC.	16D	194	NANAO	266	284	TOUCHBASE SYSTEMS, INC.	16D
329	TRUE DATA PRODUCTS	112	195	NANTUCKET	26	329	TRUE DATA PRODUCTS	112
285	TRUVISION	173	317	NATIONAL INSTRUMENTS	145	285	TRUVISION	173
286	TRW INT'L	340	318	NATIONAL INSTRUMENTS	145	286	TRW INT'L	340
287	T.S.I.	195	*	NEC HOME ELECT. (USA)	48,49	287	T.S.I.	195
288	T.S.I.	195	*	NEC INFORMATION SYSTEMS C/II		288	T.S.I.	195
289	US ROBOTICS	61	324	NISCA, INC.	234	289	US ROBOTICS	61
330	V 3 CORP.	257	198	NOHAU CORP.	334	330	V 3 CORP.	257
331	VENTURA PERIPHERALS	285	199	NUMONICS	265	331	VENTURA PERIPHERALS	285
291	VERBANT CORPORATION	153	200	ON LINE STORE	243	291	VERBANT CORPORATION	153
*	VERMONT CREATIVE	10	201	ON TARGET	340	*	VERMONT CREATIVE	10
292	VERSASOFT CORPORATION	86	*	ORACLE	73	292	VERSASOFT CORPORATION	86
293	VNS AMERICA	148,149	202	OVERLAND DATA	336	293	VNS AMERICA	148,149
294	VNS AMERICA	247	203	PACIFIC COMPUTER	331	294	VNS AMERICA	247
315	WAREHOUSE DATA	220	204	PACIFIC COMPUTER	331	315	WAREHOUSE DATA	220
295	WELLS AMERICAN (DOMESTIC) 31		205	PACIFIC DATA PRODUCTS	127	295	WELLS AMERICAN (DOMESTIC) 31	
296	WELLS AMERICAN (INT'L)	31	206	PACIFIC DATA PRODUCTS	127	296	WELLS AMERICAN (INT'L)	31
297	WELTEK DIGITAL INC.	244	209	PARA SYSTEMS	167	297	WELTEK DIGITAL INC.	244
298	WELTEK DIGITAL INC.	244	210	PARC PLACE SYSTEMS.	53	298	WELTEK DIGITAL INC.	244
299	WIESEMANN & THEIS	126						

READER SERVICE

Advertising Supplements included with this issue:
Jade Computer (U.S. and Canada Subscribers)

BYTEWEEK (Mid-Atlantic, South, Pacific Coast,
and Canada Subscribers)

Inquiry No.	Page No.	Inquiry No.	Page No.	Inquiry No.	Page No.	Inquiry No.	Page No.	
<i>Continued</i>								
452	PACIFIC DATA PROD. 96IS-13	* BYTE WAREHOUSE/SALE MW-15	* COMPUTERS FOR THE BLIND M/AT-2	477	DIGIFONTS PC-7	* DIGITAL EQUIPMENT CORP. PC-5		
434	PC CALC 96IS-24	541 * COMPARE COMPUTERS MW-7	509	GOLDEN BOW SYSTEMS M/AT-1	478	GOLDEN BOW SYSTEMS PC-1		
435	RCS TECHNOLOGY CORP. 96IS-51	* COMPUTERS FOR THE BLIND MW-4	510	GOLDEN BOW SYSTEMS M/AT-1	479	GOLDEN BOW SYSTEMS PC-1		
436	RINGDALE PERIPHERALS 96IS-31	542 CONTINENTAL TRADING MW-18, 19					480	ISLAND SYSTEMS PC-12
437	SIEMENS 96IS-21	543 CONTINENTAL TRADING MW-18, 19					481	JB TECHNOLOGIES PC-9
438	SILICON INTEGRATED SYS. 96IS-52	546 HARD DRIVES INT'L MW-20					482	MEXTEL PC-2
	* SOFTLINE CORPORATION 96IS-35	547 HARD DRIVES INT'L MW-20					483	MICRO UNIVERSE PC-12
440	SUN MICROSYSTEMS 96IS-19	548 ISD MW-9					484	MID-CITIES COMP/SOFT PC-3
448	TAIWAN VIDEO & MONITOR 96IS-49	549 ISD MW-9					485	P.11 ELECTRONICS PC-6
441	TOPLINK 96IS-48	550 ISLAND SYSTEMS MW-2					486	P.11 ELECTRONICS PC-6
442	TRIANGLE DIGITAL 96IS-28	551 LASER MASTER MW-3					487	REASONABLE SOLUTIONS PC-11
443	UNITECH 96IS-20	552 LASER MASTER MW-3					488	SEVERE DISCOUNT COMP. PC-4
444	UNITRON INC. 96IS-53	* MCGRAW-HILL BOOKS MW-22						
445	USA SOFTWARE 96IS-11	553 MEXTEL MW-21						
		* MICROCOMP. MKTG.CNCL. MW-13						
INT'L DIRECT RESPONSE POSTCARDS								
* ATTACHMATE 96IS		554 N VIEW MW-1						
* B&S MULTISOT GMBH 96IS		555 NET LOGIC MW-17						
* CINEMAGIC PRODUCTIONS 96IS		556 NEWER TECHNOLOGY MW-8						
* LINGUISTIC PRODUCTS 96IS		557 O.S. ASSOCIATES MW-21						
* METRABYTE 96IS		558 O.S. ASSOCIATES MW-21						
* NATIONAL INSTRUMENTS 96IS		559 UNDERWARE ELECT. MW-24						
* NILS WENDEL CO. 96IS		560 U.S. MICRO ENGINEERING MW-23						
* SOFTWARE EXCITEMENT 96IS		561 U.S. MICRO ENGINEERING MW-23						
* TOUCHBASE SYSTEMS 96IS		562 USER FRIENDLY MW-23						
		564 VITEQ MW-11						
		565 VITEQ MW-11						
		566 Y.E.S. MULTINATIONAL, INC. MW-5						
REGIONAL SECTIONS								
Midwest 96 MW 1-24		Mid-Atlantic 96 M/AT 1-8		Northeast 96 NE 1-16		South 96 SO 1-12		
539	BUSINESS MICRO SYS. MW-17	* BYTE TIPS M/AT-4		515	APPLIED PROG. ELEC. NE-9	493	4 GUYS COMPUTERS SO-2	
540	BUSINESS MICRO SYS. MW-17	* BYTEWEEK/NEWSLETTER M/AT-5		516	BOSTON UNIVERSITY CORP. NE-3	495	BELTRON COMPUTER SO-3	
		508 COMMUNICATION RES.GRP. M/AT-3		* BYTEWEEK/NEWSLETTER NE-14		* BYTEWEEK/NEWSLETTER SO-8		
				517	COMMUNICATION RES.GRP. NE-12	496	COMP. MASTERS OF AUG. SO-6	
				* COMPUTERS FOR THE BLIND NE-10		* COMPUTERS FOR THE BLIND SO-9		
				518	DATAWARE PRODUCTS NE-6	506	COMTEQ COMP. CORP. SO-11	
				519	DATAWARE PRODUCTS NE-6	499	COWELL CORPORATION SO-4	
				520	ELECTRIFIED DISCOUNTERS NE-11	500	COWELL CORPORATION SO-4	
				521	GOLDEN BOW SYSTEMS NE-5	504	DRS POWER PRODUCTS SO-11	
				522	GOLDEN BOW SYSTEMS NE-5	505	DRS POWER PRODUCTS SO-11	
				523	HERTZ COMPUTERS NE-13	* EXPOCONSUL INT'L SO-7		
				524	LOGIX NE-8	501	HARD DRIVES INT'L SO-5	
				525	LOGIX NE-8	502	HARD DRIVES INT'L SO-5	
				526	LOGIX NE-8	* MICROCOMP. MKTG.CNCL. SO-10		
				* MANCHESTER EQUIP. NE-1		* PRINTERS PLUS, INC. SO-1		
				* MANCHESTER EQUIP. NE-CARD		* SM INDUSTRIES SO-9		
				527	PATRIOT COMPUTERS NE-4	503	UNDERWARE ELECTRONICSSO-12	
				528	PC LINK NE-7	* Correspond directly with company.		
				529	SOFTWARE BOTTLING CO. NE-15			
				530	TAN COMPUTER NE-10			
				531	UNDERWARE ELECTRONICSSNE-16			
				532	WESTWOOD COMPUTER NE-2			
Pacific Coast 96 PC 1-12								
476	4 GUYS COMPUTERS PC-6			* BYTEWEEK/NEWSLETTER PC-8				

BYTE ADVERTISING SALES STAFF:

Steven M. Vito, Associate Publisher/V.P. of Marketing, One Phoenix Mill Lane, Peterborough, NH 03458, tel. (603) 924-9281
Jennifer L. Bartel, West Coast Regional Sales Manager, 8111 LBJ Freeway, Suite 1350, Dallas, Tx 75251, tel. (214) 644-1111
L. Bradley Browne, Telemarketing Director, One Phoenix Mill Lane, Peterborough, NH 03458, tel. (603) 924-9281

NEW ENGLAND
ME, NH, VT, MA, RI, ONTARIO
CANADA & EASTERN CANADA
John C. Moon (617) 262-1160
McGraw-Hill Publications
575 Boylston Street
Boston, MA 02116

ATLANTIC
NY, NYC, CT, NJ (NORTH)
Leah G. Rabinowitz (212) 512-2096
Ken Tashly (212) 512-2645
McGraw-Hill Publications
1221 Avenue of the Americas—
36th Floor
New York, NY 10020

EAST
PA, NJ (SOUTH),
MD, W. VA, DE, D.C.
Thomas J. Brun (215) 496-3833
McGraw-Hill Publications
Three Parkway
Philadelphia, PA 19102

SOUTHEAST
NC, SC, GA, FL, AL, TN, VA
Thomas Tolbert (404) 252-0626
McGraw-Hill Publications
4170 Ashford-Dunwoody Road
Suite 420
Atlanta, GA 30319

MIDWEST
IL, MO, KS, IA, ND, SD, MN,
KY, OH, WI, NB, IN, MI, MS
Kurt Kelley (312) 751-3740
McGraw-Hill Publications
Blair Building
645 North Michigan Ave.
Chicago, IL 60611

**SOUTHWEST,
ROCKY MOUNTAIN**
CO, WY, OK, TX, AR, LA
Carl Heinrich (713) 462-0757
McGraw-Hill Publications
7600 W. Tidwell Rd.—Suite 500
Houston, TX 77040

SOUTH PACIFIC
SOUTHERN CA, AZ, NM,
LAS VEGAS
Ron Cordek (714) 557-6292
McGraw-Hill Publications
3001 Red Hill Ave.
Building #1—Suite 222
Costa Mesa, CA 92626

Tom Harvey (213) 480-5243
McGraw-Hill Publications
3333 Wilshire Boulevard #407
Los Angeles, CA 90010

NORTH PACIFIC
HI, WA, OR, ID, MT,
NORTHERN CA,
NV (except LAS VEGAS),
W. CANADA, UT
Christine Kopec (415) 362-4600
McGraw-Hill Publications
425 Battery Street
San Francisco, CA 94111

Bill McAfee (408) 879-0371
McGraw-Hill Publications
1999 South Bascom Ave.
Suite #210
Campbell, CA 95008

BYTE BITS (2x3)
Mark Stone (603) 924-6830
BYTE Publications
One Phoenix Mill Lane
Peterborough, NH 03458

The Buyer's Mart (1x2)
Brian Higgins (603) 924-3754
BYTE Publications
One Phoenix Mill Lane
Peterborough, NH 03458

Regional Advertising
Scott Gagnon (603) 924-4380
BYTE Publications
One Phoenix Mill Lane
Peterborough, NH 03458

Larry Levine (603) 924-4379
BYTE Publications
One Phoenix Mill Lane
Peterborough, NH 03458

Barry Echavarria (603) 924-2574
BYTE Publications
One Phoenix Mill Lane
Peterborough, NH 03458

National Sales
Liz Coyman (603) 924-2518
Dan Harper (603) 924-2598
Elisa Lister (603) 924-2665
BYTE Publications
One Phoenix Mill Lane
Peterborough, NH 03458

BYTE Deck Mailings
Ed Ware (603) 924-6166
BYTE Publications
One Phoenix Mill Lane
Peterborough, NH 03458

**A/E/C Computing Deck
Computing for Engineers**
Mary Ann Goulding
(603) 924-2664
BYTE Publications
One Phoenix Mill Lane
Peterborough, NH 03458

International Advertising Sales Staff:

Mr. Hans Csokor
Publimedia
Reisnerstrasse 61
A-1037 Vienna, Austria
222 75 76 84

Mrs. Gurit Gepner
McGraw-Hill Publishing Co.
PO Box 2156
Bat Yam, 59121 Israel
3 866 561 321 39

Ros Weyman
Serving Germany, Austria, & Switzerland
McGraw-Hill Publishing Co.
34 Dover St.
London W1X 4BR
England 01 493 1451

Karen Lennie
McGraw-Hill Publishing Co.
34 Dover St.
London W1X 4BR
England 01 493 1451

Michael Karnig
Andrew Karnig & Associates
Finnbodavagen
S-131 31 Nacka, Sweden
8-44 0005

Mr. Alain Faure
McGraw-Hill Publishing Co.
128 Faubourg Saint Honore
75008 Paris
France
(1) 42-89-03-81

Mrs. Maria Sarmiento
Pedro Teixeira 8, Off. 320
Iberia Mart I
Madrid 4, Spain
1 45 52 891

Emilio Zerboni
McGraw-Hill Publishing Co.
Via Flavio Baracchini 1
20123 Milan, Italy
(2) 89010103

Seavex Ltd.
400 Orchard Road #10-01
Singapore 0923
Republic of Singapore
Tel: 734-9790
Telex: RS35539 SEAVEX

Seavex Ltd.
503 Wilson House
19-27 Wyndham St.
Central, Hong Kong
Tel: 5-260149
Telex: 60904 SEVEX HX

Masaki Mori
McGraw-Hill Publishing Co.
Overseas Corp.
Room 1528
Kasumigaseki Bldg.
3-2-5 Kasumigaseki,
Chiyoda-Ku
Tokyo 100, Japan
3 581 9811

Mr. Ernest McCrary
Empresa Internacional de
Comunicacoes Ltda.
Rua da Consolacao, 222
Conjunto 103
01302 Sao Paulo, S. P., Brasil
Tel: (11) 259-3811
Telex: (100) 32122 EMBN

READER SERVICE

To get further information on the products advertised in BYTE, fill out the reader service card by circling the numbers on the card that correspond to the inquiry number listed with the advertiser. This index is provided as an additional service by the publisher, who assumes no liability for errors or omissions.

* Correspond directly with company.

Index to Advertisers by Product Category

Inquiry No.	Page No.	Inquiry No.	Page No.	Inquiry No.	Page No.	Inquiry No.	Page No.
HARDWARE							
800	ADD INS	406 CIS	96IS-56	313 RAINBOW TECH.	105	318 NATIONAL INSTRUMENTS	145
19 ALPHA PRODUCTS CO.	348,349	57 CIS (LEE YUAN CO.)	54	314 RAINBOW TECH.	105	211 PATTON & PATTON	122
23 AMS	344	202 OVERLAND DATA	336	813 SYSTEMS			
30 ATITECHNOLOGIES	35	232 QUALSTAR CORP.	335	401 ACME TECHNOLOGY	96IS-54	217 PERSONAL TEX	274
403 BEST COMMUNICATION	96IS-55	291 VERBATIM CORPORATION	153	14 ADVANCED LOGIC RES.	76,77	264 SPECTRUM	81
405 BLUE CHIP TECHNOLOGY	96IS-30	MISCELLANEOUS		15 ADVANCED LOGIC RES.	76,77	265 STATSOFT	113
50 B&C MICROSYSTEMS	337	* ANTHRO	42	* AMPRO	200	267 SUNFLEX	143
51 B&C MICROSYSTEMS	337	91 ENGINEERS COLLABORATIVE	337	26 AST RESEARCH	185-187	268 SUNFLEX	143
55 CAPITAL EQUIPMENT	120	121 HARRIS/3M	154,155	27 AST RESEARCH	185-187	272 SYSTAT	271
56 CAPITAL EQUIPMENT	121	420 IN WIN DEVELOPMENT	96IS-55	37 BEST COMPUTER	140	273 SYSTAT	271
68 CONTROL SYSTEMS	248B	* INECTRA INC	337	539 BUSINESS MICRO SYS.	96MW-17	IBM/MSDOS—CAD	
69 CONTROL SYSTEMS	248B	135 INTEGRAND	174	540 BUSINESS MICRO SYS.	96MW-17	22 AMERICAN SM. BUS. COMP.	287
70 CONTROL VISION	336	428 KADOR	96IS-30	66 COMPUTRADE	100	100 FORESIGHT RESOURCES	39
72 CVOX	334	184 MICROTECH CONV. SYS.	337	506 COMTEQ COMP. CORP.	96SO-11	101 FORESIGHT RESOURCES	39
408 CUBIX	96IS-17	554 N VIEW	96MW-1	* DELL COMPUTER	44A,B	300 WINTEK	5
331 DIVERSIFIED TECHNOLOGY	342	245 RCS	54	77 DELL COMPUTER	CI1,1	301 WINTEK	342
411 FORMOSA MICROSYS. INC.	96IS-47	435 RCS TECHNOLOGY CORP.	96IS-51	82 DTK	178	818 IBM/MSDOS—LAN	
112 GENOA SYSTEMS CORP.	253	286 TWIX INT'L	340	83 DTK	178	74 DATA TRANSLATION	33
118 GTEK	310	MODEMS/MULTIPLEXORS		410 ELONEX	96IS-29	555 NET LOGIC	96MW-17
119 GTEK	310	403 BEST COMMUNICATION	96IS-55	93 EVEREX COMPUTER SYS.	28,29	819 IBM/MSDOS—GRAPHICS	
421 INES	96IS-24	* CLEO SOFTWARE	128	94 EVEREX COMPUTER SYS.	28,29	* DAYTRON ELECTRONICS	335
422 INTERQUADRAM	96IS-5	61 COMPUCOM	330	102 FORTRON CORP.	30	113 GENUS	286
423 INTERQUADRAM	96IS-7	499 COWELL CORPORATION	96SO-4	103 FORTRON CORP.	30	480 ISLAND SYSTEMS	96PC-12
424 INTERQUADRAM	96IS-9	500 COWELL CORPORATION	96SO-4	108 GATEWAY 2000	8,9	550 ISLAND SYSTEMS	96MW-2
138 IO TECH	142	277 TELCOR	212	414 GIGA-BYTE	96IS-54	145 KEA SYSTEMS	344
139 IO TECH	336	278 TELEBIT	103	523 HERTZ COMPUTERS	96NE-13	171 MEDIA CYBERNETICS INC.	196
141 JB COMPU-TRONIX	336	284 TOUCHBASE SYSTEMS, INC.	16D	120 HWA HSN ELECTRONIC CO.	84	172 MEDIA CYBERNETICS INC.	196
551 LASER MASTER	96MW-3	289 US ROBOTICS	61	417 HWA HSN ELEC. CO.	96IS-51	212 PAUL MACE SOFTWARE	256
552 LASER MASTER	96MW-3	807 MONITORS		133 IEEE	116	485 P.11 ELECTRONICS	96PC-6
167 MAXON	269	402 BERING INFORMATION CO.	96IS-55	548 ISD	96MW-9	486 P.11 ELECTRONICS	96PC-6
168 MAXON	269	427 INTRA ELECTRONICS CO.	96IS-50	549 ISD	96MW-9	820 IBM/MSDOS—LANGUAGES	
430 MICRON TECH.	96IS-25	178 MICROVITEC	24	132 J-TECH CORP.	344	* CALEND	96IS-27
183 MICROSTAR LABORATORIES	354	179 MICROVITEC	24	524 LOGIX	96NE-8	87 ELLIS COMPUTING	114
187 MIRO DATENSYTTME	273	190 MITSUBISHI	254,255	525 LOGIX	96NE-8	120 HAMMERLY COMP. SERV.	87
432 NEST TECHNOLOGIES	96IS-51	191 MITSUBISHI	254,255	526 LOGIX	96NE-8	136 INTELLITECH	175
556 NEWER TECHNOLOGY	96MW-8	193 NANA0	266	* NEC INFORMATION SYSTEMS	CI11	143 JENSEN & PARTNERS	125
198 NOHAU CORP.	334	194 NANA0	266	228 PC LINK	96NE-7	152 LAHEY COMPUTER SYSTEMS	218
216 PERSONAL SPACE COMM.	336	448 TAIWAN VIDEO & MONITOR	96IS-49	527 PROTEUS TECH. CORP.	27	156 LOGICAL DEVICES	336
230 QUADRAM	248	276 TATUNG	278	242 RADIO SHACK	CIV	157 LOGICAL DEVICES	336
231 QUADRAM	248	808 NETWORK HARDWARE		243 RADIO SHACK	139	162 MANX SOFTWARE SYSTEMS	85
238 QUATECH	342	36 BAYTECH	156	247 RENEGADE TECHNOLOGY	14,15	* MICROSOFT	3
239 QUATECH	342	45 BUFFALO PRODUCTS	259	437 SIEMENS	96IS-21	* MICROSOFT	92,93
240 QUATECH	342	46 BUFFALO PRODUCTS	259	262 SN'W ELECTRONICS	38	253 SAIC	102
241 QUATECH	342	408 CUBIX	96IS-17	440 SUN MICROSYSTEMS	96IS-19	254 SAIC	102
246 REAL TIME DEVICES	337	409 DATEX SYSTEMS	96IS-23	530 TAN COMPUTER	96NE-10	821 IBM/MSDOS—UTILITIES	
261 SILICON	18	154 LAN-MARK SYSTEMS	334	431 TORLINK	96IS-48	10 ABRAXAS SOFTWARE	242
438 SILICON INTEGRATED SYS.	96IS-52	555 NET LOGIC	96MW-17	282 TOSHIBA COMPUTERS	88,89	31 ATRON	64
263 SOTA	21	216 PERSONAL SPACE COMM.	336	283 TOSHIBA COMPUTERS	88,89	41 BLAISE	45
266 SUTABLE SOLUTIONS	354	436 RING DALE PERIPHERALS	96IS-31	442 TRIANGLE DIGITAL	96IS-28	42 BORLAND	69
275 TALKING TECHNOLOGY	340	248 ROSE ELECTRONICS	150	444 UNITRON INC.	96IS-53	43 BORLAND	69
279 TELEBYTE TECHNOLOGY	52	299 WISEMANN & THEIS	126	562 USER FRIENDLY	96MW-23	47 BUMBLEBEE SOFTWARE	52
285 TRUEVISION	173	809 POWER SUPPLIES		560 U.S. MICRO ENG.	96MW-23	407 COMPUSENSE LTD.	96IS-28
801 DRIVES		21 AMERICAN POWER CONVRSN.	138	561 U.S. MICRO ENG.	96MW-23	73 C-SOURCE	289
* SEAGATE	137	504 DRSPower PRODUCTS	96SO-11	293 VNS AMERICA	148,149	* DAYTRON ELECTRONICS	335
271 SYSGEN	16A	505 DRSPower PRODUCTS	96SO-11	294 VNS AMERICA	247	319 FUTURE COMPUTER SYS.	101
297 WELTEK DIGITAL INC.	244	88 EMERSON COMPUTER POWER	181	295 WELLS AMERICAN (DOMESTIC)	31	320 FUTURE COMPUTER SYS.	101
298 WELTEK DIGITAL INC.	244	89 EMERSON COMPUTER POWER	181	296 WELLS AMERICAN (INT'L)	31	115 GOLDEN BOW	205
802 HARDWARE PROGRAMMERS		209 PARA SYSTEMS	167	304 ZENITH	147	116 GOLDEN BOW	205
44 BP MICROSYSTEMS	338	SM INDUSTRIES	96SO-9	305 ZEOS INTERNATIONAL	56,57	478 GOLDEN BOW SYSTEMS	96PC-1
49 BYTEK COMP. CORP.	342	287 T.S.I.	195	SOFTWARE			
50 B&C MICROSYSTEMS	337	288 T.S.I.	195	814 APPLE2/MAC-LANGUAGES			
51 B&C MICROSYSTEMS	337	564 VITEQ	96MW-11	78 DIGITALK	41	146 KNOWLEDGE GARDEN	201
118 GTEK	310	565 VITEQ	96MW-11	815 IBM/MSDOS APPLICATIONS			
119 GTEK	310	810 PRINTERS/PLOTTERS		Business/Office			
147 KORE, INC.	334	518 DATAWARE PRODUCTS	96NE-6	* CW DATA LABS	344	166 MATRIX	59
155 LINK COMPUTER GRAPHICS	340	519 DATAWARE PRODUCTS	96NE-6	104 FOX SOFTWARE	25	192 MIX SOFTWARE	317
158 LOGICAL DEVICES	336	122 HEWLETT PACKARD PERIP.	36,37	105 FTG DATA SYSTEMS	334	557 O.S. ASSOCIATES	96MW-21
159 LOGICAL DEVICES	336	123 HEWLETT PACKARD PERIP.	133	413 GAMMA PRODUCTIONS	96IS-18	558 O.S. ASSOCIATES	96MW-21
302 XELTEK	336	124 HEWLETT PACKARD PERIP.	134	110 GENERIC SOFTWARE	261	214 PERISCOPE	123
803 INSTRUMENTATION		134 IMPACT COMPUTER SYSTEMS	286	111 GENERIC SOFTWARE	261	215 PERISCOPE	123
86 ELEXOR	340	206 PACIFIC DATA PRODUCTS	127	453 MERIDIAN TECHNOLOGY	96IS-41	322 PETER NORTON	16B,16C
330 V3 CORP.	257	451 PACIFIC DATA PROD.	96IS-13	454 MERIDIAN TECHNOLOGY	96IS-41	323 PETER NORTON	16B,16C
804 KEYBOARDS/MICE		452 PACIFIC DATA PROD.	96IS-13	181 MICRORIM	118,119	218 PHAR LAP	46
53 CALCOMP	250	262 SN'W ELECTRONICS	38	182 MICRORIM	118,119	219 POCKETSOFT	95
54 CALCOMP	250	33 VENTURA PERIPHERALS	285	195 NANTUCKET	26	220 POLYTRON	208
* FORTE-COMMUNICATIONS INC.	58	306 ZERICON	131	433 NOVELL DEVELOPMENT	96IS-15	222 PRECISION PLUS SOFTWARE	60
127 HOOLEON	96	307 ZERICON	131	* ORACLE	73	325 PRIME SOLUTIONS	213
128 HOOLEON	96	308 ZERICON	131	228 PROXIMITY	244	326 PRIME SOLUTIONS	213
148 KYE INTERNATIONAL CO.	188	811 SCANNERS/DIGITIZERS		229 PROXIMITY	244	522 SOFTWARE BOTTLING CO.	96NE-15
149 KYE INTERNATIONAL CO.	188	71 CORECO	264	* RAIMA	47	269 SUPERSOFT	28
311 LOGITECH	70,71	96 FLAGSTAFF ENGINEERING	110	292 VERSASOFT CORPORATION	86	VERMONT CREATIVE	10
312 LOGITECH	70,71	97 FLAGSTAFF ENGINEERING	110	832 IBM/MSDOS COMMUNICATIONS			
482 MEXTEL	96PC-2	98 FLAGSTAFF ENGINEERING	110	59 COEFFICIENT SYSTEMS	218	508 COMMUNICATION RES.GRP.	96MW-AT-3
553 MEXTEL	96MW-21	99 FLAGSTAFF ENGINEERING	110	517 COMMUNICATION RES.GRP.	12	81 DIVERSIFIED COMPUTER	340
199 NUMONICS	265	126 HIGH RES TECHNOLOGY	338	822 OTHER APPLICATIONS			
257 SCIENCE ACCESSORIES	277	324 NISCA, INC.	234	Business/Office			
443 UNITECH	96IS-20	329 TRUE DATA PRODUCTS	112	39 BINARY ENGINEERING	275	234 QUARTERDECK	22
805 MASS STORAGE		812 SOFTWARE SECURITY		327 CADRE TECHNOLOGIES, INC.	214	<i>Continued</i>	
17 AK SYSTEMS	340	18 AL ADDIN KNOWLEDGE SYS.	144	85 ECOSOFT	146		
35 BASF	43	225 PROTECH MARKETING	102	120 HAMMERLY COMP. SERV.	87		
40 BIOLOGICAL ENGINEERING	176	226 PROTECH MARKETING	102	129 HORSTMANN SOFTWARE	34		
				165 MATHSOFT	67		
				317 NATIONAL INSTRUMENTS	145		

FREE INFORMATION

Want More Information About the Products and Advertisers Featured in this Issue?

- 1** Circle numbers on reply card which correspond to numbers assigned to items of interest to you.
- 2** Check all the appropriate answers to questions "A" through "C".
- 3** Print your name and address and mail.

Fill out this coupon carefully. PLEASE PRINT.

Name _____

Title _____ (_____) Phone _____

Company _____

Address _____

City _____ State _____ Zip _____

- A. What is your level of management responsibility?**
- Senior-level Management
- Other Management
- Non-Management
- B. What is your primary job function/principal area of responsibility? (Check one.)**
- Administration
- Accounting/Finance
- MIS/DP/Information Center
- Product Design and Development
- Research and Development
- Manufacturing
- Sales/Marketing
- Purchasing
- Personnel
- Education/Training
- Other: _____
- C. Please indicate your organization's primary business activity: (Check one.)**
- Manufacturer (Hardware, Software)
- Computer Retail Stores
- Consultants
- Service Bureau/Planning
- Distributor/Wholesaler
- Systems House/Integrator/VAR
- Other: _____
- Non-Computer-Related Businesses:**
- Manufacturing
- Finance, Insurance, Real Estate
- Retail/Wholesale
- Education
- Government
- Military
- Professions (Law, Medicine, Engineering, Architecture)
- Consulting
- Other Business Services
- Transportation, Communications, Utilities
- Other: _____

APRIL
IRSD002

1	2	3	4	5	6	7	8	9	10	11	12	13	14	15	16	17	18	19	20	21	22	23	24	25	26	27	28	29	30
31	32	33	34	35	36	37	38	39	40	41	42	43	44	45	46	47	48	49	50	51	52	53	54	55	56	57	58	59	60
61	62	63	64	65	66	67	68	69	70	71	72	73	74	75	76	77	78	79	80	81	82	83	84	85	86	87	88	89	90
91	92	93	94	95	96	97	98	99	100	101	102	103	104	105	106	107	108	109	110	111	112	113	114	115	116	117	118	119	120
121	122	123	124	125	126	127	128	129	130	131	132	133	134	135	136	137	138	139	140	141	142	143	144	145	146	147	148	149	150
151	152	153	154	155	156	157	158	159	160	161	162	163	164	165	166	167	168	169	170	171	172	173	174	175	176	177	178	179	180
181	182	183	184	185	186	187	188	189	190	191	192	193	194	195	196	197	198	199	200	201	202	203	204	205	206	207	208	209	210
211	212	213	214	215	216	217	218	219	220	221	222	223	224	225	226	227	228	229	230	231	232	233	234	235	236	237	238	239	240
241	242	243	244	245	246	247	248	249	250	251	252	253	254	255	256	257	258	259	260	261	262	263	264	265	266	267	268	269	270
271	272	273	274	275	276	277	278	279	280	281	282	283	284	285	286	287	288	289	290	291	292	293	294	295	296	297	298	299	300
301	302	303	304	305	306	307	308	309	310	311	312	313	314	315	316	317	318	319	320	321	322	323	324	325	326	327	328	329	330
331	332	333	334	335	336	337	338	339	340	341	342	343	344	345	346	347	348	349	350	351	352	353	354	355	356	357	358	359	360
361	362	363	364	365	366	367	368	369	370	371	372	373	374	375	376	377	378	379	380	381	382	383	384	385	386	387	388	389	390
391	392	393	394	395	396	397	398	399	400	401	402	403	404	405	406	407	408	409	410	411	412	413	414	415	416	417	418	419	420
421	422	423	424	425	426	427	428	429	430	431	432	433	434	435	436	437	438	439	440	441	442	443	444	445	446	447	448	449	450
451	452	453	454	455	456	457	458	459	460	461	462	463	464	465	466	467	468	469	470	471	472	473	474	475	476	477	478	479	480
481	482	483	484	485	486	487	488	489	490	491	492	493	494	495	496	497	498	499	500	501	502	503	504	505	506	507	508	509	510
511	512	513	514	515	516	517	518	519	520	521	522	523	524	525	526	527	528	529	530	531	532	533	534	535	536	537	538	539	540
541	542	543	544	545	546	547	548	549	550	551	552	553	554	555	556	557	558	559	560	561	562	563	564	565	566	567	568	569	570
571	572	573	574	575	576	577	578	579	580	581	582	583	584	585	586	587	588	589	590	591	592	593	594	595	596	597	598	599	600
601	602	603	604	605	606	607	608	609	610	611	612	613	614	615	616	617	618	619	620	621	622	623	624	625	626	627	628	629	630
631	632	633	634	635	636	637	638	639	640	641	642	643	644	645	646	647	648	649	650	651	652	653	654	655	656	657	658	659	660
661	662	663	664	665	666	667	668	669	670	671	672	673	674	675	676	677	678	679	680	681	682	683	684	685	686	687	688	689	690
691	692	693	694	695	696	697	698	699	700	701	702	703	704	705	706	707	708	709	710	711	712	713	714	715	716	717	718	719	720
721	722	723	724	725	726	727	728	729	730	731	732	733	734	735	736	737	738	739	740	741	742	743	744	745	746	747	748	749	750
751	752	753	754	755	756	757	758	759	760	761	762	763	764	765	766	767	768	769	770	771	772	773	774	775	776	777	778	779	780
781	782	783	784	785	786	787	788	789	790	791	792	793	794	795	796	797	798	799	800	801	802	803	804	805	806	807	808	809	810
811	812	813	814	815	816	817	818	819	820	821	822	823	824	825	826	827	828	829	830	831	832	833	834	835	836	837	838	839	840
841	842	843	844	845	846	847	848	849	850	851	852	853	854	855	856	857	858	859	860	861	862	863	864	865	866	867	868	869	870
871	872	873	874	875	876	877	878	879	880	881	882	883	884	885	886	887	888	889	890	891	892	893	894	895	896	897	898	899	900
901	902	903	904	905	906	907	908	909	910	911	912	913	914	915	916	917	918	919	920	921	922	923	924	925	926	927	928	929	930
931	932	933	934	935	936	937	938	939	940	941	942	943	944	945	946	947	948	949	950	951	952	953	954	955	956	957	958	959	960
961	962	963	964	965	966	967	968	969	970	971	972	973	974	975	976	977	978	979	980	981	982	983	984	985	986	987	988	989	990
991	992	993	994	995	996	997	998	999	1000	1001	1002	1003	1004	1005	1006	1007	1008	1009	1010	1011	1012	1013	1014	1015	1016	1017	1018	1019	1020
1021	1022	1023	1024	1025	1026	1027	1028	1029	1030	1031	1032	1033	1034	1035	1036	1037	1038	1039	1040	1041	1042	1043	1044	1045	1046	1047	1048	1049	1050
1051	1052	1053	1054	1055	1056	1057	1058	1059	1060	1061	1062	1063	1064	1065	1066	1067	1068	1069	1070	1071	1072	1073	1074	1075	1076	1077	1078	1079	1080
1081	1082	1083	1084	1085	1086	1087	1088	1089	1090	1091	1092	1093	1094	1095	1096	1097	1098	1099	1100	1101	1102	1103	1104	1105	1106	1107	1108	1109	1110
1111	1112	1113	1114	1115	1116	1117	1118	1119	1120	1121	1122	1123	1124	1125	1126	1127	1128	1129	1130	1131	1132	1133	1134	1135	1136	1137	1138	1139	1140
1141	1142	1143	1144	1145	1146	1147	1148	1149	1150	1151	1152	1153	1154	1155	1156	1157	1158	1159	1160	1161	1162	1163	1164	1165	1166	1167	1168	1169	1170
1171	1172	1173	1174	1175	1176	1177	1178	1179	1180	1181	1182	1183	1184	1185	1186	1187	1188	1189	1190	1191	1192	1193	1194	1195	1196	1197	1198	1199	1200

Please send me one year of BYTE Magazine for \$24.95 and bill me. Offer valid in U.S. and possessions only.



NO POSTAGE
NECESSARY
IF MAILED
IN THE
UNITED STATES

BUSINESS REPLY MAIL
FIRST CLASS MAIL PERMIT NO. 176 PITTSFIELD, MA

POSTAGE WILL BE PAID BY ADDRESSEE



READER SERVICE
PO Box 5110
Pittsfield, MA 01203-9926
USA



FREE INFORMATION

Want More Information About the Products and Advertisers Featured in this Issue?

- 1** Circle numbers on reply card which correspond to numbers assigned to items of interest to you.
- 2** Check all the appropriate answers to questions "A" through "C".
- 3** Print your name and address and mail.



NO POSTAGE
NECESSARY
IF MAILED
IN THE
UNITED STATES

BUSINESS REPLY MAIL
FIRST CLASS MAIL PERMIT NO. 176 PITTSFIELD, MA

POSTAGE WILL BE PAID BY ADDRESSEE



READER SERVICE
PO Box 5110
Pittsfield, MA 01203-9926
USA



Fill out this coupon carefully. PLEASE PRINT.

Name _____

Title _____ (_____) _____
Phone _____

Company _____

Address _____

City _____ State _____ Zip _____

- A. What is your level of management responsibility? (Check one.)**
- 1 Senior-level Management
 - 2 Other Management
 - 3 Non-Management
- B. What is your primary job function/principal area of responsibility? (Check one.)**
- 1 Administration
 - 2 Accounting/Finance
 - 3 MIS/DP/Information Center
 - 4 Product Design and Development
 - 5 Research and Development
 - 6 Manufacturing
 - 7 Sales/Marketing
 - 8 Purchasing
 - 9 Personnel
 - 10 Education/Training
 - 11 Other: _____
- C. Please indicate your organization's primary business activity: (Check one.)**
- 1 Computer Retail Stores
 - 2 Consultants
 - 3 Service Bureau/Planning
 - 4 Distributor/Wholesaler
 - 5 Systems House/Integrator/VAR
 - 6 Other: _____
- Non-Computer-Related Businesses:**
- 8 Manufacturing
 - 9 Finance, Insurance, Real Estate
 - 10 Retail/Wholesale
 - 11 Education
 - 12 Government
 - 13 Military
 - 14 Professions (Law, Medicine, Engineering, Architecture)
 - 15 Consulting
 - 16 Other Business Services
 - 17 Transportation, Communications, Utilities
 - 18 Other: _____

1	2	3	4	5	6	7	8	9	10	11	12	13	14	15	16	17	18	19	20	21	22	23	24	25	26	27	28	29	30
31	32	33	34	35	36	37	38	39	40	41	42	43	44	45	46	47	48	49	50	51	52	53	54	55	56	57	58	59	60
61	62	63	64	65	66	67	68	69	70	71	72	73	74	75	76	77	78	79	80	81	82	83	84	85	86	87	88	89	90
91	92	93	94	95	96	97	98	99	100	101	102	103	104	105	106	107	108	109	110	111	112	113	114	115	116	117	118	119	120
121	122	123	124	125	126	127	128	129	130	131	132	133	134	135	136	137	138	139	140	141	142	143	144	145	146	147	148	149	150
151	152	153	154	155	156	157	158	159	160	161	162	163	164	165	166	167	168	169	170	171	172	173	174	175	176	177	178	179	180
181	182	183	184	185	186	187	188	189	190	191	192	193	194	195	196	197	198	199	200	201	202	203	204	205	206	207	208	209	210
211	212	213	214	215	216	217	218	219	220	221	222	223	224	225	226	227	228	229	230	231	232	233	234	235	236	237	238	239	240
241	242	243	244	245	246	247	248	249	250	251	252	253	254	255	256	257	258	259	260	261	262	263	264	265	266	267	268	269	270
271	272	273	274	275	276	277	278	279	280	281	282	283	284	285	286	287	288	289	290	291	292	293	294	295	296	297	298	299	300
301	302	303	304	305	306	307	308	309	310	311	312	313	314	315	316	317	318	319	320	321	322	323	324	325	326	327	328	329	330
331	332	333	334	335	336	337	338	339	340	341	342	343	344	345	346	347	348	349	350	351	352	353	354	355	356	357	358	359	360
361	362	363	364	365	366	367	368	369	370	371	372	373	374	375	376	377	378	379	380	381	382	383	384	385	386	387	388	389	390
391	392	393	394	395	396	397	398	399	400	401	402	403	404	405	406	407	408	409	410	411	412	413	414	415	416	417	418	419	420
421	422	423	424	425	426	427	428	429	430	431	432	433	434	435	436	437	438	439	440	441	442	443	444	445	446	447	448	449	450
451	452	453	454	455	456	457	458	459	460	461	462	463	464	465	466	467	468	469	470	471	472	473	474	475	476	477	478	479	480
481	482	483	484	485	486	487	488	489	490	491	492	493	494	495	496	497	498	499	500	501	502	503	504	505	506	507	508	509	510
511	512	513	514	515	516	517	518	519	520	521	522	523	524	525	526	527	528	529	530	531	532	533	534	535	536	537	538	539	540
541	542	543	544	545	546	547	548	549	550	551	552	553	554	555	556	557	558	559	560	561	562	563	564	565	566	567	568	569	570
571	572	573	574	575	576	577	578	579	580	581	582	583	584	585	586	587	588	589	590	591	592	593	594	595	596	597	598	599	600
601	602	603	604	605	606	607	608	609	610	611	612	613	614	615	616	617	618	619	620	621	622	623	624	625	626	627	628	629	630
631	632	633	634	635	636	637	638	639	640	641	642	643	644	645	646	647	648	649	650	651	652	653	654	655	656	657	658	659	660
661	662	663	664	665	666	667	668	669	670	671	672	673	674	675	676	677	678	679	680	681	682	683	684	685	686	687	688	689	690
691	692	693	694	695	696	697	698	699	700	701	702	703	704	705	706	707	708	709	710	711	712	713	714	715	716	717	718	719	720
721	722	723	724	725	726	727	728	729	730	731	732	733	734	735	736	737	738	739	740	741	742	743	744	745	746	747	748	749	750
751	752	753	754	755	756	757	758	759	760	761	762	763	764	765	766	767	768	769	770	771	772	773	774	775	776	777	778	779	780
781	782	783	784	785	786	787	788	789	790	791	792	793	794	795	796	797	798	799	800	801	802	803	804	805	806	807	808	809	810
811	812	813	814	815	816	817	818	819	820	821	822	823	824	825	826	827	828	829	830	831	832	833	834	835	836	837	838	839	840
841	842	843	844	845	846	847	848	849	850	851	852	853	854	855	856	857	858	859	860	861	862	863	864	865	866	867	868	869	870
871	872	873	874	875	876	877	878	879	880	881	882	883	884	885	886	887	888	889	890	891	892	893	894	895	896	897	898	899	900
901	902	903	904	905	906	907	908	909	910	911	912	913	914	915	916	917	918	919	920	921	922	923	924	925	926	927	928	929	930
931	932	933	934	935	936	937	938	939	940	941	942	943	944	945	946	947	948	949	950	951	952	953	954	955	956	957	958	959	960
961	962	963	964	965	966	967	968	969	970	971	972	973	974	975	976	977	978	979	980	981	982	983	984	985	986	987	988	989	990
991	992	993	994	995	996	997	998	999	1000	1001	1002	1003	1004	1005	1006	1007	1008	1009	1010	1011	1012	1013	1014	1015	1016	1017	1018	1019	1020
1021	1022	1023	1024	1025	1026	1027	1028	1029	1030	1031	1032	1033	1034	1035	1036	1037	1038	1039	1040	1041	1042	1043	1044	1045	1046	1047	1048	1049	1050
1051	1052	1053	1054	1055	1056	1057	1058	1059	1060	1061	1062	1063	1064	1065	1066	1067	1068	1069	1070	1071	1072	1073	1074	1075	1076	1077	1078	1079	1080
1081	1082	1083	1084	1085	1086	1087	1088	1089	1090	1091	1092	1093	1094	1095	1096	1097	1098	1099	1100	1101	1102	1103	1104	1105	1106	1107	1108	1109	1110
1111	1112	1113	1114	1115	1116	1117	1118	1119	1120	1121	1122	1123	1124	1125	1126	1127	1128	1129	1130	1131	1132	1133	1134	1135	1136	1137	1138	1139	1140
1141	1142	1143	1144	1145	1146	1147	1148	1149	1150	1151	1152	1153	1154	1155	1156	1157	1158	1159	1160	1161	1162	1163	1164	1165	1166	1167	1168	1169	1170
1171	1172	1173	1174	1175	1176	1177	1178	1179	1180	1181	1182	1183	1184	1185	1186	1187	1188	1189	1190	1191	1192	1193	1194	1195	1196	1197	1198	1199	1200

Please send me one year of BYTE Magazine for \$24.95 and bill me. Offer valid in U.S. and possessions only.

APRIL
IRSD002

POWER TOOLS FOR THE THINKING CLASS.



You're paid to think.

Sure, you play many important roles for your company. But most important, it's the way you think that's taken you this far, this fast.

One way to get a little farther, a little faster, is to consider making the NEC PowerMate[®] 386/20 and PowerMate 2 part of your corporate climb. Because both help you do a faster, more thorough job of working and thinking.

The PowerMate 386/20 is the one for sophisticated users with advanced applications. It's got the muscle and speed (20/8 MHz) to work with all off-the-shelf 386 software, including Windows/386,[™] UNIX[®] and XENIX[®]. The power, storage and memory (up to 16 MB) to function as a file server. And add any one of a broad range of peripherals and you're ready to tackle

complex financial modeling, engineering or designing, as well.

The PowerMate 2 was born to accelerate your climb to the top. It's expandable. It's 80286-based and runs at 10/8 MHz. And it handles the day-to-day chores by delivering more than enough memory (up to 10.6 MB) and storage to breeze through spreadsheets, project management, even desktop publishing.

Naturally, both power tools are part of our complete family of compatible, top-quality PCs. All backed by a \$22 billion company.

To learn more about power tools for the thinking class, call us at 1-800-NEC-INFO. (in Canada, 1-800-343-4418). You'll be making a call that shows you've really done some thinking.

NEC

Tandy Computers: The broadest line of PCs in America.



The Tandy® 4000 LX

Get the power
and performance
of Intel's 80386
...at 20 MHz.

To streamline your heavy business workload, turn to the Tandy 4000 LX. With its 32-bit Intel® 80386 microprocessor operating at 20 MHz, the 4000 LX delivers a new level of performance to database management and sophisticated computer-aided design.

Two megabytes of zero wait-state memory make the 4000 LX ready to use with MS® OS/2, as well as MS-DOS® software. With this much memory standard, the Tandy 4000 LX is also ready to use as the

hub of a powerful multiuser office system running SCO™ XENIX® software. And as a network file server in a 3Com® workgroup, the 4000 LX provides 20 MHz performance for exceptionally high-speed data transfer.

The Tandy 4000 LX is highly expandable. Three front-panel device slots and eight expansion slots give power users the flexibility needed in configuring the optimum system. VGA graphics for desktop publishing, an Intel 80387 math

coprocessor for math-intensive applications and SCSI technology for high-performance disk storage are but a few of the many expansion options available.

The Tandy 4000 LX complements our Tandy 4000—a 386™ machine operating at 16 MHz. The 1MB Tandy 4000 is the cost-effective solution for many high-performance applications.

The new generation Tandy 4000 LX. From the best-selling family of PC compatibles made in America.

Tandy Computers: Because there is no better value™

Intel/Reg. TM and 386/TM Intel Corp. MS, MS-DOS and XENIX/Reg. TM Microsoft Corp. SCO/TM The Santa Cruz Operation. 3Com/Reg. TM 3Com Corp.

Radio Shack®
COMPUTER CENTERS
A DIVISION OF TANDY CORPORATION