

REVIEWS

Portable ATs from
Zenith and Mitsubishi
MASM, Turbo Assembler,
and OPTASM
Tandy 5000 MC
dBASE IV

BYTE

FEBRUARY 1989

A McGRAW-HILL PUBLICATION

The New Mac SE/30

*Mac II power
with
an SE price*

PLUS

Paradox 3
*A Contender
for "Best DBMS"*
Digital Paper
Turbo Windowing
4 Short Takes

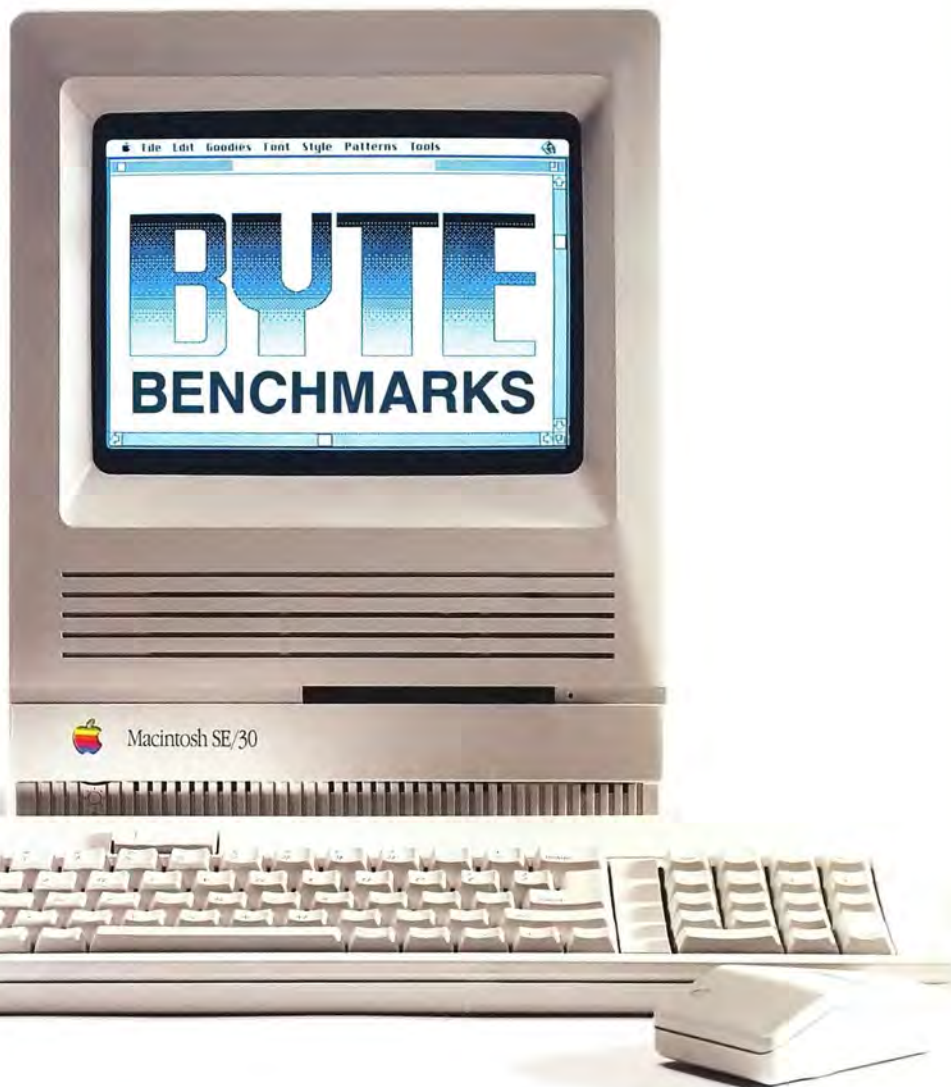

FEBRUARY 1989

BYTE

PERSONAL WORKSTATIONS • C COMPILERS • MAC SE/30

Volume 14, Number 2



\$3.50 U.S.A./\$4.50 IN CANADA
0360-5280

TO ALLAY YOUR SUSPICIONS

YOUR TOTAL SATISFACTION IS GUARANTEED.

Dell offers a complete line of systems, peripherals and software.

And whatever you choose, you must be absolutely, totally satisfied with it. If not, simply return it within the first 30 days for a money-back refund. No questions asked. We call this our Total Satisfaction Guarantee.

SUPPORT IS A FREE PHONE CALL AWAY.

Also included in your system price is our toll-free support line. It's open every business day from 7 AM to 7 PM (CT). Simply dial (800) 624-9896.

ON-SITE SERVICE IS INCLUDED IN YOUR SYSTEM PRICE.

For those rare problems that can't be handled over the phone, we'll send a service technician to your location by the next business day. At absolutely no charge to you. Because included in system price is a year's worth of on-site service.

ONE-YEAR WARRANTY.

Dell offers a one-year limited warranty, which warrants each system we manufacture to be free of defects in materials and workmanship for one full year. During that period we will repair or replace any defective products returned to our factory.

For a lot of companies, leasing our systems is an even better idea because of the cash flow and tax advantages. And we guarantee fixed rates, so you know exactly how much to budget each month. We can even custom design a lease plan to fit the exact needs of your business.

For the complete terms of our On-Site Service Contract, Satisfaction Guarantee, Warranty and leasing plans, write: Dell Computer Corporation, 9505 Arboretum Blvd., Austin, Texas 78759-7299.



THE NEW 25 MHz
386 SYSTEM 325.

When you need the highest possible performance of any 386, this is the technology of choice. Running at 25 MHz, the System 325 is faster than the Compaq 386/25. Besides unequaled speed, it also offers Intel's Advanced 82385 Cache Memory Controller and high performance disk drives. As a result, it gives you workstation-level performance for CAD/CAM and desktop publishing applications. It's also especially effective as a network file server, and more than capable of handling the most complex spreadsheets and databases.

STANDARD FEATURES:

- Intel 80386 microprocessor running at 25 MHz.
- 1 MB of RAM* expandable to 16 MB using a dedicated high speed 32-bit memory slot.
- Advanced Intel 82385 Cache Memory Controller with 32 KB of high speed static RAM cache.
- Page mode interleaved memory architecture.
- VGA systems include a high performance 16-bit video adapter.
- Socket for 25 MHz Intel 80387 or 25 MHz WEITEK 3167 math coprocessor.
- 5.25" 1.2 MB or 3.5" 1.44 MB diskette drive.
- Dual diskette and hard disk drive controller.
- Enhanced 101-key keyboard.
- 1 parallel and 2 serial ports.
- 200-watt power supply.
- 8 industry standard expansion slots.

OPTIONS:

- 25 MHz Intel 80387 math coprocessor.
- 1 MB or 4 MB memory upgrade kit.
- 2 MB or 8 MB memory expansion board kit.

**Lease for as low as \$245/Month.

System 325	With Monitor & Adapter	
Hard Disk Drives	VGA Mono	VGA Color Plus
150 MB-18 ms ESDI	\$6,799	\$7,099
322 MB-18 ms ESDI	\$8,799	\$9,099

The Dell System 325 is an FCC Class A device, intended for business use only.



THE DELL 20 MHz
386 SYSTEM 310.

For business users who need a 386 system, this is the best combination of performance and value available. Running at 20 MHz, this 32-bit system is faster than the IBM PS/2 Model 70 and the Compaq 386/20e. Since it has the same high performance disk drives and Intel Advanced 82385 Cache Memory Controller as our System 325, it brings a new level of performance to complex spreadsheets and databases. As you might expect, it runs windowed software at extremely high speed. It's also well-suited for desktop publishing applications, or as a network file server.

STANDARD FEATURES:

- Intel 80386 microprocessor running at 20 MHz.
- 1 MB of RAM* expandable to 16 MB using a dedicated high speed 32-bit memory slot.
- Advanced Intel 82385 Cache Memory Controller with 32 KB of high speed static RAM cache.
- Page mode interleaved memory architecture.
- VGA systems include a high performance 16-bit video adapter.
- Socket for 20 MHz Intel 80387 or 20 MHz WEITEK 3167 math coprocessor.
- 5.25" 1.2 MB or 3.5" 1.44 MB diskette drive.
- Dual diskette and hard disk drive controller.
- Enhanced 101-key keyboard.
- 1 parallel and 2 serial ports.
- 200-watt power supply.
- 8 industry standard expansion slots.

OPTIONS:

- 20 MHz Intel 80387 math coprocessor.
- 1 MB or 4 MB memory upgrade kit.
- 2 MB or 8 MB memory expansion board kit.

**Lease for as low as \$140/Month.

System 310	With Monitor & Adapter	
Hard Disk Drives	VGA Mono	VGA Color Plus
40 MB-28 ms	\$3,899	\$4,199
90 MB-18 ms ESDI	\$4,699	\$4,999
150 MB-18 ms ESDI	\$5,199	\$5,499
322 MB-18 ms ESDI	\$7,199	\$7,499

PLEASE CALL 800-426-5150.



**THE DELL 20 MHz
286 SYSTEM 220.**

It's an 80286 system that's as fast as most 386 computers. But at less than half the price. Which means you get the best price/performance of any system. The System 220 runs at 20 MHz, with less than one wait state. It also features complete compatibility with Microsoft MS-DOS and MS OS/2, plus a remarkably small footprint. The System 220 is the ideal executive workstation.

STANDARD FEATURES:

- 80286 microprocessor running at 20 MHz.
- 1 MB of RAM* expandable to 16 MB† (8 MB† on system board).
- Page mode interleaved memory architecture.
- Integrated diskette and VGA video controller on system board.
- Socket for Intel 80287 math coprocessor.
- One 3.5" 1.44 MB diskette drive.
- Integrated high performance hard disk interface on system board.
- Enhanced 101-key keyboard.
- 1 parallel and 2 serial ports integrated on system board.
- 3 full-sized industry standard expansion slots available.

OPTIONS:

- External 5.25" 1.2 MB diskette drive.
- 3.5" 1.44 MB diskette drive.
- Intel 80287 math coprocessor.
- 1 MB RAM upgrade kit.

**Lease for as low as \$85/Month.

System 220 Disk Drives	With Monitor	
	VGA Mono	VGA Color Plus
One Diskette Drive	\$2,299	\$2,599
40 MB-29 ms Hard Disk	\$2,999	\$3,299
100 MB-29 ms Hard Disk	\$3,799	\$4,099



**THE DELL 12.5 MHz
SYSTEM 200.**

A great value in a full-featured AT compatible. An 80286 computer running at 12.5 MHz, this computer is completely Microsoft MS-DOS and MS OS/2 compatible. The System 200 offers high speed drive options, industry standard compatible BIOS and on-site service. As Executive Computing said of this computer's predecessor, "If faster processing speed and low cost are two key issues affecting your purchase decision, this machine might be the ideal choice for your office."

STANDARD FEATURES:

- 80286 microprocessor running at 12.5 MHz.
- 640 KB of RAM expandable to 16 MB† (4.6 MB† on system board).
- Socket for Intel 80287 math coprocessor.
- 5.25" 1.2 MB or 3.5" 1.44 MB diskette drive.
- Dual diskette and hard disk drive controller.
- Enhanced 101-key keyboard.
- 1 parallel and 2 serial ports.
- 200-watt power supply.
- 6 industry standard expansion slots.

OPTIONS:

- Intel 80287 math coprocessor.
- 512 KB RAM upgrade kit.

**Lease for as low as \$99/Month.

***PERFORMANCE ENHANCEMENTS
(SYSTEMS 325, 310 AND 220):**

640 KB is available for programs and data. The remaining 384 KB is reserved for use by the system to enhance performance.

†Using 1 MB SIMMs. Inquire as to availability.

System 200 Hard Disk Drives	With Monitor & Adapter	
	VGA Mono	VGA Color Plus
40 MB-28 ms	\$2,699	\$2,999
90 MB-18 ms ESDI	\$3,499	\$3,799
150 MB-18 ms ESDI	\$3,999	\$4,299
322 MB-18 ms ESDI	\$5,999	\$6,299

LASER PRINTERS AND MORE.

The obvious companion for a high performance Dell system is a Dell laser or dot matrix printer. All printers come with 30-day money-back guarantee. And be sure to ask about our software offerings, which include most popular third-party applications as well as Dell Enhanced operating system software.

LASER PRINTERS.

- Laser System 150, 15 pages per minute: \$5,995.
- Laser System 80, 8 pages per minute: \$3,295.
- Laser System 60, 6 pages per minute: \$2,195.

All Dell laser printers come with 1.5 MB RAM, full-page 300 DPI graphics, and have 31 standard fonts (7 resident and 24 down-loadable from diskette). Dell laser printers also provide Hewlett-Packard LaserJet, Epson/FX, IBM Proprinter and Diablo 630 emulations.

DOT MATRIX PRINTERS.

- Printer System 800: \$699.95.

Our highest resolution text and graphics, 24-pin dot matrix printer. Draft quality at 200 cps. Letter quality at 66 cps. Parallel and serial interfaces. Wide carriage.

- Printer System 600: \$499.95.

9-pin dot matrix. Draft quality at 240 cps. Near-letter quality at 60 cps. Parallel interface. Wide carriage.

- Printer System 300: \$199.95.

9-pin dot matrix. Draft quality at 144 cps. Near-letter quality at 36 cps. Four standard fonts. Parallel interface. Narrow carriage.

OPERATING SYSTEM SOFTWARE.

- Dell Enhanced Microsoft® MS-DOS® 3.3: \$99.95
- Dell Enhanced Microsoft MS-DOS 4.0: \$119.95
- (Both MS-DOS versions with disk cache and other utilities)
- Dell Enhanced MS® OS/2 Standard Edition 1.0: \$324.95

TO ORDER, PLEASE CALL

800-426-5150

IN CANADA, CALL 800-387-5752

WHY YOU SHOULD
CONSIDER THE
DELL 386 SYSTEMS,
DESPITE THEIR
SUSPICIOUSLY LOW
PRICES.



Our 386-based systems are priced about 35% less than comparable systems—like Compaq's. Which may make you wonder if we've left something important out. Like high performance.

Well we haven't.

In fact, these are among the fastest 386-based systems available. With more advanced features than you'd get in systems that list for up to \$3000 more.

Like Compaq's.

For instance, our 20 MHz System 310 offers you the best value available in any 386-based system. PC Magazine (6/14/88) describes it as "fast enough to burn the sand off a desert floor."

AND IF THAT SOUNDS FAST, WAIT TILL YOU SEE OUR NEW 25 MHz 386-BASED SYSTEM.

At 25 MHz, our new System 325 offers you the highest possible performance in a 386. Like the System 310, it utilizes the very latest technology, including the Intel 82385 Cache Memory Controller, advanced 32-bit architecture and high performance drives. And of course, both systems are fully IBM PC compatible. (For more detailed specifications, see the inside pages.)

But speed isn't the only reason to buy from us. Or even the best reason.

THE FIRST PERSONAL COMPUTER THAT'S TRULY PERSONAL.

Dell configures systems to your own personal specifications. After an

evaluation of your needs, we'll help you select the features that are right for you. After your system unit is custom built, we'll burn-in everything, add-in boards and all, to make sure the entire system works perfectly.

TOLL-FREE SUPPORT AND ON-SITE SERVICE INCLUDED IN THE PRICE.

Every Dell system includes the Dell System Analyzer, a complete set of diagnostic tools. Which lets Dell's expert technicians resolve problems right over the phone. This toll-free support service is available from 7AM to 7PM (CT) every business day, at no extra charge.

And if your system requires hands-on service, a technician will be at your location the next business day. At absolutely no charge to you. Because included in the price of your system is a full year of on-site service.

But that's not all. You also get our 30-day money-back guarantee. As well as our one-year limited warranty on parts and workmanship.

AND IF YOU STILL THINK YOU GET WHAT YOU PAY FOR, CONSIDER THIS.

When you buy or lease from Dell, you buy directly from our manufacturing facility in Austin, Texas. Which means we eliminate dealer markups, allowing us to give you a lot more 386 for less.

This same principle is behind all the Dell systems. Review them in detail. Then call us at (800) 426-5150 to order the system that's right for you.

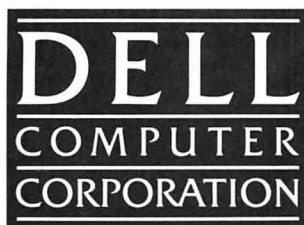

BYTE

FEBRUARY 1989

VOL. 14/NO. 2

PRODUCTS IN PERSPECTIVE

65 What's New

- 97 Short Takes**
MegaMate,
the little drive that could
MKS Make and MKS Lex
and Yacc, *Unix tools for DOS*
Wordbench,
a writer's word processor
DataSentry,
inexpensive data security
Language Systems FORTRAN,
for the Mac forces
Sourcer,
a machine code disassembler



MegaMate/97

- 197 A PS/2 in Channel Only**
by Mark L. Van Name
The Tandy 5000 MC combines PS/2 compatibility with traditional PC features.
- 205 Three Assemblers for MS-DOS**
by Michael Blaszcak
Borland's TASM and OPTASM challenge the long-dominant MASM.
- 211 Full Impact**
by Diana Gabaldon
Ashton-Tate's spreadsheet for the Mac features presentation graphics.

FIRST IMPRESSIONS

- 109 Paradox 3:**
Neither Enigma nor Riddle
by Stan Miastkowski
and Nick Baran
Borland's DBMS is serious competition for dBASE IV.
- 113 Cover Story**
The Mac SE Takes Off
by Nick Baran
The newest version of the Mac SE runs rings around its predecessor.

REVIEWS

- 170 Product Focus:**
Smoothing Out C
by Steve Apiki
and Jon Udell
Optimizing C compilers combine speed, high-level convenience and low-level power.
- 189 A Pair of Sophisticated Laptops**
by John Unger
The Zenith SupersPort 286 and Mitsubishi MP-286L have desktop computing power and convenient laptop size.

- 217 dBASE IV Arrives**
by Malcolm Rubel
An improvement over dBASE III Plus in functionality, power, and ease of use.

EXPERT ADVICE

- 121 Computing at Chaos Manor:**
Ready Line Overload
by Jerry Pournelle
Jerry's COMDEX report and more.
- 139 Applications Plus:**
New Friends and Old
by Ezra Shapiro
Ezra's friends are Framework III, the Canon Cat, and The Perfect Career.
- 145 Down to Business:**
Getting into Bigger LANs
by Wayne Rash Jr.
As your office grows, a traditional central server LAN becomes the obvious choice.



- 151 Macinations:**
Hey Apple, I Need a Laptop
by Don Crabb
The time has come for a portable Mac that doesn't strain arms or credit lines.
- 157 OS/2 Notebook:**
Electing the PM
by Mark Minasi
An inexpensive OS/2 workstation that runs Presentation Manager.
- 163 COM1:**
The ABCs of X-, Y-, and ZMODEM
by Brock N. Meeks
XMODEM has spawned a host of file-transfer protocols, and each has its merits.



◀ **SPECIAL SECTION:**
Personal Workstations/226

IN DEPTH

- 226 Introduction: Personal Workstations**
- 229 Two Worlds Converge**
by Nick Baran
The personal workstation: what you get when you cross a user-friendly workstation with a powerful personal computer.
- 235 The Current Crop**
by Bill Nicholls
Depending on where you start and what you spend, you can turn your personal computer into a workstation.
- 245 Worth the RISC**
by Trevor Marshall and Jane Morrill Tazelaar
The RISC chips now on the market deliver powerful performance at low cost.
- 251 How Fast Is Fast?**
by Bill Kindel
The best way to predict how well a system will perform is to test it yourself.
- 255 Art + 2 Years = Science**
by Phillip Robinson
Surveying the state of the art in personal-workstation graphics.
- 265 Networking with Unix**
by Greg Comeau
NFS and RFS are feasible choices for creating a shared Unix workstation environment.
- 270 The Players**
A guide to the companies offering personal-workstation products.

FEATURES

- 274 Digital Paper**
by Dick Pountain
A new breed of write-once optical media that can store up to a gigabyte on floppy disk-size cartridges.



- 283 Turbo Pascal Windowing System**
by Charles J. Butler
TWindows lets you add windows to all your Turbo Pascal programs.

HANDS ON

- 293 Under the Hood: Hard Disk Interfaces**
by Brett Glass
The interface you pick can dramatically affect your system's performance.
- 301 Some Assembly Required: Trees 'n Keys, Part 2**
by Rick Grehan
Continuing last month's look at keyed file systems, Rick takes a closer look at the data file.

DEPARTMENTS

- 6 Editorial:**
The End of Application Software?
- 11 Microbytes**
- 24 Letters**
- 33 Chaos Manor Mail**
- 38 Ask BYTE**
- 51 Book Reviews**
- 347 Coming Up in BYTE**

READER SERVICE

- 346 Editorial Index by Company**
- 348 Alphabetical Index to Advertisers**
- 350 Index to Advertisers by Product Category**
Inquiry Reply Cards: after **352**

PROGRAM LISTINGS

From BIX: see **298**
From BYTEnet:
call (617) 861-9764
On disk or in print:
see card after **312**

BYTE (ISSN 0360-5280) is published monthly with an additional issue in October by McGraw-Hill, Inc. Postmaster: Send address changes, USPS Form 3579, and fulfillment questions to BYTE Subscriptions, P.O. Box 551, Hightstown, NJ 08520. Second-class postage paid at Peterborough, NH 03458 and additional mailing offices. Postage paid at Winnipeg, Manitoba. Registration number 9321. Printed in the United States of America.

Not responsible for lost manuscripts or photos. Opinions expressed by the authors are not necessarily those of BYTE.

Copyright © 1989 by McGraw-Hill, Inc. All rights reserved. Trademark registered in the United States Patent and Trademark Office.



Subscription questions or problems should be addressed to: BYTE Subscriber Service, P.O. Box 551, Hightstown, NJ 08520.

BYTE

EDITOR IN CHIEF
Frederic S. Langa

PUBLISHER/GROUP VICE PRESIDENT
J. Burt Totaro

OPERATIONS
Glenn Hartwig *Associate Managing Editor*

REVIEWS (Hardware, Software, Product Focus)
Michael Nadeau, *Associate Managing Editor*, Dennis Allen
Senior Technical Editor, Software, Stephen Apiki *Testing*
Editor, BYTE Lab, Stanford Diehl *Testing Editor*, BYTE Lab

NEWS AND TECHNOLOGY (Microbytes, What's New, Short Takes)
Rich Malloy *Associate Managing Editor*, D. Barker *Senior*
Editor, News and Technology, Anne Fischer *Lent Senior*
Editor, New Products, Andrew Reinhardt *Associate News*
Editor

Peterborough: Roger Adams *Associate News Editor*, David
Andrews *Associate News Editor*, Martha Hicks *Associate*
News Editor

West Coast: Gene Smarte *Bureau Chief*, Costa Mesa,
Nicholas Baran *Technical Editor*, San Francisco, Frank
Hayes *Associate News Editor*, Marlene Nesary *Associate*
News Editor, Jeffrey Bertolucci *Editorial Assistant*, San
Francisco

SENIOR TECHNICAL EDITORS
Ken Sheldon *Features*, Jane Morrill *Tazelaar In Depth*,
Richard Grehan *At Large*, Tom Thompson *At Large*

TECHNICAL EDITORS
Janet J. Barron, Janet Fiderio, Robert Mitchell, Ben Smith,
Jon Udell, Stanley Wszola

CONSULTING EDITORS
Jerry Pournelle, Ezra Shapiro, Don Crabb, Brett Glass,
Brock N. Meeks, Mark Minasi, Wayne Rash Jr.

CONTRIBUTING EDITORS
Jonathan Amsterdam *Programming Projects*, Mark
Dahmke *Video, Operating Systems*, Mark Haas *At Large*,
Rik Jadricek *CAD, Graphics, Spreadsheets*, Robert T.
Kurosaka *Mathematical Recreations*, Alastair J. W. Mayer
Software, Stan Miastkowski *New Technology*, Alan R.
Miller *Languages and Engineering*, Dick Pountain
Algorithms, Roger Powell *Computers and Music*, Phillip
Robinson *Semiconductors*, Jon Shiell *High-Performance*
Systems, George A. Stewart, *Book Reviews*, Ernest Tello
Artificial Intelligence

COPY EDITORS
Lauren Stickler *Chief*, Susan Colwell, Jeff Edmonds, Judy
Grehan, Nancy Hayes, Cathy Kingery, Margaret A.
Richard, Warren Williamson

EDITORIAL ASSISTANTS
Peggy Dunham *Office Manager*, Linda C. Ryan, June N.
Sheldon, Lynn Susan Valley

ART
Nancy Rice *Director*, Joseph A. Gallagher *Assistant*
Director, Jan Muller *Assistant*, Alan Easton *Technical Artist*

PRODUCTION
David R. Anderson *Director*, Virginia Reardon
Senior Editorial Production Coordinator, Barbara Busenbark
Editorial Production Coordinator, Denise Chartrand *Editorial*
Production Coordinator, Michael J. Lonsky *Editorial*
Production Coordinator

TYPOGRAPHY
Sherry Fiske *Systems Manager*, Donna Sweeney
Applications Manager, Christa Patterson

ADVERTISING/PRODUCTION (603) 924-6448
Lisa Wozmak *Director*, Lyda Clark *Senior Account*
Coordinator, Karen Cilley, Linda Fluhr, Jeanne Gatcombe,
Rod Holden, Wai Chiu Li *Quality Control Manager*, Julie
Murphree *Advertising/Production Coordinator*

ADMINISTRATION
Donna Nordlund, *Publisher's Assistant*

MARKETING COMMUNICATIONS
Horace T. Howland *Director*, Pamela Petrakos-Wilson
Promotion Manager, Wilbur S. Watson *Marketing Services*
Manager, Dawn Matthews *Public Relations Manager*, Lisa
Jo Steiner *Assistant Promotion Manager*, Stephanie
Warnesky *Marketing Art Director*, Sharon Price *Associate*
Art Director, Julie Perron *Market Research Analyst*

PLANNING AND RESEARCH
Michele Perron *Director*
Faith Kluntz *Copyrights Coordinator*, Cynthia Damato
Sands Reader Service Coordinator

FINANCIAL SERVICES
Philip L. Penny *Director of Finance and Services*, Kenneth
A. King *Business Manager*, Christine Monkton *Assistant*,
Marilyn Parker, Diane Henry, JoAnn Walter, Jaime Huber

CIRCULATION
Dan McLaughlin *Director*
James Bingham *Newsstand Sales Manager*, Vicki Weston
Assistant Manager, Karen Desroches *Distribution*
Coordinator, Donna Healy, *Direct Accounts Coordinator*,
Louise Menegus *Back Issues*

PERSONNEL
Patricia Burke *Personnel Coordinator*, Beverly Goss
Receptionist

BUILDING SERVICES
Tony Bennett *Manager*, Cliff Monkton, Mark Monkton,
Agnes Perry

BIX BYTE INFORMATION EXCHANGE

DIRECTOR
Stephen M. Laliberte

EXECUTIVE EDITOR
George Bond

ASSOCIATE EDITOR
Tony Lockwood

MICROBYTES DAILY
D. Barker *Coordinator*, Peterborough, Rich Malloy *New*
York, Gene Smarte *Costa Mesa*, Nicholas Baran *San*
Francisco, Rick Cook *Phoenix*, Frank Hayes *San Francisco*,
Jason Levitt *Austin, TX*, Larry Loeb *Wallingford, CT*, Brock
N. Meeks *La Mesa, CA*, Stan Miastkowski *Peterborough*,
Wayne Rash Jr., Sue Rosenberg *Washington, DC*, David
Reed *Lexington, KY*

GROUP MODERATORS
David Allen *Applications*, Frank Boosman *Artificial*
Intelligence, Leroy Casterline *Other*, Marc Greenfield
Programming Languages, Jim Howard *Graphics*, Gary
Kendall *Operating Systems*, Steve Krenek *Computers*,
Brock N. Meeks *Telecommunications*, Barry Nance *New*
Technology, Donald Osgood *Computers*, Sue Rosenberg
Other, Jon Swanson *Chips*

BUSINESS AND MARKETING
Patricia Bausum *Secretary*, Denise A. Greene *Customer*
Service, Brian Warnock *Customer Service*, Tammy Burgess
Customer Credit and Billing

TECHNOLOGY
Clayton Lisle *Director*, *Business Systems Technology*,
ISCO., Fred Strauss *Senior Business Systems Analyst*

ADVERTISING SALES
Steven M. Vito *Associate Publisher*,
Vice President of Marketing

Dennis J. Riley *Eastern Regional Sales Manager*
Sandra Foster *Administrative Assistant*

Jennifer L. Bartel *West Coast Sales Manager*, (214) 644-1111

NEW ENGLAND
ME, NH, VT, MA, RI, ONTARIO, CANADA &
EASTERN CANADA
John C. Moon (617) 262-1160

ATLANTIC
NY, NYC, CT, NJ (NORTH)
Leah G. Rabinowitz (212) 512-2096
Ken Tashly (212) 512-2645

EAST
PA, KY, NJ (SOUTH), MD, W. VA,
DE, DC
Thomas J. Brun (215) 496-3833

SOUTHEAST
NC, SC, GA, FL, AL, TN, VA
Thomas H. Tolbert (404) 252-0626

MIDWEST
IL, MO, KS, IA, ND, SD, MN, WI, NE, IN, MI, MS, OH
(312) 751-3740

SOUTHWEST, ROCKY MOUNTAIN
CO, WY, OK, TX, AR, LA, UT
Karl Heinrich (713) 462-0757
Dan Harper, *Sales Associate*, (603) 924-2598

SOUTH PACIFIC
SOUTHERN CA, AZ, NM, LAS VEGAS
Jack Anderson (603) 924-6292
Tom Harvey (213) 480-5243

NORTH PACIFIC
HI, WA, OR, ID, MT, NORTHERN CA, NV (except
LAS VEGAS), WESTERN CANADA
Bill McAfee (408) 879-0371
Christine Kopec (415) 362-4600
Elisa Lister, *Sales Associate*, (603) 924-2598

TELEMARKETING
L. Bradley Browne *Director*
Susan Boyd *Administrative Assistant*

SPECIAL ISSUES
Liz Coyman (603) 924-2518

BYTE BITS (2x3)
Mark Stone (603) 924-6830

THE BUYER'S MART (1x2)
Brian Higgins (603) 924-3754

REGIONAL ADVERTISING SECTIONS
Scott Gagnon (603) 924-4380
Larry Levine (603) 924-4379
Barry Echavarrria (603) 924-2574

BYTE POSTCARD DECK MAILINGS

BYTE DECK
Ed Ware (603) 924-6166

COMPUTING FOR DESIGN & CONSTRUCTION
COMPUTING FOR ENGINEERS
Mary Ann Goulding (603) 924-9281

INTERNATIONAL ADVERTISING SALES STAFF
See listing on page 349.

EDITORIAL AND BUSINESS OFFICE:

One Phoenix Mill Lane, Peterborough, NH 03458, (603) 924-9281.
West Coast Branch Offices: 425 Battery St., San Francisco, CA 94111, (415) 954-9718; 3001 Red Hill Ave.,
Building #1, Suite 222, Costa Mesa, CA 92626, (714) 557-6292.
New York Branch Editorial Office: 1221 Avenue of the Americas, New York, NY 10020, (212) 512-3175.
BYTEnet: (617) 861-9764 (set modem at 8-1-N or 7-1-E; 300 or 1200 baud).
Fax: (603) 924-7507. **Telex:** (603) 924-7861.
SUBSCRIPTION CUSTOMER SERVICE: Outside U.S. (609) 426-7070; Inside U.S. (800) 525-5003.
For a new subscription—(800) 257-9402 U.S. only, or write to BYTE Subscription Dept., P.O. Box 555,
Hightstown, NJ 08520.

Officers of McGraw-Hill Information Services Company: President: Walter D. Serwatka. Executive
Vice Presidents: Kenneth E. Gazzola, Aerospace and Defense; Ira Herenstein, Computers
and Communications; Russell C. White, Construction; Robert P. McGraw, Healthcare; Brian H. Hall,
Legal. Senior Vice Presidents—Publishers: Laurence Altman, Data Communications; David J. McGrath,
Engineering News-Record. Senior Vice Presidents: Robert D. Daleo, Finance; Michael J. Koeller, Human
Resources. Group Vice Presidents: J. Burt Totaro, BYTE; Norbert Schumacher, Energy/Process Industries.
Vice Presidents: George Elsinger, Circulation; Julia Lenard, Systems Planning and Technology.

Officers of McGraw-Hill, Inc.: Joseph L. Dionne, Chairman, President, and Chief Executive Officer; Robert
N. Landes, Executive Vice President, General Counsel, and Secretary; Robert J. Bahash, Executive Vice
President and Chief Financial Officer; Frank D. Penglase, Senior Vice President, Treasury Operations.

Founder: James H. McGraw (1860–1948). Executive, editorial, circulation, and advertising offices: One
Phoenix Mill Lane, Peterborough, NH 03458, phone (603) 924-9281. Office hours: Monday through Thursday
8:30 AM–4:30 PM, Friday 8:30 AM–1:00 PM, Eastern Time. Address subscriptions to BYTE Subscriptions,
P.O. Box 551, Hightstown, NJ 08520. Subscriptions are \$29.95 for one year, \$54.95 for two years, and \$74.95
for three years in the U.S. and its possessions. In Canada and Mexico, \$31.95 for one year, \$59.95 for two
years, \$79.95 for three years. \$75 for one-year air delivery to Europe. \$28,800 for one-year air delivery to
Japan, \$14,400 for one-year surface delivery to Japan, \$45 surface delivery elsewhere. Air delivery to
selected areas at additional rates upon request. Single copy price is \$3.50 in the U.S. and its possessions,
\$3.95 in Canada, \$4.50 in Europe, and \$5 elsewhere. Foreign subscriptions and sales should be remitted in
U.S. funds drawn on a U.S. bank. Please allow six to eight weeks for delivery of first issue. Address editorial
correspondence to: Editor, BYTE, One Phoenix Mill Lane, Peterborough, NH 03458. Unacceptable
manuscripts will be returned if accompanied by sufficient postage. Where necessary, permission is granted by
the copyright owner for libraries and others registered with the Copyright Clearance Center (CCC) to
photocopy any article herein for the flat fee of \$1.50 per copy of the article or any part thereof.
Correspondence and payment should be sent directly to the CCC, 29 Congress St., Salem, MA 01970.
Specify ISSN 0360-5280/83, \$1.50. Copying done for other than personal or internal reference use without
the permission of McGraw-Hill, Inc., is prohibited. Requests for special permission or bulk orders should be
addressed to the publisher. BYTE is available in microform from University Microfilms International, 300
North Zeeb Rd., Dept. PR, Ann Arbor, MI 48106 or 18 Bedford Row, Dept. PR, London WC1R 4EJ, England.

BYTE and **BYTE** are registered trademarks of McGraw-Hill, Inc.

smARTWORK® Keeps Getting Smarter



Smarter Artwork

Three years ago, Wintek engineers created smARTWORK to reduce the time and tedium of laying out their own printed-circuit boards. Thousands of engineers have since discovered the ease of use and sophistication that makes smARTWORK the most popular PCB CAD software available. And thanks to them, smARTWORK keeps getting better.



smARTWORK transforms your IBM PC into a PCB CAD system

Interactive routing, continual design-rule checking, pad shaving, and production-quality 2X artwork have always been a part of smARTWORK. And now that many customer suggestions have become a part of the software, smARTWORK is an even better value. That's why we offer it with a thirty-day money-back no-nonsense guarantee.

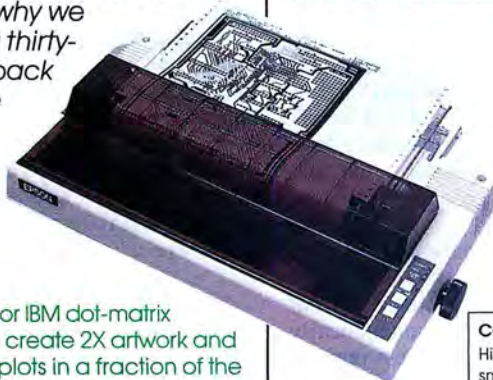

Using an Epson or IBM dot-matrix printer, you can create 2X artwork and 1X or 2X checkplots in a fraction of the time hand-taping requires

New smARTWORK Features

- Silkscreen layer for component placement and identification
- Text capabilities for all three layers
- Selectable trace widths and pad shapes and sizes
- User-definable library
- Ground planes created with a single command
- Solder-mask and padmaster plots generated automatically
- Quick printer 2X checkplots
- Additional drivers for printers and plotters
- Optional drill-tape and Gerber photoplotter utilities
 - AutoCAD® .DXF file output
 - Completely updated manual
 - 800 number for free technical assistance

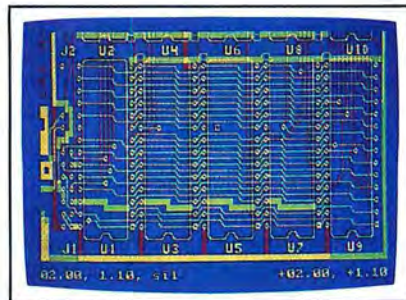

2" by 4" section of a 10" by 16" double-sided board with silkscreen layer

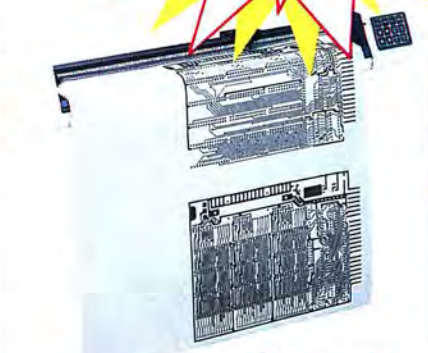

Camera-ready 2X artwork from an HI or HP pen plotter

The Smart Buy. Guaranteed.

Still priced at \$895, smARTWORK is proven, convenient, and fast. Our money-back guarantee lets you try smARTWORK for 30 days at absolutely no risk. Call toll free (800) 742-6809 today and put smARTWORK to work for you tomorrow. That's smart work.

System Requirements

- IBM PC, PC XT, or PC AT with 384K RAM, and DOS V2.0 or later
- IBM Color/Graphics Adapter with RGB color or B&W monitor
- IBM Graphics Printer or Epson FX/MX/RX-series printer, and/or
- Houston Instrument DMP-40, 41, 42, 51, 52, or Hewlett-Packard 7470, 7475, 7550, 7580, 7585, 7586 pen plotter
- Optional Microsoft Mouse

Wintek Corporation
 1801 South St.
 Lafayette, IN 47904
 Telephone: (800) 742-6809
 In Indiana: (317) 742-8428
 Telex: 70-9079 WINTEK CORP UD



"smARTWORK", "Wintek", and the Wintek logo are registered trademarks of Wintek Corporation. "AutoCAD" is a registered trademark of Autodesk, Inc.

Current Versions	
HIWIRE	V1.1r1
smARTWORK	V1.3r5

THE END OF APPLICATION SOFTWARE?

IBM and Microsoft have some very interesting plans for OS/2, PM, and DOS

Several weeks ago, IBM invited a handful of editors to its facility in Hursley, England, where most of Big Blue's work on user interfaces goes on. The announced focus of the discussions was to be Presentation Manager (PM), but it ended up being considerably more than that, expanding to encompass the entire future of OS/2. It's a centralized, uniform future, radically different from the DOS-based world.

Part of the standardization derives from the fact that PM is a piece of IBM's Systems Application Architecture. With PM, SAA has moved squarely into the personal computer arena.

SAA is centered on four key concepts: a Common User Interface, a Common Programming Interface, Common Communications Support, and Common Applications. (The Hursley group is responsible for the CUI.)

All this uniformity portends extreme portability among IBM system software and applications, from OS/2 Extended Edition (described as "IBM's personalization of the generic OS/2 operating system") through OS/400, and up to VM and VME.

OS/2 EE's components already come close to SAA standards. (Actually, because SAA itself will evolve, it's not a "standard" in the strict sense of the word; it's more a goal or a guideline.) OS/2 will become more tightly meshed

with SAA over time. For example, the database manager portion of OS/2 EE embodies about 90 percent of the functions of Structured Query Language (SQL); future versions will raise that to 100 percent.

If IBM has its way, SAA standardization will be far-reaching: For example, virtually all data will end up in a central SQL repository, which all applications will access via the built-in database manager. This way, the data generated by any application anywhere in a system of networked machines will become accessible by all other applications on all the other machines, as well.

SAA's shared data, cooperative applications, and shared peripherals means that—in theory—everyone using Big Blue's software and hardware (and, one presumes, close clones) will see a "single system image." Everyone has access to everything, and everyone can work together easily, regardless of whether they're on a PS/2 or a 370.

IBM accepts the oft-quoted statistics that claim that by 1991, 85 percent of all PCs will be interconnected. IBM sees this as an argument in favor of a central repository—all data becomes accessible to all machines on the network. Users neither care nor need to know where the data is located; the system handles it all.

Is this software fascism? Well, no; the storing of code and data in separate files won't go away (especially for individual program code). IBM's John Soyring said that "other types of files would be allowed" so that programs wouldn't have to use the central repository, but that IBM would simply "encourage" the use of SQL facilities.

It's interesting to note that Borland's not-yet-released Paradox SQL partially fits this pattern: It can function as a front end, or preprocessor, that automatically generates SQL queries to access remote, centralized data. As such, it may be a bellwether for a new kind of application program that we'll be seeing a lot more

of: one in which a vendor carves a niche for a product with added-value special features (like a superior query-by-example facility), but relies on standardized system resources (like a central SQL data store) when they're available.

Under PM, the standardized resources can also include the user interface, communications, and more. It may sound somewhat Mac-like, but under IBM's scheme, the commonality is much wider, extending even across architectures and operating systems.

This is a far cry from the state of DOS applications today, where programmers often continuously reinvent the wheel: Each application may have its own little presentation manager, its own little communications manager, and so on. With these major pieces standardized and readily available at all levels throughout a business, applications programming becomes simpler. Soyring puts it this way: "Programming will become macro writing." Programmers won't have to spend time developing the raw materials of their applications; instead, they "can concentrate on pure functionality, and their productivity will increase."

The thought was echoed by Microsoft's Steve Ballmer. Because of PM's object orientation, "Applications will become objects," he said, "and they'll simply call other applications to use their services. Programming will just be writing scripts in an external control language to use the various objects." If that happens, it will be the end of stand-alone applications as we now know them.

Except under DOS. Next month, I'll talk about IBM's and Microsoft's plans for DOS, and their plans for Unix and an 80386-specific version of OS/2.

—Fred Langa
Editor in Chief
(BIX name "flanga")

INTERACTIVE
386/ix

**✓ The Choice is Clear.**

UNIX[®] Checklist

for 386 systems

- Leading Edge Technology:** First to bring UNIX to 386, first to bring MS-DOS to UNIX, first with X Window, NFS and host-based TCP/IP for the 386.
- Optimized For Business:** Mature and popular environment supporting thousands of commercial applications. Backed by comprehensive support and training.
- Standard:** UNIX System V certified. Committed to meet emerging POSIX and X/OPEN standards. MS-DOS[®] and XENIX[®] applications run, too.
- Outstanding Industry Track Record:** UNIX technology supplier to IBM, Int AT&T, Prime, NCR, Microsoft, Wang, Apollo and others.
- Excellent Price/Performance:** Attractive pricing and discove

INTERACTIVE

A KODAK COMPANY

1-800-537-5324

INTERACTIVE
Systems Corporation
2401 Colorado Avenue
Santa Monica, CA
90404

UNIX is a registered trademark of AT&T.
386/ix is a trademark of INTERACTIVE
Systems Corporation.
MS-DOS and XENIX are registered
trademarks of Microsoft Corporation.
©1988 INTERACTIVE Systems Corporation.

REPLACE YO



PC WORLD
"Upgrade product of the year."
...PC World

"Editors' choice"
...PC Magazine



Installed in minutes, the Renegade 386™ motherboard turns any IBM PC, XT, AT or inexpensive clone into a powerful new computer, lightning fast with both old software AND new OS/2 releases.

Is this you? You would like to have extraordinary computing speed and power. You want number crunching ability. You need complex CAD capabilities. Or graphics. Or multi-tasking.

And you haven't got it. (And you don't want to spend a fortune to replace good equipment with the newest standard.)

Weep no more. You can turn your *present* system into the latest, high-performance system that will *equal or exceed the best of the new computers*.

Renegade 386™ A new heart and brain for your computer.

Renegade Technologies offers designers, engineers, architects, and computer-dependent businesses a simple and reliable alternative to obsolescence. Or the unreasonable expense of a new system.

Simply replace the "motherboard" of your present system with a Renegade 386™ motherboard.

It takes a screwdriver and less than 20 minutes. And costs but \$1695.

That's *thousands of dollars less* than a new IBM System/2 Model 80.

But it gives you more than just the latest industry standard. You can run your old software on it. Probably anything you now use on your XT or AT. Big Blue can't do that.

You can use your present 16-bit peripherals. (If you've looked at PC "add-on" cards, you already know your old equipment would be useless.)

But with Renegade 386™ you'll have to find some other excuse to throw away your current modem, network card,



Multi-task with Lotus 1-2-3 and other applications running side-by-side on the Microsoft Windows/386 desktop.

EGA or disk controller cards.

The Renegade 386™ board comes with an iron-clad *one year limited warranty*. It uses genuine U.S. made Intel 386 chips and is designed and manufactured in the U.S.A. by Hauppauge Computer Works. Hauppauge is a major developer of software

support for Microsoft and IBM products, and is producer of the highly respected Hauppauge 8087 or 80287 highspeed math coprocessors. Over 50,000 have been sold.

Major computer magazine reviews in the last year have hailed our Hauppauge-made board as a major breakthrough in a high speed, high power, high performance upgrade product.

Not an accelerator card. Not a "turbo" gimmick. Renegade 386™ gives you a full-featured new computer.

Thanks to Renegade's 80386 microprocessor your computer will now boast a 32-bit data path—and a clock speed of 16 MHz with zero wait state access. Up to 8 expansion slots are provided depending on your computer configuration.

Your "new" computer also will now have 1 Megabyte of 100ns RAM. This is *not* a naked board. And it also includes a 32-bit high-speed RAM expansion slot which you can populate with up to *15 Mbytes* of system memory.

UR MOTHER

In practical terms that simply means that programs like Lotus 1-2-3 or new products like Foxbase 386, and almost anything else, *will run faster than anything you have ever seen.*

Which is a minor problem for some folks who are playing computer games on company time. Renegade 386™ may run them at speeds far too fast for human reactions.

The world is not perfect.

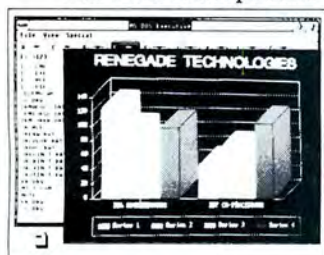

Faster, easier presentation graphics with newest software releases.

Otherwise Renegade 386™ is perfectly compatible with products like AutoCAD, Aldus PageMaker, Microsoft Windows, Ventura Publisher, the Novell Network and sizzlers like Paradox 386. We haven't yet found a popular program we can't run with it.

Power hungry? Equip Renegade 386™ with even more RAM—without speed loss.

Add up to 15 Mbytes of system memory with Renegade™ expansion modules that plug right into your Renegade 386™ 32-bit expansion slot. *And run with no loss of speed*—something no IBM or Compaq model can match.

There's a lot of confusion in computer claims, but the fact is that with *zero* wait state, our 16 MHz is effectively the same as those highly touted machines running at 20 MHz with one wait state.

So plug in Renegade™ expansion modules in 2- and 4-Megabyte increments and run Windows 386 applications at the speed God intended.

386 MotherBoard for the PC or PC/XT\$1695
386 MotherBoard for the PC/AT\$1795
386 MotherBoard/20 MHz for PC/AT\$2195
32-bit RAM Board (2Mbyte installed; up to 10 Mbytes)	\$1195
16 MHz 80387 math coprocessor\$695
16-bit combination hard disk/floppy disk controller	\$245

Prices subject to change.

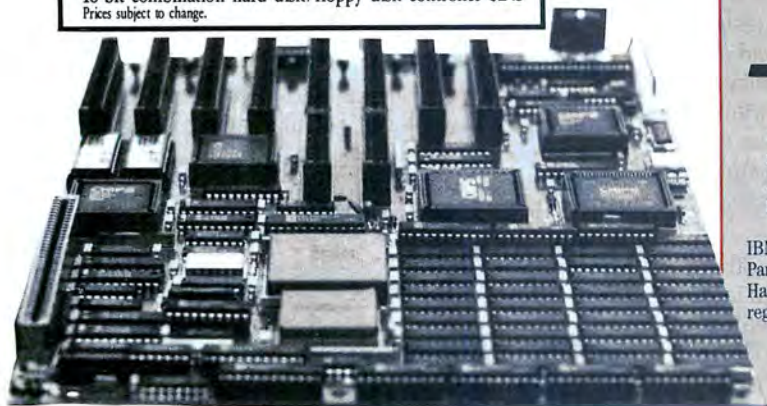

30 DAY TRIAL OFFER AND OUR NO-RISK GUARANTEE

We understand perfectly that you have no reason to believe anything you read. Including this ad. (We read too.)

So we invite you to evaluate the Renegade 386™ yourself. Call and order one. We'll send it with detailed, clear instructions. Use it in your own system, on your own work, for 30 days. Try it for brilliant presentation graphics, make massive and instant spreadsheet recalculation, run huge memory-hungry CAD programs. Wring it out—on anything your software is up to.

But don't stop there. Challenge your best computer technician. Or a consultant whose opinion you value. Ask them to compare Renegade 386™ dollar for dollar, and feature for feature, with the best on the market.

After 30 days, if it isn't for you, for any reason, we'll take it back and write you a check immediately for your full purchase price.

The risk is all ours. But we urge you not to wait. RAM chip prices are going up every day due to worldwide chip shortages. We can guarantee this current price only if you order now.

Call toll-free today. You have nothing to lose but yesterday's computer system.

1-800-426-2189

Renegade

TECHNOLOGIES

Redmond, Washington USA

(206) 885-5700

IBM PC, AT, XT, Personal System/2, Microsoft Windows 386, Foxbase 386, Paradox 386, PageMaker, 1-2-3, Novell Network, Ventura Publisher, EGA, Intel, Hauppauge, Compaq and other brands and products are trademarks or registered trademarks of their respective holders.

New Prices

OS/2

WINDOWS FOR DATA®

MULTI-LEVEL MENU SYSTEM

NESTED POP-UP FORMS

SCROLLABLE REGION

CHOICE LIST

Invoices: Create Review Print Exit

INVOICE

Invoice No.: 008784 Date: 12/83/87 Time: 16:43:15

Customer: William Jones
Innovative Software
351 Bulletin Avenue
Needham, MA 02194
(617) 394-5512

No.	PRODUCT	DESCRIPTION	QUANTITY	PRICE	AMOUNT
5	WDMS	Windows for Data Microsoft	10	295.00	2950.00
6	WDLA	Windows for Data Lattice	5	295.00	1475.00
7	WDTC	Windows for Data Turbo C	5	295.00	1475.00
8	WDXE	Windows for Data XENIX	2	795.00	1590.00
9			0	0.00	0.00
Subtotal:					11325.00
Shipping:					0.00
TOTAL:					11325.00
Payment:					0.00

Cursor keys scroll, ENTER selects and ESC exits choice menu

CLOCK

POP-UP WINDOW

RUNNING TOTALS

MESSAGE WINDOW

If you program in C, take a few moments to learn how Windows for Data can help you build a state-of-the-art user interface.

- ✓ Create and manage menus, data-entry forms, context-sensitive help, and text displays — all within windows.
- ✓ Develop window-based OS/2 programs right now, without the headaches of learning OS/2 screen management. Run the same source code in PC DOS and OS/2 protected mode.
- ✓ Build a better front end for any DBMS that has a C-language interface (most popular ones do).



FROM END TO BEGINNING

Windows for Data begins where other screen packages end, with special features like nested pop-up forms and menus, field entry from lists of choices, scrollable regions for the entry of variable numbers of line items, and an exclusive built-in debugging system.

NO WALLS

If you've been frustrated by the limitations of other screen utilities, don't be discouraged. You won't run into walls with Windows for Data. Our customers repeatedly tell us how they've used our system in ways we never imagined — but which we anticipated by designing Windows for Data for unprecedented adaptability. You will be amazed at what you can do with Windows for Data.

YOU ARE ALWAYS IN CHARGE

Control functions that you write and attach to fields and/or keys can read, compare, validate, and change the data values in all fields of the form. Upon entry or exit from any field, control functions can call up subsidiary forms and menus, change the active field, exit or abort the form, perform almost any task you can imagine.



OUR WINDOWS WILL OPEN DOORS

Our windows will open doors to new markets for your software. High-performance, source-code-compatible versions of Windows for Data are now available for PC DOS, OS/2, XENIX, UNIX, and VMS. PC DOS

versions are fully compatible with Microsoft Windows. **No royalties.**

MONEY BACK GUARANTEE

You owe it to yourself and your programs to try Windows for Data. If not satisfied, you can return it for a full refund.

Prices: PC DOS \$295, Source \$295. OS/2 \$395. XENIX \$1295. UNIX, VMS, please call.

Call: (802) 848-7731

Telex: 510-601-4160 VC SOFT

ext. 51

FAX 802-848-3502



Vermont Creative Software

21 Elm Ave.
Richford,
VT 05476

MICROBYTES

Staff-written highlights of developments in technology and the microcomputer industry, compiled from *Microbytes Daily* and *BYTEweek* reports

Mead's Silicon Retina Points Toward Brain-Like Processing

Carver Mead and associates have developed what could be a true innovation in computer technology: analog emulation of the human nervous system. Mead, who is credited with major contributions to IC design and very-large-scale-integration (VLSI) technology, said construction in silicon of an information processing system similar to the brain is well under way.

Mead and his collaborators at Synaptics (San Jose, CA) have designed a model of a "small but identifiable process of the human brain"; they call it the Silicon Retina. The Silicon Retina consists of a 3- by 4-inch board of analog circuitry connected to a camera lens; it performs the same visual processing as the human retina. The main chip on the board is manufactured by Synaptics and consists of an array of photo sensors that emulate the photo receptors of the human eye. An external object passed across the lens is processed by the analog array processor, and the image is displayed on a standard Multi-Sync video monitor. In a demonstration at San Fran-

cisco's Exploratorium science museum, the image processor was able to accurately display images of the human hand and other objects passed across the lens.

The basic function of animal vision is accomplished by photo receptors that compute the average of the local light intensity and compare this value to the value of the incoming light intensity from the external source. The differential of these values is sent as a signal to the optical nerve, resulting in identification of the external object. The array-processing chip in the Silicon Retina performs a similar function. Mead said that the Silicon Retina represents a "gain control mechanism" for the processing of light signals. It uses a concept called *edge enhancement* to determine the difference in light intensity of the edges of an object in comparison to a uniform background lighting.

Although the Silicon Retina is an impressive example of the power of analog processing, there are still major obstacles to the design of commercially viable systems. According to Mead, analog

processing can achieve "100,000 times the efficiency of digital computing" but is constrained by the lack of uniformity in present-day transistors. Mead said that the human brain is faced with the same problem but gets around it by adapting or adjusting to the inconsistency of the nervous system. This adaptation is accomplished by "averaging" the values of incoming signals. Accomplishing equivalent adaptation in silicon is obviously a major challenge.

Still, Mead predicted that neural technology will eventually have as significant an impact on human culture as the present-day digital computer. Mead donated a working model of his Silicon Retina to the museum.

According to an engineer at Synaptics, the company hopes to have a commercial version of the Silicon Retina ready in about a year. Said Synaptics engineer Tim Allen, "We've proven that it [the Silicon Retina] works in principle. Now we have to make it fast and cheap." Allen thinks the hard part is over. The next phase just requires some basic "semiconductor engineering."

NANOBYTES

- Keep an eye out for **embedded processors** from **Intel** and **Advanced Micro Devices** the next time you buy a new toaster or a new car. Asked why Intel's 80960 is targeted only at embedded applications, Intel chip designer Steve McGeady said, "I'd rather put an 80960 in every antiskid braking system than in every Sun workstation." AMD's Mike Johnson said that although the AMD 29000 would be perfectly suitable for the general-purpose Unix market, there's "simply not enough potential volume, despite all the excitement." Johnson conceded that AMD can't compete in the general-purpose processor market, but he also noted that embedded processors constitute a "billion-dollar market."

- At the Microprocessors '89 symposium, Motorola's Mitch Alsup delivered one of the more refreshing comments on **multiprocessing architectures**. "No one is quite sure how it's going to work," he said. University of Michigan professor Yale Patt pointed out that a big unanswered question involves getting "a large number of processors working in shared memory." The feeling at the conference was that multiprocessing architectures probably won't hit the market until the mid-1990s.

- Sun Microsystems' *continued*

Flexible Superconductors Will Shape PC Boards, Power Supplies

Ever since the 1986 discovery of ceramic superconductors, promises of their potential have flown faster than greased electrons. The media has brimmed over with stories of superfast computers and magnetic-levitation trains, even while scientists have cautioned that such applica-

tions are many years away. But now researchers at MIT have overcome a major impediment to the commercialization of superconductors—their inherent brittleness.

By mixing noble metals, such as silver, gold, platinum, or palladium, into the ceramic material, research-

ers have for the first time been able to create flexible superconductors that can be pressed into sheets or rolled into coils. "Without modification, the mechanical properties of superconductors render them about as flexible as dry spaghetti," said Gregory J. Yurek, an

continued

NANOBYTES

Dave Ditzel proclaimed Sun's SPARC processor as the de facto standard for reduced-instruction-set-computer (RISC) processors, and chip-designer-turned-industry-critic Nick Tredennick countered that Intel would produce more 80386s between coffee break and lunch than Sun would make SPARC processors in an entire year.

- The only legal Macintosh clone available in the U.S. is an Atari ST that uses Mac ROMs. Previously, these ST-based clones have been limited to 64K-byte ROMs; a new version, called the Spectre 128, uses 128K-byte ROMs and is said to run anything that will run on the Mac II (monochrome only) and virtually all Mac Plus and SE software, including the usual suspects: HyperCard, Adobe Illustrator, and PageMaker. Spectre 128 retails for \$179.95, and it comes from Gadgets by Small (Littleton, CO), without the Mac ROMs (you have to get those from other sources). Gadgets by Small is the new company of David Small, who developed the famous Magic Sac Macintosh emulator.

- Despite ongoing—well, rampant—speculation about a new laptop from Apple Computer, Apple's John Sculley says the company's plans for a laptop are still hampered by inadequate screen technology. "I wish we had it now," Sculley said recently, but he added that a laptop is not a big part of Apple's plans for 1989. Sculley said the main

continued

MIT professor and founder of American Superconductor Corp. (Cambridge, MA), which has been set up by the MIT scientists to handle commercial aspects of the new material. "A composite material obviously sacrifices some conductivity, but in exchange you can actually use the superconductors for something useful." In addition, he said, the composite material is more resistant to oxidation and can be connected more easily than before to electrical sources.

The applications for the more malleable material are

still at least 5 years off, Yurek said, but they may include tiny motors, satellite sensing devices, electromagnetic shields for computer power supplies, and printed circuit boards. "Superconductors form a better shield against electromagnetic radiation, all the way from low-frequency DC up to very high frequencies," he said. Flexible superconductors could be shaped into interconnects or traces on printed circuit boards that would be faster and lose less power than current designs. Yurek envisions active components, such as

chips, made with superconductors.

Yurek anticipates no big problems introducing such supercooled fluids as liquid nitrogen into computers, which would be necessary to bring the ceramics down to the -300° Fahrenheit they need to conduct. "Some supercomputers are already cooled by liquid nitrogen," he said. "Now the trick is to get that capability onto the desktop."

"There's no question this development could have quite an impact on computing," Yurek said, "but it's a long way down the road."

BASIC Will Be the "Embedded Language" of Microsoft Applications

Microsoft has "learned its lesson from its Mac experience" and wants to provide a development environment that mimics the delivery environment, says Greg Lobdell, the company's product manager for languages. Therefore, the shell for any future object-oriented programming (OOP) development systems is likely to be Presentation Manager. Inside that shell, the 18 or so OOP building blocks will call routines written in BASIC—not C.

Why BASIC? Current versions are very fast, says Lobdell, and applications built out of OOP tools are likely to be heavily oriented toward transaction processing. BASIC's string-handling capabilities will be an advantage in mixed text-and-integer applications, claims Lobdell. Moreover, BASIC is more "natural," or English-like, than C or Pascal, he says. "BASIC will evolve to be the embedded language of Microsoft's applications."

Ideally, any OOP language products would, like other Microsoft language products, have "inter-language support"—that is, any language could call routines from any other language to ensure a rich application development environment. In the long term, Microsoft wants to provide a set of object-oriented building blocks, the functional equivalent of NeXTStep's 18 basic OOP routines to handle dialog boxes, menus, and so on.

CISC or RISC, Chips Are Becoming More Alike

Bring together some of the designers who worked on the computer industry's major microprocessors, and chances are they'll each have a different opinion about which microprocessor is the best. At a recent conference sponsored by the *Microprocessor Report* newsletter, we heard proponents of Intel, Motorola, Sun, Advanced Micro Devices, and MIPS Computer extol their favorite chips and architectures. But one thing they all seemed to agree on

is that microprocessors are in some ways becoming more and more alike.

"CISC processors are becoming more RISC-like, and RISC processors are becoming more CISC-like," said Motorola's Russell Stanphill. In the next few years, implementations of complex-instruction-set-computer chips and reduced-instruction-set-computer chips will become much more similar, predicted Michael Slater, who edits the *Microprocessor Report* and orga-

nized the conference.

The designers generally agreed that within the next few years, all the major microprocessors will have cache, floating-point, and memory management units built in, and they'll incorporate features like register scoreboarding and separate data and instruction paths.

But the chip designers said they're concerned about the limitations of performance that confront single-processor architectures. In

continued

To learn Microsoft QuickBASIC, you only need a manual this thick.



You're looking at something you won't see anywhere else.

It's called QB Advisor. A remarkable new hypertext electronic manual that can make you instantly more productive, even if you don't know the first thing about programming. QB Advisor actually lets you experiment by cutting and pasting useful sample programs right into your programming window. Only Microsoft has it. Only Microsoft could. And it's just one of the things you'll learn about new Microsoft® QuickBASIC version 4.5 for IBM® PCs and compatibles.

Another is the step-by-step tutorial that actually takes you through every stage of programming by working you through a complete program.

And QB Express—the interactive way to learn all about your programming environment in a matter of minutes—not hours.

Microsoft QuickBASIC also comes with Easy Menus that let you develop programs with

a minimum number of menu choices. Context-sensitive Help for immediate help with error messages and variables by simply punching a key, or clicking a mouse. And a built-in debugger that lets you see exactly what your program is doing, as it's doing it.

Best of all, Microsoft QuickBASIC is packed with enough power to handle whatever problems drove you to programming in the first place. Fact is, it translates your program into executable code at an incredible 150,000 lines per minute.

Microsoft QuickBASIC version 4.5. If programming is the only way out, this is the easiest way in.



Microsoft®
Making it all make sense.™

NANOBYTES

problem with current laptop displays is that they can't handle mouse operations adequately. According to Sculley, the mouse pointer "disappears" when you drag it quickly across the screen. Sculley said he "hopes to see a laptop in 1989, though not in quantity." Apple is looking at active matrix displays as one possibility, we hear.

- For those who missed the news, the U.S. now has an official **undersecretary for technology**. It's a new position in the Commerce Department, responsible for the department's new Technology Administration. "The undersecretary for technology will serve as a strategic catalyst to promote the use of science and technology by industry and entrepreneurs," said an official statement from Washington.

- The industry will be able to use the help, if things shape up the way the **American Electronics Association** predicted in a recent release. If the U.S. doesn't play a strong role in the **high-definition TV (HDTV) market**, there'll be a "ripple effect" that will cause the country to lose "significant" world market share in personal computers and semiconductors. The report warns that the country's current 70 percent share of the world personal computer market could dwindle by the year 2010 to half that if the nation's electronics companies don't take the lead in HDTV.

- Citing "misrepresentation of facts surrounding the issue of com-

continued

spite of Dave Ditzel's glowing prediction that Sun will be the first company to offer a RISC chip with 4-nanosecond cycle times, the big question is how to supply memory subsystems that are fast enough for these high-speed processors. As Intel's Steve McGeary put it, "Talking about 4-ns cycle time is fun, but who's going to sell you memory for that?" Motorola's Mitch

Alsup agreed that the biggest challenge is designing memory and processor I/O that can keep up with cycle times of less than 10 ns.

Professor Yale Patt of the University of Michigan said object-oriented data models may be part of the answer to increasing memory bandwidth. He also argued that simply adding bigger caches and multilevel caches is not the answer. Addition-

al caches become slow and complex, Patt said. He outlined a new model for microprocessor design that introduces new concepts for instruction control and data execution, including "wide words" and node tables for storing and predicting the instruction stream. Patt described the concept as "pipelining with rest areas. You're only on the highway when you're working."

Computers, Communications Play Role in New Global Foundation

Computers and electronic communications will play a fundamental part in the new International Foundation for the Survival and Development of Humanity, an ominously named group of scholars and scientists addressing such ominous global problems as environmental pollution, nuclear disarmament, and abuses of human rights. The foundation has an impressive list of members, including Soviet physicist Andrei Sakharov and the former President of MIT, Jerome Wiesner.

At a press conference sponsored by Apple Computer, members of the foundation discussed electronic conferencing and communications as a means of improving relations between the U.S. and the USSR. (Apple has donated computers to the group, and Apple CEO

John Sculley is on its board of directors.)

The foundation, which has offices in Moscow, Stockholm, and Washington, DC, is raising money and accepting project proposals. One project proposed already is an electronic communications system between the U.S. Congress and the Supreme Soviet, the primary legislative body in the USSR. Another project involves the expansion of a U.S.-Soviet computer training camp for children.

With members from all over the world, the foundation will use an electronic conferencing system to conduct its activities. Computers will also be used for projects involving the collection of environmental data relating to acid rain, the "greenhouse effect," and other forms of pollution.

Sakharov expressed frustration at the group's slow progress thus far. Speaking at Apple's press conference via satellite, Sakharov said he has a "cautious attitude" toward the foundation; it has been "mainly talk" so far, he said. Wiesner, though, responded that now that the foundation has been officially sanctioned in the USSR, it will start to aggressively solicit projects.

The foundation hopes to sponsor about 10 projects per year. It encourages project proposals that involve international cooperation, particularly between the U.S. and the USSR. For information on submitting project proposals or contributions, you can write to the International Foundation for the Survival and Development of Humanity at 109 11th St. SE, Washington, DC 20003.

NMB's 1-megabit DRAM Chip Claims Top Speed

NMB Technologies (Chatsworth, CA) says it has developed the "world's first" 60-nanosecond 1-megabit dynamic RAM chip. Although other manufacturers are soon to follow, NMB's AAA1M200 is the first formally announced 1-megabit DRAM with a minimum access time of 60 ns. Currently avail-

able 1-megabit DRAMs have access times ranging from 80 ns to 125 ns.

The new DRAMs are targeted for high-performance 32-bit processors operating at 16 MHz or higher. Most 32-bit machines operating at 20 MHz or higher require at least one wait state to compensate for the speed of currently available

DRAMs. The 60-ns DRAM will allow manufacturers to eliminate wait states and also complex memory interleaving and caching schemes, an NMB spokesperson claimed.

The company said it will start shipping the high-speed DRAMs in volume in the second quarter of this year. It

continued

You'll never know how quick it is until you open it up and see what it can do.

All the horsepower in the world is useless until you can get at it.

Introducing new Microsoft® QuickC® version 2.0. The fastest, easiest way to master all the power and glory of C. Frankly nobody but Microsoft packs this many exclusive features into a single package:

For starters, there's QC Advisor—a new hypertext electronic manual that teaches, helps and guides you *on screen*. It even lets you cut and paste sample programs, so you can learn C the easy way.

By example.

And "C For Yourself," our detailed book of C fundamentals that'll give you more in-depth programming lessons. You'll find one in every box.

With Microsoft QuickC, you can ease into C with Easy Menus to help you write your first C programs, then advance to Full Menus to access the full-throttle potential of C. You'll be up to speed in no time.

And speaking of speed, QuickC has enough muscle for incremental compiling and linking at an incredible 25,000 lines per minute—so it'll make short work of any development you have in mind.



New Microsoft QuickC 2.0. Zero to expert in record time.

And speaking of development, its in-line assembler lets you write assembly code within your C code for more efficient programs. Plus it's the only integrated debugger that lets you simultaneously debug C *and* your in-line assembler. Talk about convenience. It even supports all memory models within the integrated environment.

For all the details, call us at (800) 541-1261. The new Microsoft QuickC.

Get it. And break a few speed limits.

Microsoft®
Making it all make sense.

NANOBYTES

puter viruses," The **Software Publishers Association** has formed a special-interest group to deal with the **security issues** raised by electronic diseases. The SIG hopes to serve as an "objective forum" for exchanging information relating to viruses, Time Bombs, Trojan Horses, worms, and vaccines. If interested, phone the Software Security SIG at (202) 452-1600.

• Although **American Megatrends** (Atlanta, GA) says its new 80386 motherboard is designed for **33-MHz components**, the unit we saw recently has a 25-MHz 80386 inside running at 33 MHz. The system

continued

could mean the start of fierce competition among DRAM manufacturers to offer higher-speed memory chips, which will be needed

to keep up with the ever-faster processors in ever-faster workstations. NMB Technologies is an American arm of the Japanese elec-

tronics manufacturer Minebea Co. of Tokyo. Minebea also makes keyboards, power supplies, and miniature precision bearings.

Optical Drives Could Boost Entertainment Software

After losing shelf space at software retail stores and failing to attract a bigger base of users, producers of entertainment software are hoping that optical drives will result in dazzling programs and hence increased interest in games and other nonbusiness (i.e., fun) programs. The customer base so far has consisted mainly of men and boys between 12 and 45. Several hundred companies used to make computer games, but many have gone out of business or seen sales decline.

Some of the survivors of

the entertainment software business were on a panel at a conference in San Francisco recently, including Electronic Arts, EPYX, Mediagenic (formerly Activision), and Spectrum Holobyte. The main theme of their discussion was that today's personal computers are too primitive to run the kinds of games that would attract a broad consumer base for entertainment software. Trip Hawkins of Electronic Arts pointed out that the most popular games machine these days is a cheap IBM PC clone, which has replaced the

Commodore 64 as the home computer of choice. But the bare-bones PC clone with CGA-resolution monitor isn't "friendly enough" for the mass market. Hawkins said that the entertainment market is still a market for "hobbyists."

The big hope for the entertainment software business is the proliferation of optical drives and media, such as CD-ROM and similar technologies. CD-ROM will allow entertainment software developers to put megabytes of data on a sin-

continued



Protect the one you love.

Yours is not just any computer. It's your friend. Your confidant. Your business partner. You wouldn't be without it.

But it can happen in a flash. A sudden storm, distant ditch digger, motor, or even a toy metallic balloon can send data-killing, component-killing electric surges and sags smack into your computer. Even knock it out altogether.

It's a matter of time before this happens to you. So protect your friend with Emerson's

new low-cost SW1000 Uninterruptible Power System. Only 2¼ in. high, it fits smartly right under your PC's monitor for less than \$700.

In a brownout or blackout, a battery will instantly take over giving you ten minutes or more to shut down your computer.

Call 1-800-Back-UPS for the Emerson dealer nearest you. Before it's too late.

EMERSON
Computer Power
Computers Won't Run Right
On The Wrong Fuel.

BRIDGES



The *easy* way to move files between the 5 1/4" world of PCs, and the 3 1/2" world of PS/2s, Laptops, and 386s: Sysgen's Bridge family.

Because your PCs, PS/2s, 386s and laptops all talk to different floppy disk sizes and formats, they can become frustrating *islands* of information.

For the simplest way to get files back and forth, just install Sysgen's Bridge products. Presto: Your different computers can talk to common diskettes.

Sysgen pioneered bridges. Now here are three ways to simplify your life in a multi-computer office.

Solution 1: Our Bridge-File 5.25 floppy disk drive.



A best seller, with over 50,000 installed. Attach it to your PS/2, and you can read and write files from PCs. Critics and users alike have raved

about its small footprint, ease of use, and dual density capacity of 360Kb and 1.2Mb. (IBM's drive is twice the size, yet stores only one-fourth the data.)

Every PS/2 user deserves this easy connection to the world of PCs.

Solution 2: Our Bridge-File 3.5 floppy disk drive.

You get 720Kb and 1.44Mb capacities. Connect it to any PC, and you can read and write files from PS/2s, 386s, laptops, and other 3 1/2" machines.

Now all your PCs can share files with your newer systems.



And here's the ideal controller: The Omni-Bridge Controller.



Controls up to four drives, so you can mix and match 5 1/4", 3 1/2", and floppy tape drives as you need. This hot card gives you big storage, plus twice the floppy disk and floppy tape transfer performance rates! At only \$95, this is a winner.

Get your computers talking. Call the Sysgen Hotline for the name of your nearest dealer. 1-800-821-2151.

SYSGEN

INCORPORATED

556 Gibraltar Drive, Milpitas, CA 95035

FEBRUARY 1989 • BYTE 17

Trademarks: Sysgen, Bridge-File, Omni-Bridge—Sysgen Inc.; PS/2—International Business Machines Corporation. Registered Trademark: IBM—International Business Machines Corporation.

Circle 226 on Reader Service Card

NANOBYTES

has support for 8 megabytes of 60-nanosecond dynamic RAM on the motherboard, and a 32-bit expansion slot for up to 8 megabytes more. The product's designers went with 4 megabytes of single in-line memory modules and 4 megabytes of standard DIP memory because they weren't sure which would be most hit by a shortage. AMI officials said they weren't sure when they'll be able to get Intel-certified 33-MHz 80386s.

- Some optical storage companies have banded to back the **Continuous Composite Servo (CCS)** recording format for 5¼-inch erasable optical

continued

gle disk and thus create more complex and dynamic games. But you need faster performance than current CD-ROM technology provides to make games per-

form well. Optical storage in the 1990s could provide the breakthrough needed for entertainment software to take off again. In the meantime, the survivors are

faced with a resurgence of competition from Japan and Europe. As Hawkins said, "there's an increase in product supply without an increase in demand."

Even on a Cloudy Day, Norton Can See DOS Forever

While forecasts call for increased use of Unix and OS/2, in the future according to Peter Norton, MS-DOS "goes on forever." Norton, of self-named Utilities fame, said in an interview with *BYTEweek* that he foresees the hordes of PC users eventually falling into three camps—"OS/2, High-DOS, and Low-DOS." Norton equated High-DOS users with today's "power users." There will be a huge market of "Low-DOS" users, he said, with 80286-based machines becoming

the low-end standard.

And what does the company president/writer/industry celebrity think of OS/2? It's "a necessary evil," Norton said, "because it's both necessary and evil." He sees OS/2 being accepted mainly by "MIS types" in large corporations who want multitasking functions, "Unix-like features without throwing away DOS." Norton sees "nifty stuff" coming eventually for the OS/2 environment. The RAM shortage put OS/2 back "2 to 3 years"; other-

wise, many users would have installed 2 to 4 megabytes of RAM by now and would have had the opportunity to "play" with memory-hungry OS/2, he said. As it stands now, "only the damn serious can afford to run OS/2, and the payoff isn't there yet."

Norton predicted that many of those "nifty" OS/2 applications will get "converted and crammed back into the MS-DOS environment," although he added that those conversions will be a "painful process."

continued

Travel With A Fast Crowd.



Wherever your business takes you, take along the WorldPort 2400™ Portable Modem. Leaving the office doesn't have to mean leaving behind the world of high-speed, 2400 bps communications. Worldwide, in virtually every situation, including hotel rooms and phone booths, your ability to communicate clearly and efficiently remains intact.

Representing the cutting edge of modem technology, the WorldPort line of portable modems combine a broad range of features that bring you the best value in modems today. Features

that go far beyond costly internal units, such as Bell and CCITT standards, direct connect and acoustic interface (300 and 1200 bps), battery power, shirt pocket size, and a tiny price.

In fact, the WorldPort modems are the ultimate for both portable and desktop applications. And the WorldPort 2400 comes with Carbon Copy PLUS™ communications software, for even greater value.

If you want a modem that works where you do, put the WorldPort Series to work for you. In

the office. On the road. Or at home. For more information about our full line of WorldPort modems, or the name of your nearest dealer, call us at 800-541-0345. (In New York, 516-261-0423.)



Touchbase Systems, Inc.
160 Laurel Avenue
Northport, NY 11768
(516) 261-0423
TELEX: 6502848020
FAX: (516) 754-3491

WorldPort 2400 is a trademark of Touchbase Systems, Inc. Carbon Copy PLUS is a trademark of Meridian Technology, Inc.

THE BUS STOPS HERE!

CompuStar: PS/2 and PC/AT Compatibility.

Ask any computer expert about what type of system you should buy nowadays and you'll likely get a "pass the bus" response. Something like — "Well, uh, the PC/AT* bus is your best buy but, then again, the new PS/2* bus may become the next industry standard." Great advice, right? If trying to decide on a microprocessor weren't tough enough, now you're expected to pick a bus, too.

RELAX, NOW THERE'S COMPUSTAR®

The all new CompuStar from Wells American not only lets you interchange microprocessors, you can also mix and match buses — a PC/AT bus, a PS/2 bus or... both. As your computing needs change, simply snap in a new processor or add an extra bus. You'll never again have to worry about buying the *wrong* computer system!

FOUR COMPLETE SYSTEMS IN ONE.

The CompuStar can be configured with any of four microprocessors — an 8086, an 80286, an 80386SX, or an 80386. The processor and up to 16 megabytes of user memory have all been combined, using the latest VLSI technology, on a single, plug-in CPU module. Plus, any time during the first year of ownership, CompuStar users can "trade-in" the CPU module they initially selected toward the purchase of any of the other more powerful modules. *Nobody* but Wells American gives you this kind of value.

A CONVERTIBLE BUS? YOU'RE KIDDING!

No, we're not. In fact, it may well be the most practical microcomputer innovation ever. Say you've selected an AT compatible CompuStar and later want to add PS/2 compatibility. No problem! Snap in a PS/2 Bus and Adapter Module and you can use *both* buses in the same system. Likewise, if you've selected a PS/2 compatible CompuStar and decide you want to add an AT bus, just snap in an AT Bus Module. Depending on configuration, the CompuStar can have up to 13 bus expansion slots — all AT slots, all PS/2 slots or a "split-bus" of AT and PS/2 slots. No matter which bus becomes the

next industry "standard," you'll have peace of mind knowing your investment in a CompuStar will be protected.



The CompuStar is also easily expanded. That's because there are seven CompuStar disk/tape compartments — six accessible from the front and an additional full-height bay inside. All this in a sleek, compact tower design that will leave *more* room on your desktop than any of the so-called "desktop" models.

A NEW IDEA FROM AN OLD COMPANY.

The CompuStar® Multi-Processor, Convertible Bus™ Microcomputer. It's no surprise that our engineers invented it. After all, we've been making microcomputers longer than anyone else... even longer than IBM! And if that kind of experience doesn't impress you, CompuStar's service programs surely will. You can select an optional overnight module swap-out plan or on-site service from General Electric Corporation — one of the most respected names in consumer electronics. And, of course, every CompuStar carries a full one-year factory warranty.

FINALLY, AFFORDABLE TECHNOLOGY.

Think all this technology sounds expensive? It's not. Thanks to CompuStar's modular architecture, you pay only for the technology you need — and *only* when you need it.

Plus, there is a wide variety of CompuStar display, tape and disk options including a one gigabyte erasable optical disk. You can choose a factory pre-configured CompuStar or custom design one yourself. Just unlock the front panel and literally "snap-in" a bus, CPU, memory or disk module in a matter of seconds. It's system flexibility never before available... at any price.



While one of our competitors (we won't mention any names) threatens you with "missing the bus," most simply *pass* the bus. Our new CompuStar, however, *eliminates* the bus problem altogether. Not to mention the processor problem. Even the expansion problem. Prove it to yourself. Call today about our 31-day trial offer. Oh, and by the way, the next time anyone asks, tell 'em you know where the bus stops.



Wells American.

Corporate Headquarters: 3243 Sunset Boulevard
West Columbia, South Carolina 29169 • 803/796-7800
TWX510-601-2645 • FAX 803/796-7029

NANOBYTES

disk cartridges. Supporting CCS, currently before ANSI and ISO for formal endorsement, are Advanced Micro Devices, Hewlett-Packard, Hitachi, Maxtor, Mitsubishi, Olympus Optical, Optotech, Scientific Micro Systems, and Western Digital.

- In a joint deal between **Borland International** and **Digital Research, Inc.** (Monterey, CA), OEMs can offer their customers certain Borland programs to go along with DRI's **DR DOS**. Computer makers who use DRI's enhanced DOS in their systems can also throw in Borland's SideKick, Turbo Pascal, Turbo C, and Turbo Basic.

- The world of **three-dimensional spreadsheets** will get a little more crowded this spring when **FormalSoft** (Sandy, UT) starts shipping its new ProCube program. The package's features include slicing across multiple spreadsheets, three-axis presentation graphics, conditional embedded external application calls, and ASCII file macros. The design uses virtual memory to extend large worksheets out onto the disk. The company plans to sell ProCube for \$247.50.

- Remember that this month we celebrate **National Engineers Week** (February 19 to 25). The theme of the week is "Turning Ideas into Reality," and the societies that are sponsoring the idea would like us all to honor the engineer "as innovator and problem solver." Just to clarify things, we're not talking about the ones who drive trains.

Wescon Highlights: Toshiba's Big LCD, Eighteen Eight's Array Processor

It doesn't have the glitz and critical mass of COMDEX, but the IEEE's Wescon electronics exhibition is no small potatoes. This year's show in Anaheim featured some 6000 exhibitors and an estimated attendance of nearly 60,000. If you're shopping for transducers, printed circuit board design software, digital waveform analyzers, and miniature bearings and IC testers, Wescon is the place to be.

Although most of the showcased products are aimed at designers and manufacturers of electronics components, there are always a few new products of importance to end users. For example, Toshiba unwrapped its new 640- by 480-pixel liquid crystal

display for laptop computers. Unlike conventional double-layer displays, the M-ST black-and-white unit uses a single-layer, backlit design. It's only 20 millimeters thick and weighs about 700 grams (about 1.5 pounds). With a .33-mm dot pitch, the M-ST display has excellent contrast and will certainly attract the interest of laptop computer manufacturers. However, the M-ST is not cheap; "sample pricing" is \$646. Toshiba said it is planning to ship the new display in volume this spring.

Another eye-catching product at the show was a floating-point array processor for IBM PCs and compatibles. Eighteen Eight Laboratories claims its PL800

array processor delivers 8 million floating-point instructions per second for a price of \$1995. You can install up to eight PL800 processor boards in a single machine. The PL800 comes with a library of 473 micro-coded functions and supports most popular FORTRAN, C, and Pascal compilers, including those from Microsoft, Borland, Lattice, Lahey, and Ryan-McFarland. The 8-bit board requires only about 5 watts of power.

For more information, contact: Toshiba America, 9775 Toledo Way, Irvine, CA 92718, (714) 455-2000; Eighteen Eight Laboratories, 771 Gage Dr., San Diego, CA 92106, (619) 224-2158.

Simulation System Could Cut Costs of Real-Time Design

Athena Systems (Sunnyvale, CA) has a new computer-aided software engineering (CASE) and simulation tool that could cut down the costs of designing real-time systems. The graphics-based Foresight, which runs on Sun workstations, is a sophisticated simulation program that uses the concepts of block diagrams and data flow to represent physical processes.

While CASE tools supporting Yourdon/DeMarco methods are available, as are both discrete and continuous systems simulators, Foresight combines them.

The program also implements real-time extensions to CASE methodology. The developers claim that Foresight will change embedded systems engineering in much the same way that CAE tools have changed the design of ICs and printed circuit boards.

"Foresight helps uncover errors during the early requirements definition stage—where most design flaws are introduced—before hardware and software engineers proceed with their development tasks," said Patrick Rickard, president of Athena. "It's essen-

tial to correct errors early because the cost to repair them increases exponentially as the project progresses," he added.

Development of embedded real-time systems, which are extremely complex, is notorious for cost overruns and schedule slippage. In the aerospace and defense industries, for example, where embedded systems are used extensively in applications such as aircraft guidance, electronic switching, and weapons control, the reliability of software and hardware in the real world is a very major concern.

Foresight, by personal computer standards, is not cheap by any means; it costs \$23,680 per user for a 10-user license.

For more information, contact: Athena Systems, 139 Kifer Court, Suite 200, Sunnyvale, CA 94088, (408) 730-2100.

TECHNOLOGY NEWS WANTED. *The news staff at BYTE is interested in hearing about new technological and scientific developments that might have an impact on microcomputers and the people who use them. If you know of advances or projects relevant to microcomputing, please contact the Microbytes staff at (603) 924-9281, send mail on BIX to Microbytes, or write to us at One Phoenix Mill Lane, Peterborough, NH 03458. An electronic version of Microbytes, which offers a wider variety of computer-related news on a daily basis, is available on BIX.*



Everything it takes to add PostScript to your LaserJet II, including HP's blessing.

Hewlett-Packard* and QMS* have made it easy to give your LaserJet Series II* the desktop publishing power of the PostScript* page description language.

The new QMS JetScript™

JetScript is the only Adobe PostScript controller upgrade authorized by HP and designed specifically for the LaserJet Series II. JetScript gives your printer the industry-standard page description language to accompany HP's PCL printer language. This expands your laser printing capabilities. Increases overall printer performance. Yet preserves HP functionality and warranties.

Do it yourself JetScript is easy to install. Just plug in two cards (one in your personal computer*, the other in your printer), connect a cable and install the software.

The result is a PostScript system with 35 resident Adobe typefaces, three megabytes of RAM, and QMS ASAP™ (Advanced System Architecture for PostScript) proprietary technology for superior performance. All for less than half the cost of a new PostScript laser printer.

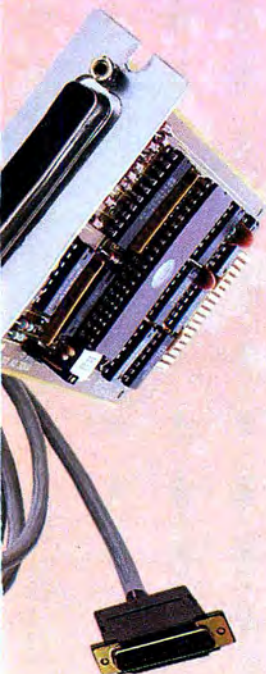

New forms of expression The speed and power of JetScript combine to give your LaserJet Series II a form of expression that's found only with PostScript.

Simply, PostScript opens up the full range of possibilities for desktop publishing. You have complete control over the final look of the page, down to the last exacting detail. PostScript allows for an infinite number of font variations and sizes. That makes PostScript's limitless flexibility and power the perfect complement to your LaserJet Series II, giving you the high-quality output you require.

Impressive results People have come to expect impressive results from QMS—one of the first companies to bring the power of PostScript to laser printing, and now with more PostScript-based products than any other company.

You'll get the same results from the new JetScript. After all, it has HP's blessing.

Laser Connection is a sales and marketing subsidiary of QMS. Call **1-800-523-2696** for the location of your nearest Laser Connection dealer.

**JetScript available for IBM PC-XT*, IBM PC-AT*, HP Vectra™ and compatible personal computers, or the IBM PS/2™ Model 30.*



A QMS* Company

Circle 127 on Reader Service Card

The following are trademarks of their respective companies: HP, Hewlett-Packard, LaserJet Series II, HP Vectra of Hewlett-Packard, QMS, JetScript, ASAP, Laser Connection of QMS, Inc. PostScript of Adobe Systems. IBM PC-XT, IBM PC-AT and IBM PS/2 of International Business Machines Corp.



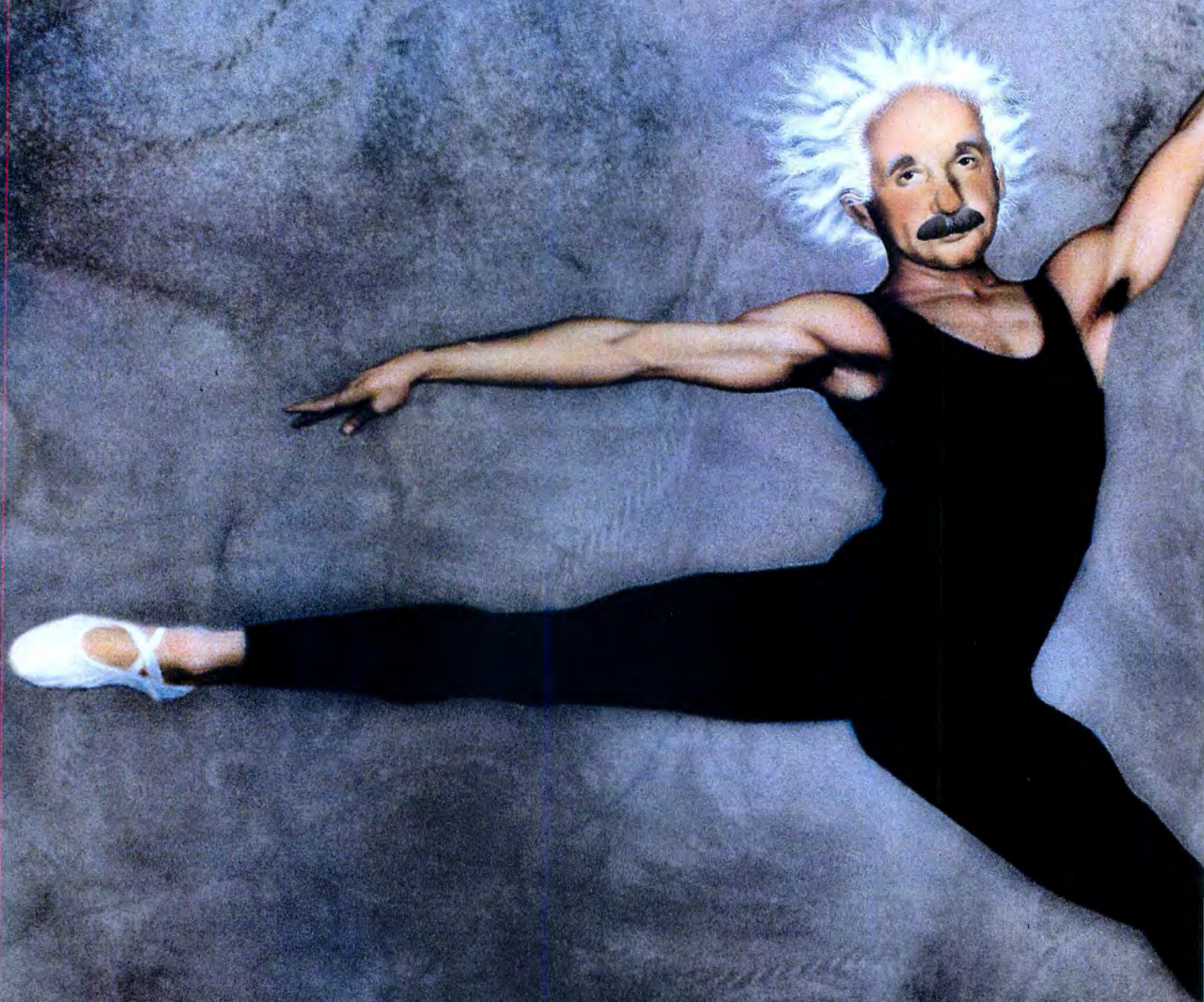



Announcing a big leap in mouse technology.

Finally, a mouse with an extraordinary body and a mind to match.

A mouse ballistically tuned to accelerate your cursor across any screen with the mere flick of a wrist, and slow it down on arrival for pixel-point control on detail work.

This mouse is guaranteed to work with all applications on your IBM personal computer. And it comes with a great selection of MouseWare™ including Pop-Up DOS™—the ultimate DOS handler; Mouse-2-3™, the Lotus 1-2-3™ shell; and 35 menus for best-selling keyboard-based applications.

The Logitech Mouse. \$139, complete with Logitech's Lifetime Satisfaction Guarantee and unlimited Product Support.

For your nearest dealer, call:

800-231-7717

*In California:
800-552-8885*

*In Europe:
++ 41-21-869-96-56*

*Circle 133 on Reader Service Card
(DEALERS: 134)*



OUTSTANDING SOFTWARE

\$2.49

Per Disk
(\$2.99 per disk
when ordering
less than 10)



Satisfaction Guaranteed or Money Back!

BUSINESS

- 13 **Express Calc** - (2 disks) Powerful financial spreadsheet.
- 53 **EZ-Forms** - Create, fill in, print yr business forms. 512K.
- 79 **Invoicer** - Generate invoices, ease record keeping.
- 117 **Finance Mgr II** - (2 disks) Handle personal/bus finances.
- 135 **PC-Acct** - (2 disks) Manage books, track inventory, sales.
- 159 **Mass Appeal** - Mail mgr for envelopes, labels and more.
- 190 **PDS*Quote** - Compute job/cost estimates. 640K.
- 201 **Checks** - Log bank transactions, produce financial rpts.
- 226 **File Express** - (2 disks) Menu driven all purp database.
- 232 **Dr Data** - (2 disks) Friendly, easy-to-use mail mgr. 640K.
- 234 **T-Master** - Control & update inventory. Know daily levels.
- 316 **Tracker** - Manage clients, sales prospects! 512K, hrd disk.
- 319 **EZ-Desk** - (2 disks) Keep appointments, update agendas.
- 337 **Charge** - Analyze your credit charges, payments, interest.
- 383 **Mutual Fund Mgr** - Track yr portfolio, get weekly reports.

EDUCATION

- 186 **DOS Tutor** - Learn DOS painlessly w/this interactive tutor!
- 191 **PC-Quizzer** - Learn music, States, etc. Sign lang demo.
- 228 **PC-Fastype** - Teaches typing. Builds dazzling speed! ★
- 297 **XY-Solve** - Graphic math game makes learning fun!
- 366 **Gradescan** - Makes it simple to keep and avg grades.
- 376 **GradeM** - Teachers/students can track/summarize grades.
- 384 **XY-See** - (2 disks) Graphic math for HS/college students.

GRAPHICS

- 58 **Chemview** - Rotating 3-D molecular structures. EGA.
- 145 **Fingerpaint** - (2 disks) Paint! Also obj oriented dsgn. ★
- 210 **Dancad3D** - (2 disks) Advanced design. 640K/hrd disk. ★
- 285 **Surfmodl** - (3 disks) Produce & shade 3-D images. ★
- 356 **Geoclock** - (2 disks) Time map w/sun, dark areas! EGA.
- 362 **VGA Cad** - (2 disks) Super res 256 color painting! VGA.

GAMES

- 15 **Biblemen** - Exorcise knowledge of Bible figures/events.
- 23 **Star Trek** - Amazing high res! Also Othello, Artillery. EGA.
- 28 **Wordplay** - (lk Wheel of Fortune). Also Backgammon. ★
- 84 **Solitaire** - Grt card games, Spider, Klondike, Canfield! ★
- 121 **Arcade** - Qubert, Pango, Centipede, Hopper & more. ★
- 151 **Hack** - You & yr trusty dog in a wild adventure (lk Rogue).
- 176 **Striker** - Helicopter attack. Also Risk, world domination. ★
- 215 **Phrase Craze** - Solve word puzzles or create your own!
- 289 **3-D Pacman** - Also Kong, Spacewar, ABM (missiles). ★
- 309 **Blackjack** - (you set rules). Also ArmchairQB & Empire!
- 321 **Adventure** - Explore the caves! Also Castle, Star Trek.
- 365 **Adventure Game Toolkit** - (5 disks) Play, create yr own!
- 372 **Pinball** - Also Othello, Dragons, Sowith, Battleship. ★

UTILITIES

- 138 **Printer Utilities** - Spooling, banners, fonts & more!
- 214 **Zip-Phone** - (2 disks) Xrefs phone# to zipcode & vice-vers.
- 258 **Easy Access** - Setup a menu sys for your PC. Hard disk.
- 275 **DOS Utilities** - Large collection of invaluable general utils.

MISCELLANEOUS

- 31 **Movie Database** - (2 disks) Lists 4,000+ films. Grt trivia!
- 48 **Wisdom of the Ages** - (4 disks) 6000+ famous quotes.
- 72 **Bible** - (12 disks) Cmpnt indxd King James bible! Hrd disk.
- 74 **Landlord** - Trouble w/yr landlord? Learn your legal rights!
- 146 **PC-Lotto** - Helps you beat your state's lotto odds!
- 153 **PC-Write** - (2 disks) Popular, powerful word processor.
- 291 **PianoMan** - (2 disks) Record your tunes or play music.
- 367 **Music Library System** - Track your tapes, LPs & CDs.
- 386 **Computer Chef** - (2 disks) 150+ grt recipes. Add yr own!

★ Disks so marked above require a color graphics adapter.

■ **Membership Special! \$19.95 (reg. \$34.95)**

For \$19.95 (\$25.95/year for 3.5") become a MicroCom Systems member and get: **"The Shareware Book"** (\$12.95 separately), a subscription to **"Shareware Review"** magazine, 6 free new-release shareware disks (one featured each issue), low member prices, and any disks in this ad for only \$1.99 each! (\$2.99 for 3.5")

■ **3.5" disks desired (add \$1.00/disk to applicable price)**

MicroCom Systems	Cost of disks _____
3673 Enochs Street	Membership _____
Santa Clara, CA	Shipping \$3.00
95051	CA res tax _____
	Total encl. _____

Phone Toll Free for Same-Day Shipment!

(800) 727-5995
 ©1988, MCS Mon-Fri 7am-9pm, Sat-Sun 8am-5pm BY-02/89

LETTERS

The High Cost of RAM

The unkind words about OS/2 ("OS/2's Multitasking Dashboard" by Mark Minasi, November 1988) are a classic example of blaming the victim.

Microsoft must have had to make its final decision on memory usage a couple of years ago. Back then, the price of RAM was about \$100 per megabyte, with a prospect of further decline by now to, say, \$25 to \$50 per megabyte (the September 1988 BYTE had ads for 150-nanosecond 256K-byte chips at \$2.95 each, or \$106.20 per megabyte). There was an intense ferment over all sorts of ways to use more RAM—RAM disks or Expanded Memory Specification memory (not one, but two competing varieties). On that basis, it must have been almost impossible to justify less than 4 megabytes for any operating system that broke the 640K-byte barrier.

What happened was this: Largely due to protectionism, RAM prices rose to \$400 to \$500 per megabyte. Don't blame Microsoft; blame the politicians. And bear in mind that OS/2 is by no means the only computer product injured by high RAM prices.

Andrew D. Todd
Springfield, OR

Just Don't Get Too Excited

I'm a novice computer user, and BYTE gives me a lot of pleasure.

I'd like to offer a comment on Brock N. Meeks's "Computer Conferencing Homecoming" (September 1988). This is the kind of article that turns my pace-maker on high. Maybe in the future, Mr.

Meeks will be able to keep people like me in mind and write a piece that could help us get started on BIX, MIX, and CompuServe.

Reg. Roberts
Costa Mesa, CA

The Old Spool Tie

I cannot let Jud McCranie's authoritative-sounding correction of Brett Glass's spool definition (Letters, October 1988) stand unchallenged.

In the interest of historical accuracy, spool is indeed an acronym for "simultaneous peripheral operation on-line." Mr. McCranie states that his somewhat literal interpretation of the word *spool* dates back to "the old mainframe days." Just how old is Mr. McCranie, anyway? In the old mainframe days (and now), spooling was usually a high-priority task involving direct-access devices (disks and drums), rather than reels (or spools) of tape. The practice of sending print output to tape, although common, has little to do with the original intent of spooling.

As for the acronym being a "recent ad hoc creation," there is a terrific explanation of spooling in Harry Katzan Jr.'s excellent book *Operating Systems: A Pragmatic Approach*, published in 1973. Professor Katzan observes that "spooling was the first stage of multiprogramming as we know it today."

Joe Riley
Los Angeles, CA

True Meanings

Dennis Lee Bieber misrepresented the true meaning of the names of the P and V semaphore primitives (Letters, October 1988). According to professor E. W. Dijkstra himself, while teaching a course entitled "Operating Systems Techniques," he derived the names P and V from two Dutch verbs, "pakken" (seize) and "vrÿgeven" (release). Even with the coincidental starting letters, "procure" and "vacate" capture the spirit nicely.

Signal and wait functions are typically performed on events for process syn-

continued

WE WANT TO HEAR FROM YOU. Please double-space your letter on one side of the page and include your name and address. We can print listings and tables along with a letter if they are short and legible. Address correspondence to Letters Editor, BYTE, One Phoenix Mill Lane, Peterborough, NH 03458.

Because of space limitations, we reserve the right to edit letters. Generally, it takes four months from the time we receive a letter until we publish it.

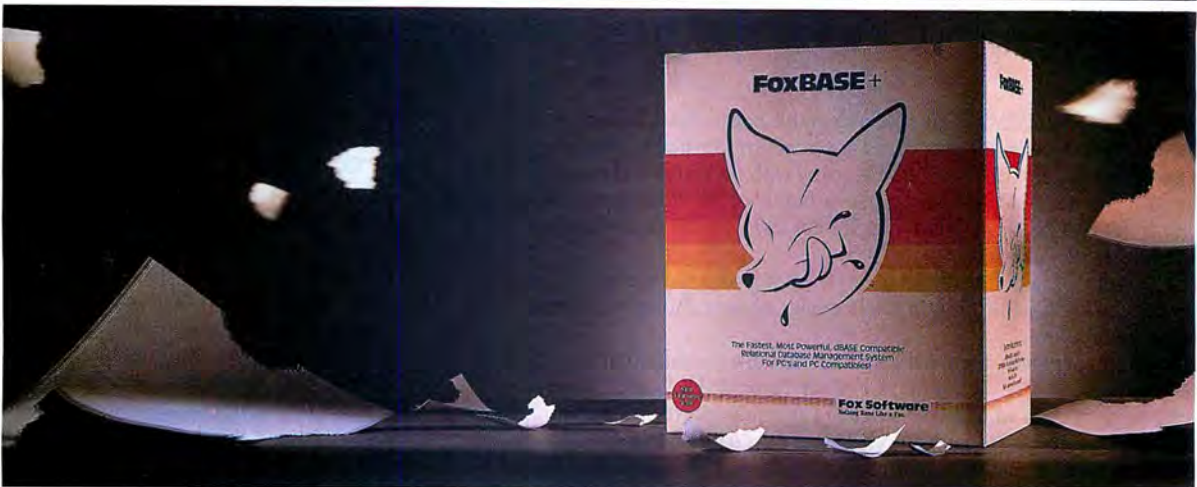
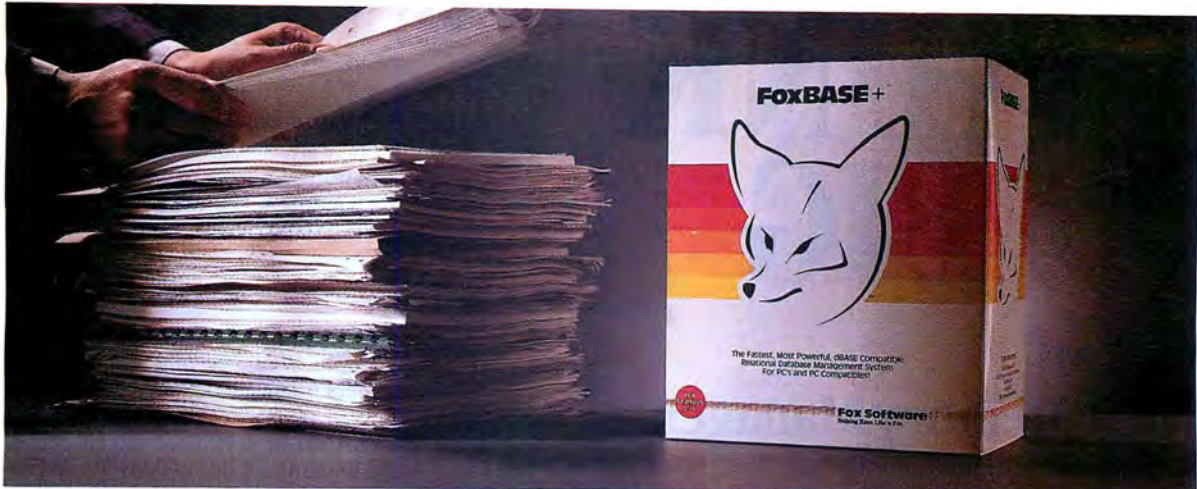

THE FOXBASE+ EFFECT

Nothing gets through your workload faster than FoxBASE+. Because no other database package has more timesaving features.

Speed is something every manufacturer claims. But we'd quickly point out that FoxBASE+ outpaces every other package in popular tests by margins so staggering, you'll wonder how you ever managed with ordinary software. In fact, FoxBASE+ 2.10 is the fastest dBASE-compatible database system.

Most publishers claim "compatibility" too. But the fact that you often have to re-write parts of your program is curiously omitted. That's why you'll appreciate FoxBASE+'s ability to run all your dBASE applications immediately – without changes.

FoxBASE+ not only supports the dBASE standard, but also allows you to enhance your applications with special features which include two-dimensional arrays, user defined functions, filtered indexes and new commands to create pop-up and pull-down menus.

Best of all though, is the term "user friendly". Often a misnomer for weeks of training with mind numbing manuals. Hardly easy.

That's why FoxBASE+ includes features that enable you to get working right away.

FoxCentral is a new type of user interface. Using pull-down and pop-up menus, you can perform every important database operation without programming!

FoxView is a screen design tool that helps you create beautiful custom data input screens.

FoxCode is our new applications generator that can easily produce the simplest or most sophisticated applications for you.

You can even document your programs automatically with **FoxDoc** by simply pressing a few keys.

FoxBASE+ is available in a variety of versions for the most popular operating environments including MS/PC DOS, Macintosh and UNIX/XENIX. There's even a 386 version! FoxBASE+/LAN supports an unlimited number of users on a network (No LAN PACKS required). Our Unlimited Royalty-Free Runtime allows extremely economical distribution of an unlimited number of your applications without incurring any royalty fees.

And if you want to add another dimension to your data use FoxGraph, the exciting new graphics package from Fox.

Take a look at FoxBASE+ today. You won't find a more powerful dBASE-compatible relational database management system. FoxBASE+ is retails for \$395, FoxBASE+/LAN for \$595 and FoxGraph for \$295 at your local quality software dealer. Or call 419/874-0162 for more information and a free demo-package. Ask for extension 320.

dBASE is a registered trademark of Ashton-Tate.
FoxBASE+ is a trademark of Fox Software Inc.

Fox Software
Nothing Runs Like a Fox.

Fox Software Inc. 118 W. South Boundary Perrysburg, OH 43551 Phone #: 419/874-0162 FAX #: 419/874-8678 Telex #: 6503040827 FOX
Fox Software International Intech House Cam Centre Wilbury Way Hitchin Herts SG4 OAP Tel: 0462 42 1999 Fax: 0462 42 13 18

THINK BIG

Phar Lap Virtual Memory Manager.

It will let you write applications up to 5, 10, 15 megabytes or more for any 386 PC running MS-DOS*. *Forget about RAM limitations.* Your application can run on a machine with as little as 1 or 2 megabytes of memory.

Only Phar Lap 386|VMM* gives you demand-paged virtual memory capability so you can write mainframe-sized applications for the PC. Applications your customers can run on their 386 PCs now with no additional memory. No kidding. All you need is 386|VMM and our family of 386 development tools. Existing programs developed with our 386|DOS-Extender can be easily expanded with 386|VMM too.

Our tools let you take full advantage of the 386 protected mode architecture. Break the DOS 640K limit in the language of your choice; C, Fortran, Pascal, or Assembler.

For fast compact code, use 386|ASM, our 80386 assembler that's upwardly compatible with the MASM* 8086 assembler. Existing DOS and mainframe applications written in a high level language are easily ported by recompiling. And 386|LINK, our 32-bit native mode linker, puts it all together.

Debugging is made easy too. With our 386 symbolic debugger you can debug applications written in assembler or any high level language. Best of all, with Phar Lap's 386|DOS-Extender* you can run your native mode program on any 386-based PC running MS-DOS. And you have full access to DOS system services through INT 21.

NO COMPATIBILITY PROBLEMS

Phar Lap's tools are compatible with the industry's leading systems: DESKPRO 386*, IBM Model 70/80*, 386 clones and accelerator boards. Not only will your new applications be compatible with the leading systems, they'll run alongside all other DOS applications.

NO ROYALTY PAYMENTS

Once your 386 application is complete, all you pay is a low one-time fee to license 386|DOS-Extender for redistribution.

386|VMM is also developer friendly. Call to find out about our flexible run-time pricing.

You can unlock the entire DOS market now. Don't wait for OS/2.

- \$495 386|ASM/LINK-Package includes 386 assembler, linker, MINIBUG debugger and the developer version of 386|DOS-Extender
- \$895 MetaWare 80386 High C* compiler
- \$595 MicroWay NDP Fortran-386* compiler
- \$195 386|DEBUG symbolic debugger
- \$295 386|VMM - developer version of the Phar Lap Virtual Memory Manager

(617) 661-1510

PHAR LAP SOFTWARE, INC.

60 Aberdeen Avenue, Cambridge, MA 02138

Fax: (617) 876-2972

"THE 80386 SOFTWARE EXPERTS"



chronization. They can't be used for mutual exclusion of critical regions of code, like the semaphore primitives, because executing a signal for an event will re-start *all* processes waiting on that event.

Lex Borger
Mission Viejo, CA

Multuser Advantages

In your *IBM Special Edition* (Fall 1988), there is considerable discussion about the roles of OS/2 and local-area networks (LANs) in workplace computing. While I found these discussions interesting and enlightening, I am puzzled by the lack of concern that OS/2 is not a multiuser operating system.

To quote from the text box "OS/2 versus Unix: Is DOS Compatibility the Key?" by Jason Levitt on page 112, "OS/2 is not a multiuser system, but advances in networking and distributed software will eventually make this a moot point." This view ignores an important advantage of multiuser systems: the ability to function as a "compute server" for a workgroup.

Consider a small academic department that needs access to a large computer for number crunching but that also does a lot of word processing and smaller tasks. To facilitate the numerical work, the department might buy a large 80386 machine. Resources wouldn't permit buying a separate 80386 machine for each user but would provide for individual basic IBM PC AT clones and a low-volume LAN. This arrangement would not permit sharing the 80386 machine because the operating system (DOS or OS/2) wouldn't permit remote log-ins from LAN stations. Hence, to share the 80386 machine, you'd need to sit at the keyboard attached to the machine. This is inefficient and awkward. The 80386 could be used as a file server, but then each of the remote stations would need the hardware resources to run the analysis software, again increasing costs.

A multiuser operating system would permit the use of the 80386 machine as a remote "compute server." Even if the system were set so that only one person could log on at a time, this would be a major improvement over the current options with OS/2. I hope Microsoft will consider this type of situation in its future plans for OS/2.

Nicholas Birkett
Ottawa, Ontario, Canada

Short Dispute

In your Product Focus entitled "80386s for the Masses" by Steve Apiki and Stan-

continued

PC EXPERTS AGREE:



Proteus® offers the fastest for the least, and supports them the most.

Proteus® sells the fastest personal computers you'll find. But as experts from BYTE, InfoWorld, Personal Computing, and others have discovered, our computers are more than just fast.

They're also an excellent value. You can't find better performing computers at lower prices.

And Proteus allows you to custom configure a system to your exact specifications.

Finally, Proteus provides you with 15 months of Free on-site service and support. And if you're not

satisfied with Proteus equipment within 30 days, you can return it for a full refund.

These are the reasons why the experts are so impressed with Proteus. And they're not alone. NASA, Xerox, GE, RCA, Dupont, GM, Revlon, General Dynamics, the U.S. Government, the U.N., MIT, Harvard, and Cornell have all become big Proteus users.

For the fastest, most economical, best supported computers available, follow the experts to Proteus.

"This IBM-compatible is so fast I have had trouble measuring its speed."

Business Computer Digest

"The Proteus is one of the fastest desktop computer systems we tested, a zero-wait-state hot rod."

InfoWorld Magazine

"Proteus is markedly faster than any other personal computer we've worked with, including Deskpro 386/20."

Personal Computing Magazine

"... the favorite system of our technicians because of its speed."

InfoWorld Magazine

PROTEUS-286GTX

12MHz, ZERO WAIT STATE

- Intel 80286-12 CPU
- 640K RAM expandable to 16MB
- 32KB cache memory
- 8 expansion slots
- 2 serial & 1 parallel port
- 1.2MB floppy drive or 3.5" microfloppy
- Dual HD & floppy controller
- 200W power supply, 110/220V
- 101 key tactile keyboard
- 15-month free on-site service
- Made in U.S.A.

Complete Systems

with Hard Disk and Monitor:

- 20MB mono \$1,995
- 20MB VGA color \$2,502
- 20MB (16-bit) VGA \$2,780
- for 40MB add \$150
- for 80MB add \$440



PROTEUS 386/16

16 MHz opt. 20MHz

ZERO WAIT STATE

- Intel 80386 CPU at 16 MHz
- Optional 80386—20 MHz
- 1MB RAM—Expandable to 16MB
- Intel 82385EE cache ctr.
- 32K fash cache
- 2 serial & 1 parallel port
- 1.2MB floppy drive
- Dual HD & floppy controller
- 200W power supply, 110/220V
- 101 key tactile keyboard
- 15-month free on-site service
- Made in U.S.A.

Complete Systems \$2,195

with Hard Disk and Monitor:

- 40MB 28ms mono \$2,899
- 40MB 28ms VGA color \$3,299
- 40MB 28ms VGA plus \$3,699
- for 80MB add \$175
- for 100MB add \$614
- for 150MB add \$1,525
- for 340MB add \$2,675



PROTEUS 386/25

25MHz, ZERO WAIT STATE

- Intel 80386 CPU at 25 MHz
- 1MB RAM expandable to 32MB
- Intel 82385EE cache ctr.
- 32K fash cache
- 387 coprocessor support
- 2 serial & 1 parallel port
- Dual HD & floppy controller
- 200W power supply, 110/220V
- 1.2MB floppy drive
- 101 key tactile keyboard
- 15-month free on-site service
- Made in U.S.A.

Complete Systems \$3,995

with Hard Disk and Monitor:

- 40MB 28ms mono \$5,199
- 40MB 28ms VGA color \$5,669
- 40MB 28ms VGA plus \$6,069
- for 80MB add \$175
- for 90MB add \$1,125
- for 150MB add \$1,525
- for 340MB add \$2,675



PROTEUS POWER

EXTRA PROTEUS POWER WITH CUSTOMIZATION

- 1:1 interleave controller
- ESD1 HD up to 700MB
- microfloppy drives
- tape streamers, 40MB to 225MB
- coprocessors
- brand name monitors and cards
- floor-stand configuration on all models
- custom configuration on all models



To order, call us direct. 1-800-782-8387

For 24 hr catalog, call 1-800-548-5036 using your modem set at 1200 or 2400B/N/8/1.
 Technical Support Hotline: 1-800-541-8933 Reseller/VAR programs available.

All trademarks recognized. © Proteus is a registered trademark of Proteus Technology Corp. All prices, terms, specs subject to change.

Circle 185 on Reader Service Card

proteus
 THE INTELLIGENT CONCLUSION

377 Route 17S, Airport 17 Center
 Hasbrouck Heights, NJ 07604

FEBRUARY 1989 • B Y T E 27

**What looks like DOS,
acts like DOS,
is easy like DOS,
can hook everybody up
and keep 'em hopping
from program to program,
and costs less than
an office chair?**



The Comfortably Affordable (and already available) PC-MOS.™

If you can afford a nice leather chair for your office, you can afford a multi-user, multi-tasking operating system that's just as comfortable to use.

PC-MOS incorporates breakthrough technology that allows you to fully harness the power and capabilities of 80386-based computers, while maintaining the compatibility and ease of

use of DOS. So now you can have up to 25 inexpensive terminals driven by a single 80386 processor. You can continue to use your favorite software programs like Lotus 1-2-3,™ dBASE III,™ and WordPerfect,™ and you can keep using those familiar DOS commands like DIR and COPY. You can even run all those terminals as a single cluster

connected to a Novell server.

PC-MOS comes in single, five and 25-user versions starting at \$195. Your satisfaction is guaranteed or you get a complete refund.

For more information about PC-MOS and the name of the authorized dealer nearest you, call 1-800-451-LINK. Then you can sit back and relax.



THE SOFTWARE LINK

3577 PARKWAY LANE • NORCROSS, GEORGIA 30092
INSIDE GEORGIA: 404-448-5465 • FAX: 404-263-6474
INTERNATIONAL CALLS: 404-263-1006

PC-MOS is a trademark of The Software Link, Inc. All other brand names are the trademarks of their respective holders.

Circle 213 on Reader Service Card (DEALERS: 214)

FEBRUARY 1989 • BYTE 29

ford Diehl (October 1988), we were pleased to note that our Zeos 386 Tower was the fastest 16-MHz machine reviewed. We appreciate your many favorable comments as well.

One criticism of all systems reviewed was that the connecting cables are too short. The Zeos tower-style configuration was noted as having shorter cables. This is not the case.

Zeos normally ships, at no additional charge, a full set of extension cables with

each 80386 tower-style system ordered. This includes monitor power, signal, and keyboard extension cables. This standard extension cable set provides plenty of length to work with.

Zeos shipped BYTE two systems for review. The first system was completely standard and included extension cables. Unfortunately, it was damaged in shipment. We replaced the cabinet with a second one but didn't send another cable set. BYTE already had the extension cables

and the other system components.

Zeos makes every effort to provide its customers with complete ready-to-run systems—including extension cables with our tower-style systems.

Greg Herrick
President, Zeos International
St. Paul, MN

Factoring the Unforeseen

I would like to contribute to the recent "Minds vs. Programs" correspondence (Letters, September 1988).

In the late 1960s in England, I developed one of the first expert systems, although we did not use that expression then, to analyze predigitized optical data from an elementary particle physics experiment. The program was developed on an IBM 360/75 in FORTRAN, which was about the only language available at that time. I played a major part in its development, especially in the pattern recognition.

Eventually, it achieved a 99.9 percent pattern-recognition efficiency for single particle tracks. It also had to have a very high background recognition efficiency, because the signal-to-noise ratio in the data was 1 to 2200. We found it hard to make this better than 1 to 100 and were forced to plot the data on 16mm film (using a Ferranti Atlas) and scan the data by eye to eliminate the rest of the noise. To maintain both a high pattern-recognition efficiency and a high background rejection efficiency, I developed a hierarchical system of self-adjusting selection criteria—in effect, rules that changed themselves in a systematic way if they failed to succeed.

This work gave me considerable insight into the problems of computer pattern recognition. My conclusions are as follows:

- The human intellect is capable of holding an abstract representation of what it is seeking in its consciousness and of comparing that with what it has found.
- The human intellect is capable of detecting when its algorithms or techniques have not yielded the desired solution.
- The human intellect is driven by emotions, which a computer does not have. It can generate new algorithms to achieve its goal, new goals if the previous one is in error, or even new emotions to create a more satisfactory reality.
- A computer lacks this fundamental consciousness and creativity.

continued

3 1/2 INCH 1.4 MB DISKS FOR ONLY ONE DOLLAR!

New Invention Makes It Possible!

Do you use the new, high capacity, 3 1/2 inch disks? If so, you have paid four, five, even six dollars per disk! Byte for byte, that is as much as SIX TIMES the 'old' 360K floppies. Now you can convert all your programs, data, and files to the new format, WITHOUT PAYING THESE PRICES!

How Is This Possible? Have you ever tried to format a regular, 'low density' 3 1/2 inch disk to 1.44 MB? Of course you have! It doesn't work! The computer gives an invalid media error. Our company was putting in a large network of IBM Clones. We have grown from a small company to a million-dollar corporation in two short years, and we didn't do it by wasting money. So, of course, we tried to use the cheap, 720K disks. Total failure.

Enter our Crackpot Engineer. Our Crackpot Engineer wondered what was the difference between the disks. He tore them apart, analyzed the media. He found NO DIFFERENCE WHATSOEVER! Yet, they would not format. Why? Then he started examining the plastic housing. And he found the difference. It is NOT in the media, IT IS IN THE PLASTIC CASE!

Total Failure! Our Crackpot Engineer (among other things, he invented the Electronic Flea Collar) sent a brand-new 720K disk to our machine shop, and asked them to modify it. They did... and the DISK IMMEDIATELY FORMATTED! But, within 10 minutes of use, it totally failed. It lost data all over the place. Back to the drawing board. The disk was dis-assembled and examined. It was found that, in performing the conversion, a microscopic piece of plastic had entered the housing, and totally ruined the disk. It was obvious that, if the conversion could be done reliably, it required extreme precision.

Enter Our Other Crackpot Engineer Our president is a mechanical engineer. One of the best in the country. While a research scientist at Colorado School of Mines, he completely revolutionized the field of water jet drilling. He tackled the problem. Finally he came up with a solution - a precision tool which could perform the modification EVERY TIME and leave no plastic particles which would damage the disk!

Months of Testing We then commenced on a testing program. We modified and formatted thousands of disks, and tested them for data integrity. Out of one thousand disks, one would not format, two had one bad track. NOT ONE LOST ANY DATA! We then put a disk on a computer with a bat file which copied data to a disk, read and checked every byte, then copied the data back to the disk. The program ran 24 hours a day, for TWO SOLID WEEKS without even one error! We were finally convinced that the procedure was reliable enough for a product.

Our Offer. Here is our irresistible offer. Purchase our DoubleDisk Converter for the price of \$29.95. If you are not COMPLETELY SATISFIED, return the DoubleDisk. You will receive a FULL REFUND! What is more, if a disk ever does not convert properly, send us the disk, and we will send you a 1.44MB disk from a major manufacturer in exchange!

You Can't Lose! You will save MORE THAN THE PURCHASE PRICE IN CONVERTING ONLY YOUR FIRST TEN DISKS! From that point on, it is all profit. After converting only 100 disks, and after deducting the cost of the DoubleDisk, you will have saved AT LEAST \$425.00! Quite a return for an investment of only \$29.95! Credit Cards and Checks Accepted!

Purchasing our DoubleDisk is easy! Simply call our 800 number. We accept all major credit cards. Or, return the coupon below, and we will ship you one immediately. We Will gladly accept your personal check.

24 HOURS ORDER TOLL FREE - 1-800-537-4226 7 DAYS
(In Colorado call 303-872-8945)

YES! I want to try your DoubleDisk on your UNCONDITIONAL MONEY BACK GUARANTEE! I enclose only \$29.95 plus \$3.50 Shipping and Handling (California residents add \$1.80 Sales Tax) for each DoubleDisk Converter. If I am not COMPLETELY SATISFIED, I will return the DoubleDisk for a FULL REFUND! If any disk ever fails to convert, I will send it to you and you will IMMEDIATELY send me a 1.44MB Disk in exchange!

Name _____ Address _____

City _____ State _____ Zip _____ Telephone _____

Send To: Biological Engineering, Inc., DoubleDisk Offer
2674 Main Street, Ventura, CA 93003 Phone 805-644-1797

Now you can grab, store, and process 16 images in Real Time on the PC AT.



The many faces of Fred Molinari, President.

The DT2861 Arithmetic Frame Grabber can process 4 times as many images as any other frame grabber built for the PC AT.

With a built-in processor, the DT2861 also lets you process 4 images in parallel, or switch display instantaneously from as many as 16 images. The DT2861 grabs images off virtually any video source,



including CAT scanners, scanning electron microscopes, line-scan cameras, as well as ordinary video cameras and VCRs. It even ships with IRISstutor™ software—for free!

For more information about the Frame Grabber

that's 4 times better than anything else made for PCs, give us a call today.

Call (508) 481-3700

In Canada, call (800) 268-0427

◀DT-Connect™ is an open interface specification which permits the direct connection of stand-alone data acquisition and frame grabber boards to processor boards for greatly accelerated signal (DSP) and image processing.



Image Processing Board	Computer	Resolution	Gray Levels	RS-170, NTSC, RS-330, CCIR, PAL Compatible	VCR Compatible	Slow Scan	Number of Video Inputs	Real-Time Frame Grab	On Board 8-bit ALU	Memory-Mapped Frame-Store Memory	Zoom, Pan, Scroll	Software Support	Price
DT2861 Frame Grabber	IBM PC AT	512x512	256	Yes	Yes	0-12 MHz	8*	Yes	Yes	16 buffers 512x512x8 each (4 Mbytes)	Yes	DT-IRIS IRISstutor	\$5995

*With DT2859 1/2 size multiplexer board (\$395).

DATA TRANSLATION®

World Headquarters: Data Translation, Inc., 100 Locke Drive, Marlboro, MA 01752-1192 USA, (508) 481-3700 Tlx 951646

United Kingdom Headquarters: Data Translation Ltd., The Mulberry Business Park, Wokingham, Berkshire RG11 2QJ, U.K. (0734) 793838 Tlx 94011914

West Germany Headquarters: Data Translation GmbH, Stuttgarter Strasse 66, 7120 Bietigheim-Bissingen, West Germany 07142-54025

International Sales Offices: Australia (2) 662-4255; Belgium (2) 735-2135; Canada (800) 268-0427; Chile (2) 25-3689; China (408) 727-8222; (1) 868-721; Denmark (2) 274511; Finland (90) 372-144; France (1) 69077802; Greece (1) 951-4944, (31) 527 039; (1) 361-4300; Hong Kong (5) 448963; India (22) 23-1040; Israel (3) 32-4298; Italy (2) 82470 1; Japan (3) 348-8301, (3) 502-5550, (3) 355-1111; Korea (82) 756-9954; Morocco (9) 30-4181; Netherlands (70) 99-6360; New Zealand (9) 504759; Norway (2) 53 12 50; Peru (14) 31-8060; Philippines 818-0103; Portugal 545313; Singapore 7797621; South Africa (12) 8037680/93; Spain (1) 455-8112; Sweden (8) 761-7820; Switzerland (1) 723-1410; Taiwan (2) 918-4740; United Kingdom (0734) 793838; West Germany 07142-54025.

Data Translation is a registered trademark of Data Translation, Inc. Other brands and products are trademarks of their respective holders.

Circle 69 on Reader Service Card

FEBRUARY 1989 • BYTE 31

In effect, the human being is like an infinitely sophisticated, self-conscious, self-programming computer. We know, for example, that we are seeking peace and will go on adjusting our search until we have found a stable and lasting peace, for otherwise we shall be destroyed. A computer would be incapable of this self-regulation. It would execute its algorithms until it self-destructed: It would not be motivated to avoid self-destruction or be capable of reprogramming itself to

avoid self-destruction.

There are people who would invariably argue that this is not so, that a computer could be programmed with this self-motivation and reprogramming capability. But even if that were so, the computer would not be capable of generating the required emotional response to a problem whose existence the programmer had not foreseen, because it would not understand meaning. This is the difference between consciousness and ma-

chine. The key word is *programmed*. A program has the consciousness of the programmer frozen in it. It is crystallized consciousness, rather than living consciousness.

Dr. R. J. Ellis
Palo Alto, CA

FIXES

• In the article entitled "The Promise of Project Management" by Lamont Wood (November 1988), we accidentally omitted the address for the consulting firm One Soft Decision, Inc. One Soft publishes PM Solutions, an in-depth report on project management software. For more information, contact Dan Yahdavi, One Soft Decision, Inc., 573 Wakerobin Lane, Suite B, P.O. Box 6123, San Rafael, CA 94903

• Our November 1988 Short Take on the NEC Ultralite laptop computer failed to mention some key points about the unit we reviewed. As the article states, the machine was an engineering prototype. We did not explicitly mention, however, that the ROM disk hardware was not fully implemented. It could not work, period. The LapLink and DOS Manager software resides in a ROM chip in the laptop, not on ROM cards, as the article says. We also omitted the fact that the Ultralite comes with a serial cable to use with the 9-pin, DIN-style connector.

As an update, NEC has told us that a number of popular applications software packages have been converted to the ROM card format, including Lotus 1-2-3, Agenda, WordPerfect 5.0, WordStar 5, Microsoft Works, XyWrite III, and NEC's Telcom 2.0 communications software.

Finally, the Short Take compared the Ultralite's list price to a Toshiba T1000's street price. The T1000's list price is \$1249.

• Our PostScript Printer Product Focus (September 1988) gave incorrect scores for the GCC Business Laser Printer for graphics and text quality. The numbers for those categories in table 1 on page 166 should read 3.255 for graphics quality and 3.318 for text quality. BYTE regrets the error.

• Two photographs were inadvertently swapped in the What's New section of the October 1988 issue. The photograph on page 78 is actually of a LabView 2.0 screen, as described on page 80. The photograph on page 80 is a screen from Absoft's MacFortran/AUX, which is described on page 78.



GRASP

Graphic
Animation
System for
Professionals

Animation tools that "far outshine those of other popular graphics presentation packages." —PC Magazine

Program in the 4th Dimension...
ANIMATE!

Get unlimited action and interaction with the most powerful PC animation system available, by calling Grasp routines from your programs in C, Pascal, Basic, and other languages.

Or develop your graphics applications directly in Grasp! Take advantage of:

- 74 animation & effects commands
- 25 predefined fades
- single-command animation
- all major graphics modes
- screen capture and graphics printing utilities

Includes Pictor, a full-featured paint program, completely integrated with Grasp for fast development and editing of programs and graphics.

GRASP 3.1

\$149

Convince yourself!

Send us \$2.00 for Episode I
"The Adventures of Ferguson Floppy"

Paul Mace

SOFTWARE

400 Williamson Way
Ashland, OR 97520
800-523-0258

NRI's new at-home training gives you the computer, the software, and the hands-on skills to start a high-paying career as a computer programmer

Now NRI gives you hands-on experience in computer programming with a powerful IBM-compatible computer system and software you keep. One easy step at a time, you build full-featured, powerful programs in BASIC, Pascal, C, and COBOL—today's hottest computer languages. One easy step at a time, you train to be a high-paid computer programmer!

Your NRI training includes a computer, modem, and invaluable programming software you keep

Unlike any other course, NRI's at-home training in Computer Programming gives you hands-on experience with a powerful, IBM-compatible Packard Bell VX88 computer system, including 2400 baud internal modem, 512K RAM, disk drive, and invaluable programming software—BASIC, Pascal, C, and COBOL—all yours to keep.

With NRI, you get the skills and the confidence, the computer and the software to build real-world, working programs for a wide variety of business, personal, and professional applications . . . in all, everything you need to step into today's top computer programming jobs.

No previous experience necessary

No matter what your background, NRI ensures you get the know-how you need to take full advantage of every exciting opportunity in computer programming today.

With your experienced NRI instructor always available to help, you quickly cover the fundamentals, then



Carl Barone
Programmer/Analyst
NRI Schools

move on to master all four of today's key computer languages—BASIC, Pascal, C, and COBOL—step by easy step. Before you know it, you have what it takes to handle any programming problem you're likely to encounter in your professional career.

Now, as never before, you can succeed as a computer programmer

The best news comes from the Bureau of Labor Statistics: As a programmer trained in a variety of computer languages you

can land the programming position of your choice—even make it on your own as an independent programmer. There's no doubt about it—with NRI's complete, at-home, four-language training in Computer Programming, you can write your own ticket to success in this high-paying, top-growth computer career field!

See other side for highlights of your NRI hands-on training in BASIC, Pascal, C, and COBOL →

SEND CARD TODAY FOR FREE NRI CATALOG

YES! Please rush me my FREE catalog describing NRI's at-home training in Computer Programming.

Name _____ Age _____
(please print)

Address _____

City _____ State _____ Zip _____
5401-029

Your NRI training in computer programming includes an IBM-compatible Packard Bell VX88 computer with internal modem, 512K RAM, disk drive, monitor, and programming software—BASIC, Pascal, C, and COBOL—all yours to keep!



Now, with NRI, you can learn to program in today's hottest computer languages— BASIC, Pascal, C, and COBOL

You start with BASIC, an extremely popular language used for graphics, teaching, personal, and small business applications.

Next, you master Pascal, a multipurpose language often used to develop software for computer-aided design (CAD).

You move on to C—hands down, today's hottest computer language—used for everything from systems programming to artificial intelligence.

You wrap up your training in programming with COBOL, the language of business and the most widely used computer language in the world.

NRI's new at-home training in Computer Programming starts by walking you step by step through the fundamentals, easing you into programming with brilliantly detailed instructions, charts, and diagrams.

In no time at all, you have a complete understanding of the programming techniques used every day by successful micro and main-frame programmers. And then the fun really begins.

With your personal NRI instructor on call and ready to help, you use the computer system included in your training to actually design, code, run, debug, and document programs in BASIC, Pascal, C, and COBOL. Then, following easy-to-read instructions, you use your modem—also included—to “talk” to your instructor, meet other NRI students, even download programs through NRI's exclusive programmers network, PRONET.

Send for your FREE catalog today

For all the details about NRI's at-home training in Computer Programming, send the postage-paid reply card today. Soon you'll receive NRI's fascinating, information-packed, full-color catalog.

Open it up and you'll find vivid descriptions of every aspect of NRI training. You'll see the IBM-compatible Packard Bell computer included in your course up close in a special, poster-sized foldout section. And, best of all, you'll find out how your NRI training will make it easy for you to build a high-paying career—even a business of your own—in computer programming.

If the card is missing, write to NRI at the address below.

IBM is a registered trademark of the IBM Corporation

SEND CARD TODAY FOR FREE NRI CATALOG

BUSINESS REPLY MAIL

FIRST CLASS MAIL PERMIT NO. 10008 WASHINGTON, D.C.

POSTAGE WILL BE PAID BY ADDRESSEE

NRI SCHOOLS

McGraw-Hill Continuing Education Center

3939 Wisconsin Avenue
Washington, D.C. 20077-9265

NO POSTAGE
NECESSARY
IF MAILED
IN THE
UNITED STATES

NRI
School of Computer Programming

McGraw-Hill Continuing Education Center
3939 Wisconsin Avenue
Washington, DC 20016



CHAOS MANOR MAIL

*Jerry Pournelle answers questions about his column
and related computer topics*

One Alternative to OS/2

Dear Jerry,

I use an IBM PS/2 Model 80 for development work as well as in my normal, day-to-day activities. It consists of a 70-megabyte hard disk drive, 2 megabytes of system memory, a 3½-inch internal floppy disk drive with drives A and B, an Identica internal tape backup using SYTOS software, a 5¼-inch external SYSGEN floppy disk drive for transporting files and programs to and from the other systems, and an IBM color monitor.

It was with this Model 80 that I encountered problems. I wanted to take advantage of the speed and memory available by using a multitasking operating system called PC-MOS/386 from The Software Link. My objective, therefore, was to partition the hard disk as three logical drives (C, D, and E); partition the 2-megabyte system memory as three virtual machines to allow three programs to run simultaneously under the PC-MOS/386 operating system; use the 5¼-inch external disk drive to maintain compatibility with other IBM PC, XT, and AT computers and clones through the SYSGEN Bridge device driver; and use the internal tape drive to regularly back up and restore logical drives C, D, and E using SYTOS software.

The SYTOS tape backup software, however, would not run. Calls to The Software Link and Identica confirmed that the two could not work together. My system operated under PC-MOS, but SYTOS would work only under DOS.

I called a local turnkey systems house familiar with PC-MOS; the people there had experienced a similar problem on a Compaq 386, but they had no experience with a Model 80 or with the SYSGEN external drive. They explained that they had solved their problem with Disk Manager from Ontrack Computer Systems in Eden Prairie, Minnesota. I called Ontrack, and, with no guarantee of success, I bought the company's Disk Manager.

First I copied all my files to 3½-inch floppy disks, since all the data on my hard disk would be destroyed. Then, booting with DOS in drive A, I refor-

matted the hard disk under DOS 3.1 with one bootable DOS partition and one extended DOS partition on the hard disk, which was further split into two logical drives. I copied all DOS files from drive A to drive C.

The CONFIG.SYS file was as follows:

```
DEVICE=BRIDGE.DRV /PS60:2
DEVICE=ANSI.SYS
FILES=15
```

I then ran the SYSGEN installation program from drive A, telling SYSGEN that there were two 3½-inch internal drives. I copied all SYSGEN files from drive A to drive C.

Although I had not run Disk Manager's installation yet, I copied all Disk Manager's files to drive C. I then rebooted the computer from drive C. During the boot, a message was displayed announcing that the SYSGEN drive was installed as drive F.

At this point, I formatted 10 3½-inch disks, adding the DOS system to only one disk. Since this disk would be the DOS boot disk, I copied all files on drive C to this disk.

Although the CONFIG.SYS file on drive A could have been edited, I chose to create a new configuration file for drive A:

```
DEVICE=DMDRIVER.BIN
DEVICE=BRIDGE.DRV /PS60:2
DEVICE=ANSI.SYS
FILES=15
```

Since the SYSGEN external drive was now "live," I copied all the PC-MOS/386 software from drive F to drive C and to another disk in drive A (not the DOS boot disk). I also transferred several

continued

Jerry Pournelle holds a doctorate in psychology and is a science fiction writer who also earns a comfortable living writing about computers present and future. He can be reached c/o BYTE, One Phoenix Mill Lane, Peterborough, NH 03458, or on BIX as "jerry."

NEW BLAISE TOOLS



*The fastest way to create
powerful programs
with Turbo Pascal
5.0 and Turbo C 2.0!*

Blaise Computing, manufacturer of function libraries that offer easy-to-use solutions to your programming needs, introduces:

POWER TOOLS PLUS/5.0—\$149

—completely integrated and lightning-fast routines to help you:

- ◆ Add moving bar pull-down menus and windows to your user interfaces; *NEW!* ◆ Generate context sensitive help screens; *NEW!* ◆ Add easy-to-use date and time conversion routines; *NEW!* ◆ Let users choose from window oriented pick lists; *NEW!* ◆ Create and access "huge" data structures; *NEW!* ◆ Use multiple-line edit fields with fully configurable edit keys; *NEW!* ◆ Speed up your sorting with flexible in-memory sort routines; *NEW!*
- ◆ Add EMS support; *NEW!* ◆ Write TSRs and ISRs easily; ◆ Control DOS memory allocation;
- ◆ Create powerful programs in Turbo Pascal 4.0 & 5.0!

Turbo C TOOLS/2.0—\$149

—light, fast, high quality functions to help you:

- ◆ Add easy-to-use mouse support for windows and menus; *NEW!*
- ◆ Quickly include virtual windows and menus; *NEW!*
- ◆ Integrate your windows and menus with Turbo C's text windows; *NEW!* ◆ Create context-sensitive help screens; *NEW!*
- ◆ Provide multiple-line edit fields with fully configurable edit keys; *NEW!* ◆ Use keyboard and video services (including enhanced keyboard and VGA); *NEW!*
- ◆ Write TSRs and ISRs easily; ◆ Create powerful programs in Turbo C 1.0, 1.5 and 2.0!

FREE with these products!

Source code, complete sample programs, a comprehensive reference manual with extensive examples, the Norton Guides Instant Access Program, and an online database. We also offer free technical support and a bulletin board system dedicated to technical issues.

Unleash your programming potential!

Blaise Computing offers programming tools that are fast, flexible and affordable. Call now to order or to ask for a free brochure on our full line of products for C and Pascal.

Put Blaise tools to the test!

If at any time during the first 30 days you are not completely satisfied with their speed and flexibility, we'll refund your money.

Call 800-333-8087 today!

BLAISE COMPUTING INC.
2560 Ninth St., Suite 316, Berkeley, CA 94710, (415) 540-5441
FAX: 415-540-1938

*Turbo C and Turbo
Pascal are trade-
marks of Borland
International.*



other files from drive C to the disk in drive A by typing the following at the C> prompt:

```
MSYS A:
COPY DMDRVR.BIN A:
COPY ANSI.SYS A:
COPY BRIDGE.DRV A:
```

At the A> prompt, I wrote a new CONFIG.SYS file for drive A:

```
DEVICE=DMDRVR.BIN
DEVICE=BRIDGE.DRV /PS60:2
DEVICE=ANSI.SYS
MEMDEV=$386.SYS /p
FREEMEM=C4000,C8000
FREEMEM=CA000,E0000
DEVICE=$SERIAL.SYS
SMPSIZE=256K
BUFFERS=22
```

Since the disk in drive A was the PC-MOS/386 boot disk, I rebooted from drive A under PC-MOS/386.

To prepare the hard disk for PC-MOS/386, I ran HDSETUP from drive A, allowing PC-MOS/386 to create three logical MOS disks. I then transferred the PC-MOS/386 system to drive C. At the A> prompt, I typed

```
MSYS C:
COPY *.* C:
```

Rebooting now from drive C restarted the machine under the PC-MOS/386 operating system. The next step was to prepare the hard disk with Disk Manager.

With the Disk Manager software in drive A, I typed DM/C/M to invoke Disk Manager in the color, manual mode. Looking at the partition information, the partitions were as follows:

```
1 0 30 DOS Y TSL 1.01
2 31 61 DOS N NOSYSTEM
3 62 69 DOS N NOSYSTEM
```

I changed partitions 2 and 3 to write/read. Exiting from Disk Manager and allowing the changes to be saved to disk, I received a MOS error message, which I could ignore.

Finally, the tape backup software, SYTOS, was installed. After all, the goal of all this was to allow SYTOS to function. To install SYTOS, I ran the installation program from drive A. Since SYTOS must be present on the hard disk, I copied all the files from drive A to a subdirectory named SYTOS on drive D.

This is working fine for me. Booting from drive C under PC-MOS/386 allows multitasking and other PC-MOS/386

functions. Under PC-MOS/386, my system will run dBASE III Plus, WordStar, Multiplan, BASIC, Quickcode, Quicksilver, Chart-Master, Norton Utilities, and other programs. The system will not run Microsoft's Excel. Although I haven't tried it, Microsoft's Windows probably will not run, either. Booting from drive A under DOS using a 3½-inch DOS boot disk will allow the SYTOS tape backup to run properly. You can also run any other software not supported under PC-MOS/386, such as Microsoft's Excel.

Arthur J. Foley
Central Islip, NY

Thanks for the report. You do seem to have found one alternative to OS/2. It would be interesting to see if Windows/386 would run with this system; probably not.

I don't have a Model 80.—Jerry

N.B.: Nota Bene

Dear Jerry,

You once said that you just might move up to XyWrite III Plus after all. That would be a good move. But might I suggest a better one? Move a bit further on and get Nota Bene.

First, some history. They say you never forget your first love or your first word processor. I haven't forgotten my first word processor, or any of the others, but I truly love my current one, Nota Bene. It's extremely powerful, smooth, fast, and (most important) logical.

As you may know, Nota Bene is a customized version of XyWrite. Most commands in Nota Bene can be executed in three ways: by typed-in commands, by function keys, and by menus. Most operations can be initiated by short mnemonic command codes. To give you an example of how easy the command codes are, search is se, search backward is seb, absolute search (where case is matched) is sea, and search backward absolute is seba.

You can throw away the function key template. (I dare you to do that with WordPerfect.) The key use is supremely logical. For example, the Control key works on words; the Shift key on sentences; Control-Shift on phrases (i.e., material between punctuation); Alt works on paragraphs; Shift-Alt works on lines. These keys in combination with other keys will move the cursor, delete, highlight, interchange text, and so on—all operating on the same units. It is easy to learn these operations in minutes. It is my understanding that Nota Bene, be-

cause of its logical design, is infinitely easier to use than XyWrite.

Nota Bene is designed for academic use. It has all kinds of footnoting, indexing, formatting, and printing capabilities (there are three disks filled with printer drivers). It has a text base that lets you index everything you write and recall it with a variety of Boolean-type queries. It has its own programming language. It has six alternate keyboards that you can instantly access: You can type in a variety of languages, including Greek; you have a keyboard of math symbols. You can also create and load your own keyboards.

The bad news about Nota Bene is that the manual is over 1000 pages long. The good news is that the program is so logical that you can use it without reading the manual.

With a 30-minute introduction at the keyboard and with the reference booklet, you can do very well. One reason is that there are also a menu structure and help file that are seamlessly integrated. If you don't remember the commands, you can call up the menus.

Several weeks ago, my 15-year-old son saw me writing with Nota Bene and asked for a run-through. I gave him a 15-minute overview, thinking that it was enough to satisfy his request and to get him turned back to his own word processor. Later, when I got off the computer, he sat down and used Nota Bene to write a fairly long essay that was due the next day. For sure, I had to do some prompting, but he did a fine job. He has used Nota Bene ever since (with little help from me) and loves it. He doesn't do anything fancy, but the point is that he can navigate it alone with his relatively simple documents. That tells you a lot about a word processor that is so powerful.

Why am I telling you this? Because Nota Bene is really good, and the people at Dragonfly Software deserve success. (Incidentally, the company's technical support is excellent.)

I have introduced dozens of people to Nota Bene. I have never encountered a single person who did not switch to it after he or she played with it for a bit.

Joseph M. Prospero
Miami, FL

Thanks for the report.

You aren't the only one who's said good things about Nota Bene, and indeed, I've already recommended the program to a young person writing a dissertation.

Alas, I haven't tried it myself, because I don't have it.—Jerry ■

BUFFALO[®] SL

ONLY \$500 PLUS \$100 PER 256KB MEMORY

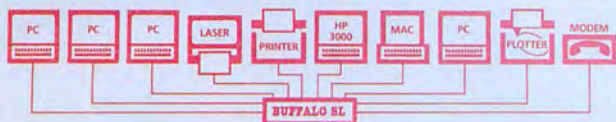

When you can't afford to buy a laser for each PC, the **Buffalo SL[™]** is the inexpensive way to let everyone share - not just your lasers, but printers, plotters and modems as well. If you don't need simultaneous access to shared files, the **SL** is also an alternative to a LAN at a fraction of the cost.

The **SL** has four parallel and six serial channels, with all ten being user configurable as either an input or an output, so you can share 1 PC with 9 peripherals, 9 PCs with 1 peripheral, or any combination in between. If you need more than ten channels, you can link several **SLs** together. All channels can be in use at the same time and can rapidly transfer and queue data. The **SL** even allows your PC to send data at 19,200 baud. All memory (user upgradeable up to 4MB) is dynamically allocated and shared as needed.

The **SL** comes with software for menu-driven installation and pop-up menu control selections, but you don't have to be a programmer to use it. Of course, the **SL** works just fine without our software too! The **SL** has many other features so ask us to send you more information.

MORE[™] MEMORY

The Memory Extension System[™] Board

When 640K just is not enough, you need to add **MORE[™] MEMORY**. This **Memory Extension System[™] Board** uses only one slot in any 8 or 16 bit bus and can be used as expanded, extended and/or conventional memory (EEMS/EMS version 4.0 software).

MORE MEMORY is compatible with PC/XT/AT computers and supports PC-DOS, MS-DOS, PC-MOS, OS/2, Unix, Xenix, etc. It is easy to install **MORE MEMORY** and it comes with a **5 YEAR WARRANTY**.

MORE MEMORY has built-in DRAM protection that corrects for any memory errors when you reboot, so you will never have to replace a faulty memory chip. No downtime or costly repairs will ever occur due to a failed memory chip on the **MORE MEMORY** board.

HYPERWARE[™] PC productivity boosting software is included **FREE** with each unit. **HYPERDISK[™]** enables disk drive read/write intensive programs to run 3-10 times faster. **HYPERKEY[™]** enhances the responsiveness of your keyboard. Sold separately, \$49.95.

2MB-\$1200, 4MB-\$2100, 6MB-\$3000, 8MB-\$3900



Buffalo Products also makes other smaller buffers, automatic switches, and interface conversion devices. All of our products come with a **45 DAY MONEY BACK GUARANTEE**. Call us **TOLL FREE** and talk to one of our friendly application technicians for solutions to your connectivity problems.

(800) 345-2356

Buffalo Products, 2805 19th Street SE, Salem OR 97302 (503)585-3414

PRESENTING AMERICA'S HOTTEST NEW CORPORATE JETS.

FIVESTAR Computers.

**Taking companies higher.
And farther.**

It's no wonder hundreds of corporations across the country are now flying high-performance computers from FIVESTAR. That's because FIVESTAR delivers the quality and power companies need to soar to new levels of capability - while keeping hardware costs down to earth.

A ONE YEAR LIMITED WARRANTY—and ON-SITE SERVICE.

Every FIVESTAR Computer comes with a ONE YEAR LIMITED WARRANTY. For companies with critical applications, a comprehensive ON-SITE SERVICE CONTRACT is available for just \$99. In most cases, service calls are made within 24 hours.

The FIVESTAR 286/10.

The high performance computer that flies through complex business applications.

CPU/MEMORY: 80286 16-bit microprocessor • 6/10MHz user selectable • 0 wait states • 13.3MHz LANDMARK throughput rating • Socket available for 80287/10 math coprocessor • 512KB RAM expandable to 4MB RAM • Supports LIM/EMS 4.0 on the motherboard

BIOS: AWARD BIOS • Set-up utility in firmware • Fully supports DOS and OS/2

EXPANSION SLOTS: Eight full-length slots: two 8-bit, six 16-bit

PRICE: \$995

The FIVESTAR 386/16 SX.

A faster corporate jet for companies running on tight schedules - and tight budgets.

CPU/MEMORY: 80386-SX 16/32-bit microprocessor • 8/16MHz user selectable • 0 wait states • Socket available for 80387/16 math coprocessor • 1MB RAM expandable to 4MB RAM (on motherboard) • Uses 256KB or 1MB DRAMS

BIOS: AMI BIOS • Set-up utility and diagnostics in firmware • ROM BIOS and video BIOS in shadow RAM • Fully supports DOS and OS/2

EXPANSION SLOTS: Eight full-length slots: two 8-bit, six 16-bit.

PRICE: \$1,495



The FIVESTAR 386/16.

The hot machine that'll take your company to new heights of productivity.

CPU/MEMORY: 80386 32-bit microprocessor • 8/16MHz user selectable • 0 wait states • 24.0MHz LANDMARK throughput rating
 • Socket available for 80387/16 math coprocessor • 1MB RAM expandable to 10MB RAM 32-bit memory • Uses 256KB/1MB DRAMS

BIOS: AMI BIOS • Set-up utility and diagnostics in firmware • ROM BIOS and video BIOS in shadow RAM
 • Fully supports DOS and OS/2

EXPANSION SLOTS: Six full-length slots: one 8-bit, four 16-bit, one 32-bit.

PRICE: \$1,995

The FIVESTAR 386/20.

For companies that want to reach high altitudes in a hurry - and leave the competition far behind.

CPU/MEMORY: 80386 32-bit microprocessor • 6/20MHz user selectable • 0 wait states • 30MHz LANDMARK throughput rating
 • Socket available for 80387/20 math coprocessor • 1MB 32-bit RAM expandable to 16MB RAM • 64KB (static RAM) cache memory • Uses 1MB SIMMS

BIOS: AMI BIOS • Set-up utility and diagnostics in firmware • Fully supports DOS and OS/2

EXPANSION SLOTS: Eight full-length slots: two 8-bit, five 16-bit, one 32-bit.

PRICE: \$2,495

All models shown also come equipped with:

- RS-232 serial port • Centronics parallel printer port • 101-key enhanced keyboard with separate numeric and cursor control keypads • real-time clock/calendar with battery back-up
- 200WT power supply (110/220V switchable).

Order by phone today.

Call FIVESTAR to discuss your company's computer needs. (And don't forget to ask about our new 386/25.) We'll have you flying in no time!

1-800-752-5555

FIVESTAR
COMPUTERS

America's hottest new corporate jets.

Circle 88 on Reader Service Card

All prices and specifications are subject to change without notice.

FIVESTAR is a registered trademark.

ASK BYTE

BYTE technical editors answer your questions on microcomputing

Proper Mindset

I recently came into a Mindset computer. The operating manual is so deficient that I cannot use it. Where can I get a workable technical manual? Also, I need a memory map of the computer and its expansion unit. A schematic would be nice, too.

C. Bradner Brown
Kensington, MD

Your best bet would be to link up with a computer group in your area (check Computer Shopper for a list of club meetings) or to investigate the orphan computer special-interest groups on CompuServe. Barring that, I believe a Mindset computer is still on display in the New York Museum of Modern Art as an example of innovative package design. Perhaps you could see if the museum needs a backup.—R. G.

Incompatible Drive?

I have several Shugart Associates Model 450R floppy disk drives that have been used on a computer for writing to Unix, MS-DOS, and PC-DOS floppy disks. I don't seem to be able to jumper any one of them so that it will be accepted as a valid disk drive on my IBM PC AT clone, which is a PC's Limited system. I've tried listing the drive on my setup menu as a 360K-byte disk drive. Is it possible to use these disk drives on my machine?

M. W. P. Strandberg
Cambridge, MA

The Shugart SA450 should work with your system as a 360K-byte drive, provided that your controller can support an additional drive set to 360K bytes. My guess is that you have improperly jumpered the drive select lines. These are controlled by the jumper header labeled 2D on the floppy disk drive's printed circuit board.

To enable drive select 0, short pins 2 and 13; to enable drive select 1, short pins 3 and 12. If your floppy disk drive cable is like most, it has a "twist" in it between the first and second floppy disk

drive connectors, in which case you need to jumper both drives for drive select 0. (Nothing's easy anymore, is it?) You'll also want to cut the jumper between pins 6 and 9, which would otherwise cause the drive to respond to any drive select signal. Finally, make sure that only the last drive on the daisy-chained cable has a terminating resistor pack installed (this is IC 3D on the 405). Good luck.—R. G./S. W.

IN ASK BYTE, BYTE editors answer questions on any area of microcomputing. The most representative questions will be answered and published. Send your inquiry to

*Ask BYTE
One Phoenix Mill Lane
Peterborough, NH 03458*

Due to the high volume of inquiries, we cannot guarantee a personal reply. All letters and photographs become the property of BYTE and cannot be returned.

More Lines, Please

After my pleasant experiences writing EGA and VGA graphics routines using QuickBASIC 4.0, I was disappointed to find that Microsoft C version 5.1 (running under DOS) offers no obvious way to alter the number of text lines on a graphics display. I suspect it's just a matter of making the correct DOS call with the right parameters. Am I correct?

John J. Ottusch
Malibu, CA

Richard Wilton is an excellent source for the kind of information you need. I suggest you check the following articles and books:

"PS/2 Video Programming," BYTE's Inside the IBM PCs, Fall 1987

"VGA Video Modes," BYTE's IBM Special Edition, Fall 1988

Programmer's Guide to PC and PS/2 Video Systems (Microsoft Press, Redmond, WA: 1987)

In particular, Wilton's BYTE articles cover the topic of changing the number of text lines on the display.—R. G.

FFT Woes

I am a senior electrical engineering student at the Milwaukee School of Engineering. One of the requirements for graduation is the successful completion of a full-year design sequence that results in a working prototype.

I am working on a "digital demodulator" project that is based on an article in the September 1986 *IEEE Transactions on Instrumentation and Measurement*. It's essentially a radio receiver that detects the information on a carrier using digital signal processing techniques instead of conventional analog demodulation circuitry.

Part of the project will involve using the fast Fourier transform for spectral analysis, but apparently the FFT is a real time burner. I need information on FFT algorithms and, in particular, on implementing FFT algorithms in assembly language. In addition, do you have any information on predicting FFT response time?

Eric R. Schumann
Milwaukee, WI

Steve Ciarcia's "Computers on the Brain" articles (starting in the June 1988 BYTE) cover the FFT algorithm in some detail. Also look into "Faster Than Fast Fourier" (April 1988 BYTE).

E. Oran Brigham's The Fast Fourier Transform (Englewood Cliffs, NJ: Prentice Hall, 1974) is an exhaustive exploration of Fourier transform techniques as well as the FFT. It contains the source code for the FFT algorithm (in ALGOL and FORTRAN).

Finally, see if you can locate a copy of Minicomputer Systems, Organization, Programming, and Applications by Richard H. Eckerhouse Jr. and L. Robert Morris (Englewood Cliffs, NJ: Prentice Hall, 1979). It contains a brief discussion of the FFT but includes PDP/11-compatible assembly language source

continued

When 30MB just won't do...

Seagate's ST251 Family of 40, 60 and 80MB drives

If 30 megabytes just isn't enough to satisfy your disc storage requirements, then Seagate's 5.25" ST251 family offers the capacity, performance and interface options you need for any operating environment.

The cornerstone of our family is the best-selling ST251. Available in both ST412 and SCSI interfaces, with either 28 or 40 msec access time, this 42MB drive is perfect for demanding applications.

For 50% more capacity, our ST277 features 64MB of formatted storage, with the same access time options as the ST251. And for performance-driven, high-capacity applications, our 84MB

ST296 has a 28 msec access time and an SCSI interface.

Each drive in the family comes complete with utility software for easy installation and drive partitioning. You can configure the right solution for your computer system by choosing from Seagate's own line of controllers and adapters for the ST251 family.

No matter which model you choose, you'll receive the same high quality and reliability that have made Seagate the first name in disc drives worldwide. For more information on the ST251 family, contact your authorized Seagate Distributor, or call Seagate at 800-468-DISC.

 **Seagate**

The first name in disc drives



Integrand's new Chassis/System is not another IBM mechanical and electrical clone. An entirely fresh packaging design approach has been taken using modular construction. At present, over 40 optional stock modules allow you to customize our standard chassis to nearly any requirement. Integrand offers high quality, advanced design hardware along with applications and technical support all at prices competitive with imports. Why settle for less?

Rack & Desk PC/AT Chassis

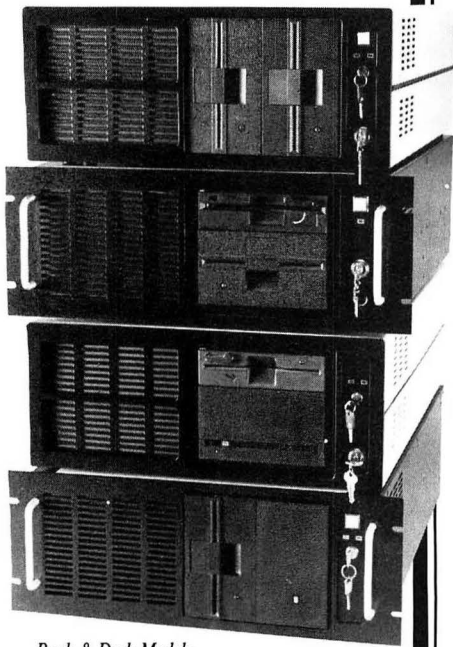

Rack & Desk Models

Accepts PC, XT, AT Motherboards and Passive Backplanes

Doesn't Look Like IBM

Rugged, Modular Construction

Excellent Air Flow & Cooling

Optional Card Cage Fan

Designed to meet FCC

204 Watt Supply, UL Recognized

145W & 85W also available

Reasonably Priced

INTEGRAND

RESEARCH CORP.

Call or write for descriptive brochure and prices:
8620 Roosevelt Ave. • Visalia, CA 93291
209/651-1203

TELEX 5106012830 (INTEGRAND UD)

EZLINK 62926572

We accept BankAmericard/VISA and MasterCard

IBM, PC, XT, AT trademarks of International Business Machines. Drives and computer boards not included.

ASK BYTE

code for an FFT butterfly. You might be able to use this code as a jumping-off point to whatever processor you're using.—R. G.

Good Old Model III

I have several questions. First, where can I get inexpensive parts for project construction? Second, I have an old Tandy TRS-80 Model III, and I wonder if its Z80 CPU will work with the programs in Steve Ciarcia's book. Finally, the Model III is 8 years old. I'd like to know if there's any way I can upgrade it.

Michael L. Hudin
Oroville, CA

Check out the advertisements in the back of BYTE and other computer and electronics magazines for distributors of parts.

I'm not sure to which of Steve Ciarcia's books you are referring, so I can't advise you about software. The TRS-80 Model III was a fine computer for its time. Tandy still supports the machine, and you can order more RAM, floppy and hard disk drive kits, and an RS-232C board from your Tandy Computer Center or Radio Shack dealer. Another source for parts is Aerocomp (2544 West Commerce St., P.O. Box 223957, Dallas, TX 75212, (214) 637-5400).—S. W.

Teaching an Old BIOS New Tricks

I have a 6-year-old IBM PC that has 16K-byte RAM chips on the motherboard. I want to increase the base memory to 640K bytes through the use of an Everex board, but I am told that my ROM BIOS will not allow me to get above about 545K bytes. I need updated ROM chips, but IBM no longer supports them, and I haven't been able to find them locally. I hardly think I'm the only one in this position; there must be many such machines still in use. Can you refer me to a source for the chips I need?

W. E. Van Horne
Columbus, OH

When IBM first introduced the IBM PC, the original BIOS limited system memory to 544K bytes. IBM never expected that anyone would want more RAM. Upgrade BIOS ROM chips are available from Mentor Electronics (7560 Tyler Blvd., Suite E, Mentor, OH 44060, (216) 951-1884).—S. W.

More Interface Cables

I am an electrical engineering student at the University of Illinois. I have finally decided to construct several of the projects presented by Steve Ciarcia, and I

want to interface them to my Macintosh SE. What can I do to make the standard RS-232C connections match the RS-422 mini DIN-8 connector on the back of my computer? I also wonder about how this nonstandard input via the modem port affects the communications protocol and toolbox interface with the Microsoft FORTRAN and Turbo Pascal environments with which I am familiar.

Last semester, I worked on a sleep-monitoring project through the College of Medicine, and I'd like to continue with some research on my own with the HAL EEG presented in the June 1988 BYTE. I understand that some time ago, Steve Ciarcia wrote an article describing the measurement of other bodily functions. In which issue of BYTE can I find this article?

Peter Apostolakis
Long Grove, IL

The RS-422A standard arose out of the need to send serial signals at higher rates and through longer lengths of cable. It does this by using differential voltages to provide noise immunity. However, the RS-422A standard was also designed to be electrically compatible with the older RS-232C standard. This is done by picking off the unbalanced negative portions of the transmitted and received data signals. This reduces the problem of obtaining RS-232C-compatible signals from the Mac SE's serial port to a matter of building the appropriate cable. I've successfully built cables that connected a Macintosh serial port to a PC serial port for data transfers.

For a Mac mini DIN-8 to DB-25 RS-232C cable, you need to purchase connectors for the cable. You can get the DB-25 connector from any electronics supply shop. Getting your hands on a male mini DIN-8 connector is a lot harder, and definitely more expensive. You can get an Apple System Peripheral-8 cable, product number M0197, for \$29 from an Apple dealer. This cable has a mini DIN-8 connector at each end. Cut the cable in half, pick the half to which you want to attach the DB-25 connector, and store the other half in a safe place. See figure 1 and table 1 for pin-out information.

The Mac has its own drivers that handle I/O through the serial ports. The extent to which you can send and receive data or manipulate control signals through these ports depends on how well the programming language has implemented its interface to the Mac's serial drivers. Check the details in your programming language manual. You can

continued

MINUTEMAN[®]

UNINTERRUPTIBLE POWER SUPPLIES



“More Powerful Than Ever!”

INTRODUCING
THE NEW
900 WATT
MODEL
120 VOLT

TOTAL POWER PROTECTION

- BLACKOUTS** Enables user to operate during complete loss of power.
- BROWNOUTS** User is protected from low AC voltage below 102 volts.
- OVERLOADS** Automatic shutdown in overload situation to protect UPS from inverter burnout.
- OVERVOLTAGE** UPS runs on inverter (117 volts) when AC voltage exceeds 132 volts.
- SURGES/SPIKES** Clamps transients above 200 volts with an energy rating of 100 joules or less.
- EMI/RFI** Three stage filtering for clean AC power.



- **FULL ONE YEAR WARRANTY**
- **ORDER-SHIP SAME DAY**
- **1 MILLISECOND TRANSFER TIME***
- **SYNCHRONIZED SINEWAVE***

*250 watt and 500 watt units offer 4 msec transfer time, PWM waveform



1455 LeMay Dr.
Carrollton, TX 75007

Telephone:
(214) 446-7363

1-800-238-7272

FAX: (214) 446-9011 TELEX: 140275 OMEGA

Power Output	120 Volt Models	230 Volt Models
250 WATT	\$ 379.00	\$ 429.00
300 WATT	\$ 549.00	N/A
500 WATT	\$ 699.00	\$ 799.00
600 WATT	\$ 899.00	\$1049.00
900 WATT	\$1249.00	N/A
1200 WATT	\$1499.00	\$1749.00
1600 WATT	\$1999.00	\$2299.00

Suggested Retail



Optional Battery Packs Not Shown



Why the FREE Inmac catalog is the computer accessory you'll value most.

You get "a store in a drawer."

Page after page of PC products that make work easier, more effective. At your fingertips, when you wish.

Plain talk makes it all easy.

Spacesavers, workstations, cables, disks. All explained in simple language & pictured as you'd use 'em. Call with any questions: Our informed staff helps you get the right item, instant credit, fast delivery.

The final decision is yours.

Unlike some catalog firms, Inmac lets you decide when you're satisfied with a product. A promise we back up with ironclad guarantees.

Call now toll free:

1-800-722-4770
Ext. 2438

Use the resource that gives the world's sharpest business computer users an extra edge.



Call or send coupon to
Inmac, 2465 Augustine Dr.,
Santa Clara, CA 95054.

YES!

Send my first Inmac catalog today!

Name

Title

Company

Street Address/P.O. Box

City State Zip

Area Code Phone No. Code 5545

In Canada, Call Toll Free 1-800-387-2173

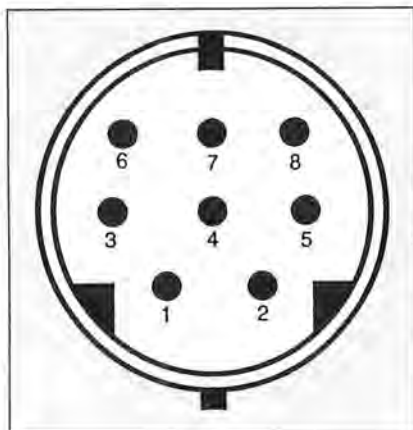

Figure 1: DIN-8 connector pin-out diagram.

Table 1: Wiring the Macintosh DIN-8 to a DB-25 connector involves connecting the pins as shown. Note that the signal names are from the Mac's point of view.

Signal Name	DIN-8 pin	DB-25 pin	Null modem function
HSK	2	20	DTR handshake for printer
TxD-	3	3	Null modem
GND	4	7	Signal ground
RxD-	5	2	Null modem

also look into *Inside Macintosh, volume II*, starting on page 243 for good information on the Macintosh serial drivers.

Steve Ciarcia's previous article on bio-feedback, "Mind Over Matter," appeared in the June 1979 BYTE. —T. T.

I've Got This Spare...

I have an Amiga 1000 with 512K bytes of internal memory. I also have an extra Amiga Model 1050 256K-byte RAM cartridge, the one that plugs into the front of the machine. I'd like to know if there is any way I can modify the spare pack so that I can use it to increase my memory to 768K bytes.

R. James de Graff
Winnipeg, Manitoba, Canada

The odds are you'll do more harm than good trying to modify the board. I recommend getting one of the sidecar memory boxes that attach to the expansion connector on the right of the machine. Keep your spare cartridge as just that: a spare.

If you're still determined to hack your machine's memory, check out the article "Build Your Own 256K Amiga Expansion RAM" in the February 1987 BYTE. —R. G.

Rays and Buses

I am interested in ray tracing, a very calculation-intensive computer application that is similar, in some respects, to the problem of generating pictures of the Mandelbrot set; it can be done using a multiprocessor board (like the one described by Steve Ciarcia in "A Supercomputer, Part 1" in the October 1988 BYTE).

I have an Apple Macintosh II, which uses the NuBus. I've been programming the Mac for years, but since the previous versions of the Mac had no slots, I know nothing about hardware. I hear that designing and programming NuBus cards is easy, but I don't know where to begin.

Could you suggest some reading material for programmers who, like me, have never soldered anything, let alone built any hardware? Could you also present an article describing how to build a simple NuBus test card for the Mac II? Or how about a multiprocessing board like the one Steve Ciarcia built to generate Mandelbrot sets?

Ajay Nath
Oakland Gardens, NY

Unfortunately, designing and programming NuBus cards is not easy. The software interaction with boards is complicated, and you need an intimate understanding of how the hardware operates. But the end result of all this effort is a card that you can plug into a Mac II without requiring you to tinker with switches on the board or run complex configuration applications.

As for your request for an article on this subject, I've got good news for you. The design of a simple NuBus test card is described in the *Macintosh Special Edition* (December 1988 BYTE). If you need additional information, you can consult the books *Designing Cards and Drivers for the Macintosh II and Macintosh* by the Apple Computer staff (Reading, MA: Addison-Wesley, 1987) and *Macintosh Family Hardware Reference*, also by Apple Computer (Reading, MA: Addison-Wesley, 1988). These should at least give you an idea of what is involved in such a project, and sample code is provided to help you get started. —T. T.

Vertical vs. Horizontal Drives

My AT takes up entirely too much room on my desk, and the fan and my new

continued

Because Resources Should Be Shared



BayTech engineers Printer Sharing.

Make the most of your investments in valuable printers, computers, plotters, modems, and other resources with a printer-sharing device from BayTech. We manufacture a diverse product line engineered for flexibility and speed that lets you share your resources and maximize your investments.

From simply sharing one or more printers between computers, to creating a complete network for printer sharing and computer-to-computer communication, BayTech has a device designed to meet your specifications.

Call toll free today to learn more about maximizing your resources.

Circle 33 on Reader Service Card

BayTech



*Bay Technical Associates, Inc.,
Data Communications Products Division
200 North Second St., P.O. Box 387,
Bay Saint Louis, MS 39520 USA
Telex: 910-333-1618 BAYTECH.
Telephone: 601-467-8231 or toll-free
800-523-2702, EXT 981*

Never buy another ribbon! with MacInker™

over 100,000 sold

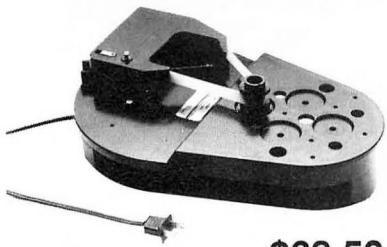

Universal Cartridge MacInker **\$68.50**



Imagewriter or Epson MacInker **\$42.00**

Eliminate expensive ribbon replacement with the famous MacInker. The Universal Cartridge MacInker (\$68.50) will re-ink most cartridges with the appropriate adaptor. The Universal Spool MacInker will re-ink all spools. Operation is very simple & automatic. Our extra dark, lubricated ink yields better than new printout quality and its cooling effect extends print-head life. New ink dispenser ensures precise ink metering. Average number of re-inkings/cartridge is 60-100 at an average cost of 5cents/re-inking. We also have dedicated MacInkers for special cartridges. All MacInkers, with appropriate Multicolor Adaptor can re-ink multicolor cartridges (2 or 4 colors). Or use your MacInker to re-ink in 10 different colors: red, green, blue, yellow, purple, brown, orange, gold and silver. Our Customers range from individuals to Fortune 500 Corporations. In 1982 we pioneered re-inking technology and are dedicated to its development. We have a complete range of accessories, heat-transfer re-inking adaptors, special inks and cartridges.

New

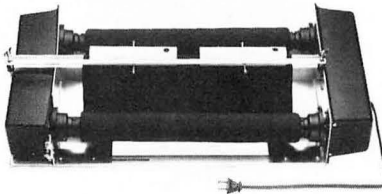

Band Printer MacInker **\$299.00**

- Universal Cartridge MacInker68.50
- Multicolor Adaptor (specify printer)40.00
- Imagewriter I/II MacInker mod 234 IM42.00
- Epson MacInker mod 271EP42.00
- Universal Spool MacInker68.50
- Heat Transfer Adaptor40.00
- Extra Ink bottle3.00 pint18.50

Call for free catalog

Special Offer

Just say, "I saw it in 'Byte' and get a free mousepad with any order >\$60.00, or free key-beeper & flashlight combination for orders >\$100.00.

Buy the Universal Cartridge & the Universal Spool at the same time and get the second unit for \$50.00

All MacInkers delivered with bottle of ink, ink meter, reservoir, reservoir cover. Black, uninked, colored, special cartridges available. Best ribbon quality at lowest costs.

Multiuser Printer Buffers

Let us configure the most economic & efficient buffer set-up when using two printers with one computer or two computers and two printers. We have the most complete range of buffers, converters, switches, cables & custom cables. Award winning Proteus switches manually or by software between 2 printers. Memory is automatically partitioned & both printers can print simultaneously.

- UG-411, 1 comp. / 1 printer
 - 64k160.00
 - 256k.....230.00
- UG-402 2 comp. / 2 printers
 - 64k.....199.00
 - 256k.....240.00
- PROTEUS, 1 comp. / 2 printers
 - 64k.....199.00
 - 256k.....240.00
- UG-403 4 comp. / 2 printers
 - 256k.....275.00
- UG-408 4 comp. / 4 printers
 - 512k.....375.00
- UG-412 Serial buffer card 1 MEG500.00
- CBL-715 Univ. ser-par-ser converter159.00
- CBL-705 Ser-par converter99.00
- Autoscanning switches (4 to 1)169.00



UG-402



Proteus

Satisfaction or 30 day refund on all products - Immediate shipment - Major credit cards

Computer Friends, Inc. Order Toll Free 1-800-547-3303

14250 NW Science Park Dr.
Portland OR 97229

in Oregon (503) 626-2291
fax (503) 643-5379 telex 4949559 CF

MiniScribe 43-megabyte full-height hard disk drive make more noise than I'd like. I've been considering buying one of those vertical stand brackets to put my machine under or beside my desk. However, I know that quite often the bearings in various types of machinery are designed to carry their load in only one position and if turned 90 degrees can fail rapidly. Disk drives, both floppy and hard, appear to be designed for horizontal installation; and since the bearings are obviously small, they might be prone to early failure if mounted vertically. Floppy disk drives, due to their intermittent running, might not be as much of a problem as hard disk drives. Am I worrying needlessly?

Is it possible to use a program to stop the hard disk drive from running constantly? I don't want to sound like a nervous Nelly, but the idea of that expensive thing sitting in there spinning madly 8 hours per day while I type makes me wonder how long it can live. Having it run when data is actually being accessed is one thing, but if I'm just writing and only occasionally saving to disk, why have the hard disk spinning needlessly?

I notice that most of the new 80386 computers built with tower cases have the drives mounted horizontally. They also have their switches mounted on the front, where they belong. As much as having a new 80386 machine appeals to the techno-freak in me, I simply cannot justify buying one to get that slick tower case. Can you tell me where I can buy a tower case like that? Three companies—Fortron, Logix, and Zeos—have tower cases that appear identical and suitable. I contacted Logix, but the company won't sell bare cases. Surely these three obtain their cases from the same source. Do you know where?

Harmon Seaver
Grand Marais, MN

Some disk drives can withstand vertical mounting; others cannot. That information should be included in the specifications. If not, check with the disk drive manufacturer.

Your hard disk's read/write head is floating on a cushion of air—created by the spinning platter—against zero friction. In this environment, the drive will not be exposed to abnormal wear and tear. In fact, your drive will experience greater wear if it is continually stopped and started as you propose. The roughest treatment of your drive occurs at power on, and the culprit is not so much friction as heat. Drive manufacturers go to great

continued

SYMANTEC

TIME LINE

Suggested Retail Price: \$595

3.0

KEY FEATURES:

Outline Gantt

Network View (PERT)

May 23, 1988

INFO WORLD THE PC NEWS WEEKLY

PROJECT MANAGEMENT SOFTWARE • REPORT CARD

	(weighting)	Harvard TPM II 2.0	Microsoft Project 4.0	Superproject Expert 1.0	Time Line 3.0
Performance		Good	Good	Very Good	Excellent
Features/flexibility	(225)	Satisfactory	Very Good	Very Good	Very Good
Recalculation speed	(75)	Satisfactory	Good	Very Good	Very Good
Leveling speed	(50)	Good	Very Good	Good	Excellent
Documentation		Very Good	Very Good	Very Good	Very Good
Ease of learning	(125)	Good	Very Good	Very Good	Excellent
Ease of use		Very Good	Very Good	Very Good	Very Good
Error handling	(150)	Good	Good	Good	Very Good
Data Integrity	(75)	Very Good	Good	Very Good	Very Good
Error messages	(25)	Good	Good	Very Good	Excellent
Support		Good	Satisfactory	Very Good	Very Good
Support policies	(50)	Good	Good	Good	Very Good
Technical support	(50)	Satisfactory	Good	Good	Very Good
Value		6.2	6.8	7.2	8.8

THE #1 PROJECT MANAGER IS BEHIND THE BEST COMPARATIVE REVIEW IN THE WORLD.

Just why is Time Line #1, review after review, evaluation after evaluation? Is it our advanced outline structure or true "what-if" analysis using unlimited undo/redo? Maybe it's our completely customizable Gantt charts, PERT charts, and form-driven reports. Could it possibly be the way we handle multi-project scheduling and resource allocation without having to manually link files?

We think Time Line is #1 because of its seamless combination of advanced technology and ease of use. But we're biased. Decide for yourself. Call now for a free Time Line demo disk (you may also qualify for our free corporate evaluation program). You'll see what "the best project manager in the World" can do for you.

The #1 Project Manager

FREE DEMO DISK, CALL (800) 228-4122 EXT. 429Y.



SYMANTEC™ Symantec Corporation, 10201 Torre Avenue, Cupertino, CA 95014. 408/253-9600.
*Time Line is the #1 best-selling project manager (survey of National Distributors). It is also the #1 choice of 48 of the Fortune 50. Time Line 3.0 (\$595) received InfoWorld's highest 1988 rating for project management software (8.8). Time Line was PC Magazine's Editor's Choice in 86, 87 and 88 and was rated #1 by Software Digest in 87 and 88. Training and consulting services, and links to CA-TELLAPLAN are available, call 415/898-1919. © 1989 Symantec Corporation

PC MAGAZINE Editor's Choice '86, '87 and '88

Circle 225 on Reader Service Card

FEBRUARY 1989 • BYTE 45

"IT MAKES PROCOMM LOOK LIKE AMATEURCOM."

If you talk to a DEC mainframe, no software emulates the VT220, VT100 or VT52 terminal more accurately or professionally than VTERM.*

Hot keys. Kermit. Automatic reformatting for spreadsheets and databases. VTERM has it all.

Why not join the 60,000 users of VTERM (many of whom moved up from Procomm). And try the DEC terminal emulation package that's in a totally different league.

FREE EVALUATION KIT.

Yes, send me a free time-limited, full-blown working copy of VTERM/220, which is mine to keep.

Name _____

Title _____

Company _____

Address _____

Telephone (____) _____

I am a user dealer . Mail to:

Coefficient Systems Corporation

611 Broadway, New York, New York 10012 (212) 777-6707 BYP-2/89

* VTERM refers to VTERM/220, VTERM/4010, etc. products from Coefficient Systems Corporation. Procomm is a trademark of Datastorm Technologies, Inc.

Questions? Want faster action? Call (212) 777-6707, ext. 402.

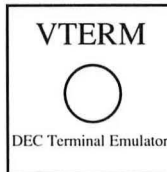

lengths to ensure proper heat compensation. Some of the new laptops shut down the drive motor when it is not in use, but they do this to preserve power, not to protect the drive. I do not recommend that you routinely shut down the drive motor.

I suggest you get a head parking utility. You can find these programs in the public domain. After a specified time of disk activity, the software will park your disk heads until a disk access is requested. A commercial product of this type is Safepark from Prime Solutions. Safepark positions the head over a selected sector that does not contain data. Power surges and sudden spikes can write random bits to your drive. If the bits are written to a sector where your data resides, that data is corrupted. Safepark moves the heads to the "safe zone" whenever the disk is not in use. I mention the product because it is included with a very useful disk utility package called Disk Technician.

Hard disks are most vulnerable to bad sectors. Some utilities, such as the Norton Utilities, will let you partition off bad sectors. Once you have done this, you can no longer access that sector. Disk Technician, on the other hand, performs preventive maintenance on the disk. It will monitor disk access errors and keep track of them. When DOS fails to read a sector, it will keep trying 30 to 50 times. If it finally does read the disk successfully, DOS goes on its merry way, not concerned about the access problem. Disk Technician will recognize the problem, differentiate between random errors and repeating errors, and then attempt to repair the error before it becomes a major problem. First it moves the data to a good sector, then it tries to repair the sector by performing a low-level format. If it can't repair the sector, it maps the sector out. I recommend the program for all those nervous Nellies who dread the thought of losing valuable data from hard disks.

Many independent mail-order companies sell the tower case. You just have to look around. I found one such case in a JDR Microdevices catalog (see the company's ads in the back of BYTE). The \$299.95 cost includes a 250-watt power supply, speed display, mounting hardware, faceplates, and a speaker. Make sure that you also find some cables that are long enough to accommodate the tower design. We keep getting these wonderful space-saving tower systems with cables so short that we can't place them on the floor where they belong. It will be frustrating if you invest in the tower case but end up with a bulky system on your desktop anyway, so you should keep cables in mind.—S. D. ■



A Brand New Resolution The Handy Scanner HS-3000

Free HALO DPE™

The handiest little scanner in the world just got even better. The Handy Scanner 3000 from Logitech offers you clarity and versatility in a little package. Like our other Handy Scanners, the Handy Scanner 3000 for the IBM PC, PS/2s and compatibles can handle almost all the jobs the desktop models can, but it's smaller and easier to use.

We give you the features you need the most in a Handy Scanner. The new 4-1/8" scanning width makes short work of the biggest pictures. You can switch the scanner between 400/300/200/100 DPI. For those really important pictures, the Handy Scanner 3000 lets you have it all with 400 DPI resolution. The real-time screen display lets you instantly see your scan, so you can quickly make scanner adjustments as necessary. With adjustable half-tones and contrast, you get a clean, clear picture. Two col-

ors, not one, are used to scan your originals, so colors such as red or reddish-skin tones can be scanned without losing detail.

The Handy Scanner 3000 comes complete with full-featured, powerful software for scanning, editing and merging text with your graphics. Saved scan files are compatible with almost all graphics software, including PageMaker, Ventura, WordPerfect 5.0 and many others. The package includes the scanner, interface card, the HALO DPE desktop publishing software package (worth \$195), a utility diskette and an instruction manual.

The Handy Scanner 3000 is a little scanner that does a lot, and now it does it even better.

\$299.95

ADDED SPECIAL NOW OCR SOFTWARE AVAILABLE

Converts scanned images from scanner into ASCII text for use with word processors, data bases, etc.

Reg. \$199.95 if purchased with HS-3000 ONLY

\$79.95

LOGITECH SCANMAN

- 200 dpi
- 4" scanning width
- IBM, PC, XT, AT, PS/2 (25 & 30)



Complete with Logitech™ "Scanware"™ Software

\$189.95

QUALITY CUSTOMER SERVICE 508-278-6555

TECHNICAL ASSISTANCE 508-278-6556



TOLL FREE ORDER LINE

1-800-635-0300

TRUE DATA PRODUCTS

115 MAIN ST., P.O. BOX 347
UXBRIDGE, MA 01569
508-278-6555
HOURS: MON-FRI. 9-6, SAT. 10-4 (EST)

CORPORATE P.O.'S WELCOMED

ALL PACKAGES SHIPPED UPS EXCEPT CANADA AND A.P.O.'S C.O.D.'S ADD \$2.30 MASTER CHARGE/VISA ADD 3% 1 YEAR WARRANTY UNLESS OTHERWISE NOTED PRICES TERMS CONDITIONS SUBJECT TO CHANGE WITHOUT NOTICE

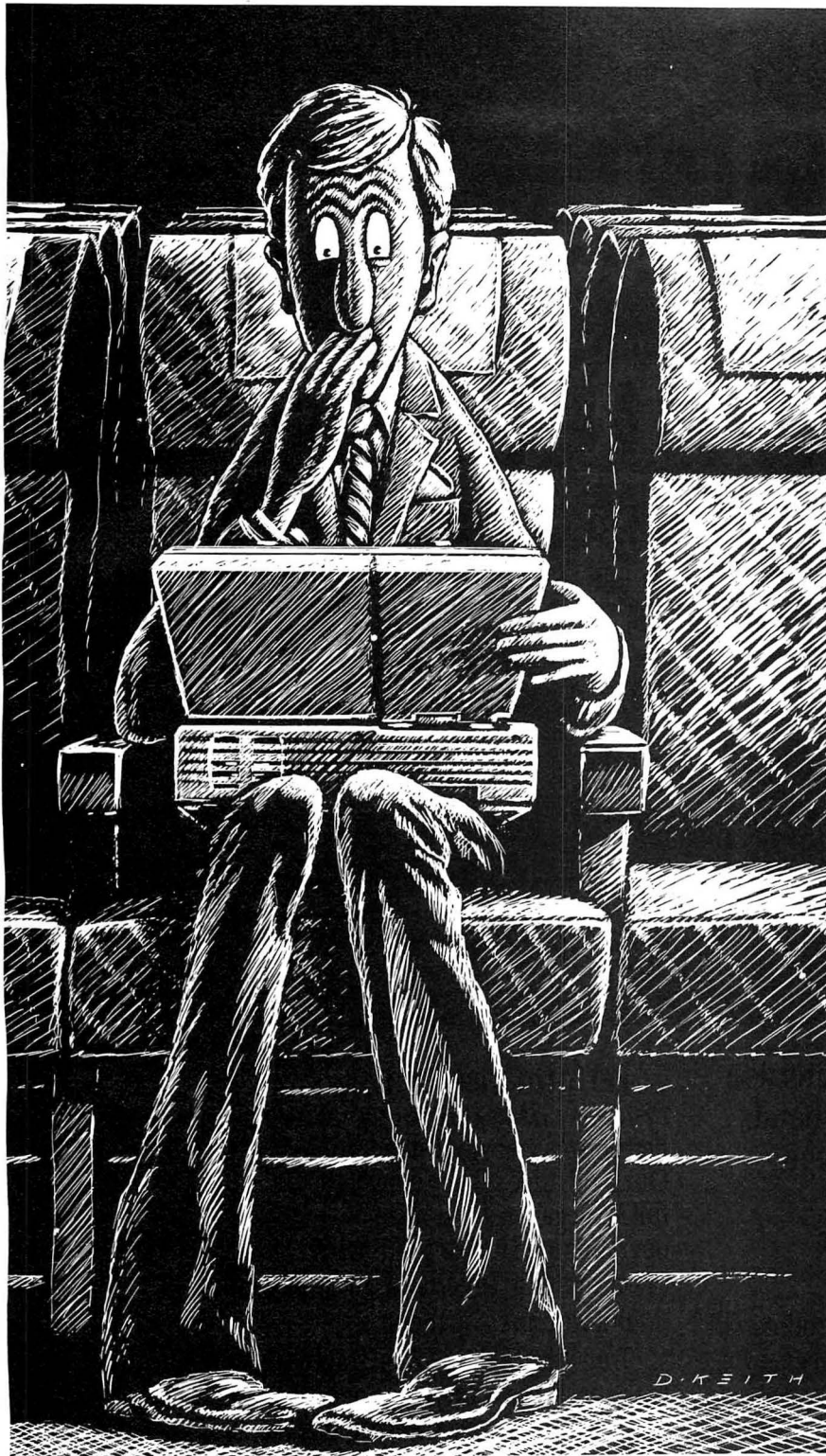

There you are sitting happily with your laptop in the sky, preparing some figures for an important meeting at the airport. Then, without warning, your screen flickers and goes dark. Your laptop just died.

Things could be better. If you'd been using Battery Watch you would have been prepared.

Battery Watch operates like a fuel gauge for your laptop. Its pop-up window lets you see what's left of your battery power in hours and minutes.

It'll also help you get more out of those sneaky NiCad batteries. The Deep Discharge feature makes sure of it. It eliminates the nagging "charge memory effect" of NiCad batteries and ensures their original peak performance.

Battery Watch has taken the worry out of something else, too. Compatibility. It's compatible with all popular laptops from Amstrad to Zenith.

And at \$39.95, it's the cheapest insurance around.

Look for it at your local computer store. Or call 1-800-343-8080 for a free laptop accessory catalog. In Washington call (206) 483-8088.

Traveling  Software

18702 North Creek Parkway Bothell, WA 98011

Without Battery Watch, You Could Be At 40,000 Feet And Out Of Fuel.

HeadStart III™

One System for all the right reasons.

At Vendex we design every computer as a complete system. We integrate peripherals usually offered only as options. All you have to add is electricity. So your HeadStart III™ is productive from the moment you open the box.



5 1/4" and 3 1/2" Diskdrive
Both Standard

Convenience. The HeadStart III™ incorporates both a 1.2 megabyte 5.25-inch and a 1.44 megabyte 3.5-inch floppy drive, both standard, so you don't have to choose between the two. Our "bridge technology" lets you boot a disk from either drive and software

select your drive configuration.

In addition, the low profile and small footprint of the HeadStart III™ make it ideal for even the smallest workstation.

Performance. The heart of the HeadStart system is a 12MHz 80286 processor with a hefty one megabyte of standard RAM. Our hard drive system delivers a full 32 megabytes of storage operating at 28 milliseconds with astonishing 1 to 1 interleave and a 32K buffer.



But we don't stop there.

True 16 bit built-in VGA Graphics is component matched for high speed and clarity. Even our 101-key PS/2 type keyboard has been tailored for speed and durability.

Flexibility. Virtually any combination of peripherals can be attached without ever opening the computer. Two serial ports, one parallel port, a bus mouse port and even a game port are all standard.

Expandability. The HeadStart III™ is engineered for your future applications. It has been designed to give you 3 empty full-sized expansion slots for networking or accommodating the many diverse peripherals that are available today and tomorrow.

In fact, the HeadStart III™ is truly OS/2 ready. You can add two full megabytes of RAM without having to buy any additional boards.



For more information about the HeadStart III™ and our full line of advanced computer systems, or to find the nearest dealer, call toll-free **1-800-882-1888**. Can you think of a reason not to?

Value. Going beyond DOS which is of course standard, an unprecedented package of 14 name brand programs worth thousands of dollars are included FREE with your HeadStart III™.

Support. Our P.C. COACH, nationwide toll-free hotline is available free to registered owners.



SPECIFICATIONS

MICROPROCESSOR: Intel 80286-12
 SPEED: 12MHz/8 Switchable
 BIOS: Award
 BUILT IN RAM: 1 Megabyte
 EXPANDABLE TO: 3 megabytes
 POWER SUPPLY: 145 watts 110/220 switchable
 KEYBOARD: 101 key PS/2 compatible
 GRAPHICS: VGA Autocync
 FLOPPY DRIVES: one 5.25" 1.2 megabyte, one 3.5" 1.44 megabyte

HARD DRIVE: 32.1 megabyte, 28 milliseconds, 1:1 interleave
 BUILT IN INTERFACES: Parallel, 2-RS232 serial, mouse, joystick
 EXPANSION SLOTS: 3 available
 MOUSE: Standard
 SOFTWARE: DOS 3.3, GW Basic, HeadStart Advanced Environment, Floppy Driver, Framework II, 3-D Graphics, ATT and Computer-EEZ Tutorial Software, Xtree hard disk manager, Publish-it!, Chessmaster 2000, Splash VGA paint program, Bookmark, plus Twist and Shout.

HEADSTART ADVANCED OPERATING ENVIRONMENT is a trademark of VenDEX Technologies, Inc. IBM is a trademark of International Business Machines Corp. MS DOS 3.3 and G/W BASIC are trademarks of Microsoft, Inc. FRAMEWORK II is a trademark of Ashton-Tate. 3-D GRAPHIS is a trademark of Perspective. FLOPPY DRIVER is a trademark of Concept Technologies. X-TREE is a trademark of Executive Systems Inc. SPLASH! is a trademark of Spinnake Software Corporation. COMPUTER-EASE is a trademark of Arrakis Technologies. CHESSMASTER 2000, MAVIS BEACON TEACHES TYPING and TWIST & SHOUT are trademarks of Software Toolworks, Inc. HOW TO USE YOUR PC is a trademark of American Training International. BOOKMARK is a trademark of Intellisoft International. PUBLISH-IT is a trademark of Timeworks, Inc. ©1988 VenDEX Technologies, Inc. All Rights Reserved. VENDEX TECHNOLOGIES, INC. 40 Cutter Mill Road, Suite 438, Great Neck, New York 11021.

VENDEX®
HEADSTART™ III
 Built to be compatible with you.™

QUICK ACCESS EASY EDIT



THE MATCHMAKER
GOLDEN BOW SYSTEMS

TM

A MATCH FOR YOUR FILES—find disk information fast, no matter how it's formatted. No need to index or keyword your files—just describe what you want in plain English or regular expressions, and it's on your screen *fast*.

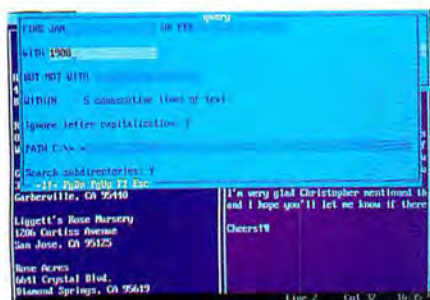

The query panel is Vq's window into your disks.

A MATCH FOR YOUR PATH—quickly search a file, a whole disk, or anything in between to find all the files with a match to your search pattern, then display each match in full context!

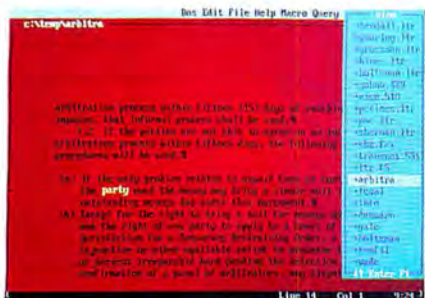

After a query, Vq lists the files containing the target pattern and displays the matching text, highlighted in context.

WHEN YOU FIND IT, USE IT with Vq's full-featured editor or your own word processor, compiler, or custom macro.

A MATCH FOR YOUR CREATIVITY—expand your creativity into a screenful of windows for different files or different parts of a file. Zoom them, compare them, edit them in parallel, or copy-and-paste to a new file.

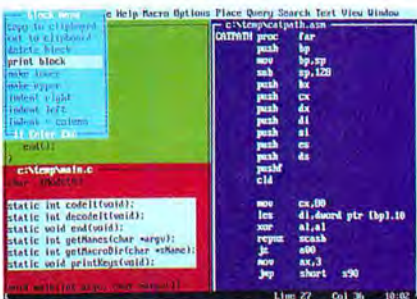

Vq's Block command menu is pulled down for processing the marked block of text.

A MATCH FOR YOUR STYLE—everything you want for creating and manipulating text, plus a few things you never thought to ask for—paragraph formatting, text centering, auto-indent, search-and-replace, copy, cut, delete or print blocks—*effortlessly!*

A MATCH FOR YOUR DISPLAY—25, 43, or 50 line display modes, and you pick the screen colors!

A MATCH FOR YOUR MOUSE—full mouse support with pull-down command menus means you don't have to remember *anything*. All Vq's power is delightfully accessible—just point and shoot!

A MATCH FOR SYSTEM FAULTS—while you're working, *auto-save* is working too, so you can automatically start each session where the last one ended—even if it ended *unexpectedly!*

A MATCH FOR YOUR APPLICATIONS—add Vq's access and editing talents to the applications you know and love.

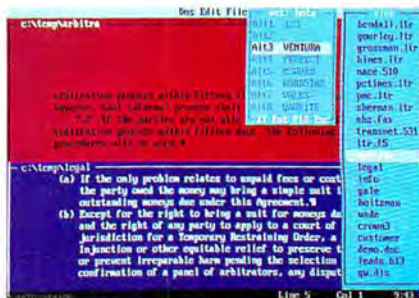

The small-pull-down menu lists Vq's preconfigured Hot Links to other applications.

Vq comes with Hot Links to popular applications, and creating more is a snap. Pass your desktop publisher the file you created, format it, print it, then return to Vq to find your sales summary and jump-start your spreadsheet program, or write brilliant code and Compile-and-display-next-error. Vq shrinks to just 7K bytes during linkage and gives your applications room to run!

A MATCH FOR YOUR CHORES—teach Vq whatever you do over and over. Vq's macros learn any input sequence for flawless playback at your command, for infinite customization!

Vq operates with OS/2 or DOS 3.0 or higher in IBM-compatible systems with 256K bytes.

Vq is a trademark of Golden Bow Systems

SEE YOUR DEALER OR CALL TOLL-FREE

(800) 284-3269

GOLDEN BOW SYSTEMS

2870 5th Avenue
San Diego, CA 92103

FAX (619) 298-9950

(619) 298-9349

TELEX 201520 GBS UR

\$270

M/C VISA
\$5 US shipping
CA orders add 7%



BOOK REVIEWS

No Way: The Nature of the Impossible

Edited by Philip J. Davis and David Park

W. H. Freeman and Co.,
New York: 1987, 325 pages,
\$10.95

Reviewed by David A. Mindell

It is impossible to climb Mt. Everest without oxygen. It is impossible to make music at a rate greater than 10,000 bits per second. It is impossible to create a stable, strained-layer superlattice.

These statements refer to achievements that were once considered beyond the practical, physical, or conceptual boundaries of possibility. To those who pronounced them or accepted them as being true, such statements defined the limits of our "real" and logical world.

Each statement, however, has since been proved wrong. In 1979, Reinhold Messner and Peter Habeler climbed Everest without oxygen. Modern electronic synthesizers create music (or at least sound) with more information content than that of a symphony orchestra. Scientists have fabricated strained-layer superlattices in the laboratory. Thus, we have expanded what we define as the possible; we have made inroads into the dark region of impossibility, pushing back the once-solid walls of the unreal.

No Way: The Nature of the Impossible, edited by Philip J. Davis and David Park, is a collection of essays by prominent authors in widely varying fields. Each writer engages impossibility with language and methods specific to his or her own specialty. The result is a fascinating and thorough dialogue about a concept that

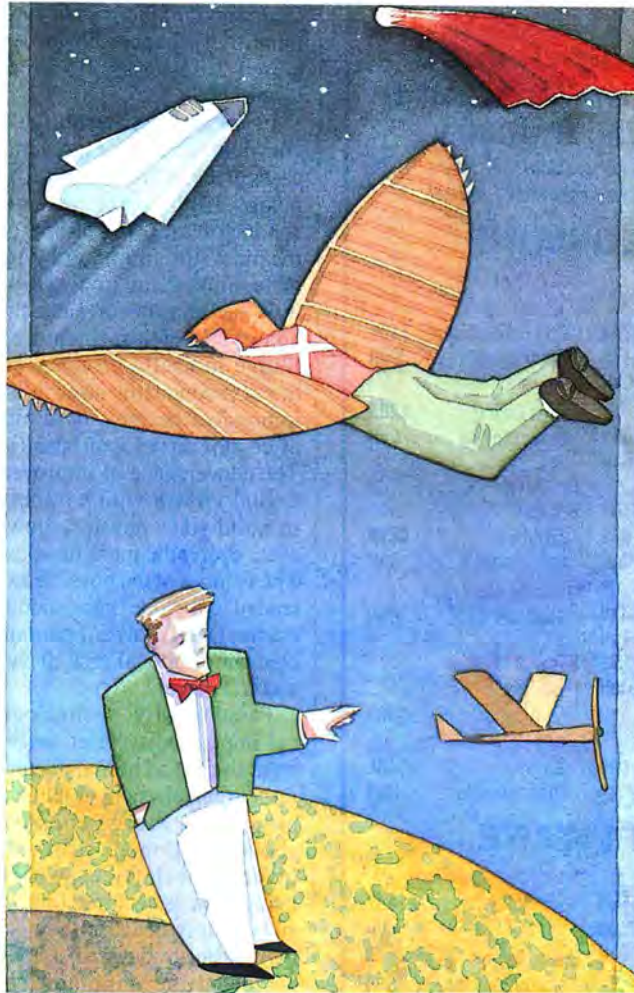

transcends, limits, and even defines endeavors including mountain climbing, medicine, technology, parenting, and artificial intelligence.

The book begins with a chapter entitled "Everest and the Impossible" by Scott Lankford, a climber and a vet-

eran of a failed 1985 attempt on the mountain. Lankford recalls the sense of melancholy that accompanied the triumph of Everest's first ascent, for it seemed the last great earthly obstacle, the last of nature's impossibilities. The instant Edmund Hillary and Tensing

Norgay mounted the summit in 1953, Everest entered the realm of the possible. The mountain was not conquered, however, for at that same instant arose new impossibilities: Everest without oxygen, Everest alone, Everest "the hard way." As Lankford says, "Climbers don't conquer the impossible, they invent it."

Lankford's essay sets the tone of the book; the mountain is a particularly apt model for the impossible. The base is accessible, but the peak is not. The edge of the possible thus lies somewhere in between, graded on the gradual slope. Lankford describes his own encounter with this boundary when, with the realization that he and his party could not reach the summit, "The door to the invisible became visible, like the summit of Everest itself suddenly torn from the clouds." The impossible is not always a wall or a cliff, but more often is like the slope of a mountain. This feature, of progressive, almost exponential steepness, lets us approach and even drive back the impossible while never overcoming it.

In another essay, Michael J. Katz asserts that *evolution* of any organism would be possible were it not for the limits of the physical world. "Hedgehogs that run faster than the speed of light," for example, could evolve if they were physically possible.

Michael Yarmolinsky takes a similar approach but delves more into the limits of the evolutionary process. He impressively relates evolution to what he calls the "central dogma" of molecular biology, namely Francis Crick's generalization that information can flow only from DNA to RNA into proteins and *not* the other way (i.e., "protein cannot serve as

continued

ALSO REVIEWED

Programmer's Guide to OS/2

Peopleware: Productive Projects and Teams

Better Scientific and Technical Writing

C Traps and Pitfalls

What Do You Care What Other People Think?

ORDER LINE 1-800-528-1054



Unbeatable Prices

The Acknowledged Leader in the Computer Mail Order Industry
 Call About the Availability of Other Products Not Listed.

HARDWARE

PRINTERS:		CARDS:	
Epson		Paradise	
LQ500	\$289	VGA Professional	\$469
LX800	175	Other Models	Call
Other Models	Call	Video 7	
NEC		Vega Deluxe	\$205
P2200	\$349	Other Models	Call
Other Models	Call		
Okidata		MODEMS:	
320	\$309	Hayes	
391	609	1200B	\$279
Other Models	Call	Other Models	Call
Panasonic		US Robotics	
1124	\$319	All Models	Call
KXP1080I	160		
KXP1091I	179	MONITORS:	
Other Models	Call	NEC	
DRIVES:		Multisync II	\$589
Toshiba		Princeton Graphics	
3 1/2 (1.4MB)	\$99	Ultrasync	\$485
3 1/2 (720K)	89	Other Models	Call

SOFTWARE

Boreland		Paperback Software	
Turbo Pascal	\$93	VP Planner	\$47
Turbo Prolog	93	Other Titles	Call
Other Titles	Call	Peter Norton	
Central Point		Norton Advanced	\$69
Copy II		Norton Utilities	47
Option Board	\$99	Other Titles	Call
Other Titles	Call	PFS	
Dac		First Publisher	\$69
Dac Accounting	\$53	Professional Write	102
Other Titles	Call	Other Titles	Call
Lotus		Word Perfect	
Lotus 1, 2, 3	\$285	Word Perfect 5.0	\$219
Other Titles	Call	Other Titles	Call
Microsoft		Xerox	
C Compiler	\$269	Ventura	
Macro Assembler	89	Publishing	\$465
Windows 286	59	Other Titles	Call
Other Titles	Call		

VISA **MasterCard**

MMG MICROCOMPUTER MARKETING COUNCIL

No Charge for VISA and Mastercard. We Do Not Charge Your Card Until Your Order is Shipped. All products including D.O.A.'s, carry our manufacturer's warranties. We do not honor guarantees, rebates, trial period privileges or promotional programs offered by manufacturers. You Pay The Ground Shipping 1-10# \$6.00; 11-20# \$10.00 (Except Alaska & Hawaii). We Pay The Air Difference. Free Air Applies ONLY to Orders Over \$100.

No APO, FPO, or international orders please.
 Call Before Submitting P.O.'s. Ask for National Accounts.
 Personal and Company Checks Will Delay Shipping 3 Weeks.
 Prices, Terms & Availability Subject to Change Without Notice.
 Add 5% for C.O.D. Orders.
 We Do Not Guarantee Machine Compatibility.
 Mailing Address: TELEMART, 8804 N. 23rd Ave., Phoenix, AZ 85021.
 To Place an Order: 1-800-528-1054.
 To Follow Up On An Order: (602) 944-1037.
 Order Line Hours: Mon.-Fri. 7:00 am-6:00 pm, Saturday 9:00 a.m.-1:00 p.m.
 Order Processing: (602) 944-1037, 10:00 a.m.-3:00 p.m. Mon.-Fri.

Circle 229 for MS DOS Products. (All others: 230)

BOOK REVIEWS

a template for its own replication"). Thus, the reader arrives at Charles Darwin's famous break from earlier (Lamarckian) theories of evolution: "It is impossible for acquired characteristics to direct evolution."

Physicist Michael Sturge's contribution explores several cases of the impossible in technology. He discusses the semiconductor laser, an example of the most straightforward type of technological impossibility—the limits of current technology. Skeptics (including Sturge himself) pronounced the semiconductor laser to be impossible because of limits of crystal purity and opacity. The convergence of improved crystal growth with advances in solid-state physics, however, overcame these hurdles. The frontier of the possible extended to include the semiconductor laser, now a common element of optical disk drives and CD players.

Paradoxically, technological impossibility often arises from social and human factors rather than physical or natural properties. Sturge cites the above-mentioned strained-layer superlattice, which many experts declared impossible simply because they got their basic physics wrong; they neglected the minimum energy required to produce a damaging dislocation. Sturge also discusses the failure of Bell Labs to pursue research into large-scale ICs. Apparently the organizational and management structure could not admit certain kinds of change (the infamous Not Invented Here syndrome). In that sense, what is possible in today's technological world is what our socially determined institutions can develop and exploit: weapons, commercial products, medical instruments, and so on. A new technological development might not fit neatly into such categories or might not lend itself to the methods modern society has evolved for capitalizing on innovation. Such a technology might find itself confined to a

narrower possibility and to more imposing impossibilities than one that lies within traditional political, industrial, and financial flows.

The scientific and technical chapters of *No Way* have a common element: the exponential mountainside of impossibility. Some statements are clearly impossible and always will be: "You can't put a thousand gallons of water into a pint bottle." These are scientifically uninteresting, for they arise out of definitions, language, and logic, and will yield little when examined. In contrast, the impossibilities that define the limits of our knowledge are truly engaging: "There is no cure for AIDS." These problems are constantly revealing, shifting, and, we hope, receding; they occupy and define the borderlines of possibility. In David Park's words, "... that narrow strip, on either side of the border, is where science lies."

No Way is not all about science, however. It also covers law, politics, economics, education, poetry, music, and philosophy. Through the common theme, the authors introduce the reader to a broad range of discourses and the specific languages with which they operate. Furthermore, because the "impossible" is by its nature an abstract and even absent topic, the reader sees each discipline defined as a shadow, groping in the dark for the unreachable. He or she is left with a lasting impression of the academic disciplines, disparate in their language, yet converging in their attempts to know the unknowable.

BRIEFLY NOTED

Programmer's Guide to OS/2 by Michael J. Young, Sybex, San Francisco, CA: 1988, 625 pages, \$24.95. If the complexity of a software product were measured by the number and size of the books written about it, there could be

continued

VAX Power - PC Price!

If you need or are accustomed to the throughput of a 32-bit mini, including any of DEC's VAX series, MicroWay has great news for you. The combination of our NDP compilers and our mW1167 numeric coprocessor gives VAX speed to your 386 PC! If you don't own a 386 PC, we provide a number of powerful PC and AT upgrade paths.

MicroWay offers transputer based parallel processing boards and languages for the PC, AT, or 386. Each T800 RISC processor on these boards packs the power of a 20 MHz 386/1167. A Quadputer, with four T800s, boasts 40MIPS/6 megaflops of throughput.

Many NDP Fortran-386 users are reporting turnaround times that are two to six times faster than their VAX. They are a function of the VAX processor being used, the speed of the 386, the number of users served by the VAX, and the coprocessor being used with the 386.

Dr. Robert Atwell, leading defense scientist, calculates that NDP Fortran-386 is saving him \$12,000 per month in rentals of VAX hardware and software while doubling his productivity!

Fred Ziegler of AspenTech in Cambridge, Mass. reports, "I ported 900,000 lines of Fortran source in two weeks without a single problem!" AspenTech's Chemical Modeling System is in use on mainframes worldwide and is probably the largest application to ever run on an Intel processor.

Dr. Jerry Ginsberg of Georgia Tech reports, "My problems run a factor of six faster using NDP Fortran-386 on an mW1167 equipped 386/20 than they do on my MicroVAX II."

Our NDP compilers and NDP utilities are the key to taking advantage of the two to five-fold increase in speed that the mW1167 provides. The compilers generate mainframe style code, while our utilities simplify ports from either the PC or the mainframe world. A new utility enables our NDP compilers to call HALO 88.

If you are curious about the benefits of the NDP/mW1167 approach, consider the following (price estimates are for complete systems):

Coprocessor	Speed (Flops)	Price
80287-10	80,000	\$3,000
80387-20	440,000	\$5,000
mW1167-20	2,100,000	\$6,000

When driven by a 32-bit compiler, the mW1167 approaches the speed of a \$600,000 VAX 8650! In fact, many of our users have reported increases in turnaround of 2 to 4 times that of their VAX! Call us for complete details.

32-Bit Compilers and Tools

NDP Fortran-386™ and NDP C-386™ Compilers generate globally optimized, mainframe quality code. Both run in 386 protected mode under Phar Lap extended MS-DOS, UNIX, or XENIX. The memory model employed uses 2 segments, each of which can be up to 4 gigabytes. They generate code for the 80287, 80387, or mW1167. Both include high speed EGA graphics extensions written in C that perform BASIC-like screen operations.

- **NDP Fortran-386™** Full implementation of FORTRAN-77 with Berkeley 4.2, VAX/VMS and Fortran-66 extensions. \$595
- **NDP C-386™** Full implementation of AT&T's PCC with MS and ANSI extensions. . . . \$595

NDP Package Pricing:

387FastPAK: NDP Compiler, Phar Lap and 80387 Coprocessor
16 MHz: \$1299
20 MHz: \$1499

1167FastPAK: NDP Compiler, Phar Lap and mW1167 Coprocessor
16 MHz: \$1695
20 MHz: \$2295

Phar Lap Development Tools \$495
Virtual Memory Extension \$295

NDP Windows™ — NDP Windows includes 80 functions that let you create, store, and recall menus and windows. It works with NDP C-386 and drives all the popular graphics adapters: Library: \$125, C Source: \$250

NDP Plot™ — Calcomp compatible plot package that is callable from NDP Fortran. It includes drivers for the most popular plotters and printers and works with CGA, Hercules, EGA and VGA \$325

NDP/FFT™ — Includes 40 fast running, hand coded algorithms for single and double dimensioned FFTs which take advantage of the 32-bit addressing of the 386 or your hard disk. Callable from NDP Fortran with mW1167 and 80387 support \$250
387FFT for 16-bit compilers \$250

HALO 88 to NDP Graphics Interface — This module enables you to call graphics routines in HALO 88 from NDP Fortran or C \$100

MicroWay® 80386 Support (508) 746-7341

Parallel Processing

Monoputer 2™

The world's most popular PC transputer development product now extends the memory available for developing transputer applications from 2 to 16 megabytes. The board now features a DMA bus interface for fast I/O. Monoputer 2, an ideal platform for porting mainframe Fortran or C code, provides the speed of a 386/20 for 20% of the cost!

Monoputer 2 with T414 (0 MB) \$995
Monoputer 2 with T800 (0 MB) \$1495

Quadputer™

This board for the XT, AT, or 386 can be purchased with 2, 3 or 4 transputers and 1, 4 or 8 megabytes of memory per transputer. Two or more Quadputers can be linked together to build networks with mainframe power which use up to 100 or more transputers. One customer's application has gone from 8 hours on a mainframe to 16 minutes on a system containing five Quadputers from \$3495

Transputer Compilers and Applications

MicroWay offers Parallel languages for the Monoputer and Quadputer.

Logical Systems Parallel C \$595

MicroWay Occam2 \$495

3L Parallel C \$895

3L Parallel Fortran \$895

MicroWay Prolog Interpreter \$750

Microfield - Finite element analysis . . \$1600

ParaSoft: Parallel Environment . . . \$300

Performance Monitor \$200

C Source Level Debugger \$300

T800/NAG™ (See NDP/NAG) \$2750

387BASIC™ — Our 16-bit MS compatible compiler introduces numeric register variables to produce the fastest running 80x87 code on the market \$249

Compaq 386/20/25 Add-Ons

RAMpak™ — One megabyte 32-bit memory module fits in Compaq memory slot . . . CALL mW1167™ is built at MicroWay using Weitek components and includes an 80387 socket.

mW1167-16 \$995
mW1167-20 \$1595
mW1167 Microchannel-16 \$1295
mW1167 Microchannel-20 \$1595
Weitek 3167-25 \$2495
80387-20 \$595
80387-25 \$695

Numeric Coprocessors

8087 \$99
8087-2 \$145
80287-8 \$239
80287-10 \$279
80387-16 \$425
80387-16SX \$450
80387-20 \$595
80387-25 \$695
287Turbo-12 (for AT compatibles) . . . \$450
256K 100ns DRAM \$13
256K SIMMS \$119
1 MB SIMMS \$450
(All of our Intel coprocessors include 87Test.)

Intelligent Serial Controllers

MicroWay's **AT4™**, **AT8™**, and **AT16™**, the fastest intelligent serial controllers, run in AT, 80386 and PS/2 PCs. They come with drivers for UNIX, XENIX, and PC MOS.

AT4 ... \$795 **AT8** ... \$995 **AT16** ... \$1295

32-Bit Applications

PSTAT-386 — Popular mainframe statistics package. The full version was ported . . . \$1495

NDP/NAG™ — Features a library of 268 engineering and scientific numerical algorithms. Callable from NDP or 3L Fortran \$895

12 MHz PC Accelerators

FastCACHE-286 12 MHz \$299
SuperCACHE-286 12 MHz \$399
FastCACHE-286 9 MHz \$199

MicroWay

World Leader in PC Numerics

P.O. Box 79, Kingston, MA 02364 USA (508) 746-7341
32 High St., Kingston-Upon-Thames, U.K., 01-541-5466
USA FAX 617-934-2414 Australia 02-439-8400 Germany 069-75-1428



\$95 2400 BAUD MODEM

30 DAY FREE TRIAL !

SUPERIOR PERFORMANCE is the reason to buy this modem, not its low cost !!! Most low cost 2400 baud modems are error prone or have other faults. Not ours, they will outperform the most expensive modems costing several hundred dollars. DYNAMIC IMPEDANCE STABILIZATION, DIS, invented by CompuCom automatically compensates for real-world phone line impedance variations. It improves signal quality and reduces errors (due to noise and poor telephone circuits) up to 95%. This is not simply an error correction scheme nor is it marketing hype. Our modems are truly superior. We can prove it! The CCC 2400 is a \$95 high performance Hayes-compatible IBM internal half card. It will outperform the alternatives. In combination with DIS (\$24 option) it will outperform the challengers, regardless of cost. Made in USA • five year warranty internal speaker • software included • dealers inquire... **If you aren't totally satisfied, you may return it within 30 days for a full refund.**

1275 PALAMOS AV call for details SUNNYVALE CA

(800) 228-6648 CompuCom Corporation (408) 732-4500



MR. BOOKS[®]

asks:

"Did your best friend run off with your wife and your software manuals? And you miss your manuals?" Well, we can help, as we stock the industry's best computer books, and at great discounts!

SAVE UP TO 40% OFF!

No.	BOOK TITLE	PUB	# OF PAGES	OF QUAL	DISC GRD	PRICE
7266	Build Your Own 80286 IBM Compatible	TAB	208	**		15.93
6090	C Primer Plus, Revised Ed	SAM	576	**	B/I	21.46
2519	Compl. Hypercard Hndbk 2nd ed	BAN	720	**	I	25.06
5008	Customizing AutoCAD	NRD	560	**	I/A	30.06
5240	dBase III+ Handbook, 2nd Ed	QUE	519	**	I	17.16
7903	Desktop Publish' w/PageMaker	WLY	289	**	I	17.16
5002	Inside AutoCAD	NRD	576	**	I	30.06
4300	Inside OS/2	MS	685	**	I/A	17.16
7107	Lotus 1-2-3 Desktop Companion	SYB	976	**	I	19.74
7112	Mastering AutoCAD, 2nd Ed	SYB	739	**	I	25.76
7114	Mastering Crosstalk XVI	SYB	187	**		14.58
6601	Mastering First Choice	SF	301	**	B	17.24
7012	Mastering Quattro	SYB	576	**		19.32
7023	Mastering Ventura	SYB	547	**	I	19.74
7007	Mastering WordPerfect 5.0	SYB	708	**		18.88
7031	MS-DOS Power User's Gd 2nd Ed	SYB	576	**	I/A	17.16
5255	Norton's Prgrmr's Gd to PC&PS/2MS		511	**		19.74
4249	Prgrmr's Gd to PC&PS/2 video sysMS		544	**	I/A	20.20
4230	Proficient C	MS	512	**	I/A	20.20
2306	Programming in Clipper, 2nd Ed	AW	728	**		28.32
4279	Programming Windows	MS	852	**	A	21.46
4242	Running MS-DOS, 3rd Ed	MS	512	**	I	18.59
7053	Understanding dBASE III Plus	SYB	425	**	I	17.78
5282	Using 1-2-3, Special Edition	QUE	905	**	I	20.21
5288	Using Enable, 2nd Ed.	QUE	750	**		19.74
5222	Using WordPerfect, 5.0	QUE	876	**	B/I	18.88
5208	Using WordStar, ver 5.0	QUE	535	**	I	16.30

* GOOD B BEGINNER SHIPPING & HANDLING
** VERY GOOD I INTERMEDIATE \$1.60 - 1 BOOK
*** EXCELLENT A ADVANCED \$1.00 EACH ADD'L BOOK

Call for our 'Catalog on a Disk' of approximately 2,000 of the best computer books, by the best authors in the industry. With mini-reviews of selected titles \$2.50 for shipping & handling.

ORDERS ONLY: 1-800-274-1460: ORDERS ONLY
Questions/Title Searches/Inquiries Call 303-984-2315
MR. BOOKS, INC., 400 N. 7th, New Castle, CO 81647

BOOK REVIEWS

no doubt that OS/2 is a complicated beast. The first few books written about it seemed to be almost extensions—both in style and bulk—of the OS/2 specification and the documentation shipped with its early versions.

Michael J. Young's new book exhibits a maturity in its presentation that earlier books have lacked. He speaks with the authority that comes from having done some serious OS/2 programming. Instead of just stating the purpose of an OS/2 function call, Young actually describes how it might be used in real code. For example, instead of stating that `DosQHandType` determines if standard output has been redirected to a file, he describes a situation in which you might need to discover if a child process's output is redirected by its parent process to a disk file so the parent can continue to write to the screen without interference from the child. The description goes on to warn that using `DosWrite` is better than a similar video I/O call because `DosWrite`'s output can be redirected, while VIO calls always write to the screen. These subtle insights can be useful.

The book also offers a fair amount of code, most of it in C, not assembly language. Some of the code is long and complex, like the cut-and-paste utility that spans 11½ pages. A companion disk contains all the listings, including header, make, and definition files.

Of the book's 625 pages, 250 pages are appendixes devoted to summarizing API calls and error messages. But the preceding 375 pages contain a lot of practical advice for the aspiring OS/2 programmer.—G. Michael Vose

Peopleware: Productive Projects and Teams by Tom DeMarco and Timothy Lister, Dorset House Publishing Co., New York: 1987, 188 pages, \$23. *Peopleware* is the *Mythical Man-Month* for the 1990s. Just as Fred Brooks was emi-

nently qualified to write his book on software-project management, Tom DeMarco and Timothy Lister, internationally known software consultants, are similarly qualified to write about productive teams. DeMarco's *Structured Analysis and System Specification* is a classic in the field of information management.

Peopleware is a collection of essays about teams, productivity, and quality. The authors' style is casual, and they sprinkle their essays with anecdotal insights. But don't be misled by the informal style into expecting a hodgepodge of software folklore and rule-of-thumb management quips. The information presented is based on years of observing development efforts, surveys, and the authors' annual Coding War Games.

The book is divided into five parts. In the first section, "Managing the Human Resource," DeMarco and Lister advise against treating people as faceless modular resources. Instead, they recommend that managers seek to motivate their teams with the goal of producing good products in a sane environment. The underlying thesis of this section is that most of the problems occurring in high-tech projects are not technological but sociological.

The largest single section of the book is devoted to the office environment. This section is an indictment of the open-office concept that has swept through corporate America. It shows the fallacy in the cost-benefit analysis that says, "We can put a hundred people on this floor, and just look at all the money we save." An open office, the authors maintain, guarantees continuous interruption. No studies support the open office, while several (by IBM, ITT, and others) show that it has a deleterious effect on knowledge workers.

The authors give a simple formula for managing teams: Get the best people (cut out the

continued



While dBASE Promises You The Moon, Clipper Delivers.

Right now, while others dream about the database of the future, you can be using it today to create applications of unparalleled sophistication. With Clipper® — the most powerful and complete database development system for PCs.

Open the Clipper box and you'll find the enhancements dBASE® has been promising. And some it hasn't.

Such as: a remarkable development language that takes you way beyond dBASE® emulation, with enhanced commands and entirely new language extensions. A unique open architecture which gives you the flexibility to create and easily integrate user-defined functions in C, Assembler, Clipper, and still other languages. The speediest-ever dBASE compiler, yielding applications up to 20 times faster. And that's just for starters.

Clipper also provides the most capable menu-driven debugger to be found anywhere, as well as half a dozen modifiable utilities to further reduce development time.

There's source code security, too, plus sophisticated record and file-locking capabilities that make networking

	Clipper® \$695*	dBASE III PLUS™ \$695*	dBASE IV™ Developers Ed. \$1295*
A true compiler	Yes (1984)	No	???
User-defined functions	Yes (1984)	No	Limited
Arrays	Yes (1985)	No	Just Intro'd
VALID function	Yes (1985)	No	Just Intro'd
Improved Execution Speed	Yes (1984)	No	No
Link in Other Languages	Yes (1984)	No	Limited
Null Character Support	Yes (1987)	No	No

*Suggested retail price

applications easier to create.

And once you have created them, Clipper gives you an equal measure of control over distribution by creating .EXE files — there are no runtime modules, licensing or royalty fees, or additional software requirements. You can even add stations to a network without adding to your costs.

All of which adds up to the most powerful and flexible database

development system today.

Why settle for the moon when you can reach for the stars? Call (213) 390-7923 today, and we'll send you a free demo diskette and a very informative booklet, *Developing and Compiling in Clipper*. The dBASE development system that's not just one small step...but a giant leap forward in programming power.

Clipper®

Nantucket Corp., 12555 W. Jefferson Blvd., Los Angeles, CA 90066
 Telex: 650-2574125 Fax: 213-397-5469

Copyright © Nantucket Corporation, 1988. All rights reserved.
 Nantucket and Clipper are registered trademarks of Nantucket Corporation. dBASE is a registered trademark and dBASE III PLUS and dBASE IV are trademarks of Ashton-Tate Corporation.

**WANG
MICROSYSTEMS
LOOKS AT YOU
DIFFERENTLY.
OUR PCs PROVE IT.**

**CALL WANG MICROSYSTEMS DIRECTLY
AND FIND OUT ABOUT THE NEW
WANG 380 SERIES.**

WANG

Microsystems

Your Account Representative's Name

**WANG MICROSYSTEMS
1-800-962-4727**

1231A

We designed the Wang 380 series with all the features you'd expect from a great microsystem—speed, flexibility and computing power—but we've added one feature no other computer on the market today offers. Call your Wang Account Representative 1-800-962-4727 for more information.

SPECIFICATIONS:

Wang Microsystems PC381 and PC382*

- Intel 80386 microprocessor running at 16MHz for the PC381, and at 20MHz for the PC382
- 1.2MB or 1.44MB diskette drive
- 1MB, 2MB, or 4MB of base memory expandable to 16MB (utilizing the standard dedicated 32 bit high speed expansion slot)
- 32 bit paged/interleaved memory controller card
- 8 industry standard expansion slots (two 8 bit, six 16 bit)
- Two serial and one parallel port
- Choice of keyboards (12 function key IBM enhanced compatible or 16 function key Wang/IBM enhanced compatible)
- 229 Watt power supply

Four hard disk drive options

- 42MB 23ms
- 68MB 28ms
- 143MB 23ms ESDI
- 321MB 18ms ESDI

Partial listing of Wang PC options

- Additional 3.5" 1.44MB Diskette Drive.
- Additional 5.25" 360KB or 1.2MB Diskette Drives.
- Intel 80387 math coprocessor (16MHz or 20MHz).
- 100 nanosecond 1MB, or 256KB memory SIMM Modules.
- VGA analog monochrome or color monitor.
- VGA color plus controller.

WANG

Microsystems

1-800-962-4727

***ASK ABOUT THE OTHER MODELS AVAILABLE IN OUR COMPLETE FAMILY OF PCs.**

**CALL
WANG MICROSYSTEMS
DIRECTLY
ABOUT THE NEW
380 SERIES,
AT 1-800-962-4727**

We've designed our PC's with all the features you'd expect from a great microsystem — speed, flexibility and computing power—but we've added one feature no other computer on the market today offers.

The Wang Microsystems Account Representative.

From your very first inquiry, you'll be speaking with a Wang-trained expert. Someone who can answer all your questions quickly and efficiently. Someone who knows the right questions to ask you. Someone who knows our products inside and



out, who won't put you on hold while fumbling with spec sheets and manuals. In short, an expert who will deal with you on a professional level.

We encourage you to call 1-800-962-4727 for a sample of the kind of service you can expect. Ask your account

representative your toughest questions. Find out how a Model 381 or 382 fits in with your current equipment. What improvements in productivity you can expect. Ask about technical support. And what happens when a newer technology is developed.

Your Wang Microsystems account representative can help tailor a system to your needs and your current equipment.

Help you get up and running without delays. Show you how to make the most of the computer's superior technology. And provide on-line technical assistance every working day.

Because when you purchase a Wang Microsystems PC, you're buying more than a computer. You're buying membership in an information and service network that will stand behind you.

To discover for yourself what our more direct approach can do for you, call one of our Account Representatives at 1-800-962-4727 today. You'll get a whole new perspective on buying a computer.

SPECIFICATIONS: Wang Microsystems PC381 and PC382*

- Intel 80386 microprocessor running at 16MHz for the PC381, and at 20MHz for the PC382
- 1.2MB or 1.44MB diskette drive
- 1MB, 2MB, or 4MB of base memory expandable to 16MB (utilizing the standard dedicated 32 bit high speed expansion slot)
- 32 bit paged/interleaved memory controller card
- 8 industry standard expansion slots (two 8 bit, six 16 bit)
- Two serial and one parallel port
- Choice of keyboards (12 function key IBM enhanced compatible or 16 function key Wang/IBM enhanced compatible)
- 229 Watt power supply

Four hard disk drive options

- 42MB 23ms
- 68MB 28ms
- 143MB 23ms ESDI
- 321MB 18ms ESDI

Partial listing of Wang PC options

- Additional 3.5" 1.44MB Diskette Drive.
- Additional 5.25" 360KB or 1.2MB Diskette Drives.
- Intel 80387 math coprocessor (16MHz or 20MHz).
- 100 nanosecond 1MB, or 256KB memory SIMM Modules.
- VGA analog monochrome or color monitor.
- VGA color plus controller.

***ASK ABOUT THE OTHER MODELS AVAILABLE IN OUR COMPLETE FAMILY OF PCs.**

WANG
Microsystems
1-800-962-4727

Circle 244 on Reader Service Card



NOW, who's in charge?

Now, with STAGEHAND you can create Advanced Screens for "C" programming environments without the tedious, time consuming and often expensive development. You are in charge with the ability to make your programs sing with colorful windows that display your data. Whether you are a manager coordinating a large project, a consultant or programmer trying to speed-up development time, STAGEHAND allows you to be in control.

What is a STAGEMANAGER without a STAGEMANAGER?

The STAGEMANAGER library, with its powerful functions, allows you to orchestrate the screens created by STAGEHAND. With the help of the STAGEMANAGER you can manipulate the screens to create Multiple Overlapping Windows, Scrollable Regions, Auto Scrolling Windows, as well as, a symphony of routine support features not found in other screen packages.

ACT NOW and receive PLAYWRITE at No ADDITIONAL CHARGE!

Unlike any other screen package you'll hear about, Datacode Inc. (Creators of STAGEHAND and STAGEMANAGER) will give customers the ability to create full featured demos with PLAYWRITE. For a limited time, we will include with your purchase of STAGEHAND, the PLAYWRITE advantage. With PLAYWRITE you can create a demo without the need to write any program code through the use of a powerful set of easy-to-use commands.

To order, call
1(800)DATACODE

SPECIAL PACKAGE PRICE costs **\$199.00**, which includes FREE Updates, Telephone Support, STAGEMANAGER Source Code and, of course, there are No Royalties or Run-time Fees. Dealer Inquiries Welcomed.

DCI
DATA CODE INCORPORATED

1085 Rt.112, Port Jefferson Sta., N.Y. 11776 (516) 331-7848

deadwood), and make them happy. Turn them loose.

The last three parts of the book are devoted to understanding how to grow teams. First, the authors explore how *not* to do it—ways to avoid "teamicide." Some of the mistakes leading to teamicide are fragmentation of people's time (e.g., one person working on four projects), forced quality reductions, phony deadlines, and defensive management. The authors recommend that managers make a cult of quality and encourage teams with a sense of eliteness and teams that support individuality. The management should provide strategic but not tactical direction.

Peopleware is a sociology book that deserves a place on any technical manager's bookshelf. It's not shelfware, though—take it down and review it before your next team meeting.—Charles Herring

Better Scientific and Technical Writing by Morris I. Bolsky, Prentice Hall, Englewood Cliffs, NJ: 1988, 156 pages, \$14.95. If you write reports, documentation, or even interoffice memos, *Better Scientific and Technical Writing* can help. In a book that practices what it preaches, Morris I. Bolsky (a technical writer for AT&T Bell Laboratories) presents guidelines, tips, and techniques for conveying information in the clearest, most effective manner.

This slim, well-organized volume touches on all aspects of a writing project, from planning to printing. The heart of the book, however, is the chapter entitled "Design—Principles," which offers an excellent set of guidelines for good writing. Explanations and examples support these principles, which stress simplicity and readability in everything from word choice and sentence structure to overall tone and organization. A list on the back cover summarizes this and other material, and it's almost worth the price of the book just to have that

synopsis handy.

Bolsky gives considerable attention to the presentation of information, and he offers tips on such reader aids as footnotes, contents and index, and tables. The chapter on physical design covers the actual printing of a document, from deciding on a typeface to choosing the most readable ink color.

Brief sections on grammar and punctuation provide a quick reference for style questions, and a reasonably comprehensive index makes the book's information easily accessible.

You may not agree with Bolsky on every point—not everyone thinks a table of contents belongs on the cover, and using "they" as a singular pronoun makes a lot of people wince—but Bolsky himself is quick to point out that he offers recommendations, not rules. With that in mind, *Better Scientific and Technical Writing* is a useful handbook for novice writers and a good reference for old hands.

—Margaret A. Richard

C Traps and Pitfalls by Andrew Koenig, Addison-Wesley, Reading, MA: 1989, 147 pages, \$16.25. The product of over 20 years of programming experience, including 10 years using the C language at Bell Labs, *C Traps and Pitfalls* presents the most pervasive of classic goofs and gaffes you're likely to encounter while programming in C.

The book was originally circulated as an internal paper within Bell Labs. Unprecedented enthusiasm there prompted Koenig to turn the paper into a book. All the problems mentioned in the book come from the author's own programming and the experience of other members of Bell Labs' technical staff.

Like any good book dealing with C, it starts with an introduction. Eight more chapters cover lexical, semantic, and syntactic pitfalls, as well as library routines, the preprocessor, portability concerns, and

continued

Leprecard Hard Disk Cards

Leprecards feature components utilizing the latest technology. Low power drives mean less strain on your systems, lower operating temperature, and longer component life. You get a 1 year warranty, unlimited technical support, and our illustrated installation and user's guide. Models available for IBM PC/XT and compatibles, as well as TANDY 1000/A/SX/XT/TL/SL.

FREE SOFTWARE Including TakeTwo, the backup utility PC MAGAZINE named Editors Choice in 1986 & 1987, and PC-KWIK disk caching from Multisoft.

21MB 48ms \$299	32MB 48ms \$339	32MB 40ms \$389	49MB 28ms* \$549	65MB 16ms* \$649
------------------------------	------------------------------	------------------------------	-------------------------------	-------------------------------

* Average access speed per partition

Tandy 1000/A/SX/XT/TL/SL Leprecards add \$20

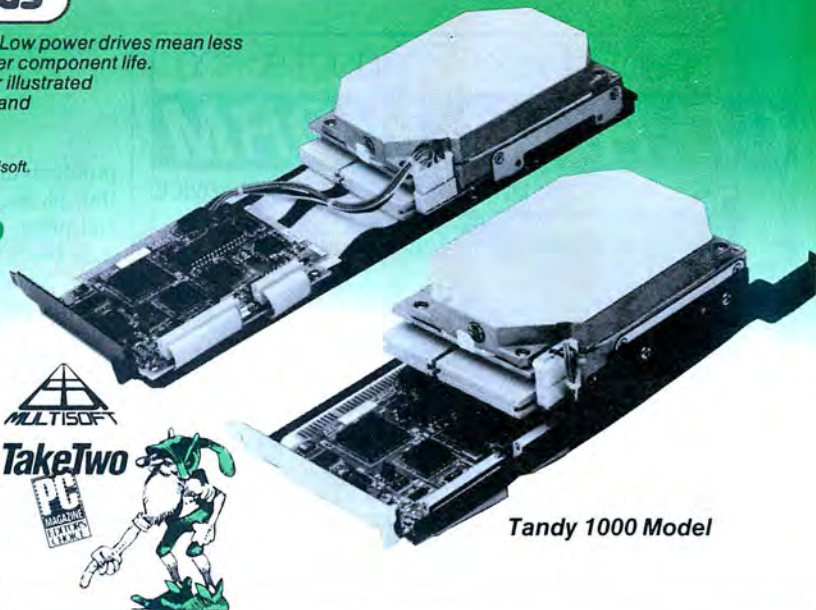

Tandy 1000 Model

3.5" Floppy Kits

Internal kits for PC/XT/AT computers include 5 1/4" mounting brackets, black & gray face plates, and AT rails. 1.44MB for PC/XT includes high speed Western Digital controller.



FREE TAKE TWO floppy backup software.

720 Kit \$109	1.44MB for AT \$139	1.44MB for PC/XT \$199
-------------------------	-------------------------------	----------------------------------



PC/XT Disk Kits

- Pretested & formatted
- Western Digital short slot controller
- 30 page installation guide & reference manual
- Cables, mounting screws, full & half-height face plates
- 1 year Warranty, 30 Day Money Back Guarantee
- Optional: 150 watt, UL/FCC approved power supply for IBM PC's \$69

20MB KIT \$279 • Seagate ST225 - 21.4MB/65ms. Half-Height/14.8 watts	
30MB KIT \$299 • Seagate ST238 - 32.7MB/65ms. Half-Height/14.8 watts	
40MB KIT \$459 • Seagate ST251 42.8MB - Half-Height - 11 watt • pre formatted into a pair of 21MB/28ms partitions.	
65MB KIT \$549 • Seagate ST277R 65.5MB - Half-Height - 11 watts • pre formatted into a pair of 32MB/28ms partitions.	

Tandy 1000 kits add \$20

FREE SOFTWARE Including TakeTwo, the backup utility PC MAGAZINE named Editors Choice in 1986 & 1987, & PC-KWIK disk caching from Multisoft.

Laser Printer

"One of the Laserjet's strongest competitors"
INFOWORLD October 5, 1987

- Serial and Parallel Interfaces
- 120 Day TRW on site maintenance
- 1 Year Warranty
- 100% HP Laserjet II compatible
- 3 Resident fonts in Portrait and Landscape orientation, 23 symbol sets
- Options: All HP style font cartridges



512K **\$1495** 1.5MB **\$1894**

Toner Cartridge \$29

AT Hard Disk Kits

- Includes IBM AT rails, and cables.
- SpeedStor or Ontrack large drive software.
- Formatted, Partitioned & Tested.

SIZE	MODEL	SPEED	CAPACITY	PRICE
HH	Seagate ST251	40ms	42MB	\$359
HH	Seagate ST251-1	30ms	42MB	\$449
HH	Toshiba Drive MK134	25ms	44MB	\$499
FH	Seagate ST4096	28ms	80MB	\$599
FH	Maxtor 1140	27ms	117MB	\$1669
FH	Maxtor 2190	30ms	150MB	\$1999

LepreFAX Boards

- Easy to use POP-up Menus
- Sends ASCII or word processing files
- Internal 4800bps, **\$289** 9600bps **\$559**
- Prints on standard dot-matrix or laser printers
- Sends/Receives from any Group 3 fax machine
- Automated sending during low phone rate periods
- Portable external plugs into PC/XT/AT serial port, **\$359**

External **\$359**

Internal **\$289**



4" Hand Scanner with HALO DPE software **\$269**

2400 Modems

with MNP

External **\$239** Internal **\$229**

Hayes Compatible, 300/1200/2400

MNP Level 4 error correction

FREE MIRROR II Software, a \$69 value

Internal model **\$229**, fits in a short slot

2400 without MNP **\$159** Ext **\$109** Int



- 80286-12Mhz 1 wait state (0 optional) - 8 slot American made motherboard - Room for 1 full and 3 half-height drives - 220 watt power supply, Award BIOS - Serial/Printer ports, Clock/Calendar - Choice of 1.2 or 1.44MB floppy drive - Western Digital 1:1 interleave disk controller - **LepreKeys** Enhanced keyboard with tactile switches & built-in calculator -RAM standard expandable to 1MB, 1 year warranty -30 day money back guarantee.

Complete Systems with:

Monographics Card & Monitor	\$1049
VGA Card & Monochrome Monitor	\$1295
EGA Card & EGA Monitor	\$1469

286¹² Computer



PERFORMANCE COMPARISON

SYSTEM	NORTON SI Ver4.0 MIPS PowerMeter		
	SI	Ver4.0	MIPS PowerMeter
IBM Model 50Z	11.2	1.6	147.2
Compaq 386-16	15.6	2.8	319.9
Shamrock 286-12/0 wait	15.3	2.5	253.3
Shamrock 286-12/1 wait	11.8	1.9	178.9

Orchid VGA Card & Multiscan Monitor	\$1595
Orchid Designer VGA 1024x168 Card & NEC Multisync II Monitor	\$1895



733AA Lakefield Rd., Dept. B, Westlake Village, CA 91361



To order, or get our free catalog call

Toll Free
800 722-AT-XT
California
805-373-7847
FAX
805-379-9345

MMG
MICROCOMPUTER
MARKETING COUNCIL
A Division of Direct Marketing Resources, Inc.

- No extra for Visa/Mastercard (AMEX add 3%)
- Prices include UPS surface shipping
- Federal Express shipping just \$1.50 per pound
- 30 Day Money Back Guarantee
- Corporate & Institutional PO's accepted

Compact Disk Products, Inc. CD-ROM/WORM

ALL PRODUCTS, LOWEST PRICES, EXPERT ADVICE

INTRODUCTORY OFFERS

- Hitachi 1503S or 3500S CD-ROM Drive with your choice of:
 - NEW Programmer's Reference Library (Microsoft) . . . \$995
 - McGraw Hill Science and Technical Reference Set . . . \$920
 - Grolier Electronic Encyclopedia . . . \$995
 - Microsoft Bookshelf or PC65G Library . . . \$895

CD-ROM SOFTWARE

- Oxford English Dictionary . . . **NEW** \$945
- Comstock Stock Photography On CD . . . **NEW** \$445
- Educorp Public Domain/Shareware for the Mac . . . **NEW** \$179
- The New Grolier Electronic Encyclopedia . . . \$359
- McGraw Hill or Bookshelf or PC65G (Add \$25 for McGraw) . . . \$259
- The Bible Library . . . \$495
- Kirk-Othmer Encyclopedia of Chemical Technology . . . \$645
- Registry of Mass Spectral Data . . . \$2655
- Geovision U.S. Atlas and Mapmaker . . . \$795

TOLL FREE ORDER LINE • 800-MEGABYTE (634-2298)

CD-ROM and WORM DRIVES

- Hitachi 1503S External CD-ROM Drive with Audio . . . \$729
- 1503S with Digital Audio Output and CD-Capture . . . \$1229
- Hitachi 3500S Internal 1/2 Height CD-ROM Drive w/Audio . . . \$719
- NEC Intersect CD-ROM Drives for the Apple/Mac . . . CALL
- Maxtor 800 MB WORM Drive . . . \$3999
- Portable 286 with CD-ROM Drive and Hard Disk . . . CALL

- CD-Play (\$99) Pop-up utility that permits user to play all audio CDs on Hitachi and compatible drives. Output to headphones or amplifier.
- CD-Play Sampler (\$149) Same features as CD-Play plus the ability to name two points on an audio CD and loop between them.
- CD-AudioFile (\$149) Automatically creates database records of all your audio CDs. Allows you to store a preferred play sequence for each disk. Automatic recognition of CDs. Creates DBase compatible records.

Compact Disk Products
223 E. 85th St.
New York, NY 10029
Tel. 212-737-8400
Fax 212-439-9109
CompuServe 75530214

INTERNATIONAL ORDERS A SPECIALTY

- | | | |
|---------------------------|-------------------|---------------------|
| International Agents: | Australia | Australia |
| United Kingdom | Kewtel | Light Years Ahead |
| CORDM - New Manor Farm | 145 Cotham Road | PO Box 561 |
| Winterslow Near Salisbury | New Victoria 3101 | Wahroonga, NSW 2078 |
| WILTS SP5 1SE | Tel. 03-917-9533 | Tel. 02-47-8886 |
| Tel. 0880-892890 | | |

PRICE SLASHED!

FREE Software!



SONY Quality

THE 3.5" CONNECTION!

The perfect solution for upgrading your existing PC/XT/AT to "State Of The Art" 3.5" floppy disk technology! The Model 853W (720K) and Model 873W (1.44MB/720K) 3.5" drives are "drop-in" replacements for 5.25" drives! Disk format is fully compatible with popular Laptops (IBM, Toshiba, Zenith, etc.) and the new IBM PS/2 models. Both units come completely assembled and contain everything that you need, including Premium SONY drive, interface adapters, software device drivers and complete documentation. These drives utilize your existing controller so no additional slots are required (1.44MB requires AT class controller or special PC/XT High-Density Controller available from Tigertronics). Available with gray or black bezel (specify).

Model 853W
(720K)
~~\$159.95~~
\$129.95



Model 873W
(1.44MB)
~~\$229.95~~
\$159.95

400 Daily Lane • P.O. Box 5210
Grants Pass, Oregon 97527



IMMEDIATE DELIVERY!
Call 503 474-6700 or 503 474-6701
FAX 503 474-6703



problems that occur during the link phase. The style is lean and pithy, with section headings like "Memory location zero" and "= is not ==." Pitfalls are amply illustrated with C code fragments. The examples also examine the anomalous program behavior caused by a given programming error. Where appropriate, the book lists differences that might occur while using proposed ANSI C versus one of the older commercial versions of C. Each chapter concludes with a few useful exercises, the answers to which are at the end of the book. An appendix gives the most complete discussion of the printf command that I've ever seen.

For the novice C programmer, this book will provide a relief from an almost certain future of chaos. The professional programmer will chuckle upon encountering certain familiar pitfalls but will also gain a better insight into these. The book is easy to read, yet it contains a lasting store of information for any C programmer.—Jason Levitt

What Do You Care What Other People Think? by Richard Feynman, W. W. Norton and Co., New York: 1988, 255 pages, \$17.95. If there is one scientist who deserves to have his adventures cataloged in a hagiography, it is Richard Feynman: winner of the Nobel prize in physics, a distinguished member of the National Academy of Sciences, onetime actor, artist, and sometime drummer in a Brazilian samba band.

This book is a continuation of tales from Feynman's life, following the best-selling success of *Surely You Must Be Joking, Mr. Feynman*. The first section of the book is filled with personal stories and memories told in a grandfatherly style. The second section focuses on the space shuttle program and on the investigation of the Challenger explosion. It is a treat for those who love Feynman's chutzpah and a lesson for anyone involved in a large engineering project. Feynman turned out to be the only member of the President's investigative committee not working for the Air Force or NASA. He realized this gave him the freedom to ask difficult questions, and he took advantage of that opportunity.

At the time, Feynman found that a bit of bureaucratic hardening of the arteries had set in at NASA. The different engineering problems were gradually coated over with sugar as each manager briefed his boss. As a result, upper management steadfastly adhered to a failure probability estimate of 1 in 100,000 launches, while the working engineers said it was 1 in 100.

Computer scientists will find particular interest in the chapters on the software that runs the space shuttle. That side of the NASA effort uses very rigorous standards that require adversarial teams to try and find problems in each other's code. Feynman died last February, and this will likely be the last published collection of his anecdotes. The book makes excellent reading both for its entertaining style and for Feynman's keen insights.

—Peter Wayner ■

CONTRIBUTORS

David A. Mindell is a technical consultant who lives in Aspen, Colorado. **G. Michael Vose** is coeditor of *OS Report: News and Views on OS/2*. He lives in Peterborough, New Hampshire. **Charles Her-ring** is a computer scientist at the U.S. Army Construction Engineering Research Laboratory in Champaign, Illinois. **Margaret A. Richard** has a Certificate in Technical Communications from the University of Lowell. She is a copy editor for *BYTE*. **Jason Levitt** is a Unix aficionado and freelance writer based in Austin, Texas. **Peter Wayner** is a doctoral student in computer science at Cornell University.

Six ~~Five~~ easy ways to boost your BASIC

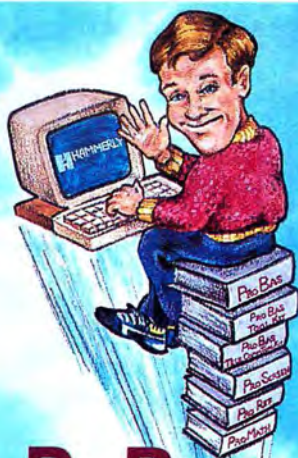

PROBAS™ ^{updated} Professional Basic Programming Library

Announcing PROBAS Version 3.0, now with over 335 assembly routines to really kick QuickBASIC and BASCOM into high gear. BYTE magazine calls PROBAS a "Super-charger for QuickBASIC". Thousands of programmers rely on PROBAS to make their life easier and to enhance their programs with features like:

- An 800-page 3-part manual
- Full-featured windowing
- Screen snapshots (Text & Graphics)
- String, array, and pointer sorts
- Lightning-fast file I/O
- Full mouse support

Create dazzling screens in text mode, CGA, EGA, VGA or Hercules graphic modes. Save and restore screen snapshots to arrays, EMS memory or files. Full featured windowing to meet the most demanding jobs. The PROBAS system of virtual screens allows you to draw full or partial screens to memory, and then snap them on in an eyeblink. You can even create virtual screens far larger than the display screen.

Sick of running out of string space? Store hundreds of K in numeric arrays or megabytes in extended or expanded memory. Tired of using a kludgy SHELL to DIR to read a directory or archive files? Scan sub-directories or .ARC files using wild-cards and store thousands of file names, dates, and times. Wish you could drag a window containing text or a menu around the screen with a mouse? It's easy!

PROBAS gives you a complete set of blazingly-fast file routines. Read or write huge chunks of data at a clip, with file locking and error handling so that you can even use them in subprograms. You'll never want to use BASIC's file I/O again! Sort data with lightning fast array and pointer sorts. Search files or arrays at assembly speeds. PROBAS also has over 200 other essential services including handy string, date, time, directory and array manipulation, string, screen and data compression, full mouse support, valuable equipment and input routines and faster replacements for most BASIC commands.

Whether you are a professional or a novice, PROBAS will boost your BASIC in ways you never dreamt possible. PROBAS allows professionals to save time and work and lets novices write professional-quality programs quickly and easily. After all, how much is a few hundred hours of your time really worth?

For all versions of QuickBASIC and BASCOM including BASCOM 6.0 for OS/2. **Just \$135.00!**

PROREF™ On-Line Help For PROBAS

PROREF provides pop-up help for the routines in PROBAS and is an extension of the QuickBASIC programming environment. Find help on any routine with a few key-strokes or mouse clicks. Pop-up an ASCII chart, calculator, scan code module, box diagram, your own help information or almost any DOS program via a hot-key. **Just \$50.00!**

PROSCREEN™ Professional Screen Management System

PROSCREEN is a full-featured screen generator/editor that will save you more design and coding time than you ever thought possible. PROSCREEN treats screens like a word processor treats text to provide complete control over characters, colors, and placement. Design input screens with up to 130 fields and 19 pre-defined and 2 user-defined masks. Use PROBAS or the included BASIC/Assembler subroutines to access the screens. No kludgy code generators here! Comes with subroutine source, extensive on-line help, and a 285 page manual. **Just \$99.00!**

PROMATH™ ^{new!}

PROMATH is a collection of over 150 high-level routines that provide mathematical functions and operations for programmers who often work in mathematics, science, or engineering. Complex variables, real and complex matrices, real and complex trigonometric and hyperbolic functions and their inverses, solution of linear equations, integration, differential equations, Fast Fourier transforms and many other useful routines are provided.

For years Fortran has been the language of choice for scientific and engineering applications, but it lacks many of the useful features of QuickBASIC. PROMATH contains most of the Fortran mathematical and numeric functions and allows you to easily translate Fortran code to BASIC or write new programs in BASIC while retaining Fortran's numerical prowess.

The PROMATH manual is over 200 pages and provides a complete description of each routine, including any algorithm and the mathematical formula the routine uses, shown in standard notation. For QuickBASIC 4 and BASCOM 6 only. **Just \$99.00!**

PROBAS™ TOOLKIT

The TOOLKIT is a collection of assembly and BASIC modules that use the PROBAS library to save you even more hours of grunt work. Why spend hundreds of hours re-inventing the wheel when you can just plug in TOOLKIT modules like:

- Menu Generators
- Fast B-tree indexing
- Mini-editor with word-wrap
- Patch .EXE files
- Protected storage areas
- Julian date routines

The TOOLKIT also includes clock, calendar, windowing, BCD math routines and much more, complete with BASIC source code and a comprehensive manual. The PROBAS TOOLKIT adds capabilities and helps conserve your most valuable asset of all—time! Requires PROBAS. **Just \$99.00!**

PROBAS™ TELECOMM TOOLKIT

The PROBAS TELECOMM TOOLKIT is a collection of high-level communications modules that you plug into your code to provide popular file transfer protocols, terminal emulations, login scripts and baud rates up to 115,200 baud. You get:

- Xmodem/Modem7/Xmodem-1k
- Ymodem (single and batch)
- CRC-16 and Checksum
- VT52, VT100, ANSI BBS etc.
- Auto Dialer & data base
- Documented BASIC source

Why use clumsy SHELLS to complex terminal programs when you can plug just the communications routines you need into your code? Implement just the features and commands you want. Requires PROBAS. **Just \$75.00!**

Our thirty day, money-back guarantee assures you the highest quality and our technical support staff is always ready to help. Try our BBS at (301) 953-7738 or give us a call at:

HAMMERLY
COMPUTER SERVICES, INC.

8008 SANDY SPRING ROAD • LAUREL, MD 20707
INTERNATIONAL CALLS: (301) 953-2191

(800) 343-7484

FAX # 301-725-8147

Add \$5.00 per item (\$8.00 Canada) for shipping per order. Europe: \$39.00 for 1st item plus \$5.00 for each additional item. Visa, M/C, C.O.D. (US Only) checks and approved POs accepted. Trademarks PROBAS, PROREF, PROSCREEN, PROMATH: Hammerly Computer Services, Inc. QuickBASIC, BASCOM: Microsoft Corp.

Programmer's Paradise Stocks *over*



WE'LL MATCH NATIONALLY ADVERTISED PRICES.

ASSEMBLY LANGUAGE

	LIST OURS	OURS
Advantage Disassembler	295	279
MS Macro Assembler	150	99
OPTASM	125	105
SOURCER	100	89
w/ BIOS SOURCE	140	125
Turbo Assembler/Debugger	150	105
Visible Computer: 80286	100	89

BASIC

	LIST OURS	OURS
db/LIB	139	121
GraphPak Professional	149	127
Facelt	99	90
MS BASIC/6.0	295	199
MS QuickBASIC 4.5	99	69
QuickPak Professional	149	129
QuickWindows	79	70
w/Source	99	90
QuickWindows Advanced	139	125
Quick-Tools	130	111
True BASIC	100	80
Turbo Basic	100	69
SoftCode	79	69

C LANGUAGE

	LIST OURS	OURS
C-terp	298	232
Lattice C	450	289
Microsoft C	450	299
QuickC	99	69
w/ serial mouse	249	149
RUN/C Professional	250	159
Turbo C v. 2.0	150	105
Turbo C v. 2.0 Professional	250	175
Watcom C	295	269
Zortech C++	100	90
w/ source	150	135

C LIBRARIES/UTILITIES

	LIST OURS	OURS
C ASYNCH MANAGER	175	129
C TOOLS PLUS/5.0	129	95
C Utility Library	199	139
DESQview API C Library	200	165
Essential Communications	185	125
Greenleaf Comm Library	229	169
Greenleaf Functions	209	155
Greenleaf SuperFunctions	265	189
Greenleaf TurboFunctions	109	79
PC-lint	139	101
PCYACC	395	359
TimeSlicer	295	279
w/ source	1000	899
Turbo C TOOLS	129	95
vLIB	99	89
w/ source	149	129

C GRAPHICS

	LIST OURS	OURS
Essential Graphics	299	229
w/ source	595	509
Graphic	395	322
GSS Graphic Dev. Toolkit	595	489
HALO '88	325	229
HALO '88 for MS Devel.	595	399
MetaWINDOW	195	162
MetaWINDOW/PLUS	275	232
TurboHALO	100	80

C SCREENS/WINDOWS

	LIST OURS	OURS
Curses (Aspen)	119	105
w/ source	289	249
C-Scape	299	282
C Windows Toolkit	100	90
Greenleaf DataWindows	295	209
Greenleaf Makeform	125	90
HI-SCREEN XL	149	129
JAM	750	684
JYACC FORMAKER	495	453
PANEL Plus	495	395
PANEL/QC or /TC	129	99
Vitamin C	225	162
VCScreen	149	109
Windows for Data	295	259
w/ Source Code	590	479

COBOL LANGUAGE

	LIST OURS	OURS
Micro Focus COBOL/2	900	733
Micro Focus COBOL/2 Toolset	900	733
PC-CICS	1495	CALL
Personal COBOL	149	121
Microsoft COBOL 3.0	900	599
Realia COBOL	995	799
w/ RealMENU	1145	929
RM/COBOL	950	763

COMMUNICATIONS

	LIST OURS	OURS
Carbon Copy Plus	195	135
Close-Up (Support)	245	222
Close-Up (Customer)	195	116
Co/Session (2 user license)	249	227
Support Application	175	157
RELAY Gold	125	116
RELAY Silver	250	229
SideTalk	150	139
	120	90

dBASE LANGUAGE

	LIST OURS	OURS
CLARION	695	599
Clear +	200	165
Clipper	695	439
dBASE III Plus	695	399
dBASE IV	795	485
dBASE Graphics for C	90	69
dBASE ON LINE	69	60
dBASE Programmers Utilities	90	79
dBASE Tools for C	90	69
dBASE Tools for Pascal	90	69
dBFast	100	75
DEBUG	195	179
dQUERY	150	129
FoxBASE+	395	249
Flipper	195	182
Genifer	395	259
Integrated Dev. Library	149	135
QuickSilver	599	369
R:Base for DOS	725	529
R & R	150	129
w/ Clipper/FoxBASE module	199	179
Say What!	50	45
Scrimage	CALL	CALL
SilverComm Library	150	139
The Documentor	295	229
Tom Rettig's HELP	120	CALL

Tom Rettig's Library
 UI Programmer
 XDB-SQL

DEBUGGERS

	LIST OURS	OURS
386 DEBUG	195	145
Advanced Trace 86	175	121
Periscope I/512 K	795	636
Periscope II	175	141
Periscope IIx	145	106
Periscope III 10 MHz	1395	1195
Sherlock	195	179
Trapper	150	CALL

DESKTOP PUBLISHING

	LIST OURS	OURS
HALO DPE	195	162
MKS SQPS	495	420
Pagemaker	695	532
Ventura Publisher	895	554

DISK/DOS UTILITIES

	LIST OURS	OURS
Command Plus	90	70
Command Tips	90	80
Disk Optimizer	60	55
FANSI CONSOLE	75	66
FASTBACK Plus	189	142
hTest hFormat	90	80
MACE Utilities	99	90
MKS Toolkit	199	169
Norton Commander	89	56
Norton Guides	100	75
Norton Utilities	100	61
Norton Utilities, Adv. Ver.	150	101
Pathfinder	70	65
PC/Tools Deluxe	80	70
Vcache	50	47
Vfeature	80	75
Vfeature Deluxe	120	111
Vopt	50	47
Xtree	70	60
Xtree Pro	129	111

EDITORS

	LIST OURS	OURS
BRIEF	195	CALL
Epsilon	195	151
KEDIT	150	120
ME	89	79
w/ source	189	169
MKS VI	149	127
Multi-Edit	99	90
Norton Editor	75	70
PC/EDIT+	295	269
Pi Editor	195	155
Slick Editor	195	155
SPF/PC	245	185
VEDIT PLUS	185	115
Vq	270	CALL

FILE MANAGEMENT

	LIST OURS	OURS
Btrieve	245	185
Xtrieve	245	189
Report Option	145	109
Btrieve/N	595	455
Xtrieve/N	595	459
Report Option/N	345	279
CBTREE	159	141
c-tree	395	318
d-tree	495	395
r-tree	295	241
c-tree/r-tree bundle	650	523
CQL Query System	395	332
DBC III	250	CALL
DBC III PLUS	750	CALL
db-RETRIEVE	395	322
db-FILE	395	322
Essential B-Tree	99	89
w/ source	198	179
Informix ESQ/C	595	535
Informix 4GL	995	895
Informix SQL	795	715
XQL	795	599

FORTRAN COMPILERS

	LIST OURS	OURS
F77L	477	429
Laney Personal FORTRAN 77	95	89
MS FORTRAN	450	299
RM/FORTRAN	595	479

FORTRAN LIBRARIES/UTILITIES

	LIST OURS	OURS
Gramatic	135	119
Plotmatic	135	119
Spindrift Library	149	135
Tekmar Graphics Library	195	169

LINKERS/LIBRARIANS

	LIST OURS	OURS
OPTLIB	49	45
OPTLNK	125	109
Plink86plus	495	279
Plib	195	149
PolyLibrarian I	99	90
PolyLibrarian II	149	131

MODULA-2

	LIST OURS	OURS
JPI Top Speed Modula-2	100	90
LOGITECH Modula-2		
Development System	249	199
Solid B + Toolbox	100	90
Stony Brook Modula-2		
Development Package	345	309

OBJECT-ORIENTED PROGRAMMING

	LIST OURS	OURS
ACTOR	495	423
C-talk	150	129
Smalltalk/V	100	85
Communications	50	45
EGA/VGA Color Ext.	50	45
Goodies #1, #2 or #3	50	45
Smalltalk/V 286	200	169

OPERATING SYSTEMS

	LIST OURS	OURS
Concurrent DOS 386	395	349
Microport:		
System V/AT (complete)	649	549
AT Runtime System	249	209
286 DOS Merge	249	209
SCO:		
XENIX Sys V (comp.)	1295	999
Operating System	595	479

WENDIN:

	LIST OURS	OURS
Operating System Toolbox	99	80
PCNX	99	80
PCVMS	99	80
Wendin-DOS	139	109

OS/2 DEVELOPMENT TOOLS

	LIST OURS	OURS
Btrieve for OS/2	595	455
Epsilon for OS/2	195	151
Greenleaf DataWindows	395	CALL
GSS Dev. Toolkit for OS/2	CALL	CALL
LOGITECH Modula-2	349	279
MS Languages	CALL	CALL
NeWS/2	495	CALL
PolyAWK for OS/2	199	179
Panel Plus for OS/2	495	395
Rbase for OS/2	895	CALL
Vitamin C (OS/2)	345	279
Windows for Data (OS/2)	395	349

PROTOTYPING

	LIST OURS	OURS
C-Scape	299	282
Dan Bricklin's Demo Program	75	60
Dan Bricklin's Demo Program II	195	179
Dan Bricklin's Demo Tutorial	50	45
Instant Replay	150	131
Proteus	149	129
Screen Machine	79	60
Screen Star	99	85
w/ source code	198	169

REFERENCE GUIDES

	LIST OURS	OURS
Command Tips	90	80
Norton On-Line Prog. Guide	100	75
Tom Rettig's HELP	120	105

PASCAL COMPILERS

	LIST OURS	OURS
Microsoft Pascal	300	189
Turbo Pascal	150	105
Turbo Pascal 5.0 Professional	250	175

TURBO PASCAL LIBRARIES/UTILITIES

	LIST OURS	OURS
DATABOSS	399	359
DATABOSS TOOLS	99	89
Overlay Manager	45	39
PCX Toolkit	90	80
Pascal ASYNCH MANAGER	175	129
POWER SCREEN	129	95
Turbo Analyst	99	79
Turbo ASYNCH PLUS	129	95
Turbo Geometry Library	150	135

NEW RELEASES

NeWS/2
 New for OS

1,000 Brand Names 1-800-445-7899

This Month's Specials from Blaise Computing

	LIST	OURS
ASYNCH MANAGER	175	129
C TOOLS PLUS/5.0	129	95
EXEC	95	75
Key Pilot	50	45
PASCAL TOOLS / TOOLS 2	175	137
POWER SCREEN	129	95
RUNOFF	50	45
Turbo ASYNCH PLUS	129	95
Turbo C TOOLS	129	95
Turbo POWER TOOLS PLUS	129	95

LIST OURS

Turbo MAGIC	199	179
Turbo Plus v. 5.0	100	80
Turbo POWER TOOLS PLUS	129	95
Turbo Professional 5.0	125	99
Universal Graphics Library	150	121

SCIENCE/ENGINEERING SOFTWARE

CSS	495	459
DesignCAD 3-D	299	219
EXP	150	129
HiWIRE-Plus	895	805
MathCAD	349	279
MICRO-CAP III	895	759
Microstat-II	395	349
MuMATH	295	199
Systat	595	549
Tango PCB	495	469
TECH*GRAPH*PAD	395	359

TRANSLATORS

Bas.C (Economy)	199	179
Bas.C (Commercial)	375	323
Bas.Pas (Economy)	149	129
Bas.Pas (Commercial)	280	242
BASTOC	495	399
Brooklyn Bridge	130	109
dB2C	299	272
dBx TRANSLATOR	550	469

386 SOFTWARE

386 ASM/LINK	495	389
386MAX	75	66
386MAX PROFESSIONAL	129	115
Concurrent DOS 386	395	349
DESQview/386	190	165
F77L-EM/32	895	805
High C 386	895	799
Microport		
System V/386 (complete)	899	799
Runtime System	299	269
MS Windows/386	195	130
NDP C 386	595	529
NDP FORTRAN-386	595	529
SCO XENIX		
Operating System	695	589
Sys. V 386 (complete)	1495	1195
VP/IX (2-USERS)	495	399
VP/IX (unlimited users)	995	799
VM/386	245	199
VM/386 Multiuser (unlim.)	895	CALL

OTHER PRODUCTS

FLOW CHARTING II	229	207
MuLisp-87	300	219
MuLisp-87 Interp/Compiler	400	299
PC Scheme	95	79
Pfinish	395	215
PolyDoc	199	179
Source Print	97	80
Tree Diagrammer	77	70

BORLAND

Eureka: The Solver	167	119
Paradox 2.0	725	529
Paradox Network Pack	995	729
Paradox 386	895	625
SideKick	85	59
SideKick Plus	200	139
Turbo Basic	100	69
Database Toolbox	100	69
Editor Toolbox	100	69
Turbo Assembler/Debugger	150	105
Turbo C 2.0	150	105
Turbo C 2.0 Professional	250	175
Turbo Pascal 5.0	150	105
Turbo Pascal 5.0 Professional	250	175
Database Toolbox	100	69
Editor Toolbox	100	69
Gameworks Toolbox	100	69
Graphix Toolbox	100	69
Numerical Methods Toolbox	100	69
Tutor	70	45
Turbo Prolog	150	105

GREENLEAF SOFTWARE INC.

Greenleaf Functions	209	149
Greenleaf Comm Library	229	169
Greenleaf TurboFunctions	109	79
Greenleaf DataWindows, DOS	295	209
OS/2 Version	395	299

LIST OURS

Greenleaf Bus. MathLib	325	229
Greenleaf SuperFunctions	265	189
Greenleaf MakeForm	125	99
OS/2 Version	170	135
Greenleaf DataMath Interface	75	69

LAHEY

F77L	477	429
F77L-EM/16	695	639
F77L-EM/32	895	805
A.I. DEVELOPER'S KIT		
OPERATING SYSTEM	495	459
PERSONAL FORTRAN 77	95	89

MEDIA CYBERNETICS

Dr. HALO III	140	101
HALO DPE	195	162
HALO '88	325	229
HALO '88 - MS Developers	595	399
TurboHALO for C	100	80

MICROSOFT

MS BASIC/6.0	295	199
MS C	450	299
MS COBOL V. 3.0	900	599
MS Excel	495	329
MS FORTRAN	450	299
MS Learning DOS	50	40
MS Mach 20	495	329
MS Macro Assembler	150	99
MS Mouse Serial or Bus		
w/Paintbrush	150	99
& Mouse Menus	175	119
w/EasyCAD	200	139
w/Paintbrush & Windows	350	229
MS OS/2 Prog. Toolkit	300	199
MS Pascal	99	69
MS QuickBASIC	99	69
MS QuickC	195	130
MS Sort	99	69
MS Windows/286	195	130
MS Windows/386	500	319
MS Windows Dev. Kit	450	285
MS Word	149	99
MS Works		

MORTICE KERN SYSTEMS

MKS Awk	99	85
MKS Lex: Yacc	249	212
MKS Make	149	127
MKS RCS	189	161
MKS SQPS	495	420
MKS Toolkit	199	169
MKS Trilogy	119	101
MKS Vi	149	129

NOVELL

Btrieve	245	185
Xtrieve	245	189
Report Option	145	109
Btrieve/N	595	455
Xtrieve/N	595	459
Report Option/N	345	279
XQL	795	599

RAIMA

db-RETRIEVE	395	322
Single user w/source code	890	725
Multi-user	595	485
Multi-user w/source code	1390	1133
db-FILE	395	322
Single user w/source code	890	725
Multi-user	595	485
Multi-user w/source code	1390	1133
WKS LIBRARY	195	179

Phone Orders

Hours 9 AM - 7 PM EST. We accept MasterCard, Visa, American Express. Include \$3.95 per item for shipping and handling. All shipments by UPS ground. Rush service available.

Mail Orders

POs by mail or fax are welcome. Please include phone number.

International Service

Call or fax for information.

Dealers and Corporate Accounts

Call for information.

Unbeatable Prices

We'll match nationally advertised prices.

Return Policy

30-day no-hassle return policy. Some manufacturer's products cannot be returned once disk seals are broken.

turboMAGIC 2.0

Widely acclaimed code generator for Turbo Pascal with the powerful form painter and interactive menu editor, you can create a state-of-the-art user interface in minutes. Fast pop-up windows with scrolling, bullet-proof input, context-sensitive and indexed help windows, 26 modifiable field types, mouse interface, directory search windows, end-user color installation, and much more.

**sophisticated
software**

List: \$199
Ours: \$179



db-FILE 2.22 and db-RETRIEVE



db-FILE is the only file manager you'll ever need. Other file managers deliver B-tree/ISAM capabilities, but they slow down as the application increases in size or complexity. Only db-FILE combines B-tree/ISAM capabilities with full network model database capabilities. You can add even more performance with db-RETRIEVE. It provides the familiar relational view, through SQL, of a db-FILE network model database... without sacrificing the performance!

RAIMA
CORPORATION

CALL FOR PRICES!

TimeSlicer

TimeSlicer is the most popular linkable library of C functions for creating multitasking and real-time programs at the application level rather than interfacing with the operating system.

TimeSlicer will allow an unlimited number of tasks to be running concurrently. You can create, suspend or terminate tasks at run-time. Preemptive and non-preemptive modes are supported, as well as waking-up of tasks to optimize special event processing. TimeSlicer C functions can be installed to replace or complement any interrupt service routine.

TimeSlicer is the better choice for creating multitasking programs, giving you greater control and more efficient implementation of your multitasking application than its operating system counterparts.

List: \$295 Ours: \$279

LIFEBOAT[®]

NeWS/2

NeWS/2 is the new PostScript based, network/extensible window system for OS/2. As the foundation for OPEN LOOK, NeWS/2 is based on the client-window server model, and is accessible thru named pipes from any

NeWS/2

machine on a OS/2 LAN-Manager network. NeWS/2 utilizes the powerful PostScript programming language on the screen to provide unprecedented WYSIWYG as well as run-time extensibility of the window server.

NeWS/2 is fully compatible with Sun Microsystems' NeWS version 1.1, making NeWS the only graphics window technology available on Unix workstations, OS/2 and the Macintosh.

List: \$495 Ours: CALL



In NY: 914-322-4548

Customer Service: 914-332-0869

International Orders: 914-332-4548

Telex: 510-601-7602

Fax: 914-332-4021

Call or Write for
Latest Free Catalog!

1-800-445-7899

Programmer's
Paradise



A Division of Magellan Software Corp
55 South Broadway, Tarrytown, NY 10591

Circle 182 on Reader Service Card

IT'S TIME TO DO SOME SERIOUS 386 BUGBUSTING!

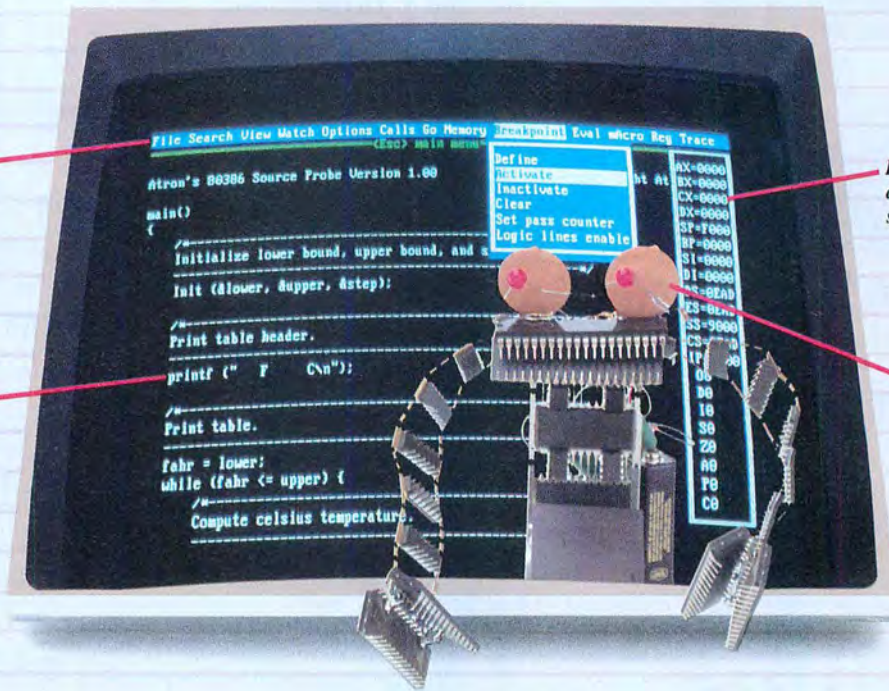

PROBE's menu bar and pull-down menus set a new standard for debugger interfaces.

POP registers up and down with a single key.

PROBE has source-level debugging to let you "C" your program.

This is an out-of-range memory-overwrite bug. Since it is interrupt related, it only appears in real time.

Welcome to your nightmare. Your company has bet the farm on your product. Your demonstration wowed the operating committee, and beta shipments were out on time. Then wham!

All your beta customers seemed to call on the same day. "Your software is doing some really bizarre things," they say. Your credibility is at stake. Your profits are at stake. Your sanity is at stake.

THIS BUG'S FOR YOU

You rack your brain, trying to figure something out. Is it a random memory overwrite? Or worse, an overwrite to a stack-based local variable? Is it sequence dependent? Or worse, randomly caused by interrupts? Overwritten code? Undocumented "features" in the software you're linking to? And to top it off, your program is too big. The software debugger, your program and its symbol table can't fit into memory at the same time. Opening a bicycle shop suddenly isn't such a bad idea.

THIS DEBUGGER'S FOR YOU

Announcing the 386 PROBE™ Bugbuster,* from Atron. Nine of the top-ten software developers sleep better at night because of Atron hardware-assisted debuggers. Because they can set real-time breakpoints which instantly detect memory reads and writes.

Now, with the 386 PROBE, you have the capability to set a *qualified breakpoint*, so the breakpoint triggers only if the events are coming from the wrong procedures. So you don't have to be halted by breakpoints from legitimate areas. You can even detect obscure, sequence-dependent problems by stopping a breakpoint only after a specific chain of events has occurred in a specific order.

Then, so you can look at the cause of the problem, the 386 PROBE automatically stores the last 2K cycles of program execution. Although other debuggers may try to do the same thing, Atron is the only company in the world to dequeue the pipelined trace data so you can easily understand it.

Finally, 386 PROBE's megabyte of hidden, write-protected memory stores your symbol table and debugger. So your bug can't roach the debugger. And so you have room enough to debug a really big program.

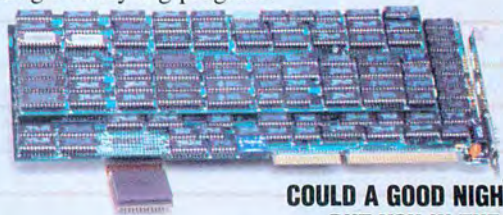

COULD A GOOD NIGHT'S SLEEP PUT YOU IN THE TOP TEN?

Look at it this way. Nine of the top-ten software products in any given category were created by Atron customers. Maybe their *edge* is — a good night's sleep.

Call and get your free, 56-page bugbusting bible today. And if you're in the middle of a nightmare right now, give us a purchase order number. We'll FEDEX you a sweet dream.



Atron
BUGBUSTERS

A division of Northwest Instrument Systems, Inc.
Saratoga Office Center • 12950 Saratoga Avenue
Saratoga, CA 95070 • Call 408/253-5933 today.

*Versions for COMPAQ, PS/2-80s and compatibles. Copyright © 1987 by Atron. 386 PROBE is a trademark of Atron. Call 44-2-855-888 in the UK and 49-8-985-8020 in West Germany.

TRBA

WHAT'S NEW

SYSTEMS

Where Other Computers Would Just Slide Off

The Crayon 386 20/20 SP is a full-featured computer for the rugged industrial environment where only rack-mounted machines survive. Yet it's portable enough—17 by 20 by 8 inches and 32 pounds—to get you between jobs.

The zero-wait-state microprocessor and Award BIOS get you started with a megabyte of system RAM that's expandable to 16 megabytes (all of which is addressable through the 32-bit data path). Your graphics applications can be stored on 5¼- and 3½-inch disks, and there's a SCSI adapter for up to seven peripherals. You can add up to six half-height drives for additional storage capacity.

Two temperature-controlled fans are mounted on the back panel. There are also eight full-length expansion slots. MS-DOS 4.0 is included, as is a Honeywell 100-key keyboard.

Price: \$7495.

Contact: Video Graphic Systems, 4163 St. Clair Ave., Studio City, CA 91604, (818) 509-5738.

Inquiry 1142.

Transputer Box for AppleTalk Networks

Supercomputer performance on a Macintosh network? That's what a small New York company claims with its parallel-processing box called Chorus.

The box is a tower-size system that can hold 4 to 16 parallel processors with 1 megabyte of memory for each



The Crayon 386 20/20 SP is rack-mounted for rugged conditions.

processor. In addition, Chorus has provisions for network connectors that allow it to be accessed by a number of Macintoshes.

In the present configuration, Chorus uses four T-800 transputers. The number of processors can be expanded to 16, 4 at a time. Its manufacturer, Human Devices, claims that each transputer is about five times as powerful as a 68020/68881 processor combination. Future versions may use other processors.

Several Macs can share Chorus as a computational server. Programmers can access the processors by using a parallel-processing operating system from Yale University called Linda (see the article "Getting the Job Done" by David Gelernter in the November 1988 BYTE). Linda statements can intermix with C

code in the Mac's MPW environment.

Human Devices claims programmers will be able to have Mac applications farm out computationally intensive tasks to Chorus. The company will also provide a Chorus-emulator software package that will allow programmers to write and test Chorus applications without actually having one on a network.

Chorus includes an AppleTalk connector for connection to a Mac network and has provisions for Ethernet. The company says that in the future it may have a version of Chorus for the IBM PC. **Price:** \$25,000.

Contact: Human Devices, Inc., 322 West 71st St., New York, NY 10023, (212) 580-0257.

Inquiry 1140.

SEND US YOUR NEW PRODUCT RELEASE

We'd like to consider your product for publication. Send us full information, including its price, ship date, and an address and telephone number where readers can get further information. Send to New Products Editor, BYTE, One Phoenix Mill Lane, Peterborough, NH 03458. Information contained in these items is based on manufacturers' written statements and/or telephone interviews with BYTE reporters. BYTE has not formally reviewed each product mentioned. These items, along with additional new product announcements, are posted regularly on BIX in the *microbytes.sw* and *microbytes.hw* conferences.

Modular CPU Machine in Small Tower

The VIP SX386 from Advanced Logic Research (ALR) is a small-footprint 16-MHz desktop computer with a "modular" plug-in CPU for later upgrade to a 20-MHz Intel 80386.

It's also packaged in a short-tower configuration, measuring 7 inches high, 4½ inches wide, and 15 inches deep and weighing only 17 pounds. But that miniature size doesn't stop it from packing in lots of features: one 8-bit and four 16-bit slots, a 40-megabyte hard disk drive, and a 1.44-megabyte 3½-inch floppy disk drive that's PS/2-compatible.

As with most other ALR machines, the company claims faster computing power than similarly configured Compaq computers. With a proprietary FlexCache architecture as a "cache management scheme," ALR claims 30 percent better performance over Compaq's 80386SX machines. Hardware on the VIP SX386 includes an 82385 cache controller and 512K bytes of RAM (expandable to 8 megabytes).

A 40-megabyte internal hard disk drive in a 3½-inch form factor is optional. **Price:** \$2395; with 40-megabyte internal hard disk drive, \$3695.

Contact: Advanced Logic Research, Inc., 9401 Jeronimo, Irvine, CA 92718, (800) 444-4257; in California, (714) 581-6770.

Inquiry 1141.

continued

Say Goodbye to Thermal Paper

The JetFax works with your LaserJet-type printer for laser-printer clarity.

It connects directly to your phone line through the standard copper cable, and you plug it into the printer through the printer's parallel port. It operates at the standard Group 3 rates of up to 9600 bits per second and can receive up to 30 pages with its one-half megabyte of internal memory.

If the printer is active when your JetFax begins to receive a facsimile, your JetFax will store the incoming message and will print it after the initial print job has concluded. With a full megabyte of RAM, you can store up to 60 fax pages, as well as use the higher-resolution mode of many laser printers. The memory also serves as a printer-sharing device for PCs, or a file server on a local-area network.

You can also add an economy fax machine to send faxes and to handle any overload. **Price:** \$1195; with 1 megabyte of RAM, \$1395. **Contact:** Hybrid Fax, Inc., 1733 Woodside Rd., Suite 335, Redwood City, CA 94061, (415) 369-0600. **Inquiry 1148.**

Wallet-Size Hard Disk Drive

The Hardpac Micro 20 is an 8-ounce, 20-megabyte hard disk drive featuring an access time of 28 milliseconds and a shock rating of 100 g's.

Features include a hard disk drive access mechanism that's 30 percent the size of standard 3½-inch disk drives, ramped heads, automatic parking, and a 1.5-watt power



Print out those faxes on a LaserJet.

requirement.

You need a half-slot XT or AT host adapter for desktops, or any Amstrad laptop or Toshiba Model 1100.

Price: \$1195; host adapters are all \$95.

Contact: Aristotle Industries, Inc., 3226 Beta Ave., Burnaby, BC, Canada V5G 4K4, (604) 294-1113.

Inquiry 1151.

Printer Redefines Portability

The Toshiba Express-Writer 301 portable printer features a 24-pin print head in a 4-pound package.

Maximum speed is only 60 characters per second. Graphics resolution is 180 by 180 dots per inch, and the maximum paper width is 8½ inches. Normal speed is 42 cps, and it prints best on thermal transfer paper.

Memory is 2K bytes of RAM, and it includes a nickel-cadmium battery.

Price: \$489. **Contact:** Toshiba America, Inc., Information Systems Division, 9740 Irvine Blvd., Irvine, CA 92718, (800) 457-7777; in California, (714) 583-3000.

Inquiry 1149.

And, for Your Portable Mac

The WriteMove is a 192-dpi ink-jet printer that will fit inside your Macintosh's carrying case. WriteMove weighs 3 pounds and measures 2 by 7 by 11 inches.

QuickDraw imaging technology hardware is coupled with multiple software features, including six fonts, your choice of printer drivers, a spooler, an installer, and a print-manager application.

You can scale the fonts to any size or rotate, condense, expand, or manipulate them like PostScript-compatible fonts. You can also reduce documents to 25 percent and enlarge them to 400 percent in 1 percent increments, while retaining 192 dpi.

The driver allows for several printing options. For example, Preview lets you view the document on-screen before printing; Draft prints less than 192 dpi for quicker output; High-Quality ensures 192 dpi; and Print Later permits batching of print jobs for printing later with the print manager application.

Price: \$699. **Contact:** GCC Technologies, 580 Winter St., Waltham, MA 02154, (617) 890-0880.

Inquiry 1150.

Hard Disk Drives For LAN Servers

A series of hard disk drives intended for use in PC LAN server applications has been designed by Plus Development.

The Impulse series includes 40- and 80-megabyte drives and a proprietary 16-bit bus interface card. You can install up to four of the half-height 3½-inch drives inside a PC and attach up to 14 in external chassis that hold two drives each, for a total of up to 16 drives, or 1.3 gigabytes, connected to a single card.

You can install two cards in a PC backplane; under DOS and OS/2, you can access up to 24 drives. Under Novell's NetWare, 32 drives, or 2.6 gigabytes of storage, can exist on the server, the company says.

Plus offers the Impulse models as an alternative to 150- to 350-megabyte server drives. The advantage is that with Impulse, you can expand server capacity incrementally, in chunks of 40 or 80 megabytes. Plus says the system, with multiple disk units, can achieve a degree of parallel data access. Although all data eventually has to pass sequentially through the interface card and onto the bus, the drive heads can rotate and seek simultaneously.

Plus has enhanced this distributed architecture with a proprietary disk controller that the company says achieves data throughput at roughly four times the speed of a SCSI port. The cluster-disk interface transfers data 512 bytes at a time.

Price: \$995 to \$1379. **Contact:** Plus Development Corp., 1778 McCarthy Blvd., Milpitas, CA 95035, (408) 434-6900.

Inquiry 1152.

continued

FREE
Statistics I
Applications Pack
 when you order MathCAD 2.0
 between January 1 and
 February 28, 1989.

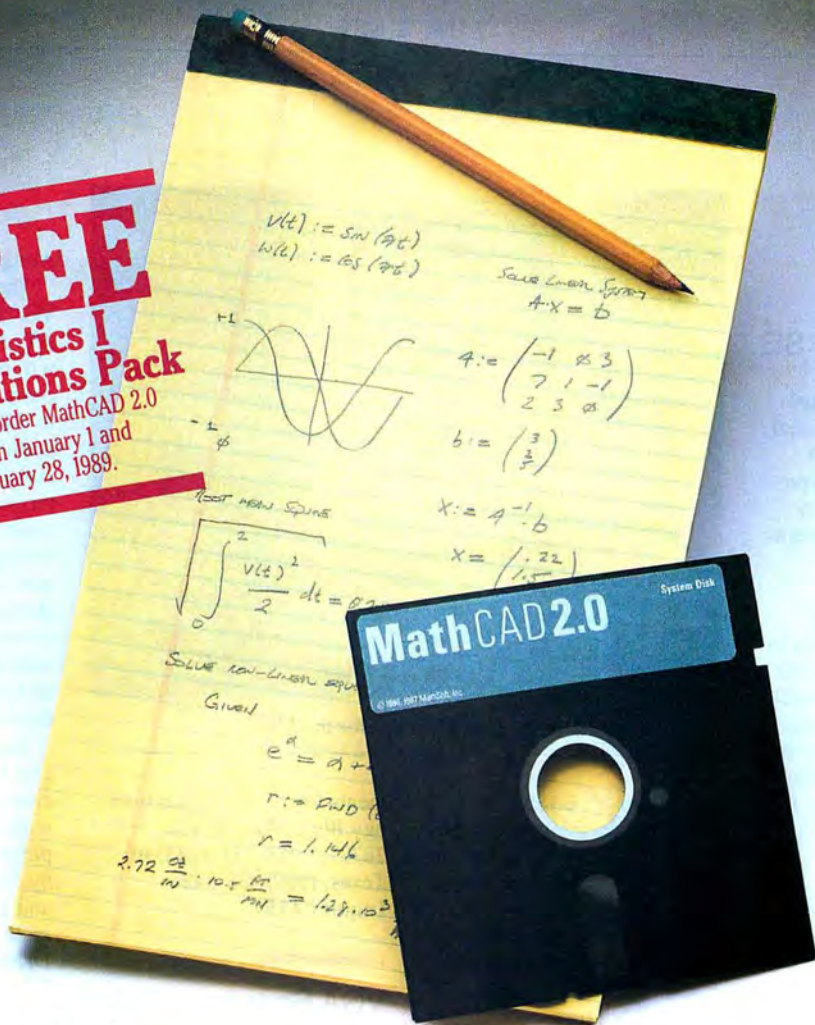

Your pad or ours?

If you perform calculations, the answer is obvious.

MathCAD 2.0.

It's everything you appreciate about working on a scratchpad—simple, free-form math—and more. More speed. More accuracy. More flexibility.

Just define your variables and enter your formulas anywhere on the screen. MathCAD formats your equations as they're typed. Instantly calculates the results. And displays them exactly as you're used to seeing them—in real math notation, as numbers, tables or graphs.

MathCAD is more than an equation solver. Like a scratchpad, it allows you to add

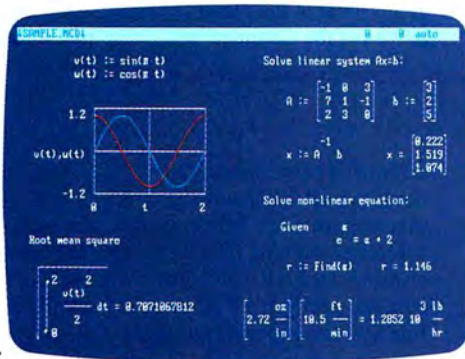

text anywhere to support your work, and see and record every step. You can try an unlimited number of what-ifs. And print your entire calculation as an integrated document that anyone can understand.

Plus, MathCAD is loaded with powerful

built-in features. In addition to the usual trigonometric and exponential functions, it includes built-in statistical functions, cubic splines, Fourier transforms, and more. It also handles complex numbers and unit conversions in a completely transparent way.

Yet, MathCAD is so easy to learn, you'll be using its full power an hour after you begin.

What more could you ask for? How about three new applications packs to increase your productivity?

The **Advanced Math Applications Pack** includes 16 applications like eigenvalues and eigenvectors of a symmetric matrix, solutions of differential equations, and polynomial least-squares fit.

Two Statistics Applications Packs let you perform 33 standard statistical routines such as multiple linear regression, combinations and permutations, finding the median, simulating a queue, frequency distributions, and much more.

MathCAD lets you perform calculations in a way that's faster, more natural, and less error-prone than the way you're doing them now—whether you use a calculator, a spreadsheet, or programs you write yourself. So come on over to MathCAD and join 45,000 enthusiastic users.

See your dealer or call **1-800-MATHCAD Ext. 2776** (In MA: 617-577-1017).

Requires IBM PC® or compatible, 512KB RAM, graphics card.
 IBM PC® International Business Machines Corporation.
 MathCAD® MathSoft, Inc.

MathCAD®

MathSoft, Inc., One Kendall Sq., Cambridge, MA 02139

Data Acquisition Reaches the Mac SE

The Lab-SE data acquisition board from National Instruments features A/D conversion with software-programmable gain, on-board timing, flexible channel scanning, and full interrupt capability.

It contains an 8-bit A/D converter with eight analog inputs and a 125-kHz sampling rate, a 13-bit integrating A/D converter (12 bits and a sign-bit), two 8-bit D/A converters with voltage outputs, 24 lines of TTL-compatible digital I/O, and three 16-bit on-board counter/timer channels.

Each Lab-SE comes equipped with a 5½-inch ribbon cable that connects the card from inside the SE to a 50-pin male ribbon connector that mounts on the back of the SE. The Lab-SE also needs the software driver with routines that are callable from any language that supports system Toolbox device manager calls. The software driver includes language interfaces for MPW C, Lightspeed C,



National Instruments' Lab-SE board for the Mac.

and Microsoft BASIC.

For the complete graphical programming environment for developing scientific and engineering applications, you need LabView, a graphical programming language, the Lab-SE, and the Lab-SE driver. With them, you can develop application programs to control the SE board.

Price: Data acquisition board, \$595; software driver, \$95; LabView, \$1995 (with significant academic discounts available).

Contact: National Instru-

ments Corp., 12109 Technology Blvd., Austin, TX 78727, (800) 531-4742; in Texas, (800) 433-3488.

Inquiry 1154.

VGA Board Generates NTSC-Compatible Signals

With the Recordable VGA graphics board, IBM PC owners can afford to attain some of the video capabilities of the Commodore

Amiga and Atari ST.

The US Video Recordable VGA board for the IBM PC, XT, AT, and compatibles will output NTSC-standard composite video in real time to TV monitors and VCRs. To do this, it performs two functions: It acts as a VGA interface to high-resolution color monitors (and offers performance 400 percent to 600 percent faster than basic VGA, the company claims), and it converts computer graphics to video that can be recorded and played back on any standard videotape recorder.

Each board supports several high-resolution modes, including 640 by 480 pixels with 256 colors, 800 by 600 pixels with 16 colors, 1024 by 768 pixels with 16 colors, and 132-column text modes in 25, 30, 43, and 60 rows. Drivers for AutoCAD, PCAD, Ventura Publisher, Lotus 1-2-3, and WordPerfect are included.

While the Recordable VGA promises 100 percent NTSC compatibility, US Video readily admits that its system cannot remove flicker. But the company says that by using VGA's large palette of colors to shade lines, the flicker from Recordable VGA is "no worse than what you see on TV."

One enhancement module is available, with two others in the works, the company says. The overlay module, which includes genlock functions, combines a computer-generated image with an external video source in a video-recordable format.

Price: \$785; overlay module, \$385.

Contact: US Video, One Stamford Landing, 62 Southfield Ave., Stamford, CT 06902, (203) 964-9000.

Inquiry 1157.

continued

Adding MIPS with Chips

When you add the 260 Personal Mainframe or the 270PM to your IBM XT, AT, PS/2 Model 30, or Model 35, you also add as much as 10 million instructions per second (MIPS) of processing power. And you provide a Unix System V operating system to work alone or concurrently with your system's native DOS.

Both the 260PM and the 270PM are based on the 32532 processor from National Semiconductor. The 260PM operates at 25 MHz and offers 8.5-MIPS performance, claims manufacturer Opus Systems. Simi-

larly, the company claims that the 270PM operates at 30 MHz and offers 10-MIPS performance.

That means, Opus says, when a 270PM is added to a 25-MHz cached 80386-based system that operates at 5 MIPS, the resulting system totals 15 MIPS and is a dual-processing system. The 260PM and 270PM dominate much of the I/O processing, but not all.

Both the products offer a version of the MIT X Window System and the 32381 floating-point processor to support single- and double-precision IEEE-format

arithmetic calculations. Optionally available is software that supports an Ethernet controller running TCP/IP; similar TCP/IP software bundled with Sun's Network File System; and application software written in C, FORTRAN 77, COBOL, Common Lisp, BASIC, and others.

Price: 260PM with 4 megabytes of RAM, \$6995; 270PM with 4 megabytes of RAM, \$7995.

Contact: Opus Systems, 20863 Stevens Creek Blvd., Building 400, Cupertino, CA 95014, (408) 446-2110.

Inquiry 1153.

Through Basic training? Graduate to Turbo Pascal.

Turbo Pascal® is easy to learn, fast, powerful, and the most popular Pascal compiler in the world.

When you graduate from Basic to Turbo Pascal, you have entirely new freedoms and powers. Modern, modular programming for one. Basic doesn't support that. Complete control over your computer's memory is another. Basic doesn't give you that.

Turbo Pascal's .EXE files are streamlined and fast, just like the pros'. And Pascal doesn't promote Basic flaws like "GOTO" that lead to spaghetti code.

None of which matters as much as the spectacular difference Turbo Pascal makes to the size and speed of your programs. Basic is big and slow. Turbo Pascal is just the opposite.

You'll like Turbo Pascal 5.0's environmental impact

With Turbo Pascal, you're in a completely integrated environment that includes source-level debugging. You can step code, watch expressions, change variables and set breakpoints. Edit, compile, run and debug.

You are not alone

We're here to help—whether on CompuServe, by phone to Tech Support or through User Groups. Borland revolutionized programming languages, made Pascal the worldwide favorite, and we're committed to supporting you. Our manuals and tutorials—unlike most others—are clear, concise, and thoroughly professional.

We also offer an extended family of Turbo Pascal Toolbox programs including source code: Runtime Library, Database Toolbox, Graphix Toolbox, Turbo Pascal Tutor, Editor Toolbox, Numerical Methods Toolbox, and GameWorks. Borland is the Pascal one-stop shop.

60-Day Money-back Guarantee.*

*Customer satisfaction is our main concern. If within 60 days of purchase this product does not perform in accordance with our claims, call our customer service department, and we will arrange a refund. **Includes upgrade manual plus disks for just \$49.95 (plus tax for CA and MA residents, and \$5.00 for handling within the U.S., \$10.00 in Canada). All Borland products are trademarks or registered trademarks of Borland International, Inc. Other brand and product names are trademarks or registered trademarks of their respective holders. Copyright ©1988 Borland International, Inc. BI-1285

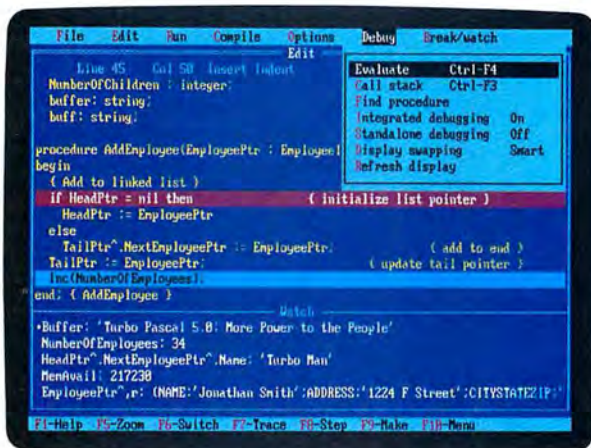

The integrated development environment lets you easily write and debug real programs.

Turn pro for only \$250 with new Turbo Pascal Professional

This special package—Turbo Pascal Professional—includes everything you need for professional programming in Pascal.

- New Turbo Pascal Version 5.0
- New Turbo Debugger®
- New Turbo Assembler®

Turbo Debugger, recent recipient of PC Magazine's Technical Excellence Award in the development tools category, lets you debug *any* size program

and have up to 12 views of your code. Turbo Assembler is much faster than MASM and more compatible with MASM than MASM is with itself. Turbo Pascal Professional: it's nothing but the best.

A fast look at 5.0

- Fully integrated development environment
- New source-level debugger
- 34,000 lines a minute on PS/2 Model 60
- RAM-resident context-sensitive Help
- .EXE files bigger than 64K
- Demand Overlays
- EMS support
- Separate compilation by Units

Forget the Basics for only \$149.95

Ready to move onward and upward from Basic? You can make easy entry to Pascal with 5.0 for only \$149.95.

And if you're a current Turbo Pascal 4.0 user, you can upgrade to the new version 5.0 for \$49.95.**

To upgrade only call (800) 543-7543, or for the dealer nearest you, call (408) 438-5300.



B O R L A N D

Circle 38 on Reader Service Card (DEALERS: 39)





ScanMan™. Turning imaginations loose everywhere.

It's time to let loose and buy a ScanMan.

Pop any image up to 4.2" x 14" straight into any IBM PC, PS/2, or compatible, selecting one, two, three, or four hundred dpi resolution.

Then use our PaintShow Plus™, which comes with your ScanMan, to crop, rotate, and resize the image—just how you want the finished version to look. If you have a color printer, enhance your masterpiece with PaintShow's colorful palette.

You can import the image into virtually any best-selling application, from desktop publishing to presentation graphics and word processing. All for only \$299, or \$349 for the Micro Channel version, complete with easy instructions, and Logitech's full warranty and support.

Now just imagine the 1,001 ways you could cheer up all your publications and reports.

For your nearest dealer call:

800-231-7717

*In California:
(800) 552-8885*

*In Europe: ++41-
21-869-96-56*

Mac and Clipboard are trademarks of Apple Computer.



Circle 135 on Reader Service Card (DEALERS: 136)

Bus Mastering Debut on Token Ring

The first available add-in board that is configured as a bus master controller comes from Mexican technology and American marketing, according to Lantana Technology. Lantana is the marketing-driven company that recently opened shop in the U.S. to import and sell technology that was originally developed in Mexico by Computadoras Micron S.A. de C.V.

The Cypress/2 board is a 16-bit token-ring add-in board for IBM PC-compatible 4-megabit-per-second token-ring networks. The bus-mastering feature, the most advanced feature of the PS/2 Micro Channel bus, allows the main system processor to give up control of the system bus temporarily so that a processor on an expansion card can use it for high-speed data transfers.

In addition to the bus-mastering feature, the Lantana boards include 128K bytes of RAM that expands the buffer and allows the IEEE 802.2 logical link control software to



Lantana's Cypress/2 16-bit token-ring add-in board.

be loaded, a 32K-byte EPROM module that stores the LLC software in ROM, and a remote-program-load EPROM module for diskless workstations.

Price: \$795.

Contact: Lantana Technology, Inc., 4393 Viewridge Ave., Suite A, San Diego, CA 92123, (619) 565-6400.

Inquiry 1164.

IBM Cranks Up Token Ring to 16 Megabits

The token-passing technology that IBM popularized in its 4-megabit-per-second local-area network is now available in IEEE 802.3-compliant hardware support-

ing 16-Mbps data rates. This pits IBM in the networking arena against the companies offering products that conform to the 10-Mbps IEEE-specified Ethernet networks.

At the heart of the new add-in boards is an IBM-designed CMOS A/D interface chip. The Micro Channel board can be switched between 4 and 16 Mbps to upgrade existing token rings. The 16-Mbps AT board cannot be switched. Neither board includes bus-mastering capabilities.

All the new adapter cards provide 64K bytes of RAM instead of the 8K-byte or 16K-byte RAM on previous boards. When used in the file servers of 4-Mbps LANs, IBM says, the boards increase the number of workstations that can

share server resources.

Price: \$895.

Contact: Consult your local IBM branch office or call (800) 426-2468.

Inquiry 1165.

Modem Links Ethernets Using Broadband

The 10Broad36 LanExpress modem from Lanex lets you run two or eight Ethernet local-area networks (LANs) on the same coaxial cable.

The IEEE 802.3 broadband standard means multiple LANs on one cable (with different frequencies). Baseband Ethernet is more widespread, yet it allows only one LAN (one frequency) per coaxial cable.

The modem performs the same function over a broadband LAN that Ethernet transceivers do for a baseband LAN, without affecting the baseband-controller hardware or software. In other words, the 10Broad36 replaces baseband Ethernet transceivers, the most popular of the Ethernet transceivers.

Both the two-port and the eight-port LanExpress models connect Transmission Control Protocol/Internet Protocol nodes over a 10-megabit-per-second Ethernet broadband backbone. They also connect such multi-protocol devices as DECnet, NetWare, XNS, TCP/IP, and Open Systems Interconnection over the same coaxial cable.

Price: Two-port, \$2695; eight-port, \$2895.

Contact: Lanex Corp., 10727 Tucker St., Beltsville, MD 20705, (800) 638-5969; in Maryland, (301) 595-4700.

Inquiry 1162.

continued

Hayes Integrates PAD on the Modem

By incorporating a packet assembly/disassembly (PAD) function on a ROM chip in its X.25 modem, Hayes Microcomputer Products will provide PC users with multisession, multipoint communications through X.25 telecommunications. (PAD units enable equipment not designed for packet switching to access a packet-switched network.)

You can also use X.25 to establish a direct data connection at 2400 bits per second to any of the Integrated Services Digital Networks. With this modem, multisession,

multipoint communications will mean you can make one standard telephone call to a telephone network that offers CCITT's X.25 and turn that connection into four data connections to PCs and mainframes alike. Then you hotkey from one data connection to another.

Value-added networks like Telenet, Tymnet, MCI, and Datapac (in Canada) already offer X.25 packet-switching services. Packet-switched information is less expensive than circuit-switched information. This is because it travels in pack-

ets and therefore isn't continuous, as it must be on traditional telephone networks.

Hayes says these modems will probably be used for managing terminals and workstations in dispersed locations. They could be used for multisession, multipoint communications.

Price: \$895, or \$50 for a single-chip ROM upgrade package for any of the company's V-series products.

Contact: Hayes Microcomputer Products, Inc., P.O. Box 105203, Atlanta, GA 30348, (404) 449-8791.

Inquiry 1163.

Get out of the danger zone with ORACLE®



Announcing ORACLE Quicksilver

All the database Top Guns are flying SQL, the industry-standard data management language first delivered by Oracle. Now, ORACLE Quicksilver adds SQL and connectivity to your dBASE applications, so you can fly them into the 1990s.

Your ticket to the future

ORACLE Quicksilver is a compiler that turns your dBASE programs into fast, secure, multi-user applications that can access both distributed ORACLE and dBASE data. It delivers all the capabilities of dBASE, plus powerful extensions like windowing, graphics and user-defined functions. You can even add SQL statements to your dBASE programs for more powerful, flexible data access.

ORACLE database included

ORACLE Quicksilver comes with the ORACLE RDBMS. So you can get automatic indexing, comprehensive security, and mainframe-class data integrity.

Why wait until dBASE IV can talk to SQL Server?

dBASE IV doesn't talk to SQL Server yet. When it finally does, it will only talk to SQL Server on OS/2—not on any other operating system. Which means you'll still be isolated from corporate data on minis and mainframes.

Add connectivity to your dBASE applications today

Your ORACLE Quicksilver applications can talk to ORACLE SQL databases on your PC today. And with our optional networking software, you can build distributed databases across ORACLE servers on PCs, minis and mainframes—including IBM DB2 data.

No-risk Money Back Guarantee

Test fly ORACLE Quicksilver now. If you're not out of the danger zone in 30 days, return it for a full refund. **Limited Time Free Offer:** Order now and, for a limited time, you'll receive ORACLE SQL*Tutor—our on-line SQL training program—absolutely free.

Call 1-800-ORACLE1, ext. 4925 today.
Or fill out and return the attached no-risk coupon now.



Dear Oracle...

Oracle PC Direct • 20 Davis Drive • Belmont, California 94002
1-800-ORACLE1, ext. 4925

Send me the following ORACLE products for my PC.* Enclosed is my check or VISA MasterCard AMEX credit card number and authorization for:

\$ _____ ORACLE Quicksilver at \$699 and ORACLE SQL*Tutor free
\$ _____ ORACLE SQL*Tutor ONLY for \$199
\$ _____ Please add appropriate state sales tax
\$ _____ **Total enclosed/authorized.**
I understand Oracle will pay for shipping, and all prices valid in U.S. only.

NAME _____ TITLE _____
COMPANY _____
STREET (no P.O. boxes, please) _____
CITY _____ STATE _____ ZIP _____
PHONE _____
CREDIT CARD NO. _____ CARD EXPIRATION DATE _____
SIGNATURE _____ TODAY'S DATE _____ BYTE _____

*REQUIREMENTS: ORACLE SQL*Tutor: 256K PC and hard disk. ORACLE Quicksilver: To manage only dBASE DBF files and no ORACLE database, you need a 640K PC. To manage an ORACLE database on a remote computer, you need a 640K PC and optional networking software. To build an ORACLE database on your PC, you need a 286 or 386 PC with 640K plus 1MB of extended memory. All configurations require hard disks and DOS 3.0+.

ORACLE®

COMPATIBILITY • PORTABILITY • CONNECTABILITY

Call 1-800-ORACLE1, ext. 4925 today.

Copyright © 1988 by Oracle Corporation. ORACLE is a registered trademark of Oracle Corporation. Also trademarks: dBASE of Ashton-Tate, Quicksilver of Quicksilver Software, Inc. DB2, OS/2 and IBM of International Business Machines. Other companies mentioned own numerous trademarks. TRBA

20 Davis Drive, Belmont, CA 94002 • World Headquarters (415) 598-8000 • ORACLE Canada (800) 387-4407 (except Quebec) • Quebec (514) 337-0755 • ORACLE Systems Australia 61-2-959-5080 • ORACLE Europe 44-1-948-6911 • ORACLE Systems Hong Kong 852-5-266846



Sony's workstations feature high-capacity optical drives.

Sony's No-Baloney Workstation

If you've got room on your desk for an IBM PC AT, you've got more than enough room for Sony's high-powered 68030 Unix workstations with erasable optical disk drives. The NWS-1750 is based on a single 68030. The NWS-1830 and -1850 are based on two 68030s.

On one double-sided 5¼-inch cartridge, you can store 594 megabytes of formatted data. Rewriting is accomplished with a semiconductor laser and a biasing magnet to change the magnetic orientation of the cartridge's recording layer. The laser writes on the cartridge by magnetizing the cartridge's recording layer, which causes changes in the laser beam's plane of polarization.

The NWS-1750 comes standard with 4 megabytes of RAM (expandable to 32 megabytes). It also has a 286-megabyte hard disk drive. Graphics options include 14-inch, 816- by 1024-pixel

monochrome and 16- and 19-inch, 1280- by 1024-pixel four- or eight-plane color displays with a graphics controller.

The NWS-1830 and -1850 are rated at 5.3 million instructions per second based on dual 25-MHz 68030 microprocessors, a 25-MHz 68882 floating-point coprocessor, and a 64-byte cache memory. The second microprocessor on the 1800 series handles only I/O functions and can increase total system performance by 30 percent in many I/O-intensive applications, Sony says, making it particularly valuable when it's used as a file server or when tape operations are used.

All the 1800 series workstations are equipped with a 1.44-megabyte 3½-inch floppy disk drive, a 125-megabyte ¼-inch cartridge tape unit, 16 megabytes of RAM (expandable to 32 megabytes), and 286 megabytes of hard disk drive storage space.

All the 1700s and 1800s use the News-OS version 3 operating system, which is

based on Unix 4.3BSD. They also use the X Window System version 11 graphics standard from MIT.

Price: Sony's 1700 series, \$13,900 to \$51,600; the 1800 series, \$31,900 to \$54,200; NWP-539 erasable optical drive, \$4650; optical cartridge, \$250.

Contact: Sony Microsystems Co., 1049 Elwell Court, Palo Alto, CA 94303, (415) 965-4492.

Inquiry 1146.

This Time is Real

The Ohio Scientific 720 is based on the Motorola 68020 processors and a Unix-compatible operating system that is designed for real-time operating requirements.

Such real-time features as zero-wait-state system calls and Request and Event queues guarantee specific response times to external interrupts.

Through an additional level of priorities, the 720 guarantees each user some response time because the level is nonshared.

Each 720 has 12 RS-232C ports, so, through intelligent terminal concentrators and networking, the system can accommodate as many as 60 users. Additional 68020 CPUs (with supporting static RAM cache) can be added in a parallel arrangement with dynamic load balancing, the manufacturer claims.

The standard 720 includes 4 megabytes of RAM that's expandable to 64 megabytes. Hard disk capacities range from 91 megabytes to 1.2 gigabytes, totaling to 16 gigabytes.

Price: \$6350.

Contact: Consolidated Computer Systems, Inc., 2150-D West Sixth Ave., Broomfield, CO 80020, (303) 460-0444.

Inquiry 1147.

continued

A Workstation for the Laptop

The high-performance Toshiba T5100 multi-user portable workstation includes Intel's 80386 microprocessor and runs T/PIX, Toshiba's version of AT&T's Unix System V/386 with 4.2BSD extensions.

The workstation is targeted at business applications but is finding a niche with many software developers because, in its full-featured configuration, it comes bundled with T/PIX. That means there's no need to load and configure from the 25 disks Toshiba will send you to load T/PIX separately, and you can ship demo software in a compact package without much difficulty.

In its base configuration, the 16-MHz 80386 includes 2 megabytes of RAM, a 40-megabyte 29-millisecond hard disk drive, a 1.44-megabyte 3½-inch floppy disk drive, and a 640- by 400-pixel EGA-compatible gas-plasma display.

The keyboard has 82 keys, including an integrated numeric keypad; there's also a port for a 101-key keyboard so you can add your own.

Other standards are an EGA monitor controller, an RS-232C port, a combination parallel port and 5¼-inch floppy disk drive controller, and an internal expansion slot. You also get MS-DOS. The basic T5100 supports X Windows, networking through Remote File Sharing, and TCP/IP through an optional Ethernet interface.

Price: \$7199; with 2 megabytes of RAM and T/PIX, \$8750.

Contact: Toshiba America, Inc., Advanced Systems, 9740 Irvine Blvd., Irvine, CA 92718, (714) 583-3071.

Inquiry 1145.

Now, VGA Graphics for the Right Side of Your Brain.

Get the Best VGA Color and Resolution Possible: SuperVGA™ 16-Bit Graphics Adapters.

Finally, two VGA adapters that work the way your brain does. They're fast. They're bright. And they're quick to adapt.

First let's talk fast. The SuperVGA™ 16-Bit Graphics Adapters use AT-type buses—giving you twice the bandwidth of other VGA cards. Combine that with our RAMBIOS memory cache feature and you get up to *5 times* faster performance. And the adapters are smart enough to automatically switch between 8-bit PC/XT and 16-bit AT operation.

For CAD and desktop publishing, these adapters turn ordinary computers into full-

blown graphics engines. Fully loaded, they give you an unprecedented 1024 x 768 resolution in 16 bright colors—both interlaced and non-interlaced.* Or 256 brilliant on-screen colors out of a palette of 256K, in other resolutions—including 800 x 600 and 640 x 480.*

With two adapters to choose from, now you don't have to wrack your brain over VGA decisions. Because they work with virtually any monitor— analog, digital, or MultiSync. They're fully compatible with IBM®, VGA, EGA, MCGA, CGA,

MDA and Hercules standards. And they include drivers for many popular software packages. Best of all, you can start with the economical Model 5300 today, and upgrade to the full power of a Model 5400 later. You simply add 256KB of DRAM.

So before you make up your mind on graphics, brainstorm with your local dealer on SuperVGA™ 16-Bit Graphics Adapters. Call (408) 432-9090 today. Or write Genoa Systems Corporation, 75 East Trimble Road, San Jose, CA 95131, FAX (408) 434-0997, London 44-01-225-3247, Taiwan 886-02-776-3933.

* Requires 512KB VGA DRAM



Insist on
Genoan Value.
Genoa

Circle 96 on Reader Service Card

IBM PC, XT and AT are registered trademarks of IBM Corp. Hercules is a trademark of Hercules Technology. Adaptron is a trademark of Adaptron. SuperVGA is a trademark of Genoa Systems Corp.

Now Peter Norton

If you've ever seen the words "GENERAL FAILURE ERROR" on the screen of your PC, you know you don't need to be ill to feel sick.

All you need is a corrupted disk with some valuable data stored aboard.

When that happens, it's time to call on the remarkable new *Norton Disk Doctor*™.

The Norton Disk Doctor is one of 27 data recovery and disk management tools in the latest Advanced Edition of the Norton Utilities®.

It's also the most significant advance in utility software technology since Peter Norton first began saving the data and the derrières of grateful PC

C> FILE NOT FOUND!

Our legendary UnErase — and its short-cutting offspring Quick UnErase have saved the derrières of thousands of grateful PC users. And they're still saving them.

users around the world with the legendary — and still unequalled — *UnErase*®.

Why you need a Doctor in the house.

Now, whenever INVALID DRIVE SPECIFICATION or some other cryptic or catastrophic error message appears on your screen, you can do something besides reach for the Maalox®.

You can summon the Disk Doctor, which will

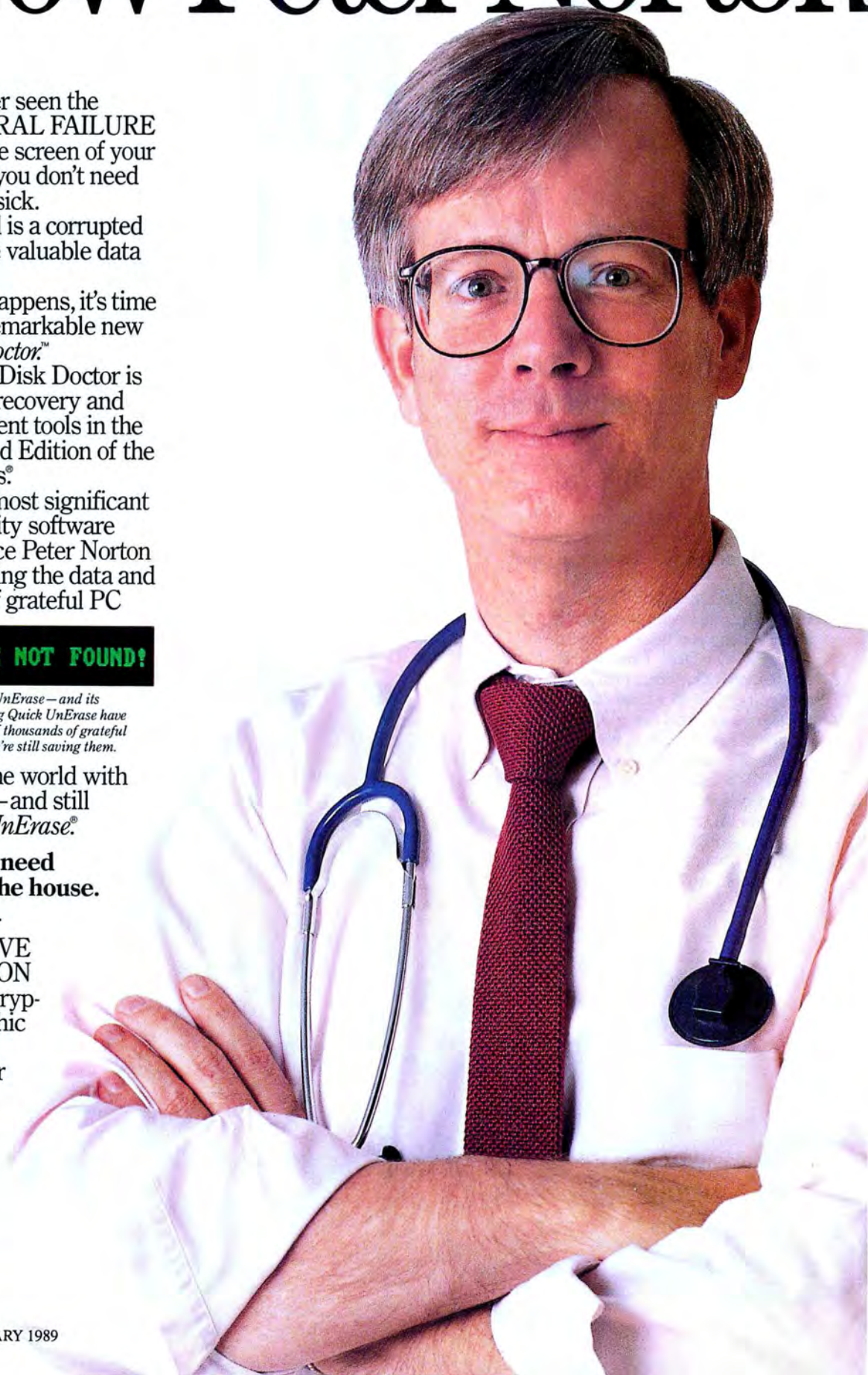

makes house calls.



determine the exact nature of the problem, report it and, in most cases, fix it for you.

All by itself.

The Disk Doctor can diagnose and repair everything from bad partition tables and boot records to mangled root directories. It can even reformat bad sectors and write back the old data.

Automatically.

In fact, if the Doctor can't cure your corrupted floppy or hard disk, then Buster, you've got one corrupt disk.

In which case, you'll need to refer to *The Norton Troubleshooter*, a 158-page guide to finding and fixing most anything that could go wrong.

Don't worry, you don't have to go to the bookstore or the library to refer to it, because the Troubleshooter is included in the Advanced Edition.

Frankly, the Norton Disk Doctor and the Norton Troubleshooter are worth the price of the new Advanced Edition all by themselves.

But, of course, they aren't by themselves.

They're accompanied by a wish list of features, functions and enhancements sufficient to satisfy the yearnings of all those people who've been politely writing and calling to request them.

The people's choices.

Like *Speed Disk*, the world's most powerful disk tuning tool, which features four user-selectable optimization methods and doesn't lose your data if you lose power.

And *Format Recover*, which can unformat your accidentally reformatted hard disk even if you haven't taken any precautions beforehand.

Our user interface, which *InfoWorld* said made the Utilities "as easy to use as possible," now comes with pop-up windows and dialog boxes.

Our new *Norton Control Center*™ lets you define or alter a range of system settings—from cursor size to screen and palette colors—quickly and easily.

While our *Disk Test* finds and marks faulty areas on your disk to help you protect your data before you have a chance to lose it.

If you want to lose it, however, you'll be glad to know that *WipeFile*™ and

WipeDisk™ support DoD 5220.22-M 116b(2), the Pentagon's latest data security specification.

Which means they'll erase your files so thoroughly not even Peter Norton can find them.

You'll find the latest Norton Utilities at your favorite software dealer.

If you haven't got a favorite software dealer, take two aspirin, call us right away at 1-800-365-1010 and place an order.

The Doctor will be on its way in no time.

Peter Norton

COMPUTING

All Utilities now support large hard disks under DOS 4.0, COMPAQ DOS 3.31, and the PC-MOS/386 multi-tasking operating system. Designed for the IBM® PS/2® and PC families and 100% compatibles. © 1988 Peter Norton Computing, Inc. 100 Wilshire Blvd., 9th Floor, Santa Monica, CA 90401-1104



The Norton Disk Companion is included, free, with both the Standard and Advanced Editions. The Norton Troubleshooter is yours with the Advanced Edition.

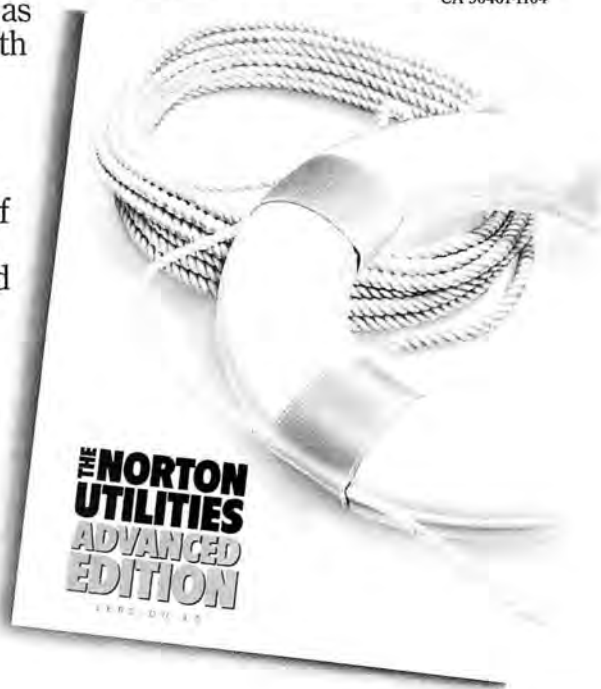

QuickBASIC Gives Quick Help

Microsoft's latest incarnation of its venerable QuickBASIC programming language—version 4.5—features a new hypertext-based on-line help system. Dubbed "Advisor," it lets you instantly call up cross-referenced information from the language's entire reference manual. If you're a newcomer to programming, Advisor will help you learn BASIC more quickly; if you're an experienced hacker, it'll let you quickly find more esoteric information. The key to Advisor is a help engine. Taking up just 5K bytes of RAM, it includes a file manager, a text decompressor, and utilities.

QuickBASIC's Advisor lets you put the cursor on any word on the screen and get detailed information. For instance, if you're entering a line of BASIC code and want to know more about the IF statement, you place the cursor on IF, press a help key, and get the full reference to the IF statement. Microsoft says it will be integrating Advisor technology into upcoming releases



QuickBASIC's Advisor is a hypertext help system.

of its other programming languages.

Besides the new help technology, QuickBASIC 4.5 has the same features as version 4.0. They include a smart syntax-checking editor and compilation speeds of up to 150,000 lines per minute. There's also an improved source-level debugger with what Microsoft calls an "instant" watch capability.

QuickBASIC 4.5 runs on the IBM PC, XT, AT, PS/2s, and compatibles with 384K bytes of RAM, MS-DOS 2.1 or higher, and a graphics adapter. It supports the Microsoft Mouse and comes with

printed reference and tutorial manuals.

Price: \$99.

Contact: Microsoft Corp., 16011 Northeast 36th Way, P.O. Box 97017, Redmond, WA 98073, (206) 882-8080.

Inquiry 1108.

Tools for the Turbo Pascal Trade

Written in Pascal, the AIS Programmer ToolKits let you manipulate windows, enter and edit data, design screens, and more in the Turbo Pascal Integrated Envi-

ronment. The ToolKits are compatible with Turbo Pascal versions 3.0 through 5.0 and contain several modules, including the Editor ToolKit, Screen Design Utilities, a Window ToolKit, a Dynamic Array ToolKit (for version 4.0), a Linked List ToolKit, and a Printer ToolKit.

Complete Pascal source code is included with the AIS Programmer ToolKits. To run the development package, you'll need an IBM PC, XT, AT, PS/2, or compatible running any Turbo Pascal version 3.0 through 5.0.

Price: \$44.95.

Contact: Abaire Information Services, Inc., 2302 Ginter St., Richmond, VA 23228, (804) 262-2966.

Inquiry 1109.

Presentation Manager Development Tool

If you're an application developer using Presentation Manager, Object/1 may be the tool for you. Using object-oriented programming techniques, it offers a forms painter, a database interface, and CASE development tools.

The forms painter lets you create list boxes, radio buttons, and other graphical elements. You can create user interfaces such as pop-up menus, links from list boxes to database fields, and enforced integrity on data input.

The development tool includes source code along with hundreds of example classes, methods, and objects. It runs on 80286- or 80386-based systems with at least 4 megabytes of RAM.

Price: Approximately \$900.

Contact: Micro Data Base Systems, Inc., P.O. Box 248, Lafayette, IN 47902, (800) 344-5832; in Indiana, (317) 463-2581.

Inquiry 1110.

A Little Jewel Makes Logical Connections

One of the trickiest problems for any programmer is correctly coding multibranch logic modules. Writing the code for constructs like nested IF... THEN statements can be both challenging and time-consuming. But Sterling Castle has a new program called Logic Gem that takes the headache out of the process, letting you concentrate on the problem instead of writing code for the solution.

You can think of Logic Gem as doing for logic what a spreadsheet does for num-

bers. Structured very much like a spreadsheet, it's an electronic decision table that the company claims eliminates the possibility of bugs.

Logic Gem is actually a collection of three decision-table tools: an editor, an interpreter, and a code generator. The editor automatically completes an incomplete logic table for you, generating a set of decision rules. It also eliminates redundant or contradictory rules. Then the interpreter steps you through the table to verify the logic. Finally, the code

generator translates the complete decision tables into program code.

Logic Gem produces code in C, structured BASIC, interpretive BASIC, Pascal, FORTRAN, dBASE, and English.

The program runs on any IBM PC or compatible and needs 640K bytes of RAM.

Price: \$198.

Contact: Sterling Castle, 702 Washington St., Suite 174, Marina del Rey, CA 90292, (800) 722-7853; in California, (800) 323-6406.

Inquiry 1107.

continued

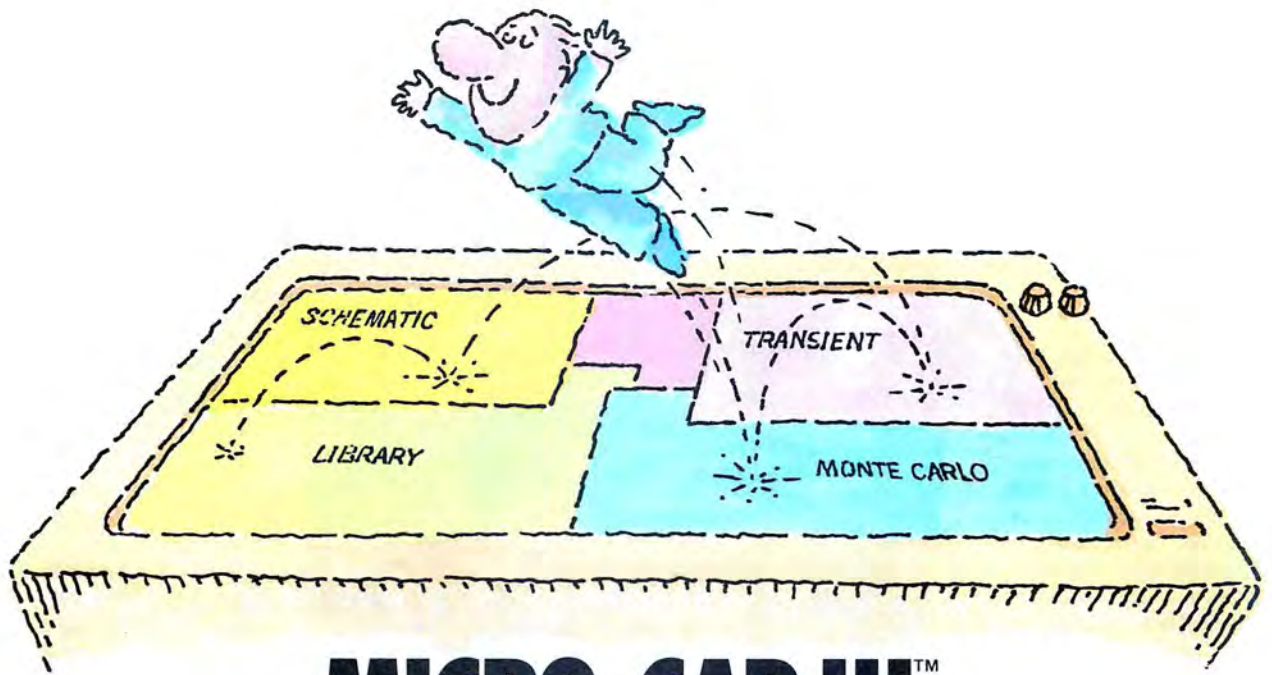

MICRO-CAP III.™ THIRD-GENERATION INTERACTIVE CIRCUIT ANALYSIS. MORE POWER. MORE SPEED. LESS WORK.

MICRO-CAP III,™ the third generation of the top selling IBM® PC-based interactive CAE tool, adds even more accuracy, speed, and simplicity to circuit design and simulation.

The program's window-based operation and schematic editor make circuit creation a breeze. And super-fast SPICE-like routines mean quick AC, DC, Fourier and transient analysis — right from schematics. You can combine simulations of digital and analog circuits via integrated switch models and macros. And, using stepped component values, rapidly generate multiple plots to fine-tune your circuits.

We've added routines for noise, impedance and conductance — even Monte Carlo routines for statistical analysis of production yield. Plus algebraic formula parsers for plotting almost any desired function.

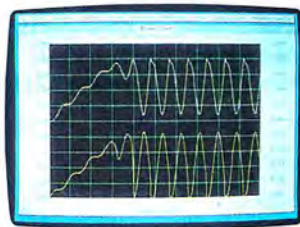

Transient analysis

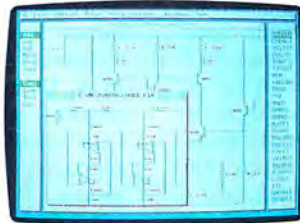

Schematic editor

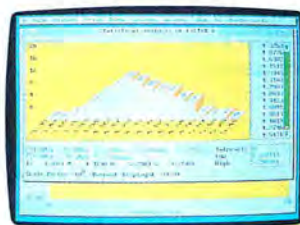

Monte Carlo analysis

Modeling power leaps upward as well, to Gummel-Poon BJT and Level 3 MOS — supported, of course, by a built-in Parameter Estimation Program and extended standard parts library.

There's support for Hercules®, CGA, MCGA, EGA and VGA displays. Output for laser plotters and printers. And a lot more.

The cost? Just \$1495. Evaluation versions are only \$150.

Naturally, you'll want to call or write for a free brochure and demo disk.

spectrum

1021 S. Wolfe Road,
Sunnyvale, CA 94086
(408) 738-4387

MICRO-CAP III is a registered trademark of Spectrum Software.
Hercules is a registered trademark of Hercules Computer Technology.
IBM is a registered trademark of International Business Machines, Inc.

Low-Cost CAD

Foresight Resources has spruced up its Drafix CAD and renamed it Drafix CAD Ultra.

One of the enhancements is a CADapult utility, which lets you take attribute information and convert it to a variety of databases, spreadsheets, and high-level language formats. Then you can bring the information back into Drafix CAD Ultra.

The program also lets you use its Hewlett-Packard Graphics Language export command to save plotting instructions in formats compatible with desktop publishing programs such as Aldus Page-Maker and Ventura Publisher. You can also import ASCII text files from word processing programs and use the text in your CAD drawings.

Also included with the program is a library of over 450 predrawn symbols. Separate libraries of architectural, mechanical engineering, and electrical engineering symbols are available. Other enhancements include off-line plotting and new plotter drivers that let you use D- and E-size plotters. The user interface is enhanced with the addition of status displays of layer, line-type, and pen identification. You can also backtrack through up to 100 drawing commands. The new Drafix CAD supports a wider variety of graphics adapters.

Drafix CAD Ultra runs on the IBM PC with 640K bytes of RAM, DOS 2.0 or higher, a graphics card, and a mouse. **Price:** \$395; Report writer, \$150; Professional Symbol Libraries, \$200 each.

Contact: Foresight Resources Corp., 10725 Ambassador Dr., Kansas City, MO 64153, (816) 891-1040. **Inquiry 1113.**

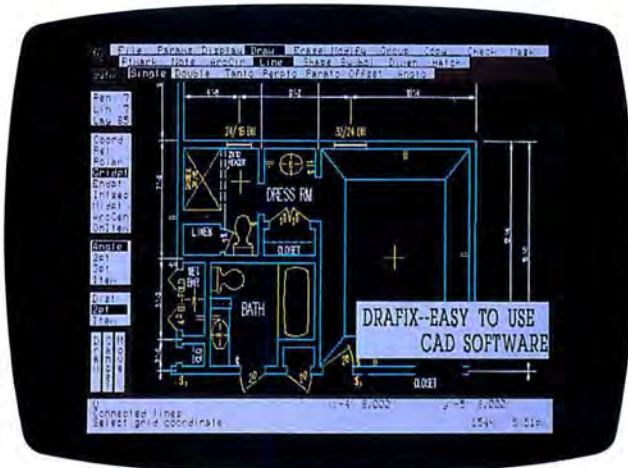

Drafix CAD now has import/export capabilities.

Souped-Up Statistical Analysis

SPSS has dropped copy protection and added new features to the statistical analysis program SPSS/PC+ Version 3.0 now lets you use 500 variables instead of the 200 in previous versions. Also added is an exploratory data-analysis procedure that produces univariate statistics and a variety of plots.

Network support is also enhanced. Previous versions supported Novell LANs, and the current version supports token-ring and 3Com networks as well.

SPSS/PC+ 3.0 runs on the IBM PC, XT, AT, and compatibles with 512K bytes of RAM and DOS 2.0 or higher.

Price: \$795. **Contact:** SPSS, Inc., 444 North Michigan Ave., Chicago, IL 60611, (312) 329-3300.

Inquiry 1114.

Tango Totally Revamped

The Tango family of electronic-design software has been completely rewritten, according to Accel Technologies. Tango-PCB Series II enhancements include user-definable tracks, pads, vias, and text strings. There are more layers, improved grid options, and a wider range of video and printer/plotter support.

The previous version allowed only four fixed track sizes, 22 pad types, and eight text-string sizes. Now you can have any number of track widths, seven pad shapes, and text strings of from 4 to 1020 millimeters. Also increased is the number of layers—up to 19 from the

previous 9. The maximum workspace is increased from 32 by 19 inches to 32 by 32 inches.

Series II now supports VGA, Hercules, and other graphics cards, in addition to CGA and EGA, which were supported in the previous version.

All functions for editing, plotting, and photoplotting are bundled into one program. New features include user-definable arcs on any layer. Component pattern libraries are also larger.

The new user interface, called the Accel Productivity Interface (API), features pop-up menus and dialog boxes. It also has a Speed

Go with the (Hydraulic) Flow

Hydronet is a fluid-analysis program that is used in applications such as water supply and treatment, petroleum transport, industrial and process engineering, wastewater conveyance, and fire-protection systems. The program computes the steady-state flows and pressures throughout systems.

The program is upgraded with a Lotus 1-2-3-type interface, display and printer graphics that show hydraulic grade lines, fitting and valve usage, critical pressure and pump calculations, and a larger system-design capacity.

The program runs on the IBM PC, XT, AT, or compatibles with 512K bytes of RAM.

Price: \$495. **Contact:** Engineering Software, P.O. Box 1450, Nevada City, CA 95959, (916) 288-3470. **Inquiry 1117.**

continued

Palette, which you can use for the commands you need most.

An auto-router is also added to the Tango-PCB Series II. The four-layer, 25-mil-grid, multipass auto-router offers pop-up menus and dialog boxes for setting up design parameters.

To run the Tango-PCB Series II products, you need an IBM PC or compatible with a CGA, VGA, EGA, or Hercules graphics card. **Price:** PCB alone, \$595; PCB with Route, \$995.

Contact: Accel Technologies, Inc., 7358 Trade St., San Diego, CA 92121, (619) 695-2000. **Inquiry 1115.**

GET OUR FREE 28-PAGE CATALOG OF DELL COMPUTER SYSTEMS.

This new catalog is the best place to shop for high-performance 386™ systems, 286 systems, and more. At the lowest possible prices. Just send this card, and we'll send you a copy. Or call (800) 426-5150. In Canada, call (800) 387-5752.

Name: _____

Title: _____

Company: _____

Address: _____

City: _____ State: _____ Zip: _____

Phone: _____

Please have a Dell representative call me.

1. Which products are you most interested in?

- A 286-based systems
B 386-based systems
 Other _____

2. How many PCs do you (your company) plan to purchase in the next twelve months?

- A 1-10
B 11-20
C Over 21

3. Is your requirement:

- A Immediate
B 1-3 months
C Over 3 months
D Info only

4. Are you a (select one):

- A End User
B Consultant
C Reseller
D Corporate Purchaser
E DP/MIS

5. How many PCs do you have installed now?

- A 1-10
B 11-20
C Over 21



©1988 DELL COMPUTER CORPORATION. 386 is a trademark of Intel Corporation.

AD CODE NO. 51EB9



NO POSTAGE
NECESSARY
IF MAILED
IN THE
UNITED STATES

BUSINESS REPLY MAIL

FIRST CLASS MAIL PERMIT NO. 6745 AUSTIN, TEXAS

POSTAGE WILL BE PAID BY ADDRESSEE

DELL COMPUTER CORPORATION
DEPT. ME
9505 Arboretum Boulevard
Austin, Texas 78759-9969



WHY YOU SHOULD BUY COMPUTERS BY THE BOOK.

As you can see from our 4-page ad at the front of this magazine, buying direct from Dell is the best possible way to buy computers. And this book is the best way to order. The Dell Computer Catalog. In 28 pages, it gives you full information on our high-performance 386™ systems, 286 systems, laser printers, and much more.



Besides our own equipment, you'll also find a full line of software, peripherals, accessories, enhancement products, and networking solutions. All at lower-than-retail prices with higher-than-retail service and support. Just call us at (800) 426-5150. In Canada, call (800) 387-5752. Or send the attached reply card. And we'll send a catalog immediately.

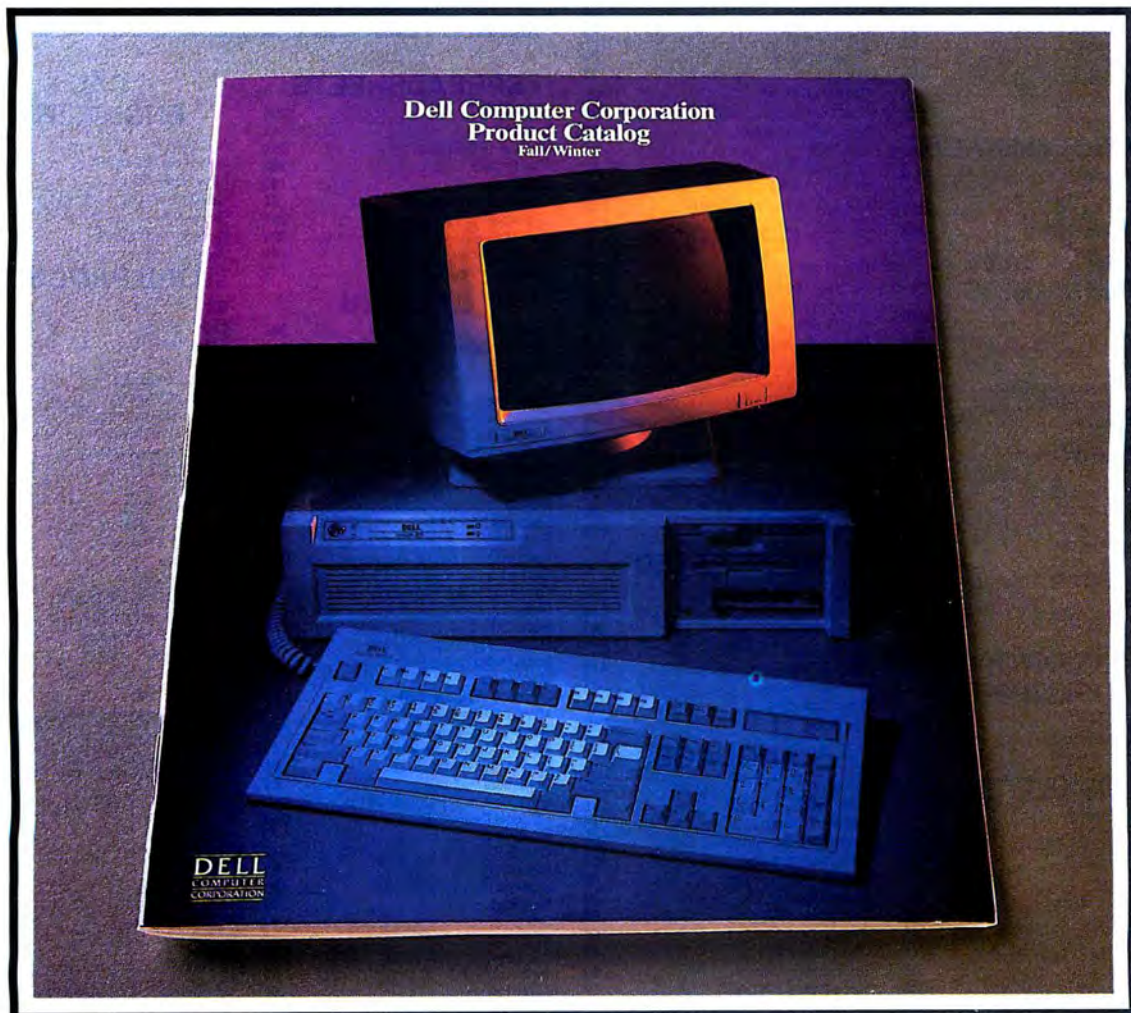

©1988 DELL COMPUTER CORPORATION. 386 is a trademark of Intel Corporation.

AD CODE NO. 11EB9

WAREHOUSE DATA PRODUCTS

**SAVE
60%
ON OUR
EVERYDAY
PRICES**

SINCE 1979, servicing our PC buyers with low pricing, technical experience – and reliable service.

S O F T W A R E

ACCOUNTING

Dac Easy Acct, Ver 3.0	\$55
Dac Easy Light	39
Dollars & Sense	94
Managing Your Money 5.0	Call
One Write Plus	143
Peachtree Business Accounting	149
Peachtree W/PDO	220
Quicken	29

COMMUNICATION PROGRAMS

Brooklyn Bridge Universal	Call
Carbon Copy Plus	\$105
Crosstalk XVI	92
Crosstalk MK4	110
Desklink	99
Flying Dutchman	64
Lap Link Plus	75
PC Anywhere III	69
Relay Gold 3.0	140
Smartcom III	145

PROJECT MANAGER

Microsoft Project	\$299
Super Project Plus	255
Timeline Pro Ver. 3.0	323
Total Harvard Manager 3	369

DATA BASE MANAGERS

Clipper	\$410
Condor 3	325
DataPerfect	283
D Base IV	Call
D Base IV Programmers Edition	799
DB-XL Diamond 1.2	115
Fox Base Plus 2.1	190
Genifer	189
Knowledgeman 2	285
Paradox 2.0	Call
PFS: Professional File 2.0	Call
Powerbase 2.3	169
Q&A 3.0	188
QuickSilver Diamond 1.2	329
Revelation Advanced	450
R Base For DOS	425
Reflex	90
Relate & Report	112
VP Info 2.0	Call

DESKTOP PUBLISHING

Pagemaker Ver. 3.0	Call
PFS: First Publisher 2.0	Call
Ventura Publisher 2.0	Call

DISKETTES

Maxell 5 1/4" DS/HD	\$24
Maxell 5 1/4" DS/DD	11
Polaroid Diskettes	Call
3M 5 1/4" DS/HD	20
3M 5 1/4" DS/DD	15
3M 600A Data Tapes	28
3M Tape Cartridges	Call
Verbatim 252D	10
Verbatim 25HD	18
Verbatim 3.5 720K	18
Verbatim 3.5 1.4M	43

DOS

IBM 4.0	\$120
MS-DOS 4.0	Call

EDUCATIONAL

Mavis Beacon Teaches Typing	Call
Microsoft Learning DOS	\$30
Turbo Tutor II	49
Typing Tutor IV	30

ENTERTAINMENT

Chuck Yeager Flight Simulator	\$35
F15-Strike Eagle	24
Gunship	35
Hacker II	30
Jet	39
Kings Quest	30
Kings Quest IV	30
Microsoft Flight Simulator 3.0	33
Scenery Disk 1-7	17 ea.
Silent Service	30
Speller Bee w/voice	50
Star Flight	40
Sub Battle	30
Where in the World	29
Many More Titles Available	Call

GRAPHICS

Chartmaster	\$199
Diagram Master	199
Energraphics 2.0	199
First Graphics	Call
Harvard Graphics 2.1	Call
In-A-Vision	298
Mapmaster	219
Microsoft Chart 3.0	225
Newsroom	31
Newsroom Professional	65
Printmaster Plus	29
Printshop	33
Printshop Companion	29
Print Shop Holiday	20
Signmaster	132

INTEGRATED

Ability	\$56
Ability Plus	Call
Enable OA	352
First Choice	Call
Framework III	418
Microsoft Works	83
Smart Software	Call
Symphony	Call

LANGUAGES

Microsoft C 5.1	\$255
Microsoft Quick Basic	59
Microsoft Quick C	Call
Ryan McFarlan Fortran	390
Ryan McFarlan Cobol	612
Turbo Basic	59
Turbo C 2.0	90
Turbo Pascal 5.0	90
Turbo C Pro	162
Turbo Pascal/Pro	162
Turbo Prolog 2.0	90
Turbo Prolog Toolbox	59

COMPUGUARD™

ANTI-VIRUS™

The Advanced PC Security Product!
Protect your PC against Virus Attacks

\$89

• Malicious Programs • Vandalism • Revenge
• Destruction of Files • Time Bombs • Loss of Data

Don't Wait Until It Hits You!!

SPREADSHEETS

Lotus 1-2-3	\$295
Lucid 3D	Call
Microsoft PC Excel	Call
Plan Perfect	168
Quattro	143
Spreadsheet Auditor	82
SuperCalc 5	Call
Surpass	329
Twin Advanced	69
VP Planner Plus	117

UTILITIES

Allways	\$85
Battery Watch	Call
Copy II PC	19
Copywrite	39
Core Fast	75
Cubit	39
D.A.V.E.	55
Desqview 2.2	Call
Direct Access	49
Duet	48
Eureka	99
Fastback Plus 2.01	104
Formtools	56
Formworx	Call
Gopher	39
Graph in the Box Release 2	73
Grasp	79
Hot	89
HTEST	69
Lotus Metro	69
Mace Gold	79
Microsoft Windows 286	55
Microsoft Windows 386	110
Norton Advanced 4.5	Call
Norton Commander 2.0	45
Norton Utilities 4.5	48
Numerical Methods	59
Org Plus Adv	Call
PC Tools Deluxe 5.0	Call
Prokey 4.0	70
QDOS II	49
Rightwriter	53
Sidekick Plus	120
Sideways	39
S.O.S.	44
SQZ Plus	55
Super Key	59
Turbo Lightening	56
XTree Pro	64

CAD & ENGINEERING

Autosketch	Call
DesignCad 2D or 3D	\$148
EasyCad 2.05	109
FastCad	1435
Generic Cad	49
Generic Cad Level 3	Call
MathCad 2.0	245

WORD PROCESSING

Borland Sprint	\$122
Easy Extra	54
Grammatik III	49
Grandview	169
Lotus Manuscript	319
Microsoft Word 5.0	Call
Multimate Advantage II	259
Overlay Word Perfect	Call
PFS Professional Write	Call
SPF/PC 2.0	165
Varsity	49
Volkwriter 3	139
Webster Spellcheck Pro	33
Webster Thesaurus	39
Will Maker	34
Gopher	39
Word Perfect 5.0	219
Word Perfect Executive	124
Word Perfect Library 2.0	65
Wordstar ProPack 5.0	239
Wordstar 2000 Plus	205
Wordstar 2000 Plus Legal	Call
Xywrite III Plus	Call

**CALL
FOR ITEMS
NOT LISTED.**

2727 W. Glendale Ave.
Phoenix, AZ 85051
1-800-421-3135
1-602-246-2222

WAREHOUSE DATA PRODUCTS
Division of AZ Computer Corporation
2727 W. Glendale Ave. • Phoenix, AZ 85051

**Call on Novell and any other
networking products**

1-800-421-3135

We gladly assist the first time buyer as well as the professional systems analyst. Call our toll-free technical service at 1-800-421-3135.

H A R D W A R E

ARC PRO TURBO 88

- 640K 4.77/9.54 MHz
- Color Mono Graphics Card
- 84 Key Keyboard
- 2 - RS-232 Serial Port
- 1 - Parallel Printer Port
- 1 - Clock Calendar
- MS DOS 3.3

w/Monochrome Monitor \$809
w/Color Monitor 969

ARC PRO TURBO 286

- 512K RAM 8/12 MHz
- EGA/MDA Graphics Card
- 101 Key Keyboard
- 2 - RS-232 Serial Ports
- 1 - Parallel Printer Port
- 1 - Clock Calendar
- MS DOS 3.3

w/Monochrome Monitor \$1279
w/Color Monitor 1439
w/EGA Monitor 1559

ARC 386 Skyscraper Call

ACCESSORIES

Copy II PC Deluxe Board \$101
Curtis Ruby Plus 69
Keytronic Keyboards Call
Logical Connection Call
Mach III Joystick 36
Masterpiece 85
Masterpiece Plus 95
NTC 101 Keyboard 69
Stedi-Watt 65
150 Watt Power Supply 69

BOARDS

AST Advantage Premium 512K \$429
AST I/O Mini XT 52
AST Rampage/2, 512K Call
AST Rampage 286 Plus, 512K Call
AST Sixpac Plus w/64K 129
AST Xformer Call
Everex RAM 2000 79
Everex RAM 3000 89
Everex Magic Card 16
Everex Multi Function EMS Call
Everex Magic I/O Call
Hercules Graphics Plus 179
Inboard 386 PC Call
Intel Above 286, 512K Call
Microsoft Mach 20 287
Orchid Tiny Turbo 289

CO-PROCESSOR

INTEL
80287 Call
80287-8 Call
80287-10 Call
80387-20 Call
80387SX Call
8087-2 Call
8087 Call

LASER PRINTERS

AST Turbo PS \$3199
Okidata Laser 6 w/IF 1519
Panasonic 4450 Call
Toshiba Page Laser Call

LAPTOP COMPUTERS

Sharp Laptop Call
Toshiba T-1000 \$799
Toshiba T-1200FB 1569
Toshiba T-1299HB 2419
Toshiba T-3200 3799
Toshiba T-5100 4895
Toshiba T-3100E Call
Toshiba T-5200 Call
Toshiba Accessories Call
Zenith Laptop Call

VIDEO BOARDS

AST VGA Plus \$349
ATI EGA Wonder 800 229
ATI VGA Wonder Call
EVEREX VGA EV675 249
Genoa 5200 Call
NEC 1024 Call
Orchid Designer 800 249
Orchid Pro Designer 299
Orchid Pro Designer Plus Call
Paradise Autoswitch EGA Call
Paradise VGA Plus Call
Paradise VGA Proff. 385
Vega V RAM Call

AT&T

AT&T 6300 WGS, 10MHz \$899
AT&T 6286 WGS, 12MHz 1499
AT&T 6386 WGS, 16MHz 2199
AT&T 6386, 20MHz, 135 MB H.D. 4599
AT&T 6386E, 20MHz, 135 MB H.D. Lan Server Tower 5399

UPS

Emerson
UPS 200 Call
UPS 300 Call
UPS 800 Call
UPS 1500 Call

EGA MONITORS

Goldstar EGA w/Swivel Call
Mitsubishi Diamond Scan Call
NEC - Multisync II Call
Princeton Ultra 16 Call
Princeton Ultra Sync Call
Samsung CM 4531 \$369
Samtron Multisync 449
Sony Multiscan Call
Zenith Call

FLOPPY DRIVES

Teac 5 1/4" 360K \$79
Toshiba 3 1/2" 1.44 MB 129
Toshiba 3 1/2" 720K 109

HARD CARDS

Plus Hardcard 20 MB \$529
Plus Hardcard 40 MB 659
Plus Passport 20 MB Call
Plus Passport 40 MB Call
TMG Cardrive 20 329
TMG Cardrive 30 349
TMG Cardrive 50 515

HARD DRIVES

Bernoulli 44MB Call
Bernoulli B1201 \$779
Bernoulli B120X Call
Bernoulli B220X Call
Core Hard Drives Call
Miniscribe 20 MB 249
Priam Call
Seagate 20 MB w/Cont 259
Seagate 30 MB w/Cont 279
Seagate 60 MB Call
Seagate PS/2 25,30 Call
Seagate ST 125 w/Cont 319
Seagate ST 138 w/Cont Call
Seagate ST 251 349
Seagate ST 4096 585

MODEMS

Everex 300/1200 \$69
Everex 2400 INT 139
Everex 2400 MNP INT 159
Everex 2400 MNP EXT 189
Everex Mini 1200 Call
Hayes 1200 Call
Hayes 2400 Call
Holmes 1200 INT Call
Holmes 2400 INT Call
U.S. Robotics 2400E Call
U.S. Robotics 9600 HST Call
U.S. Robotics Courier 2400 Call
U.S. Robotics Sportster 1200 Call
U.S. Robotics Sportster 2400 Call

DIGITIZERS

Kurta Tablets Call
Summa Graphics Call

MICE/SCANNERS

Complete Scanners \$178
Datacopy Call
HP Scanjet Call
Logitech Clear Call
Logitech HiRes Call
Logitech PS/2 Call
Logitech Scanman Call
Logitech Serial 68
Microsoft Bus w/Paintbrush 92
Microsoft Serial w/Paintbrush 92
Panasonic FX-RS 505 Call

MONITORS

AMDEK 410 \$145
Goldstar Amber w/Swivel 79
Magnavox RGB 255
NEC GS Amber Call
NEC Monograph w/Card Call
Princeton Max 12 138
Princeton Max 15 Call
Samsung TTL Amber 76
Samsung Flat 89
Samsung RGB w/tilt 249
Sigma Lazerview Call
Viking
Viking I 869
Viking 10 Color 2369
Viking 2400 1289

PRINTERS

ALPS
Allegro 24 Call
CITIZEN
120 D \$146
180 D 165
MSP 40 285
MSP 45 415
MSP 50 385
Tribute 124 455
EPSON - Call on all models
NEC Products Call
OKIDATA - Call on all models
OKI320/321 Call
OKI390 Call
OKI391 Call
OKI393 Call
PANASONIC
1080-I/M2 169
1091-I/M2 Call
1092-I 329
1124 Call
1524 Call
1592 409
3131 329
STAR MICRONICS
NX1000 179
NX1000 Color 238
NX15 306
NX2400 Call
TOSHIBA
321 SL Call
341 SL Call
351 SX Call
P311 Call

FREE SOFTWARE!

Purchase over \$100 and receive one of these disks absolutely FREE! Purchases over \$250 get two free disks, over \$400 get three, or get all four disks when your purchase is over \$500!

- 1) MIXED BAG. 2) PC-WRITE.
- 3) FONT-SET. 4) DR. DATA LABEL.

WE CARRY TARGUS LAPTOP BAGS Call

WAREHOUSE DATA
PRODUCTS

No Charge for
MasterCard or Visa



TERMS

Shipping on most software is \$5.00. AZ orders + 6.7% sales tax. Personal/company check allow fourteen (14) days to clear. We accept purchase orders from authorized institutions for 3.5% more than cash price. All returns are subject to our approval. There will be a 20% restock fee. All prices are subject to change. Due to copyright laws we cannot take back any open software.

Circle 245 on Reader Service Card (DEALERS: 246)

Phone Hours: Monday thru Friday 6:30 a.m. - 9:00 p.m. MST
Saturday 9:00 a.m. - 5:00 p.m. MST

Technical Support: 1-800-421-3135
Call our 1-800-421-3135 within the USA and Canada.

- All Prices are subject to change.
- We do not guarantee compatibility.

We stock all available products.

Quotron Opens Windows

A new set of software that operates in the Microsoft Windows environment lets Quotron PC users integrate their Quotron financial information services with other applications.

QuotData, QuotChart, and QuotTerm make up the Open Windows family. QuotData lets you create databases of Quotron real-time market data that you can use with other software. QuotChart is a charting and technical-analysis program that is fed by the QuotData application. QuotTerm is a terminal-emulation application that gives you access to Quotron financial information services while viewing other applications on the PC.

The Open Windows products are available individually or bundled as one package.

To run QuotChart and QuotData you need an 80286 or 80386 DOS-based PC with at least 2 megabytes of RAM, a hard disk drive, one serial communications port, one bus mouse, an EGA card, DOS 3.0 or higher, and Windows/286 or 386 version 2.0 or higher. To run QuotTerm, you need at least 640K bytes of RAM, one serial communications port, one bus or serial mouse, DOS 3.0 or higher, and Windows/286 or 386 version 2.0 or higher.

Price: Monthly charges per workstation: QuotChart, \$300; QuotData, \$250; QuotTerm, \$100. One-time charges: Open Windows installation, \$500; Excel and Windows/386, \$350.

Contact: Quotron Systems, Inc., 12731 West Jefferson Blvd., Los Angeles, CA 90066, (213) 827-4600. **Inquiry 1126.**

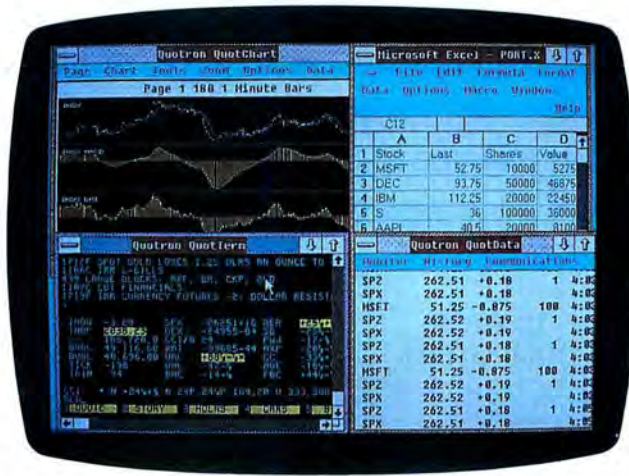

Quotron's windows of financial data.

Present Yourself

From Genesis Data Systems comes the Rapid Prototyping System (RPS): software that helps you design, prototype, and present your ideas.

The system contains three modules: a screen designer, a music designer, and a prototyper. Also included are a memory-resident screen-capture utility, a music utility, and a run-time utility.

The screen-design module offers 16 foreground and background colors, or 16 foreground and eight background colors with blinking counterparts. You can use the memory-resident module to capture screens from other programs. You can also add overlays and animation.

The module's editing capabilities let you edit, move, or duplicate selected areas of the screen. You can use macros and Undo and Redo Undo commands. You also have the ability to customize lettering.

The music module uses standard music notation for composing or duplicating music. The range includes eighth notes to whole notes, and you can use dotted or tied rests. You have a selection of four tempos, and you can build key signatures, repeats, and refrains. You can save tunes to a disk file to play in the background of presentations, either from the DOS prompt or through instructions you create with the prototyping module.

You use the prototyping module to pull the screens and music together into presentations. It features variable commands, branching instructions, and real-time pauses.

RPS runs on the IBM PC, XT, AT, PS/2s, and compatibles with 256K bytes of RAM and DOS 2.0 or higher. It supports color, monochrome, or TTL monitors. **Price:** \$249.95.

Contact: Genesis Data Systems, 8415 Washington Place NE, Suite A, Albuquerque, NM 87113, (800) 777-1437; in New Mexico, (505) 821-9425.

Inquiry 1122.

continued

Simple, Fast, and Cheap Word Processing

ZEdit is what its developer calls a front-end word processor. What does it mean? Mainly, that ZEdit is a fast, small, and surprisingly versatile package that admittedly isn't designed to be everything to everyone. Telecom Library admits that ZEdit is "lacking in print sophistication," but if you want to spruce up ZEdit's files with fancy formatting, you can load them into any word processor, because they're plain-vanilla ASCII.

ZEdit takes up just 52K bytes of RAM, and Telecom Library says that makes it ideal for floppy disk drive-only laptop computers or for

applications where you want to load a major application on top of ZEdit. And because ZEdit and the documents that you're working on stay in RAM, response time is fast. You can even preload documents into remaining RAM—as many as you have room for.

The package also lets you have up to eight windows open on the screen at once, with each window having either a different file or a different view of the same file. This gives you the unique ability to simultaneously edit the beginning, middle, and end of the same document. You can also move

data between any open windows, not just between adjacent ones.

You can configure ZEdit to emulate the key commands of any word processor you're already familiar with. It also features pull-down menus, mouse support, and a built-in keyboard macro facility.

To use ZEdit, you'll need an IBM PC, XT, AT, PS/2, or compatible.

Price: \$59.95.

Contact: Telecom Library, Inc., 12 West 21st St., New York, NY 10010, (800) 999-0345; in New York, (212) 691-8215.

Inquiry 1121.



WHEN THEIR CUSTOMERS DEMANDED UNIX SYSTEM V SOLUTIONS, THESE INDUSTRY LEADERS CAME TO SCO

Standards are made, not born.

The leading UNIX® System on three generations of PCs, SCO™ XENIX® System V has revolutionized the way people look at both the UNIX System and PCs by revealing the amazing hidden potential of these standard hardware platforms.

In the process, SCO XENIX has become a true standard in UNIX System V software.

And like a true standard, SCO XENIX has opened up entire new markets of opportunity that have never before existed for micro-processor-based computers.

Teamed with the latest generation of 80386-based machines, SCO XENIX 386 allows systems created from the widest range of hardware choices to surpass the multiuser, multitasking performance of minis or even mainframes—at a fraction of the cost.

SCO XENIX can be found running thousands of XENIX- and UNIX System-based vertical applications on powerful business systems supporting 16, 32, or even more users. And on graphics workstations running advanced engineering and scientific applications.

And, of course, on personal computers, running multiple DOS applications concurrently, or networking XENIX and DOS systems together.

Today, more and more end users are demanding the power that only UNIX System V software can bring to their standard hardware platforms.

And when leading developers, resellers, and computer manufacturers who serve these users want to make sure they're working with a partner who's the UNIX System software leader—for now, and long into the future of UNIX System standards—they come to SCO.

They know that SCO will provide them with the most comprehensive environment for UNIX System applications, technical and marketing support, training, and documentation in existence.

And they know they can trust SCO UNIX System software to be the most complete and reliable anywhere in the world, because it comes from the most complete and reliable UNIX System software company in the world.

The UNIX System software leader—SCO.



The UNIX System Software Leader Worldwide

(800) 626-UNIX (626-8649) • (408) 425-7222 • FAX: (408) 458-4227 • TWX: 910-598-4510 SCO SACZ • E-MAIL: ...!uunet!sco!info info@sco.COM

UNIX is a registered trademark of AT&T. SCO and the SCO logo are trademarks of The Santa Cruz Operation, Inc. XENIX is a registered trademark of Microsoft Corporation. ©1988 The Santa Cruz Operation, Inc., 400 Encinal Street, P.O. Box 1900, Santa Cruz, CA 95061 USA. The Santa Cruz Operation, Ltd., Crossley Centre, Hatters Lane, Watford WD1 8YN, United Kingdom. +44 (0)923 816544. FAX: +44 (0)923 817781. TELEX: 917372 scocon g

RIX Presents VGA Graphics

The VGA paint program ColoRIX offers 256-color VGA support for the IBM PS/2 Models 50, 60, 70, and 80 in 360- by 480-pixel resolution without any hardware additions or modifications. You can manipulate those 256 colors from a palette of 256,000.

Some of the key functions included in ColoRIX are a graduation command that lets you create color graduations, a Frepal command that lets you free any of the 256 displayed colors from the color palette, a Drag command that lets you leave a multiple-image trail as you move your selected image anywhere on-screen,

and Smooth and Smudge commands.

Price: \$199.

Contact: RIX SoftWorks, Inc., 18552 MacArthur Blvd., Suite 375, Irvine, CA 92715, (800) 345-9059; in California, (800) 233-5983.

Inquiry 1135.

Processing Images with Zip

Process images, control video digitizers, and display video images with Zip, a program that controls the ImageWise video digitizer transmitter and receiver.

The program offers more than 20 image-processing functions, including convolution, histogram equalization, and linearization, that allow

you to manipulate and improve gray-scale images. You can also combine images.

Using the ImageWise digitizer, you can capture images from a video camera, VCR, or other video source in 256- by 244-pixel resolution with 64 levels of brightness.

Zip has 15 screen-display modes with three levels of zoom, color, and gray-level displays, minimum error techniques, dithers and duotones, and a VGA mode displaying 64 gray levels. You can save screen displays in PC Paintbrush and MacPaint file formats for use in desktop publishing or for further editing. And you can print outputs on dot-matrix, ink-jet, color, and laser printers. The program also produces halftones on laser printers.

The program runs on the

IBM PC, XT, AT, or compatibles with 384K bytes of RAM, DOS 2.0 or higher, and an EGA or VGA. To capture video images, you need an ImageWise digitizer/transmitter and a video camera or VCR. To display video images in 64 levels on a television monitor, you need an ImageWise receiver/display, a video monitor, and an NTSC (National Television System Committee) composite.

(The ImageWise was a Circuit Cellar project by Steve Ciarcia in BYTE, May through August 1987. It is now available through Hogware.) **Price:** Zip, \$79; ImageWise video digitizer, \$398. **Contact:** Hogware Co., 470 Belleview, St. Louis, MO 63119, (314) 962-7833. **Inquiry 1134.**

continued

How a software engineer got to captain the lunar landing module.

The Computer Museum is everything you'd expect, and a lot of things you wouldn't.

Of course, the museum contains a collection of the most significant accomplishments in the history of information processing. But it's not just a great place to see things, it's also a great place to do things.

There are over twenty interactive exhibits at The Computer Museum. You can design a car, create your own fractal landscape, or even captain the lunar landing



module on the Apollo flight simulator.

So, the next time you're in Boston, stop by The Computer Museum. You'll discover it's more than a lot of machines, it's also a lot of fun.

For more information, or to become a Museum Member, write The Computer Museum, or call (617) 423-6758.

The Computer Museum

B O S T O N
There's something in it for everyone.

300 Congress Street, Boston, MA 02210



COMPUTERS FROM IOWA SURPASS ALL OTHERS!

We at Gateway 2000 firmly believe that we are the best source for computers in the nation. We have over 2000 configurations available, all priced incredibly low and all backed by our unsurpassed service.

"We are very happy that our system is at the top of the stack in both price and performance, but it is your courteous service that is uncontested by the competition."

— Pierce Haviland — Kingston, NY

"Overall, I feel that your product is outstanding and your service has been excellent."

— Eric Engren — Stonington, CT



16 Mhz 286 EGA

- 1 Meg 70NS Ram
- 0 Wait State (S.L. 17.3)
- 1.2 Meg 5 1/4" Drive
- 1.44 Meg 3.5" Drive
- 40 Meg Hard Drive (28 MS)
- 1 to 1 Interleave
- EVEREX EGA Board
- 14" EGA Monitor
- 1 Parallel / 2 Serial Ports
- 101 Key Keyboard
- MS DOS w/GW Basic

\$2395.00

12 Mhz **\$2195.00**

25 Mhz 386 VGA

- 1 Meg 60NS Ram
- Expandable to 8 Megs on MB
- 32 Bit Slot Open
- 1.2 Meg 5 1/4" Drive
- 1.44 Meg 3.5" Drive
- 80 Meg Hard Drive (28 MS)
- 1 to 1 Interleave
- 16 Bit VGA Board
- NEC MULTI SYNCH II
- 1 Parallel / 2 Serial Ports
- 101 Key Keyboard
- MS DOS w/GW Basic
- 80387 and Weitek Sockets
- Vertical Style Case

\$3995.00

20 Mhz 386 EGA

- 1 Meg 60NS Ram
- 1.2 Meg 5 1/4" Drive
- 1.44 Meg 3.5" Drive
- 80 Meg Hard Drive (28 MS)
- 1 to 1 Interleave
- EVEREX EGA Board
- 14" EGA Monitor
- 1 Parallel / 2 Serial Ports
- 101 Key Keyboard
- MS DOS w/GW Basic

\$2995.00

386 SX \$2695.00

(Same configuration as above)

New



Steve Apiki & Stanford Diehl
Oct. 1988, **BITE**
Review of 20 386

- "Emerging as truly exceptional..."
- "The Gateway delivers speed without sacrificing features."
- "The system ran without a glitch."
- "We were truly surprised to see a system of this caliber selling for less than \$3000."
- "When evaluating the whole package, The GATEWAY 386 surpasses all the others!"

Circle 95 on Reader Service Card



Gateway 2000 • P.O. Box 2000 • Sgt. Bluff, IA. 51054

800-233-8472 / 712-943-2000

All systems have a 30 day Money Back Guarantee and 1 Year Warranty.
Due to the Volatility in the DRAM Market all prices subject to change.

CMO...Your Nationwide Source



PC-TOO 10MHz XT®

BASIC SYSTEM CONFIGURATION:

- 8088-10 Based System Board
- 4.77/10 MHz CPU Speed
- 640KB RAM Standard. Expandable to 1640K
- 3-In-1 Video Adapter - RGB, Mono, Comp.
- Microsoft MS-DOS & GW-BASIC Included
- Real Time Clock Calendar
- System Reset Switch
- Floppy Disk Drive Controller
- 360K Floppy Drive
- 4 Half-Height Peripheral Slots
- 8 Expansion Slots
- 102-Key Enhanced Keyboard
- Parallel/Serial/Game Ports
- 150 Watt Power Supply

\$699

Call For Information On Other
PC-TOO's (10 AT & 20MG 386)

ATARI

Atari	
800XL 64K Computer	\$ 69
130XE 132K Computer	149
XF551 Disk Drive (XL/XE)	189
Access	
Leaderboard Golf	22
Accolade	
Hardball	19
Avant Garde	
PC Ditto (IBM Emulation)	64
FTL	
Dungeon Master	29
Indus	
GTS-100 3½" ST Drive	189
Sub-Logic	
Flight Simulator II	33
Soft Logik Corp.	
Publishing Partner	59
Supra	
30MB ST Hard Drive	659
Timeworks	
Desktop Publisher	89



**ATARI 800XL & XF551
Disk Drive & Software
\$259***

*Includes: 800XL, 551 Drive &
Star Raiders, Missile Command,
Asteroids, Defender, & Qix
WordPerfect Corp. \$159
WordPerfect

AMIGA

Aegis Development	
Animator/Images	\$ 89
Draw Plus 2000	159
Sonix	49
Cinemaware	
Rocket Ranger	39
Electronic Arts	
Deluxe Photo Lab	99
Deluxe Video 1.2	89
Epyx Software	
XJ-500 Joystick	15
Gold Disk Software	
Professional Page	259
Micro Illusions	
Photon Paint	69
Micro Systems Int.	
Raw Copy V1.3	44
Micro Systems Software	
Excellence	189
New Tek Inc.	
Digi-View 2.0	149
Digi-Paint	44
Sub-Logic Corp.	
Flight Simulator II	39
WordPerfect Corp.	
WordPerfect	189

MACINTOSH

Olympia	
NP-30 Mac 150cps	289
Seikosha	
SP-1000AP Mac	239
Everex	
EMAC 20 Deluxe 20MB	595
EMAC 60T 60MB Backup	895
PCPC	
21MB SCSI Hard Drive	759
Cornerstone	
SinglePage Display SE	899
DualPage Display SE	1699
Magnavox	
9CM080 14" VGA Display	519
RasterOps	
1948S Trinitron	3395
Sigma Designs	
PageView SE	849
LaserView II	1899
New Image Technology	
MacScan Pro Sheetfeed	1399
MacScan Pro Flatbed	1789
Practical Peripherals	
Mac 2400 Stand Alone	239
Shiva	
NetModem V2400	479

MONITORS

Amdek	
Video 210 Amber	89
Video 410 TTL Monochrome	145
Color 732 VGA Color	399
Magnavox	
7BM623 12" TTL Amber	79

CM8762 14" Comp/RGB	\$249
9CM053 14" HiRes EGA	369
9CM062 14" VGA Display	359
NEC	
JC-1402 Multisync	589
Packard Bell	
PB-1272 12" TTL Mono	79
PB-1472 14" TTL 132 Col.	109
PB-1422EG 14" HiRes EGA	359
Princeton Graphics	
Max-12e 12" TTL Amber	149



**ZENITH
ZCM-1490 14" VGA
\$619**

Seiko Instruments	
CM-1430 14" VGA	649
Taxan	
770+ MultiVision Display	529

MULTIFUNCTION

ATD-ZuckerBoard	
Color Half Card	79
Monochrome Graphics Adpt.	79
AST	
Six Pak Plus Board	149
VGA Plus Adapter	389
Boca Research	
TopHat 128K Expansion	129
BocaRam/AT 0-4MB Board	149
Boca MultiEGA	189
DCA	
Irma 2 3278 Board	749



**VIDEO 7
FastWrite
\$369**



Your Source for Hardware, Software & Peripherals

For Quality Computer Products.

Everex	
Magic I/O AT Par/Ser	\$ 59
Ram 3000 Deluxe 0-3MB Bd.	89
Micro Enhancer EGA	169
5th Generation	
Logical Connection 256K	479
Hercules	
Graphics Card Plus	179
IDEAssociates	
IDE-5251 Local Emulation	579
Intel	
AboveBoard 2 Plus w/OK	319
AboveBoard PS/286 w/512K	419
Inboard 386/PC 80386 CPU	869
8087 IBM PC/XT CoP.	99
80287-8 IBM XT 8MHz CoP.	239
Orchid Technology	
ProDesigner VGA	329
Paradise	
AutoSwitch EGA 480 Adpt.	Call
Video 7	
Vega VGA Adapter	285

STORAGE DEVICES

ATD-ZuckerBoard	
Tandy 30MB HardCard	479
Everex	
Floppy Stream 40 40MB Int.	359
Excel Stream 40T 40MB Int.	529
Miniscribe	
8425 20MB 3 1/2" 40Msec	259
3650 40MB 5 1/4" 61Msec	349
Mountain Computer	
TD-4340 40MB Int. Tape	319
TD-4440 40MB Ext. Tape	459
Plus Development	
20MB HardCard	549
Seagate	
ST-225 20MB w/cont	269
ST-238 30MB w/cont	289
Sysgen	
Bridge-File 5 1/2" External	249
SmartImage 60MB Internal	479
QIC-File 60MB External	599

COMPUTERS

AST	
Premium 286 Model 80	1499
Compaq	
Deskpro 286/386 Desktops	Call
Portable 286/386	Call
NEC	
Multimate Laptops	Call
PC-TOO	
512K 8MHz 80286 Desktop	899
Sysgen	
ProSystem 12MHz w/40MB	1999
Toshiba	
T1000 8088 Laptop	Call
T1200 Floppy/HrdD Lptp	Call
Zenith	
80286/386 Desktops	Call
SuperSport Laptops	Call

COMMUNICATIONS

Anchor	
6480 C64/128 1200 Baud	99
520 ST520/1040 1200 Baud	129
1200 Baud External	109
Atari	
XMM301 XL/XE 300 Baud	44
SX-212 ST Modem	89
Avatex	
1200 HC External	99

This Month's Featured Product:



EPSON FX-1050
132 Column, 264 CPS Printer **\$444**

2400 Baud External	\$179
ATD-ZuckerBoard	
2400 Baud External	129
Everex	
Evercom 24 2400 Internal	149
Evercom 24E+ 2400 Bd. Ext.	199
Hayes	
SmartModem 1200 Baud	289
SmartModem 2400 Baud	439
Intel	
2400B Classic Internal	249
Murata	
M1200 Facsimile	779
Practical Peripherals	
1200 Baud Stand Alone	109
2400 Baud Stand Alone	189
Sharp	
FO-220 Facsimile Machine	1099
Supra	
2400AT 2400 Baud Atari	169
U.S. Robotics	
1200 Baud Direct Ext.	109
2400 Baud Direct Ext.	199

PRINTERS

Brother	
M-1709 240cps, 132 Col.	479
HR-20 20cps Daisywheel	369
HR-40 40cps Daisywheel	639



EPSON LQ-850
24-Wire, 80 Col.
\$499

Epson	
LX-800 180cps, 80 Col.	189
FX-850 264cps, 80 Col.	Call
LQ-500 180cps, 24-Wire	Call
LQ-950 264cps, 24-Wire	Call
LQ-1050 330cps, 132 Col.	Call
NEC	
P2200 Pinwriter 24-Wire	349
P5200 Pinwriter 265cps	579

Okidata	
ML-182+ 180cps, 80 Col.	\$249
ML-320 300cps, 80 Col.	359
ML-390 270cps, 24-Wire	519
Panasonic	
KX-P1080i 144cps, 80 Col.	169
KX-P1091i 194cps, 80 Col.	189
KX-P1124 192cps, 24-Wire	349
Star Micronics	
NX-1000 RainBow Color	239
NX-2400 24-Wire, 80 Col.	369
Toshiba	
P321-SL 216cps, 24-Wire	499

SOFTWARE

Ashton-Tate	
dBase IV	499
MultiMate Advantage II	289
Borland	
Paradox R-Database	449
Quattro	159
Central Point	
PC Tools Deluxe	49
Computer Associates	
AccPac Easy Accounting	79
DAC Software	
DAC-EASY Accounting	59

5th Generation	
FastBack Plus	\$ 99
IMSI	
OptiMouse w/Dr. Halo III	79
Logitech	
C7 Mouse w/Software	79
ScanMan Scanner	219
Lotus Development	
Lotus 1-2-3	299
MECA	
Managing Your Money	119
Meridian Technology	
CarbonCopy Plus 5.0	119
Microsoft	
Serial or Buss Mouse	109
Peter Norton	
Advanced Utilities	79
Peachtree	
Complete Accounting	169
Quarterdeck	
DESQView 2.02	79
Software Publishing	
1st Choice 3.0	89
1st Publisher 2.0	79
Professional Write 2.0	179
The Complete PC	
HandScan For PC	179
Complete Answer Machine	269
WordPerfect Corp.	
WordPerfect 5.0	219
Xerox	
Ventura Publishing 2.0	499



MSC
OMNIMOUSE
\$49



Your Source for Hardware, Software & Peripherals

In U.S.A.

800-233-8950

In Canada call: 800-233-8949

All Other Areas call: 717-327-9575 Fax call: 717-327-1217

Educational, Governmental and Corporate Organizations

Call toll-free: 1-800-221-4283

CMO, 101 Reighard Ave., Dept. A1, Williamsport, PA 17701

Over 400,000 SATISFIED CUSTOMERS • MAJOR CREDIT CARDS ACCEPTED

POLICY: Add 3% (minimum \$7.00) shipping and handling. Larger shipments may require additional charges. Personal and company checks require 3 weeks to clear. For faster delivery, use your credit card or send cashier's check or bank money order. Credit cards are not charged until we ship. Pennsylvania and Maryland residents add appropriate sales tax. All prices are U.S.A. prices and are subject to change. All items are subject to availability. Defective software will be replaced with the same item only. Hardware will be replaced or repaired at our discretion within the terms and limits of the manufacturer's warranty. We cannot guarantee compatibility. All sales are final and returned shipments are subject to a restocking fee. We are not responsible for typographic or photographic errors.



A102

MORE dBASE POWER!

FOR ONLY

\$189.95!



dB MAN V: A database manager for your PC that has dBASE III+ power, Report Writer, and Compiler all in one package! Now you can buy a powerful dBASE III+ work-alike that includes more features and power than any other competitive product on the market, at a fraction of the cost!

"dBMAN competes directly with dBASE III+, it runs many operations much more quickly and costs less than half the price." Bruce Brown, PC Magazine.

Unlimited Power. We extended the dBASE III+ language to bring you to a new level of programming power and versatility.

Reports without programming! With our Report Writer you can easily create invoices, sales statements, form letters, employee lists, multi-lined and columnar reports, and more. All without programming!

Speed unequalled in performance. dBMAN V's Greased Lightning! Compiler executes dBASE applications up to 16 times faster than dBASE III+, and comes with an unlimited distribution runtime license at no extra cost!

We are offering a **30 day money back guarantee** if not fully satisfied. (When purchased from a Versasoft authorized dealer.)

And, our multi-user version of dBMAN for Novell, IBM PC Net retails for only \$499.95!

Just compare our price with the competition:

Program	Interpreter	Compiler	Report Writer	TOTAL
dBMAN V	\$189.95	included	included	\$189.95
FoxBASE	\$395.00	\$495.00	\$149.95*	\$1039.95
Clipper	N/A	\$695.00	\$149.95*	\$844.95
QuickSilver	\$199.00	\$599.00	\$149.95*	\$947.95
dBASE III+	\$795.00	N/A	\$149.95*	\$944.75
dBASE IV	\$1295.00	included	included	\$1295.00

* Suggested retail price for comparable relational full-screen report writer.

dBMAN Highlights:

- dBASE II and dBASE III+ compatibility
- 320 extended commands and functions
- Password protection and data security at field level
- BCD numbers
- Single command menus: vertical, horizontal, scrollable and pull down menu
- Program debugger/editor

Report Writer Highlights:

- User defined pop-up windows and more...
- 9 group levels
- Conditional printing of any items
- Compute running sums, counts, averages, minimums and maximums
- Relate and report from up to 9 database files with lookup (one to one) and scan (one to many) relations and more...

Multi-User Version:

- Locks records and files as a set to prevent deadlock
- Supports transaction update and roll back (Novell TTS system) and more.
- Available for Novell Network, IBM PCNet, Xenix, UNIX and other major operating systems.

Call today to order your copy of dBMAN V !

Versasoft Corporation

4340 Almaden Expwy, Suite 250
San Jose, CA 95118
Phone: 408-723-9044
Telex: 650-263-5806
Fax: 408-723-9046



dBASE III+ and IV are trademarks of Ashton-Tate. FoxBASE is a trademark of Fox Software. Clipper is a trademark of Nantucket. QuickSilver is a trademark of WordTech Systems. Novell Network, IBM PCNet, Xenix, UNIX are trademarks of Novell, IBM, Microsoft, AT&T Bell Laboratories respectively.

WHAT'S NEW

SOFTWARE • CONNECTIVITY

Put Your Mac in the Driver's Seat

MacChuck 1.5 lets you control an IBM PC or compatible from a window on the Macintosh. You can also use the program as a file transfer utility between the two formats. A network communication feature, added to version 1.5, enables you to operate a PC equipped with an Apple LocalTalk card, to be run by any Macintosh in a network.

Other enhancements in version 1.5 include improved file transfer capabilities and enhanced support for the Mac II.

The program comes with the software and cables needed to connect a Mac Plus, SE, or II to a 9- or 25-pin IBM PC serial connector. An adapter is also available for older Mac systems.

Price: \$99.95.

Contact: Vano Associates, Inc., P.O. Box 12730, New Brighton, MN 55112, (612) 788-9547.

Inquiry 1128.

Two with Remote Access

If you need to access your computer from remote locations, there is a variety of remote-control programs on the market. Two previously released programs have had remote capabilities added to them.

Triton Technologies' Session/XL is a remote-control package for use with CO/Session communications software. Session/XL goes a step further by including a scripting and tasking communications language. Using the language, you can set up automatic custom communications sessions. For instance, a host PC can use Session/XL to automati-

cally poll remote PCs for daily sales activity, transfer the data to the host, and then download new information.

You can also use the package to automatically patch software, as well as upgrade and install new versions of applications. Session/XL uses 16-bit CRC (cyclic redundancy check) error checking and automatic compression for file transfers. You can also use the package to manually take control of remote systems.

The program also has error- and screen-checking capabilities. When Session/XL encounters an error, it's automatically recorded and the program continues with the next activity. Screen checking also lets you check a specific line or range of lines for a character string.

Session/XL runs on your host system. Each of the remote PCs must have CO/Session. Both programs run on the IBM PC, XT, AT, PS/2s, and compatibles with DOS 2.0 or higher.

Price: Session/XL, \$225; CO/Session application license, \$125; CO/Session support license, \$175.

Contact: Triton Technologies, Inc., 200 Middlesex Essex Turnpike, Iselin, NJ 08830, (201) 855-9440.
Inquiry 1130.

The asynchronous communications program BitCom has been upgraded with remote-access features, a scroll buffer feature, and automatic data compression with error correction.

The remote-access feature lets you run a program on the host from a remote PC. The scroll buffer review lets you review up to 500 lines of text that have already scrolled by on the screen. And the data-compression feature speeds up file transfers by 2 to 32 times, according to Bit Software.

continued



QNX[®] vs. UNIX OS/2

Architecture can make or break a computer system.

Don't make your systems bear the brunt of massive, monolithic monsters like Unix or OS/2. Instead, build your systems with QNX. The lean, efficient OS that's flexible enough to support any application.

MULTIUSER, MULTITASKING, NETWORKING, AND MORE... QNX is both multiuser and multitasking. OS/2 isn't multiuser. Unix may be multiuser and multitasking, but it will hog a huge chunk of your hard disk and system memory. And neither Unix nor OS/2 can do integrated networking.

QNX, on the other hand, hums along using an efficient 150K of RAM, yet provides a powerful multiuser, multitasking, and integrated networking environment.

TRUE DISTRIBUTED PROCESSING. A QNX-based PC LAN lets any user share any resource on the network—programs, data, devices, even CPUs—without going through the bottleneck of a central file server. With QNX you get mainframe power at micro prices.

ADDED VALUE FOR VARS. QNX is flexible enough to run on any mix of

PCs, ATs, PS/2s, with or without dumb terminals. Even diskless workstations are supported. So whether you start small or grow to mainframe proportions, you can easily build and maintain powerful, fault-tolerant systems without spending a fortune on hardware.

REALTIME PERFORMANCE. Only QNX combines the performance of a dedicated realtime executive with the convenience of a rich development environment that includes a host of utilities, C compiler, full-screen editor, symbolic debugger, and multiple full-screen windows.

DOS SUPPORT. For those who need their daily dose of DOS, QNX allows a DOS application to run as a single task on each PC on the network.

FREE TECHNICAL SUPPORT. While users of other operating systems have to cough up hefty fees for support, QNX developers enjoy free hotline support and free BBS access. You'll get prompt answers to your questions and you'll share ideas and insights with fellow developers in the QNX community.

It's time to make the move to QNX.

THE ONLY MULTIUSER, MULTITASKING, NETWORKING, REALTIME OPERATING SYSTEM FOR THE IBM PC, AT, PS/2, AND COMPATIBLES

Multiuser	10 (32) serial terminals per PC (AT)
Multitasking	64 (150) tasks per PC (AT)
Networking	2.5 Megabit token passing. 255 PC's and/or AT's per network. Thousands of users per network.
Realtime	4,250 task switches/sec (AT).
Message Passing	Fast intertask communication across the network.
C Compiler	Standard Kernighan and Ritchie.
Flexibility	Single PC, networked PC's, single PC with terminals, networked PC's with terminals. No central servers. Full sharing of disks, devices and CPU's.
PC-DOS	PC-DOS runs as a QNX task.
Cost	From US \$450. Runtime pricing available.

For further information or a free demonstration diskette, please telephone (613) 591-0931.

Quantum Software Systems Ltd. • Kanata South Business Park • 175 Terrence Matthews Crescent • Kanata, Ontario, Canada • K2M 1W8

QNX is a registered trademark of Quantum Software Systems Ltd. The UNIX Operating System is a registered trademark of AT&T. IBM, PC, AT, XT and PS/2, PC-DOS and OS/2 are trademarks of International Business Machines.

Special Introductory Offer

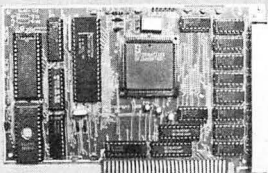

PCSS-8I INTELLIGENT SERIAL BOARD

\$695⁰⁰

- Our most powerful serial card to date.
- 8 Co-processor driven channels per card.
- Dynamically Allocated Buffers.
- BIOS Enhancement Software included, supporting up to 130 channels per computer.
- Baud rates to 57.6k on a half size card.

MODEL 9000 (E)EPROM PROGRAMMER



- Fastest programmer on the market.
- Quick & Intelligent programming algorithms.
- Programs all chips, to one megabit, including single chip processors.
- Programs largest variety of chips including Prom replacements, Eeproms and EEPROMs.

GTEK[®]

DEVELOPMENT HARDWARE & SOFTWARE
P.O. Box 2310; Bay St. Louis, MS 39521-2310 U.S.A.

ORDER TOLL FREE 1-800-255-GTEK (4835) FAX: 1-601-467-0935
MS & Technical Support 1-601-467-8048

IF YOU DESIGN ADD-IN BOARDS FOR THE NEW
IBM PS/2 SYSTEM YOU NEED OUR

MICROCHANNEL 4860 C INTERFACE CHIP

Just some of the Functions implemented:
Program. Option Select * 32 Bit Data Bus Contr.
Multi Device Arbitration * Channel Check Indicator
Memory and I/O Transfer contr. * Wait State Log.
16 Programmable Address Levels.
It comes in a 68 pin PLCC and is fabricated in 1.5u
CMOS, only consumes 150mW. You can replace 10
to 20 TTL devices, a board real estate saving of
20 to 65 sqcm. A reduction of board development
time of some weeks is realistic. Only requires 2
additional 74LS245 for 16 bit systems, or 4 for
32 bit systems. The chip costs US\$ 15,- in
quantities of 5000 and is available now.

**EDC GmbH. Taurusstr.51
8 MUNICH 40 W. GERMANY**

**Tel. (89) 3507076
Fax. (89) 3596180
Tx. 5212599**

IBM, PS/2 and Micro-
channel are registered
trademarks of IBM

Dealer inquiries invited

SOFTWARE • CONNECTIVITY

To run BitCom Deluxe, you need an IBM PC or compatible with 640K bytes of RAM and DOS 3.0 or higher.

Price: \$79.

Contact: Bit Software, Inc., 830 Hillview Court, Suite 160, Milpitas, CA 95035, (408) 263-2197.

Inquiry 1131.

LAN Utility for Windows Users

In an attempt to simplify the use of Microsoft Windows applications running in a network, Automated Design created Windows Workstation, a set of utilities that supports Novell's NetWare.

The program consists of the Windows Menu (which includes Secure Station, Screen Saver, and Windows Intercom) and the printing utility, Windows Print.

Windows Menu is an application organizer designed specifically for networks, according to Automated Design. It uses between 10K bytes and 12K bytes of system memory and allows the LAN system supervisor to build custom menus with password protection and help messages.

Secure Station lets you lock your workstation while Windows applications function in the background. The utility monitors security violations and reports them to the user and the LAN system supervisor.

Screen Saver kicks in automatically if you leave your workstation for a specified period of time.

Windows Intercom sends network messages to and from Windows users. You can also reply to messages without leaving your current application. It also supports messaging between users of different NetWare file servers.

Future versions of this utility package will support other major LAN operating systems, the company reports.

Price: Windows Menu, \$695; Windows Print, \$695; bundled together for \$1195.

Contact: Automated Design, 133 Johnson Ferry Rd., Suite 112, Marietta, GA 30068, (404) 988-0969.

Inquiry 1129.

A Software Meter Reader for Your LAN

Connect Computer calls Turnstyle the electronic equivalent of a software library, enabling multiple users to share a controlled number of copies of a software program on a local-area network.

To use Turnstyle, you load it on your network and enter data about each copy of the software that resides on the network; Turnstyle controls the number of copies in circulation.

The program includes a monitoring system that tells you which users are on the system and what software they are using. You view or print reports of listings about the programs and their use. You can also use Turnstyle to keep track of the serial numbers of your software, although it's not necessary to enter the numbers into the database.

Turnstyle requires an IBM PC or compatible running Novell, Banyan, 3Com, or IBM network operating systems. You also need at least 300K bytes of RAM on the network file server. The workstations need DOS 3.0 or higher, a network interface card, and at least 7K bytes of RAM.

Price: \$195.

Contact: Connect Computer Co., 9855 West 78th St., Suite 270, Eden Prairie, MN 55344, (612) 944-0181.

Inquiry 1132.

continued

1024X768 IBM COMPATIBLE VGA VIDEO CARD

VGAWONDER™

T H E S E C O N D W O N D E R

1024X768

Plus: VGA, EGA, CGA, MDA & Hercules
on Standard MULTISYNC monitors

Yes! the Phenomenal VGAWONDER does it all at IBM Hardware level compatibility with automatic monitor detect and no dip switches or jumpers to set. A HOT CARD for the 286/386 POWER USER with AUTO BUS DETECT for 8 or 16 bit slots, running with a 16 bit datapath with 1:1 interleave. 100% IBM HARDWARE LEVEL COMPATIBILITY means that ALL software and operating systems designed for IBM systems will run. 1024 WILL BE DISPLAYED IN COLOR ON STANDARD MULTI-FREQUENCY MONITORS. Although these features are expected from ATI they are NOT AVAILABLE from other manufacturers. EGA on all monitors including RGB & TTL means a perfect card for networks. MOUSE ON BOARD! ATI built the mouse right in to this one, why not? No extra charge! VGAWONDER is available in both 512K and 256K Versions. Ask your dealer for more information.



TECHNOLOGIES INC.

Technology you can Trust.

ATI Technologies Inc.
3761 Victoria Park Ave., Scarborough, Ontario
Canada M1W 3S2 Telex: 06-966640 (ATI TOR)
Tel: (416) 756-0718 Fax: (416) 756-0720



Circle 23 on Reader Service Card

ATI, VGA WONDER — ATI Technologies Inc.; Multisync — NEC Home Electronics Inc.;
AUTOCAD — Autodesk Inc.; WINDOWS — Microsoft Inc.; GEM — Digital Research Inc.;
VENTURA — Xerox Corp.; HERCULES — Hercules Computer Technology Inc.;
IBM, VGA, EGA, CGA — International Business Machines Corp.

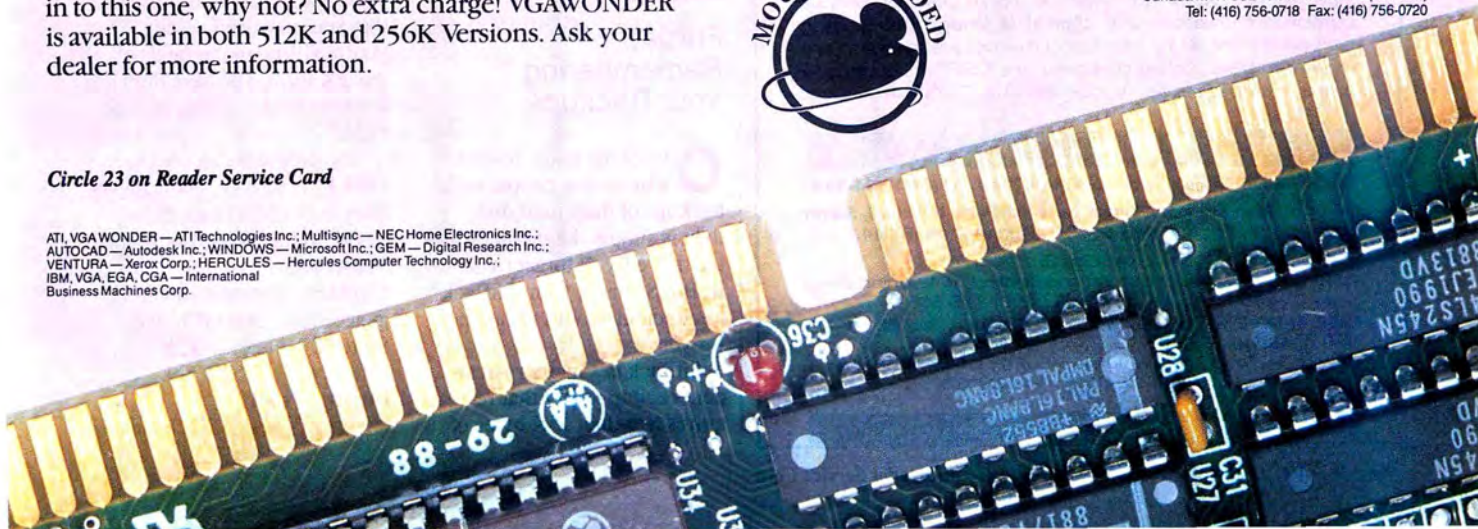

12 MFLOPS — OR — 40MIPS

VECTOR/SIGNAL PROCESSOR

VECTOR 32

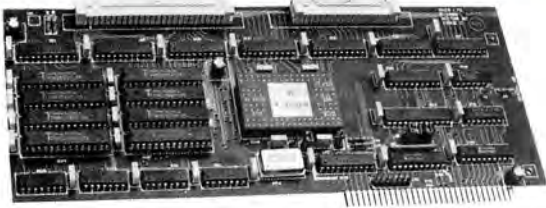

- AT&T DSP Floating Point Processor running at 24MHz
- Plug-in card for IBM™ PC, AT, XT or PS2/30
- 1024 point complex floating point FFT in 8.9ms
- Expansion facilities including IMByte memory & 100 KHz/330 KHz 12 bit data acquisition
- 'C' & Fortran vector processing libraries
- Full development environment

PARALLEL PROCESSOR/REAL-TIME CONTROLLER

PP2000

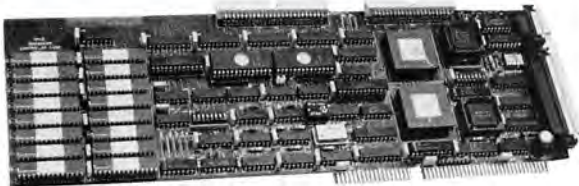

- Harris RTX 2000 Real-time RISC processor
- Plug-in card for IBM™ AT
- 100ns cycle time
- Combines multiple FORTH instructions into a single cycle
- 'C' compiler
- Executes FORTH as its assembler
- Upto 512 kBytes 0 or 1 waitstate static RAM
- Expansion connector for high performance data acquisition
- 16 TTL outputs & 8 TTL inputs capable of 10 MBytes/sec.

The Vector 32 & the PP2000 form part of SMIS's comprehensive control, digital & image processing range. Data capture cards and memory expansion are available. Soon to be released are DSP32C boards & a graphics processor based on the TMS 34010 chip.

FOR FURTHER INFORMATION CONTACT:

SMIS, 130 Elm Street, Cambridge MA 02139. Tel (617) 354-7541
SMIS Ltd, Alan Turing Rd, Surrey Research Park, Guildford, Surrey GU2 5YF. UK. Tel: (44) 483 506611. Fax: (44) 48363114.

AGENTS:

Communications Automation and Control, 1642 Union Blvd - Suite 0, Allentown, PA 18103. Tel (215) 776 6669
Diantek, P.O. Box 141, 6 8500, Torsby, Sweden. Tel: 0560-119-90. Fax: 0560-136-65.

Electronic Tools, Am Waldfriedhof 7, D4030 Rottingen 1, W. Germany. Tel: (02102) 841013. Fax: (02102) 841000.

Fastback Plus with New Features

Fastback Plus 2.0 offers improved restore and backup functions and an improved user interface.

The restore function now has a feature that estimates the number of files, amount of volume, and time needed to complete the restore, as well as the names for the backup sets that should be used. During restore, version 2.0 warns you if there isn't enough space on the target drive.

Another new feature, Smart Restore, prompts you for the exact backup disks needed and warns you if you insert the wrong one.

Other improvements include the option of appending incremental backups to an existing backup set. The program now warns you if you're using disks with data on them. A verify function lets you compare backup files with those on the hard disk.

Fastback Plus 2.0 runs on the IBM PC, XT, AT, PS/2s, and compatibles with at least 320K bytes of RAM and DOS 2.1 or higher.

Price: \$189.

Contact: Fifth Generation Systems, Inc., 11200 Industrialplex Blvd., Baton Rouge, LA 70809, (504) 291-7221.

Inquiry 1136.

Forget Remembering Your Backups

One of the many reasons why so few people make backups of their hard disk data is simply the memory factor: It's easy to forget to do it. But SitBack, from SitBack Technologies, will remember for you.

SitBack is a memory-resident backup utility that requires less than 15K bytes of

memory. Once you load it and tell it which files to back up, it constantly monitors your hard disk for new or changed files. Then, when you don't use the keyboard for a specified length of time, it goes to work automatically, backing up the files to any DOS device you define, such as a floppy disk drive, a removable hard disk drive, a cartridge, a second hard disk drive, or a network device.

The program works with any MS-DOS-based system and is compatible with IBM NetBIOS networks.

Price: \$99.

Contact: SitBack Technologies, Inc., 7219 West 95th St., Suite 301, Overland Park, KS 66212, (913) 894-0808.

Inquiry 1137.

Copyright It

To simplify the process of obtaining copyrights for your software creations, Synthetic Intelligence has developed Copyright-It. The program opens with a license agreement, and Form TX from the U.S. Copyright Office is available in the main menu.

Copyright-It runs you through the advantages and disadvantages of copyrighting, takes you step by step through the registration process, and offers other forms that you may need. When you're filling in the fields of the TX form, you have three levels of help available in each field.

The program runs on the IBM PC, XT, AT, and compatibles with 256K bytes of RAM and DOS 2.11 or higher.

Price: \$25.

Contact: Synthetic Intelligence, Inc., 286 Fifth Ave., Suite 707, New York, NY 10001, (212) 967-2399.

Inquiry 1138.

continued



Win the Ultimate *Heartbeat*

It's easy. Just enter the CADAM Corvette® Convertible Sweepstakes by June 30, 1989, and picture yourself in the *Ultimate Heartbeat*, from Chevrolet®. See your CADAM dealer today for rules and entry forms. No purchase necessary.*

It's just as easy to get your CAD/CAM/CAE program moving quickly with CADAM®'s software family. Software General Motors relies on to design world-class cars like their new Corvette. Software built around the famous CADAM user interface, which shares a common data format. Software relied on daily by more than 100,000 design

professionals around the world. That's because CADAM for IBM® mainframe computers, PRO CADAM™ for Unix® workstations and new MICRO CADAM Plus™ for high performance PC's are the most powerful integrated CAD/CAM/CAE systems ever.

Everyone wins with CADAM. The Ultimate CAD/CAM/CAE Production Tool. Call toll-free for the name of your nearest dealer. You could *Win the Ultimate Heartbeat*.

*No purchase necessary. Winner will be selected in a random drawing. Sweepstakes valid only within continental U.S.A. and Canada. Open to licensed drivers only. Void where prohibited by law. Entries must be postmarked by June 30, 1989 and received by July 14, 1989 to be eligible. Certain other restrictions apply; see complete rules printed on official entry forms, available only from authorized CADAM dealers.

CADAM . . .
The Ultimate CAD/CAM/CAE Production Tool



CADAM INC

A LOCKHEED COMPANY

Call toll free 1-800-255-5710

CADAM is a registered trademark of CADAM INC. Chevrolet and Corvette are registered trademarks of Chevrolet Division of General Motors Corporation. IBM is a registered trademark of International Business Machines Corp. MICRO CADAM and PRO CADAM are trademarks of CADAM INC. Unix is a registered trademark of AT&T. ©1989 CADAM INC

Desktop Publishing with an Apple II

Personal Newsletter, a desktop publishing program for the Apple II, has been upgraded. Version 2.0 includes a headline editor that produces 18- to 72-point headlines, double-strike and double-density printing, and a laser printer driver.

The program lets you lay out pages, create graphics, and integrate text. You can import text from most word processors, the company reports. Clip art, nine text fonts, and sample newsletters are included.

The program runs on the Apple IIe, IIc, and IIGS. **Price:** \$59.95.

Contact: Softsync, Inc., 162

Madison Ave., New York, NY 10016, (212) 685-2080. **Inquiry 1139.**

Direct from SomeWare

A full-featured statistical package called EcStatic comes from a company named SomeWare in Vermont. The package has a transformation utility that lets you create new variables using programming statements along with a screen-oriented data editor.

The program also has utilities for managing data sets, including a merge utility that enables you to combine two data sets even if they share only some of the variables or cases.

EcStatic runs on any IBM PC, XT, AT, PS/2, or compatible with DOS 2.0 or higher, 512K bytes of RAM, and a floppy disk drive.

Price: \$49.95.

Contact: SomeWare in Vermont, Inc., P.O. Box 215, Montpelier, VT 05602, (800) 451-4580; in Vermont, (802) 496-3173.

Inquiry 1118.

BrainMaker: A Neural Net Simulator

With this neural network simulation program, you can design, build, train, test, and run neural nets. The program lets you decide how you want your neural net assembled and trained, and it does the rest.

According to California Scientific Software, BrainMaker runs at up to 500,000 neural connections per second and supports five types of linear and nonlinear neurons. The program offers I/O facilities for visual or symbolic data manipulations.

Sample neural nets are included on optical character recognition, speech synthesis, image recognition, and image enhancement.

To run the program, you'll need an IBM PC, XT, AT, PS/2, or compatible, 256K bytes of RAM, DOS 3.0 or higher, and a monochrome or color display.

Price: \$99.95.

Contact: California Scientific Software, 160 East Montecito, Suite E, Sierra Madre, CA 90124, (818) 355-1094. **Inquiry 1120.**



CarrierNet Makes Peripheral Sharing And Office Networking Fast, Affordable, And "Cableless"

Today's office environment requires a flexible solution for the costly problem of equipment and effort duplication.

Carrier Current Technologies, Inc. has the solution, with a line of *cableless* products—The Carrier Office Network. Our expandable, *cableless* network can be used for peripheral sharing, file transfers, network updates, modem sharing and electronic mail service.

The Carrier Office Network features CarrierNET, a *cableless* data transfer system. CarrierNET connects quickly to the serial port of your PC and plugs into the existing electrical wall outlets of your building, turning your office's electrical system into a data transfer network. It does all this without costly, unsightly cables. And, The Carrier

Office Network can be installed, expanded or moved in minutes.

Give us a call. And find out just how economical and efficient a Carrier Office *Cableless* Network can be.

CARRIERNET

by Carrier Current Technologies, Inc.
4905 Pine Cone Drive
Durham, North Carolina 27707
919/490-4970

Dealer Inquiries Welcome.

YOUR NEW YEAR'S COMPUTER HEADQUARTERS

YES-386 20MHZ

- 20 MHz Micronics Motherboard
- 1 MB RAM Expandable to 2MB/More
- 200 Watt Power Supply
- 1.2 MB Floppy Drive (Japan Made)
- 101 Enhanced Keyboard
- Hi-Res Monographics/Printer Card
- 12" Mono Amber Monitor (720x348)

\$1988

25 MHz COMPLETE...CALL

YES-286 12 MHz

- 12/10/6 MHz Motherboard
- 512K RAM Expandable to 1 MB
- 200 W Power Supply
- Hard/Floppy Controller
- 1.2 MB Floppy Drive (Japan Made)
- 101 Key Enhanced Keyboard
- Hi-Res Monographics/Printer Card
- 12" Mono Amber Monitor (720x348)

COMPLETE SYSTEM

\$888

10 MHz COMPLETE...CALL

TURBO 10MHz

- 10/4.77 MHz Turbo Motherboard
- 256K RAM Expandable to 640K
- 150 Watt Power Supply
- 360K Floppy Controller
- 360K Floppy Drive (Japan Made)
- 84 Key Keyboard
- Hi-Res Monographics/Printer Card
- 12" Mono Amber Monitor (720x348)

COMPLETE SYSTEM

\$448

8/4.77 MHz SYSTEM...\$428

HARD DISKS

Seagate 20 MB & WD-GEN	\$249
Seagate 30 MB & WD-27X	279
Seagate 40 MB, ST 251	349
Seagate 40 MB ST 251-1	399
Seagate—All models	Best Price
Micropolis—All models available	Best Price
Micropolis 72 MB	549

DISK DRIVES

TEAC 360KB/1.2 MB	\$65/85
FUJITSU 360KB/1.2 MB	60/80
3 1/2" 720KB/1.44 MB	80/90
APPLE COMP. Disk Drive	11e \$90/11c \$99

MONITORS

14" Monitor (720x348)	\$88
14" Flat Screen Amber/Green	125
15" Dualscan Monitor	128
EGA Monitor (640x350)	325
Samsung Multisync	475
NEC Multisync Plus, II, XL	CALL
Tape Back-Up	LOWEST
VGA Board & Multisync Monitor	650

ADD ON BOARDS

Monographics Card w/Printer Port	\$45
Color Graphic Card w/Printer Port	40/45
EGA Cards	CALL
286-10 mhz Motherboard O/K	225
286-12 mhz Motherboard O/K	275

Turbo 10 mhz 8088 O/K	75
Video-7-EGA/VGA	175/249
Orchid Designers	325
720/360K Floppy Controller Card	18
Multi I/O Card	48
Printer Card	20
RS-232	20
Clock Card	25
Game Card	20
1.44/1.2M/720K/360K Floppy Master	48
1.2 MB Floppy Controller	48
286 I/O Card	39
2nd Serial Kit (8088/80286)	15/25
286 W.D. Floppy/Hard Controller	99
2MB EMS RAM Card (8088/286)	75/85
Internal Modem (1200/2400)	49/99

SERVICE

- 8088/286 & ALL MODELS
- Hardware Installation & Troubleshooting
- Software SetUp & Training
- Available For Emergencies With Appointment
- Reasonable rates

MISC.

Gender changer	\$6
Printer cable 6'/9'/15'	6/9/15
6' RS-232 cable (M-F, M-M, F-F)	8
Monitor Extension Cable	8
Keyboard Extension Cable	8
Hard/Floppy Disk Cable	8
8088 Case	27
8088 Case 286 Lookalike	35
286 Case	45
286 Slide-In Case	54
Diskette Box (cap 100 pcs)	6
Data Switch Box (AB:ABC:ABCD)	20/24/29
Dot Matrix Printer	CALL
Power station (with surge)	29
Surge Protector (UL Approved)	10
101 Enhanced Keyboard	39
LogiTech OEM Mouse	50
Mouse Pad	5
Printer Stand (80/132 Columns)	14/19
System Stand	14
Joystick	20

**We Carry Too Many Items To List Fully
Call For Products Not Listed**

Y.E.S. MULTINATIONAL INC

Major Corporate P.O.'s and University P.O.'s Welcome.

Dealer Inquiries Welcome • **(415) 657-4888**

44833 FREMONT BLVD., Fremont, CA 94538 Mon-Sat 10-7 FAX (415) 656-0118

TERMS: We accept cash, cashiers checks, personal checks (15 days to clear) and approved purchase orders. California residents add applicable tax. Shipping & handling via UPS Ground \$0.50/lb., UPS BLUE \$1.50/lb., minimum charge \$5. Prices and policies subject to change without notice and we reserve the right to substitute equivalent items. We are not responsible for any typographical errors.

WHAT'S NEW

M I D W E S T

The South Eastern Michigan Computer Organization

The South Eastern Michigan Computer Organization, which first started meeting in 1976, has its roots in an early computer club at Wayne State University and attendees of a seminar by MITS, which produced the Altair computer.

The group now has about 300 members, 100 of whom usually attend the general meeting, which is held the second Sunday of every month at 1 p.m. at Oakland University in Rochester, Michigan. The group is composed mostly of IBM and Macintosh users. Special-interest groups include Macintosh, Commodore 64,

IBM beginners, Lotus 1-2-3 and business users, system languages, and Timex/Sinclair.

The group publishes a monthly newsletter, *Data Bus*, and provides access to bulletin board systems. Annual dues for SEMCO are \$15.

Contact: South Eastern Michigan Computer Organization, P.O. Box 02426, Detroit, MI 48202, (313) 284-2816.

Inquiry 1092.

The Development Center Institute

The Development Center Institute is a nonprofit corporation founded to provide information and education to software project manag-

ers, systems analysts, programmers, and others who need to improve system quality and productivity.

Based in Indianapolis, the group sponsors conferences with sessions on productivity in the Unix environment, system development and enhancement using intelligent workstations, evaluating software productivity, prototyping, and product comparisons of application generators and reverse and reengineering products.

The group is sponsoring a conference at the Peabody Hotel in Orlando, Florida, from February 12 through 15. **Price:** Registration for the conference costs \$645 for members, \$695 for non-members.

Contact: Development Center Institute, Inc., P.O. Box

44087, Indianapolis, IN 46244, (317) 846-2753.

Inquiry 1093.

The Third Annual Users Group Summit Meeting

The Association of PC User Groups' third annual users group summit meeting proved that coordinating an association of about 80 users groups, representing about 100,000 computerists, can be like a meeting of the United Nations General Assembly: a collection of representatives with diverse opinions on just about every topic on the meeting's agenda. And no matter how small the group, it wanted to be heard.

continued



ASSOCIATES

SICK & TIRED OF DBASE®?

You have to generate that new data file program, but you haven't used dBase® since the spring. And the man says "You know dBase®! Make me up the program, pronto!" So you make a stab at it and find that you're looking up the specific format of every second command. What a waste of time!

Is there a better way?

Shouldn't there be a software product that is as automated as we have been expecting—where you just "tell the computer what you want and it does it"?

Now there really is such a simply powerful tool!

Pro-C!

Pro-C builds application programs. You do not have to study and memorize somebody else's convoluted logic that he calls a "programming language."

Need an inventory control program to sell to an important customer? Pro-C can let you put a fully functional package together—with window and context-sensitive help, all the bells and whistles—inside of an hour! That gives you some time to think about how it should look before you have to wade into the project. How many days would it take you to do the same thing with your present methods?

You really do not have to be tied to using "C" or dBase® every week for fear of losing all the time invested in learning that command structure. Let the computer do for you what you help it do for others. Let it do the boring and repetitive stuff! "Well, if it's so easy it can't be good." Did you, such a strong proponent of computerization, really say that?

Pro-C is the next logical step.

Pro-C frees up the time of the programmer, who has been freeing up his client's time with good packages.

And even if you're not a hot shot programmer—even if you just want to make up a few database programs for the church, or the lady down the hall in accounting—you can make those simple programs look so good in a short time that they could sell in a store!

In fact, there are going to be so many useful and saleable programs made by Pro-C people that a separate marketing company is being set up to take the pretty good ones and sell them to the public at large, with the proceeds being split, of course. So you can have fun and make money, too (just like they promised in this industry, long ago).

The list price for Pro-C is US\$485, CDN\$595. This is an investment that you can make back in a week.

Think of what you can do with a money-making package like this! Now stop thinking and start doing!

call OS Associates

Scott Butler

(313) 965-6327 in Detroit, or (519) 977-8068 in Windsor

Com-Tek Data Systems, Inc.

Special Offer—while supplies last—A Bahamas Cruise 5 days and 4 nights with every 286 or 386 purchase. \$675.00 value. Call for details.

SPECIAL COMPLETE SYSTEM

MODEL IQ-8088—I SYSTEM

10 mhz Mother Board—640K Ram
(1) 360K Floppy Drive
Mono Monitor—84 Keyboard
Multi-I/O—Phoenix Bios
Parallel, Serial, Game Ports
Printer Panasonic 1090i
MS-DOS ver. 3.3
20 MB Hard Disk

\$1295⁰⁰

\$895⁰⁰

Model IQ 8088-S

We also carry a complete line of major brand computer peripherals.

Custom configurations are our specialty. On site servicing available.

286-S

Configured to your specifications at a very reasonable price, our A/T is built to suit your every need.

YOUR PRICE

\$1695.00

With CGA **\$1970.00**

EGA **\$2170.00**

VGA **\$2370.00**

MODEL IQ 80286-T

Tower System **\$1795**

Available in 3 case styles



STANDARD A/T MODEL IQ-80286-S

SPECIFICATIONS

MOTHERBOARD: 80286 microprocessor key selectable normal now available with Suntacs 80286 motherboard 6/12 MHz (8.0 mhz) and turbo (12.5 mhz) processing speeds, socketed for the 80287 math coprocessor, eight expansion slots (2 eight bit—6 sixteen bit), clock-cal, 1 meg. RAM included. Expands to 4 meg. Multi I/O and Award Bios included.

POWER: 200 watt, switching power supply with leads for 4 devices.

DISKS: (1) 1.2 meg, half height, dual sided—quad density floppy drive. (1) 40 megabyte, half height, fixed disk drive. 40MS access time.

CABINET: Full size AT style drawer cabinet with corporate security lock panel mounted reset switch, and status LEDs for turbo, power and fixed disk.

KEYBOARD: Enhanced style, 101 keys with LEDs to indicate NUM locks and CAPS lock status, separate cursor pad, numeric touch pad, top mounted function keys.

DISPLAY SET: Hi-res, text and graphics, monochrome card (Herc. compat.) hi-res, TTL amber monochrome monitor. 1 parallel port.

WARRANTY: 1 year on parts and labor limited depot warranty, 30 day money back guarantee if not satisfied with our product, for any reason.

*OPTIONS AVAILABLE

386-S

Powerful performer at a practical price. The ultimate for any business. Just in time for the tax season. Perfect for any accountant or business application.

MODEL IQ 80386-S —THE SUPER WISE CHOICE!

\$3195.00

with EGA monitor **\$3495.00**

CGA **\$3470.00**

EGA **\$3670.00**

VGA **\$3870.00**

Tower System **\$3495.00**

— as shown —

80386-T **\$3395.00**



STANDARD A/T MODEL IQ-80386-S

SPECIFICATIONS

MOTHERBOARD: 80386 microprocessor, user selectable (4.77, 8.0 and 16.0 mhz) upgradeable to 20 mhz. Processing speeds, socketed for the 80287 and 80387 math coprocessor, eight expansion slots (3 eight bit, 4 sixteen bit, and 1 thirty-two bit), clock-cal, 2 meg. RAM included, upgradeable to 16 meg. Includes Phoenix Bios and Multi-I/O card.

POWER: 200 watt, switching power supply with leads for 4 devices.

DISKS: (1) 1.2 meg, half height, dual sided—quad density floppy drive and 1.44 floppy. (1) 80 megabyte, full height, fixed disk drive. Seagate.

CABINET: Full size AT style drawer cabinet with corporate security lock panel mounted reset switch, and status LEDs for turbo power and fixed disk.

KEYBOARD: Enhanced style, 101 keys with LEDs to indicate NUM lock and CAPS lock status, separate cursor pad, numeric touch pad, top mounted function keys.

DISPLAY UNIT: Hi-res, text and graphics, monochrome card (Herc. compat.) hi-res, TTL amber monochrome monitor. 1 parallel port.

WARRANTY: 1 year on parts and labor limited depot warranty, 30 day money back guarantee if not satisfied with our product for any reason.

• COM-TEK HAS DESIGNED THEIR POLICY TO BETTER SERVE, HELP AND PROTECT THEIR CUSTOMERS.

• COM-TEK MAKES SURE ALL THEIR CUSTOMERS GET 1st PRIORITY IN SALES—SERVICE—CUSTOMER RELATIONS

• COM-TEK'S FRIENDLY STAFF IS BETTER TRAINED TO HELP AND SUPPORT YOU IN EVERY WAY POSSIBLE WITHOUT LEAVING YOU ON HOLD.

DEALER INQUIRIES WELCOME

30 DAY MONEY BACK GUARANTEE FOR ANY REASON—1 YEAR ON PARTS AND LABOR—LIMITED DEPOT WARRANTY

SYSTEMS • SYSTEM OPTIONS • NETWORKING CALL FOR SPECIFICATIONS

In N.H.: **603-363-8333**

1-800-942-4255 Outside of N.H.

P.O. Box 221

Corner of 9 & 63, Chesterfield, N.H. 03443

Tech Support Call: 603-363-8334

XT and AT are registered trademarks of International Business Machines.

FREE UPS GROUND SHIPPING
SERVICE IN USA

TAX FREE N.H.

During the meeting, held in Las Vegas during Fall COMDEX 1988, users group officers and representatives debated everything from whether the APCUG's name should be changed to how a worldwide bulletin board system (BBS), announced during the meeting, will be run. But one of the main topics of discussion centered on membership and voting rights.

Several users group members questioned the APCUG's minimum membership requirement for groups to gain APCUG voting rights. According to Jerry Schneider, the executive director of the APCUG, the requirement is necessary to prevent users groups that aren't legitimate from taking advantage of the APCUG. But several people pointed out that of the ap-

proximately 6000 users groups in the country, 4000 have less than 50 registered members. The smaller groups were concerned that although they could join the APCUG and take advantage of its benefits, they could not vote. Others were concerned that if the smaller groups were given the vote, they could gain too much influence.

The APCUG also discussed membership requirements. According to Mr. Schneider, users groups that want to join the APCUG should hold regular meetings and have a hard-copy or electronic newsletter or a BBS.

The first draft of the group's charter proposes a minimum membership of 25. To be a voting member of the APCUG, a group would need at least 100 members. Since

the APCUG is not a users group—it's more similar to a trade association—it's important that users groups that join the APCUG make sure their members receive information in a timely manner. "If groups don't have the mechanism to get information, they won't be providing the service," Mr. Schneider said.

Without a BBS or newsletter, information about the APCUG's activities would likely reach the contact person in the group and stop there. "Groups that [the APCUG] wants to exclude are groups that aren't really serving users," said Jonathan Rotenberg, president of the Boston Computer Society.

The APCUG is an association for users groups that want to improve communication among themselves and major

computer product vendors. Its membership includes international groups and groups from every region of the U.S. **Contact:** The APCUG, 9523 Burdett Rd., Burke, VA 22015, (703) 425-9896. **Inquiry 1087.**

Send Us Your Local News

BYTE is expanding its coverage of local events in the Midwest region. If you would like your event, conference, seminar, or users group covered, please send information to: Regional Editor, BYTE, One Phoenix Mill Lane, Peterborough, NH 03458. Please take into account a three-month lead time for your event.

Important TIPS* for BYTE Subscribers: Receive Product Information 10 Days Earlier!



All you need is a touch-tone telephone and your subscriber I.D. number. See instructions facing the Reader Service Index in the back of this issue for outrageous time-saving opportunities!

*BYTE's Telephone Inquiry Processing Service

Two PCs from Vendex

Vendex Technologies, the company that brought you the original HeadStart Turbo-888-XT, has released two computers: the HeadStart II Plus, which offers 100 percent VGA, IBM PC XT, and PS/2 Model 30 software compatibility; and the HeadStart III, bundled with several software packages.

The HeadStart II Plus runs at 9.54 MHz (switchable to 4.77 MHz) and comes standard with 640K bytes of RAM and a six-in-one VGA graphics adapter. It is powered by an 8088-1 microprocessor and comes with the Friend-Link Telecom System, which features a built-in handset for voice and data transmission and a 2400-bps modem.

The HeadStart III is based on the 80286 microprocessor chip running at 8 or 12 MHz with one wait state and 1 megabyte of standard RAM, expandable to 3 megabytes. The standard system includes a 32-megabyte hard disk drive with a 28-millisecond access time and 1-to-1 interleave. Bundled software includes Ashton-Tate's Framework II, the HeadStart Advanced Environment, 3D Perspective, Executive System's XTree, Splash!, Publish It, and Microsoft's MS-DOS 3.3 and GWBASIC. The system includes three full-length slots and a VGA, EGA, MCGA, CGA, MDA, and Hercules graphics card.

Price: HeadStart II Plus, \$2295; HeadStart III, \$2995.

Contact: Vendex Technologies, Inc., 40 Cutter Mill Rd., Suite 438, Great Neck, NY 11021, (516) 482-4255. **Inquiry 1082.**



The HeadStart II Plus ships with a 40-megabyte hard disk drive.

Norton Utilities' Disk Doctor

The advanced edition of Norton Utilities 4.5, the latest version of the popular data-recovery package, contains a utility that automatically diagnoses and corrects problems with your hard and floppy disks. Available with the advanced edition only, the utility, called the Disk Doctor, lets you repair disks whether you're technically adept or not.

Both the advanced and standard editions of the upgrade include the Norton Control Center, with which you can control system settings, including keyboard rate, video mode, screen and palette colors, serial ports, stop watches, and time and date. You can store the settings in a file and reuse it as a replacement to DOS's Mode command.

Both editions also include a Batch Enhancer for creating interactive batch files with zooming dialog boxes. Other

improvements include Data Protect, which saves information to help Quick Unerase and Unremove Directory recover heavily fragmented files and directories automatically; speed-key searching, rename directory, and EGA/VGA graphics support for 43- and 50-line modes of the Norton Change Directory; ability in the advanced edition's Format Recover to save an accidentally reformatted hard disk; and Safe Format, which you can use to reformat a floppy disk in as little as 3 seconds without permanently losing data previously on the disk.

Norton Utilities 4.5 works with the IBM PC, XT, AT, PS/2s, and compatibles with DOS 2.0 or higher and at least 192K bytes of RAM. **Price:** Standard edition, \$100; advanced edition, \$150. **Contact:** Peter Norton Computing, 100 Wilshire Blvd., Ninth Floor, Santa Monica, CA 90401, (213) 319-2000. **Inquiry 1079.**

Convert AppleWorks Files to PC Formats

Cross-Works, a utility for AppleWorks, the most popular integrated software package for the Apple II, transfers and converts files into DOS-compatible files with all formatting information intact, SoftSpoken reports.

The program lets you convert AppleWorks word processor files into WordPerfect format, while retaining such formats as underlining, bold-face, centering, and margins. Spreadsheets are converted to Lotus 1-2-3 files that have not only the correct data, but also intact spreadsheet formulas and cell formats. Similarly, you can convert AppleWorks database files to dBASE III-compatible files, complete with original field names. You can also use the program to transfer ASCII text files.

The package comes with an 8-foot cable that plugs into the Apple's or the IBM or compatible's serial ports. On one end, the cable has three connectors that fit the Apple IIe, IIc, and IIGS models. On the other end, a 9- or 25-pin connector fits your IBM PC, XT, AT, or compatible's serial port. SoftSpoken reports that if the computers are more than 8 feet from each other, you can transfer files by using a 1200-bps modem.

Cross-Works can transfer and convert on the fly a 30,000-byte AppleWorks spreadsheet file into a Lotus 1-2-3 WK1 file in about 20 seconds, according to the company.

Price: \$79.95. **Contact:** SoftSpoken, P.O. Box 97623, Raleigh, NC 27624, (919) 878-7725. **Inquiry 1074.**

Compare Computers Inc.

Orders, Call Toll Free

Tech Support & Information

Fax Number

1-800-888-2983

1-612-881-9197

1-612-881-9197

Mailing Address: 9801 Dupont Ave. So., Suite 175 Bloomington, MN 55431

ORDER DESK & TECHNICAL SUPPORT OPEN: M-F 9a.m.-5p.m. CST

EVEREX Model 3000A

16MHZ-386

- 64 K Static RAM cache
- 1 MB-100NS Dram
- 1.2 MB Floppy
- Hard drive floppy controller

\$1795.00



EVEREX Model 1700C

12MHZ-286

- 1 MB 100NS Dram
- 1.2 MB Floppy
- Hard drive floppy controller

\$1295.00



National On-site Warranty Service Available on ALL EVEREX Computers

EVEREX Model 1800

8MHZ-286

- 512 K RAM
- 1.2 MB Floppy
- Hard drive floppy controller

\$799.00



LOGITECH 2 Button Serial Mouse

**SPECIAL
\$39.95**



ACCOUNTANT 111 KEYBOARD

Enlarged Enter, Shift, Backspace Key

Adjustable Solar
Powered Calculator

- Tactile/Click Key Switch
- XT, AT and Novell Compatible

Ctrl.
Capslock
Alternative

**SPECIAL BYTE PRICE
CALL!**

On/Off Switchable For
Numeric Pad and Calculator



WE WELCOME EDUCATION AND CORPORATE ACCOUNTS

IF WHAT YOU'RE LOOKING FOR IS NOT LISTED — CALL!

ALDUS	
PAGEMAKER	\$499.00
ASHTON-TATE	
D BASE III +	\$395.00
D BASE IV	\$469.00
FRAMEWORK III	\$439.00
MULTIMATE ADV II	\$279.00
DRAW APPLAUSE	\$259.00
RAPIDFILE	\$189.00

ATI	
VGA WONDER	\$329.00
VIP	\$269.00
2400 ETC MODEM INT.	\$179.00

CENTRAL POINT	
PC TOOLS DELUXE	\$45.00
COPY II PC	\$21.00
COPY II PC OPTION	\$109.00

DAC	
DAC EASY ACCOUNTING	\$59.00
DAC EASY PAYROLL	\$59.00
DAC EASY LIGHT	\$45.00

DELTA TECH	
DIRECT ACCESS	\$55.00
DIRECT NET	\$149.00
EXTRA	\$59.00

DIGITAL RESEARCH	
GEM DESKTOP	\$29.00
GEM DRAW PLUS	\$169.00
GEM 1ST WORD PLUS	\$109.00
GEM WORD CHART	\$114.00
PRESENTATION TEAM	\$279.00
DESKTOP PUBLISHER	\$169.00

EVEREX	
10MB-1MB CHIPS - 10MB BOARD	\$129.00
3MB-256 CHIPS - 3MB BOARD	\$89.00
8MB-1MB CHIPS LIN 4.0 8MB BOARD	\$245.00
0-576K HALF CARD	\$39.00
286 MHZ TURBO BOARD	\$245.00
EVERGRAPHICS PLUS MONO	\$59.00
MICRO-ENHANCER DELUXE EGA	\$149.00
EV 673 EVGA-VGA ADAPTER	\$259.00
INT 40MB TAPE-FLOPPY CONT	\$319.00
EXT 40MB TAPE	\$599.00
1200B INTERNAL MODEM	\$75.00
2400B INTERNAL MODEM	\$149.00
2400B EXTERNAL MODEM	\$179.00

EXECUTIVE SYS	
HOT V 4.0	\$95.00
XTREE PRO	\$69.00
XTREE	\$39.00

FUNK SOFTWARE	
INWORD	\$59.00
NOTEWORTHY	\$49.00
SIDEWAYS	\$45.00

GENERIC SOFT	
GENERIC CADD 3.0	\$55.00
PEN PLOT	\$27.00
DOT PLOT	\$27.00
AUTO CONVERT 3.0	\$27.00
AUTO DIMENSIONING 3.0	\$27.00
3D SOLIDS V. 2.2	\$179.00

INTEL	
MATH CO-PROCESSORS	
5 MHZ XT	\$99.00
8 MHZ XT	\$149.00
10 MHZ XT	\$199.00
6 MHZ 286	\$159.00
8 MHZ 286	\$229.00

10 MHZ 286	\$269.00
16 MHZ 386	\$409.00
20 MHZ 386	\$479.00
25 MHZ 386	\$589.00
386/SX	\$429.00

INTELLICOM	
LONGLINK	\$129.00
MEGALINK	\$269.00
QUICKLINK P/S 16K	\$99.00
QUICKLINK S/P 16K	\$99.00

LATTICE INC.	
LATTICE C COMPILER V.3.3	\$215.00

LOTUS	
SYMPHONY V.2.0	\$429.00
METRO	\$59.00
HAL	\$99.00
AGENDA	\$249.00
FREELANCE PLUS	\$329.00
1-2-3 V.2.01	\$299.00

MATHSOFT	
MATHCAD V.2.0	\$199.00

MAXTOR	
MFM-120MB 28MS	\$1,395.00
MFM-160MB 28MS	\$1,569.00
ESDI-317MB 16MS	\$2,295.00
ESDI-600MB 16MS	\$4,295.00

MECA	
MANAGING YOUR \$ V.4.0	\$125.00

MERIDIAN TECH	
CARBON COPY PLUS V.5.0	\$115.00
DEJA VIEW	\$59.00

MICROGRAFX	
DESIGNER V.1.2	\$449.00
DRAW PLUS	\$269.00
IN A VISION	\$329.00
WINDOWS DRAW	\$199.00

MICROLYTICS	
GOFER	\$39.00
WORDFINDER	\$39.00

MICROPOLIS	
MFM-44MB 28MS	\$522.00
MFM-71MB 28MS	\$589.00
ESDI-142MB	\$1,295.00
ESDI-338MB	\$2,159.00

MICROSOFT	
WINDOWS 286	\$62.00
WINDOWS 386	\$119.00
WORKS	\$99.00

MIGENT	
ABILITY	\$59.00
POCKET MODEM	\$115.00

NANTUCKET	
CLIPPER	\$435.00

NEC	
P2200 24-PIN	\$359.00
P5200 24-PIN	\$529.00
P5300 24-PIN	\$689.00
MULTISPEED EL/II	\$1,495.00
MULTISPEED HD	\$2,395.00
MULTISYNC II	\$589.00
MULTISYNC GS	\$269.00
MULTISYNC PLUS	\$949.00
MULTISYNC XL	\$2,195.00
MONOGRAPH 16" W/CARD	\$1,499.00

NORTHEGE SOFTWARE	
TIME SLIPS III	\$119.00

OKIDATA	
320 9-PIN	\$359.00
321 9-PIN	\$489.00
390 24-PIN	\$489.00
391 24-PIN	\$679.00
393 24-PIN	\$969.00
INTERNAL 1200 BD MODEM	\$129.00
INTERNAL 2400 BD MODEM	\$189.00
EXTERNAL 2400 BD MODEM	\$229.00

PANASONIC	
1124 24 PIN	\$349.00
1524 24-PIN	\$559.00
1592 9-PIN	\$409.00
1092i 9-PIN	\$329.00

PARADISE SYS	
AUTOSWITCH 480	\$179.00
VGA PLUS	\$279.00
VGA PROFESSIONAL	\$399.00

PAUL MACE SOFT	
MACE UTILITIES V.4.1	\$59.00
GRASP V.3.1	\$79.00

PEACHTREE SOFT	
PEACHTREE COMPLETE II	\$159.00

PETER NORTON	
NORTON COMMANDOR	\$52.00
NORTON EDITOR	\$49.00
NORTON UTILITIES V.4.0	\$57.00
NORTON UTL ADVANCED	\$79.00

PLUS DEVEL	
HARDCARD 20MB	\$529.00
HARDCARD 40MB	\$659.00

PRINCETON GRAPH	
ULTRASYN	\$529.00

ROLAND CORP.	
DPX-2000 DRAFTING PLOTTER	\$1,989.00
DPX-3300 DRAFTING PLOTTER	\$3,450.00
GRX-3000 DRAFTING PLOTTER	\$3,529.00
GRX-400E DRAFTING PLOTTER	\$4,989.00
DXY-885 XY PLOTTER	\$695.00
DXY-98A XY PLOTTER	\$1,229.00
DXY-990 XY PLOTTER	\$1,059.00
PLOTTER CABLE (SPECIAL)	\$25.00

RYAN McFARLAND	
XENIX OR UNIX	\$795.00
IBM PC COBOL	\$595.00
85-386 UNIX	\$1,495.00

SANTA CRUZ	
XENIX SYS COMP V.2.2 286/AT	\$895.00
XENIX SYS COMP V.2.2 386/AT	\$995.00

SEAGATE	
ST-225 20MB 65MS	\$229.00
ST-225 20MB 65MS W/CONT	\$269.00
ST-125 20MB 30MS	\$249.00
ST-138 30MB 30MS	\$299.00
ST-138 30MB 30MS W/CONT	\$365.00
ST-251 40MB 40MS	\$359.00
ST-251-1 40MB 28MS	\$399.00
ST-4096 80MB 28MS	\$599.00

SOFTWARE PUB	
HARVARD GRAPHICS	\$279.00
HARVARD PROJECT MANAGER	\$369.00
PROFESSIONAL WRITE	\$115.00
PROFESSIONAL FILE	\$179.00

STORAGE DIMS	
SPEED CACHE	\$39.00

SPEEDSTOR UTILITY	\$49.00
-------------------	---------

SYMANTEC CORP.	
NOTE-IT PLUS	\$55.00
O & A	\$199.00
READY	\$62.00
SQZ PLUS	\$59.00
TIME LINE V.3.0	\$349.00
4 WORD	\$62.00

TOPS-SUN MICRO	
TOPS FLASHCARD	\$169.00
TOPS FOR DOS	\$119.00
TOPS NETPRINT	\$119.00

TOSHIBA	
PORT PRINT 60 CPS PAR INT	\$349.00
NAR DOT MAT 180/60	\$429.00
24-PIN NAR DOT MAT 216/72	\$449.00
24-PIN NAR DOT MAT COLOR	\$669.00
24-PIN WID DOT MAT 216/72	\$699.00
24-PIN WID DOT MAT 360/120	\$1,095.00
512K MS-DOS 2.11 ROM, 6.4LB	\$799.00
1MB, 384KB EMS, 10LBS	\$1,459.00
WITH BACKLIT LCD	\$1,599.00
1MB, 384KB EMS, 11LBS, 20MB HD\$2,399.00	
WITH BACKLIT LCD	\$2,499.00
1MB, EGA, BL-LCD, 286/12, 20HD, 3.3	\$3,399.00

1MB, VGA, GAS PLAZ, 286/12, HD\$2,895.00	
1MB, 40MB HD, EGA, 286/12	\$3,795.00
1MB, EGA, GASPLAS, 386/16	\$4,795.00
T-5200-40	\$6,195.00
T-5200-100	\$7,259.00

US ROBOTICS	
E2400 COURIER MODEM	\$369.00
HST COURIER 9600 BD	\$669.00

VIDEO 7	
FAST-WRITE-VGA	\$369.00
V-RAM VGA	\$489.00
VEGA	\$179.00
VEGA DELUXE	\$229.00
VEGA VGA	\$289.00

WESTERN DIGTL	
EITHERCARD PLUS/IBM PC	\$219.00
WD1007 A-WAH ESDI HD CONT	\$229.00
WD1007 A-WA2 ESDI HD FLOP CT	\$259.00

WORDPERFECT	
WORDPERFECT V.5.0	\$235.00
DATA PERFECT	\$299.00
PLAIN PERFECT	\$199.00
WORD PERFECT LIBRARY	\$69.00
WORD PERFECT OFFICE	\$259.00

XEROX	
VENTURA 2.0	\$499.00

XOR	
NFL CHALLENGE	\$69.00

Z-SOFT	
PC PAINTBRUSH+V.1.6	\$79.00
PC PAINTBRUSH+DESIGN SERIES	\$149.00
PUBLISHERS PAINTBRUSH V.1.6	\$149.00
PUBLISHERS TYPE FOUNDRY	\$249.00

ZENITH	
SUPERSPORT	\$1,649.00
SUPERSPORT M20	\$2,495.00
SUPERSPORT 286 M20	\$3,299.00
SUPERSPORT 286 M40	\$3,699.00
TURBOSPORT 386 M40	\$5,295.00

Compare Computers Inc

Orders, Call Toll Free

1-800-888-2983

Tech Support & Information

1-612-881-9197

UNDER-WARE ELECTRONICS

**FAST TRAX
HARD DISK
OPTIMIZER
\$49.00**

**UNDER-PRICED HARD-WARE &
UNDER-PRICED SOFT-WARE**

**SAVE UP TO
63% OFF
ON PORTABLES**

IN BUSINESS FOR OVER TWELVE YEARS

SHARP PORTABLE COMPUTERS PC-7100

7.37 MHZ 8086 PROCESSOR, 5 1/4" 360K FLOPPY DISK DRIVE,
TWENTY MEGABYTE HARD DISK, PARALLEL AND SERIAL PORTS,
320K RAM (EXPANDABLE TO 704K),
ELECTRO-LUMINESCENT BACKLIT SCREEN.
INCLUDES DOS 2.11 & GW-BASIC 2.11



PC-7100 SPECIAL PRICE

\$1,099.00

ORIGINAL LIST: \$2,995.00

PC-7202 SPECIAL PRICE

\$1,399.00

ORIGINAL LIST: \$2,995.00

PC-7202

10.8.6 MHZ 80286 PROCESSOR, DUAL 1.2MB FLOPPY DISK DRIVES,
PARALLEL AND SERIAL PORTS, RGB EXTERNAL MONITOR PORT,
640K RAM (EXPANDABLE TO 1.6MB),
ELECTRO-LUMINESCENT BACKLIT SCREEN.
FULL SIZE XT/AT EXPANSION SLOT.
INCLUDES DOS 3.2 & GW-BASIC 3.2

NEC MULTISPEED-EL

4.77/9.54 MHZ, 640K RAM, DUAL 720K DISK DRIVES,
PARALLEL & SERIAL PORTS, RGB MONITOR PORT,
ELECTRO-LUMINESCENT BACKLIT SCREEN
DOS 3.2, POP-UP SOFTWARE.
NI-CAD BATTERY PAK & A C ADAPTER INCLUDED.



NEC
MULTI-SPEED
DELUXE
CARRYING
CASES
SPECIAL PRICE
\$69.00
LIST: \$129.00

CALL
ABOUT
SPECIAL
PRICING
ON
OTHER
NEC
ADD-ONS

YOUR
SPECIAL
PRICE

\$999.00

ORIGINAL LIST: \$2,495.00

ITT XTRA XP XT-286 SYSTEM

80286 PROCESSOR, 4.77/6.0 MHZ, 512K RAM, SERIAL AND
PARALLEL, FLOPPY DRIVE CONTROLLER, KEYBOARD.
ORIGINAL LIST \$1,995.00

PERIPHERAL DRIVE CHOICE	CHOICE	WITHOUT VIDEO	MONO MONITOR & CARD	COLOR MONITOR & CARD
NO DRIVES		\$499.00	\$579.00	\$679.00
360K FLOPPY & 20 MB HD		\$799.00	\$879.00	\$979.00
360K FLOPPY & 30 MB HD		\$899.00	\$979.00	\$1079.00
360K FLOPPY & 40 MB HD		\$1099.00	\$1179.00	\$1279.00

TO CHOOSE THE CONFIGURATION YOU WANT, SIMPLY LINE UP YOUR
CHOICE OF DRIVES WITH YOUR CHOICE OF MONITOR.

FACTORY REFURBISHED MONITORS WITH ONE YEAR WARRANTY

PROCORP SERIAL MOUSE W/ DR HALO III

\$59.00

CANON LASER PRINTER

LBP-8A1

8 PAGE PER MINUTE
CANON CX ENGINE

\$899.00

ORIGINAL LIST \$3,000.00

MONITOR SPECIALS UP TO 82% OFF!!

COLOR	LIST	YOUR PRICE
14" COMPOSITE THOMSON.....	\$595	\$99
14" RGBI CGA THOMSON.....	\$499	\$199
MONOCHROME		
12" GREEN TTL THOMSON.....	\$199	\$69
12" GREEN COMPOSITE SMITH CORONA.....	\$134	\$49

FULL FACTORY WARRANTY
FACTORY REFURBISHED

TALLGRASS

TAPE BACK-UP SYSTEMS

TG1020e 20MB EXTERNAL.....	\$249.00
TG1040i 40MB INTERNAL.....	\$399.00
TG1040e 40MB EXTERNAL.....	\$449.00
TG1425i 20MB IID/ 20MB TBU INTERNAL.....	\$399.00

QUANTITIES LIMITED. ALL MERCHANDISE AVAIL-
ABLE ON A FIRST COME, FIRST SERVE BASIS. ALL
MERCHANDISE GUARANTEED. 15 DAY RETURN PRIVI-
LEGE WITH RMA. RESTOCKING CHARGE ON
RETURNS. NO SURCHARGE FOR MC, VISA, OR DIS-
COVERCARD. COD ORDERS ACCEPTED WITH CASH
OR CASHIERS CHECK.

**UNDER-WARE
ELECTRONICS**
1970 S. WEST ST. #365
WICHITA, KS 67213

800-442-1408

IN KS 316-942-9797
FAX 316-942-9816

SHORT TAKES

BYTE editors' hands-on views of new products

MegaMate

MKS Make, Lex, and Yacc

Wordbench

DataSentry

Language Systems
FORTRAN

Sourcer



The Little Drive That Could

There's no escaping the world of multiple floppy disk formats, especially if you get your disks from different sources or switch back and forth between a laptop computer and an older (pre-PS/2) desktop computer. If you need to work with 3½-inch floppy disks but have only a 5¼-inch floppy disk drive in your main computer, the **MegaMate** 3½-inch external drive is a solution in the true sense of the word. And it's about as easy a solution as you can get, short of buying a new system with a 3½-inch drive built in.

MegaMate, which is a sleek little disk drive designed by someone who realizes the value of desktop real estate, works with any IBM PC, XT, AT, or compatible that can spare a half-size slot. Hooking it up is a snap. After checking the jumper blocks to make sure they're set correctly (the unit I received came properly positioned), you just slip the MegaMate card into the expansion slot, screw it down, and plug the drive into the port. Installing the software, on either a hard disk or a system disk, is equally simple.

MegaMate functions just like a native drive in that you can access it from applications

and use DOS utilities such as COPY, DIR, CHKDSK, and CD. FORMAT, DISKCOPY, and DISKCOMP will work only with DOS 3.3 or higher, but the MegaMate software has its own formatting command that works with DOS 2.0 and higher.

The drive can initialize 3½-inch disks in 720K-byte and 1.44-megabyte formats (the latter being the default). The unit can detect what kind of disk it's looking at, so you have to specify only density when you're initializing a floppy disk. Micro Solutions said it will soon have a utility program that will let you format disks as a background task, but that update wasn't

ready when we went to press.

I've been using MegaMate as my regular floppy disk drive for several weeks now, and I haven't seen any problems in terms of operation or reliability. The external unit has blended right in with the AT clone I use at work, doing none of the things that sometimes happen when you add a piece of hardware. The only weird thing I've seen is found in the boot-up screen message that flashes MegaMate's designation. The message, a two-liner, I think, says that the drive is available as drive D, but the thing whizzes by so quickly, and amidst a whole screen full of text, that I had to call it up 20 times before I

could see the message that said my MegaMate was drive D.

At \$349 for drive, card, and cable, MegaMate is priced comparably with other external drives. (With higher-capacity floppy disk drives coming soon, like Konica's 10-megabyte unit, I wouldn't want to invest much more than that in an extra disk device.)

If you've got to read from or write to 3½-inch disks and can't afford a more modern computer with built-in drives for the smaller floppy disks, the MegaMate is worth the money. Sure beats having to bother a coworker with a 3½-inch floppy disk drive.

—D. Barker

THE FACTS

MegaMate
\$349

Requirements:
IBM PC, XT, AT, or compatible with at least 128K bytes of RAM, DOS 2.0 or higher, and a half-size slot.

Micro Solutions, Inc.
132 West Lincoln Hwy.
De Kalb, IL 60115
(815) 756-3421
Inquiry 1035.

Unix Tools for DOS

Unix tools for MS-DOS users? Who wants them! Wait, there must be something valuable here, or Mortice Kern Systems would have been out of business years ago when it started shipping packages of classic Unix tools that are written and compiled for MS-DOS.

The company now has two new programs. **MKS Make** is

traditionally used for defining the dependencies of program source code files so that appropriate recompilation and linking can take place when one or more modules or libraries have been modified. However, its use is not limited to programming. Many documents have dependencies on other documents. If, for example, parts of accounting

sheets are included in other documents, changes in the accounting requires reformatting the documents. This process is automated through the use of MKS Make. Containing Mortice Kern's RCS (Revision Control System, similar to Unix sccs), MKS Make gives the same sturdy programming and documentation manage-

continued

ment to MS-DOS users that Unix developers have been boasting about for nearly two decades. It can use both Unix and Microsoft control definitions.

MKS Make supports Turbo C, Microsoft C, WATCOM C, and other compilers, libraries, and linkers. It works with the MKS Toolkit Korn Shell, as well as with standard DOS COMMAND.COM.

The second new program is **MKS Lex and Yacc** (for "yet another compiler compiler"). Lex and Yacc are tools used specifically for software development. Lexical analysis is the set of operations that determines the nature of input in an application program. For example, a lexical analyzer determines whether you are inputting text, a value, a function, a macro, or a command when you run a spreadsheet program. Lex is a program to generate lexical analyzers. Most lexical-analyzer generators do not create fast or com-

compact program modules. Instead, they are used just for prototyping or generating stand-alone data translation systems.

Yacc has been used for generating entire application programs as well as compilers. There are many applications for rule-based systems other than compilers. When an applications developer specifies a set of rules and machine states and/or operations, Yacc can take the specifications and generate the source code for a program or module that follows these definitions.

MKS Lex and Yacc supports the following compilers: Turbo C, Microsoft C, WATCOM C, and others. It is not copy-protected, and there are no royalties or run-time fees.

Mortice Kern has developed an entire suite of more than 130 programs (MKS Toolkit, \$199) that perform the same functions as their equivalents in Unix. I have been using this package for years. None of the

MKS programs contain any AT&T code, but they religiously follow the System V.3 parameters and operations.

Other products from the company include MKS SQPS (SoftQuad Publishing System), compatible with AT&T Documenters Work Bench, \$495; drivers for Hewlett-Packard LaserJet printers and PostScript devices, \$200; MKS Vi (\$149), a total implementation of the classic Unix screen editor; and MKS AWK (\$99), which contains all the features of the new version of the report-generation language from the gurus of Bell Labs. The MKS Toolkit includes everything but SQPS, Make, Lex, and Yacc.

So who uses Unix tools in MS-DOS? I suspect that 50 percent are users with Unix experience who need to work in the MS-DOS world, and the other 50 percent are MS-DOS users wanting to learn more about Unix.

—Ben Smith

THE FACTS

MKS Make \$149

Requirements:
DOS 2.0 or higher
and 256K bytes of RAM;
a hard disk drive is
recommended.

MKS Lex and Yacc \$249

Requirements:
DOS 2.0 or higher
and 256K bytes of RAM;
a hard disk drive is
recommended.

Mortice Kern Systems,
Inc.
35 King St. N
Waterloo, Ontario
Canada N2J 2W9
(519) 884-2251
Inquiry 1036.

Wordbench: Tools Designed with Writers in Mind

Writers of prose typically provide an outliner, a spelling checker, and a thesaurus. Addison-Wesley's **Wordbench** program does all that and more. There's a note-taker that behaves like an electronic stack of 3-by-5 index cards; a reference tool that helps you collect and arrange bibliographic citations; a viewer that you can use to refer to your outline, notes, and citations while working on a document; and even a tool called the brainstormer, which helps you get past a writer's block.

The word processor itself is solid but unspectacular. It supports many of the usual text-editing operations, paragraph formats, and modes of emphasis. The size of your document is limited by available RAM, though, and some conveniences—like a single-

key function to delete a line—are missing. If you're already committed to a word processor, it's unlikely you'll want to switch to this one.

But the word processor does its job, and the environment it works within has some unique

features. One particularly handy feature is the interaction between the note-taker and the outliner. The problem with typical outliners is that you can attach text only to outline items; that compels you to create a skeleton to which you

can then add meat.

Wordbench recognizes that sometimes the meat comes first. Thus, you can use the note-taker to capture thoughts that don't yet fit into your outline. The outline and notes

continued



THE FACTS

Wordbench \$189

Requirements:
IBM PC, XT, AT, or
compatible with 256K
bytes of RAM and DOS
2.0 or higher.

Addison-Wesley
Publishing Co., Inc.
Jacob Way
Reading, MA 01867
(617) 944-3700
Inquiry 1037.



Embedded systems designers have already used CrossCode C in over 291 different applications.

How to choose a 68000 C compiler for your ROMable code development

These twelve important CrossCode C features could make the difference between success and failure

It's hard to know ahead of time what features you'll be needing in a 68000 C compiler. But if you're using CrossCode C you won't need to think ahead, because CrossCode C is already equipped with these twelve important features for your ROMable code development:

1. **A 100% ROMable Compiler:** CrossCode C splits its output into five memory sections for easy placement into ROM or RAM at link time.
2. **Integrated C and Assembler:** You can write your code in any combination of C and assembly language.
3. **Readable Assembly Language Output:** The compiler generates assembly language code with your C language source code embedded as comments, so you can see each statement's compiled output.
4. **Optimized Code:** CrossCode C uses minimum required precision when evaluating expressions. It also "folds" constants at compilation time, converts multiplications to shifts when possible, and eliminates superfluous branches.
5. **Custom Optimization:** You can optimize compiler output for your application because you control the sizes of C types, including pointers, floats, and all integral types.

6. **Register Optimization:** Ten registers are reserved for your register variables, and there's an option to automatically declare all stack variables as *register*, so you can instantly optimize programs that were written without registers in mind.

7. **C Library Source:** An extensive C library containing over 47 C functions is provided in source form.

8. **No Limitations:** No matter how large your program is, CrossCode C will compile it. There are no limits on the number of symbols in your program, the size of your input file, or the size of a C function.

9. **68020 Support:** If you're using the 68020, CrossCode C will use its extra instructions and addressing modes.

10. **Floating Point Support:** If you're using the 68881, the compiler performs floating point operations through the coprocessor, and floating point register variables are stored in 68881 registers.

11. **Position Independence:** Both position independent code and data can be generated if needed.

12. **ANSI Standards:** CrossCode C tracks the ANSI C standard, so your code

will always be standard, too.

There's More

CrossCode C comes with an assembler, a linker, and a tool to help you prepare your object code for transmission to PROM programmers and emulators. And there's another special tool that gives you symbolic debugging support by helping you to prepare symbol tables for virtually all types of emulators.

CrossCode C is available under MS-DOS for just \$1595, and it runs on all IBM PCs and compatibles (640K memory and hard disk are required). Also available under UNIX & XENIX.

CALL TODAY for more information:

1-800-448-7733
(ask for extension 2001)

Outside the United States, please dial

PHONE: 1-312-971-8170
FAX: 1-312-971-8513

SOFTWARE DEVELOPMENT SYSTEMS, INC.
DEPARTMENT 21
4248 BELLE AIRE LANE
DOWNERS GROVE, ILLINOIS 60515 USA

CrossCode™ is a trademark of SOFTWARE DEVELOPMENT SYSTEMS, INC. MS-DOS® is a registered trademark of Microsoft. UNIX® is a registered trademark of AT&T. XENIX® is a registered trademark of Microsoft.

evolve separately; as the structure clarifies, you *link* notes to outline headers. When you're ready to write a first draft, you merge the outline and notes together into a document.

The brainstormer provides a set of tools that people who teach writing will find both amusing and useful. Tech-

niques include free writing, nutshelling, and goal setting. Free writing means that you set a timed interval—say, 2 minutes—then write furiously until the clock runs out. The program won't let you back up or edit, and if you pause for longer than a few seconds, it tells you to keep writing. Nut-

shelling encourages you to write a concise summary of your topic, and goal setting helps you define your audience and point of view.

Wordbench isn't the fanciest word processor around, but its creators have thought hard about the process of writing and have built tools that flexi-

bly support that process. It's a very friendly package that may well appeal both to professional writers who are unfamiliar with computers and to educators who are looking for software that can really help their students learn how to write.

—Jon Udell

Put a Positive Lock on Your Data

It's 2:00 a.m.; do you know where your data is? There's currently a great deal of concern about computer security. Just listen to the news. And you don't have to work for the government to be anxious yourself.

Nearly every business has computerized information that shouldn't go beyond its four walls. It's all too easy for someone to walk in, copy some files to a floppy disk, and walk away with a company's secrets.

Data-security packages, both software and hardware, aren't new. But there's a problem: The most effective ones are expensive and inconvenient to use; the inexpensive ones are marginally useful at best. But the aptly named **DataSentry** from Rainbow Technologies has changed all that. It's economical, it's easy to use, and it provides virtually foolproof security.

DataSentry is a variation of those "hardware keys" that are often used as copy-protection devices for custom software or other expensive packages. Indeed, Rainbow Technologies is a leading supplier of the keys.

The 2-inch long, 1.5-ounce DataSentry plugs into the printer port of your IBM PC or compatible, and it lets you add copy protection to individual files or even to entire directories. Rainbow Technologies claims that DataSentry does not interfere with the operation of your printer, which plugs into the other end of DataSentry. And I found that to be true.

Since I don't have any company secrets on my computer, I decided to protect the next best thing: my résumé. After I plugged DataSentry into my system's parallel port, all I had to do to complete the process was to copy a couple of utilities to my disk and type SEAL, followed by the filename of my résumé.

DataSentry then encrypted my file, producing a new file

that was also compressed to nearly half its original size. The utility also erases the original file. To make things even more secure, it goes beyond the normal MS-DOS DELETE (which leaves the data on the disk) by completely replacing the original data with nonsense characters.

When I removed DataSentry and attempted to edit the file, all I had was a screen

full of incomprehensible gibberish. To get my résumé back, I had to reinsert DataSentry and type OPEN and the filename. And my file came back.

You can even add a password when you seal a file. But without DataSentry in the parallel port, there's virtually no way to access the file unless you have a degree in cryptography and access to a super-computer.

The basic DataSentry uses what Rainbow Technologies calls a "proprietary algorithm" to encrypt your data. There's also a version that uses the government's highly secure Data Encryption Standard, but it can't be sold or exported beyond the U.S.

DataSentry is not completely transparent. You have to remember to reseal your files after you're done working with them. And if you take DataSentry home with you at night and forget it the next morning, you're up the creek.

Besides the individual DataSentry keys, Rainbow Technologies also offers a multilevel system, so a department manager can have a key that will open the files of all employees. And you can even send encrypted files over telephone lines by purchasing keys with identical internal codes for use on both sides of the line.

If you lie awake nights worrying about the safety of your data, DataSentry will let you get some rest, especially if you put it under your pillow.

—Stan Miastkowski

continued



THE FACTS

DataSentry
\$125

Requirements:
IBM PC, XT, AT,
PS/2, or compatible with
a standard parallel
printer port and DOS 2.0
or higher.

Rainbow Technologies,
Inc.
18011-A Mitchell S
Irvine, CA 92714
(714) 261-0228
Inquiry 1038.



The journey to discovery can sometimes be a long and arduous one.

Especially when it comes to writing database applications.

And especially when you're not a programmer.

All of which is precisely why we built dBASE IV™ with an innovative new feature we call the Control Center.

The Control Center is a logical, intuitive window from which you perform all your key database operations. A constant frame of reference, if you will, for harnessing all of dBASE IV's formidable power.

Through the Control Center, you get simple and understandable access to every one of dBASE IV's modules and functions. Like the powerful Report Writer. The Applications Generator. And much, much more. So that the time it takes to develop your applications can be drastically reduced.

You see, at Ashton-Tate we think that people tend to be more successful when they're able to see the opportunities for discovery right in front of them.

Want to see for yourself? Just visit your local authorized Ashton-Tate dealer for a demonstration, or call 800-437-4329* ext. 2934 for details on videotapes, demo disks, upgrades, and more.



INTRODUCING dBASE IV

Circle 16 on Reader Service Card (DEALERS: 17)

“It’s a whole lot easier when you can see what you’re doing.”



*In Colorado call (303) 799-4900. Trademark/owner: dBASE IV, Ashton-Tate, and Ashton-Tate Logo/Ashton-Tate Corporation. © 1989 Ashton-Tate Corporation. All rights reserved.

Want to save Time, Money,
& Headaches?



GET SUPERSOFT'S
SERVICE DIAGNOSTICS

All the software, alignment diskettes, parallel/serial wrap-around plugs, ROM POSTs and extensive, professional documentation to provide the most comprehensive testing available for IBM PCs, XTs, ATs and *all compatibles* under DOS or Stand Alone. No other diagnostics offers such in-depth testing on as many different types of equipment by isolating problems to the board and chip level.

NEW: SuperSoft's **ROM POST** performs the most advanced **Power-on-Self-Test** available for system boards that are compatible with the IBM ROM BIOS. It works even in circumstances when the Service Diagnostics diskette cannot be loaded.

NEW: 386 diagnostics for hybrids and **PS/2s!**

For over nine years, major manufacturers have been relying on SuperSoft's diagnostics software to help them and their customers repair microcomputers. End users have been relying on SuperSoft's Diagnostics II for the most thorough hardware error isolation available. Now versions of Service Diagnostics are available to save everyone (including every serious repair technician) time, money, and headaches in fixing their computers, even non-IBM equipment.

All CPUs & Numeric Co-processors	All Color Graphics & Monochrome
System Expansion & Extended Memory	Monitors
Floppy, Fixed & Non-standard Disk Drives	Parallel & Serial Ports
Standard & Non-standard Printers	Mono, CGA, Hercules & EGA
System Board: DMA, Timers, Interrupt,	Adapters
Real-time Clock & CMOS config. RAM	All Keyboards & the 8042 Controller

Join the ranks of XEROX, NCR, CDC, SONY, PRIME, ... who have bundled SuperSoft's diagnostics with their microcomputers at no risk because of our 30 day money back guarantee.

Service Diagnostics for PC, PC/XT, and compatibles only.....	\$169
Alignment Diskette for PC, PC/XT and compatibles (48 tpi drives).....	\$ 50
Wrap-around Plug for PC, PC/XT and compatibles (parallel and serial).....	\$ 30
Service Diagnostics for AT and compatibles only.....	\$169
Alignment Diskette for AT and compatibles (96 tpi drives).....	\$ 50
Wrap-around Plug for AT (serial).....	\$ 15
ROM POST for PC, PC/XT and compatibles only.....	\$245
ROM POST for AT and compatibles only.....	\$245
Service Diagnostics: The KIT (Includes all of the above—save \$502).	\$495
Service Diagnostics for 386 or V2, V30, or Harris, etc. (please specify).....	\$195
Diagnostics II is the solution to the service problems of users of all	
CP/M-80, CP/M-86 and MS-DOS computers.....	\$125
ROM POST for PS/2 and compatibles only.....	\$245
Alignment Diskette for PS/2 and compatibles (3.5 inch).....	\$ 50

To order, call 800-678-3600 or 408-745-0234
FAX 408-745-0231, or write SuperSoft.

your microcomputer repair solution

SuperSoft

FIRST IN SOFTWARE TECHNOLOGY P.O. Box 611328, San Jose, CA 95161-1328 (408) 745-0234 Telex 270385

SUPERSOFT is a registered trademark of SuperSoft, Inc.; CDC of Control Data Corp.; IBM PC, AT & XT of International Business Machines Corp.; MS-DOS of MicroSoft Corp.; NEC of NEC Information Systems, Inc.; PRIME of PRIME INC.; Sony of Sony Corp.

A FORTRAN for the Mac Forces

Language Systems **FORTRAN** is a compiler that runs under the Macintosh Programmers' Workshop. You can purchase the MPW Unix-like shell from Language Systems configured to run the compiler, or you can use the MPW version from Apple with the Install program that is included with the FORTRAN compiler.

The compiler produces object code that is linked using MPW's linker, which can also link resources created by the Rez tool. This method lets the programmer use resources from within the program that have been previously created and debugged, resulting in significant savings in time and development effort.

Using FORTRAN again was like going to a 20-year high school reunion. We hadn't been near it for a while, and we were curious to see how time had changed it. The compiler supports the ANSI 77 syntax, and it has extensions to it designed for the Mac. One of the most obvious is that there can be 31 significant characters in a name, as opposed to the ANSI 77 allowance of 6 characters. The ANSI 77 version allows only

72 characters per source code line (from the days when cards were 80 columns), but the compiler can take up to 255 characters per line (which makes sense for the Mac).

One of the annoying things about FORTRAN—also annoying in this implementation—is the assumption of a standard I/O stream. That is, the output of the program goes to a fixed window that has basic menus attached to it and a goAway box. The programmer can't change the output window without extra work with MPW itself (attaching extra menus, for example). If output from the program exceeds 1000 lines into the window, it is automatically saved into a labeled file.

Other supported I/O units include the keyboard and the printer. Thus, mouse movement can't be used in a program without the programmer doing the Toolbox calls and the necessary overhead in the program. Whether or not this is significant for the average FORTRAN program is debatable. But it does reduce the "Macishness" of the resulting program without extra work.

You can easily implement the structures necessary to use Macintosh formatted records and communicate with routines written in other languages, like Pascal.

The compiler seems to be designed to make the porting of previously written FORTRAN programs easy. This is commendable, especially for beginning programmers using the language from a standard educational text. But the programmer should not expect the language to add most of the standard Mac features automatically. It seems a way to make the existing body of FORTRAN code usable on a Mac, and it succeeds.

—D. Barker and Larry Loeb
continued

THE FACTS

Language Systems FORTRAN
\$295; \$200 without MPW

Requirements:
Macintosh Plus, SE, or II with 1 megabyte of RAM and a hard disk drive with at least 5 megabytes of free space.

Language Systems, Inc.
441 Carlisle Dr.
Herndon, VA 22070
(703) 478-0181
 inquiry 1039.



A funny thing happens when you go around solving other people's database problems.

People tend to think of you as somebody you're not.

But that's all right. Because with all due respect to those who develop applications professionally, the fact is that more and more everyday people are being encouraged to turn out more

and more everyday programs.

Of course, it helps if they have a tool like dBASE IV's Applications Generator.

The dBASE IV™ Applications Generator does pretty much what its name implies: it writes the necessary code to pull together all the elements of your application. So you can concentrate more on what you want to accomplish, and less on what you have to do to get there.

The Applications Generator is fully integrated with dBASE IV's new Control Center, too. So you get a simple, understandable way to access all

this power. Be careful, though—this combination just might turn you into a programmer.

Which actually may not be so strange after all.

Want to see what it feels like? Just visit your local authorized Ashton-Tate dealer for a demonstration, or call 800-437-4329* ext. 2934 for details on videotapes, demo disks, upgrades, and more.



INTRODUCING dBASE IV

Circle 18 on Reader Service Card
(DEALERS: 19)

“It’s kind of strange, really—all of a sudden people think I’m a programmer.”



*In Colorado call (303) 799-4900. Trademark/owner: dBASE IV, Ashton-Tate, and Ashton-Tate Logo/Ashton-Tate Corporation. © 1989 Ashton-Tate Corporation. All rights reserved.

Introducing the Smallest 80386 based PC Compatible Single Board Computer Only 4" x 6"



Quark/PC® II

- VGA® VidedColor LCD Controller
- SCSI Hard Disk Control
- Up to 4 Mbytes Memory and more

To order or enquire call us today.
Megatel Computer Corporation
(416) 745-7214 FAX (416) 745-8792

174 Turbine Drive, Weston, Ontario M9L 2S2

Distributors

Germany — V & C Computers (06071) 25666 FAX (06071) 5863
Italy & Southern Europe — NCS Italia (0331) 256-524 FAX
(0331) 256-018 U.K. — Densitron (0959) 76331 FAX (0959) 7107
Australia — ASP Microcomputers (03) 500-0628 FAX (03)
500-9461 Denmark — Ingeniørfirmaet (452) 440488 FAX (452)
440715 Finland — Digipoint (3580) 757 1711 FAX (3580)
757 0844 Norway — AD Elektronikk (02) 141290
Quark is a registered U.S. trademark of F. & K. MFG. Co. Ltd. VGA is a registered trademark of IBM Corp.

megatel

Protects while you type!



- Remains In Place while you use your computer.
- Avoids Costly Repairs. Protects delicate electronics from dust, spills, smoke, ashes, staples.
- Soft, Flexible, retains normal keyboard feel.
- Washable, Durable High-Tech Polymer lasts years.
- Hundreds of Models. SafeSkin is available for most PCs, laptops, workstations and clone keyboards.
- Office • Home • Factory • Classroom • Laboratory

List Price \$29.95. Please call or write for free color brochure. Dealer inquiries encouraged.

SafeSkin™

Keyboard Protector

Merritt Computer Products, Inc./4561 S. Westmoreland
Dallas, Texas 75237/(214) 339-0753 • Fax (214) 339-1313
In Canada call 1-800-663-1061

SHORT TAKES

Sourcer Magic Disassembles Machine Code

Assembly language programmers may think they have to work with stone-age computing tools, but **Sourcer** is a machine code disassembler with the interface of the best consumer-oriented programs and much of the built-in intelligence of an expert system.

A disassembler program reverse-engineers executable programs, producing assembly language listings or source code. You use it to study how programs work, to modify them, or to check them for viruses, improperly appropriated code, and inappropriate operations. Typically, the only control you have over a disassembler are the command-line options.

Sourcer has changed that; it has an options-setting screen that lets you select formats, comment types, analysis methods, and more than a dozen other options. The screen then displays an example of your selections as you make them. It even has a help screen! (This may not be extraordinary to the average user, but it is remarkable for an assembly language programming tool.) Having made your choices, you press G (for "Go"), and Sourcer displays the progress of the disassembly process in a graph at the bottom of your screen.

The input to Sourcer can be .EXE, .COM, .OBJ, or .BIN

multisegment files (up to 250 segments); device drivers; program overlays; system files (.SYS); or any RAM or ROM address in the first 1-megabyte area. Sourcer will disassemble code from the 8088/8086, 80186/80188, V20/V30, 80286 (privileged and real modes), 8087, and 80287 processors to the appropriate instruction sets.

Sourcer uses a multiple pass-data analysis/code-simulation sequence to separate code from data, analyze the code for BIOS calls, and analyze the data for strings. The output from Sourcer consists of source code or listing files. Because of the length of comments, you should use a 132-character printer to list the output files.

Disassembly of a 13K-byte DOS utility produced a 130K-byte .ASM file in 4 minutes (on a 10-MHz 80286 PC-DOS machine). An attempt to disassemble an EGA demonstration program produced: "WARNING: Packed file, conversion quality low." But it still managed to produce a usable listing, although it obviously had problems following the flow of the program.

Sourcer comes with a well-written 76-page manual that explains operation and warning/error messages. You can also buy an optional BIOS preprocessor.

—Ben Smith ■

THE FACTS

Sourcer
\$99.95; with optional
BIOS preprocessor,
\$139.95

Requirements:
IBM PC or compatible
with 512K bytes of RAM
and DOS 2.0 or higher;
supports CGA, EGA,
VGA, MDA, and
Hercules adapters.

V Communications
3031 Tisch Way
Suite 905
San Jose, CA 95128
(408) 296-4224
Inquiry 1050.



It's always the raw speed of an application that seems to catch one's attention. But when you think about it, speed alone doesn't always determine the amount of useful work you can produce.

That's why in dBASE IV,[™] we added more than just a blazingly fast .EXE compiler. We added a total of 310 new or enhanced commands and

functions that help you complete your applications in less time than you ever thought possible.

And without your having to become a full-fledged programmer to do it.

Of course, the compiler by itself lets you run applications significantly faster than is possible with dBASE III PLUS.[™] But you'll also find yourself working much more efficiently through dBASE IV's intuitive new Control Center. As well as by using its Applications Generator. Or the Report Writer. The Forms Generator. And much more.

After all, when it comes to developing dBASE IV applications more quickly, there's not just one way to do it.

There is one way to find out more, though. Just visit your local authorized Ashton-Tate dealer for a demonstration, or call 800-437-4329* ext. 2934 for details on videotapes, demo disks, upgrades, and more.

 **ASHTON · TATE[®]**

INTRODUCING dBASE IV

Circle 20 on Reader Service Card
(DEALERS: 21)

“Have you noticed that program speed is not the only reason you get things done faster?”



*In Colorado call (303) 799-4900. Trademark/owner: dBASE III PLUS, dBASE IV, Ashton-Tate, and Ashton-Tate Logo/Ashton-Tate Corporation.
© 1989 Ashton-Tate Corporation. All rights reserved.

Power



T5200: 20MHz 386 processor, 2 internal IBM[®] compatible expansion slots, VGA gas plasma display with VGA monitor port, 40MB or 100MB hard disk, 2MB RAM standard expandable to 8MB, 1.44MB 3 1/2" diskette drive.

At Toshiba, we're not only committed to making computers more portable, but also to making portables more powerful.

Which is why, in our effort to constantly improve and refine our machines, we've added three new computers to what is already the most complete family of truly portables available.

Each designed to be powerful enough to take on the increasingly complex tasks that face today's sophisticated PC users.

First, the T1600 which weighs under 12 pounds and which is the fastest battery-

powered computer we've ever made.

Second, the T3100e, the successor to our most popular machine—the T3100/20. We've made it nearly two pounds lighter and a lot faster—we've even added expansion capabilities. About the only thing we didn't add was more size.

T1600: Battery-powered 286/12MHz, coprocessor socket, 20MB hard disk at 27msec, 1.44MB 3 1/2" diskette drive, 1MB RAM expandable to 5MB, detachable backlit EGA compatible LCD, removable rechargeable battery pack.



Toshiba is the world leader in truly portable PCs and manufactures a complete line of high quality dot-matrix and laser printers. For more information call 1-800-457-7777. All Toshiba PCs are backed by the Exceptional Care program (no-cost enrollment required). IBM is a registered trademark of International Business Machines Corporation. Models T1600 and T5200 have not been approved by the Federal Communications Commission. These devices are not, and may not be, offered for sale or lease, or sold or leased until the approval of FCC has been obtained.

Surge.



And finally, the T5200, which has enough power to replace virtually any desktop PC.

But we haven't just concentrated on power and portability. We've also constantly looked for ways to make our machines more durable, more reliable, and easier to use—down to the 800 number our customers can call for help with any technical question that might come up.

We figure that's what our users demand.

And it's by anticipating the growing needs of our users that we have continually found ways to make our machines weigh

less and do more. So you can work wherever you want and however you want.

All of which might make it tempting for some people to abandon their desktop for the convenience of portability. Go ahead.

We've given you the power to do it.

T3100e: 12MHz 286 with 80287 coprocessor socket, internal half-length IBM slot, 20MB hard disk with 27 msec access, 1MB RAM expandable to 5MB, gas plasma display, 1.44MB 3 1/2" diskette drive.

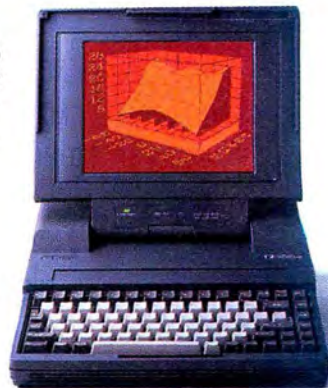

In Touch with Tomorrow
TOSHIBA

Toshiba America Inc., Information Systems Division

Circle 232 on Reader Service Card
(DEALERS: 233)

FEBRUARY 1989 • BYTE 107

BURN ALL YOUR COMPUTER BOOKS!



YES! YOU CAN NOW BURN ALL YOUR COMPUTER BOOKS AND STILL BE AN ACE PROGRAMMER!

GEYSER "ON-SCREEN REFERENCE BOOKS" ARE EITHER MEMORY RESIDENT OR STAND ALONE PROGRAMS. THEY POP UP INSTANTLY AND PUT ALL THE INFORMATION YOU NEED RIGHT AT YOUR FINGERTIPS!

WITH GEYSER "ON SCREEN REFERENCE BOOKS" YOU CAN NOW:

- ASK ANY QUESTION IN PLAIN ENGLISH USING ITS UNIQUE "PERSONAL WORD SEARCH" QUERY SYSTEM.
- GET THE EXACT SYNTAX AND USAGE OF ANY COMMAND BY USING THE "COMMAND REMINDER" WINDOW.
- SCAN THE ON-SCREEN BOOK BY TOPIC USING THE OVERVIEW FEATURE.

THE GEYSER COLLECTION INCLUDES THE FOLLOWING TITLES:

NOW AVAILABLE			
DOS	dBASE III PLUS	WORDPERFECT	LOTUS 1.2.3.
TURBO C	CLIPPER	WORDSTAR	
TURBO PASCAL		XYWRITE III PLUS	
MS FORTRAN			

AVAILABLE END OF MARCH 89			
PROLOG	REFLEX	SPF/PC	SYMPHONY
TURBO BASIC	DATAEASE	PFS/PROF. WRITE	QUATTRO
TURBO ASSEMBLER	dBASE IV	MS WORD	SUPERCALC
		DISPLAYWRITE	

AVAILABLE END OF APRIL 89			
XENIX	FOXBASE	WORDSTAR 2000 PLUS	EXCEL
ADA	R:BASE	MULTIMATE	MULTIPLAN
	PARADOX		FRAMEWORK

NO MORE ENDLESS PAGES FLIPPING.
NO MORE WASTED TIME SEARCHING.
NO MORE TRAIN-OF-THOUGHT DERAILMENT.

\$49.⁹⁵ WILL BUY YOU
FREEDOM FROM BULKY MANUALS.
ORDERS: 1-800-361-7273

EACH GEYSER ON-SCREEN REFERENCE BOOK IS AVAILABLE ON DISKETTE FOR ONLY \$49.95.

GEYSER ALSO HAS A CORPORATE CUSTOMIZATION SERVICE DIVISION THAT MAKES OUR LEADING EDGE TECHNOLOGY AVAILABLE FOR CUSTOMER SALES SUPPORT OR TRAINING. THIS DIVISION OF GEYSER CAN APPLY OUR UNEQUALLED ON-SCREEN HELP TO ANY KIND OF BOOKS, MANUALS OR CATALOGUES. FOR FURTHER INFORMATION CALL: (514) 842-5719.

Circle 97 on Reader Service Card

GEYSER INFORMATICS INC.

SYSTEM REQUIREMENTS: 640K RAM, A HARD DISK, IBM/XT, AT, 386 OR 100% COMPATIBLES AND PC-DOS OR MS-DOS VERSION 2.0 OR HIGHER.

TO ORDER: CALL TOLL FREE: 1-800-361-7273 CREDIT CARDS: AMERICAN EXPRESS - VISA - MASTERCARD

GENERAL NOTICE: THE PRODUCT NAMES USED HEREIN HAVE BEEN USED FOR IDENTIFICATION PURPOSES ONLY AND MAY BE TRADEMARKS OF THEIR RESPECTIVE COMPANIES.

Paradox 3: Neither Enigma nor Riddle

Borland's extensive upgrade of Paradox makes it a major contender for the number-one DBMS spot

What might be termed "the battle of the databases" has rapidly become a battle of major software companies. Though a flock of small-to-medium companies sells database managers, the major activity in "serious" relational database managers is pretty much confined to large companies with the commitment (read "bucks") to devote the time and resources needed to effectively develop these complex applications.

Ashton-Tate's dBASE, long considered the state of the art in database managers, is now in version IV. A measure of its acceptance is the flock of act-alike products nipping at its heels. In fact, as this was being written, Ashton-Tate filed a lawsuit against Fox Software, charging that its FoxBASE package violates the "look and feel" of dBASE.

But nobody can accuse Borland International's Paradox of being a dBASE clone. From a user-interface and design-philosophy standpoint, it's a unique animal; and that's where its power and versatility lie. Introduced in 1985, Paradox quickly became a serious contender in the high-end database manager market, especially after Borland acquired the package's original developer (Ansa Software). Borland brought considerable marketing clout to the equation, and with the release of version 3, the Paradox series has reached a point where it has the potential of overtaking dBASE IV.

Paradox 3 is a major upgrade from ver-

sion 2, with numerous enhancements and brand-new options. Like any relational database manager, it's feature-packed and extremely complex. We looked at the prerelease beta version of Paradox 3, and this First Impression will concentrate on its new and improved features. Although the version we discuss here didn't have it, Paradox's upcoming SQL (Structured Query Language) engine is a potentially significant development. (See the text box "Paradox Tests the SQL Waters" on page 110.)

QBE Gets Better

Paradox was the first PC-based software package to incorporate a true Query-By-Example approach to conducting database operations. And until recently, it was the only one. (The latest release of dBASE incorporates QBE, although we hadn't seen it at this writing.) IBM developed the QBE definition in the mid-1970s. Until Paradox appeared, QBE was used mainly in minicomputer and mainframe database applications.

In Paradox 3, QBE is the core of the user interface. By now, Paradox's table-based, fill-in-the-blanks approach to locating data is familiar to thousands of users. As QBE implies, performing a query involves giving examples in a query table. Paradox has always had a rich selection of query options, and version 3 has added a few more.

One of the major new features of Paradox 3 is the choice of how to join data that you query from multiple tables. With any relational database manager, a common problem with a query that takes data from several related tables is what to do with mismatches. When you join two or more tables, should records in one table with no matches in the other be included or excluded in a new table? Most database managers simply don't offer you a choice. They either always exclude the records, something called an *inner join*, or they always include them, which is called an *outer join*.

An inclusion operator in Paradox 3 now gives you the option of easily performing either an inner or an outer join. By default, Paradox, like most database managers, does an inner join of tables. But in Paradox 3, placing an exclamation point in the query tells the program to do an outer join. To be fair, it is possible to do outer joins with most database managers, but it requires several steps that are time-consuming and usually require more than a bit of programming skill.

In Paradox 3, Borland has extended the original QBE definition by including set operations. They add a collection of logical operations to a Paradox query. Because they allow you to perform highly complex queries in a single step, set operations are another step toward making Paradox 3 easier to use.

Creating sets is a simple matter of placing the keyword SET in the leftmost column of a query form. SET defines information about sets of records, which you can then compare with other data. The SET command works in conjunction with four new operators: ONLY, EVERY, EXACTLY, and NO. For example, in a typical order-entry system, you can use a one-line query to ask "Which products have been ordered *only* by customers in New Hampshire?" Paradox 3 also has an OR operator that lets you perform additional one-line queries such as "Who lives in California OR New York?" In prior versions, this required a second line in the query.

Another new feature, though minor, also adds to Paradox 3's usability. While you've always been able to perform calculations within a Paradox query, you had no control over what the new field in the resulting table was named. That problem has been solved with an AS operator that lets you name the new field.

Improving Relations

Although relational database managers have become an industry standard, they

continued

Paradox Tests the SQL Waters

One of the big promises of the networked computing environment of the 1990s is the marriage between local databases on personal computers and large databases on mainframes and minicomputers via the Structured Query Language. The idea is that users of local databases such as Paradox or dBASE will be able to issue queries in the "native language" of the database. Those queries are then translated into SQL and transparently transmitted to remote databases, where the query is processed and the data is retrieved and sent back to the local database. Ideally, the data on the remote database appears as just another table on the local database.

This type of transparent connectivity to SQL will offer some major advantages to database users in large organizations. It will be possible not only to centralize important data on the main-

frame or minicomputer, but also to allow users access to that data on their PCs with all their inherent advantages such as independent processing, graphical interfaces, and a large and flexible software base. Centralization will also greatly improve the security, consistency, and integrity of the organization's data.

Although it wasn't available in the beta version we tested, Paradox SQL connectivity was demonstrated by Borland at a recent industry trade show. The demonstration simultaneously accessed databases in Oracle's SQL, IBM's OS/2 Extended Edition, Novell's XQL, and the Sybase SQL Server.

Borland has developed a core SQL "engine" for Paradox that translates queries issued using the Paradox Query-By-Example feature. The user issues a QBE query. If a remote database is present, the Paradox SQL engine detects its

presence, translates the query into SQL, and sends it to the remote database. The result of the query appears on the PC as a Paradox Answer table.

Like most so-called standards, the leading versions of SQL now on the market are incompatible with each other. But these incompatibilities are apparently inconsequential to the SQL connectivity engine built into Paradox, which simply has different translators that handle the different versions of SQL.

Paradox users won't be aware of this process because the remote data will appear as a Paradox table regardless of the source of the remote database or its version of SQL. The Paradox SQL connectivity package will also include remote data entry into SQL databases and the "pass-through" of PAL (Paradox Application Language) syntax to SQL queries.

do have inherent problems. One typical difficulty is aptly named the "order-entry problem," because it manifests itself during the design of common order-entry databases. Designing a *single* form that enters a sales order, displays customer information, and lets you enter an unlimited number of items isn't as trivial as it sounds. The interrelationships between items can quickly become very complex.

Another problem of relational databases is what designers call *referential integrity*, which is making sure that explicit relationships between records are maintained. For example, a common goal is to make sure a customer record can't be deleted if that customer has an outstanding order.

Problems like these aren't insurmountable, but in most database management systems they require a great deal of programming knowledge to solve. Paradox 3 has added several new features to forms design that directly address these inter-table relations and dependencies.

The most important of these is the addition of multitable forms. A single form in Paradox 3 can now display data from multiple tables. Also added are linked tables within forms. For example, if you're using a form that uses multiple tables of data, you can link or unlink the tables. If you leave the tables unlinked, you can scroll through multiple tables in-

dividually on the form. But if you link the forms, the multiple tables remain related to each other. As you move through a database, Paradox 3 automatically keeps track of the interrelationships of the data. In a typical linked application, Paradox 3 won't let you delete a record when other records depend on it. This serves to eliminate the referential integrity problem.

Graphically Speaking

One long-awaited addition in Paradox 3 is its advanced graphics capabilities. While graphics are available in other database managers—either integrated into the package or as extra-cost additions—Paradox 3's graphics are singular in both ease of use and versatility. The program has a large selection of graph types, including the standard pie charts, line graphs, bar graphs, and *x,y* graphs.

Creating a graph is simple: You use Paradox's ROTATE command to rotate data columns into the order you want them to appear and then press a single key. Paradox 3 instantly graphs the data, choosing the type of graph that's most fitting for the type of data you're graphing. If you want to change the graph type or otherwise customize the graph, you have a full contingent of graphics menus.

Besides printing graphs on most printers, you can also export Paradox 3 graphs in a variety of industry-standard

graphics file formats for further work. And if you need to give presentations, a WAIT command within the program lets you create a "slideshow" of Paradox 3 graphs.

Crosstab Control

A new feature that's tightly coupled to Paradox 3's graphics capabilities is its crosstab function. The package's normal table view of data is usually the best way of organizing and viewing information. But especially when you want to graph data, a spreadsheet-type view of the data is more useful. The crosstab command instantly converts a standard table into a matrix-type spreadsheet view. For example, crosstab converts a table that contains customer names, item names, and amount sold into a new table with item names as column headers and counts in columnar format. The result of graphing this type of data is easier to interpret.

Depending on how you've organized your databases, crosstabs don't always improve graphs. However, the crosstab spreadsheet-type view is useful with Paradox 3's import/export features. To Paradox's 1-2-3 connection, Borland has conveniently added the ability to import data from its own Quattro spreadsheet.

Adding Color to Your Life

In previous versions, Paradox didn't use color very well, simply giving you a

PARADOX 3

white-on-blue display on a color monitor. But version 3 lets you use color effectively, indeed. You can specify colors for fields, forms, menus, and just about every other component of the program.

This can be more than a little useful. For instance, you can have negative numbers show up in red, highlight the most important parts of a form, or even highlight a current table image in a different color. Though it sounds trivial, Paradox 3's color control can help you make your applications easier to use and more intuitive.

Your Programming PAL

The Paradox Applications Language has always been one of the most powerful database programming languages in the business. And the version of PAL that comes with Paradox 3 has a host of enhancements, including new commands and additional arguments for existing statements. Space restrictions preclude our going into detail about them; but as you might expect, most of the added commands support Paradox 3's new features.

PAL, like the programming languages of Paradox 3 competitors, requires a goodly amount of programming experience to use effectively. Not coincidentally, it also requires a large time commitment to learn. Since PAL programming is essentially a full-time proposition, serious PAL programmers are likely to be found in large companies with a heavy commitment to Paradox. For the rest of us, the Personal Programmer is included with every copy of Paradox 3. Also updated for the new version, the Personal Programmer is an interactive applications generator that lets you create turnkey menu-driven custom applications.

Appearing on the Network

Last but not least in Paradox 3 are a few small enhancements to its multiuser capabilities. Ever since Paradox 2, the package has been one of the few off-the-shelf applications that easily handle networks with no modifications. Not surprisingly, all the enhancements and new features mentioned above also work on networks.

One intriguing application that uses Paradox 3's new graphics capabilities is the ability for a manager to use Paradox 3 on a network to monitor workflow. For instance, a system manager can use the package to graph data that other users are entering. And because Paradox 3 performs network updates in real time, the graphs will change as data is entered.

Paradox 3

Type
Relational database manager

Company
Borland International
1800 Green Hills Rd.
P.O. Box 660001
Scotts Valley, CA 95066
(800) 543-7543
(408) 438-8400

Format
Unavailable in beta version

Language
C

Hardware Needed
IBM PC, AT, XT, PS/2, or compatible with 512K bytes of memory, DOS 3.0 or higher, a hard disk drive, and one floppy disk drive. To display graphics, a CGA, EGA, VGA, or Hercules graphics adapter is needed.

Documentation
Unavailable in beta version

Price
\$725

Inquiry 1067.

The Contender

Individually, the enhancements to Paradox 3 are impressive. Taken together, they result in an exceptional database management system that has all the capabilities necessary for even the most advanced applications. Yet unlike most of its major competitors, Paradox 3 is intuitive enough so that it can be used for many applications without a large learning curve. Still, getting the most from Paradox does require a commitment to learning. But its extensive on-line help, coupled with a set of updated and rewritten manuals, makes that job far from arduous. Priced at \$725, Paradox 3 isn't exactly inexpensive, but it's comparable with other high-end, high-powered database management packages. With the release of Paradox 3, Borland now has a product that easily matches, and in some ways surpasses, the competition. ■

Stan Miastkowski is a BYTE contributing editor, director of K+S Concepts (a documentation and consulting firm), and editor of the "OS Report" newsletter. He can be reached on BIX as "stanm." Nick Baran is a BYTE technical editor based in San Francisco. He can be reached on BIX as "nickbaran."

IEEE-Z

IOtech has the widest selection of *easy-to-use* interfaces & software for IEEE 488 (GPIB/HPIB) systems.

- Instrument & plotter controllers (internal & external) for PCs, PS/2s, & Macintosh

- Converters from IEEE to RS-232/422, digital I/O, modem, real-time clock, SCSI, & analog I/O

- IEEE bus extenders via RS-422 or fiber-optics

- 512K IEEE data buffers & expanders

- Software for IEEE control from languages & Lotus 1-2-3®

- Menu-driven graphics & analysis software

- 30 day money-back guarantee

- 2 year warranty

- Call for your FREE Technical Guide



IOtech...the choice is easy

IOtech

(216) 439-4091 Telex 6502820864 Fax (216) 439-4093

25971 Cannon Road • Cleveland, Ohio 44146
London (0734) 86-12-87 • Paris (1) 34810178 • Zurich (01) 821 944
Milan (02) 4120360 • Linköping 013 11 01 40 • Amsterdam 01830-35333
Sidney (2) 452 3831 • Munich, and other European, North African, and Middle East countries not listed (089) 710020.

NATURAL LANGUAGE INTERFACE



THE COMPUTER CHRONICLES makes keeping up with the information age easy.

Stewart Cheifet and **Gary Kildall** are your co-hosts for a weekly half-hour television program aimed at computer users, owners, educators and computer industry professionals. If you're looking for help in finding out what's new and what's news, tune in to THE COMPUTER CHRONICLES every week on your local public television station.

The latest developments in personal computer hardware and software are discussed, demonstrated and reviewed. The industry's top developers, executives, analysts, and journalists keep you on the cutting edge of the computer business. Paul Schindler reviews new software and Wendy Woods goes on location to find out how users are taking advantage of new developments.

Topics this season include Local Area Network Software —Fax Boards—New Generation Spread-

sheets—Color Printers—SQL—Hard Disk Management—Hypertext—Display Technology—Programming Languages—PC Kits—Bus Wars—The Battle of the Operating Systems—Foreign Language Software—Artificial Intelligence—Neural Network Technology—Megahertz Mania—Software Piracy—Personal Information Management Software—Optical Storage—and much more.

Each week THE COMPUTER CHRONICLES looks at the top stories of the week in Random Access, a news segment designed to keep you informed about the latest developments in the computer industry.

THE COMPUTER CHRONICLES, a weekly half-hour of public television that just might be the help you need.

THE COMPUTER CHRONICLES IS NOW ON BIX

BIX, the Byte Information Exchange, now has a conference for The Computer Chronicles.

Now you can communicate directly with the staff of The Computer Chronicles to suggest topics for future shows or to request information or details on past shows.

Once on BIX, just type "COMP. CHRON" at the colon (:) prompt.

The Mac SE Takes Off

The newest version of the Mac SE runs rings around its predecessor

If you're interested in brute Mac power, but you lack the desk space or the credit line for a IIX, then the new Mac SE/30 may be just the machine for you. This newest Mac is a major addition to the Apple Macintosh product line. Featuring a 68030 CPU and a 68882 floating-point unit (FPU), the Mac SE/30 puts the heart of the Mac IIX into the body of a Mac SE. In fact, the only thing the Mac IIX has that the Mac SE/30 doesn't have is the NuBus expansion card cage.

The new machine is the latest in just one family of Macs. Apple now talks of a "modular" family of machines (which currently consists of the Mac II and IIX) and a "compact" family of machines (now headed by the Mac SE/30 and including the Mac Plus and SE). The Mac SE/30 bridges the gap between the high performance of the modular systems and the small footprint of the compact family. As you'll see, the Mac SE/30 is in fact just as powerful as any of the modular systems.

From the outside, the Mac SE/30 looks like any other Mac Plus or SE. But the internals of the machine represent a new design incorporating the performance features of the Mac IIX. The new logic board (see photo 1) sports a 16-MHz Motorola 68030 processor with a built-in memory management unit (MMU), just like the Mac IIX. The logic board also has the same single in-line memory module (SIMM) RAM chips as the Mac IIX, and it is expandable to 8 megabytes.



The Mac SE/30 also uses the same 256K-byte SIMM-mounted ROMs. This means that the Mac SE/30 can support Toolbox functions such as Color QuickDraw, although it comes standard with the familiar 9-inch built-in black-and-

white monitor. A new 32-bit expansion slot, however, provides an obvious opportunity to add color to the Mac SE/30.

A 16-MHz 68882 FPU comes standard, and so does the Apple Sound Chip

continued

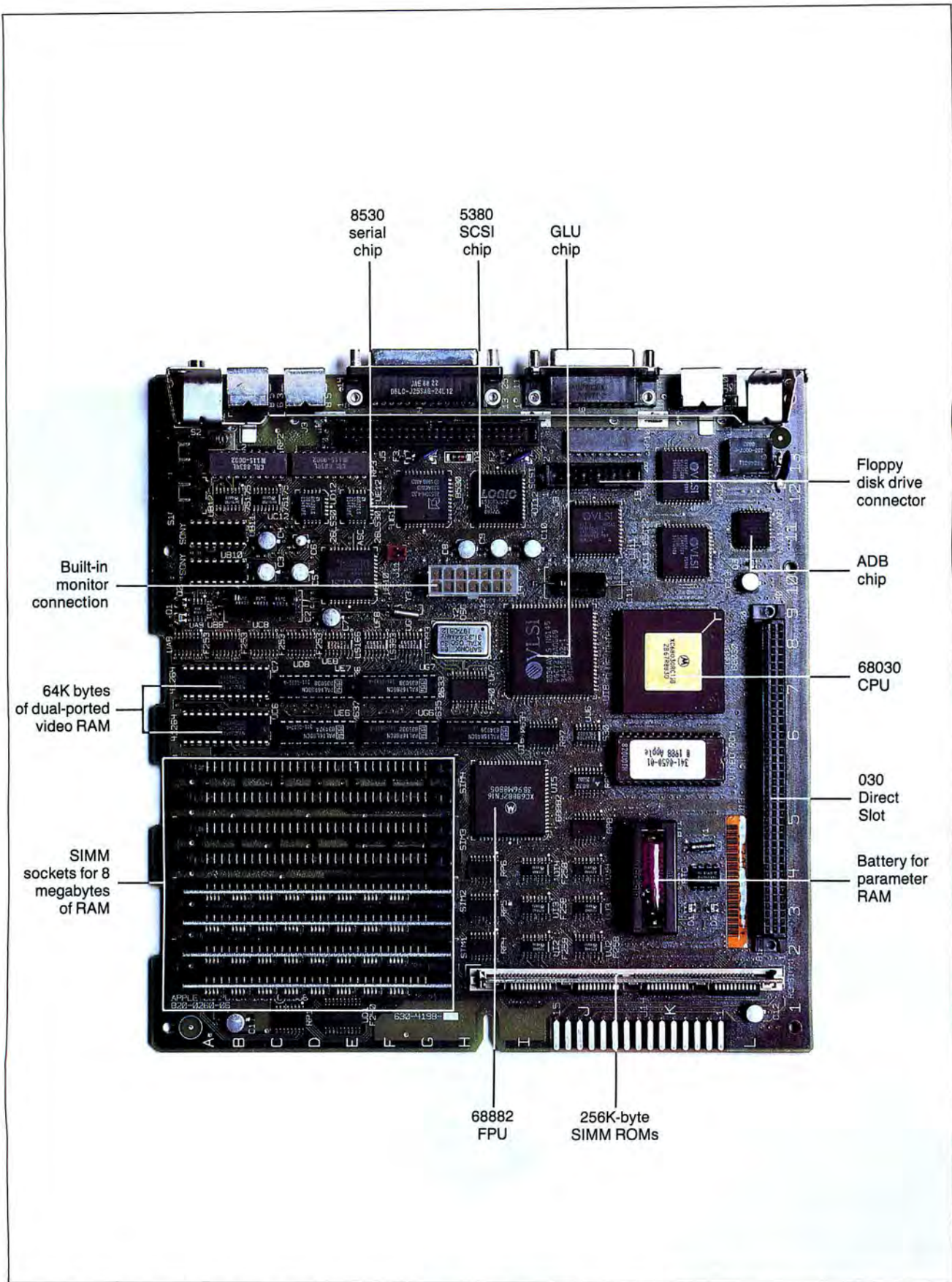

Photo 1: The new Mac SE/30 logic board features a 16-MHz 68030 CPU and a 68882 FPU. There's only one floppy disk drive connector on the board (the Mac SE has two). Note the SIMM-mounted ROMs and the 030 Direct Slot. Also note the 64K bytes of video RAM just above the SIMM RAM.

supporting four-voice stereo sound. The Mac SE/30 also features the new SWIM (Super Wozniak Integrated Machine) floppy disk drive controller chip, as well as the FDHD (which stands for "floppy disk high-density") floppy disk drive that reads MS-DOS- or OS/2-formatted disks as well as Apple II ProDOS disks. However, you still have to use the Apple File Exchange utility to transfer files from a foreign operating-system format to the Macintosh system.

And there's more. The Mac SE/30 features a single 32-bit expansion slot called the 030 Direct Slot. It is basically NuBus-compatible but has a different form factor so that NuBus cards won't fit. But Apple engineers told me that you can easily convert Mac II NuBus logic designs to the 030 Direct Slot and that you can use the same NuBus software drivers.

However, the 030 Direct Slot's 120-pin Euro-DIN connector is not physically compatible with either the 96-pin Mac II NuBus or the 96-pin Mac SE expansion slots. The Direct Slot is positioned vertically in the computer chassis, unlike the horizontal layout of the expansion slot in the standard Mac SE (see photo 2).

One other significant change from the standard Mac SE is the use of 64K bytes of separate dual-ported video RAM to control the internal monitor. Since this video RAM is connected directly to the CPU, there's no need for a video buffer in the memory subsystem. This means that main memory is not burdened with the additional task of controlling video I/O, unlike the Mac SE's memory subsystem. Specifically, in the original Mac SE design, the CPU had to interleave its memory accesses (three out of four cycles) with the video display circuits so that the Mac's screen could be drawn. This meant that the Mac SE's CPU could access memory only 75 percent of the time, which degraded system performance. The separate video RAM in the Mac SE/30 allows the 68030 processor to access memory at every cycle. This is a big win in performance, since applications execute in fewer cycles than with the previous video buffer system.

The basic interfaces in the Mac SE/30 remain unchanged from those of the Mac SE. The SE/30 has two Apple Desktop Bus connectors, two RS-232C/RS-422 serial ports, and a SCSI connector rated at the same transfer rate as the one in the standard Mac SE: 172K bytes per second for polled transfers, and 656K bytes per second for blind transfers.

Along with the Mac SE/30, there is a
continued



Photo 2a: The cramped insides of the Mac SE/30.



Photo 2b: The expansion board mounts vertically in the chassis. In the original Mac SE, the expansion board mounted horizontally under the main logic board.

Table 1: According to the version 1.2 BYTE Benchmarks, the new Mac SE/30 outperforms the Mac SE and the Mac II, and it approaches the performance of (and in some cases, even outperforms) the Mac Ix, with which it shares a common coprocessor. All times are in seconds.

Test	Mac SE/30	Mac SE	Mac II	Mac Ix
CPU				
Matrix	16.4	69.2	21.2	17.1
Sieve	31.7	170.2	40.2	31.3
Sort	29.5	154.1	44.2	29.5
String move				
Byte-wide	82.1	373.6	93.9	82.1
Word-wide	42.1	186.8	45.6	42.1
Doubleword	22.9	121.3	22.9	22.8
Disk I/O				
SubFinder Seek				
SCSI				
(1 block)	16.6	28.3	16	13.9
(32 blocks)	154.3	185.9	35.7	35.6
File I/O				
Seek	0.2	0.6	0.2	0.1
Read (seconds/K byte)	0.02	0.049	0.02	0.021
Write (seconds/K byte)	0.01	0.044	0.01	0.014
Large file				
Write	4.3	11.8	5.2	4.3
Read	4.8	8.4	4.8	4.7
Video				
Text				
Text edit	5.7	16.3	5.6	4.7
Draw string	2.4	3.9	1.8	1.6
Graphics				
Small-C	44.6	80.9	57.7	52.8
QuickDraw	0.3	1.2	0.3	0.3
Floating Point				
Math	147.6	891.3	175.3	151.5
Trapezoidal rule: sine(x)	73.3	598.0	84.8	72.7
Trapezoidal rule: e ^x	97.9	720.7	112.5	96.6

new version of the System software—version 6.0.3. This new version includes some fixes to the FDHD driver and to the Apple File Exchange, allowing a wider tolerance for MS-DOS-formatted disks. For current Mac users, unless you use the Apple File Exchange, there is no reason to upgrade to version 6.0.3.

Pricing and Configurations

The Mac SE/30 is available in two configurations: either with 2 megabytes of RAM and a 40-megabyte hard disk drive, or with 4 megabytes of RAM and an 80-megabyte hard disk drive. Both configurations come with the 68882 FPU. Both hard disk drives have an average access time of less than 30 milliseconds, according to Apple engineers.

The Mac SE/30 with 2 megabytes of RAM and the 40-megabyte hard disk drive will cost \$5069, according to Apple. As we go to press, Apple says the

4-megabyte version with the 80-megabyte hard disk drive will cost \$6369. As with most Apple pricing structures, neither of these configurations includes a keyboard.

Upgrades

Apple plans to offer upgrades for current Mac SE owners. You will be able to upgrade either to a new logic board with 1 megabyte of RAM or just to the FDHD disk drive and SWIM chip disk drive controller. Note that you will not be able to use the 150-nanosecond memory from your old Mac SE in the new Mac SE/30, since the SE/30 requires the faster 120ns RAM used on the Mac II.

You can bet that the upgrade price for the logic board will make you think twice. It may actually be cheaper to sell your standard Mac SE and then buy a new Mac SE/30 than it would be to upgrade. At the time of this writing, Apple

had not set price or availability for upgrades, though the company says it expects to have the upgrades available in March.

Performance

Although I had limited time to work with the new machine, I was able to run the BYTE benchmarks on a Mac SE/30 at Apple's headquarters. The machine I tested had a 40-megabyte hard disk drive and 8 megabytes of RAM. Table 1 shows the BYTE benchmark (version 1.2) results of the SE/30 compared with those for a standard Mac SE, a Mac II, and a Mac Ix. As you can see, the performance of the SE/30 is comparable to a Mac Ix and in some cases exceeds it. Clearly, this machine is in a whole different league than the standard Mac SE.

In particular, note that processor-intensive tests, such as the Sieve, String Move, and floating-point tests, show the SE/30 sometimes outperforming the standard SE by almost an order of magnitude. To be fair, I should note that the standard SE does not have an FPU. Disk read/write operations are also faster, since the Mac SE/30 uses higher-speed hard disk drives.

So Why Buy a Mac II?

This is the obvious question. The Mac SE/30 offers essentially the same features as a Mac Ix. The only real difference is that the Mac II and Ix have six NuBus expansion slots. You can expect to see lots of Mac IIs operating as network file servers with Mac SEs and SE/30s as nodes on the network.

The other difference is that Apple does not plan to support A/UX on the Mac SE/30. So if you want to run Unix, you'll have to buy a Mac Ix, unless you're willing to try running an unsupported version of A/UX on the Mac SE/30. Since the SE/30 uses the same CPU, MMU, and ROM as the Mac Ix, there is no reason why A/UX would not run on it. It's just that Apple won't support it.

The Mac SE/30 is a very attractive machine. It's expensive, but it brings truly high-performance capabilities to the "compact" Macintosh product line. It essentially puts the power of a Mac Ix within the small footprint of the Mac Plus/Mac SE family. In fact, it's so attractive, I wonder how close Apple came to giving it a different name—one more in keeping with the Mac Ix: the Mac SEx. ■

Nick Baran is a BYTE senior technical editor based in San Francisco. He can be reached on BIX as "nickbaran."

Tandy® Computers: The broadest line of PCs in America.



The Tandy 1400 LT

The affordable
MS-DOS® based
portable
computer.

Here's a portable computer that's a true IBM® PC compatible. With a removable rechargeable battery pack built in, the Tandy 1400 LT is perfect for people on the go—like busy executives, sales personnel and journalists. Or use it like a desktop computer.

The Tandy 1400 LT features a high-resolution *backlit* liquid crystal display. The 80-character by 25-line resolution gives you the same quality of display as a full-sized monitor. And it's remarkably clear, thanks to the latest in "supertwist" LCD technology.

The 8088-equivalent microprocessor has a 7.16 MHz clock speed (vs. 4.77 MHz for most other PC-compatible portables). Standard equipment includes two 720K 3 1/2" built-in disk drives and 768K RAM—ample memory to run today's powerful MS-DOS based programs.

The Tandy 1400 LT also includes a parallel printer adapter, RGBI color monitor output, a real-time clock and an RS-232C serial interface. You even get MS-DOS and GW-BASIC at no extra charge.

Come to your local Radio Shack and see the Tandy 1400 LT.

**Send me a 1989
RSC-20 computer catalog**

Mail to: Radio Shack, Dept. 89-A-667
300 One Tandy Center, Fort Worth, TX 76102

Name _____

Company _____

Address _____

City _____ State _____

ZIP _____ Phone _____

Tandy Computers: Because there is no better value.™

MS-DOS/Reg. TM Microsoft Corp. IBM/Reg. TM IBM Corp.

Radio Shack®
The Technology Store™

A DIVISION OF TANDY CORPORATION

Circle 194 on Reader Service Card

Introducing the fastest possible way to create the fastest MS-DOS programs possible.

For Personal Computers Running the MS, OS/2 or MS-DOS Operating System.

Microsoft C 5.1

Optimizing Compiler

```

File View Search Run Watch Options Language
0) i : 217
1) p : 23383:5936
125:      int  i
126:
127:      set_cursor
128:      p = scrnbuf;
129:
130:      /* Draw top of box. */
131:
132:      *p = 218;
133:      p += 2;
134:      for (i = 0; i < COLS; p += 2, i++)
135:          *p = 196;
136:      *p = 191;
137:      p += 2;
138:
139:      /* Draw side of box. */
    
```

Now includes OS/2 systems support!

Microsoft

Microsoft C Optimizing Compiler 5.1 Techbox

Compiler

- Optimizations that generate the fastest code for DOS and OS/2 systems.
 - In-line code generation.
 - Loop optimizations.
 - Elimination of common subexpressions.
- Full OS/2-system support to break the 640K barrier. New.
 - Family API programs that run under DOS and the OS/2 systems. New.
 - Write multithreaded programs and Dynamic Link Libraries. New.
- Small, medium, compact, large, and huge memory models.
- Mix models with NEAR, FAR, and HUGE keywords.
- Fast compilation (10,000 lines/minute) with Microsoft QuickC.[™]
- Fastest math, in-line 8087/80287 instructions, and floating-point calls.
- More complete support of proposed ANSI standard.
- Over 350 library functions, including a graphics library.

Microsoft CodeView

- Full OS/2 systems support. New.
 - Debug applications of up to 128 MB under the OS/2 systems. New.
 - Debug multithreaded programs and Dynamic Link Libraries. New.
- Source-level debugging for precise control over programs.
 - Dynamic breakpoints in the source.
 - Debug programs written in a variety of Microsoft languages. New.
 - Full symbolic display of C structures. New.
 - Interactively follow linked lists and nested structures. New.
 - Watch variables, memory, registers, and flags.

Other Utilities

- Fast linking (twice as fast as the C 4.0 version linker).
- OS/2 incremental linker—up to 20 times faster than a full link. New.
- OS/2- and MS-DOS reconfigurable programmer's editor. New.

Everything about Microsoft® C Optimizing Compiler version 5.1 is dedicated to the professional programmer.

Fast code. Fast development. Fast debugging. And full support for both MS-DOS® and the OS/2 systems in a single package.

There's no faster C code on a PC, because powerful optimizations, such as in-line code generation and loop enregistering, generate executables that are compact and efficient. The documentation even teaches

you special coding techniques to squeeze every last bit of speed out of your code.

Fast code isn't all you get. Under MS® OS/2, the 640K barrier is gone so you can write C programs as large as a gigabyte. You can call the operating system directly. Create more responsive programs (multiple threads allow program operations to overlap). And build Dynamic Link Libraries (DLLs) that can be shared, saving valuable memory. DLLs also allow your main programs to be smaller, so they load faster.

Introducing the fastest possible way to create the fastest MS OS/2 programs possible.

For Personal Computers Running the MS-DOS or MS-DOS Operating System

Microsoft C 5.1

Optimizing Compiler

The screenshot shows the Microsoft C 5.1 compiler interface. The main window displays C source code for a program that draws a box. The code includes variable declarations for 'i' and 'p', and a loop that increments 'p' and 'i'. A 'Watch' window is open, showing a list of variables and their current values: 'i' at 217 and 'p' at 23383:5936. The Watch window has a menu with options: 'Add Watch...', 'Watchpoint...', 'Tracepoint...', 'Delete Watch...', and 'Delete All Watch'. A red circular callout points to the Watch window, stating: 'Special offer. Programmer's editor and Microsoft QuickC compiler included. FREE!'

```

File View Search Run Watch Options Language
0) i : 217
1) p : 23383:5936
125:      int i
126:
127:      set_cursor
128:      p = screnbuf;
129:
130:      /* Draw top of box. */
131:
132:      *p = 218;
133:      p += 2;
134:      for (i = 0; i < COLS; p += 2, i++)
135:          *p = 196;
136:      *p = 191;
137:      p += 2;
138:
139:      /* Draw side of box. */
    
```

Now includes OS/2 systems support!

Microsoft

Microsoft C Optimizing Compiler 5.1 Techbox

Compiler

- Optimizations that generate the fastest code for DOS and OS/2 systems.
 - In-line code generation.
 - Loop optimizations.
 - Elimination of common subexpressions.
- Full OS/2-system support to break the 640K barrier. New.
 - Family API programs that run under DOS and the OS/2 systems. New.
 - Write multithreaded programs and Dynamic Link Libraries. New.
- Small, medium, compact, large, and huge memory models.
- Mix models with NEAR, FAR, and HUGE keywords.
- Fast compilation (10,000 lines/minute) with Microsoft QuickC™.
- Fastest math, in-line 8087/80287 instructions, and floating-point calls.
- More complete support of proposed ANSI standard.
- Over 350 library functions, including a graphics library.

Microsoft CodeView

- Full OS/2 systems support. New.
 - Debug applications of up to 128 MB under the OS/2 systems. New.
 - Debug multithreaded programs and Dynamic Link Libraries. New.
- Source-level debugging for precise control over programs.
 - Dynamic breakpoints in the source.
 - Debug programs written in a variety of Microsoft languages. New.
 - Full symbolic display of C structures. New.
 - Interactively follow linked lists and nested structures. New.
 - Watch variables, memory, registers, and flags.

Other Utilities

- Fast linking (twice as fast as the C 4.0 version linker).
- OS/2 incremental linker – up to 20 times faster than a full link. New.
- OS/2- and MS-DOS reconfigurable programmer's editor. New.

You can even write a single Family API program that runs under both MS-DOS and MS OS/2.

Microsoft Editor is the first reconfigurable text editor for programmers that lets you develop under MS-DOS and MS OS/2. Under MS OS/2, multitasking lets you edit one file while you compile another, which cuts development time. You can even generate multiple compiles that report errors directly back into your source code.

Microsoft CodeView® is the highly acclaimed

window-oriented source-level debugger that makes debugging fast and efficient. You can view program execution while you watch variables and register values change. And under MS OS/2 you can debug multithreaded applications, DLLs, and programs as large as 128 MB.

New Microsoft C Optimizing Compiler 5.1 for the professional programmer. It's all the speed you need. Call (800) 541-1261, **Microsoft** Department I53.



The Only Character Recognition System That Outperforms Ours.

Consider the facts:

Nature's character recognition system can be trained to read all characters and languages it sees. **SPOT** (Flagstaff Engineering's Optical Character Recognition program) is trainable too. It reads most printed documents in English and more than 130 other languages.

Like nature's original, **SPOT** is very discerning. It can glance over an entire page or zoom in on a few lines of text. **SPOT** can read newspapers, magazines, books, manuals, invoices, contracts, government documents and much, much more.

Your eyes are teamed up with that marvelous computer, the brain. **SPOT** uses the latest man-made personal computers in conjunction with the

most popular low-cost scanners, and requires no additional hardware.

SPOT's advanced logic closely approximates what the human eyes and brain do. That's why **SPOT** will continue to be *the leader in OCR ...* with an intuition inspired by the original.

Seeing is believing. Since 1982, Flagstaff Engineering has helped thousands of international customers read information from various computer and printed media. Demonstration programs are available. Call today.



Helping People Read a World of Information

1120 Kaibab Lane • Flagstaff, AZ 86001
602-779-3341 • FAX 602-779-5998



Circle 89 on Reader Service Card for
S.P.O.T. 3.0 Version
90 for 9 Track Tape Up-Date
91 for Disk Conversion Systems Up-Date
92 for DEALERS only



Stalking new hardware and software, Jerry prowls the halls of COMDEX

I am just back from COMDEX. Naturally, I didn't want to turn in my column before I went, meaning that it's very late now and has to be on the wire by dawn, meaning that I'm not going to have much time for testing either hardware or software. It's all right, though. While I normally talk about little that I haven't actually got up and running at Chaos Manor, I use different rules for show reports.

Also, I got a fair amount of stuff tested before I went to Las Vegas. There's no lack of stuff to write about: my "ready line" is overloaded.

Gray Scales

It used to be that lots of major players used COMDEX as the stage for announcing spectacular new products. After a while, there were so many that I never had time to see them all. All we journalist types had the same problem, and when we'd get together in the pressroom we'd try to compare notes, but it was futile. Something important would be overlooked. Maybe a lot of somethings. A number of companies noticed this and decided that COMDEX was a lousy time to announce anything really new. New product announcements nearly vanished.

However, a few outfits have cottoned on to the idea that no one announces at COMDEX anymore, so although there weren't many new product announcements this year, there were a few.

The most exciting new hardware I saw this year was Intel's Visual Edge printing-enhancement system. This is a pair of boards—one for your IBM PC AT compatible (or 80386), the other for your

READY LINE OVERLOAD

Hewlett-Packard LaserJet II—plus cable and software. Put it all together, and you can do halftone printing from Page-Maker, Snapshot, Ventura Publisher, Publisher's Paintbrush, and a bunch of other desktop publishing programs.

The result as demonstrated at COMDEX is pretty spectacular. Visual Edge gives you 64 levels of gray at 70-line-per-inch resolution, and the hardware printed a large, complicated picture in about 3 minutes. Intel's press kit includes a bunch of pictures reproduced on a good-quality (19 gray levels) copier, and the same pictures scanned with a 256-gray-level Microtek scanner, then printed with a LaserJet II with Visual Edge. Believe me, you won't have any trouble figuring which is which. The press kit says Visual Edge gives a 300 percent improvement, and it looks about like that to me.

You can also get 37 levels of gray at 100 lpi, when resolution is more important than tone and shading.

You'll need expanded memory to use Visual Edge: 1 megabyte for $\frac{1}{8}$ page, and 4 megabytes for a full page. Of course, you need expanded memory to get much good out of any desktop publishing program. Obviously, Intel would like to sell you a genuine Above Board to supply it, and certainly that's as good a way to go as any. The good news is that since Visual Edge uses your computer's memory to stoke graphics into the LaserJet II, you can use the printer's memory to hold downloaded fonts. Visual Edge also speeds printing up by anywhere from 200 to 400 percent.

All told, Visual Edge adds a whole new dimension to desktop publishing. I don't recommend products I've seen only at shows, but if you're really interested in desktop publishing under DOS, you really ought to have a look at this.

Logic Gem

Most of the big companies come to COMDEX. At great expense, they fill the main convention hall; booths have

been getting larger and larger, probably because COMDEX lets *big* booth buyers have first choice on location. (I wandered into a room where they were coordinating booth allocations for next year, and I discovered that it's really a very complicated affair requiring quite a few people and a lot of communications, much like an auction that goes on over 3 days. Somebody ought to do a story on it.)

Anyway, you get your turn choosing COMDEX space both by booth size and by the number of years you've been coming (and if you ever drop out, you have to start over). This means that the big, long-established companies tend to fill the main exhibition hall. New companies are sent to outlying areas, like the Bally (formerly MGM) Grand.

This year, some new companies were put in a place called Cashman Field, which is somewhere near downtown Las Vegas. I met only one press person who ever *found* Cashman Field, much less went there. Certainly I didn't. I hear rumors that next year, simultaneously with COMDEX, they'll have MACDEX, a show devoted entirely to Macintosh computers and products, and that MACDEX will be at Cashman Field. I've always wondered if Apple truly wants to fence their machines and users off from the rest of the microcomputer community. Possibly this will do it for them. It might also put them down where they'll be visited only by the Little Sisters of the Poor. We'll see.

Anyway, since most of the start-up companies tend to be put into the Bally Grand, I generally find it worthwhile to spend a day there, and more often than not I find that the most interesting day of the show. This time was no exception.

The most exciting software at COMDEX was called Logic Gem, published by Sterling Castle Software (and yes, I know that the one in Scotland is Stirling Castle). They didn't have a copy for me to bring home (for the standard reason:

continued

"The documents are being printed"), so I haven't tested it here; but assuming that it performs as I saw it demonstrated, Logic Gem is going to change the way we write programs.

Logic Gem lets you make up a table of all sorts of conditions: data types (is this an integer?), keyboard input characters (is there input, and if so, is it a backspace character?), Booleans (is this condition true?), variables (is variable FOO greater than variable BAR?), or indeed almost

anything you like. You can then add outcomes: beep, go get an input character, exit loop, look for a disk file, and stuff like that. These go into another table.

Once that's done, the program generates all the possible logical sequences of the conditions you added and generates a new table. You can then couple conditions with outcomes. For a simple example, if there is an input character, and it is not numeric and not a backspace, beep and go get another input character;

otherwise, exit from the loop.

When you've set up all the outcomes you want with the conditions that should make them happen, the program generates the rules. You can edit these rules until you have things the way you want. If your edit produces a logical inconsistency, the program warns you. When you're finished, Logic Gem will generate commented source code in C, structured BASIC, Pascal, dBASE, FORTRAN, or natural language (English). You can incorporate the source code into a larger program and compile it.

According to Sterling Castle's literature, the natural-language output "is ideal for program documentation." From the demonstrations I saw, I'd say it would be fine to put into an appendix, but I sure wouldn't want to spend a lot of time *reading* that. On the other hand, I prompted them to make up some tables, then examined the Pascal and structured BASIC code generated, and it looked fine to me. Even the comments made sense.

I've just finished doing some programming for Mrs. Pournelle's reading program, and I often got complicated IF THEN... ELSE IF constructs wrong. I expect everyone does. That isn't supposed to happen if you're using Logic Gem, since it generates code to do exactly what you want and nothing else.

If that weren't enough, Sterling Castle claims that Logic Gem can also generate code to "collect optimization statistics for frequency of logic use and user-defined cost functions. These results may then be fed back into the logic compiler to generate more efficient code."

I've always said that the future of programming lies in figuring out *what* you want the computer to do, not *how* to make that happen, because as machines get more powerful, we'll develop more and better tools that can get the machines to do anything we want them to do. If Logic Gem works as I saw it demonstrated—and I have no reason to suppose it won't—it will be a real step toward the future I predicted.

DESQview 386

Quarterdeck's DESQview, for those few who don't know, is a multitasking program that lets you run several of your present DOS programs at once. The way I use it, DESQview doesn't quite do that; except for communications, I don't run programs in background, because I don't do long compilations or spreadsheet recalculations. However, I do like to keep a whole flock of programs and utilities in

continued

ARE YOU STILL DRAWING FLOWCHARTS BY HAND?

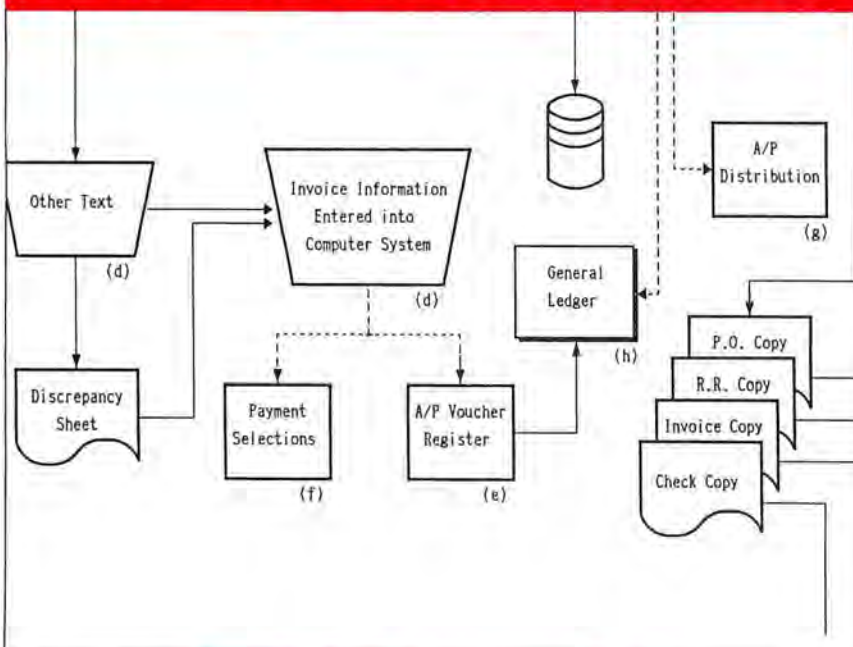

FLOW CHARTING II+

Flow Charting II+ will *amaze* you with its speed, power and simplicity.

- Update and print charts as fast as the situation changes
- See your revisions right away—no long wait for charts to be hand drawn
- Select 26 standard shapes; 10 text fonts
- Tutorial manual makes learning easy
- Runs on IBM or compatibles
- Produces excellent organizational charts!
- Only \$229!

PATTON & PATTON

Software Corporation

Excellence in charting the flow of ideas

For more information, see your local retailer or call
 1-800-525-0082, ext. 47 (outside Calif.) 408-629-5376 (Calif./Int'l.)
 81 Great Oaks Blvd., San Jose, CA 95119

THE NEW STANDARD FOR HIGH PERFORMANCE STATISTICAL SOFTWARE

CSS

COMPLETE STATISTICAL SYSTEM

WITH DATA BASE MANAGEMENT

AND GRAPHICS

A powerful, comprehensive, elegant, and super-fast statistical package for IBM (PC, AT, PS/2) and compatible computers. ■ The CSS optimized user interface with fast hierarchical menus incorporates elements of artificial intelligence; even complex analyses require only a few keystrokes (batch processing is also supported). ■ CSS features comprehensive, state of the art implementations of: *Basic statistics, Multi-way frequency tables, Nonparametric statistics, Exploratory data analysis with analytic graphs, Multiple regression methods, Time series analysis with modeling and forecasting (incl. full ARIMA), General ANOVA/ANCOVA/MANOVA, Contrast analysis, Discriminant function analysis, Factor analysis, Principal components, Multi-dimensional scaling, Item analysis/Reliability, Log-linear analysis, Cluster analysis, Non-linear estimation, Logit/Probit analysis, Canonical analysis, Survival and Failure Time analysis (Censored data), Quality Control analysis, and much more.* ■ All statistical procedures are integrated with fast data base management and instant, presentation quality graphics (over 100 types); full support for all mono and color graphics boards (incl. VGA) and over 100 plotters and printers (incl. the HP and Postscript standards). ■ All CSS screen output is displayed via customized Scrollsheets™ (i.e., dynamic, user controlled, multi-layered tables with cells expandable into pop-up windows); all numbers in a Scrollsheet™ can be instantly converted into a variety of presentation quality graphs; contents of different Scrollsheets™ can be instantly aggregated, combined, compared, plotted, printed, or saved. ■ The flexibility of the CSS input/output is practically unlimited: CSS offers an intelligent interface (read/write) to all common file formats (Lotus, Symphony, dBase, dBase III+, DIF, SYLK, ...) and special utilities to easily access data from incompatible programs; graphics can be saved in files compatible with desktop publishing programs (Aldus, Ventura). ■ CSS data files can be as large as your operating system (DOS) allows; OS/2 version coming soon. ■ CSS precision exceeds the standards of all common precision benchmarks. ■ *Technical note: The CSS user interface and all I/O were written in Assembler and bypass DOS; graphics and data management were written in Assembler and C; the computational algorithms were written in Assembler and optimized Fortran.* ■ \$495 (plus \$5 sh/h); 14-day money back guarantee.

Circle 219 on Reader Service Card



StatSoft

2325 East 13th Street ■ Tulsa, OK 74104 ■ (918) 583-4149

Fax: (918) 583-4376

Overseas Offices: StatSoft of Europe (Hamburg, FRG), ph: 040/4200347, StatSoft UK (London, UK), ph: 0438/310056 or 316561, StatSoft Pacific (Melbourne, Australia), ph: 613-663-6580
Available From: Egghead Discount Software, Corporate Software and other Distributors Worldwide

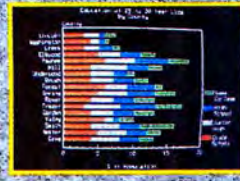
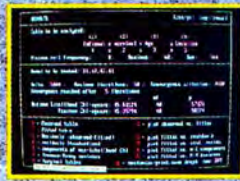
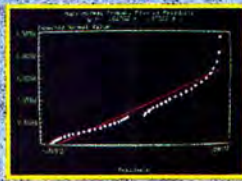
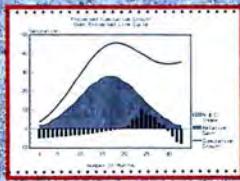
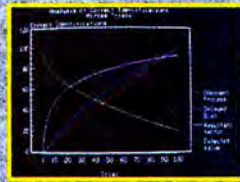
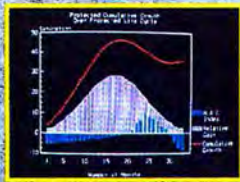
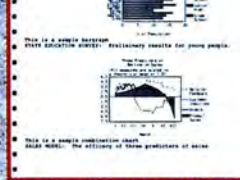
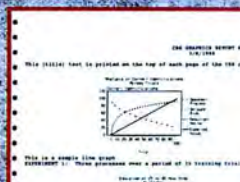
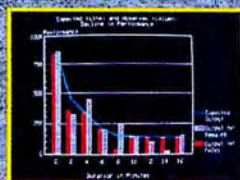
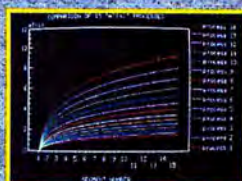
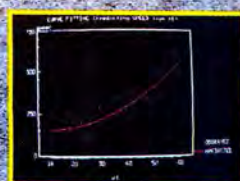
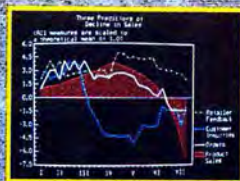



Diamond Scan 14
Auto-Tracking
800 x 600 pixels (digital, analog, monochrome)
330 x 500 pixels (composite NTSC)

Diamond Scan 20A
Auto-Tracking
800 x 600 pixels (digital, analog, monochrome)
1024 x 800 pixels (maximum)

Diamond Scan 16L
Auto-Tracking
1024 x 768 pixels (typical)
1280 x 1024 pixels (maximum)

Diamond Scan 20L
Auto-Tracking
Up to 1280 x 1024 pixels

Actual unretouched screen images
Monitors shown with optional bases

A Clear View To Monitor Quality

CHAOS MANOR

memory, so that I can switch from one to another; it speeds things up something wonderful.

DESQview on a PC-compatible is slow and might or might not be worthwhile, depending on your applications. On an 80286 machine, it's a rival to Microsoft Windows: it's easier to install, harder to learn, and considerably better with the general run of programs, although not as good as Windows running programs designed for Windows. DESQview is pretty good, a lot better than running an 80286 machine bare, and a way to make use of expanded memory; but it's not wonderful, either.

It's on an 80386 (and presumably the new 80386SX, which I haven't tried yet) that DESQview really speeds thing up.

DESQview 386 is really just an upgraded DESQview 2.2 plus a new release of Quarterdeck's QEMM-386 memory manager. (There's a 286 memory manager that speeds up DESQview for 80286 machines, but it's not the same.) I've been using a beta-test copy of this 80386-only package for a couple of months. I picked up the shipping copy at COMDEX, brought it home, installed it as an

update—if DESQview detects that there's an older version of itself on your hard disk, it doesn't change your configuration, macro, and information files—and began running. Incidentally, I like DESQview's installation a lot. There are all too many programs that don't pay any attention to whether you've already installed an earlier version.

Lately, my normal DESQview setup on the big Cheetah 386 has been GrandView in window 1, Q&A Write installed with Microlytics' Word Finder in window 2, and SideKick and Procomm Plus loaded in window 3. Norton Commander, DOS services, and other stuff go in later windows if I need them. When I exit Procomm Plus, the window doesn't close, and SideKick sits there ready to be accessed when I want it. I ran that way with the beta-test DESQview 2.2 for weeks.

The shipping copy crashed that system within 10 minutes. Worse: it crashed it in the worst possible way, by locking out the keyboard in Q&A Write while I was doing this column. Now, by "locking out" I mean locking *out*: nothing, including Ctrl-Alt-Del, worked. It was as

if the keyboard had been disconnected from the machine—so much so that I actually got down on the floor to check the cable connections. There was nothing for it but to hit the hardware reset button, thus losing all the text I had just entered.

Fortunately, my early training on microcomputers has stuck: I save text early and often, generally at the end of each paragraph. It's as much a nervous habit as anything else, but what with a fast 80386 machine and the Priam 330-megabyte hard disk drive, it doesn't take much time.

Anyway, I didn't lose much the first time DESQview locked up, and I was on my guard after that, which was just as well, because it did it three more times, at which point I decided that enough was enough. Before I installed the newest version of DESQview 2.2, I had, of course, saved the old copy off to the Maximum Storage APX-3200 WORM (write once, read many) drive; I figured it was time to restore it.

WORMs in Paradise

I had some minor glitches with that; I used every beta-test version of Maximum

Only one supplier of color monitors offers the widest selection of features and operating flexibilities in the market today.

That company is Mitsubishi Electronics.

Mitsubishi® delivers the reliability and performance that can meet your color information display requirements today as well as tomorrow. Larger screen sizes, truer colors, and optimum resolutions make your work easier—and far more productive.

Whether your requirements call for fixed-frequency graphics standards, like EGA and VGA, or multiple-frequency performance, Mitsubishi has the color monitor

with the resolution and size to fit your specific needs. This includes the Diamond Scan Series of 14", 16" and 20" auto-tracking monitors, some with microprocessor-enhanced programmable display settings. All at very competitive prices.

To get a clear view of monitor quality and value, look to Mitsubishi.

For product information or nearest authorized Mitsubishi Electronics sales representatives, please call 1-800-556-1234, ext. 54M. In California, call 1-800-441-2345, ext. 54M. Mitsubishi Electronics America, Inc., Computer Peripherals Division, 991 Knox Street, Torrance, CA 90502, (213) 217-5732.



XC1429C
VGA Compatible
640 x 480 pixels

XC1410C/XC1430C
EGA Compatible
640 x 350 pixels

Mitsubishi Model	Screen Size (inches)	Horizontal Scan Frequency (kHz)	Mask Pitch (mm)	Compatibility/Resolution							
				VGA					Apple Mac II	1024 x 768 (48 kHz)	1024 x 1024 (64 kHz)
				NTSC	CGA	EGA	Std.	Ext.			
Diamond Scan 14 (AUM1381A)	14/13V	15.7 - 36 auto-tracking	0.31	•	•	•	•	•	•		
Diamond Scan 16L* (HL6605TK)	16/15V	30 - 64 auto-tracking	0.31				•	•	•	•	•
Diamond Scan 20A (HA3905ADK)	20/19V	15.7 - 36 auto-tracking	0.31		•	•	•	•	•		
Diamond Scan 20L* (HL6905TK)	20/19V	30 - 64 auto-tracking	0.31				•	•	•	•	•
XC1429C	14/13V	31.5	0.28				•				
XC1410C	14/13V	22 or 15.75	0.40		•	•					
XC1430C	14/13V	22 or 15.75	0.31		•	•					

*Microprocessor-enhanced programmable display settings



© 1988 Mitsubishi Electronics America, Inc.
Mitsubishi is a registered trademark of Mitsubishi Electric Corp., Tokyo.

Screen images produced with permission from the following companies (trademarked software package name follows company name): Autodesk, Inc. (AutoShade); ComputerVision Corporation (Personal Designer); Computer Friends, Inc. (Modern Art); SuperMac Software (PixelPaint); ThreeDGraphics, Inc. (Perspective); Microsoft Corporation (Excel Version 2.0).

And Value.

CHAOS MANOR

Storage's software, and apparently I have version clashes now. It's nothing I'm worried about, since I was in fact able to recover all my files; but that took longer than I liked.

The principal symptom was that DIR showed me several files with the same name (but with different dates). This shouldn't be. A WORM drive does preserve everything you put on it—if you save several files with the same name, it creates a new one each time—but DIR isn't supposed to be able to find any but the latest copies. Anyway, Norton Commander also saw multiple copies, but since it lets you select (with a scroll bar) precisely which file you want to copy, I didn't have any great difficulties extracting the one I wanted.

A discussion with Theresa Beyers, Maximum Storage's technical wizard, generated the version-clash hypothesis. I'll try a new storage cartridge and the latest software; if that doesn't do it, they'll look at the drive hardware. Fortunately, I have a second drive (which will eventually go to the Lowell Observatory), so this is no problem.

Since I have recovered all my files,

I'm annoyed, not panicked; I still like WORM drives a lot better than I like tape backup. Even with the problems, I got the work done about as fast as tape or Fastback Plus would have done it.

Back to DESQview

Anyway, I got the old version of DESQview restored but left the new QEMM in place. That worked fine, so the night wasn't wasted. Next morning I called Gary Saxer at Quarterdeck.

After a long discussion, we concluded that the problem was an open Procomm Plus window containing SideKick.

SideKick was one of the earliest of the terminate-and-stay-resident (TSR) programs. It did things in a particularly sloppy way, and for reasons I don't quite understand, Borland never cleaned up SideKick's act. Both GrandView and Q&A Write know about DESQview. Word Finder doesn't, but it's a late model and a fairly well behaved TSR.

"SideKick, though," Gary said, "tries hard to intercept everything it can, and by definition a communications program runs in background. Meanwhile, we've been working real hard to make DESQ-

view work with multiple TSRs. I think SideKick is running in background and sometimes it sees what it thinks is its hot key."

"But I need SideKick—"

"You can open it in its own window. We know how to handle it there. But I think having SideKick in a communications window without the communications program may give it a chance to do mischief."

Could be, thought I. The DESQview documents are complete, if very hard to find anything in. (No index. I hate that. But that's all right: I think my son Alex and I will do a book on DESQview. That will have an index.) Eventually, I figured out how to work this.

I invoke SideKick, then Procomm Plus, in a batch file. I want SideKick because it has neat features in its notebook. The F4 key will capture text off the screen into the notepad editor. You can edit that text, or write your own, then do Control-K-E, and SideKick will squirt out a marked block of text through the modem. I use the combination for BIX, and it's very handy.

continued

However, when I would quit Procomm Plus, that particular window stayed open, and I used it as the SideKick window. DESQview's manual tells me that if the last command in the batch file that loads SideKick, then Procomm Plus, is EXIT, the window will close when I shut down Procomm Plus. If I want SideKick when Procomm Plus isn't up, I have to put it in a separate window. This sometimes means that I have two copies of SideKick running, but that's no problem.

I've made the recommended changes: I put EXIT in the batch file to load Procomm Plus, then reinstalled the latest version of DESQview. I've also opened SideKick in a separate window.

It works fine. I've been pounding away on this column for a few hours, and no glitches whatever.

The Quarterdeck people are working to see if they can't fix the problem from inside; meanwhile, DESQview works fine, but you shouldn't leave windows

with SideKick running in background even if you have enough memory. I can live with that limitation.

The diagnosis is confirmed. As a test, I opened the SideKick/Procomm Plus window and exited without closing the window; within 5 minutes, I had managed to hang up the Q&A Write window. After I reset, I put the EXIT command back in the Procomm Plus batch file, and the problem hasn't surfaced again.

At COMDEX I saw a great number of signs touting OS/2; every booth that had an OS/2 application running got a special sign from IBM. The reality, though, was that there were darned few real OS/2 applications on display, and none of them were very impressive. It's possible that OS/2 with Presentation Manager will be the wave of the future. Certainly it could be, given that IBM puts all that formidable marketing talent behind it. On the other hand, IBM has been wrong before. Remember TopView?

I still find DESQview with an 80386 the proper way to operate. Even if you have only an 80286, DESQview is a better bet than OS/2 just now. I don't expect that to change for at least a year. Probably longer.

Norton Again

I always enjoy seeing Peter Norton, but although he lives no more than 10 miles from Chaos Manor, we get to talk only at computer shows. Like me, he's got so much to do that he seldom has time for social activities. The result is that we mostly get together on business. COMDEX was no exception. Norton had a suite in the Sahara, where he was showing new products, and, alas, my visit there was the only time we got to talk. At least we made a tentative date for dinner Real Soon Now.

His most important new product is the Norton Utilities 4.5 (available in standard and advanced packages), which turns out to be a bigger improvement over version 4.0 than the version numbers indicate. The advanced package includes Norton Disk Doctor, a program they wrote to diagnose and fix logical disk problems. Unlike Steve Gibson's SpinRite, NDD doesn't correct format errors; but it will unscramble a munged file allocation table, fix a boot record, repair the media byte, and take care of a number of other DOS disk problems.

I'm already on record as saying that everyone needs the Norton Utilities. Just last night I managed to erase a file I wanted to keep, and Norton Utilities got it back for me with no muss or fuss; and I

continued

WHY DESIGN YOUR PRODUCT AROUND A COMPUTER?

Design the computer in.



Little Board™/286

Built-in vs. built-around. External systems mean boxes, boards, backplanes, cables, and reliability problems. Ampro's Little Boards give you a complete system on a single board you can build right into your product.

Small size. Big power. Eliminate the bulk and constraints of multi-board, backplane-based systems. Embed a Little Board that requires just 2/3rds the power and volume of a 5 1/4" floppy drive. But with the full power of a PC or AT®.

Fully compatible. Little Board/286 and Little Board/PC are functionally identical to multi-board PCs and ATs. They run PC-DOS™ 2.0 to 3.X. They run DOS languages, compilers and applications. You'll be standing on a proven foundation of hardware and software.

Ampro's Single Board Systems. It's all there. Up to a Megabyte of RAM. RS-232C and Parallel ports. AT/PC-compatible controllers and bus expansion. EGA/CGA/MDA and Hercules™.



Little Board/PC

compatible video options. Even optional solid-state disk. Plus SCSI support for hard disk, tape, optical drives, bubble drives... you name it. And, low power consumption (+5VDC, less than 8W) and a wide operating temperature range (0 to 60°C). Perfect for standalone operation and harsh environments. Anywhere that reliability is a critical consideration. Available worldwide. For information and the name of your nearest U.S. or international Ampro representative, call us at the number below. Or write for Little Board Product information.

Now includes DR-DOS™

408-734-2800

Fax: 408-734-2939 TLX: 4940302

AMPRO

COMPUTERS, INCORPORATED

1130 Mountain View/Alviso Road
Sunnyvale, CA 94089

Reps: Australia—61 3 720-3298; Austria—43-222/45 01; Canada—(604) 438-0028; Denmark—45 3 66 20 20; Finland—358 0 585-322; France—331 4502-1800; Germany, West—49 89 611-6151; Israel—972 3 49-16-95; Italy—39 6 811-9406; Japan—81 3 257-2630; Netherlands—010-411 85 20; Spain—M34 3 204-2099; Sweden—46 8 55-00-66; Switzerland—41 1 740-41-05; United Kingdom—44 2 964-35511; USA—contact AMPRO

Trademarks: IBM, AT—IBM Corp., Hercules—Hercules Computer Technology, Inc., Little Board—Ampro Computers, Inc., DR-DOS—Digital Research, Inc.

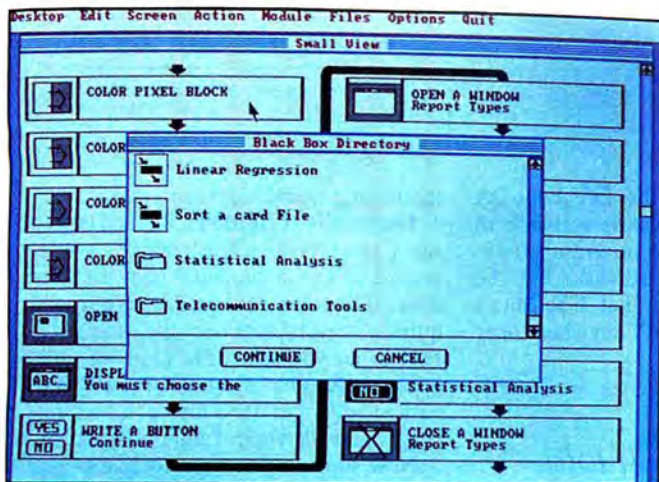

OOPS. Using sophisticated Object-Oriented Programming, Matrix Layout gives you the power to build complete applications faster than you thought possible. And that's just the beginning.

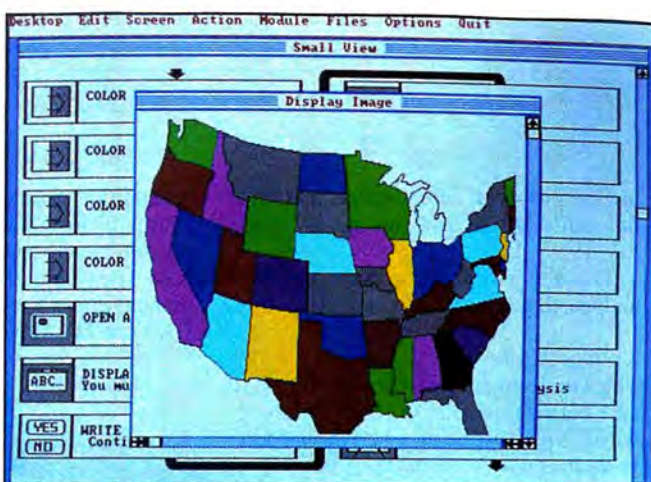

CASE. Layout's Computer Aided Software Engineering functions let you design programs using an intuitive flowchart model. Then, Layout can automatically turn your flowchart into source code or even an .EXE file.

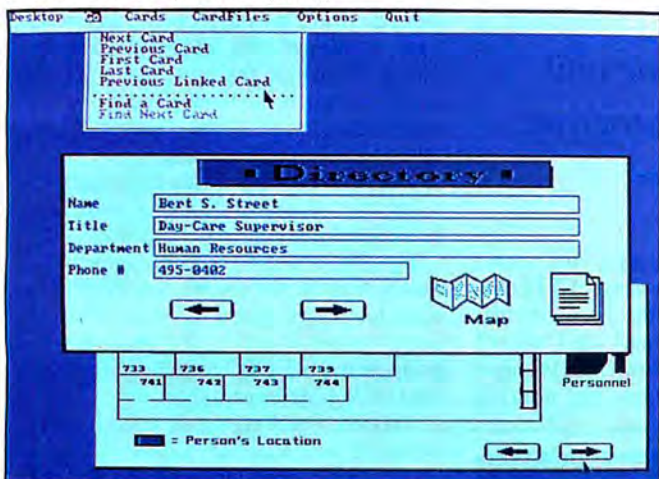

Hypertext. Layout puts all the features of Hypercard® on your PC and in your programs. Use Layout's graphical user interface to create documents with action links to related documents in any file. Or to create hyperlink applications.



Plus, your favorite programming language(s). Using Layout's tools, you can cut your coding time up to 70 percent, and still produce ready-to-run programs in your choice of languages.

A Great Programming Tool Should Contain All Of The Above.

Presenting Matrix Layout, the first full software development system for the PC to promise you all the above. And deliver.

Sit down to Layout's intuitive user interface and in minutes you'll be using advanced OOPS (Object-Oriented Programming System) and CASE technology to build your program. Simply draw a flowchart indicating the windows, buttons, menus, text, and graphics you want.

A Cut Above Other Tools.

Layout also provides flowchart elements for Hypertext data base capabilities, math functions, variable management, conditional branching and looping. And, its open architecture allows you to build your own Black Box elements — to create exactly the program you want.

When your flowchart is ready, Layout uses

artificial intelligence technology to automatically turn it into code — Turbo Pascal, Turbo C, Microsoft C, QuickBasic or Lattice C. Or create a ready-to-run .EXE file right from within Layout.

It's so efficient, your programs will run incredibly fast, even on a standard 256K PC. Plus, they'll include Layout's automatic mouse support and device independence.

All The Above And More.

- Matrix Helpmaker helps you create context-sensitive help and complete on-line documentation for your programs.
- Matrix Paint offers a full set of graphics

tools, scanner support, and clip-art files to make your programs look professional.

- Finally, Matrix Desktop gives you a simple, visual way to organize files and disks.

For A Lot Below.

Layout delivers all the above for just \$149.95 — a lot below what you'd expect. Especially when you throw in free customer support, no copy protection, and a 30-day, money-back guarantee.

Video Tape Offer. Still not convinced? Call for a copy of our Matrix Layout VHS demonstration video at 1-800-533-5644 (just \$9.95 for shipping and handling, credited against your purchase). In Massachusetts, call (617) 567-0037.

Any way you look at it, Matrix Layout is the ultimate PC programmer's tool. And that's the bottom line.

MATRIX
LAYOUT

Matrix Software Technology Corporation • One Massachusetts Technology Center • Harborside Drive • Boston, MA 02128 • (617) 567-0037

Matrix Software/UK • Plymouth, England • 0752-796-363 • Matrix Software/Belgium • Geldenaaksebaan 476 • 3030 Leuven • 016202064
The following are registered and unregistered trademarks of the companies listed: Matrix Layout, Matrix Paint, Matrix Helpmaker, Matrix Desktop, Matrix Software Technology Corporation; Macintosh, Hypercard, Apple Computer, Inc.

use the disk sort, screen color, and other programs in the package nearly every day.

The new edition is a major upgrade, and worth getting. Recommended.

ConvertUnits

The whole appeal of the Macintosh is ease of learning and use. That's probably why it's so frustrating when things don't go well.

At COMDEX I was handed a copy of a program called ConvertUnits from GTA. This is said to be the most complete and accurate unit-conversion program for the Mac. It can be installed as a HyperCard stack or as a desk accessory (DA).

I've long had such a program for my IBM PC. It can go in as a TSR or be set up in its own DESQview window. I don't use it a lot, but when I do need it, I need it bad. I figured I ought to have something like that on the Mac II, and setting it up as a DA seemed like the right way to go about it.

The problem is that I don't do that very often, so I had to rely on the ConvertUnits manual. That, alas, is incomplete. To make ConvertUnits work, you must,

in addition to using the DA Font/DA Mover to install the access software in the DA menu, copy the program's database files onto the hard disk; but the manual doesn't tell you that. The Mac's DA Font/DA Mover isn't anywhere near

All told,
*ConvertUnits is a
scientifically complete
and accurate unit-
conversion program.*

as intuitive as Apple thinks, so I wasn't sure what I was doing wrong. All I knew was that I had followed the directions that were given in the manual, and when I was done, I could pull down the DA menu and select ConvertUnits, but nothing

interesting would happen.

Eventually, I figured it out and copied the ConvertUnits file (which is misnamed in the documents) onto the boot disk. Then I discovered another odd quirk. ConvertUnits uses the Mac interface to let you select the kinds of units you're interested in and what you'll convert to and from. You then enter a number from the keyboard and press Return.

Now suppose you want to change one of the units but don't want to change the value (unity, for example, if you're interested only in how many ticks of a cesium atom there are in a day, a week, a galactic year, a tropical eon, etc.); you use the mouse to change the unit, but now you have to let go of the mouse and press Return, because there's no "activate" button in the ConvertUnits display.

There are other awkwardnesses in using the program. None of them are fatal. Just annoying.

Finally, you can't add new units to the database table. Of course, you might not want to: the program has a remarkably complete set of units, just about everything in the big *CRC Handbook* (including furlongs and fortnights).

All told, ConvertUnits is scientifically complete and accurate. I haven't seen a better unit-conversion program for the Mac, but I do wish they'd do an overhaul on the user interface.

Peabody

I never thought I'd want an on-line DOS help program. After all, I know the common commands, and if there's something I can't remember, such as the different switches (e.g., /s or /a) for XCOPY, I can always use Chris DeVoney's *Using PC-DOS* to look it up. So I believed until the other day, when I was experimenting with some stuff dangerous enough that I wanted to make frequent backups to my WORM drive and found that I was looking up the same things over and over again. Then I remembered Peabody.

I suppose the world is divided into two kinds of people, those who were Rocky and Bullwinkle fans, and those who weren't. Me, I never missed an episode, so I remember Mr. Peabody, the rather snobbish dog who had adopted a boy named Sherman.

Copia International has licensed the name and image of Mr. Peabody for their series of on-line help programs. The programs are pretty big to be memory-resident in a PC, but they know how to use extended memory, so if you have an AT or 80386 machine, you can get away with using as little as 25K bytes of main

- 4 megabytes of memory.
- Extended and expanded memory. LIM 4.0.
- Works with all of your programs.
- Run DOS or OS/2 effortlessly.
- Fast and simple switchless installation.
- Auto-configuration for all operating systems.
- Works in all Micro Channel™ computers.
- Expanded memory 10 times faster than Intel.
- Risk free guarantee. Two year warranty.
- IBM approved ID. \$349 0K.

Call today 1-800-234-4232 or 617-273-1818



Capital Equipment Corp.
Burlington, MA. 01803

PS/2 and Micro Channel are trademarks of IBM

Special Limited Time Offer.
Save \$100 on every OS/RAM4
with 2 Mbytes or more of memory.



Order today. Call 1-800-234-4232

**I want the best PS/2[®] memory, with
the best price and best performance.**

Name _____
Company _____
Address _____
City _____ State _____ Zip _____
Telephone _____

I need more information on your

OS/RAM4

Warranty

Fast shipment guarantee

OS/RAM8

Installation

Risk free guarantee

Price

Quantity discounts

Other _____

Performance

Reseller agreements

Return this card or call 1-800-234-4232.

Special Limited Time Offer.
Save \$100 on every OS/RAM8
with 2 Mbytes or more of memory.



Order today. Call 1-800-234-4232

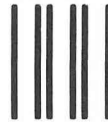

No Postage
Necessary if
Mailed in the
United States

BUSINESS REPLY MAIL

FIRST CLASS PERMIT NO. 381 BURLINGTON, MA

Postage will be paid by addressee:



CAPITAL EQUIPMENT CORP.

99 S. Bedford St. #107
Burlington, MA 01803

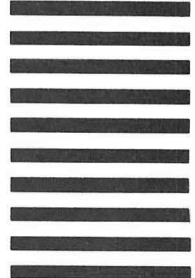

RAM. I set the Peabody MS-DOS guide up in its own DESQview window and found it pretty useful, so I installed it in the DESQview menu system. I don't normally need it, but it's convenient to have it available when I want it.

The really valuable guides are those for various languages. There's a Peabody guide to C, Turbo Pascal (3.0 and 4.0; 5.0 is in preparation), and Microsoft assembly language. That last one also has a whole bunch of stuff about the iAPX86 family of chips: registers, instruction timings, and the like.

I'm not likely to need the C and assembly language guides, but the Turbo Pascal guide intrigues me. While I don't do a lot of programming on the road, I might do more if I had portable reference documents, which is what Peabody is.

They've done a pretty good job with the interface design. It reminds me a lot of HyperCard, what with the ability to do recursive lookups. Peabody pops up with hot key combinations. One will bring up the table of contents, so that you can page through until you find what you want. The information is pretty complete, too. Moreover, Peabody lets you add to its database. You can put in new stuff or do customized reorganization of what is already there.

Peabody's direct competitor is Norton, whose Guides work a lot like Peabody but have a different user interface (not necessarily better or worse, just different). Like all Norton software, these Guides are darned good; but unlike Peabody, you can't extend them.

Peabody has other exclusive features, like the "sticky window": you can designate one of the Peabody windows and have it remain on-screen at all times. There's also a way to couple Peabody with a particular program, like your programming editor. (I note that Copia uses BRIEF in their examples. Good choice.) All in all, I prefer Peabody to the Norton Guides.

A program like Peabody is a bit like power steering: you don't know you want it until you've tried it. If I did C programming, I'd sure want Peabody C. I intend to get a lot of use out of the Turbo Pascal guide. Now I wish they'd do one for QuickBASIC.

You may like this one a lot more than you think you will. I know I did.

TianMa

COMDEX had a number of booths exhibiting products from Chinese companies, both from the People's Republic of China and the Republic of China (Taiwan). It doesn't take a lot of smarts to

predict that trade with China will grow steadily; and while a great many more Chinese learn English than Americans learn Chinese, it's also pretty clear that those who can communicate in Chinese will have an advantage. The problem is that even if you know the language, it's not easy to write a letter in Chinese.

Chinese writing consists of individual characters, or pictograms; each character represents a word or an idea. The characters are written in vertical columns and from right to left. You need to know several thousand characters to write the average newspaper article and even more to write a typical BYTE article in Chinese.

I once saw a Chinese typewriter. In order to have enough characters, it had several interchangeable sets of keys. Using it was extremely difficult. Still, I was told, it was a lot faster than doing it by hand.

TianMa will apparently solve that problem.

I say "apparently" because I don't know Chinese, and thus I can't legitimately make a stronger pronouncement; but, in fact, I have no doubts that this pro-

gram does what it says it does. The TianMa exhibition was set up in the corridor connecting the two halves of the exhibits in the Bally Grand, and every time I passed it, the area was filled with admiring Asians, many of whom couldn't speak English. They were impressed: I must have seen a dozen copies sold on the spot.

TianMa consists of a ROM board and some software. When it's installed on a PC or an AT, you can type Chinese text using a phonetic entry system—the brochure says you can choose between the pinyin and bopomofo methods, and the program set includes a tutorial on each—and see your text on-screen in Chinese characters. The TianMa ROMs have both classical and simplified fonts and display the xinhua zidian character set. The program supports high-resolution Hercules, CGA, and EGA boards, and it doesn't require any modification to the computer (beyond installing the board).

TianMa software has WordStar-like editing capabilities, including global search and replace and block operations. When you're satisfied with your work,

continued

PS/2[®] MEMORY

Introducing **OS/RAM8™**.

- ✓ 8 Mbytes of memory + 2 serial ports.
- ✓ Extended and expanded memory. LIM 4.0.
- ✓ Works with all of your programs.
- ✓ Run DOS or OS/2 effortlessly.
- ✓ Fast and simple switchless installation.
- ✓ Auto-configuration for all operating systems.
- ✓ Works in all Micro Channel™ computers.
- ✓ Expanded memory 10 times faster than Intel.
- ✓ Risk free guarantee. Two year warranty.
- ✓ IBM approved ID. \$449 0K.

Call today 1-800-234-4232 or 617-273-1818

cec Capital Equipment Corp.
Burlington, MA. 01803

PS/2 and Micro Channel are trademarks of IBM

you can print your Chinese text on a LaserJet II or LaserJet Plus. The print quality on a LaserJet is excellent, certainly as legible as, say, the Chinese translations of my books. (Of course, I can't read those books, but I can compare typeface legibility.) The TianMa literature says the program will support DeskJet, the Epson LQ series, and several other printers, but I haven't seen samples of any output but LaserJet's.

The program was demonstrated by its author, Peter Leimbiger. From what I could tell, it's amazingly fast, a lot faster than any other way I know of to get Chinese text into print. Again, this is one of those programs that not everyone will want, but if you need it, you need it bad.

Data Recovery

I remember when my mad friend, the late Dan MacLean, confidently predicted that we'd soon have hard disk drives for microcomputers.

"They'll be expensive, I bet," said I.

"Yeah, but worth it. Think of it, 5 megabytes of storage, and one day they'll sell those for less than a thousand dollars."

Of course, that was back in the days when all we had was 160K-byte single-sided 8-inch floppy disks; and mostly it proves that even the best of us is generally too conservative in predicting the future of the microcomputer revolution. I'm writing this on a machine that has a Priam 330-megabyte drive, and at COM-DEX Priam was showing 765-megabyte drives that operate at a 14-millisecond average access time. I didn't see them, but I'm told that Micropolis was showing gigabyte drives able to fit into an AT chassis. Amazing. We've sure come a long way.

The near universal use of hard disk drives has given rise to another profession: data recovery. Alex and his partner Barry Workman have built a thriving business around peeling data off lunched hard disk drives. Just the other day, Alex brought over a Mac II with a bad hard disk drive, and he did some kind of kludge that involved connecting that machine to my Mac II with its Priam Mac-Disk (300-plus megabytes). Whatever he did worked fine; he got all his client's data back. (If you need help in recovering data, you might want to contact

Workman and Associates at 1925 East Mountain St., Pasadena, CA 91104, (818) 791-7979.)

While Alex was here, I had him look at Paul Mace's new book, *The Paul Mace Guide to Data Recovery* (Simon and Schuster, 1988), and his opinion confirms mine: essential reading. Mace tells you, simply and quite readably, what causes data loss and how to prevent it. Mace, you'll recall, was the first person to figure out that you could recover data from a hard disk that had accidentally been reformatted. Since then, he's become an expert on data recovery and loss prevention.

If you don't read another computer book this year, read this one. It could save you a lot of grief.

Cambridge Z88

Sir Clive Sinclair's latest computer product is the most portable computer I've ever seen: the Z88 (properly pronounced in the British manner "Zed-88"). This is a thin (less than an inch) and lightweight (less than 2 pounds) compact portable that comes with a number of programs in

continued

FIVE GOOD REASONS TO BUY A MOUSE-TRAK.™

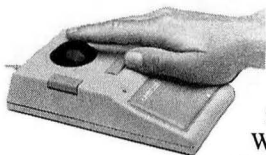

Count them. With MOUSE-TRAK, five fingers do all the work. Because it uses trackball technology, input and precision control is at your fingertips, not your elbow.

With CAD, Desktop Publishing or Spreadsheet

applications, MOUSE-TRAK is easier, faster, more relaxed and a lot more comfortable to use than ordinary input devices.

MOUSE-TRAK OFFERS YOU OPTIONS

2 or 3 buttons — speed control — Multiple Interfacing

MOUSE-TRAK is stationary. Only the highly efficient trackball moves, eliminating tiresome arm and wrist movement. You can operate MOUSE-TRAK in your hand, even sit back with it on your knee. It plugs into your computer and needs no additional power supply.

User definable input keys are in easier-to-use locations. The uniquely patented shape has

been developed through rigorous ergonomic studies of hand sizes and finger geometry. Made in the U.S.,
MOUSE-TRAK

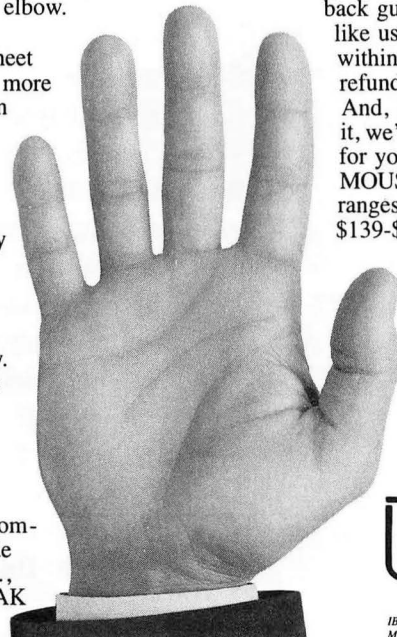
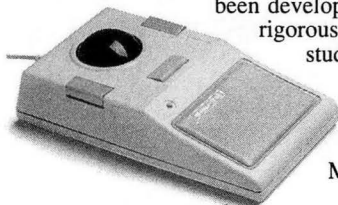

is already in use by the military in planes, subs and tanks. Engineers at IBM™, Texas Instruments™ and Motorola™ are also using MOUSE-TRAKS.

MOUSE-TRAK carries a money back guarantee. If you don't like using MOUSE-TRAK within 30 days, we'll refund your money. And, if you do like it, we'll give you \$10 for your old mouse. MOUSE-TRAK ranges in price from \$139-\$189.

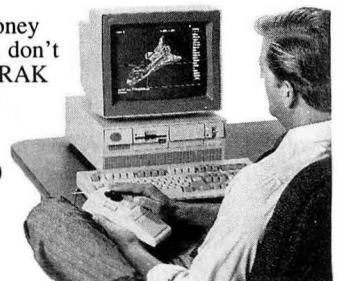

Call us toll-free for the complete story on MOUSE-TRAK and the name of a dealer near you. Our new brochure is available upon request.

MOUSE-TRAK combines mouse interface technology with the convenience and precision of a tracking ball. There's no wasted motion or time.

1-800-533-4822
(in Texas 214-494-3073)



3121 Benton Street, Garland, Texas 75042 USA. Telefax 214-494-4159

IBM, Texas Instruments and Motorola are registered trademarks of their respective companies. MOUSE-TRAK is a registered trademark of ITAC Systems, Inc.

STATGRAPHICS®

NEW!
LARGER DATA SETS

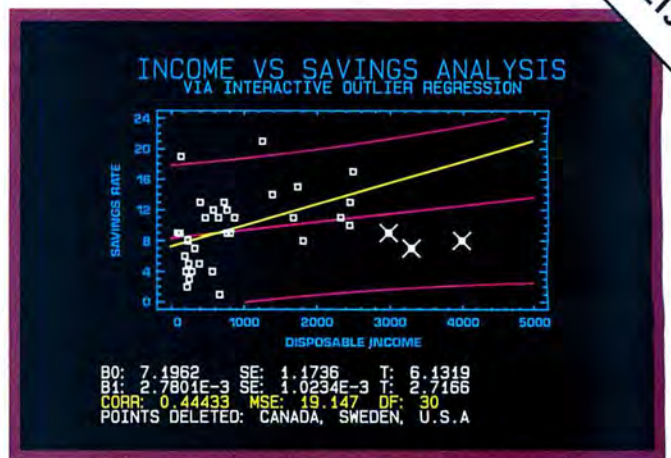
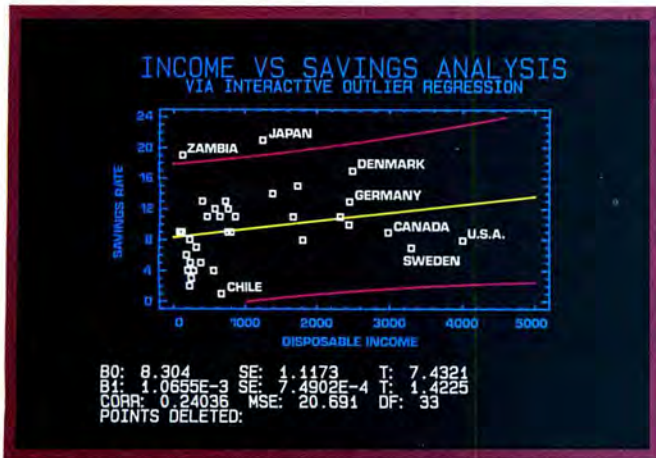

Select the points you want to remove from your regression model...

... Then press F6 to refit the model and recalculate the statistics.

Because "Statistical Graphics" Is Better Than Just Statistics and Graphics

Most of today's PC statistical packages give you all the statistics you'll ever need. Some even give you a few graphics. But only STATGRAPHICS from STSC gives you integrated statistical graphics in an environment you control.

Unique "What If" Interactivity

STATGRAPHICS lets you explore data relationships fully, producing higher quality, more timely solutions. Define your data and assumptions, run the procedure and review the results, modify data and assumptions repeatedly and take another look—and another. All without leaving the procedure or making permanent changes to your data.

Integrated Statistical Graphics

Coupled with STATGRAPHICS' interactive environment are over 50 types of graphs—traditional pie and bar charts, histograms, 3-D line and surface plots, quality control charts, and more. All are integrated with the procedures so that they can be displayed instantly and modified repeatedly.

Query data points, do on-screen forecasting and model fitting, overlay graphs, or zoom-in on any area for a closer look. With flexibility like that, you can spot and investigate visual trends in your data—trends you may have missed if you looked only at the numbers.

Over 250 Statistical Procedures

- Direct Lotus® and dBASE® interfaces
- ANOVA and regression analysis
- Experimental design
- Quality control procedures
- Multivariate techniques
- Nonparametric methods
- Exploratory data analysis
- Forecasting, time series analysis, and more.

STATGRAPHICS—

The Best Way to Do Statistics!

Put the power of STATGRAPHICS to work for you today—all for only \$895*. For our free convincer kit or the name of a dealer near you, call **(800) 592-0050 ext. 400**

In Maryland, (301) 984-5123;
Internationally, (301) 984-5412.
Telex 898085 STSC ROVE

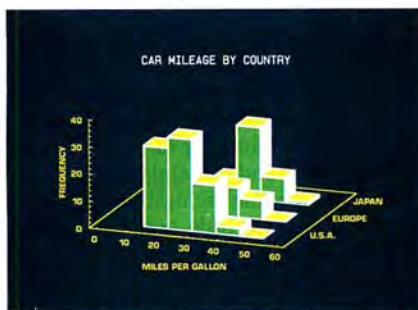
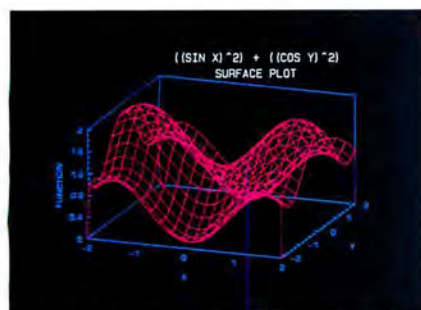

A wide variety of graphs supported on over 100 displays, printers and plotters, including the new IBM PS/2™ Series.

STSC STSC, Inc.
2115 East Jefferson Street
Rockville, Maryland 20852

*Suggested retail price in U.S. and Canada. International prices vary. Available through dealers and distributors worldwide. STATGRAPHICS, Lotus, and dBASE are registered trademarks of Statistical Graphics Corporation, Lotus Development Corporation, and Ashton-Tate, respectively.

ROM. These programs include an integrated spreadsheet and word processor; a "diary," which we would call an appointment calendar; an alarm clock; and a printer driver. Optional software includes a database manager, a communications package, and stuff like that, some available now, the rest coming "pretty soon."

The literature says it has 8 lines of 80 characters on the supertwist screen. While this is technically true, two of those lines are taken up by the ROM-based programs and can't be dispensed with; that leaves only 6 lines. If you go beyond 72 characters on a line, there's horizontal scrolling. Since horizontal scrolling when you're trying to write is about as useful as a chocolate covering for your wristwatch, in effect you have 6 lines of 72 characters.

The screen isn't particularly easy to see. Naturally, it's not backlit, and the letters are small. Still, you *can* see it. I used the Z88 to take notes at a couple of meetings, including the planning session for the next West Coast Computer Faire, and that turned out to be fairly easy. Of course, I was sitting at a table in a well-lit room. Now I have the Z88 on the mouse table next to me as I write this; my room is certainly well lit; but I'm having trouble seeing the Z88's screen. However, if I put it dead in front of me, there's no problem.

The Z88's keyboard is well laid out. It's covered with a rubber film to protect the system from anything wet; presumably, you can spill your Jolt Cola on this without harm. The unit has a substantial and solid feel; I like it. The keys are *very* sensitive, much more so than I'm used to, but again I can adjust. I didn't have a lot of problems using it for notes at COMDEX, and everyone around me appreciated how quiet the Z88 is compared to the Tandy Model 100 or NEC PC-8201. There's no key click at all.

The manual says the system can be attached to a disk drive, but there's no reference to any such thing in the sales literature. I make no doubt that if it becomes at all popular, Traveling Software will come up with a version of LapDOS to connect the Z88 to the small battery-powered Brother floppy disk drive.

Meanwhile, the system relies on little memory pack cartridges. These are quite small, smaller than a packet of cigarettes (and considerably thinner). They come in 32K- to 512K-byte sizes. The 32K-byte cartridge costs \$45; the 512K-byte cartridge, which is what I suppose you'd actually need (since this is your only real storage device), is \$440, no small sum.

Like everyone else, Sir Clive was caught in the memory price crunch; when this system was first designed, memory was nearly free, and the little memory cartridges were intended to be a lot cheaper.

There's also a cartridge for transferring data from the Z88 to a PC-compatible (and another for the Mac). The PC Link (composed of a cartridge, a disk for the PC, and cable) costs \$75. The Mac version is unaccountably \$129; I'd presume that's merely a reflection of the fact that everything associated with the Macintosh costs more.

If you
write any BASIC
programs for the
Cambridge Z88 or have
really valuable data,
you can save to
an EPROM cartridge.

If you write any programs for the Z88 (it has built-in BASIC) or have really valuable data, you can save to an EPROM cartridge. These cost \$45 for 32K bytes and \$110 for the 128K-byte variety. EPROM is the only way you can permanently store things for the Z88; if I were traveling with this machine, I'd want the ability to EPROM anything important I wrote. I'll tell you why in a minute.

The point is that if you want a practical Z88, you'll pay for it: \$599 for the machine itself; at least \$110 for a 128K-byte RAM cartridge, and more likely \$440 for 512K bytes; another \$110 for an EPROM cartridge (in fact, I'd want to have two or three for a long trip, although I might not use any of them); and at least \$75 for a PC Link package. This adds up to a minimum of \$894, and it wouldn't be hard to have considerably more than that in it. But that's not a *lot* of money for a good portable, and certainly the Z88 is convenient. It's the lightest-weight and just plain handiest little notebook computer I have seen.

That's hardware.

The major software of the Z88 is an integrated spreadsheet and word processor called Pipedream. In theory, this ought

to be a great idea: you can put a spreadsheet into any document you're writing.

In practice, it's disappointingly hard to use. As an example, if I start a paragraph with a tab (which I am in the habit of doing), the result is a *permanent* shift of the left margin. I thought perhaps that somewhere buried in the documents (over 200 pages) I'd find a way to cause all the lines except the first to go to the left side of the screen, but I tried all I could find from the index, and all I managed to do was make a monumental mess of what I was trying to write; I ended up with a second document about six characters wide over to the left of my first one. As far as I can tell, the only real remedy is never to use a tab when you're writing. That's quite a sacrifice.

There are other glitches. The upshot is that although the documents make it look as if you could get along with a Z88 as your only computer, I sure wouldn't want to if I had to use it a lot. The Pipedream text editor just can't forget that it's *really* a spreadsheet, and thus it only tolerates being used to write English text.

The Z88 should fare better as a second machine used as a notebook for students and journalists. In previous columns, I've complained about the weight of my Zenith SupersPort 286 laptop: I love it when I get it to my hotel room, and indeed I did a lot of writing I wouldn't have done at COMDEX if I'd had anything less powerful with me. On the other hand, I sure wasn't about to carry the SupersPort around with me to meetings, or even from my hotel room to the BYTE booth. It's just too darned heavy.

Incidentally, I have managed to take some of the sting out of the SupersPort: I got a Sky Valet garment bag, the kind that turns itself into a sort of luggage cart. The SupersPort sits nicely on the little pop-out plastic briefcase holders. It's really easy to get around airports with that combination, and it sure came in handy standing in the 45-minute taxi line at the Las Vegas airport.

Anyway, I was eager to get the Z88 as a second computer. It's light enough to fit in the bag with the SupersPort, then be carried around to meetings as a notebook; and I did that, using it to take a lot of COMDEX notes. I did have to be careful never to use a tab, but what the heck.

Unfortunately, all those notes have vanished.

The Z88 is supposed to save your stuff, even if you merely turn the machine off. The PC-8201 does that. So does the Model 100.

Alas, the Z88 doesn't really do that.

continued

"TOPSPEED EARNS A STANDING OVATION!"

— Kent Porter, Dr. Dobbs Journal



"...TopSpeed is surely one of the finest new products introduced to date in the PC arena...DDJ doesn't give unqualified raves very often, but there's no question about it in this case; JPI's TopSpeed Modula-2 is first-rate."

Kent Porter
Dr. Dobbs Journal

"JPI Modula-2 looks like another classic in the making. It generates code as good as or better than leading C compilers and the programming environment is a genuine pleasure to use."

Dick Pountain
BYTE Magazine
August '88, pg. 88IS-3

"I liked all of the hard-disk space that was recovered after I deleted my BORLAND, MICROSOFT, and LOGITECH compilers, because with TopSpeed Modula-2 all the rest are obsolete."

Robert D. Randall
Donnelley Marketing

In England and Europe contact:
Jensen & Partners UK Ltd., 63 Clerkenwell Road, London EC1M 5NP. Phone: (01)253-4333. Compiler Kit: £59.95, TechKit £34.95, VID £34.95, DOS 3-Pack £119.95

Handling charges: In UK please phone for VAT and P&P. In Europe, add £6 for up to 3 products, £2 for each add'l product.

The successor of Pascal: JPI TopSpeed™ Modula-2 produces better code than Microsoft C, Turbo C, Logitech Modula-2 and Turbo Pascal 4.0.

Debug with VID: The easy-to-use, source-level debugger. Single-step and trace through source in multiple modules. Examine and modify all variables in symbolic form, including arrays, records, enumerated types and pointers. Point and shoot breakpoints including "One-shot," "Sticky," "Delayed," and "Monitor." Watch both variables and Modula-2 expressions during execution. Automatic variable trace of all variables accessed, and assembler, registers and procedure call-stack trace windows. Package includes symbolic disassembler and execution profiler. 72-page manual.

The Compiler Kit includes: High-speed optimizing compiler (3,000-5,000 lines/min. on a PC AT 8MHz), integrated menu-driven environment with multi-window/multi-file editor, automatic make, fast smart linker. All Modula-2 sources to libraries included. BONUS: Complete high-speed window management module included with source. 258-page User's Manual and 190-page Language Tutorial.

The TechKit™ includes: Assembler source for start-up code and run-time library, JPI TopSpeed Assembler (30,000 lines/min.), TSR module, communications driver, PROM locator, dynamic overlays, and technical information. 72-page manual.

System Requirements: IBM PC or compatible, 384K available RAM, two floppy drives (hard disk recommended).

Circle 118 on Reader Service Card



TopSpeed's seamlessly integrated environment.



VID (Visual Interactive Debugger): power without complexity.

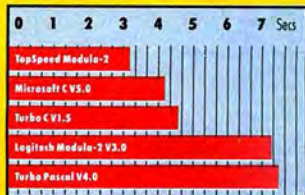

Sieve benchmark measured by the British Standards Institution (BSI)—25 iterations on an 8MHz AT.

Compiler Kit \$99.95
TechKit \$59.95
VID \$59.95

DOS 3-Pack \$199.95
(Compiler, TechKit & VID)

To Order:

In the US, call:
1-800-543-5202

In Canada, call:
1-800-543-8452

Or mail us your order with a check, money order, or VISA/MC information. 30-day unconditional money-back guarantee.

Shipping & handling charges:
In North America: add \$5, plus \$2 for each add'l product. CA residents please add applicable sales tax.
Overseas: add \$20, plus \$8 for each add'l product.



Jensen & Partners International

1101 San Antonio Rd.
Suite 301
Mountain View, CA 94043
Phone: (415)967-3200

TopSpeed and TechKit are trademarks of Jensen & Partners International. Other brand and product names are trademarks or registered trademarks of their respective holders.

THE PROGRAMMER'S SHOP

helps save time, money, and cut frustrations. Compare, evaluate, and find products.

NEW Catalog!

Our new, colorful, completely updated catalog lists over 700 of the most popular, cutting-edge programmer's tools, clearly organized into intuitive function categories. Completely indexed by product and manufacturer plus helpful notes on every item listed, common questions and answers. Yours FREE when you call.

Assemblers

	List	Ours
MS Macro Asm	150	105
Turbo Assembler/Debugger	150	115
Visible Computer 80286	100	89

C Language - Compilers

AZTEC C86 - Commercial	499	Call
High C-286 - by MetaWare	595	Call
Lattice C - V3.4	450	289
Microsoft C 5.1 - w/CodeView	450	299
Microsoft QuickC	99	69
Turbo C - by Borland	150	115
Watcom C6.5 - highly optimized	295	269

Dbase & Tools

CLEAR+ for dBASE	200	159
Clipper Summer '87	695	449
dBASE IV	795	529
dBASE Online	99	89
dBRIEF w/BRIEF	275	Call
dBUG - source debugger	195	179
Documentor	295	239
DBXL Interpreter	199	149
FoxBASE 4 - V2.1	395	259
FoxTool Box	295	279
Genfile - code generator	395	259
R&R Relational Report Writer	149	139
R&R Clipper & FoxBASE	55	45
Quicksilver Diamond	599	369
UI Programmer	295	249

New Discovery Logic Gem

by Sterling Castle. Logic-processing code/generator/expert system generator. Create logic tables; interactively test, translate to C, Pascal, Structured/Interpretive BASIC, dBASE, English source. \$179.

Debuggers

	List	Ours
Periscope II - breakout switch	175	139
Periscope III - 10 MHz version	1395	1129
Sourcer	100	89

Editors

BRIEF	195	Call
COMPEDITOR	175	165
Edix	195	159
Epsilon - like EMACS	195	159
KEDIT - like XEDIT, V.4	150	125
Personal Rexx	125	109
ME Macro Editor - Source	189	159
MKS VI	75	69
EDT + 4.0 - like VAX EDT on PC	295	269
SPF/PC - V2.0	245	189
Vedit Plus	185	135

Text Screen Addons

C Worthy w/forms with source	295	Call
Curses - by Aspen Scientific	495	Call
Greenleaf DataWindows	119	109
PowerScreens - by Blaise	295	209
Vitamin C - source, menus	129	99
Windows for Data	225	169
	295	265

Note: Mention this ad. Some prices are specials. Ask about COD and POs. Formats 3" laptop now available, plus 200 others. UPS surface shipping add \$3/per normal item. All prices subject to change without notice.

Established 1983. We carry over 1,100 different products. Call today for complete technical information and advice, our catalog, literature, and solid value.

5-B Pond Park Road
Hingham, MA 02043
Main: 800-421-8006
or 617-740-2510 12/88
Telex: 671-5348
FAX: 749-2018

800-421-8006

HOURS:
M-F 8:30 - 8:00
Sat: 10:00 - 4:00

CHAOS MANOR

You must explicitly save your Pipedream files if the machine is to be off for more than a few minutes. Saving isn't easy: the software is extremely awkward, and it requires paging through a number of menus. Although there's a keyboard command that will bring up the "Save File" menu, even after you learn it, you then have to type in the darned filename every time; it won't default to the last one you used, even though you have not changed documents. Because it's awkward, I didn't use it. My fault, I guess; but I didn't, so when I got home, every one of the Pipedream files I'd made at COMDEX had vanished. Worse than that, the machine had clearly managed to reset itself: even the date was wrong.

I don't know if that was the X-ray machine at the airport (neither the SuperSport nor the PC-8201 seems to mind those security systems) or that unsaved files just go away after a while (which is what I suspect), but the fact is that all the work I'd done with the Z88 is gone, and that doesn't put me in a mood to be particularly friendly about the machine.

I still have it, and I'll take it with me on my next trip, which will be to Hawaii. It seems that Freeman Dyson was to be the banquet speaker at a conference on Grand Challenges to Computational Science, and he'll be unable to make it, so they've chosen me as his replacement. I've been walking on air since they told me; in my book, Mr. Dyson is one of the 10 most interesting people I ever met, and I find it enormously flattering to be thought in the same league with him. Anyway, the Z88 will go with me, and I'll be very careful not to use tabs, and to explicitly save all my files; and we'll see if my attitude changes. I sure do like the small size and quiet keyboard.

Ezekial

The Ezekial contest—what should I do with my original Z80 CompuPro—produced a large number of letters. I'll publish some of them, and I'll be sending congratulations to many other letter writers.

It turns out that the Smithsonian Institution does indeed want old Zeke as part of their history of computing display. They'll keep him running, and people can actually tweak him. Given CompuPro's domination of the S-100 market, they wanted a Godbout/CompuPro/Viasyn system anyway, and Zeke was about the best known of those.

Most of the other suggestions had to do with worthy causes. I'm sympathetic to that argument, but old Zeke is not only

continued

UTAH

COBOL™

NEW
VERSION 5.0

\$69.95

For IBM® PC's, XT's, AT's and other DOS machines. Needs only 1 disk drive and 128K memory. This is the one you've heard so much about - with fast compile times, small object code modules, not copy protected, no royalties, and clear error messages. Version 5.0 is based upon ANSI-74 standards with new dynamite features including:

- Nested IF's and nested conditions.
- Indexed files (ISAM) with up to 24 keys (includes START verb). This advanced feature requires the software package Btrieve® which is optionally available.
- ACCEPT (line, column) numerics with decimal point alignment, numeric



checking, AUTO-SKIP, SECURITY, LENGTH-CHECK, EMPTY-CHECK, ATTRIBUTE (color), FROM ESCAPE KEY, DAY, DATE, TIME, DAY-OF-WEEK.

- Fast memory mapped DISPLAY's (line, column) ERASE, BEEP, ATTRIBUTE (color). Can display entire screen with one DISPLAY statement.
- Windowing, pop-ups, color and overlays. This advanced feature requires the software package Saywhat?!™ which is optionally available.
- An easy to use, COBOL source code EDITOR with auto line numbering, A-margin, B-margin tabing with full screen cursor control.

Also available: Utah SuperSort®, a fast sort program callable from Utah COBOL; Utah FORTRAN; Utah BASIC; Utah PASCAL; Utah PILOT. Used by 50,000 professionals, students and teachers in 40 countries. 30-day money back guarantee. Discover the ease and simplicity of COBOL, today!

Phone order rushed
by UPS 2nd Day Air:
(702) 827-3030



Since 1977

Ellis Computing, Inc.
5655 Riggins Court, Suite 10
Reno, Nevada 89502

IBM is a registered trademark of International Business Machines, Inc. Btrieve is a registered trademark of Novell, Inc. Saywhat?! is a trademark of The Research Group. SuperSort is a registered trademark of Micropro International Corporation. Utah COBOL is a trademark of Ellis Computing, Inc. © 1987 Ellis Computing, Inc.

You No Longer Have to Share the Lower 640K With Your Debugger

Periscope I's new board uses ZERO memory in the lower 640K. Yet it has plenty of room to safely store all debugging information, like symbols, as well as the powerful Version 4 software.

Periscope's hardware adds the power to solve the really tough debugging problems.

The break-out switch lets you break into the system any time. You can track down a bug instantly, or just check what's going on, without having to reboot or power down and back up. That's really useful when your system hangs! The switch is included with Periscope I, Periscope II, and Periscope III.

Periscope I has a **NEW** board with 512K of write-protected RAM, user-expandable to 1MB, for the Periscope software, symbol tables, and all related debugging information. Normal DOS memory (the lower 640K) is thus totally freed up for your application, and Periscope is protected from being overwritten by a run-away program. The new board's footprint is only 32K, so you can use it in PC, AT, and 386 systems with EGA/VGA and EMS boards installed (not possible with the previous 56K board). It can also be used with Periscope III to provide additional write-protected memory.

Periscope III has a board with 64K of write-protected RAM to store the Periscope software and as much additional information as will fit. AND...

The Periscope III board adds another powerful dimension to your debugging. Its hardware breakpoints and real-time trace buffer let you track down bugs that a software-oriented debugger would take too long to find, or can't find at all!

The Periscope III hardware-breakpoint board captures information in real-time, so you'll find bugs that can't be found with a software-based debugger.

Periscope's software is solid, comprehensive, and flexible.

It helps you debug just about any kind of program you can write... thoroughly and efficiently.

Periscope's the answer for debugging device-drivers, memory-resident, non-DOS, and interrupt-driven programs. Periscope works with any language, and provides source and/or symbol support for programs written in high-level languages and assembler.

David Nanian, President of Underware, Inc. (of BRIEF fame) says this about the new Periscope Version 4:

"Periscope has always been an unbelievable assembler-level debugger. Version 4 has turned it into a terrific source-level debugger as well. Aside from major enhancements like the source-level improvements, all the little changes make a really big difference, too. For instance, symbol lookups and disassemblies are noticeably faster, and highlighting the registers that have changed really makes life easier. Once again, Periscope has raised the industry standard for debuggers!"



Periscope software & 250+ page manual

**NEW
Model I Board**



The **NEW** Periscope I memory board keeps all debugging information out of the lower 640K. Can be used in PCs, ATs, and 386s with both EGA/VGA and EMS boards installed. The Periscope break-out switch enables you to recover from a hung system. Included with Models I, II, and III.

What's New in Periscope Version 4:

- View local symbols from Microsoft C (Version 5)
- Debug Microsoft windows applications
- Set breakpoints in PLINK overlays
- Improved source-level support
- Monitor variables in a Watch window
- 80386 debug register support
- Debug using a dumb terminal
- PS/2 watchdog timer support
- Use mixed-case symbols
- Set breakpoints on values of Flags
- Much more!

- **Periscope I** includes a **NEW** full-length board with 512K of write-protected RAM; (user-expandable to 1MB); break-out switch; software and manual for \$795.
- **Periscope II** includes break-out switch; software and manual for \$175.
- **Periscope II-X** includes software and manual (no hardware) for \$145.
- **Periscope III** includes a full-length board with 64K of write-protected RAM, hardware breakpoints and real-time trace buffer; break-out switch; software and manual. Periscope III for machines running up to 10 MHz with one wait-state is \$1395. Plus the new Model I board, \$1995.

Due to the volatility of RAM costs, prices on board models are subject to change without notice.

REQUIREMENTS: IBM PC, XT, AT, PS/2, 80386 or close compatible (Periscope III requires hardware as well as software compatibility, thus will not work on PS/2 or 80386 systems); DOS 2.0 or later; 64K available memory (128K at installation time); one disk drive; an 80-column monitor.

Call us with your questions. We'll be happy to send you free information or help you decide on the model that best fits your needs.

**Order Your Periscope,
Toll-Free, Today!
800-722-7006**

MAJOR CREDIT CARDS ACCEPTED

The
Periscope
Company, Inc.

1197 PEACHTREE ST. • PLAZA LEVEL
ATLANTA, GA 30361 • 404 / 875-8080

BRIEF™ Users: Now you can have fast compilation AND an integrated, productive environment.

Introducing
BRIEF V2.1

Over 5,000 of you were forced to make sacrifices to use BRIEF, The Programmer's Editor. Advanced compilers and new programming environments, like Turbo C and QuickBASIC, took up so much RAM that BRIEF could not fit in the same 640k.

If you wanted to retain BRIEF's uniquely powerful features¹ while working with larger programs, you had to sacrifice speed and continuity. Instead of a tight Edit-Compile-Edit loop, you had to slog through an obsolete Edit-Exit-Compile-Exit-Edit loop.

Now you no longer have to make that sacrifice.

You can enjoy the features¹ that have made BRIEF the best-selling and the best regarded² programmer's editor without sacrificing environment integration.

Version 2.1 of BRIEF can be swapped in and out with a single keystroke — allowing immediate compilation with even the largest compilers: Microsoft C5.0, QuickC, Turbo C, Lattice C, dBLX, FoxBASE+ v2.0, Clipper, etc.

¹ For example: real multi-level Undo (not simply Undo/redo), flexible windowing, unlimited file size, unlimited number of simultaneous files, automatic language sensitive indentation.

² For example:
"The quintessential programmer's editor." — *Dr. Dobbs' Journal* "Right out of the box, it's a versatile, extremely powerful editor that handles most any programming task with aplomb." — *Computer Language* "Simple to learn and use and extremely sophisticated. Strongly recommended." — *PC Magazine* "Not only the best programmer's text editor I've ever seen, but it is also a tour de force in the way it was conceived and implemented." — *Computerworld* "So far surpasses users' expectations that it is revolutionary." — *MicroTimes Magazine* "BRIEF is truly outstanding." — *Microsoft Systems Journal*

Current BRIEF Users:

Call Ann for details on 4 other important enhancements. Registered users of versions 2.0 or 2.01 update for only \$35.

Haven't tried BRIEF yet?

BRIEF retails for \$195. Call Ann today for a no-risk, 60-day trial with a full, money-back guarantee.

Call toll-free today
800-821-2492

**Solution
Systems**

541 Main Street, Suite 410
South Weymouth, MA 02190
617-337-6963

pretty old, he wasn't all that standard as a CP/M system to begin with; he really was state of the art. It takes a fair amount of expertise to keep him running; and few (I think none) of the worthy causes, such as a school on a Native American reservation, would have that capability. Bill Godbout would try to support Zeke (he's still supporting ancient Z80 systems), but that wouldn't be simple if Zeke were being used by people who didn't understand him, and especially if he were at a remote and unsophisticated location.

It was no easy decision, but I'm going

to let the Smithsonian have old Zeke. I think he'll be happy there. It's pretty dumb to be this sentimental about a machine, but I certainly am. Farewell, old friend. I'll come see you sometimes.

Winding Down

I'm out of space, and I haven't even got started good. At COMDEX both Atari and Commodore showed new stuff. The Amiga has a new Unix configuration that I can't wait to try out; one of the high points of COMDEX was watching Dr. Henri Rubin demonstrate upcoming Amiga technology. Formidable! Atari

Items Discussed

APX-3200	\$2675	Peter Norton Computing, Inc. 2210 Wilshire Blvd., Suite 186 Santa Monica, CA 90403 (213) 391-2000 Inquiry 1029.
ConvertUnits for desk accessory or HyperCard	\$59.95	Logic Gem
for both	\$74.95	Sterling Castle Software 702 Washington St., Suite 174 Marina Del Rey, CA 90292 (213) 306-3020 Inquiry 1030.
GTA 815 Princess Ave. Vancouver, BC Canada V6A 3E5 (604) 255-8077 Inquiry 1025.		Peabody
DESQview 386	\$189.90	Copia International, Ltd. 1964 Richton Dr. Wheaton, IL 60187 (312) 665-9830 Inquiry 1031.
Quarterdeck Office Systems 150 Pico Blvd. Santa Monica, CA 90405 (213) 392-9851 Inquiry 1026.		TianMa
Flicker Master	\$17.95	Asiacom 2761 McColl Pl. Victoria, BC Canada V8N 5Y8 (604) 477-7829 Inquiry 1032.
TSR Hutchinson Co. 110 West Arrowdale Houston, TX 77037 (713) 448-6143 Inquiry 1027.		Visual Edge
GRASP	\$149	Intel Corp. 3065 Bowers Ave. Santa Clara, CA 95051 (408) 765-8080 Inquiry 1033.
Paul Mace Software, Inc. 400 Williamson Way Ashland, OR 97520 (503) 488-2322 Inquiry 1028.		Z88
Instant Access	\$100	Cambridge North America 615 Academy Dr. Northbrook, IL 60062 (312) 564-5512 Inquiry 1034.
Norton Guides	\$69 each	
Norton Utilities 4.5 standard	\$100	
advanced	\$150	

has a lot of nifty new stuff as well. Both computers can use transputers to speed up very large visual displays. I was enormously impressed with both machines; for reasons I haven't time to go into, I think the Amiga has improved even faster than the Atari, but both are definitely worth watching. Each has a shot at being a serious rival to the Sun workstation at half the cost.

On that score, I'm supposed to get a new Sun386i in the next few weeks. I told Sun to keep the total list cost of what they send to below \$20,000. That's still steep for the average BYTE reader, but at least it isn't out of sight; you can pay a good fraction of that for an all-up Mac II or a PS/2 Model 80.

I ought to mention Flicker Master, which is a screen cover that you Velcro over your Amiga monitor; it reduces the flicker from interlaced mode something wonderful. We've had one on my Amiga for a couple of weeks, and I wouldn't be without it.

I've got a whole bunch of animated displays built up from GRASP, Paul Mace's screen utility program; indeed, GRASP seems to have spawned a whole new category of consultants, like, for example, Robert Hurt's Trebor Truh Productions (2284 Almaden Rd., San Jose, CA 95125, (408) 723-0931), which puts together high-quality presentations built up from GRASP. If you have good artists in-house, get GRASP for them; but if you don't have artists, you can still get professional-quality presentations with outfits like Trebor Truh. Then you can present them with Traveling Software's color gizmo that sits on top of your View-Graph projector and flashes up what's on your screen.

There's more, but I'm *really* out of space. The book of the month is by Charles Murray, *In Pursuit of Happiness* (Simon and Schuster, 1988); this may be the most important book published last year.

COMDEX was exhausting, but fun. I sure like these little machines. ■

Jerry Pournelle holds a doctorate in psychology and is a science fiction writer who also earns a comfortable living writing about computers present and future. Jerry welcomes readers' comments and opinions. Send a self-addressed, stamped envelope to Jerry Pournelle, c/o BYTE, One Phoenix Mill Lane, Peterborough, NH 03458. Please put your address on the letter as well as on the envelope. Due to the high volume of letters, Jerry cannot guarantee a personal reply. You can also contact him on BIX as "jerry."

1	Exxon	25	Standard Oil (Ohio)	49	Consolidated Foods
2	General Motors	26	AT&T Technologies	50	Lockheed
3	Mobil	27	Boeing	51	Georgia-Pacific
4	Ford Motor	28	Dow Chemical	52	Monsanto
5	IBM	29	Allied	53	W.R. Grace
6	Texaco	30	Eastman Kodak	54	Signal Companies
7	E.I. du Pont	31	Unocal	55	Anheuser-Busch
8	Standard Oil (Ind.)	32	Goodyear	56	Nabisco Brands
9	Standard Oil of Cal.	33	Dart & Kraft	57	Johnson & Johnson
10	General Electric	34	Westinghouse Elec.	58	Coastal
11	Gulf Oil	35	Philip Morris	59	Raytheon
12	Atlantic Richfield	36	Beatrice Foods	60	Honeywell
13	Shell Oil	37	Union Carbide	61	Charter
14	Occidental Petroleum	38	Xerox	62	General Mills
15	U.S. Steel	39	Amerada Hess	63	TRW
16	Phillips Petroleum	40	Union Pacific	64	Caterpillar Tractor
17	Sun	41	General Foods	65	Aluminum Co. of Amer.
18	United Technologies	42	McDonnell Douglas	66	Sperry
19	Tenneco	43	Rockwell Int.	67	Gulf & Western Ind.
20	ITT	44	PepsiCo	68	Continental Group
21	Chrysler	45	Ashland Oil	69	Bethlehem Steel
22	Procter & Gamble	46	General Dynamics	70	Weyerhaeuser
23	R.J. Reynolds Ind.	47	3M	71	Ralston Purina
24	Getty Oil	48	Coca-Cola	72	Colgate-Palmolive

27 million Americans can't read. And guess who pays the price.

While American business is trying to stay competitive with foreign companies, it's paying an added penalty. The penalty of double-digit illiteracy.

Believe it or not, 27 million American adults can't read and write. Another 47 million are literate on only the most minimal level. That adds up to almost one third of our entire population... and probably a disturbing number of *your* employees.

What does illiteracy cost you? Get out your calculator. Illiterate adults make up 50%-75% of our unemployed. Every year they cost us an estimated \$237 billion in lost earnings. They swell our welfare costs by \$6 billion annually and diminish our tax revenues by \$8 billion.

Illiteracy costs you through your community, too. It robs the place where you work and live of its resources. It undermines the potential of the people who make your products and the people who buy them. No dollar figure can be assigned to this. But over the years, this may be the costliest loss of all.

What can your company do about this? It can join in local efforts to fight illiteracy. It can volunteer company dollars and facilities for better school and tutorial programs. It can invest in a more literate community.

The first step is to call the Coalition for Literacy at **1-800-228-8813** or fill out the coupon below. Do it today. You may find it's the greatest cost-saving measure your company has ever taken.

**A literate
America
is a good
investment.**



Coalition for Literacy

I want my company to join the fight against illiteracy. Please send brochure with additional information.

We want to discuss funding the Coalition for Literacy. Please have a representative contact me.

Name _____

Title _____

Company _____

Address _____

City _____ State _____ Zip _____

Phone _____

Please return to: Coalition for Literacy
Business Division
PO Box 81826
Lincoln, NE 68501-1826

AW...WHAT THE HECK!

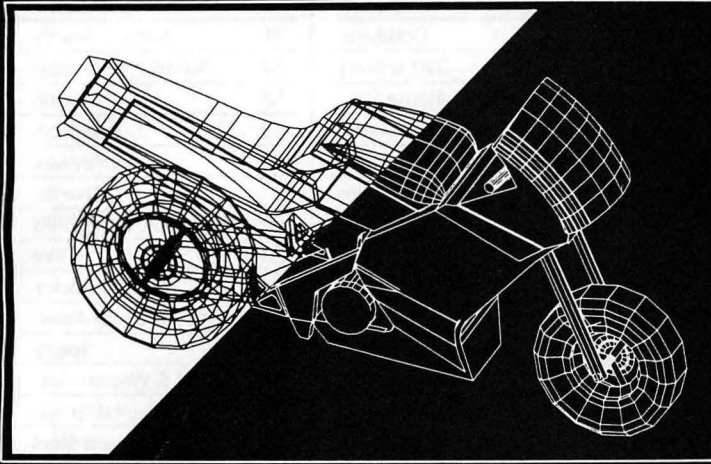

The first question asked by many people is, "Why is *DesignCAD 3-D* priced so low?" The answer? After developing *DesignCAD 3-D* we were unable to decide how the product should be priced. We consulted experts. We used the finest spreadsheets on the market. We took employee polls. We asked our lawyers and accountants for their opinion. We even asked our Mothers, Wives, and childhood Sweethearts! Finally in the greatest American Tradition, we said, "Aw... What the Heck! Let's see the other guys beat this price!" *DesignCAD 3-D* sells for \$299 complete. No add-ons, nothing else to buy!

DesignCAD 3-D is a complete 3-Dimensional CAD system. It offers most, if not all, the features found on programs costing more than \$3000! In fact, **PC Magazine** says, "For a low-cost, self-contained 3-D package *DesignCAD*'s range of features steals the show. The package offers more than adequate features for a wide range of professionals and hobbyists alike."

Once again, American Small Business Computers has proved that you don't have to spend a lot of money to get quality software. *DesignCAD 3-D* provides features such as Shading, Solid Object Modeling, Hidden Line Removal, Cross Sectioning capability, ability to output shaded drawings to laser printers, dot-matrix printers, or pen plotters, extensive file transfer capability, *all for only \$299!* No other 3-Dimensional CAD system can come close to providing the price/performance of *DesignCAD 3-D*.

There is a very important reason to buy *DesignCAD 3-D* other than price: PERFORMANCE! *DesignCAD 3-D* provides complete 3-Dimensional drawing capabilities. It's not a "warmed-over" 2-D program. *DesignCAD 3-D* allows you to draw any entity in 3-D space. This means, for example, that you can draw a curve in the shape of a spring. You can draw a circle or arc at ANY angle on ANY plane.

DesignCAD 3-D allows up to 4 simultaneous views - any angle or perspective - on the screen. *DesignCAD 3-D* also provides complex extrusions—linear, scalar, and circular. Extensive 3-D text capabilities and auto-dimensioning are provided, *at no extra charge, of course!*

DesignCAD 3-D almost certainly is compatible with the computer system you now own. *DesignCAD 3-D* supports more than 200 dot-matrix printers, at high resolution. *DesignCAD 3-D* supports more than 80 plotters, and most digitizers, mice, and graphics adapters available for "PC and PC Compatible" systems. Shaded and wireframe models can be output to the printer or plotter YOU own.

DesignCAD 3-D provides the capability to read drawings from most other CAD systems (*DesignCAD/ProDesign II*, *AutoCAD's DXF*, *Hewlett Packard's HPGL*, and *IGES*). *DesignCAD 3-D* will also write GE, and POSTSCRIPT files. This file exchange utility is included at no extra charge, of course.

DesignCAD 3-D does not require expensive graphics adapters and monitors - even shading can be done on ordinary displays, such as the Enhanced Graphics Adapter (EGA), Color Graphics Adapter (CGA) and Hercules Monochrome Adapter. *DesignCAD* also supports many of the ultra high resolution graphics adapters, with more hardware being supported daily.

However, the best reason to buy *DesignCAD 3-D* is not the low price. It's not the outstanding performance. It's not the extensive hardware compatibility. *The best reason to buy DesignCAD 3-D is for its amazing ease of use!*

What else do you need to know about *DesignCAD 3-D*? Only this: "Included at No Extra Charge." What is included at no extra charge? **EVERYTHING! \$299 BUYS IT ALL!**

\$299

DesignCAD 3-D

Oh yes, we also market a 2-Dimensional version of *DesignCAD 3-D* with special drafting and design functions. Can they work together? Naturally... Our Mothers, Wives, and childhood Sweethearts would see it no other way! The price?... **\$299, of course!**

How do you get one? See your local computer store or dealer, or contact:

To quote **PC Magazine**...

"*DesignCAD 3-D*, the latest feature-packed, low-cost CADD package from American Small Business Computers, delivers more bang per buck than any of its low-cost competitors and threatens programs costing ten times as much."

American
Small Business Computers, Inc.

327 So. Mill Street • Pryor, OK 74361
Phone: (918) 825-4844 Fax: 01-918-825-6359
Telex: 9102400302

Write or phone us for FREE DEMO DISK and information on *DesignCAD 3-D* and *DesignCAD 2-D* products.



NEW FRIENDS AND OLD

Integrated software, special-purpose pseudocomputers, and software that can guide your next career move

Integrated software has gotten a bad rap over the years, largely because some of the most prominent examples of the genre failed to live up to both the claims of the manufacturers and the expectations of the users. Anyone who has watched this scene for the past 5 or 6 years will remember Ovation, which was to be the ultimate integrated software package of which we'd all been dreaming. Unfortunately, it turned out to be an elaborate hoax; after a lot of hoopla and media attention, the product and the company behind it went up in a puff of smoke.

There was VisiON, the slowest windowing environment ever marketed. Context MBA, running under the p-System, flopped while trying unsuccessfully to become the major competition to Lotus 1-2-3. In more recent software history, there was the pitiful rise, rapid descent, and eventual mercy killing of Modern Jazz on the Macintosh.

The list goes on and on. Products that have achieved modest success have done so in the face of contempt from all the gurus, who have maintained that the individual modules of any integrated software package could never rival the power and functionality of stand-alone programs. That criticism is still leveled today, almost as a reflex, at any product that calls itself integrated.

Rubbish. The fact is that while other software has been improving steadily, integrated software has improved as

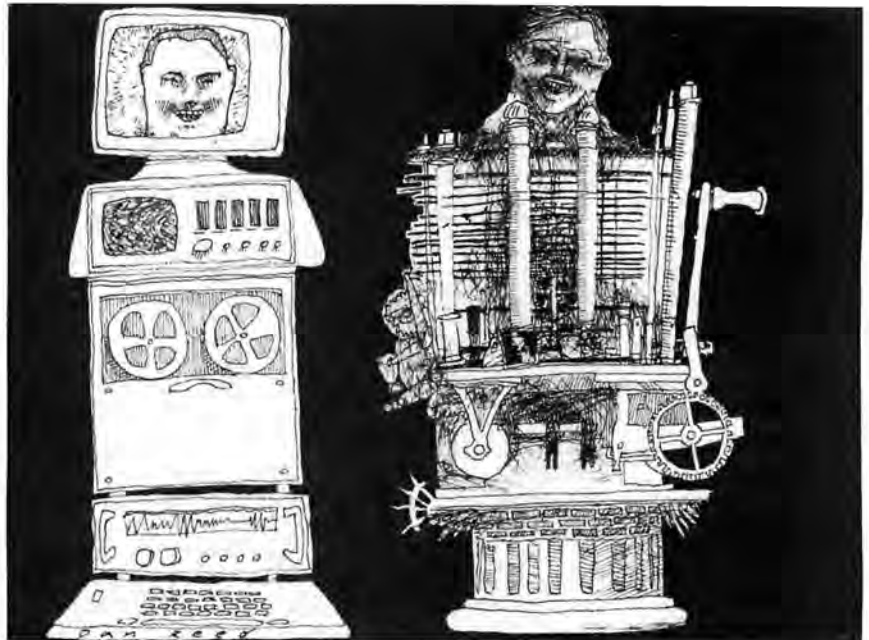

well. While the experts weren't looking, a number of programs have established themselves quite solidly in the marketplace. Think of AppleWorks, the Smart series, Microsoft Works on both the IBM PC and the Mac, SideKick Plus, and Framework III. All are excellent, and all have developed loyal followings.

And don't forget that the definition of "integrated" has also changed significantly. Lotus 1-2-3 was labeled an integrated package when it was first released because it combined the capabilities of a spreadsheet, database, and graphics program. By that standard, almost all software available currently would fit under the integrated umbrella. What would you call a word processor that was a text editor, formatter, spelling checker, thesaurus, outliner, calculator, file conversion utility, mailing-list manager, filing system, and desktop publishing package rolled into one? A few years back, we would have said it was an integrated whizbang; today, it's just an average

word processor. We've come to take integration for granted. Where do you draw the line?

There's something in me that still yearns for the perfect integrated software package, designed as such from the ground up, rather than by patching functionality into another paradigm. I want to have the computerized equivalent of a Swiss army knife. Operating systems and many stand-alone programs have become so cumbersome that I see integrated software as the best way to achieve consistency and simplicity in my work environment. I don't know if I'll ever find what I'm after; perhaps my needs are so personal that they can't be met by any commercial product. I choose to go on hoping.

Once More with Framework

I got started thinking about integrated software because I've been working with Framework III and a Canon Cat for the

continued

90% of the world are still waiting. What the hell are those importers doing?

Printer Buffer inside cable.
For the average user, most buffers are too complicated. So we designed a buffered cable with 64K or 256K inside.
Just a cable. As easy to use. Nearly as inexpensive.



Battery-operated data buffer
Up to 128K with parallel or RS232-input, will hold data for as long as 3 years. Record and play as often as you like. Carry data to a printer or to another computer.



Share your printer.
Forget these boxes that occupy a lot of your desk space. Forget the times when you had to switch manually. We have a cable that allows two computers to share one printer automatically.



That's what T-switches should look like!
For IBM-compatibles. 2 printers to one computer. Complete set incl. all cables and a small switch-box.
Just a cable. No bulky box.



Isolating line drivers
If a line driver is not optically isolating, you might face problems arising from different mains supplies. That's why our RS232-drivers are 100% isolated up to 1,000 volts.



Data Isolators
Transients on the mains supply or electrostatic discharges can cause erroneous data transmissions and even destruction of computers. We offer optical isolators up to 50kV.



Terminal bus.
Connect up to 16 terminals to one 2-wire bus. Save installation costs and gain flexibility and ease of use. Terminal-Bus-Adaptors includes 1kV optically isolated line drivers.

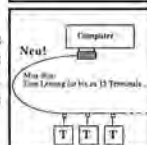

Interfaces.
We have a complete line of interfaces: 20mA, Atari130, C64/128, Centronics, IEEE488, RS232, RS422, RS423 and RS485. (The following are registered trademarks: Atari, C64, CI28, Centronics, IBM)



Austria:	Basic, Wien	0222-9505410
Denmark:	Jatec, Spentrup	06-479139
France:	Necl, Strassbourg	(88) 623752
Singapore:	Overseas Trade	733-4577
Switzerland:	Weber&Co, Zürich	01-9302003
USA:	Tectrans, L.A.	(818) 2853121

Manufacturer and Exporter:

wiesemann & theis gmbh
MIKROCOMPUTERTECHNIK

winchenbachstr. 3-5 phone: ++ 49-202-505077
d-5600 wuppertal 2 telex: 859 16 56
west-germany fax: ++49-202-511050

APPLICATIONS PLUS

past month, two radically different approaches to the question of integration. I have been a loyal booster of Framework ever since I saw it some months before its acquisition by Ashton-Tate. I liked it then and I like it now, and the \$695 price tag still gets you one of the best bargains in the software business.

The Canon Cat is perfect for someone who needs industrial-strength editing and record keeping but doesn't require a full-blown computer system.

Within a character-oriented windowing environment that looks a lot like the Systems Application Architecture interface (though it's largely incompatible with IBM's guidelines), you get a word processor, spreadsheet, database, communications module, and an outliner that also serves as the organizing tool with which to link documents of different types. Framework III is a good choice for anyone with a limited budget who isn't afraid of real power.

However, perhaps the biggest change from Framework II to Framework III is a repositioning of the product in Ashton-Tate's marketing scheme, which should tell you a great deal about what I think of the upgrade. The company is now calling Framework "decision support software," whatever that means. I guess touting Framework's all-around power hasn't yielded large-enough sales to keep Ashton-Tate happy, so the company is now yammering about Framework's ability to get you lots of different types of information at once, so you'll have all the facts you need at your fingertips. In that sense, the product is no different from its predecessors. You do get a large number of nice new touches, but if you haven't been seduced by earlier versions, Framework III has nothing magical enough to make you change your mind.

Every module has been improved. The

word processor now boasts a standard ruler line with tab stops and all the usual stuff, so you have to resort to FRED, Framework's arcane programming language, only in dire emergencies. The excellent spelling checker has gained a companion thesaurus. The spreadsheet features sectional recalculation, so you don't have to wait for every cell to be updated if you don't need to.

The database is vastly improved, to the point where it's quite usable; in earlier versions, there was no easy way to specify field formats, so a ZIP code or an address that started with a numeral entered without a leading space was interpreted as a formula. The communications module has added more protocols and function keys linked to specific entries in the dialing directory. An optional package gives you electronic mail on a network. Oh yes, you also get selectable color and official mouse support. And everything seems a tad faster than before.

Some of the old problems remain, and one new one has been added. Framework III occupies well over 2 megabytes of disk space, so it's difficult to run without a hard disk drive and thus unsuitable for many laptops. FRED is probably the most difficult macro language around. Figuring out how to link files for output is no mean feat without cracking the manual. You can't add to the dialing directory without running the installation program. You've heard all this before.

The new problem is one on which mine might be a minority viewpoint. It used to be that if Framework encountered a blank cell in the spreadsheet or field in the database, it would give an error message when calculating. I thought this was a pretty good safety check, but it's not the way Lotus 1-2-3 does it. Framework III now treats nulls as if they were zeros, in the Lotus fashion, and computes results even if you've left something out. Phooey.

On the whole, the enhancements to Framework strike me as improvements to an already solid product, but not enough to cause a Framework II user to spring for an upgrade. I was no more impressed with the program than I was the last time I looked at it. Is that damning with faint praise? I'm not sure.

In many respects, Framework is beginning to show its age. Features that caused my jaw to drop when I first saw them are now fairly common in today's software marketplace; Framework III is no longer a revolutionary piece of software. I think it's terrific, but it's lost that mind-boggling tingle. I honestly don't

continued



BASF
10 Diskettes
3.5" - 2DD

BASF
Diskette
3.5" - 2DD
Two sides
Double density
125 to centimeter

**Create a 3.5"
Micro Diskette
with unlimited
protection against
a hostile world.**

You're covered. BASF molds the rigid plastic jacket of its 3.5" Micro Diskette to its own specifications, providing unsurpassed protection for the flexible disk within. Call 800-343-4600 for the name of your nearest supplier.

The Spirit of Innovation.

Circle 31 on Reader Service Card



BASF

Items Discussed

Canon Cat.....\$995
 includes Canon 180 printer
 Canon U.S.A., Inc.
 One Canon Plaza
 Lake Success, NY 11042
 (516) 488-6700
Inquiry 1021.

Framework III\$695
 Ashton-Tate
 20101 Hamilton Ave.
 Torrance, CA 90502
 (213) 329-8000
Inquiry 1022.

The Perfect Career..... \$49.95
 Mindscape, Inc.
 3444 Dundee Rd.
 Northbrook, IL 60062
 (312) 480-7667
Inquiry 1023.

know how much further the program can be taken.

On the other hand, to anyone willing to commit to it, Framework III offers a flexible application development environment, a beautifully consistent command set, and modules as good as many top stand-alone programs. The fact that I've begun to yawn a little shouldn't be construed as a discouraging sign.

Nice Kitty

With its software in ROM, the Canon Cat has the most consistent integrated interface I have ever used. The machine is not exactly a computer as such. It looks like a computer—with a black-on-white monitor, keyboard, and disk drive—but it's, well, different.

I'll spare you a rehash of the physical description, which I detailed last month.

When you turn on the Cat, the screen is set up for entering text. Just plug in a disk and start typing. Dynamic page breaks are automatic; one keystroke can force a break or begin a new document. Everything is stored as a continuous text scroll; there's no discrete operating system. You move by searching for text; two pink keys in front of the space bar initiate forward and backward searches, or leaps in Cat jargon.

The cursor moves after each keystroke, so you rarely have to type a full word to reach its next occurrence. The

Leap keys also serve as left and right arrow keys. To highlight for copying, deletion, or printing, leap to the start of a block, leap to the end, then punch both Leap keys to highlight.

Commands are triggered by Control-key sequences, and the functions are printed on the front of the key caps. The "Control" key is labeled simply Use Front. If you need help, hold down the Use Front key, press a key called Explain, then any key you don't understand. Presto—you get one of 48 help screens.

The Calc key yields a result from any highlighted formula, which then appears with a dotted underline. Pressing Calc again expands to the original formula for editing. You construct pseudospreadsheets by tabbing columns of numbers and using the Calc command to enter named variables and cell references. You can even embed variables and references in text paragraphs, so you've got the equivalent of free-floating cells in flowing text.

Where the Cat falls down is in formatting for output. Page numbers are centered at the bottom of every page, and there's no facility for headers or footers. You can leave off the number by highlighting less than a full page, and you can create macros that insert headers or footers onto pages, but it's really kind of primitive. Jef Raskin, whose team at Information Appliance designed the Cat, points out that it doesn't substitute for a computer. The Cat isn't intended for multicolumn page layout, shop-floor data analysis, or multiuser access. It's fine for basic text, simple spreadsheets, communications, free-form databases, and the like.

Recommendations? The Cat is perfect for someone who needs industrial-strength editing and record keeping but doesn't require a full-blown computer system. If you're willing to invest a little time and you're capable of throwing out your notions of what constitutes "power computing," get a Cat for yourself. It's as close to perfect integration, on a small scale, as I've encountered to date.

When I Grow Up

Every month or two, I receive the latest batch of games from Mindscape, which usually get thrown into a box in the garage and forgotten. Because it arrived with two awful-looking shoot-'em-ups, I nearly missed The Perfect Career (Mindscape, \$49.95) and heaved it into the box with the rest. That would have been a major mistake, as it is anything but a game. It is an MS-DOS program designed to aid in the process of career

counseling. You use it to match your interests and qualifications with potential employment categories.

The Perfect Career offers two complete testing and evaluation units, one for high school students with no professional experience, and one for adults with more knowledge of real-world abilities. In either case, you rank an extensive list of job situations on a 1 to 3 scale for interest and/or skill. The program derives an assessment of how your expectations match up to your answers, and it suggests a list of possible careers. I took the adult test, and I was amazed at how accurately the program pegged me; all the jobs it generated were things I'd enjoy doing. As an example, the program was canny enough to list "college or university president" as a choice but not "college or university professor," which meshes squarely with my impatience for teaching.

I then tried it on someone else, with somewhat less satisfactory results; the program produced only a terse list of the most obvious possibilities. When I asked my guinea pig about the process, she admitted she had given top scores to those things she liked and knew she could do and bottom scores to everything else. The Perfect Career then told her, naturally, what she already knew. I can't blame the program; the tests need to be taken with a lot of thought and a definite seriousness of purpose.

The program was developed by James C. Gonyea, director of the New England Center for Career Development. He also wrote a brief but helpful manual that sketches a systematic approach to choosing a career that goes well beyond the simplistic nature of the testing software. The Perfect Career is a complete package, and it makes an intelligent aid for students looking for career directions and adults who are thinking about making a switch.

Don't expect The Perfect Career to tell you exactly what you should do with your life; only you can make that decision. But the program can give you some insight into your desires and aptitudes and help you narrow your focus. It's no magic bullet, but it's pretty slick. I recommend it. ■

Ezra Shapiro is a consulting editor for BYTE. You can contact him on BIX as "ezra." Because of the volume of mail he receives, Ezra, regretfully, cannot respond to each inquiry.

Your questions and comments are welcome. Write to: Editor, BYTE, One Phoenix Mill Lane, Peterborough, NH 03458.



Create a high capacity Diskette with no capacity for error.

Make no mistake. Every bit, every byte, on every track of each BASF 5.25" HD Diskette is certified 100% error-free and warranted for life. Call 800-343-4600 for the name of your nearest supplier.

The Spirit of Innovation.

Circle 32 on Reader Service Card



BASF

FLEXSCAN™ 9070S, PC Hi-Res That Looks Like a Million.

The FLEXSCAN 9070 Multiple Scan monitor is of course compatible with other multi-scans, but includes improvements that will give you the professional edge which is the mark of a good investment.

You can extend your multi-scan range from 20kHz to 50kHz in practical terms.

This means that, at the 48-50 kHz range, you can make use of PC CAD/CAE capabilities at a resolution of up to 1024 dots × 768 lines.

The FLEXSCAN 9070 takes advantage of non-interlace high resolution signal as high as 1024 × 768 to provide you with a flicker free display at much brightness. You can also use the 9070 with IBM PS/2 or VGA compatible boards at a high resolution mode like 800 × 600 and 1024 × 768 (non-interlace).

The FLEXSCAN 9070 provides a 16-inch screen, large enough for CAD/CAE and 3-D projections, yet small enough to fit comfortably into your home work space.



1024 dots × 768 lines Graphics (Non-interlace)
AutoCAD



Also, for your convenience, all controls and switches, including the alternate video input, are located within easy reach on the front panel. The FLEXSCAN 9070 is compatible with a wide range of IBM, Apple, and other products, allow you to use all of today's popular programs---at a resolution that looks like a million.

FLEXSCAN™ MODEL 9070S

- IBM VGA(PS/2), 8514/A, PGC, EGA compatible and CAD/CAE use.
- Apple Mac. II and SuperMac Spectrum compatible
- Max. 1280 dots × 800 lines high resolution
- 1024 dots × 768 lines display on Non-Interlace signal delivers flicker-free high-res graphics
- 20kHz to 50kHz horizontal scan automatic adjustment. 50Hz to 80Hz vertical scan automatic adjustment
- 16 inch, 0.31mm dot pitch and newly developed XF(Extended Field) Gun to obtain both brightness and sharp focus.
- Front mounted controls including the input signal select switch between 2 video input.
- Selecting white or Amber displays colored application in shades of gray or amber
- Tilt-Swivel stand standard

NANAO®

NANAO USA CORPORATION

23510 TELO AVE., SUITE 5 TORRANCE, CA 90505
PHONE (213) 325-5202 FAX (213) 530-1679

Specifications are subject to change without notice.

APPLE, Macintosh II are registered trademarks of Apple Computers Inc. ARTIST, ARTIST 1 Plus, ARTIST 10, ARTIST 10/16 are trademarks of Control Systems Inc. IBM, IBM PC, XT, AT and PS/2 are registered trademarks of International Business Machines Corporation. SuperMac is a trademark of SuperMac Technology. SuperEGA HiRes, SuperVGA and SuperVGA HiRes are trademarks of Genoa System Corporation. Orchid Designer VGA, Orchid Designer VGA-2, TurboEGA and TurboVGA are trademarks of Orchid Technology. Paradise VGA Professional Card, Paradise VGA Plus Card and Autoswitch EGA are trademarks of Paradise Systems, Inc. Paradise Systems is a registered trademark of Paradise Systems, Inc. VEGA Deluxe and VEGA VGA are trademarks of Video-seven Inc. Metheus is a registered trademark of Metheus Corporation. Imagraph is a trademark of Imagraph Corporation. AutoCAD is a registered trademark of Autodesk Inc. GEM is a registered trademark of Digital Research Inc. Lotus and 1-2-3 are registered trademarks of Lotus Development Corporation. SigmaVGA and SigmaEGA are trademarks of Sigma designs, Inc. FLEXSCAN is a trademark of NANAO CORPORATION. NANAO is a registered trademark of NANAO CORPORATION.



GETTING INTO BIGGER LANs

When you have a big job, sometimes you really do need a bigger hammer

The solution to business connectivity is simplicity. By that, I mean that the method you choose should be as simple as possible given the needs of your business. In my last two columns, I discussed the possibility of sharing resources without using a local-area network at all, and of sharing in a small area using a relatively simple LAN such as 10Net. There comes a time, though, when solutions as simple as these won't do the job.

As your office or department grows, the problems associated with managing central data storage and access to resources reach the point where a traditional central server LAN becomes the obvious choice. Eventually, printer servers become overburdened and the cable lengths required are too long to work properly. Likewise, a peer-to-peer network without a file server becomes difficult to manage because individual computers are turned off or files are moved. This makes shared resources difficult or impossible to find or use.

At this stage, in spite of its added complexity and cost, the file server becomes the simpler solution. In short, it's easier to manage a single computer than it is to manage dozens. Of course, a LAN can have more than one server, but you will still use few servers relative to the number of workstations. Likewise, your network printers will be centrally managed, as will other network resources, such as communications gateways.

Covering the Floor

An example of a typical central server LAN is one intended to serve the needs

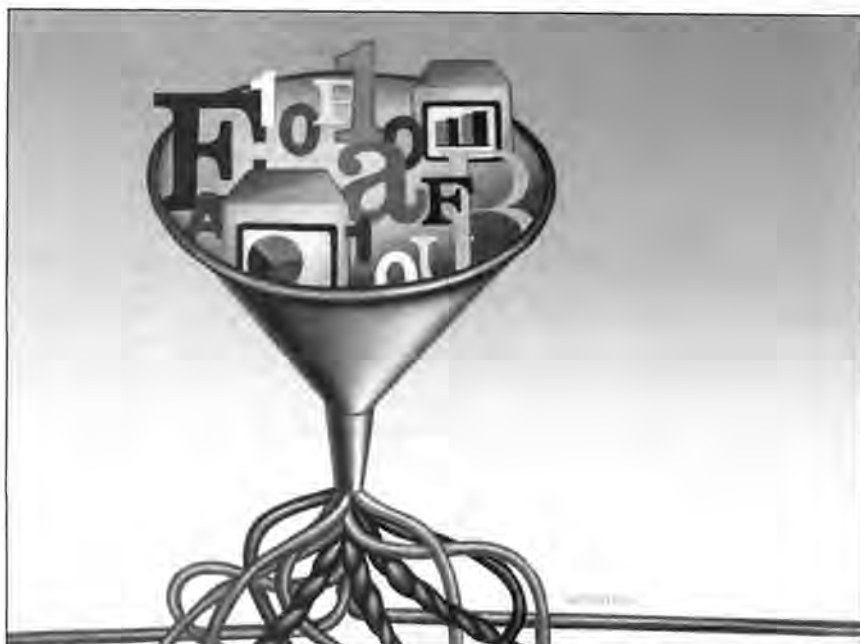

of the employees on a single floor of a professional services company. Say that about 80 employees need to have access to printers, asynchronous communications, some common word processing files, and electronic mail. There is some need for database management using dBASE III Plus. Word processing is performed using WordPerfect 4.2.

Because the employees of this company have very flexible schedules, and because many of them travel frequently, a peer-to-peer network would be quite inconvenient if any of the shared resources resided on any of the individual computers, since there is a virtual certainty that many computers on that floor will be turned off at any given time. Finally, there is a strong move toward the Apple Macintosh in portions of the company, and these need to be connected as well.

What to Do?

What I've laid out here is a situation quite common to many companies with a large

number of office workers. While they may be in groups that vary in size, and while the physical circumstances may vary, the needs will remain. Workers need to be connected so they can make the best use of their available resources.

Now it's time to make some decisions. First, let's consider what sort of LAN you need, then choose LAN software, and, finally, decide what to use for a file server. Before I get deeply involved, though, you need to realize that there's more to LAN selection than I can discuss here. Some of these issues will be covered in later columns.

What Sort of LAN?

There are three factors you should weigh to determine the type of LAN you'll use: hardware requirements, wiring requirements, and expense. You may find that your selection of LANs is restricted because you need Ethernet for your Macintosh or for the VAX in the basement.

continued

Likewise, if your building is already wired for ARCnet, you'll probably use that. Finally, if you have a very limited budget, you may find that you can afford ARCnet but not Ethernet.

Since most buildings aren't wired for LANs ahead of time, you may also find yourself looking for a product that will work with your already-installed twisted-pair wiring. You could also find out that you're going to have to install wiring, no matter what system you pick. This factor takes on added importance, since you may find that the cost of buying and installing the wiring for a LAN exceeds the entire cost of the rest of the network.

Since most personal computer users don't care what LAN protocol they use, Ethernet, ARCnet, or Token Ring, the primary critical factors are the costs to install the wiring and to adapt the computer to work with a network. Another critical factor is a particular computer's ability to work at all with some LAN protocols. For example, if you're using the Macintosh, you can use Ethernet on some later machines such as the Mac II and the SE. Otherwise, you have to use

the standard AppleTalk network and find a way to integrate it.

The LAN Software

The software is the part of a LAN that the user sees. Regardless of the hardware and protocol involved, the user knows that the LAN is running something like Novell NetWare. Thus, you need to make sure you select the LAN operating software with your users' needs, as well as their installed hardware base, in mind.

According to a BYTE survey at PC Expo last July, the most popular network software is Novell NetWare. That survey showed that significantly more than half of all users employ Novell. There are a variety of reasons for this, not the least of which is that Novell has written its network operating system to function with most of the popularly available networks. Also popular, but less common than NetWare, is 3Com's network with its 3+ LAN operating software.

Both of these LAN operating systems are widely used because they make minimal demands of the user. While both require logging onto the network and both may require passwords, to users who

have obtained access to the network, the file server appears to be just another disk drive. Likewise, printing occurs just as it would with a stand-alone computer. Once users have learned how to work their computers, they need a minimum of training to use the network.

Besides supplying access to big disk drives, LAN software typically offers a variety of other functions. One that used to be standard is E-mail. Currently, LAN software companies, including Novell and 3Com, are selling their E-mail software separately. In the case of Novell, because its E-mail product needed improvement, many users bought third-party packages.

The Server

Most companies that sell network software also sell file servers, although Novell has announced that it is leaving this portion of the business and has sold its server line to Samsung of Korea. Basically, the file server is a proprietary version of a personal computer. Usually, a file server has some added features and enhancements that help match it to its dedicated role on the network. Good ex-

A MESSAGE TO OUR SUBSCRIBERS

FROM TIME TO TIME WE MAKE the BYTE subscriber list available to other companies who wish to send our subscribers material about their products. We take great care to screen these companies, choosing only those who are reputable, and whose products, services, or information we feel would be of interest to you. Direct mail is an efficient medium for presenting the latest personal computer goods and services to our subscribers.

Many BYTE subscribers appreciate this controlled use of

our mailing list, and look forward to finding information of interest to them in the mail. Used are our subscribers' names and addresses only (no other information we may have is ever given).

While we believe the distribution of this information is of benefit to our subscribers, we firmly respect the wishes of any subscriber who does not want to receive such promotional literature. Should you wish to restrict the use of your name, simply send your request to the following address.

BYTE MAGAZINE
ATTN: SUBSCRIBER SERVICE
P.O. Box 7643
TEANECK, NJ 07666-9866



DOWN TO BUSINESS

amples are the servers from 3Com that have an AppleTalk port. This feature allows Macs in a LocalTalk network to be added to a 3Com LAN.

Although most LAN companies sell file servers, you can use a personal computer as a file server if you prefer. Normally, the machine you would select as a file server would be an 80286- or 80386-based IBM PC AT clone with a large, fast hard disk drive and some extended memory. Novell and 3Com sell versions of their network operating software for these machines, and they work fine in most environments. In the example mentioned earlier, an 80286 AT clone with a 300-megabyte hard disk drive has proven entirely adequate to support the 80-person group. Had the group been using more database management or transferring large files, such as those generated by a CAD system, an additional or a more capable server would have been necessary.

Selecting a dedicated server depends partially on the load you plan to put on it and partially on other features that the server must have, such as 3Com's AppleTalk port. Likewise, you need to make sure that whatever you pick for a server will have room to support the required circuit cards, which will include one and possibly more network interface cards, additional memory, possibly a copy-protection card (although Novell has just dropped copy protection with version 2.12), and additional communications ports if the machine does not come with enough. Interestingly, the choices of server and network operating software do not have to agree. You can run most network operating software on an AT clone, and you can even run Novell NetWare on a 3Com server.

Choosing Sides

You may find that either network mentioned here will meet your needs and that the dealers in your area will sell them to you for about the same price. Now comes the problem of selecting. At this point, you should involve the dealer. After all, a network that won't work is pretty hard to ship back to the factory, and network manufacturers tend to encourage the involvement of their dealers. Novell, for example, requires you to pay for service through the factory, either through a charge card or a service agreement. You need to make sure that the dealer will return to service the network and solve installation problems, unless you have the ability to do it yourself.

There is, of course, the important question of compatibility. Since Novell's

Items Discussed

Advanced NetWare 2.12 \$2995
 NetWare 2.12 \$1495
 NetWare Requester for
 OS/2 1.0 \$200
 Novell, Inc.
 122 East 1700 S
 Provo, UT 84601
 (800) 453-1267
 (801) 379-5900
Inquiry 981.

EtherLink network adapter ..\$495
 EtherLink/MC
 (Micro Channel)\$595
 EtherLink/NB
 (Macintosh II)\$595
 EtherLink Plus network
 adapter\$895
 3+Open LAN Manager
 Advanced System 1.0 \$2995
 3+Open LAN Manager
 Entry System 1.0\$995
 3Server 3S/400\$12,995
 3Com Corp.
 3165 Kifer Rd.
 Santa Clara, CA 95052
 (408) 562-6400
Inquiry 982.

and 3Com's networks are highly popular, these companies normally support them with applications software. Less-popular networks might not be supported, so you have to check. The ability to support IBM NetBIOS compatibility, as most network operating software does, helps in this case.

Does this look like a lot to go through? Well, it is. Choosing and implementing a large LAN is not a trivial process, and it's made more complicated by the fact that nearly all installations are unique in some way. ■

Wayne Rash Jr. is a consulting editor for BYTE and a member of the professional staff of American Management Systems, Inc. (Arlington, Virginia). He consults with the federal government on micro-computers and communications. You can reach him on BIX as "waynerash," or in the to.wayne conference.

Your questions and comments are welcome. Write to: Editor, BYTE, One Phoenix Mill Lane, Peterborough, NH 03458.

Paul Mace SOFTWARE

hTEST hFORMAT

... Can double your
hard disk performance.

Experience has shown most hard disks are set up wrong . . . which means the interleave is probably wrong and *you are being penalized anywhere from 50 to 600% in performance.*

Included in the hTEST · hFORMAT package is an interleave optimizer, hOPTIMUM. It calculates the optimum value for interleave, then resets the disk, automatically, for peak performance.

The second casualty to improper setup is your data . . . because some hardware vendors take the easy route. They skip low-level testing and entry of manufacturer's bad-track information.

hTEST finds those marginal regions on the disk before they cost you time and information. hFORMAT lets you enter the manufacturer's test information and certify for yourself that the disk is properly initialized for reliable service.

When the worst happens . . . and you lose data, hFORMAT will help recover your disk—even from that ultimate disaster: "Invalid Drive Specification."

hTEST · hFORMAT: for IBM PC, XT, AT and compatible computers. Requires 64K, DOS 1.1 or higher.

**Advanced Hard Disk
Diagnostics designed by
Kolod Research . . . \$89.95**

Paul Mace Software, Inc.

400 Williamson Way
Ashland, OR 97520
(800) 523-0258
(503) 488-2322

(COD's, PO's add \$5.00)
(Foreign orders add \$10.00)

h-Test h-Format is a trademark of Kolod Research Inc.

CONVINCE YOURSELF!
Send us \$1. We'll send you
an interleave test disk.

Q Why Should I Purchase the SIVA 286/386 System?

Complete* 8, 12, 16 and 20 MHz Systems with

SIVA Systems from VNS America Corp. delivers the uncompromising power you want, plus the hardware/software products you need. Promptly. Courteously.

Enjoy the AT®-compatibility, speed and future upgradeability you would expect from up-to-date premium quality computers. And, enjoy the fast service so many have come to appreciate from VNS America Corp.

About VNS America Corp.

VNS America Corp. and its associate companies pool their expertise and buying power to bring you premium, name brand products at breakthrough prices.

We're bold, colorful and innovative. We have to be to gain your attention in this ultra-competitive industry. But, our products and service are first rate because we need your confidence to succeed.

IBM set the standard... we're just making it affordable to thousands of companies, individuals and industry that want quality at the best prices.

TRY US
Call 1-800-252-4212

VNS America Corp.

Suite 270, 910 Boston Post Road
Marlboro, Massachusetts 01752 U.S.A.
In Massachusetts 508-481-3726
FAX: 508-481-2218

The Powerful SIVA 386 System

Standard 386 Features:

- 32-bit Intel 80386-16 CPU.
- 1MB of 32-bit RAM on board. System expandable to 16MB.
- 8/16/20 MHz Keyboard selectable.
- ST-251-1 Seagate 40MB Formatted 28 ms high speed, with ultra high speed Controller 1:1 interleave.
- 1.2MB High Capacity Floppy Drive.
- Super deluxe heavy duty tower case with 6 half-height drive openings.

- High-resolution 12" Non-Glare Amber Display. Tilt and Swivel base, Hercules-compatible Adapter.
- 101 Key Enhanced Keyboard, Pleasant "Tactile/Click" Feel.
- 80287/387 Math-Coprocessors optional.
- Fully compatible with virtually all XT/AT and 386 software.

\$2495

Upgrades for your 386 System:

- VGA Color Upgrade — add only \$495.
- 20 MHz CPU Upgrade — add only \$195.
- Call for all other options and upgrades.



A You will experience unmatched performance using our hardware/software products. And, you will benefit from breakthrough pricing from VNS America Corp.

Premium Name Brand Peripherals and Software!

The Economical SIVA 286

A Complete 12 MHz High-Speed SIVA 286 System with 40MB (28MS-ST251-1) Hard Disk

Complete System Features:

- 80286 CPU, 8/12.5 MHz Dual Speed, Keyboard Selectable
- High-Speed RAM, 512K Expandable to 4MB on the Motherboard (16MB System Total)
- Phoenix BIOS
- 40MB Hard Drive, 1.2MB Floppy Drive
- Ultra High-Speed/Floppy,/Hard Disk Controller 1:1 Interleave, 800KB/Sec Transfer Rate
- High Resolution 12" Amber Display with Tilt and Swivel Base, Compatible Graphics Controller
- Full 101-Key Enhanced Keyboard, Pleasant Tactile/Click Feel
- Two Serial and One Parallel Printer Ports and One Mouse Port
 - 3-16 Bit and 1-8 Bit Free Expansion Slots
 - Clock Calendar with 10-Year Life Battery Backup
 - 80287 Support, up to 12 MHz
 - Meets FCC Requirements

\$1295

Standard System Including all Standard Features except Hard Disk \$995

Lowest Cost Compilable Upgrader

- Additional 512K Memory for \$195.
- 1.5MB Additional Memory for \$395.
- EGA Upgrade for \$295.

Nine Reasons to Call VNS America Now...

- Produced by High Technology Manufacturing Processes
- Fully Surface Mounted Technology
- EGA Controller Standard
- Supports 3.5" and 5.25" Floppy Disks
- 10-Year Battery Life
- Phoenix BIOS
- No Memory Surcharge (We're not opportunists!)
- Same Day Shipment (Competitors often take 4-6 weeks.)
- 100%-Compatible with Your Budget

**Complete: includes 12 MHz high-speed SIVA 286 System with 40 MB hard disk drive, monitor and keyboard.*

VNS America Corp.

**Order Now Toll-Free
1-800-252-4212**

**Complete unit includes CPU, monitor, keyboard and 40 MB hard disk drive.*

Circle 241 on Reader Service Card

We've Invented the Future of Instrumentation Software . . . Twice.

With Words With Pictures

Acquisition

Integrated libraries for GPIB, RS-232, A/D-D/A-DIO plug-in cards, and modular instruments.



Intuitive character-based function panels that automatically generate source code.

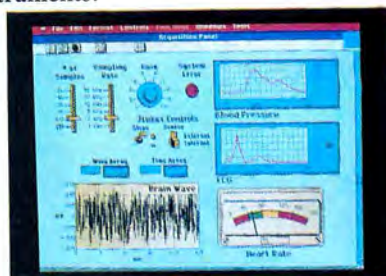

Front panel user interface with virtual instrument block diagram programming.

Analysis

Extensive libraries for data reduction, digital signal processing, and statistical analysis.

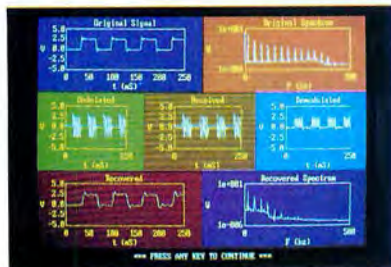

Over 100 analysis functions plus all the built-in functions of your language.

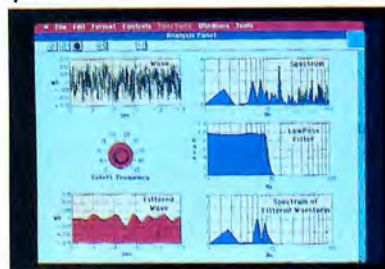

Over 250 icons for computation and analysis.

Presentation

Flexible high-performance graphics and report generation.

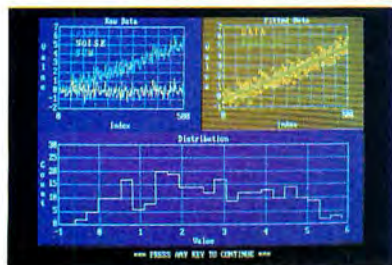

Extensive graphics support for CGA, EGA, MCGA, VGA, and Hercules.



Macintosh Desktop Publishing compatibility.

LabWindows

LabVIEW



LabWindows®
for the DOS-based PC and PS/2,
with Microsoft QuickBASIC or C.

NATIONAL INSTRUMENTS®
The Software is the Instrument™
12109 Technology Boulevard
Austin, Texas 78727-6204
800/531-4742 512/250-9119

LabVIEW®
for the Apple Macintosh.

National Instruments of Japan 81 (03) 788-1921 • National Instruments of France (1) 48 65 33 70 • National Instruments United Kingdom 44-01-549-3444 • ARGENTINA 541/46-5776 /0628
• AUSTRALIA 61 (3) 879-2322 • BELGIUM 02/735.21.35 • CANADA 416/890-2010-613/596-9300-(514) 747-7878-403/295-0822-(604) 988-2195 • CHILE 56 2253689 • DENMARK 45 02-251122
• FINLAND 358 90-372 144 • FRANCE 33 (1) 69077802 • HONG KONG 852 0-262707-852 0-262945 • IRELAND 353 042 72282 • ISRAEL 972 324298 • ITALY 39-2-98491071-2-3 • KOREA (02) 776-38
• MEXICO 52 660 4323 • THE NETHERLANDS 31 070-996360 • NEW ZEALAND 64 09 444-2645 • NORWAY 02-531250 • PORTUGAL 19545313 • SINGAPORE 65 29 11336
• SOUTH AFRICA 27 (011) 787-0473 • SPAIN 34 (1) 455 81 12 • SWEDEN 4608 792 11 00 • SWITZERLAND 41 65 52 8949 • TAIWAN/THE REPUBLIC OF CHINA 886 (02) 7036280 • THAILAND 66 2349330
• UNITED KINGDOM 44 273 608 331 • WEST GERMANY 49 89 807081



HEY APPLE, I NEED A LAPTOP

The time has come for a portable Mac that doesn't strain your arms or your credit line

I can't stand it. I've really tried hard to like the laptops I use each week: a Tandy 200, a Zenith Z-183, and a Toshiba T1000. Despite the virtues of each machine, they just don't go the whole nine yards. They are either too heavy (Zenith), have a lousy display (Tandy), or a crammed keyboard (Toshiba). And they all suffer from that most serious of failings: They aren't Macintoshes! No version of MS-DOS or Tandy software can fill my Mac software void. I don't want to use these machines, but so far, I haven't found a viable alternative.

It's still a nuisance moving files from a laptop to the Mac and back (although Traveling Software's LapLink Mac is a big help). But I don't want to have to transfer files from MS-DOS to the Mac and worry about file format-translation problems in the process. What I really want is to take files from my laptop and use them directly on my home and office machines. Since I use 8-megabyte Mac IIs as my primary personal computers (my Sun-3 Ethernet workstation notwithstanding), my standard computing environment consists of MultiFinder running Word 3.02, FullWrite Professional 1.0, More 1.1c, Excel 1.5, VersaTerm-Pro 3.0, AppleLink 2.0, 4th Dimension 1.06, FoxBASE Plus/Mac 1.1, MacScheme + Toolsmith 1.5, HyperCard 1.2, Smalltalk-80 2.3, and MPW 2.0. I use some or all of this software each week (plus some other programs). Along with ALSoft's MasterJuggler (so I can keep a ton of desk accessories and fonts open simultaneously, too), it's my software of choice. Why should I have to give

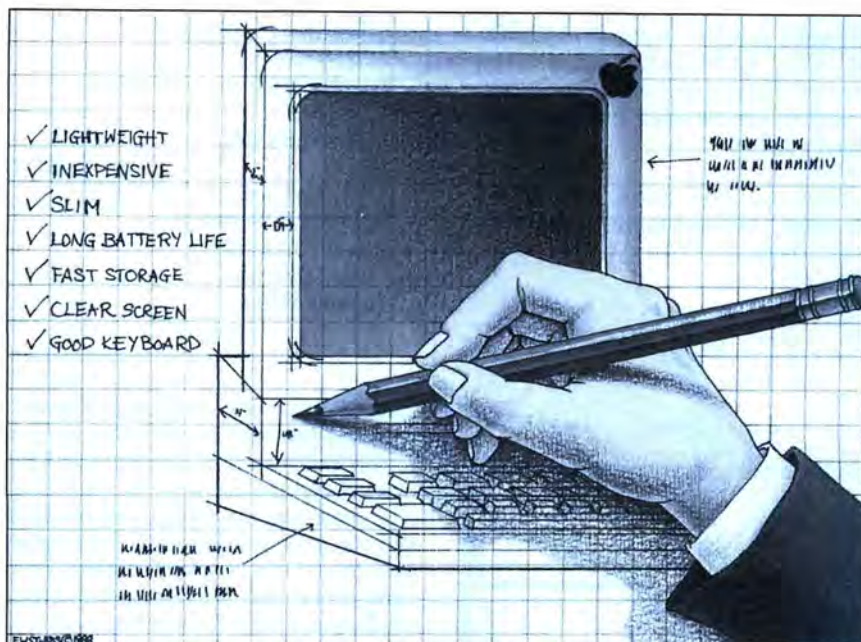

up all of this just so I can carry a computer with me?

Believe me, I've tried the available alternatives and have not been impressed. I used a Dynamac EL for a few days quite some time ago (see "Dynamac's Portable Mac" by Peter Wayner, May 1988 BYTE). Although it's a nice machine with a very nice screen, it's hardly a laptop. The thing weighed more than the Mac SE I've been lugging around on trips. The Dynamac folks need to trim the weight down to something closer to single digits for it to approach laptop status. And it doesn't have batteries, which can definitely cramp your computer-carrying style.

Apple has been rumored to be near announcing a laptop Mac (or Macs) for the last year now. I, for one, am getting sick and tired of waiting. Apple, please get on with it and announce some snazzy laptops soon. Naturally, the laptop Mac we all want must have lots of fast storage, a crystal-clear screen, a great keyboard,

and an 8-hour battery life, weigh under 6 pounds, and cost under \$2,000.

OK, so that's probably a pipedream. I'd settle for a laptop that weighed under 12 pounds, that was slim enough to carry in my briefcase or travel bag without destroying them, and cheap enough that my bank won't revoke my MasterCard when I try to buy it. The battery life is negotiable, I suppose, but it has to at least be a positive number.

It turns out that Colby Computers (who has been making laptop Macs for a couple of years now, by buying Mac Pluses and cutting them up) is about ready to ship a new laptop it calls the WalkMac SE. It will be based on the Mac SE motherboard, will weigh about 12 pounds, and has a backlit LCD screen and a rechargeable battery.

Unfortunately, it's also going to cost more than five grand (\$5449). In the wake of Apple's September 1988 price increases, maybe that doesn't seem so

continued



Break the 32M barrier without breaking your wallet with **EZ-DOS 4.0**.

EZ-DOS 4.0 was developed by **Digital Research** as an alternative DOS for PCs. As such, EZ-DOS 4.0 allows 512M partitions and file/subdirectory **PASSWORD** protection. On-line **HELP** is another user-friendly feature.

EZ-DOS 4.0 also comes with **GEM/3 Desktop**, this windowing operating environment.

GEM Desktop™

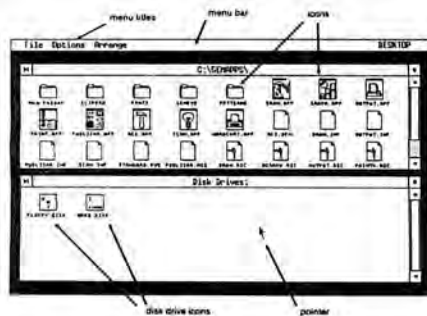

EZ-DOS 4.0 \$79.00
with True BASIC \$99.00

2001 Sales, Inc.

Corp. Headquarters:
16580 Harbor Blvd., Ste. D.
Fountain Valley, CA 92708
Tel: (714) 531-6551 Fax: (714) 531-8546

CANADA:
Tel: (416) 591-6600 Fax: (416) 591-6808

TAIWAN:
Tel: (02) 542-4575 Fax: (02) 536-3405

HONG KONG:
Tel: 5-890-3707 Fax: 5-895-6241

Dealer, Distributor & OEM inquiries welcome.
VISA and Master Card accepted.

Items Discussed

AppleCD SC \$1199
Apple Computer, Inc.
20525 Mariani Ave.
Cupertino, CA 95014
(408) 996-1010
Inquiry 1103.

Apple System 6.0.2
(Free from Apple dealers
if you bring your own disks)
Apple Computer, Inc.
20525 Mariani Ave.
Cupertino, CA 95014
(408) 996-1010
Inquiry 1102.

Colby WalkMac SE \$5449 and up
Colby Computers
4723 North Warren Ave.
Fresno, CA 93705
(209) 222-4985
Inquiry 1101.

Dynamac EL \$5895 and up
Dynamac Computer Products, Inc.
14001 East Iliff Ave., Suite 410
Aurora, CO 80014
(303) 233-7626
Inquiry 1106.

*Interactive Multimedia:
Visions of Multimedia
for Developers, Educators,
and Information Providers* \$24.95
Edited by Sueann Ambron and
Kristina Hooper. Redmond, WA:
Microsoft Press, 1988.
Inquiry 1104.

Wheels for the Mind
1-year subscription (4 issues) \$12
Peter Olivieri, editor
Apple Computer, Inc.
P.O. Box 1834
Escondido, CA 92025
Inquiry 1105.

bad (OK, so it still feels bad). I haven't used one yet, but I'm scheduled to get a review unit soon. I plan to lug it with me everywhere and use it for writing, editing, some site consulting, and teaching and speaking engagements, then report back to you in a couple of months. I can hardly wait. Maybe I'll be able to break my Zenith/Tandy/Toshiba habit yet.

A Bug-Free System and CD-ROM

I've had the debugged and released Apple 6.0.2 System software for a bit more than a month now, and it's a *huge* improvement over the buggy and unreliable System 6.0 release. Hopefully, the experience with 6.0 and the bug-fixing provided by 6.0.2 will help Apple's engineers get a clean version of System 7.0 out when it ships.

While I'm on the subject of Apple, let me talk about its CD-ROM drive, the AppleCD SC. I've had one of these things sitting around my office for a few months now, but didn't really have the chance to do much with it except hook it up and make sure it works (it does). The drive is a decent piece of work that plays CD audio disks in addition to reading CD-ROM data disks. It's pricey at \$1199, but it's often discounted. Since I'm teaching an introductory programming course (using HyperCard) for liberal arts students this quarter, it seemed logical to pull out the AppleCD SC and

fire it up with a copy of HyperCard 1.2 to try it as a read-only HyperCard storage device.

I've found that in and of itself, the AppleCD SC is not going to win any product-of-the-year awards for its technical execution. It's just a read-only device that happens to have a prodigious capacity (around 650 megabytes per disk). And it's generally slower than any Mac hard disk I've used. But technical prowess isn't what makes the AppleCD SC an important product. Nope, the AppleCD SC is important for what it can provide to applications like HyperCard: a nearly unlimited source of information that demands new methods of management and new paradigms for searching, sorting, categorizing, and displaying data.

This important point occurred to me as I was reading the excellent compilation of articles published in *Interactive Multimedia: Visions of Multimedia for Developers, Educators, and Information Providers*, edited by Sueann Ambron and Kristina Hooper and published by Microsoft Press. Many of those articles make it very clear that multimedia instruction, presentations, and data storage are no longer confined to research labs, but are being used and refined now in real environments, with Macs and CD-ROM drives being an important delivery platform.

continued

Discover Parallel Processing!



Monoputer/2™

*The World's Most Popular
Transputer Development System*

Since 1986, the MicroWay **Monoputer** has become the favorite transputer development system, with thousands in use worldwide. Monoputer/2 extends the original design from 2 to 16 megabytes and adds an enhanced DMA powered interface. The board can be used to develop code for transputer networks or can be linked with other Monoputers or Quadputers to build a transputer network. It can be powered by the 20 MHz T414 or T800 or the new 25 MHz T425 or T800.

Parallel Languages

Fortran and C Make Porting a Snap!

MicroWay stocks parallel languages from 3L, Logical Systems and Inmos. These include one Fortran, two Cs, Occam, Pascal, and our own Prolog. We also stock the NAG libraries for the T800 and Rockfield's structural and thermal finite element package. A single T800 node costs \$2,000, yet has the power of a \$10,000 386/1167 system. Isn't it time you considered porting your Fortran or C application to the transputer?

Quadputer™

*Mainframe Power
For Your PC!*

MicroWay's **Quadputer** is the most versatile multiple transputer board on the market today. Each processor can have 1, 4 or 8 megabytes of local memory. In addition, two or more Quadputers can be linked together with ribbon cables to build large systems. One MicroWay customer reduced an 8 hour mainframe analysis to 15 minutes with five Quadputers, giving him realtime control of his business.

For further information, please call MicroWay's Technical Support staff at (508) 746-7341.

Micro Way

World Leader in PC Numerics

P.O. Box 79, Kingston, MA 02364 USA (508) 746-7341
32 High St., Kingston-Upon-Thames, U.K., 01-541-5466
USA FAX 617-934-2414 Australia 02-439-8400 Germany 069-75-1428

One article in that compilation, written by Apple's Mike Liebhold, points out the artificial limitations placed on the use of CD-ROM technology. He argues that CD-ROM software that allows for only straight information search and retrieval is missing the boat by a wide margin. He makes the logical and technical case for serious decision-aid software based on CD-ROM technology.

Liebhold contends that optical disks should be more than an archival media; they must be linked to powerful software. Of course, that's now happening with respect to hypertext with Apple's own HyperCard 1.2, which supports the AppleCD SC drive. With HyperCard as the hypertext engine, you can create virtually any view or structure you need and pull into these new objects the information (sound, graphics, and text) that is stored on the CD-ROM disk.

You can start to explore the concepts of CD-ROM-based hypertext applications now with the AppleCD SC drive and the Apple Educational CD Sampler Disk (which is available free from many Apple district sales offices). This disk contains a number of HyperCard stacks and other

hypermedia programs and gives some pretty strong hints at the processing paradigms that are growing out of hypermedia research.

Wheels for the Mind

The best way to stay current on developments in multimedia and hypermedia uses for the Mac is through the Apple University Consortium journal called *Wheels for the Mind*. Edited by Boston College's Peter Olivieri, it is published quarterly and costs only \$12 for a 1-year subscription. In it, you'll find articles highlighting the Macintosh development projects planned or under way at major research schools and institutions. As an example, most of the topics covered in the summer 1988 issue had to do with HyperCard, in honor of its first birthday celebration.

The fall 1988 issue covered Mac applications used in instructional, research, professional, and administrative environments. Articles submitted for the publication often cover Macintosh applications and development efforts that you won't read about elsewhere.

In large part, some of the best software

for the Mac is in limited circulation within universities—software that you could take advantage of if you knew about it. *Wheels for the Mind* offers a good window into that software and its availability to non-university users. Much of the software (e.g., courseware, simulations systems, specialized research products, and extensions to popular commercial programs) that you'll read about in *Wheels* can be purchased for less than \$50 each from the Kinkos Academic Courseware Exchange Catalog. Stop in any Kinkos copy shop in your area and pick up a copy of the catalog (and get your name on the mailing list for future copies). I highly recommend it as a way to extend your use of the Mac. ■

Don Crabb is the director of laboratories and a senior lecturer for the computer science department at the University of Chicago. He is also a consulting editor for BYTE. He can be reached on BIX as "decrabb."

Your questions and comments are welcome. Write to: Editor, BYTE, One Phoenix Mill Lane, Peterborough, NH 03458.

Looking for an equation builder or multi-lingual editor for PageMaker or Ventura?

π | *thaw* | Ж

Vuwriter Link Pack provides the solution.

The Vuwriter Link Pack provides a fast multiple character set editor plus printer and screen fonts for HP and postscript printers. Systems are available for scientists, engineers, linguists, translators (20+ languages) and classicists.

Contact Vuman and find out how to add character to your Xerox-Ventura or Aldus PageMaker DTP System.

VUWRITER

Adding character to your D.T.P.

From Vuman Computer Systems Ltd Manchester

Tel: 061-226 8311

Worldwide Distribution

VCSL Inc Alabama U.S.A. Tel: 205 830 2620

ACT Informatique Paris France. Tel: 331 4633 7260

OREAD Computing Victoria Australia Tel: 61 3 783 9912

LANCO Computing Services Finland Tel: 358 18 525240



NO OTHER DESKTOP PUBLISHING SYSTEM OFFERS THIS FEATURE.

With the new Mannesmann Tally® Universal™ Publishing System, you can practically fly.

Thanks to a Raster Image Processor board that plugs directly into your PC or compatible, you'll process your pages at a speed limited only by the speed of your computer. Not—as is typical—at the speed of the printer. And you'll transfer ready-to-print data directly to the printer through a video interface at an incredible 3-million bits per second.

So when you're using the PostScript® compatible interpreter, you'll produce a printed page almost twice as fast as most other systems. But that's just ground speed.

If you use Aldus® Page-Maker or Ventura Publisher®, you'll

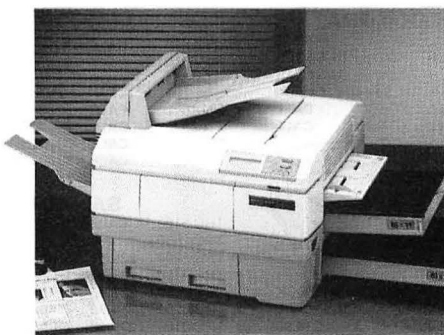

- Systems:
 1. Universal Publishing System (includes a PostScript compatible interpreter and Document Description Language (DDL))
 2. DDL Publishing System (DDL only).
- Resolution: 300 x 300 dpi.
- Emulations: Both systems include HP® LaserJet.
- Memory: 2 Mg.
- Typefaces: UPS includes 35 typefaces, DDL System includes 22 typefaces.
- Speed: 10 pages-per-minute.
- Dual paper cassettes standard, 250 sheets each.
- Dual output bins standard, 250 sheets each.
- Manual feed handles single sheets, envelopes, transparencies, and labels.
- Workload: 10,000 pages-per-month.

really take off. Because when you select DDL instead of the PostScript compatible interpreter, you'll double that speed again. And with full page bitmap graphics, you can get printed output up to 17 times as fast.

So call the number below for the name of your nearest dealer and log in your time on the New Mannesmann Tally Universal Publishing System. A pilot's license is not required.

**MANNESMANN
TALLY**

1-800-843-1347

Ext. 191

In Washington state, call:
206-251-5524 Ext. 191

Test results available upon request. PostScript is a registered trademark of Adobe Systems, Inc. DDL is a registered trademark of Imagen Corp. Ventura Publisher is a registered trademark of Ventura Corp. Pagemaker is a registered trademark of Aldus Corp.

NO ADDED CHARGE ON CREDIT CARDS



HOURS: Mon. Tru. Thurs. 9AM Till 6PM, Fri. 9AM Till 1:30PM, Sun. 9:30AM Till 5PM, Closed On Sat.

FOR COMPUTER & ACCESSORIES
CALL TOLL FREE: 1-800-882-2802
 FOR FAX, TYPEWRITERS & DICTATION EQUIPT.
CALL TOLL FREE: 1-800-223-7323
 IN N.Y. STATE CALL: 1-212-947-5290

LAPTOPS

TOSHIBA

SOLD IN STORE ONLY

T-1000



512K, 1-720K Disk Drive,
 Supertwist LCD Display,
 Weighs just 6.4 lbs.

CALL

TOSHIBA T-1200F.....	CALL
TOSHIBA T-1200FB.....	CALL
TOSHIBA T-1200HB.....	CALL
NEW! TOSHIBA T-3100E.....	CALL
TOSHIBA T-3200.....	CALL
TOSHIBA T-5100.....	CALL

ZENITH

ZENITH 184-1.....	1495.00
ZENITH 184-2.....	CALL
ZENITH Supersport 286 Model 20 w/20MB Hard Drive.....	3049.90
ZENITH 286 w/40MB Hard Drive.....	3449.00

DATAVUE

DATAVUE SPARK, 640K, 2-Drives, Backlit w/JT FAX Portable.....	1275.95
------------------------------------------------------------------	---------

NEC

NEC Multispeed HD.....	1959.00
------------------------	---------

LAPTOP ACCESSORIES

HOLMES 2400 Modem f/All Laptops.....	CALL
WORLD PORT 2400 Baud Modem.....	235.00
Diconix Portable Printer.....	304.90

DESKTOPS



DESKPRO 286, 12MHz, 1.2 Floppy Drive,
 Seagate 40MB Hard Drive (40ms).....**2065.00**
 NEW! COMPAQ 386/20E w/40MB Hard
 Drive.....**4749.00**
 NEW! COMPAQ SLT/286 Portable w/20MB
 Hard Drive.....**Low Price**



AST PREMIUM 286

10 MHz, 512K, 1.2 Floppy Drive,
 Seagate 40MB Hard Drive (40ms)
1719.90

NEW! AST 386C w/64K Cache Memory, 20
 MHz, 1MB Ram, 1.2 Floppy Drive, 40MB
 Hard Drive.....**CALL**

COMPATIBLES

IBM-XT Compatible, 1-360 Floppy Drive, 1-30MB Hard Drive.....	757.00
IBM-AT Compatible, 512K, 1.2 Floppy Drive, Seagate 40MB Hard Drive (40ms).....	1247.00

APPLE COMPUTERS.....CALL

PRINTERS

Panasonic



KX-P 1124

24 Pin, Narrow Carriage
 192 CPS Draft, 63 CPS NLQ,
 Tractor Feed Included

309.00

PANASONIC 1091i.....	174.95
NEW! PANASONIC 1181.....	CALL

EPSON

EPSON LX-800.....	179.00
EPSON LQ-500.....	CALL
EPSON LQ-850.....	529.00
EPSON LQ-1050.....	769.00
EPSON FX-850.....	349.95
EPSON FX-1050.....	499.95
EPSON LQ-2550.....	CALL

TOSHIBA (Sold In Store Only)

NEW! TOSHIBA Expresswriter 311.....	CALL
NEW! TOSHIBA 321SL Color.....	CALL
TOSHIBA 341SL.....	CALL
TOSHIBA 351 SX.....	CALL

NEC

NEC P5200.....	525.00
NEC P5300.....	687.00

PRINTER SALE!

H.P. Laserjet II w/Toner.....	CALL
H.P. Deskjet.....	CALL
STAR NX-1000.....	169.95
APPLE Imagewriter II.....	439.00

HARDWARE



Logitech Hi-Res Mouse.....	89.95
Logitech Clear Mouse.....	99.00
NEW! Logitech Scanman.....	CALL
PARADISE VGA Professional.....	CALL
NEW! PARADISE VGA Plus 16.....	299.90
NEW! Microsoft Mach 20.....	309.00
MICROSOFT Mouse.....	99.95
ZENITH Perfect Monitor.....	CALL
NEC Multisync Monitor.....	CALL
SONY 1302 Monitor.....	669.00
PLUS 20MB Card.....	CALL
TOSHIBA 3 1/2" Drive w/Kit.....	89.00
INTEL 80387-20 MHz.....	469.95

SOFTWARE

XY Write w/Al A Carte.....	215.95
ASK SAM.....	165.00
BITSTREAM Fonts.....	CALL
XEROX Ventura Publisher 2.0 Low Price.....	CALL
ORACLE f/LOTUS.....	119.95
NEW! Microsoft Flight Simulator.....	32.95
NEW! King Quest 4.....	29.00
PROCOM Plus.....	42.95
MICROSOFT Excel 2.1.....	299.95
FORMWORK w/Fill & File.....	79.00
PFS First Publisher.....	69.00
Mavis Beacon Teaches Typing.....	29.99
NOTA BENE 3.0.....	248.50
LUCID 3D.....	67.99
Q & A.....	189.00
INTUIT Quicken.....	31.95
MANAGING Your Money.....	115.95
TOBIAS PC/Tax Cut.....	CALL
DAC Easy Accounting 3.0.....	57.00
CHIPSOFT Turbo Tax.....	CALL
NOLO Will Maker.....	30.95
SPINRITE.....	48.99
Fastrax.....	CALL

FAX MACHINES

PANAFAX



UF-150.....	IN STOCK
UF-250.....	IN STOCK

SHARP

FO-220.....	CALL
FO-420.....	CALL
FO-700.....	1519.90
FO-800.....	2299.90

CANON FaxPhones

FaxPhone 8.....	599.90
FaxPhone 20.....	899.90
FaxPhone 25.....	1449.90
FAX 230.....	CALL
FAX350.....	CALL

RICOH

FAX-10E.....	CALL
FAX-20E.....	CALL
FAX-60E.....	CALL

MURATA

M-1200.....	629.90
M-1600.....	769.90

PANASONIC

KX-F 100.....	CALL
KX-F 120.....	CALL

TOSHIBA

3300.....	1039.90
3700.....	1329.90
Model 30100.....	959.90

SANYO

Model 515H.....	IN STOCK
-----------------	----------

BROTHER

FAX 60 w/Answering Machine.....	IN STOCK
---------------------------------	----------

FAX PAPER

8 1/2" x98".....	49.95
8 1/2" x164".....	59.90
8 1/2" x328".....	74.95
FAX Cleaning Kit.....	29.95

TYPEWRITERS & Word Processors



SMITH CORONA

PWP-60.....	469.90
PWP-40 IN STOCK.....	PWP-80 IN STOCK
NEW! PWP-100.....	IN STOCK
XL-1000 Typewriter.....	Special 129.90
XL-2500.....	CALL
XD-5500.....	CALL
XD-7500.....	CALL
XD-9500.....	CALL

PANASONIC



KX-W 1500 Word Processor.....	IN STOCK
KX-R 320.....	CALL
KX-R 330.....	CALL
KX-R 340.....	203.90
KX-R 350.....	236.90



BROTHER

WP-55 Word Processor.....	IN STOCK*
NEW! WP-490 "OPUS".....	CALL
AX-26.....	CALL
AX-28.....	CALL

*Free Spreadsheet Program w/Purchase of
 WP-55 Word Processor

Dictation Equipmt.



OLYMPIC PearlCorder

L-200.....	137.90
S-911.....	59.90
T-1010 Transcriber.....	169.90
S-804.....	CALL
T2000.....	CALL
S-907.....	35.90
S-930.....	99.90
S-810.....	CALL
T-2020.....	CALL

PANASONIC

RN-15.....	CALL
RN-89.....	CALL
RN-115.....	CALL
RR-900.....	CALL
RR-980.....	CALL
RN-36.....	CALL
RN-105.....	CALL
RN-125.....	CALL
RR-970.....	CALL

SANYO

TRC-6100.....	CALL
TRC-2550.....	149.90
TRC-5200.....	229.90
TRC-4100.....	227.90
TRC-8000A.....	227.90
TRC-8700.....	239.90
TRC-9100.....	239.90
TRC-5680.....	79.90
TRC-5020.....	179.90
TRC-4141.....	178.90
TRC-8010A.....	165.90
TRC-8070.....	185.90
TRC-9010.....	199.90

SONY

M-100B.....	CALL
M-750V.....	CALL
BM-12.....	CALL
BM-560.....	CALL
BM-75.....	CALL
BM-815T.....	CALL
M-740.....	CALL
TCM-5000EV.....	CALL
BM-17.....	CALL
BI-500.....	CALL
BM-80.....	CALL
BM-820.....	CALL

NORELCO

585.....	89.90
505.....	299.90
2505.....	259.90
510.....	374.90
MC-4000.....	349.90

COPIERS

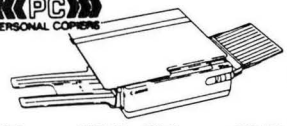

PC-3.....	345.90
PC-5L Legal Size.....	459.90
NEW! PC-6.....	709.90
NEW! PC-6RE.....	859.90
PC-7 Zoom Copier.....	919.90
Black Cartridges.....	79.95
8 1/2 x11 Paper (5000 sheets).....	49.50

**Special
 4 Black Cartridges
 299.90**

TELEPHONES

PANASONIC FEATURE PHONES

KX-T 2322 w/Automatic Dialing.....	30.90
KX-T 2335 w/28 station Dialer.....	32.90
KX-T 2342 w/Speakerphone.....	36.90
KX-T 2365 LCD w/Speakerphone.....	59.90

MULTI-LINE PHONES

KX-T 3122 w/3-Way Conference.....	56.90
KX-T 3142 w/Speakerphone.....	67.90
KX-T 3145 Speaker w/48 Station Dialer.....	71.90
CALL TX3170 3-Line.....	CALL

Answering Machines Specials

KX-T 1412.....	CALL
KX-T 1418.....	CALL
KX-T 1423.....	CALL
KX-T 1424.....	69.90
KX-T 1427 LCD w/Time Announce.....	96.90
KX-T 1622.....	CALL
KX-T 1720.....	CALL

CORDLESS PHONES

KX-T 3807 Cordless Phone.....	65.90
KX-T 3900 Cordless Telephone.....	124.90

VISA, MASTERCARD, AMERICAN EXPRESS, OPTIMA & DISCOVER CARDS ACCEPTED

OUR GUARANTEE: Defective goods will be replaced or repaired if returned within 10 Days in original packing, mint condition, blank warranty card, detailed letter of explanation & copy of invoice. No return privilege on software. If found defective, we will advise customer how to consult manufacturer for warranty service. For Customer Service: Please Call (212) 947-5295. Not Responsible for typographical errors. We reserve the right to limit quantities. TO ORDER by MAIL: Please send money order or certified check for UPS shipment on most items. Personal check delays your order by 15 days.

Shipping & Handling: Handling Charge; 2% plus 5.95. Shipping Charge; 0.65 per lb. Estimate minimum shipping 5.95. Total charge at time of order. Shipping & Handling charges are not refundable. INQUIRE about NEXT DAY AIR or 2nd DAY AIR Shipment. N.Y. State Residents add TAX.



MAIL ORDER: Dept BY, 120 West 31st Street, N.Y., N.Y. 10001 (Tel. 1-212-947-5290)
 MANHATTAN STORE: 120 West 31st. Street, N.Y., N.Y. 10001 (Tel. 1-212-564-3592)
 SCARSDALE, NY STORE: 455 Central Ave. (Scarsdale Plaza) SCARSDALE, N.Y. 10538 (Tel. 1-914-723-1331)
 N.Y.C. Consumer Affairs License Number: 800193

Circle 87 on Reader Service Card



ELECTING THE PM

Here's what you need to assemble an OS/2 workstation that runs Presentation Manager without breaking the bank

I have just spent days trying to assemble an OS/2 workstation to add to my local-area network. In this column and next month, I'll focus on the hardware you'll need to work with OS/2 version 1.1, the version with Presentation Manager. Version 1.1 is much pickier about the hardware that it runs on than version 1.0 was. This subject should be useful to those of you who already have an existing machine and are wondering whether or not OS/2 will run on it, and to those who are thinking about putting together a PM-capable machine.

It's not always a great idea to build a minimum acceptable system that runs OS/2, so I won't necessarily recommend the cheapest video board or disk controller. On the other hand, we can't all afford a Belchfire 950 33-MHz 80386. So I'll try to assemble the cheapest *reasonably powered* PM-based workstation. It won't be Mark's Dream Machine—just a machine that will get the job done.

Hardware

OS/2 requires the following:

- either an 80286- or 80386-based motherboard
- an OS/2-friendly BIOS
- an IBM PC AT-type hard disk controller
- a 1.2- or 1.44-megabyte floppy disk drive A that works without a device driver
- a 60-megabyte hard disk drive that works without a device driver,

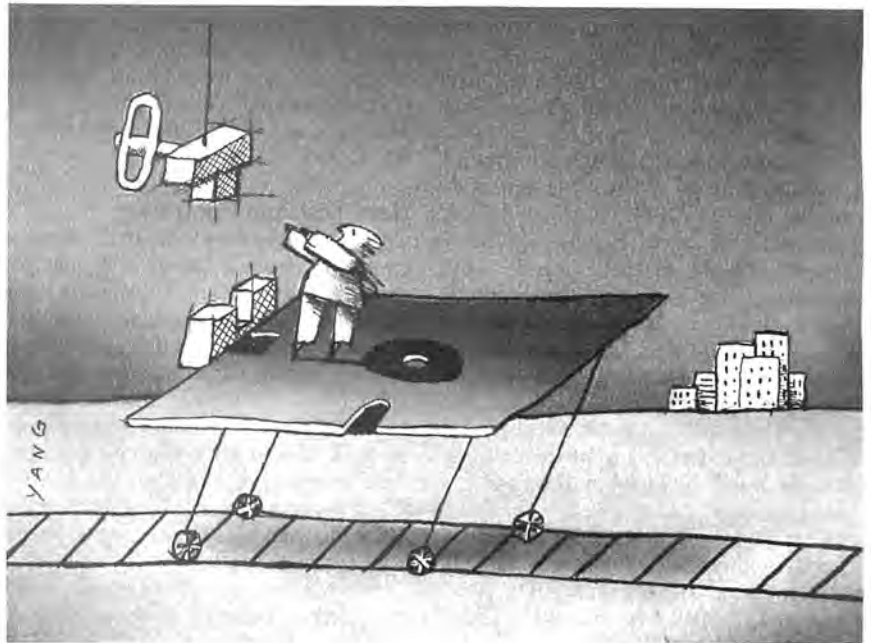

- with 32-megabyte or smaller partitions
- EGA or VGA graphics
- at least 2.6 megabytes of memory
- a mouse or other pointing device
- 16450-based serial ports

Wait! I see some of you shaking your heads, muttering, "Big, ugly, and slow. . . ." Don't leave yet! Consider that OS/2 is considerably more powerful than DOS, and it consequently needs a more powerful platform. I remember when people told me that Lotus 1-2-3 would never sell because it needed 512K bytes of memory to be really useful.

As anyone who reads this column knows, I'm no apologist for IBM or Microsoft. But OS/2's hardware requirements aren't necessarily a bad thing. OS/2 changes the meaning of "minimum configuration." Programs will have to be written to a new lowest common denominator, one that requires high-quality graphics.

Programs that use graphics effectively are now scarce in the IBM PC world, because developers have had to contend with the many monochrome boards and the incompatible Hercules/EGA/CGA "standards." An OS/2 application can assume that EGA graphics, *minimum*, will exist on any machine it runs on. So we'll see more and better graphical programs under OS/2 than we've seen under DOS.

An OS/2-Compatible Motherboard

OS/2 requires, as we all know by now, an 80286 or an 80386. Which to buy? I've discussed the overweening merits of the 80386 in the past. But we're trying to trim costs here, so I'll talk about an inexpensive 80286-based workstation.

One final word in favor of the 80386, though: Most 80386s nowadays (at least until the EISA [Extended Industry Standard Architecture] bus becomes a standard) differ from 80286s only in the

continued

motherboard and kind of memory—the rest of the add-in boards are identical. You'll buy the same 16-bit Ethernet card, VGA card, and so on. The difference between an 80286 and an 80386, pricewise, is just an initial \$700 to \$1000. I know, \$1000 isn't peanuts, but this workstation is going to run about \$5000 anyway, so another \$1000 for 80386 hardware and obsolescence-proofing wouldn't be a bad investment.

A basic 80286 AT-like motherboard—probably 10 MHz, no wait states, the low-end product these days—will work fine, as long as it has the right BIOS. The 80286 BIOS chips I've worked with are from IBM, Compaq, Phoenix, Award, DTK, and AMI. I'll eliminate those from IBM and Compaq for obvious cost reasons.

Of the remaining, I'd recommend either Phoenix or Award. I've had trouble running even OS/2 version 1.0 on some machines with AMI or DTK BIOSes. As late as early October—the last time I checked—one clone maker, Everex, told me that it couldn't run any version of OS/2 due to its AMI BIOS. The problem is due to be fixed—Everex will offer its own OS/2 soon—but the problem remains for garden-variety AMI BIOSes and most OS/2 implementations. Perhaps it will be fixed by the time you read this.

I've tried OS/2 on some DTK motherboards with DTK BIOSes without any luck. If you remove the DTK BIOS, however, and install a Phoenix BIOS, OS/2 will boot on many machines. Of course, if you have a machine that is compatible at the DOS level rather than at the BIOS or hardware level, you've got a fairly slim chance of getting anyone's OS/2 to run except that manufacturer's—if the company chooses to offer one.

One motherboard feature that would be particularly useful for running OS/2 would be a large memory capacity. We're starting to see motherboards that accommodate 4 or 8 megabytes of RAM. Be very careful here, however—memory is so expensive nowadays that the type of memory used in a computer is a major factor in determining the computer's overall cost. For example, looking at the prices this week (the end of October) for one large supplier, 1 megabyte of 100-nanosecond RAM would cost \$347 if purchased as 1-megabit dynamic RAMs, \$425 if purchased as a single in-line memory module, or \$495 if purchased as four banks of 256K-bit DRAMs.

Whatever memory system your computer uses, you need a lot of it. To simply boot the PM with the compatibility box

requires 2.6 megabytes, and you're best with a minimum of 4 megabytes. After all, why go to all the trouble to run OS/2 and end up with a few K bytes of free space? This way, you'll have a bit over 1 megabyte to work with.

What did I end up with? A 10-MHz, no-wait-state, no-name AT motherboard with 512K bytes on-board (expandable to 1 megabyte) and equipped with a Phoenix BIOS version 3.10. It came in a box with a power supply, an OMTI full-track-buffered AT controller, and a keyboard for \$720. Then I added an Everex RAM 3000 memory-expansion board and 3 megabytes in 256K-bit chips (I know I said that the 256K-bit DRAMs are the most expensive, but I already had the chips around). The board cost \$170, and the chips ran \$1500. Total so far: \$2390.

Hard Disk and Controller

OS/2 requires a hard disk drive. You can boot OS/2 from a floppy disk, but you can't fit all the basic OS/2 files on a single 1.2-megabyte floppy disk. So, even if you boot from a floppy disk, you have to operate from a hard disk. The PM, the OS/2 files, a few basic utilities, and an editor together take up 6.9 megabytes on my disk. That's not counting things like the C compiler; it's just the kind of things that a typical user will have as the basic OS/2 PM package. Hence, my 60-megabyte recommendation.

Believe me, my 60-megabyte Priam hard disk is bursting at the seams. As OS/2 is disk-intensive, you'd do well to acquire a fast hard disk drive. One suggestion is the Seagate ST4096, an 80-megabyte drive with an access time in the area of 30 milliseconds. Discounters are offering the ST4096 at this writing for just under \$600. Total cost so far: \$2990.

You can use just about any AT-type hard disk controller. The only kind of controller to avoid is an XT type. I know you wouldn't deliberately buy an XT controller for an AT, but if you have upgraded your XT to an AT with a "baby AT" motherboard, you may still be using your old XT controller. While outfitting a new OS/2 workstation, the basic AT-type Western Digital WD1003 controller should do just fine.

When formatting your 60-megabyte drive, you may be tempted to run On-track Computer Systems' Disk Manager, PC-DOS 4.0, Storage Dimensions' SpeedStor, or some other device driver that allows a logical drive to exceed 32 megabytes in size. *Don't do it.* OS/2 just plain doesn't know how to deal with logical drives larger than 32 megabytes. Just

run FDISK from OS/2 or DOS 3.3 to partition the disk to a logical C drive of 32 megabytes and a logical D drive of 28 megabytes.

Next stop: serial ports and video. You'd never believe it, but saving money on video was the hardest part. Can our hero build a PM-capable OS/2 workstation for less than \$5000? Tune in next month.

IBM OS/2 1.1 News

Just a day after the deadline for this column, I got a copy of IBM's OS/2 version 1.1. There's a lot of good news, and some bad news.

IBM's PM seems less machine-picky. I got it to run fine on some no-name 80286 and 80386 clones, whereas IBM's version 1.0 wouldn't run on the vast majority of the clones. And it *seems* fast—no benchmarks yet, though.

You can now restrict the amount of disk space that can be used for disk swapping. Previously, the swapper could eat up all your free space. Now you can say "leave me *x* megabytes free."

There will, indeed, be a CGA video driver for the PM. It will ship at the end of February.

It's *big*. IBM has squeezed the files onto five 1.44-megabyte floppy disks. A new UNPACK command unsqueezes them to about 14 megabytes—my earlier reference to 6.9 megabytes concerned the Microsoft Software Developer's Toolkit.

I haven't had enough time yet to find out whether or not this is some kind of copy-protection scheme, but *FORMAT /S does not work*. You get a message to the effect that "the /S option is not supported in this version of OS/2." I hope I've just overlooked something simple.

OS/2 Tip of the Month

Last month, I complained that there are no inexpensive OS/2 API (Application Program Interface) references. Two days after the galleys disappeared into the production process, I found *OS/2 API: The Pocket Reference* by Kris Jamsa (Osborne/McGraw-Hill, 1988). That's all it is—no OS/2 tips or tricks, just the unadorned API. But for \$5.95, what a deal! OS/2 programming just got cheaper. ■

Mark Minasi is a managing partner at Moulton, Minasi & Company, a Columbia, Maryland, firm specializing in technical seminars. He can be reached on BIX as "mjminasi."

Your questions and comments are welcome. Write to: Editor, BYTE, One Phoenix Mill Lane, Peterborough, NH 03458.

Two new DESQviews.

They're everything you want in windowing environments.

And less.

DESQview™ is the operating environment that brings OS/2™ power to DOS. And it lets you, with your trusty 8088, 8086, 80286, or 80386 PC, leap into the next generation in PC productivity. For not much money. And without throwing away your favorite software.

Introducing DESQview 2.2

And now, DESQview 2.2 adds capabilities, performance, and compatibility enhancements you've been asking for:

Like being able to fine tune DESQview performance "on the fly." Run Lotus Express and Metro. And the Intel Connection Co Processor. Even use the DOS 4.0 shell with DESQview. Have DESQview automatically install Quattro, Sprint, Aldus PageMaker, Microsoft Excel, Word Perfect, Dataease and as many as 80 other programs. And using the DESQview API, be able to dynamically link them.

More bang; less bytes

While other programs get bigger, we've worked to make DESQview smaller. And we've succeeded in a big way on PCs and PS/2™s with extended, EMS 3.2 (AboveBoard), EEMS and EMS 4.0 memory—as well as on 386 PCs and PS/2s. For example, DESQview overhead on EMS 4.0 and 386 PCs can be as low as 10K on EGA/VGA PCs. And

For programmers, DESQview's API, with its strengths in inter-task communications and multitasking, brings a quick and easy way to adapt to the future. With the API's mailboxes and shared programs, programmers are able to design programs running on DOS with capabilities like those of OS/2.



DESQview actually *increases* memory 30K on CGA PCs; 20K on monochrome and Hercules PCs. That's good news for users of big desktop publishing, CAD and database programs.

Introducing DESQview 386

For users of 80386 PCs and PS/2s (or PCs with 80386 add-in boards, such as the Intel Inboard 386), there's DESQview 386 (a combination of DESQview 2.2 and the new QEMM-386 Quarterdeck Expanded Memory Manager, version 4.2).

DESQview 386 gives you extraordinary power. Run text, CGA, EGA, VGA, and Hercules programs in windows and in the background. Run 32-bit 386 programs,

like Paradox 386, and IBM Interleaf simultaneously with your favorite DOS programs. All with the speed and performance you expect out of your 386. And with protection against 'misbehaved' programs.

Promise and performance

And, of course, both DESQviews have all the features that made prior versions the popular choice in operating environments. The ability to multi-task in 640K and beyond. View programs in windows or full screen.

Did you buy another environment that hasn't lived up to your expectations? Trade up to new DESQview. See coupon below.

Transfer data. Access DOS via menus. Dial your phone. And create keystroke macros within and between programs.

Our story gets better and better

If there's any doubt about our commitment to your PC and PS/2 productivity, just look at our accomplishments over the years. We think you will understand why PC Magazine gave



DESQview its Editor's Choice Award for "The Best Alternative to OS/2," why readers of InfoWorld twice voted DESQview "Product of the Year," why, by popular vote at Comdex Fall for two years in a row, DESQview was chosen "Best PC Environment" in PC Tech Journal's Systems Builder Contest. DESQview lets you have it all now.

DESQview System Requirements: IBM Personal Computer and 100% compatibles (with 8086, 8088, 80286, or 80386 processors) with monochrome or color display; IBM Personal System/2™ Memory: 640K recommended; for DESQview itself 0-145K* Expanded Memory (Optional): expanded memory boards compatible with the Intel AboveBoard™; enhanced expanded memory boards compatible with the AST RAMpage; EMS 4.0 expanded memory boards* Disk: two diskette drives or one diskette drive and a hard disk* Graphics Card (Optional): Hercules, IBM Color/Graphics (CGA), IBM Enhanced Graphics (EGA), IBM Personal System/2 Advanced Graphics (VGA)* Mouse (Optional): Mouse Systems, Microsoft and compatibles* Modem for Auto-Dialer (Optional): Hayes or compatible* Operating System: PC-DOS 2.0-4.0; MS-DOS 2.0-3.3* Software: Most PC-DOS and MS-DOS application programs; programs specific to Microsoft Windows 1.03-2.1, GEM 1.1-3.0, IBM TopView 1.1* Media: DESQview 2.0 is available on either 5-1/4" or 3-1/2" floppy diskette.

Trademarks are property of their respective holders: IBM, OS/2, PS/2, Lotus, Express, Metro, Quattro, Sprint, Aldus, PageMaker, Intel, Above Board, Hercules, Mouse Systems, Hayes, Microsoft, Windows, Excel, Word Perfect, Dataease, Paradox 386, Interleaf, TopView.

YES!
I need increased productivity now!

Payment Visa MasterCard

Expiration /

Account #

Name

Address

City State Zip

Qty	Product	5-1/4	3-1/2	Price Each	Totals
	DESQview 386 Multitasking windowing environment			\$189.90	
	DESQview 2.2 Multitasking windowing environment			\$129.95	
	DESQview 2.2 Upgrade from DESQview Version 2.0			\$24.95	
	Upgrade from DESQview 1.0 & AST Special Editions*			\$60.00	
	Upgrade from Topview, Windows, Visi-On, etc.**			\$65.00	
	QEMM-386 Version 4.2			\$59.95	
	QEMM-386 Version 4.2 Upgrade from QEMM 1.0-4.1*			\$19.95	
				Shipping & Handling	\$5 in USA / \$10 outside USA
					Calif Residents add 6.5%
					Grand Total

Quarterdeck

Quarterdeck Office Systems, 150 Pico Boulevard, Santa Monica, CA 90405 (213) 392-9851 Fax: (213) 399-3802

* Requires DESQview or QEMM-386 registration card on file at Quarterdeck or included with upgrade order; upgrades free to owners who show proof of purchase after August 1, 1988. Quarterdeck priority service users: 33% discount from upgrade price plus sales tax and shipping/handling.
** Just present proof of purchase of any multitasking operating environment—the cover of your manual will do—and send it to us along with the appropriate payment plus shipping, handling and tax.

What you've been doing.



*On your 286,
you've been making any task look complicated.*



*On your 386,
it hasn't been incredibly exciting having all that power.*

If the screens on the right look more intriguing to you than those on the left, you're ready for Microsoft® Windows.

Windows opens up the world of visual thinking to all 286 and 386 owners by offering the power of graphics.

Everything you can do on your PC, you can now do better, faster and with greater imagination. Whether you're creating documents or trying to get a clearer picture of your work.

What used to take complicated key-strokes can now be accomplished with the simple click of a mouse. With Microsoft Windows, you access pull-down menus. Simultaneously work with different programs as well as cut and paste between them to create graphic examples within different bodies of text. And what you see on the screen will appear on your printed page.

And once you've learned Microsoft Windows, you'll have the basis for scores of other programs because all the countless new Windows applications are based on the same easy, logical format.

Since Microsoft Windows virtually looks and works like MS® OS/2 Presentation Manager, you won't have to worry about it becoming obsolete in a couple years. We made both systems compatible. So, in the future, you'll be able to share

Stop playing with ancient instruments. Now cutting and pasting is a simple point and click with the Microsoft Mouse.

data between them. And your knowledge of Windows will give you a jump on learning MS OS/2 Presentation Manager.

You'd expect a program this powerful to require a more powerful machine. But we consistently create software that makes

©Copyright 1988, Microsoft Corporation. All rights reserved. Microsoft, the Microsoft logo and MS are registered trademarks, and Making it all make sense is a trademark of Microsoft Corporation. The following products have been used courtesy of their respective developers: Lotus and 1-2-3 by Lotus Development Corporation; WordPerfect by WordPerfect Corporation; PageMaker by Aldus

What you could have been doing.



With Windows/286,
you could have been seeing things much more clearly.

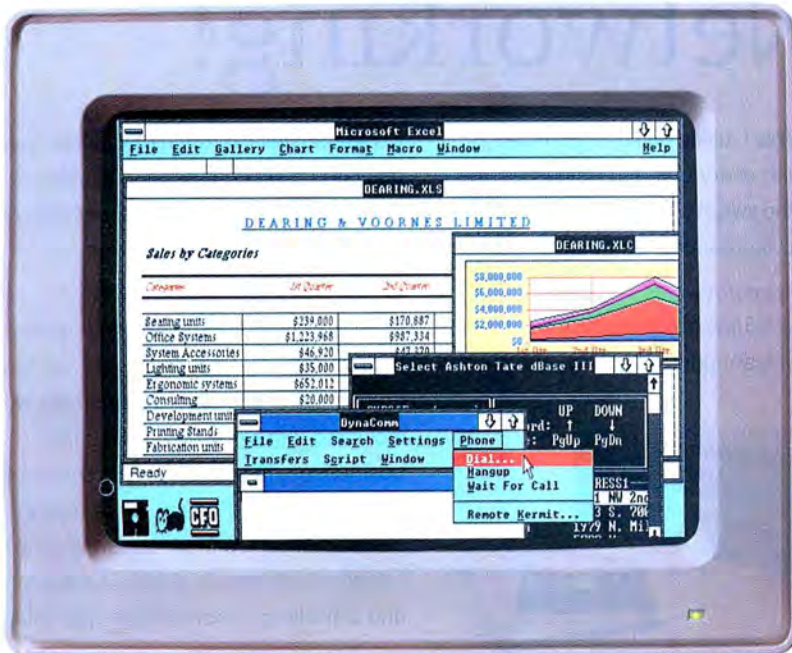

With Windows/386,
you could have been seeing a lot more things much more clearly.

the best use of your present hardware.

For example, Microsoft Windows/286 will work with as little as 640K and instantly make your machine more sensitive, intuitive and highly visual. It gives you the ability to run every Windows application available.



And with access to all those powerful programs, you'll be able to extend the life and usefulness of your 286 well beyond the introduction of MS OS/2 Presentation Manager. With version 2.1 you also get the benefit of increased speed. So you'll blaze through Windows applications up to 87% faster.

Microsoft Windows/386 will give you everything that Windows/286 gives you. Plus multitasking with most DOS applications. Now you can finally utilize the speed and power of any 386 machine.

Imagine creating a complicated spreadsheet. Then while a macro is being run, open up a word processor. Type a document, open and work with a graphics program. Cut and paste between programs and even call up electronic mail. And still be able to check on the status of your spreadsheet at any time.

Considering all you can do with Microsoft Windows, you have only one question to ask yourself.

What have you been doing without it?

Microsoft®



Our Printer Sharing Unit Does Networking!

An Integrated Solution

Take our **Master Switch™**, a sophisticated sharing device, combine it with **MasterNet™** networking software for PCs, and you've got an integrated solution for printer and plotter sharing, file transfer, electronic mail, and a lot more. Of course you can also share modems, minis, and mainframes or access the network remotely. Installation and operation is very simple.

Versatile

Or you can use the Master Switch to link any computer or peripheral with a serial or parallel interface. The switch accepts over 20 commands for controlling the flow of data. It may be operated automatically, by command, or with interactive menus. Its buffer is expandable to one megabyte and holds up to 64 simultaneous jobs. The

MasterLink™ utility diskette for PCs comes with every unit and unleashes the power of the switch with its memory-resident access to the commands and menus.

Other Products

We have a full line of connectivity solutions. If you just want printer sharing, we've got

it. We also have automatic switches, code-activated switches, buffers, converters, cables, protocol converters, multiplexers, line drivers, and other products.

Commitment to Excellence

At Rose Electronics, we're not satisfied until you're satisfied. That's why we have thousands of customers around the world including large, medium, and small businesses, factories, stores, educational institutions, and Federal, state, and local governments. We back our products with full technical support, a one-year warranty, and a thirty-day money-back guarantee.



**ROSE
ELECTRONICS**

**Call now for literature or
more information.
(800) 333-9343**

Give a Rose to your computer



THE ABCS OF X-, Y-, AND ZMODEM

XMODEM, the trailblazer among file-transfer protocols, has spawned a host of offspring

The dictionary definition of protocol is "proper and correct conduct." We encounter several instances of protocol every day, and we take most of them for granted. From navigating 2-plus tons of metal from a crowded freeway to an off-ramp or dealing with that surprise visit from the in-laws, some sort of protocol is called into play. Often, protocols are learned through years of experience, but sometimes they are simply a matter of law or social norm.

In the telecommunications arena, until the last few years, file-transfer protocol wasn't an issue. You had exactly two choices: straight ASCII transfers or XMODEM. At that time, there wasn't any confusion, but our limited choices played havoc with the dilemma of how to move large amounts of data over the phone lines.

Today, more than a dozen types of file-transfer protocols are wandering around the communications cosmos. The differences in efficiency among these protocols, and why each was originally developed, are often a matter of personal preference as much as they are a quest for a better mousetrap.

Ours is an age of specialization. Bearing that in mind, you shouldn't be surprised that file-transfer protocols are also specialized. No single protocol is the optimum choice in all circumstances.

XMODEM—Good Enough?

Ward Christensen wrote the original binary file-transfer program, which he

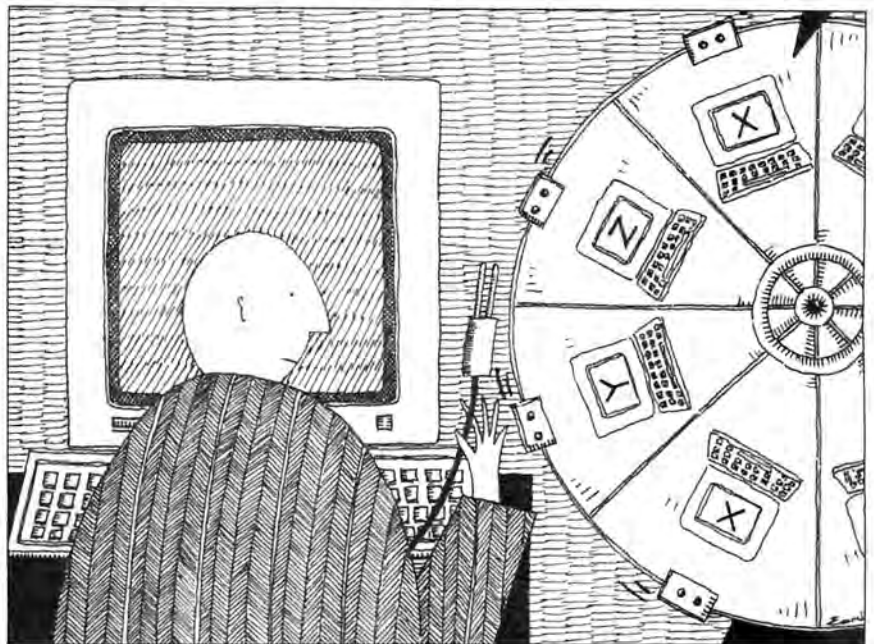

called MODEM. Keith Petersen adapted the program and called it XMODEM. The XMODEM protocol is a de facto file-transfer standard. But although it has achieved the status of a standard, it isn't internationally recognized as such. In an industry replete with standards, the fact that there's no official standard for file transfers seems incredible, but the telecommunications world seems filled with situations like this.

Because XMODEM is easy to implement, almost every communications package has its own version. Although these XMODEM implementations vary in how efficient they are, all but the most poorly implemented are compatible. It's rare to find two versions of XMODEM that can't complete a file transfer.

Simply speaking, XMODEM is a half-duplex protocol that transfers files in blocks of 128 bytes. *Half-duplex* means that only one computer can be "talking" at a time. Either the sender or the receiver is sending information to the

other; it's akin to a one-lane road that must handle two-way traffic. A *block* is merely a sequence of bytes grouped together and sent across the phone line as a unit. These blocks are sent in sequence, so a 1K-byte file requires the transfer of eight 128-byte blocks.

In the XMODEM protocol, the remote computer checks the integrity of each block of data. If the integrity of the block is intact, the remote sends the ACK (acknowledgment) signal to the local machine, which then sends another block. If the integrity check fails, the local computer receives a NAK (negative acknowledgment) and must send the block again.

The original XMODEM has several problems. The short block length, 128 bytes, causes throughput to suffer when used in conjunction with time-sharing devices, packet-switched networks, satellite circuits, and buffered (error-correcting) modems.

Also, XMODEM uses a simple one-

continued

character checksum for detecting errors. In this scheme, the protocol calculates a checksum (using the ASCII values of the characters in the block) and appends a byte, representing the value of the checksum, to the end of the block. The receiving system calculates the checksum of the block it received and compares that to the value of the checksum at the end of the block. If the values are the same, the block is considered intact and the next block is transferred. Noisy lines, however, can easily confuse and corrupt this checksum scheme.

To overcome the checksum scheme's susceptibility to noisy lines, a beefier error-checking scheme was developed—a 16-bit cyclic redundancy check. The addition of a 16-bit CRC using a two-character CRC-16, instead of the one-character arithmetic checksum used by the original XMODEM protocol, is known as the XMODEM/CRC protocol.

Another problem: The process of sending and receiving each block, and the ensuing error-checking done on each block sent, take a certain amount of time. This checking process is called *overhead*. In the original XMODEM

protocol, the ACK/NAK signals were sent after every 128-byte block. Now, though, the XMODEM protocol has been enhanced to allow the transfer of files in 1K-byte blocks. This improvement,

Despite
its shortcomings,
XMODEM continues
to be widely used.

called XMODEM-1K, means that fewer individual blocks need to be transferred and less overall time is needed for the ACK/NAK signals. This change has resulted in higher throughput and less time on-line.

XMODEM has other problems. You can transfer only one file at a time, the file transmitted can accumulate up to

127 extraneous bytes, and the modification date of the file is lost when it's transferred from one system to the other.

Despite its shortcomings, XMODEM continues to be widely used and widely accepted, and virtually everyone supports it for all kinds of communications. Indeed, there isn't a communications package around that doesn't claim some sort of XMODEM compatibility.

Christensen readily admits that his XMODEM protocol is "not robust" and that the only reason XMODEM is the accepted standard is because "it was released in August of 1977 and immediately dumped into the public domain." At the time, anything put into the public domain was seized on by hackers eager for any new challenges. And everyone thought he or she could do it better. Thus, XMODEM has had several evolutions, each independent of the other. The various adaptations of Christensen's original file-transfer protocol have led to a virtual Tower of protocol Babel.

YMODEM—Better Than X?

After XMODEM came YMODEM. This protocol addresses many of the shortfalls

How the competition stands

Introducing the modem with a sleek new stand-up* design. Telebit's new T1000 Multi-Speed modem. The modem that not only looks different, but is different. With more features. More performance. And a surprisingly low price.

More modem for less money.

What makes the T1000 so different? For one, you get a choice of more speeds. The T1000 can send and receive data at 300, 1200, 2400, or 9600 bps using ordinary dial-up phone lines.

So the T1000 can talk to your installed base of low-speed modems, plus the large installed base of Telebit® and other PEP™ high-speed modems.

But it costs about the same as a

2400 bps error-free modem.

Another difference? The T1000 runs at 9600 bps with any type of data—without compression. Error free. With MNP and PEP error detection and correction.

The T1000 fits right in.

The T1000 Multi-Speed modem even talks Hayes—right from the box. And if you're using the AT command set or even Smartcom III software, we're compatible. You won't need new software. And you won't need new commands.

The T1000 also has internal support for the most widely-used communications protocols—Kermit, Xmodem, Ymodem and UNIX's UUCP. So you can transfer files up to 3 times faster than any other modem.



of its forerunner. For starters, it transfers files in 1K-byte blocks and supports multiple file transfers, otherwise known as batch-file transfers. Veterans of the telecommunications world might wonder why we need a new batch-file protocol when the older CP/M-based MODEM7 protocol supported batch files. The answer is that MODEM7 didn't support full path names, file length, file date, or other attribute information to be transmitted.

YMODEM, like XMODEM, is a half-duplex protocol. To further overcome the limitations of the half-duplex modem, YMODEM-g was developed. The "g" option of YMODEM is a modification of the YMODEM in which ACKs for data blocks aren't used. The data is merely sent all at once. The protocol doesn't use the ACK/NAK turnaround that XMODEM uses.

The receiver initiates the g option. When the sending computer recognizes this option, it knows to bypass the usual wait for an ACK to each transmitted block, sending all blocks in sequence and at full speed. The protocol, however, is subject to XON/XOFF flow con-

trols (stop and go signals imposed by packet-switched networks).

YMODEM-g is intended to take advantage of high-speed, error-correcting modems. That's because error correc-

Z MODEM

*is an attempt
to correct the defects in
X- and YMODEM.*

tion is taken care of at another level—between the hardware of the two systems. Theoretically, then, the software doesn't have to worry about things like ACK signals. The bottom line with YMODEM-g is that it doesn't support error recovery. If a NAK is received, the file transfer aborts. For this reason, you should use YMODEM-g only in a hard-wired envi-

ronment or with a session-level protocol that takes care of error correction.

ZMODEM—Best of the Bunch?

The author of YMODEM and ZMODEM is Chuck Forsberg. ZMODEM is an attempt to correct the defects in the previous versions of X- and YMODEM. The development of the ZMODEM protocol was funded by Telenet in an effort to improve a file-transfer protocol used with packet-switched networks. ZMODEM is an end-to-end protocol that uses a technique called *streaming*.

With streaming, the sender doesn't expect to get any ACK signals back from the receiver until the transfer is complete. If an error occurs, the sender will receive a NAK, and it's up to the sender to ensure that it can recover from any NAK received. This technique is advantageous when you're using a packet-switched network where the session-level protocols that are exerted by the network add more delays for file-transfer turnaround.

ZMODEM is extremely robust because of the error-correction scheme de-

continued

up to Telebit's newest modem.

And here's another big difference. Since the T1000 runs the most popular communications software at the highest possible speeds. You can take full advantage of packages like HyperACCESS, Crosstalk-Fast, MicroPhone II, and Acknowledge.

Just plug us in, and the T1000 will fit right in. No matter what your environment.

Remote management for ease of use.

Here's the final difference. The T1000 offers a host of remote management features. Including remote access, remote configuration and remote diagnostics.

So get the modem that's head and shoulders above the rest. In features and performance. At just the right price. Telebit's new

T1000 Multi-Speed Modem.

Call 1-800-TELEBIT or (415) 969-3800, today.

Or write Telebit at
1345 Shorebird Way, Mountain View, CA 94043-1329.

Fax: (415) 969-8888.

Because no one gets the message through like Telebit.

T1000.



© 1988 Telebit Corporation. Telebit is a registered trademark and PEI is a trademark of Telebit Corporation. Other brands or product names are trademarks of their respective holders.

*optional

Circle 228 on Reader Service Card



HOW DO YOU GET A JOB WITHOUT EXPERIENCE? AND HOW DO YOU GET EXPERIENCE WITHOUT A JOB?

Most young people have one answer to this problem. They avoid it until they're out of college. But they could be getting solid work experience while they're still in college. With your company's help. And ours.

We're Co-op Education. A nationwide program that helps college students get real jobs for real pay, while they're getting an education.

But we can't do it without you. Those real jobs have to come from real companies. Like yours.

For more information on how you can participate in this valuable program, write Co-op Education, Box 775E, Boston, MA 02115.

Not only will you be giving students a chance to earn money and pick up the most valuable kind of knowledge, you'll be giving yourselves a chance to pick up the most valuable kind of employee.

Co-op Education.

You earn a future when you earn a degree.



A Public Service of This Publication ©1987 National Commission for Cooperative Education

veloped by Forsberg; all ZMODEM transactions are protected with 16- or 32-bit CRC. According to Forsberg, when it is properly used, the 32-bit CRC reduces undetected errors by at least 5 orders of magnitude. ZMODEM also has a special security-challenge mechanism that guards against "Trojan Horse" messages written to mimic legitimate commands or file downloads.

Other advanced features include the ability of the sending or receiving computer to trigger an automatic download or command sequence; automatic step-down to YMODEM if the other end does not support ZMODEM (this ability, of course, assumes that the transmission medium accommodates both XMODEM and YMODEM); ease of implementation via a shell to an external program (DSZ.EXE); and file transfers that begin immediately, regardless of which program is started first, without the 10-second delay associated with XMODEM file transfers.

On the Horizon

Is there any rule of thumb you can follow concerning what protocol will best fill your needs? Sure. Try out several of them, and use what works best for you. In today's environment, that usually means XMODEM. After all is said and done, it's really the basic "standard." And assuming your communications package supports such protocols, you can improve your file transfers by using the more advanced X-/YMODEM-1K protocols.

We now have a wide variety of file-transfer protocols to choose from. And until the industry comes up with an official standard, you may find that the intelligent way to go is to use a combination of several different protocols. How do you know which protocol is the best to use in any given situation?

Next month, I will address this issue and explore the effect of high-speed modems, with their built-in error-correction schemes, on these various protocols. I'll compare each of these protocols when they are used over normal voice-grade telephone lines and with packet-switched networks. The results are mixed and, in some cases, surprising. ■

Brock N. Meeks is a San Francisco-based freelance writer who specializes in high technology. You can reach him on BIX as "brock."

Your questions and comments are welcome. Write to: Editor, BYTE, One Phoenix Mill Lane, Peterborough, NH 03458.

Are you tired of seeing **RED?**

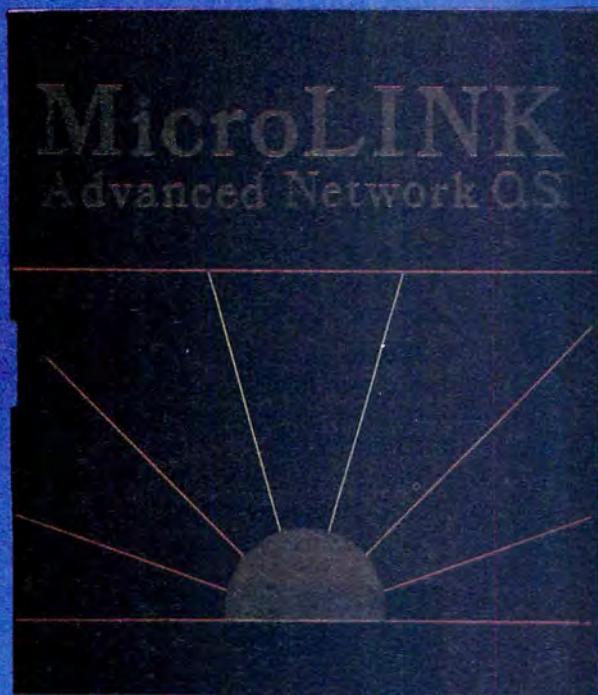

If you are developing a network application for the PC or PS/2, you should consider **MicroLINK Network Developer's Kit**.

MicroLINK Network Developer's Kit will give you a complete SMB protocol redirector, server and memory management for use on any standard NETBIOS.

Very High Performance

MicroLINK is a very high performance network operating system. In most environments it is 75% faster than the so-called industry leader.

Easy to Implement

MicroLINK comes as stand alone software modules. **MicroLINK** can be interfaced through MSC or MASM calls.

Low Memory Requirements

MicroLINK requires less than 40k bytes for a user, or 64k bytes for a nondedicated server. **MicroLINK** can also use EMS memory for even lower memory requirements.

Four Nodes Complete

MicroLINK Network Developer's Kit gives you four (4) nodes to develop your applications on. You can easily purchase additional nodes as you need them. You will also receive NETBIOS interfaces for WD8003E and WD8003ET/A ethernet adapters and others. Complete developer's documentation is included which outlines all network programming interfaces.

For network developing without the headache, **MicroLINK Network Developer's Kit**

Available at Programmer's Shop, Programmer's Connection and Programmer's Paradise

Simple NET Systems, Inc. • 545 West Lambert Road • Suite A • Brea, California 92621

(800) 262-8010 • IN CALIFORNIA (714) 529-8850 • FAX (714) 529-2413

MicroLINK is a registered trademark of BCSoft Corp. Other brand and product names are trademarks of their respective holders.

DAZZLING PERFORMANCE.



'286/SS

COMPLETE 12MHz '286 WITH 32MB HARD DRIVE ONLY \$1295.00

- 80286 CPU, 6/12 MHz Dual Speed, Keyboard Selectable.
- Zero-Wait State RAM, 512K expandable to 4MB on the motherboard (16MB System Total).
- 32MB Hard Drive, 1.2MB Floppy Drive.
- Ultra high speed Hard/Floppy controller. 1:1 interleave, 800 KB/sec transfer rate.
- High Res 12" Amber Display with Tilt and Swivel Base. Compatible graphics controller.
- ZEOS Enhanced Keyboard, Pleasant Tactile/Click Feel.
- Serial and Parallel Printer Ports.
- Clock/Calendar with Battery Backup.
- 6-16 and 2-8 bit expansion slots.
- 80287 support, up to 12 MHz.
- Space Saver Case with Security Lock, LED indicators.

12MHz, 16MHz and 20MHz '286 HARD DRIVE SYSTEMS

As high as 20MHz! Dazzling performance is yours with one of these high performance full size ZEOS '286 Systems.

Each comes *complete* with our standard features including drives, monitor, high speed controller, etc. Our full size case features room for up to 5 half-high drives, two of which are internal. Incredible values.

■ **286/12**—Complete 12 MHz System with 512K of Zero-Wait RAM, High Speed 32MB Hard Drive and all the standard ZEOS goodies. **ONLY \$1395.00**

■ **286/16**—Complete 16MHz system with 1MB RAM on board and High Speed 32MB Hard Drive. *Faster than a '386 16MHz* when running 16-bit software! **ONLY \$1895.00**

■ **286/20**—At 20MHz, it's the fastest. Complete with our 32 MB, High Speed Hard Drive and 1MB RAM. This is what Dazzling Speed is all about. **ONLY \$2095.00**



'286/FS

DAZZLING PERFORMANCE. INCREDIBLE PRICES.

Can you believe it? *Yes, you can!*

We've proven it to thousands and we would like to prove it to you. ZEOS® systems are sold *complete*, ready to plug in and fly right out of the box. And the quality

and prices are incredible.

How is it possible? Because your ZEOS computer comes to you *factory direct*, fully assembled, burned-in and tested in our own laboratories. Every system is built to order. Custom built actually, right to your own specifications.

And our quality and performance are second to none.

We don't just say it. We guarantee it. That's why your new ZEOS system comes with a Full One Year Limited Warranty and our 30 day Full Refund Satisfaction Guarantee.

So pick out your dream

INCREDIBLE PRICES.



'386/SS

**COMPLETE 16MHz '386 DESKTOP
WITH 32MB HARD DRIVE.**

ONLY \$2495.00
(20MHz add \$500)

- Genuine 32-bit Intel 80386, 16 or 20MHz parts.
- 1MB of RAM Expandable to 16MB.
- 32MB, High Speed Hard Drive, 1.2MB floppy drive.
- Ultra high speed Hard/Floppy controller. 1:1 interleave, 800 KB/sec transfer rate!
- High Res 12" Amber Display with Tilt and Swivel Base. Compatible graphics controller.
- 101 Key ZEOS Tactile Click keyboard.
- Serial and Parallel/Printer Ports.
- Clock/Calendar with Battery Backup.
- 2-32, 4-16 and 2-8 bit slots.
- 80287 and 80387 support.

**COMPLETE '386 VERTICAL SYSTEM.
64MB DRIVE!**

ONLY \$2995.00
(20MHz add \$500)

Acknowledged worldwide as the highest performance value anywhere. Same great standard ZEOS features found on our other complete systems plus:

- 64KB Zero-Wait CACHE using 64K of SRAM.
- 1MB of 32-bit RAM system expandable up to 16MB.
- 65MB High Speed Seagate Hard Drive.
- 80287 and 80387 optional.
- Heavy Duty Vertical Case.

Call about our new 25MHz systems. Now Shipping!



'386/V

machine and order it now with confidence. Dazzling performance and incredible prices await you. *Guaranteed.* Order now by calling 800-423-5891.

Other ZEOS Options Include:

- Basic Configurations: Call for prices on systems

without drives, etc.

- EGA/VGA Upgrades. 14" EGA color monitor with EGA card, add \$495. 14" VGA system, add only \$695

- High Capacity Drives. Many other drives and options are available. Call Toll Free for details, 800-423-5891

**ORDER NOW TOLL FREE
800-423-5891**

FAX Orders Dial: 612-633-2310

In Minnesota Call: 612-633-4591

530 5th Ave. NW, St. Paul, MN 55112

Open days, evenings and weekends.

MasterCard, VISA and C.O.D.

Se habla Español.

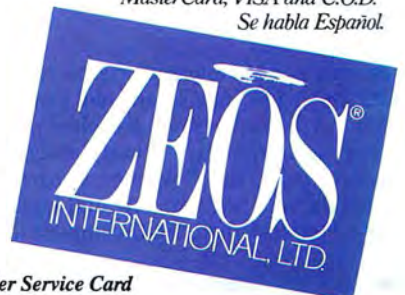



Smoothing Out C

Optimizing C compilers combine speed, high-level convenience and low-level power

Steve Apiki
and Jon Udell

Compilers have long been available for DOS, but sophisticated optimization and integrated environments are recent developments. Optimization techniques, especially, have brought new power to C. Handcrafted assembly language code still outdoes even the best machine-generated code, but optimizers are rapidly improving, and as a result programmers can rely more on C and less on assembly language.

This month, we focus on a narrow subset of C compilers for DOS—those with highly developed optimization capabilities. We looked at six packages: Turbo, Aztec, MetaWare, Microsoft, Watcom, and Zortech. Table 1 lists basic features.

All six compilers are more or less compatible with the developing ANSI standard (see table 2), and all include library support for standard functions. We evaluated each compiler with a benchmark suite consisting of tests developed by BYTE's editors and by C experts.

C Background

C is a high-level language originally defined by Brian Kernighan and Dennis Ritchie in the early 1970s. Its cult of popularity began during C's early association with Unix. But C went on to earn a reputation based on two essential qualities: portability (there's a C compiler for

nearly every computer) and versatility.

Because C's fundamental data types map closely to underlying machine types, C has been called the universal assembly language. That makes it a good language in which to implement, for example, a code generator. Yet because the rules by which you combine fundamental C data types into more complex types are regular and systematic, C also works well at high levels of abstraction. So it's an equally good language in which to implement a database package or a windowing system.

The proliferation of C, which Kernighan and Ritchie only informally specified, inevitably began to cause problems. Compiler writers diverged in their interpretations of the language, and they created incompatible dialects. More recently, there's been a movement to standardize the language around a set of guidelines being developed by an ANSI committee (see the text box "An ANSI Conformance Sampler" by Thomas Plum on page 176).

All the compilers we tested conformed well to the unofficial standard. We ran thousands of lines of code through each compiler with virtually no problems. Using compilers available just 3 or 4 years ago, however, our results probably would have been different.

Optimization Techniques

Compiler optimizations fall into two broad categories: source level and object level. Source-level optimizations operate independently of the target processor; object-level optimizations seek to exploit the characteristics of the target machine.

Hoisting of loop-invariant code is one classic source-level optimization. Here, the optimizer detects that an operation within a loop—say, an assignment—does not affect and is unaffected by the other operations in the loop, and so hoists the loop-invariant statement out of the loop. The assignment happens once (not many times), and the resulting code runs

faster. Other source-level optimizations include elimination of dead code, elimination of unnecessary copies, constant folding, and elimination of common sub-expressions.

A section of code is dead if there's no way for it to execute—a statement within an `if(0){...}` block, for example. An optimizer can simply discard such a statement. Unnecessary copies occur when a variable that's assigned a value isn't used; again, an optimizer can discard the futile assignment.

When the value of an arithmetic expression is constant and can be determined directly or indirectly by inspection of the source code, an optimizer can fold the constant into the code in place of the expression and thus shift the burden of computation from run time to compile time. When the same expression occurs twice in a region of code, an optimizer can replace that common subexpression with a temporary variable.

Object-level optimizations complete an optimizing compiler's repertoire. Intelligent use of the available set of instructions and addressing modes represents one form of object-level optimization.

The 80x86 architecture, for example, offers particularly effective instructions for moving and comparing bytes; compilers targeted to that architecture should use those instructions. Efficient use of registers for the storage of variables is one of the most powerful optimization techniques. Good register allocation is a science. Register allocators often use a so-called graph-coloring algorithm to map the variables active within a section of code to available registers and to make optimal selections based on the amount of use each variable receives.

We tested the six C compilers for both source optimization and object optimization. But our tests also explored two other areas: low-level performance and application performance (XLisp). To de-

continued



PRODUCT FOCUS
OPTIMIZING C COMPILERS

Table 1: A summary of each compiler's features reveals differences that can enhance performance (● = yes; ○ = no).

	Borland Turbo C Professional 2.0	Manx Aztec C86 Commercial 4.1d	MetaWare High C 286 1.4	Microsoft C 5.1	Watcom C 6.5	Zortech C 1.07
Price	\$250	\$499	\$595	\$450	\$495	\$89.95
General						
Single compile/link command	●	●	○	●	●	●
Linker	●	●	○	●	●	●
Librarian	●	●	○	●	●	●
Stand-alone assembler	●	●	○	●	○	○
Make utility	●	●	○	●	●	●
Source code debugger	●	●	○	●	●	○
Editor	●	●	○	●	●	●
Integrated environment	●	○	○	●	●	● ¹
Memory models						
Tiny (64K total)	●	○	○	○ ²	●	●
Small (64K code, 64K data)	●	●	●	●	●	●
Medium (1M code, 64K data)	●	●	●	●	●	●
Compact (64K code, 1M data)	●	●	●	●	●	●
Large (1M code, 1M data)	●	●	●	●	●	●
Huge (large, but single data > 64K) ³	●	○	●	●	●	○
Library						
DOS interrupts	●	●	● ⁴	●	●	●
Dual executables (80x87 emulator)	●	●	●	●	●	●
Graphics library	●	●	○	●	●	●
Language extensions						
Pascal vs. C calling conventions	●	○	●	●	●	○
In-line assembler code	●	●	○	○	●	○
Assembler, linker						
Real-mode 80386 instructions	○	○	●	○	○	○
Interface to assembler code	●	●	●	●	●	●
Interface to other HLL	●	○	●	●	●	○
ROMable code	○	●	●	●	●	●
Other						
On-line help	●	○	○	●	●	●
Wild-card file specs to compile, link	●	○	○	●	●	●
Response file to compile, link	●	○	○	●	●	●
Install program	●	○	●	●	●	●
Documentation (pages)	2269	708	430	2518	1391	582
System requirements						
Operating system	DOS 2.0	DOS 2.0	DOS 2.0	MS OS/2 1.0 or DOS 2.1	DOS 2.0	DOS 2.0
RAM	448K	384K	384K	448K	512K	512K
Drives	Two floppy or hard disk	Two floppy or hard disk	Hard disk	Hard disk, 1.2M floppy ⁵	Two floppy or hard disk	Two floppy or hard disk
Format	3½" or 5¼"	3½" or 5¼"	5¼"	3½" or 5¼"	3½" or 5¼"	3½" or 5¼" ⁶

¹ Editor/compiler only.

² Memory models can be customized.

³ Static data can exceed 64K in any model (huge keyword).

⁴ No bios function, but interrupts handled in library.

⁵ High density required for OS/2 functions only.

⁶ \$20 additional charge for 3½" version.

termine the effectiveness of the math libraries, we ran the suite twice: once on a Compaq 386 portable with an 80387 floating-point unit (FPU), and once on a Northgate 386 with no coprocessor. All tests were run using the small memory model. Starting with the low-level benchmarks, each test is detailed below, and the results are found in table 3.

The Low-Level Tests

For our low-level tests, we used six C functions devised by Thomas Plum. Each function contains an inner loop that executes exactly 1000 operations, and the test names reflect the types of operations they perform: integer arithmetic, floating-point arithmetic, function calling, and so on. These tests, which Plum Hall freely distributes, report the time—in microseconds—required for a single operation of a given type.

On our coprocessor-equipped Compaq 386, for example, the results show that an empty function call takes about 1.5 microseconds. That number was relatively invariant from compiler to compiler: The fastest was Watcom at 1.43 μ s, the slowest was Aztec at 1.55 μ s.

In general, the compilers bunched closely on the low-level tests, but the floating-point test yielded more diversity. Zortech, which took second on the emulator version of the test, finished last on the coprocessor version. The moral: Test both floating-point libraries that your compiler provides.

The XLisp Tests

For the XLisp tests, we used each compiler to build six working XLisp interpreters. Then we used each interpreter to run some benchmark programs. XLisp, written by David Betz, is a freely distributed program. Comprising 23 source files and 24,000 lines of C source code, XLisp is representative of the large, complex applications that serious C programmers construct to solve real problems.

Our low-level benchmarks rate the code generated by compilers according to specific measures of performance. They answer questions like: How efficient are function calls, integer multiplications, string comparisons, and pointer operations? How fast are the emulator and coprocessor library routines? How effective is the optimizer?

Our application in this case is the XLisp interpreter; its performance on a suite of Lisp benchmarks we wrote especially for this purpose constitutes our high-level compiler benchmark. The XLisp tests answer a more general—and probably more interesting—question:

When you write a program that uses all these features, how big will it be and how fast will it run?

Building XLisp

We knew that using six compilers to build six interpreters would be a big project. It was, but it turned out to be less difficult than we thought, for two reasons. First, XLisp is a cleanly written and beautifully modular program. Second, all the compilers support most of the important proposed ANSI standard features, so we had virtually no problems.

There was just a single glitch. All these compilers, except MetaWare's, support the library function `bdos`, which enables C programs to use DOS INT21 functions. The IBM PC version of XLisp uses `bdos` for a handful of primitive I/O routines. It's not part of the ANSI standard, but it's a convenience that many IBM PC compilers provide.

MetaWare does provide an alternative: You include an MS-DOS interface file and can then use a function called `call_dos` in conjunction with a structure called `Registers`. It's slightly less convenient than `bdos`. You have to load `Registers` with appropriate values, call `call_dos`, then retrieve the result from `Registers`. But after a bit of experimentation, we got it to work.

XLisp makes just three calls to `bdos`, and they're encapsulated in a single file. We added alternate versions of the three XLisp functions (embedded in a conditional `#IFDEF METAWARE...#ENDIF` block) and added `-DEF METAWARE` (to activate that block) to the command line we used when building XLisp with the MetaWare compiler. That solved the problem. It wasn't pretty, but given the scope of the project, we were pleasantly surprised to find that, for six compilers, one conditional block was the only modification that we had to make.

Lisp Benchmark Programs

We wrote six Lisp benchmark programs. The floating-point test executes 50,000 floating-point multiplications in a tight loop. The two sort tests share a common Lisp routine that implements an exchange sort; the routine operates on a list of objects and returns a sorted list. The integer sort operates on a randomly generated list of 500 integers, and the float sort operates on a randomly generated list of floats. The file I/O tests read and write a 32K-byte file.

We built the lists once, stored them in files, and used Lisp functions to read the numbers and construct the lists, thus ensuring that each interpreter would per-

form the same sequence of actions. We didn't time the helper functions. The numbers shown reflect only the time required for the sort.

Like the sort test, the sieve test executes a complex algorithm—in this case, the classic prime-number sifter. But its central data structure is an array—just as in the C version of the sieve—rather than a Lisp list. Lisp's hallmark, list manipulation, relies on techniques and data structures that aren't typical of many applications. To exercise a different (and possibly more representative) kind of functionality, we stored the flags that the sieve uses in a Lisp array—an object that's implemented in a relatively straightforward manner in terms of an ordinary C array.

Finally, the function-call test mimics its counterpart in the low-level suite. Here, we repeatedly executed an empty function call.

Results

The results show an interesting diversity. Watcom won the floating-point test. That makes sense, since it won the corresponding test in the low-level suite. Turbo, Aztec, and MetaWare did poorly on the floating-point test, and that too correlates with their performance on the low-level tests. Watcom took another first on the sort tests, followed by Microsoft. Zortech came in last on the sort; that's a bit surprising in view of its relatively strong overall performance on the low-level tests, and it proves that low-level tests taken alone can be misleading.

By way of redemption, though, Zortech dominated the file I/O tests, followed by Microsoft and Watcom, with MetaWare last. The winner of the Sieve test was Microsoft, with Turbo a close second. And Watcom did poorly on the Sieve—an unexpected result given its otherwise stellar performance. Watcom and Microsoft took first and second on the Function-Call test—results that again correlate with the low-level tests.

The combined results show Watcom and Microsoft as the favorites, as was true in the low-level tests. But Watcom, which trounced Microsoft on the low-level tests, won the XLisp tests by only a slim margin. That trend was apparent across the board—in contrast to the low-level tests, on the XLisp tests, times varied less from one compiler to another. The slowest interpreter, compiled by Aztec, trailed the fastest, compiled by Watcom, by 30 percent on the low-level index, but by only 20 percent on the XLisp

continued

Table 2: *The results of the Plum Hall ANSI validation suite. The tests represent requirements of the X3J11 standard.*

Draft reference	Description	Turbo C 2.0	Aztec C 4.1d	MetaWare C 1.4	Microsoft C 5.1	Watcom C 6.5	Zortech C 1.07
2.1.1.2	Backslash-splicing	○	●	●	○	●	○
2.1.1.2	Phases of translation	○	○	○	○	○	○
2.2.1.1	Trigraphs	○	○	○	○	●	○
2.2.4.2	<float.h>: DBL_DIG >= 10 ¹	●	●	○	○	●	●
2.2.4.2	<limits.h>: has MB_LEN_MAX ²	○	○	○	○	○	○
3.1.2	Internal identifier significance at least 31 characters	●	○	●	○	●	●
3.1.2.2	Scope rules: file, function, prototype, and block	●	●	●	●	●	●
3.1.2.3	Name space rules: variables, labels, tags, and members	●	●	●	●	●	●
3.1.2.3	Unique member name spaces	●	●	●	●	●	●
3.1.2.5	long double (even if same size as double)	●	●	●	●	●	○
3.1.2.5	All unsigned types	●	●	●	●	●	●
3.1.2.5	signed char	●	●	●	●	●	●
3.1.2.6	Type-compatibility rules ²	●	●	○	●	●	○
3.1.3.2	Constants: U, L, unsignedness rules	●	●	●	●	●	●
3.1.3.4	Character constants with more than one char	○	○	○	○	●	●
3.1.3.4	'\xFF'	●	/	●	●	●	/
3.1.3.4	'\a' '\v'	●	/	●	●	●	●
3.1.3.4	Wide characters: L'x', L"x", wc*, mb*, wchar_t ²	○	○	○	○	○	○
3.1.5	"Old-style" assignment operators are gone	●	●	●	●	●	●
3.2.1.1	"Value-preserving" integer conversion rules	●	●	●	/	●	/
3.2.1.5	Expressions with float operands have float type	/	●	●	●	●	/
3.2.2.1	Address-of on array and function	●	●	○	/	/	●
3.2.2.1	Call-through pointer (*pkg.fn)() may be written pkg.fn()	●	●	●	●	●	●
3.2.2.2	OK to cast void to void ³	●	●	●	●	○	●
3.2.2.3	Generic pointers: void *	●	●	●	●	●	●
3.3.2.2	Prototype-with-default-sizes is compatible with no-prototype	●	●	○	●	●	○
3.3.2.2	Calling a prototyped function causes conversion (as if by ass't)	●	●	●	●	●	●
3.3.3.3	Unary plus	●	●	●	●	●	○
3.3.3.4	sizeof applies to any r-value expression	●	●	●	●	●	●
3.3.16.1	Structure assignment, return, and argument-passing	●	●	●	●	●	●
3.5.2.2	enum and tag-scope rules ¹	●	●	●	●	●	●
3.5.2.3	Tentative def for struct sb b;	○	○	○	○	●	○
3.5.3	const is independent qualifier of e.g. struct type	●	●	●	●	●	●
3.5.3	volatile preserves auto values modified after setjmp	●	●	●	●	●	/
3.5.4	Ellipsis	●	●	●	●	●	○
3.5.4	Prototypes (for declarations)	●	●	●	●	●	●
3.5.4	Prototypes (for "new-style" definitions)	●	●	●	●	●	●
3.5.7	Elided-braces rules	●	●	●	●	●	●

¹ Per 3/87 draft. ⁴ Per 4/88 draft.
² Per 12/87 draft. ⁵ Per 12/86 draft.
³ Per 9/87 draft.

Key: ● — Supported.
/ — Compiled but produced incorrect output.
○ — Failed to compile.

index. In general, the compilers divided themselves into three tiers: Watcom and Microsoft, then Turbo and Zortech, and finally Aztec and MetaWare.

Optimizing Tests

We tested the compilers' ability to perform the classic optimizations with a

benchmark developed by Melvin Klerer and Hong Liu of Polytechnic University. The benchmark comprises two functionally equivalent C source files. The first, NONOP, contains constructs that a good optimizer should be able to improve. The second, OP, is a preoptimized version of NONOP. It's written in an optimal man-

ner so that an optimizer won't be able to squeeze much out of it.

NONOP is organized into sections, each of which contains a particular optimizable construct—common subexpressions, constants that are computable at compile time, loop-invariant code, and unnecessary copies. Each section iter-

Draft reference	Description	Turbo C	Aztec C	MetaWare C	Microsoft C	Watcom C	Zortech C
		2.0	4.1d	1.4	5.1	6.5	1.07
3.5.7	Autoaggregate initializers	●	○	●	○	●	○
3.5.7	union initializers (via first member)	●	○	●	○	●	○
3.6.4.2	Long-size switch labels	●	●	●	●	●	○
3.7.2	Tentative definition for static	○	○	○	○	○	○
3.8.1	#ifdef, #elif	○	●	●	●	●	●
3.8.1	No syntax-checking of skipped groups	●	●	●	●	●	●
3.8.2	#include macro-name	●	●	○	●	○	●
3.8.3	"Hiding" of macro names	●	●	●	●	●	●
3.8.3	Benign redefinition allowed	●	●	●	●	●	●
3.8.3	Preprocessor catenation and string-izing	/	●	○	●	○	/
3.8.5	New preprocessor directive #pragma	●	●	○	●	●	●
3.8.8	Predefined macro names	○	/	○	○	●	○
4.1.3	<errno.h> ¹	●	●	○	○	●	●
4.1.5	<stddef.h>: offsetof on nested struct member ⁴	○	○	○	○	●	○
4.2	<assert.h>	●	●	●	●	●	●
4.3	<ctype.h>	●	●	●	●	●	●
4.4	<locale.h>: initial locale is "C"	○	○	○	○	●	○
4.4	localeconv, LC_CURRENCY, negative_sign ⁴	○	○	○	○	○	○
4.5	<math.h>	●	●	●	●	●	●
4.5.1	Math library sets errno when required	●	●	○	○	●	/
4.6	<setjmp.h>	●	●	●	●	●	●
4.7	<signal.h>	○	/	○	●	●	○
4.8	<stdarg.h>	●	●	○	○	●	○
4.9	<stdio.h>: OK to include more than once	●	●	●	●	●	○
4.9.1	ln <stdio.h>: FOPEN_MAX and FILENAME_MAX ²	○	○	○	○	○	○
4.9.2	Stream and file semantics: opening, seeking, text-binary	●	○	●	●	●	○
4.9.4	remove, rename	●	○	●	●	●	○
4.9.6	Full printf/scanf to new exact spec	●	/	●	/	/	/
4.9.6	scanf and ungetc push back independently ²	●	○	●	●	/	○
4.9.6	v*printf, v*scanf	●	○	●	●	●	●
4.9.9	fsetpos, fgetpos	●	○	○	●	●	○
4.10	<stdlib.h>: has size_t ²	●	●	●	●	●	●
4.10.1	strtoul, strtoul, strtod ²	●	○	/	/	/	/
4.10.4	system, atexit, getenv, EXIT_SUCCESS, EXIT_FAILURE ⁵	/	○	○	○	/	○
4.10.6	div, ldiv	●	○	○	●	●	●
4.11	<string.h>: memset and strcmp	●	●	●	●	●	●
4.11.2	memmove, strstr ¹	●	○	○	/	●	/
4.11.6.2	strerror	●	○	/	●	●	●
4.12	<time.h>	●	●	●	●	●	●
4.12.2.2	difftime	/	○	/	●	●	/
4.12.3.5	strftime	/	○	/	/	●	○

ates inside a loop that's weighted according to the frequencies (as measured by Klerer and Liu) with which programmers inadvertently use such constructs. By far, the greatest weights are assigned to routines executing constant folding and local common subexpression optimization.

The efficiency of a given compiler's optimizer is, in theory, simply NONOP's time divided by OP's time. The ideal optimizing compiler would score 1, as it would eliminate all the unneeded code from NONOP. Higher scores indicate poorer performance.

Working with the benchmarks, we

found the presence or absence of a coprocessor to be a significant factor. Both OP and NONOP are math-intensive, relying heavily on floating-point functions from the function library. Moreover, since NONOP may be forced to do more floating-point math than OP, a good (or poor)

continued

An ANSI Conformance Sampler

Thomas Plum

After a 5-year effort, the X3J11 committee unanimously voted last September to forward a proposed standard for C to ANSI for final approval. No further changes are anticipated before the standard's eventual publication early this year.

Now that it's clear exactly what standard C will look like, most C programmers will want to know how close various compilers conform to the ANSI standard. I have created a set of tests that attempt to do just that.

The ANSI standard for C does not have any subsets. There is no "partial conformance" to this standard, and there can be no "degrees of conformance." Vendors of C have been asked not to specify or claim conformance to any of the various working drafts, including the current proposed standard, which will become a full American standard only upon official publication by ANSI. Even at that point, its acceptance as an international standard depends on further decisions by the appropriate bodies of the International Organization for Standardization.

Nonetheless, until most compilers achieve official certification, it's useful to have an unofficial estimator of how closely the compilers conform to this new standard. This is the purpose of SAMPLER.88, which contains the C source code for 79 compilable tests that sample the closeness of a compiler to the soon-to-be ANSI standard for C (for information on obtaining the listing, see

page 3). SAMPLER is a limited subset of the Plum Hall validation suite for C. Test results for the six packages in the Product Focus appear in table 2.

SAMPLER in no way attempts to measure conformance to the standard. It estimates the number of areas in which a current compiler will need to be modified to achieve eventual conformance to the standard. Compared to the megabytes of source code in a full validation suite for C, it's relatively tiny.

So much for caveats. On the positive side, any compiler that embodies all the features of the May 1988 draft would pass all 79 of the tests in this file. Most of the tests in SAMPLER reflect aspects of ANSI C that have been unchanged since mid-1986; 13 tests reflect 1987 decisions, and 3 tests reflect 1988 decisions. When 1989 compilers start to satisfy all or most of these tests, programmers will truly have syntactic portability in C.

As of the date these tests were run, several vendors already had beta-test versions of their products that scored substantially better. Because of editorial lead times, some of these beta versions will reach the market by the time this article appears. Some vendors have chosen to wait until the standard is announced officially before releasing compilers that are tracking the standard. The point here is that you should inquire about the current status of each compiler that you are considering.

I wish to express my gratitude to the

authors of the six compilers for the contribution that they have made to the field of programming. Each had unique personal reasons for undertaking a project of this magnitude.

Comparisons based on SAMPLER are in no way meant as determinations of the quality of these compilers; they are simply a snapshot of one aspect of the situation at this point in time.

A thorough validation of a compiler requires much more work than SAMPLER provides. The British Standards Institution's recent competitive evaluation has selected the Plum Hall validation suite for C. It will be used by BSI, IMQ (of Italy), and AFNOR (France) in the European C validation service. Our goal is to allow programmers to write in C with the certainty that, if portably written, their programs will work in each new environment.

Thomas Plum is chairman of Plum Hall and cocreator of the Plum Hall validation suite for C. He has been vice chairman of the X3J11 committee since 1983 and is the author of five textbooks and several curricula on C, including the course used by Bell Labs. He can be reached on BIX c/o "editors." For information about the Plum Hall validation suite for C, contact Joan Hall at (609) 927-3770. SAMPLER was written by Thomas Plum and Ralph Ryan (president of Chiron Systems), with assistance from Joan Hall, Don Gallagher, and Scott Erlichman.

math library can skew the results. Keeping this caveat in mind, as well as the varying efficiencies of the code generators, you can roughly gauge the effectiveness of the optimizers.

Microsoft and MetaWare split top honors in the two (with coprocessor and without) environments, and where they didn't win, they did show adequate performance. These two compilers are known to have well-developed optimizers, so the result is not surprising.

One odd result was Watcom's performance: tied for first in one environment and dead last in the other. The more representative result is probably Watcom's good showing on the 80387-equipped Compaq. While the compiler is not designed to optimize loops, it does support

most other source optimizations. In the emulation environment, Watcom's unusually good raw times—particularly on the OP test, which Watcom executed more than twice as fast as its nearest competitor—may, ironically, account for its poor showing by magnifying idiosyncrasies in the libraries.

80x86 Specifics

The classic optimizations are rooted in textbook compiler design and can't take into account the quirks of real-world processors. The 80x86 family, with its segmented architecture, specialized registers, and dedicated string instructions, represents anything but the ideal machine around which to design a compiler.

To attain the execution speeds we've

seen these compilers display, their authors have had to address basic machine-specific issues. For our system-specific tests, we looked into the assembly language code generated by each compiler, and we correlated that with execution speed to gauge the efficiency of some common and representative operations. We wrote one function for each test, stored them in separate files, and compiled them with appropriate optimization and assembly language-listing switches. A separate (unoptimized) driver took care of running and timing the tests.

The first tests examine register use. We were looking for evidence that the compilers can retain frequently used variables in registers, rather than in

continued

PRODUCT FOCUS
OPTIMIZING C COMPILERS

Table 3: Benchmark results. We ran each test twice, once on a Compaq 386 portable equipped with an 80387 floating-point unit, and once on a Northgate 386 with no coprocessor. The specifics of each test are discussed in the text. Indexes represent an overall summary of a compiler's performance in a given area. Higher numbers are better, and a 1.00 is the highest possible score. The indexes are calculated by normalizing each test result against the best time for any compiler; the mean of these normalized figures becomes the index for a given group of tests (low-level, XLisp, optimization, and system-dependent). The compile time and code size index are calculated in the same way using results generated for each group.

	Borland Turbo C		Manx Aztec C86		MetaWare C		Microsoft C		Watcom C		Zortech C	
Low-level												
Compile time ¹	10.91	13.95	19.88	21.61	33.97	56.49	30.30	32.41	27.71	40.78	23.25	25.79
EXE size	17,508	27,348	10,862	13,712	22,512	29,632	23,372	24,883	16,000	18,200	23,594	23,746
Register int	0.41	0.44	0.40	0.43	0.38	0.43	0.38	0.41	0.25	0.30	0.37	0.41
Auto short	0.46	0.51	0.52	0.54	0.39	0.45	0.37	0.40	0.26	0.31	0.37	0.41
Auto long	1.20	1.30	1.34	1.42	1.15	1.32	1.24	1.40	0.96	1.03	1.16	1.31
Int multiply	1.20	1.50	1.46	1.68	1.46	1.69	1.15	1.40	1.19	1.48	1.18	1.47
Function call/return	1.50	1.50	1.55	1.53	1.52	1.53	1.52	1.50	1.43	1.44	1.53	1.54
Auto double	5.25	80.00	5.05	39.55	4.53	62.20	3.24	26.00	3.08	17.60	6.02	23.50
XLisp												
Compile time ¹	50.53	68.60	222.25	218.28	344.19	598.96	293.03	320.82 ²	290.31	317.31	242.66	218.69
EXE size	55,658	65,498	52,388	56,444	58,944	68,816	62,646	66,334	45,474	50,096	61,662	62,198
Float	14.97	27.80	16.30	20.65	15.11	20.71	14.59	17.49	14.72	16.86	14.61	17.35
Integer sort	41.29	42.50	50.88	50.88	41.22	41.91	36.52	37.46	32.62	33.83	53.82	56.30
Float sort	34.26	38.85	44.57	45.26	36.06	37.74	32.22	33.45	28.73	29.88	47.13	49.49
Write file	13.32	14.40	14.86	15.38	15.87	16.42	13.27	13.29	13.29	13.40	12.52	13.04
Read file	12.31	13.77	14.50	14.83	14.61	16.50	11.89	13.76	11.72	13.41	11.95	12.80
Function calls	14.99	16.51	17.98	18.45	16.31	16.81	14.39	15.02	13.78	14.89	14.72	15.59
Sieve	53.41	55.27	57.62	58.41	54.98	56.35	53.34	55.09	56.66	60.23	55.75	58.05
Optimization												
Compile time ¹	14.64	15.82	26.59	31.04	42.42	78.10	45.15	49.13	47.71	102.00	54.52	59.81
EXE size	40,832	60,512	25,336	32,456	54,528	72,272	47,942	63,526	35,888	46,516	30,856	54,902
OP	5.40	62.70	7.20	63.9 ³	4.50	51.10	3.50	60.1 ⁴	4.70	22.80	5.80	45.10
NONOP	7.10	98.80	16.70	195.7 ³	5.45	100.00	4.40	86.1 ⁴	5.80	76.20	9.20	110.50
NONOP / OP ⁵	1.3	1.6	2.3	3 ³	1.2	2.0	1.3	1.4	1.2	3.3	1.6	2.5
Object-level												
Compile time ¹	11.79	19.83	25.45	20.87	60.94	109.94	52.25	41.36	30.10	39.44	35.07	27.43
EXE size	26,242	26,242	10,050	11,476	21,760	26,784	31,218	28,806	18,426	18,426	15,434	15,570
Register usage	14.78	16.43	15.30	16.45	14.25	14.82	15.05	16.36	12.09	12.79	14.25	15.27
Pointer arithmetic	25.60	26.62	41.80	40.89	38.70	37.63	17.06	18.18	17.46	19.49	15.35	18.19
32-bit arithmetic	4.07	4.26	4.18	5.19	4.04	4.55	3.54	4.38	2.04	2.08	4.01	4.83
strncpy function	17.47	18.30	7.78	8.18	39.63	40.70	17.85	18.70	4.67	4.50	19.88	20.82
strncpy function	20.60	24.76	34.01	36.52	21.66	25.04	33.64	36.36	42.62	45.97	23.40	17.71
Minimum XLisp size⁵	64,490		56,444		67,136		65,230		49,788		61,138	
Compile time index	1.00	1.00	0.45	0.60	0.25	0.19	0.27	0.36	0.32	0.30	0.32	0.46
Code size index	0.61	0.63	0.97	0.94	0.55	0.59	0.51	0.62	0.73	0.85	0.67	0.72
Plum index	0.75	0.70	0.69	0.70	0.76	0.70	0.84	0.81	0.99	0.99	0.77	0.82
XLisp index	0.92	0.85	0.79	0.80	0.85	0.84	0.95	0.96	0.98	0.98	0.87	0.87
OPT index	0.78	0.74	0.45	0.42	0.90	0.67	0.98	0.82	0.87	0.71	0.65	0.59
System index	0.64	0.64	0.57	0.57	0.56	0.58	0.63	0.64	0.87	0.89	0.69	0.67

Times for the low-level benchmarks are in microseconds; all other times are in seconds. File sizes are in bytes. For each compiler, coprocessor times appear in the left column and emulator times in the right column.

¹ Compile times include times for compile, assemble, and link.

² Intrinsic function optimizations disabled; failed to compile with option enabled.

³ fmod function used in optimizing benchmark not supported in emulator library; used function provided by Manx.

⁴ Emulator library used rather than Alternate Math library.

⁵ Score weighted twice in index calculation.

memory. We used the following code fragment:

```
iFunction
(a1,a2,b,c1,c2,d1,d2)
a = a1 + a2 + b;
c = c1 + c2 + b;
d = d1 + d2 + b;
return a+c+d;
```

And we anticipated that an efficient compiler would generate an assembly language listing like this:

```
MOV     AX,[BP+a1 offset]
ADD     AX,[BP+a2 offset]
MOV     BX,[BP+b offset]
ADD     AX,BX
ADD     AX,[BP+c1 offset]
ADD     AX,[BP+c2 offset]
ADD     AX,BX
```

which keeps the frequently used variable *b* in *BX* and keeps a running total of the return value in the return register.

Watcom turned in an outstanding time here, 12 seconds compared to the average 14.5. The assembly language code also came closest to our ideal. Watcom keeps *b* in a register, keeps subtotals in other registers, and never makes a single swap to memory. The compiler also passes arguments in registers rather than on the stack, as is customary. This fascinating strategy contributed here and elsewhere to Watcom's outstanding performance by reducing memory accesses to an absolute minimum.

While it's true that arguments must be moved to registers by the calling function, the additional overhead of passing arguments on the stack is eliminated. Most compilers push the addresses of variables onto the stack, call the subroutine, and load the register using their addresses. Watcom's method involves only one transfer, directly from memory to register.

Zortech also scored well on the register usage test. The emitted code does keep all variables in memory, but it keeps the subtotals in registers and makes the final add (for the return value) by simply adding registers. MetaWare's close finish can be attributed to its similar scheme.

While Turbo does keep *b* in a register (*SI*), its subtotalling in memory did cost some time. Microsoft and Aztec seem to be the least efficient on this common operation, as they swap every variable in and out of memory.

A similar test involves the efficient manipulation of pointers. Consider the following code fragment:

```
int a,i,*p;
for (i=0;i<ITERATIONS;++i)
a += *(p+i);
```

We expected the compilers to recognize that *p* is loop-invariant and to keep it as the source index, which would produce code like this:

```
LO: MOV BX,CX ;i is in cx
    SHL BX,1 ;multiply for 16
        bit
    ADD AX,[SI+BX];accumulate a
    INC CX ;increment index
    CMP CX,ITERATIONS ;check
```

Microsoft did us one better, however. It first compared *ITERATIONS* to zero, and it was prepared to exit immediately if the result were true. That wasn't the case, so it then moved **p* into *SI* as anticipated, but it also moved *ITERATIONS* into *CX*. With this arrangement, the code simply LOOPed around a fragment containing nothing but

```
ADD DX,WORD PTR [SI];a is in DX
ADD SI,2
```

The LOOP command continues *CX* times. While the loop uses an ADD rather than the more efficient INC, it does eliminate a number of instructions. The LOOP construct is also far more efficient than the CMP and JLE combination. It hadn't occurred to us that the loop index itself is unnecessary in an increment-only loop.

Zortech, which actually came in first in this test, was the only other compiler that eliminated the loop index. It produced code similar to Microsoft's, but it used the CMP rather than the LOOP scheme to check the index. Where Zortech gained ground was in its initialization routine, which was significantly shorter than Microsoft's. To test this, we cranked up the number of *ITERATIONS* to make the loop time the dominant influence on overall time; this time, Microsoft finished first.

In fact, only the two compilers that finished last on our timing, MetaWare and Aztec, produced the base-plus-offset [BX+SI] instruction we had anticipated. Watcom and Turbo scored well by resisting the temptation to swap variables to memory wherever possible.

Our third test was simply to determine the ability of the compiler to do 32-bit arithmetic. Only MetaWare's compiler supports 80386-specific code, so we expected the C expression

```
long a,b,c;
```

```
a=b+c;
```

to translate to

```
MOV EAX,B
ADD EAX,C
MOV A,EAX
```

only in MetaWare's case. In reality, all the compilers produced the same code, and none of them used the 80386-specific instructions. MetaWare explained that doing so would be dangerous if the resulting application were to be used under any operating system that needed to switch from real to protected mode. As a result, the times for all the compilers were similar, but Watcom's efficient register use put it over the top.

String operations occur frequently in C (indeed, in any language), and the 80x86 family's specialized string instructions make it almost the perfect vehicle for the string-oriented functions that an ANSI C compiler must provide. We took the following two functions, *strncmp* and *strncpy*, and used a debugger to determine exactly how strings were handled.



Timing the *strncmp* function led to some interesting results. The function is designed to compare *n* characters in two strings and determine whether or not the strings are equal, and, if not equal, to determine which one is lexicographically greater. Characters in each string are compared only as long as they are equal; the first differing character causes the function to return.

We expected that the most efficient compilers would use the string-specific *REPEATwhileEqual COMPAREstring* construct rather than comparing and looping with each element in the string.

Our test used two nonequal strings. Watcom's compiler, though it used the less efficient compare and jump method, gave an outstanding performance. Every compiler but Watcom first scans the strings to determine their lengths, compares this to *n*, and uses whichever value is lowest as a loop index. It's in that loop that *REP CMPSB* is used to compare the strings by an efficient compiler. Watcom's first action is to compare the strings; it then continues to loop until *n* decrements to zero or until the program reaches a null terminator in one of the strings. Because the initial scan was skipped, Watcom turned in an excellent score.

To further explore this aberration, we reran the test with equal strings. Watcom fared very poorly, at 64.2 seconds on the

continued

In 1988, \$3.5 billion in micro-computer software will be sold worldwide. During that same time, another \$3.0 billion in sales will be lost to free distribution — better known as software piracy. And right now, Rainbow Technologies' Software Sentinel™ is protecting close to \$1.0 billion in software for developers who never wanted to be part of the free software distribution network in the first place.  The Software Sentinel hardware key is “execution control” software protection. It ships with the software and simply plugs into the PC's parallel port to be one hundred percent invisible to both user and the software. Users can make as many copies as they want. Make working submasters. Use a hard disk. Virtually anything that can be done with unprotected software. Except start freely distributing that software to other users.  The family of Software Sentinel products. Selected by the very big to the not-so-big developers of DOS, OS/2 and Xenix software in worldwide markets. To the tune of close to a billion dollars. So far.



RAINBOW TECHNOLOGIES

18011-A Mitchell South, Irvine, CA 92714 • (714) 261-0228 • TELEX: 386078 • FAX: (714) 261-0260
 Rainbow Technologies, Ltd., Shirley Lodge, 470 London Rd., Slough, Berkshire, SL3 8QY, U.K., Tel: 0753-41512, Fax: 0753-43610

Copyright ©1988 Rainbow Technologies, Inc. Software Sentinel and SentinelPro are trademarks of Rainbow Technologies, Inc.
 Xenix is a trademark of Microsoft Corporation. OS 2 is a trademark of International Business Machines Corporation.

Compaq, compared with 4.67 seconds when the strings were equal.

Turbo's compiler, which used the CMPSB instruction, turned in a good score at 17.47 seconds. In contrast to Watcom, Turbo's score increased to only 28.28 seconds when equal strings were used. All the other compilers used combinations of SCAnString and loop instructions. Aztec's compiler proved to be particularly efficient, comparing words (LODSW,SCASW) rather than bytes as

an initial check for equality.

The strncpy timing yielded less-surprising results. The strncpy function copies n characters from one string to another. It needs to determine whether the first string is actually n characters long, and it does so by looking for a null termination. We expected the copy part of the loop to be built around a MOVEString instruction.

All the compilers we examined used this construct. Only Watcom didn't gen-

erate code using the REP prefix, and it finished last on the benchmark. Turbo and MetaWare, which virtually tied for the best scores, use the REP prefix both to move the string and to scan (SCAS) the first string to determine its length.

Compilers Up Close

The benchmark figures say a lot about each package, but they can't tell the whole story. Each compiler has features that simply can't be benchmarked, like an integrated debugger or library functions that transcend the ANSI standard. While one may be an excellent performer, it may be so difficult to use that it intimidates newcomers to the language.

In the following sections, we describe some of these features that can make the difference between an outstanding compiler and one that is merely so-so. The products appear below in alphabetical order.

Borland Turbo C Professional 2.0

Borland has a well-deserved reputation for pricing good software so that users on a limited budget can get in on the action. This is no exception: The Professional version, which includes an integrated environment, Turbo's Assembler, and the Turbo Debugger, sells for \$250. It runs under DOS 2.0 or higher and requires 448K bytes of RAM and two floppy disk drives.

The integrated environment is window-oriented; from within it, you can edit, compile, and debug programs without exiting to DOS. A project facility is the integrated environment's version of make; you use it to specify multiple files to be compiled and linked. The compiler itself, which can be used either in the environment or from the command line, adds to the ANSI standard the ability to include in-line assembly language code in a remarkably flexible manner. And it compiles faster—*much* faster—than any other compiler we reviewed.

The best addition to this already well-received package is the new Turbo Debugger. It's provided as a stand-alone supplement to the debugger that comes with the integrated environment. In addition to breakpoints and watchpoints, Turbo C features a powerful data inspector that can unpack and display entire structures. Because the inspector works in conjunction with the source-level trace facility, you can literally see those structures change.

If you have an 80386 system and plenty of extended memory, you can use this debugger in so-called virtual mode—and

continued

KILL 8051 BUGS FAST.

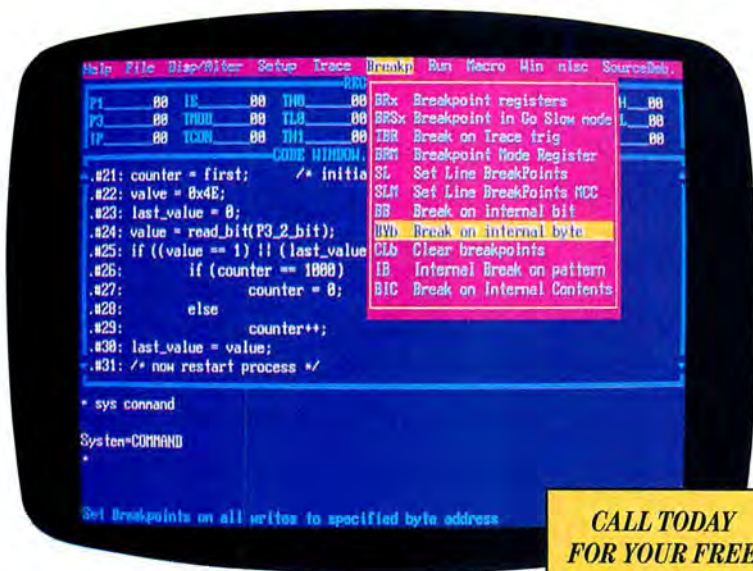

**CALL TODAY
FOR YOUR FREE
VIDEO AND
SOFTWARE DEMO.
(408) 866-1820**

Nohau's EMUL51-PC emulator and trace board make a sophisticated bug-hunting pair for your 8031/8051 projects. Plug the EMUL51-PC into your PC, XT, AT or compatible and find bugs that other emulators can't. Our powerful software makes it a snap to use.

- Source Level Debugging for PL/M-51 and C-51
- 48 bits wide 16K deep trace buffer
- 20 MHz real-time emulation
- Complete 8051 Family support including proliferation chips
- Available in either "Plug-in" or "Box" configurations



The EMUL51-PC comes with a 5-ft. cable, software and 1 year hardware warranty with free software updates. Trace board optional.

WORLDWIDE CALL:

Austria	02 22 38 76 38-0
Australia	02 654 1873
Benelux	+31-1858-16133
Denmark	02 65 81 11
France	01 69 412 801
Great Britain	01 464 2586
Israel	03 499034
Korea	04 784 7841
Portugal	01 83 56 70
Scandinavia	+46 40 922425
Spain	03 217 2340
Switzerland	01 740 41 05
West Germany	08 131 16 87

NOHAU
CORPORATION

51 E. Campbell Ave.
Campbell CA 95008
(408) 866-1820

Power

Incredible Value!

Don't take our word for it, take theirs...

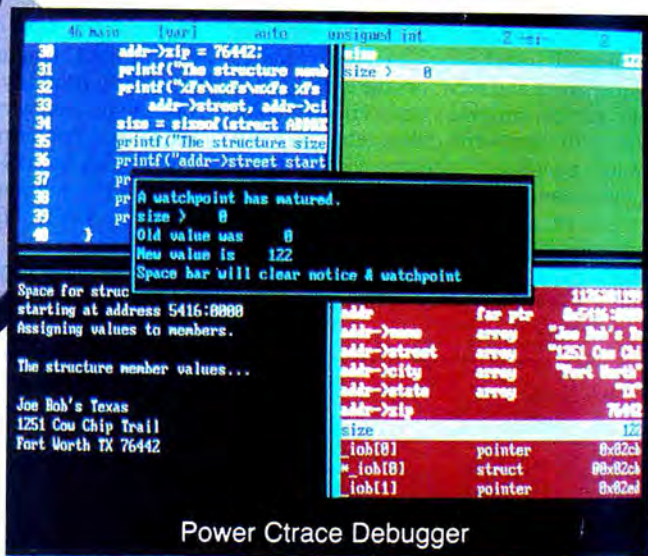

Power Ctrac Debugger

"Do you know what the underground bargain C compiler of this year is? It's the Mix Power C compiler. For under \$25 with shipping, it is one heck of a good compiler."

Victor Schneider
Dr. Dobb's Journal, June 88 (Letter to the editor)

"Overall, Power C's performance is remarkable for the price. Quite compatible with the Microsoft C and Turbo C "standards", Power C is a heavyweight contender in the educational, hobbyist, and perhaps even the professional market — at a bantamweight price."

Stephen Davis
PC Magazine, September 13, 88 (Review)

"Power C is an unbelievable product for \$19.95, and is very competitive with Turbo C, Microsoft C, and Microsoft's new Quick C in both features and performance. It is excellent for the beginner who wants to learn C, or for the experienced programmer who wants to develop professional applications. The manual alone is worth the price of this package, and the generous library source code and assembler offer adds to the value of it. If you have any desire to program in C, or want a more powerful C compiler, get a copy of Power C!"

Michael Cortese
Computer Shopper, August 88 (Review)

"The Ctrac debugger is where Mix really shines. It is magnificent. It's not only better than the stripped down debugger Microsoft includes with Quick C, it's better than the full debugger Microsoft provides with its high-end compiler (Codeview)."

David Weinberger
Computer Shopper, November 88 (Review)

Circle 159 on Reader Service Card

Technical Specifications

Power C includes: Power C compiler with integrated Make, Power C Linker, Power C Libraries (450 functions), the Power C book (680 pages), and support for...

- ✓ ANSI standard
- ✓ IEEE floating point
- ✓ 8087/80287 coprocessor
- ✓ auto-sensing of 8087/80287
- ✓ automatic register variables
- ✓ unlimited program size
- ✓ mixed model (near & far pointers)
- ✓ graphics on CGA, EGA, VGA, & Hercules

Optional Products:

- ✓ Power Ctrac debugger
- ✓ Library source code
- ✓ BCD business math

Order now by calling our toll free number or mail the coupon to Mix Software, 1132 Commerce Drive, Richardson, TX 75081.

1-800-333-0330

For technical support call: 1-214-783-6001

Minimum System Requirements:
DOS 2.0 or later, 320K memory, 2 floppy drives or hard drive.
Runs on IBM PC, XT, AT, PS/2 and compatibles.

60 day money back guarantee

Name _____
Street _____
City _____
State _____ Zip _____
Telephone _____

Paying by: Money Order Check
 Visa MC AX Discover

Card # _____
Card Expiration Date _____
Computer Name _____ Disk Size 5 1/4" 3 1/2"

Product(s) (Not Copy Protected)

<input type="checkbox"/> Power C compiler (\$19.95)	\$ _____
<input type="checkbox"/> Power Ctrac debugger (\$19.95)	\$ _____
<input type="checkbox"/> Library Source Code (\$10.00)	\$ _____
(includes assembler & library manager)	
<input type="checkbox"/> BCD Business Math (\$10.00)	\$ _____
Add Shipping (\$5 USA - \$20 Foreign)	\$ _____
Texas Residents add 8% Sales Tax	\$ _____
Total amount of your order	\$ _____

B



get most of the benefits of a hardware debugger. It installs itself in memory above 1 megabyte and monitors the execution of the subject program on a virtual 8086. As with hardware debuggers, you can watch a region of memory with minimal performance degradation.

All in all, it's quite an impressive package. Turbo C won't give you the fastest code or the smallest executable, but it's definitely the one that is the most fun to use.

Manx Aztec C86 4.1d

One of the C language's greatest selling points is portability. Manx takes full advantage of this by offering a C compiler for several operating systems, including this version for MS-DOS. It runs on systems with a minimum of DOS 2.0, 384K bytes of RAM, and two floppy disk drives.

The \$499 package is fully featured; an editor, linker, librarian, and source-level debugger come bundled with the com-

piler. The commercial version also includes object modules for generating code suitable for ROM programming and additional programming utilities.

While the compiler produces some efficient and compact code, benchmark scores were generally poor. The library functions, especially those involving the coprocessor, exhibited some obscure bugs, surprising in such a mature product. Source-level debugging is command-oriented and can be very efficient, but the debugger lacks the sexy window-oriented features supported by its current competition.

The compiler does support some unusual features designed to maintain compatibility with Aztec C for Unix systems. Since some of these are not ANSI standard, they can be enabled or disabled with a compiler switch. It makes for an easy transition between Aztec's Unix and DOS C compilers.

Overall, Aztec C suffers more than it benefits from its long and diverse heritage. The compiler seems to be a product made to fit in the DOS environment rather than designed for it; the poorly organized documentation (designed for use with different Aztec C compilers) exemplifies that problem.

MetaWare High C 286 1.4

A quick tour of table 1 may lead you to believe that High C lacks some of the basics, but that's not true. High C isn't as easy to use as some of the others, but it does everything an ANSI C compiler has to do and then some. The package requires 384K bytes of RAM and a hard disk drive, and it supports DOS 2.0 and higher.

MetaWare's extensions to C create a potent new dialect of the language: You can mix declarations and statements, use ranges in conjunction with case statements, write nested functions à la Pascal, and associate parameters by name, as in Ada. MetaWare also offers, as a \$100 option, library support for OS/2 development.

While ranged case statements and in-termixed declarations may buy some convenience, they are minor enhancements to C compared to the wholesale changes brought on by the Pascal- and Ada-like additions. Nested functions enable the programmer to define functions within other functions, with the inner function retaining all the variables local to the outer function. This makes pointer passing unnecessary when variables need to be modified by an external function and simply makes code cleaner.

continued

SUNDAY 10-5 **PROMPT DELIVERY**

Category	Item	Price	Call
APPLE	Mac SE 2-800K	2149.95	
	Mac SE w/20 M/B HD	2529.00	
	Mac SE w/40 M/B DR	3099.99	
	Mac II w/80 M/B HD	4199.99	
	Mac II w/40 M/B HD	3499.99	
	Mac II w/Res color MTR	444.99	
	Mac. Hi-Res color MTR	1029.99	
	ImageWriter II	144.99	
	ImageWriter I/O	499.99	
	Mac Scanner	194.99	
	20 M/B HD Ext.	194.99	
	40 M/B HD Ext.	194.99	
	2400 Ext. Modem	140.99	
	AST PREM 2140 X	2149.99	
	1 M/B Ram 40 M/B HD	2349.99	
1 M/B Ram 40 M/B HD	2349.99		
COMPAQ	Design 286 12 M/B	1999.00	
	1-7/10 40 M/B HD	2299.99	
	Desktop 386	4499.00	
	30 M/B HD 40 M/B	4499.00	
	386 E 40 M/B	4499.00	
	640K 1-1/2 M/B F/D	1999.99	
	30 M/B HD Dsc 3.2	249.99	
	SEAGATE DRIVES	499.99	
	20 M/B w/ICHT	499.99	
	40 M/B w/ICHT	499.99	
	40 M/B 28 M/S	1074.99	
	FACSIMILE (FAX)	1044.95	
	Canon Fax 25	1044.95	
	Pana 150/155	949.99	
	Pana UF 250	949.99	
Sharp FO 220	1069.99		
Sharp FO 420	994.95		
Toshiba 3300	994.95		
Toshiba 30100	674.99		
LASER PRINTER	1584.99		
H.P. Desk Jet II	3199.00		
H.P. Laser Jet II	3199.00		
NEC LC-890	3199.00		
PRINTERS	Brother HR-20	569.79	
	Brother Twin Whit 6	874.75	
	Diconix 150	309.99	
	Diconix 300	424.95	
	Diconix 300 W	334.95	
	Epson FX 850	474.75	
	Epson FX 1050	309.99	
	Epson LX 1050	519.99	
	Epson LX 850	184.99	
	Epson LX 1050	899.99	
	Epson LX 850	464.99	
	Epson LX 2550	514.99	
	Fujitsu DL-3400	564.99	
	NEC P-5200	369.99	
	NEC P-5218 opt	479.99	
NEC CP-6	329.95		
OKI 320	449.99		
OKI 320	599.99		
OKI 330	499.99		
OKI 393	599.99		
Panas. KXP 1080 I	154.95		
Panas. KXP 1091 I	179.99		
Panas. KXP 1124 I	309.99		
Panas. KXP 1524	369.99		
Panas. KXP 1592	409.95		
Panas. KXP 1595	409.95		
Star NX 1000	299.99		
Star NX 2400	419.95		
Toshiba 321 SL	549.99		
Toshiba 341 SL	849.99		
Toshiba 351 SX	849.99		
LAPTOP	Spak EL 640K D/D	999.99	
	Spak EL 640K 2 M/B	2099.00	
	Multi Speed EL II	2099.99	
	Multi Speed 20 M/B	2099.99	
	T-1000	719.95	
	T-1200 F/D/D	1299.99	
	T-1200 H 20 M/B	2099.99	
	T-1200 Backlit D/D	1449.99	
	T-1200 Backlit 20 M/B	2295.99	
	T-1600	2799.95	
	T-3100/20	3424.95	
	T-3200 40 M/B	4479.99	
	T-5100	CALL	
	T-5200	CALL	
	184.1 2 F/D	184.1	
194-2 20 M/B	194.2		
286 20 M/B	286		
285 40 M/B	285		
184.1 2 F/D	184.1		
194-2 20 M/B	194.2		
286 20 M/B	286		
285 40 M/B	285		
MOUSE	Logitech w/Software	45.99	
	Logitech C-7	69.99	
	Logitech Clearcase	99.99	
	Logitech Hi-Res	79.99	
	Logitech Hi-Res	99.99	
	Felix	99.99	
	Microsoft Mouse	269.99	
	Quadram Internal	CALL	
	Quadram External Port	CALL	
	Ima for XT/AT	999.99	
	Ima II w/Graphics	CALL	
	M.S. Mouse w/Res	135.00	
	M.S. Windows 286	65.00	
	M.S. Windows 386	110.00	
	M.S. Windows IBM	219.00	
M.S. Excel IBM	229.00		
M.S. Excel MAC	179.00		
M.S. Works MAC	219.00		
IBM Dor 4.0	129.00		
IBM Dor 4.0	239.00		
Lotus Agenda	399.00		
Lotus Management	119.00		
Lotus Symphony	219.00		
Manag Your Money	219.00		
Wordstar 2k p	225.00		
Wordstar 5.0	65.00		
Word Perfect 5.0	399.00		
Word Perfect Library	119.00		
Word Perfect 2.0	119.00		
Xerox Ventura 2.0	119.00		
Xerox Ventura 2.0	119.00		
Carbon Copy	469.00		
Albus Page 6M	118.00		
Albus Page 6M	118.00		
Sprint	94.99		
Horton Util. Adv.	CALL		
Fast Back	114.00		
dBase IV	58.00		
Slide Kick Plus	39.99		
Dac Easy Acct	39.99		
Fast Trax 3.0	39.99		
M.S. Flight Sims 3.1	279.99		
WP Data Protect	279.99		
SOFTWARE	M.S. Mouse w/Res	135.00	
	M.S. Windows 286	65.00	
	M.S. Windows 386	110.00	
	M.S. Works IBM	219.00	
	M.S. Excel IBM	229.00	
	M.S. Excel MAC	179.00	
	M.S. Works MAC	219.00	
	IBM Dor 4.0	129.00	
	IBM Dor 4.0	239.00	
	Lotus Agenda	399.00	
	Lotus Management	119.00	
	Lotus Symphony	219.00	
	Manag Your Money	219.00	
	Wordstar 2k p	225.00	
	Wordstar 5.0	65.00	
Word Perfect 5.0	399.00		
Word Perfect Library	119.00		
Word Perfect 2.0	119.00		
Xerox Ventura 2.0	119.00		
Xerox Ventura 2.0	119.00		
Carbon Copy	469.00		
Albus Page 6M	118.00		
Albus Page 6M	118.00		
Sprint	94.99		
Horton Util. Adv.	CALL		
Fast Back	114.00		
dBase IV	58.00		
Slide Kick Plus	39.99		
Dac Easy Acct	39.99		
Fast Trax 3.0	39.99		
M.S. Flight Sims 3.1	279.99		
WP Data Protect	279.99		
MODEMS	Hayes 1000 B	279.99	
	Hayes 2400 EXT	409.99	
	US Rob. 1200 B	84.99	
	US Rob. 1200 EXT	139.99	
	US Rob. 2400 B	154.99	
	US Rob. 2400 EXT	224.95	
	2400 for Laptop	224.95	
	Hayes 1000 B	279.99	
	Hayes 2400 EXT	409.99	
	US Rob. 1200 B	84.99	
	US Rob. 1200 EXT	139.99	
	US Rob. 2400 B	154.99	
	US Rob. 2400 EXT	224.95	
	2400 for Laptop	224.95	
	MONITORS	Amdk 410 A	139.99
Amdk 600 Color		299.99	
NEC MultiSync II		829.95	
NEC MultiSync II		829.95	
NEC Multi XL		CALL	
NEC Mono Graphic		259.99	
Princeton Max 15		649.99	
Princeton Ultrasynt		CALL	
Seiko CM 1430		CALL	
Seiko CM 1450		CALL	
Zenith ZDM 1450		228.00	
400 P.1		179.00	
Logi Scanmer		1099.00	
H.P. Scan Jet		1099.00	
GRAPHIC CARD		ATI VGA HP	249.99
	ATI VGA WONDER	254.99	
	Paradise VGA Plus 16	379.99	
	Paradise VGA Prof	CALL	
	Paradise VEGA YGA	59.99	
	Video VEGA YGA	484.95	
	Video T V Ram YGA	484.95	
	ATI VGA HP	249.99	
	ATI VGA WONDER	254.99	
	Paradise VGA Plus 16	379.99	
	Paradise VGA Prof	CALL	
	Paradise VEGA YGA	59.99	
	Video VEGA YGA	484.95	
	Video T V Ram YGA	484.95	
	SCANNERS	400 P.1	179.00
Logi Scanmer		1099.00	
H.P. Scan Jet		1099.00	
400 P.1		179.00	
Logi Scanmer		1099.00	
H.P. Scan Jet		1099.00	
400 P.1		179.00	
Logi Scanmer		1099.00	
H.P. Scan Jet		1099.00	
400 P.1		179.00	
Logi Scanmer		1099.00	
H.P. Scan Jet		1099.00	
400 P.1		179.00	
Logi Scanmer		1099.00	
H.P. Scan Jet		1099.00	

GUARANTEED LOWEST PRICES
1-800-874-1235

TOLL FREE OUT OF N.Y. IN N.Y.S. (800) 223-6779 - N.Y.C. (212) 463-8330
FAX # 212-463-8335 - 7 Days A Week

S & W COMPUTERS & ELECTRONICS
31 West 21 Street, New York, N.Y. 10011

HOURS: Sun 10-5, Mon-Thurs 9-6, Fri-Sat Closed • Credit cards charged at time of order. M.C. VISA. C.O.D. Qty. limited • Not responsible for type errors. Prices subject to change without notice. Prices are for consumers. Returns w/out written authorization.

ALL MERCHANDISE SHIPPED IN FACTORY SEALED CARTONS, 100% GUARANTEED

**Turn your favorite
C compiler into a
powerful database
manager with the**

C/Database Toolchest



The **C/Database Toolchest™** adds sophisticated file management functions to your Power C™, Turbo C®, QuickC®, or Microsoft® C compiler. With the **C/Database Toolchest™**, your data requires much less disk space than with programs like dBASE®, and you can access your data much faster. Of course the full power of C provides you with an unlimited amount of programming flexibility.

The **C/Database Toolchest™** includes three major components:

- 1) An advanced B+tree library gives you instant access to your data.
- 2) A high-level ISAM library provides you with an easy-to-use C interface, and

3) A complete database manager (with C source code included) shows you how to create impressive applications.

You also receive a comprehensive 350 page manual and a utility for converting dBASE® files.

The **C/Database Toolchest™** supports features that you'd expect to find only in products costing ten times as much. Advanced features include variable length records, variable length keys, multiple keys per index, and multiple indexes stored in a single file. Your data files can contain an unlimited number of records, and each record can be as large as 32K bytes in length.

About the only thing that the **C/Database Toolchest™** doesn't do is cost you a lot of money. We've kept our price low so you can manage your budget as easily as your data.

Now Only \$19.95!

Order now by calling our toll free number or mail the coupon to:

Mix Software
1132 Commerce Drive
Richardson, TX 75081
1-800-333-0330

60 Day Money Back Guarantee
Not Copy Protected ■ Royalty Free
For technical support, please call:
1-214-783-6001



Order Coupon

Name _____
Street _____
City _____
State _____ Zip _____
Telephone _____
Paying By Money Order Check
 Visa MC AX Disc.
Card# _____
Exp. Date _____
Disk Size _____ 5 1/4" _____ 3 1/2"

Qty.	Product	Price	Subtotal
_____	C/Database Toolchest.....	\$19.95	_____
_____	C/Database Library Source..	\$10.00	_____
	B+tree & ISAM library source code		_____
	Add Shipping (\$5 USA, \$20 Foreign).....		_____
	Texas Residents Add 8% Sales Tax.....		_____
	Total Amount of Your Order.....		_____

1	Exxon
2	General Motors
3	Mobil
4	Ford Motor
5	IBM
6	Texaco
7	E.I. du Pont
8	Standard Oil (Ind.)
9	Standard Oil of Cal.
10	General Electric
11	Gulf Oil
12	Atlantic Richfield
13	Shell Oil
14	Occidental Petroleum
15	U.S. Steel
16	Phillips Petroleum
17	Sun

27
million
Americans
can't read.
And guess
who pays
the price.

Every year, functional illiteracy costs American business billions.

But your company can fight back...by joining your local community's fight against illiteracy. Call the Coalition for Literacy at toll-free **1-800-228-8813** and find out how.

You may find it's the greatest cost-saving measure your company has ever taken.

A literate
America is a
good investment.

Ad Council  Coalition for Literacy

Company Information

Borland International, Inc.

1800 Green Hills Rd.
P.O. Box 660001
Scotts Valley, CA 95066
(800) 543-7543
(408) 438-8400
Inquiry 1040.

Manx Software Systems, Inc.

P.O. Box 55
Shrewsbury, NJ 07701
(800) 221-0440
Inquiry 1041.

MetaWare, Inc.

903 Pacific Ave., Suite 201
Santa Cruz, CA 95060
(408) 429-6382
Inquiry 1042.

Microsoft Corp.

16011 Northeast 36th Way
P.O. Box 97017
Redmond, WA 98073
(800) 426-9400
Inquiry 1043.

Watcom

415 Phillip St.
Waterloo, Ontario
Canada N2L 3X2
(800) 265-4555
Inquiry 1044.

Zortech, Inc.

366 Massachusetts Ave.
Arlington, MA 02174
(800) 848-8408
Inquiry 1045.

Named parameter associations let you pass function arguments by name rather than position, again making the source code easier to understand.

But for \$595, MetaWare ought to supply a full complement of tools. While there are some Unix-like utilities, there is no debugger, library utility, or make utility; the package doesn't even include a linker. That may not be an issue for the professional programming audience that High C targets, but it certainly makes the compiler a poor choice for novice or casual C programmers.

Microsoft C 5.1

Version 5.1 of the Microsoft C compiler adds OS/2 support to the excellent DOS-only version 5.0. The package includes the compiler, a debugger, and a set of real- and protected-mode libraries for \$450. The package supports Microsoft OS/2 1.0 or DOS 2.1 and higher, and it requires at least 448K bytes of RAM and a hard disk drive.

A number of unusual features supplement its fine performance on our benchmarks. One of them, of course, is the ability to develop OS/2 applications. The package includes library functions for OS/2 and a bind utility that creates bound executables suitable for both real- and protected-mode execution. The package also offers support for developing Windows applications.

Also included is QuickC, which implements an integrated environment for fast development. QuickC favors ease of use over a full-fledged optimization and

debugging capability. The combination of QuickC with the standard compiler and its CodeView debugger endows Microsoft C with a development versatility shared only by Watcom C.

Microsoft's CodeView debugger isn't quite as easy to use as Turbo C's, but they share most of the same features. There's also a librarian, a make utility, and a programmable text editor.

There's little not to like in the overall package. The function libraries support screen graphics as well as DOS and BIOS calls. The documentation is excellent. If anything is missing, it's the lack of the `#asm` preprocessor directive for including in-line assembly, but that one small (non-ANSI) flaw is hard to hold against an otherwise superior product.

Watcom C 6.5

This compiler isn't quite as slick as Microsoft's, and it doesn't have as many features. What it does have, however, is excellent code generation that translates into unmatched execution speed. We ran lots of tests; Watcom took more blue ribbons than any other compiler.

Watcom's \$495 compiler invites comparison with Microsoft's. It, too, includes an editor, debugger, and separate integrated environment compiler. There are also library, make, and disassembler utilities. To run it, you need at least DOS 2.0, 512K bytes of RAM, and two floppy disk drives.

Watcom's compiler turned out to be the most ANSI-compatible, according to

continued

Proof is in the Performance

db_FILE™ provides faster file management

Proven performer

db_FILE™ from Raima is the only file manager you'll ever need. Other file managers deliver B-tree/ISAM capabilities, but they slow down as the application increases in size or complexity. Only db_FILE combines B-tree/ISAM capabilities with full network model database capabilities. The result: *You get more file management for less!* Thousands of C programmers in over 50 countries worldwide use db_FILE. *And, it's fast, 100% faster than the closest competition.* So, for building applications that feature fast data access, whether simple or complex, db_FILE is the proven performer.

Proven portability

db_FILE is written entirely in C for optimum portability. Unlike others, db_FILE is not limited to MS-DOS, so your db_FILE applications will run in any environment that supports the C language. Source code is available, allowing you to optimize performance or port to new environments yourself.

More proof - db_RETRIEVE™ SQL-based Query

You can add even more performance with db_RETRIEVE™. It provides the familiar relational view, through SQL, of a db_FILE network model database...*without sacrificing the performance!* Source code is also available.

Final proof - the price.

You can't buy this much power for less! Both db_FILE and db_RETRIEVE feature free lifetime support. Plus, applications developed using db_FILE and db_RETRIEVE are royalty-free, so the savings go on and on. Call us today, and prove it to yourself!

	db_FILE	db_RETRIEVE
Single-User Object	\$ 395.00	\$ 395.00
Single-User Source*	\$ 495.00	\$ 495.00
Multi-User Object	\$ 650.00	\$ 650.00
Multi-User Source*	\$ 795.00	\$ 795.00

*Source code may only be purchased by registered owners or purchasers of compatible object code.

For the name of your db_FILE distributor.

CALL: 1-800-db-RAIMA
(that's 1-800-327-2462)

Ask about the many other products and services Raima Corporation offers, including consulting, application development services, and training.

RAIMA™
CORPORATION

68/AE



File Structure:
Based on B-tree indexing and network database model. Both access methods may be used independently or in combination for real power.

Data Types Supported:
Standard C data types plus *db_addr* for user created structures

Transaction processing supported
Not RAM resident

Operating Systems Supported:
UNIX, XENIX, MSDOS, Macintosh;
Microsoft Windows compatible

C Compilers Supported:
UNIX, XENIX, Microsoft, Lattice,
TurboC, LightspeedC, MPW

Hardware Independent

Major LANs Supported

db_FILE is upwardly compatible with Raima's db_VISTA III Database Development System.

"C" Programmers

Introducing **ZB_LIBR**, a collection of basic math and string handling routines for the C programmer. Designed with the novice programmer in mind, **ZB_LIBR** is a good starting platform for a variety of programs.

Over 40 routines to fill your basic programming needs.

** FINANCIAL **

A complete, full featured financial routine. Calculates present value, future value, number of payments, periodic payment, and interest rate. Handles user specified payment and compounding frequencies, discrete or continuous compounding, and beginning or end of period calculations.

** DATE and TIME **

To and from TRUE Julian Day Numbers (for date packing, days between dates, day of week), leap years, validity checking, several date and time conversions, date formatting, more.

** STRING HANDLING **

Translation, compaction, tokenizing, substring extraction and location, justification (L,R,Cent,Split), more.

** MATH FUNCTIONS **

Combinations, permutations, two random number generators (field & lab grade), gaussian random numbers, rounding, fractions, more.

For Microsoft C 5.x, Microsoft QuickC, and Borland's Turbo C. Complete with commented source code, examples, batch routines, and an 80 page manual. Of course you get a 30 day money back guarantee.

IDEAL FOR THOSE LEARNING 'C'.

Special introductory price of \$37.00 plus 2.50 S&H each. Add 2.00 for 3.5 inch disk format. Michigan residents, we'll pay your sales tax. Check, VISA, and MasterCard accepted.

ZAMBINI BROTHERS SOFTWARE

24634 Five Mile Rd.
Detroit, MI 48239 (313) 531-3600
Attn: ZB-LIBR 9am-6pm M-F

Name _____

Addr _____

City _____

State _____ Zip _____

Qty _____ 5.25" 3.5" Check Visa M.C.

Card No. _____

Expiration Date _____

Signature _____

byte

our validation suite. Extensions to the standard include the near, far, cdecl, pascal, and fortran identifiers found in most other compilers we reviewed. Watcom also makes extensive use of pragmas (i.e., compiler directives). You can use these to specify the registers used when making function calls (even to the 80x87) and to invoke calling conventions that may or may not be like those in C. This feature adds flexibility to the highly efficient method of passing function arguments in registers.

Some ease-of-use features are missing. While the C driver supports wild-card filenames, the compiler command line does not. And the debugger, though window-oriented, isn't as intuitive as that of some other packages.

A new release scheduled for introduction early this year promises to improve Watcom's optimizing capabilities. According to the company, the new product will focus on the classic optimizations, adding even more power to an already well-built compiler.

Zortech C 1.07

This stand-alone version of the C compiler included with Zortech's C++ package may well make a name for itself in the heavyweight C arena. The inexpensive (\$89.95) compiler lacks some of the features of those in the \$400 range, but it posted good scores on our benchmark tests, often delivering better times than the more expensive products. The product runs in 512K bytes of RAM and requires at least DOS 2.0 and two floppy disk drives.

Zortech C isn't a bare-bones compiler, however. It includes an integrated editor/compiler with WordStar-like editing commands, and you can make programs compiled with Zortech C compatible with the Microsoft CodeView debugger. According to Zortech, a new release that includes its own source-level debugger should be available by the time you read this.

Only one library is included, in contrast to the usual standard C function library, math library, and additional math library for floating-point emulations. The single library produces both 80x87 and emulated math code. Zortech's far better relative performance on our machine without an 80387 indicates that its emulation functions are much more efficient than its coprocessor code.

Two nonstandard preprocessor directives are supported—#message, which prints a message during compilation, and #exit, which sets the error level and makes a clean exit from an aborted com-

pile. Additional nonstandard features include library support for the Microsoft Mouse and for sound functions.

Optimized Choices

Our XLisp benchmark, an example of a complex and realistic application, showed how close these compilers really are. While one may have good library functions and another excellent source optimizations, for instance, overall performance of any of these compilers fits within a fairly small window.

Watcom and Microsoft are the two obvious performance standouts, splitting virtually all our tests for execution speed. While both are good in all areas, they have their own specialties; Watcom is definitely the leader in object-level optimizations, while Microsoft is strongest on the source level. Watcom's object-level expertise is evident in all the test results, and it is well matched to its target processor.

For flat-out executable speed, Watcom's compiler was the clear winner. Microsoft finished a close second. Since speed is most valuable when coupled with functionality, it pays to compare these two in the features table as well. Both compilers sport an impressive list of features, but OS/2 support and a better debugger give Microsoft a slight edge in that category.

If speed is absolutely critical and OS/2 compatibility isn't, choose Watcom. If you want to do OS/2 development now, you'll obviously choose Microsoft; and even if you're not developing for OS/2, you might still prefer Microsoft's friendlier and more powerful tools.

Finally, the other compilers have points in their favor. Turbo has by far the fastest compilation times and the best source debugger. Aztec produces the smallest executables. MetaWare combines excellent optimization with valuable language extensions. And Zortech does everything that a compiler has to do—at an attractive price. ■

ACKNOWLEDGMENT

We'd like to thank Melvin Klerer and Hong Liu of the Department of Electrical Engineering and Computer Science at Polytechnic University in Brooklyn, New York, and Thomas Plum, chairman of Plum Hall in Cardiff, New Jersey, for their assistance in providing the set of tests used in this article.

Steve Apiki is a BYTE Lab testing editor, and Jon Udell is a BYTE technical editor. They can be reached on BIX as "apiki" and "judell," respectively.

GFX Fonts & Menus...

See what you've been missing

Your C graphics library may be OK for drawing lines, circles, and pie slices, but what about features for text output and building an easy-to-use graphics interface?

Is text output lightning fast? Can you choose from a wide variety of sizes and typefaces? Can you center and right justify your text; or xor it onto the screen and move it about without destroying the background?

And how about an intuitive graphics user interface? How's your mouse control? Are you going to blow a month writing an interface with pull-down menus and dialog boxes?

Whether you're using a stand-alone graphics library or C compiler, we know you're missing most or all of these features and the GFX Fonts & Menus Library supplies them.

Fast Text Output:

On an EGA card, we're more than twice as fast as our nearest competitor; and we're just as fast on CGA, VGA and Hercules cards. Our code is fast and tight . . . the library is under 25K.

Graphics User Interface:

We've designed a full-featured graphics interface that your users will love; with pull-down menus, dialog, scroll, and forms boxes.

Easy To Code:

Data structures describe all menus and boxes. Call a function to display a structure and we'll handle all user interaction with the menu or box and return the final result.

Huge Font Selection:

We provide over a megabyte of fonts and icons that you can distribute with your programs. Many typefaces, sizes and styles.

Font & Icon Editor:

You can use our font editor to add, delete or change icons or characters; create new fonts or icon files; and scale your fonts.

C Source Code & No Royalties:

The package comes with source code ready to compile for your C compiler: Microsoft, Borland, Lattice or Metaware.

Circle 44 on Reader Service Card

Special Offer—Save Up To \$125:

Thru March 15, you can get GFX Fonts & Menus and the GFX Graphics Library at a big savings.

The GFX Graphics Library, which retails for \$125, is small, fast and comes with source code. In addition to lines, circles and pie slices, it's got scalable viewports, fast area fills and the best screen dump to a graphics printer in the business.

GFX Fonts & Menus Library

Retail	SALE
\$150	\$115

GFX Graphics + Fonts & Menus

Retail	SALE
\$275	\$150

ORDER NOW TOLL-FREE

or call for more information

1-800-872-7022, EXT 829

Visa/MasterCard/C.O.D.

Free Bulletin Board Demo

1-816-353-6038

30 Day Money Back Guarantee

Menu items can be selected with mouse or keyboard.

Use the scroll box to choose an item from a long list.

Scroll the list and select an entry with mouse or keyboard.

Over a megabyte of fonts and icons.

ACTUAL PHOTO

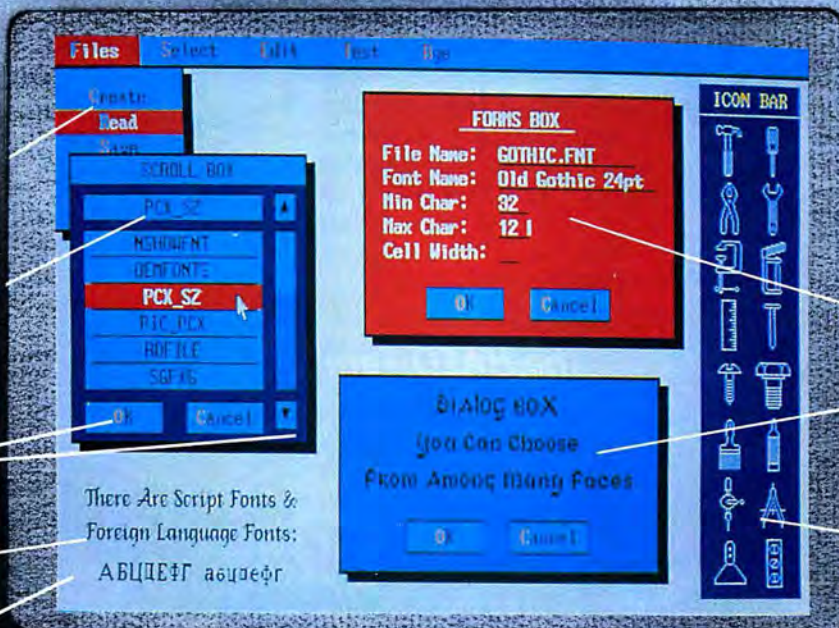

C Source, Inc.
12801 Frost Rd.
Kansas City, MO 64138
(816) 353-8808
FAX: (816) 353-6059

Easy text and data entry.

Messages and warnings are a snap.

Use icons to choose an action.

NEW UPDATE — Extended VGA Support



The Graphics Toolkit for Contemporary Software Developers

Already the fastest and most powerful graphics toolkit on the market, the new HALO® delivers subroutines and device support for exciting, contemporary applications in publishing, office automation, vision, and image processing.

HALO '88 is a device independent library of 190 graphics subroutines. It is compatible with 18 programming languages, and over 140 hardware devices such as image scanners; graphics, vision, and imaging boards; printers and plotters; and mice. HALO '88 is designed for the complete IBM compatible microcomputer line including the PS/2 and VGA.

Today's Tools for Tomorrow's Applications

HALO '88 has new subroutines which control scanners and scanned images — even images which are larger than screen resolution and available memory. Extended character set support enables software developers to address IBM's

full 255 characters in graphics and to design foreign language fonts. Among contemporary HALO '88 applications are CAD, Computer-Based Training, Presentation Graphics, Graphic Arts, Mapping, Machine Vision, Silicon Wafer Manufacturing, Sound System Design, Vehicle Scheduling and Routing, and Real Estate.

Join the HALO Family

HALO has an installed base of 60,000+ end-users, hundreds of site-licensed corporations, government agencies, universities, and national laboratories and most importantly, over 220 Independent Software Developers (ISVs) who market applications written with HALO.

HALO '88 provides the software designer with the richest environment of graphics functions; the programmer with reliable and

well-documented tools, and DP managers with continuity of user interface and database format.

Reach for the Future

If you need high performance graphics development software that provides a migration path to OS/2 and other future technology, follow the industry leaders — call (800) 992-HALO (4256).

HALO '88 is just \$325 and includes all device drivers, 20 fonts, your choice of one compiler binding, completely new documentation, an interactive tutorial and free 800# technical support.

Ask about the new HALO Programmers' Workbook which provides C program examples for HALO '88 applications developers.

media cybernetics
8484 Georgia Ave.
Silver Spring, MD 20910
(301) 495-3305, (800) 992-HALO

HALO is a registered trademark of Media Cybernetics, Inc. IBM PS/2, VGA and OS/2 are registered trademarks of International Business Machines Corp.



A Pair of Sophisticated Laptops

The Zenith SupersPort 286 and Mitsubishi MP-286L typify the current crop of portable computers

John Unger



The Mitsubishi MP-286L (left) and the Zenith SupersPort 286.

For a number of years, there were two distinct types of portable computers. First on the scene were the AC-powered Osborne, Kaypro, and Compaq portables; they offered desktop power combined with heavy weight and bulk. Next came the laptops, such as the Tandy Model 100, which initially appeared as battery-powered microcomputers that sacrificed computing power, storage capacity, and ergonomics for convenience, size, and portability. Each type of portable had its inherent advantages.

Today the distinctions between these two classes have blurred as the AC-powered portables have shrunk in size and the battery-powered laptops have increased their processor horsepower and features. The Zenith SupersPort 286 and the Mitsubishi MP-286L represent the merging of the two classes of microcomputers into mature, sophisticated machines that have the best features of both. With the current generation of laptops, exemplified by the SupersPort 286 and MP-286L, you truly have the computing power of a desktop or transportable machine and the convenient size and weight of a laptop computer.

As similar as these two computers are, they are clearly designed for two different types of users. Zenith has tried to

make the SupersPort 286 one of the best-performing battery-powered laptops, while the Mitsubishi MP-286L appears to be offered as a high-performance, lower-cost alternative to other AC-powered 80286-based laptops, such as the Toshiba T3100 and T3200 and the larger transportable computers like the Compaq Portable III.

Under the Skin

These two machines share many of the same hardware characteristics. Both feature 80286 processors running at 12 MHz, a 1.44-megabyte 3½-inch floppy disk drive, and a 20- or 40-megabyte hard disk drive. My Zenith SupersPort 286 review unit had a 40-megabyte hard disk drive, 1 megabyte of zero-wait-state RAM, and an optional internal modem; the Mitsubishi MP-286L came with a 20-megabyte hard disk drive and 640K bytes of RAM with one wait state. The SupersPort's list price with a 20-megabyte hard disk drive is \$4999; a similarly configured MP-286L costs \$3995. If you substitute a 40-megabyte drive in the SupersPort, the price jumps to \$5599.

Both computers have connectors for an optional external keypad, a Centronics-compatible parallel printer port, a nine-pin RS-232C serial port (the MP-286L has two serial ports), a connector for an

external 360K-byte 5¼-inch floppy disk drive, and a nine-pin RGB connector for an external CGA monitor.

Where these systems diverge is in their power sources. The SupersPort 286 has three major components: the main laptop unit, a removable nickel-cadmium 48-watt-hour battery pack, and an external DC power supply/battery charger. The basic computer weighs 10½ pounds, but you must also attach either the 1-pound power supply or the 4-pound battery. Zenith has gone to great lengths to cut power consumption to make a battery-powered portable practical. The SupersPort uses CMOS versions of both the 80286 CPU and optional 80287 math coprocessor chips; this cuts down on both power and heat and makes it unnecessary for this laptop to have a cooling fan.

The SupersPort has a useful monitor/setup program in ROM that is easily invoked with a Ctrl-Alt-Insert key combination. With this ROM-based software, you can perform a variety of tests and make system changes. To conserve battery power, you can use the monitor program to disable the optional internal modem, to turn off the parallel port's circuits, to select the amount of time that the display's backlighting remains on when there is no keyboard activity, and

continued

Zenith SupersPort 286**Company**

Zenith Data Systems
1000 Milwaukee Ave.
Glenview, IL 60025
(800) 842-9000

Components

Processor: 80C286 CMOS 16-bit processor running at 6 or 12 MHz, keyboard-selectable; optional CMOS 80C287 math coprocessor

Memory: 1 megabyte of RAM standard, expandable to 2 megabytes internally

Mass storage: One 1.44-megabyte 3½-inch floppy disk drive; 20- or 40-megabyte hard disk drive; optional 5¼-inch external floppy disk drive

Display: Electroluminescent backlight LCD with 10½-inch diagonal screen

Keyboard: 84 full-size keys with 12 function keys; optional numeric keypad

I/O interfaces: One RS-232C port with DB-9 connector; Centronics parallel printer port with DB-25 connector; RGB color monitor port with DB-9 connector; internal proprietary connectors for expansion memory and modem; external proprietary connectors for keypad and floppy disk drive

Size

3 × 12¼ × 12¼ inches (closed; 15½ inches deep with battery pack)
DC power supply: 6½ × 3 × 2 inches
10½ pounds; 14½ pounds with battery
AC power supply: 1 pound

Software

MS-DOS 3.21

Options

1200-bps internal modem: \$299
2400-bps internal modem: \$499
48-watt-hour battery pack: \$289
26-watt-hour battery pack: \$159
1-megabyte expansion (EMS) RAM:
\$1299
24-key detachable keypad: \$129
External 360K-byte floppy disk drive:
\$399
Three-slot external expansion chassis:
\$499
80C287 coprocessor: \$349
Technical-reference guide: \$99

Documentation

120-page SupersPort 286 Portable Owner's Manual; 540-page MS-DOS 3.21 User's Guide and User's Reference; 42-page MS-DOS 3.21 Quick Reference Guide

Price

Zenith SupersPort 286 with 20-megabyte hard disk drive: \$4999
Zenith SupersPort 286 with 40-megabyte hard disk drive: \$5599

Inquiry 859.**Mitsubishi MP-286L****Company**

Mitsubishi Electronics America, Inc.
991 Knox St.
Torrance, CA 90502
(213) 515-3993

Components

Processor: 80286 16-bit processor running at 8 or 12 MHz (one wait state at 12 MHz, zero wait states at 8 MHz); 80287 math coprocessor (optional)

Memory: 640K bytes of RAM standard, expandable to 2.6 megabytes internally

Mass storage: One or two 1.44-megabyte 3½-inch floppy disk drives or a 20-megabyte hard disk drive

Display: Page-white Neutral Twisted Nematic LCD with cold CRT backlighting; 11-inch diagonal screen

Keyboard: 86 keys with 12 function keys; optional separate 17-key numeric keypad

I/O interfaces: Two RS-232C ports with DB-9 connectors; Centronics-compatible parallel printer port with DB-25 connector; CGA monitor port with DB-9 connector; internal proprietary connectors for expansion memory and modem; external proprietary connectors for keypad and floppy disk drive

Size

3½ × 12¼ × 14¼ inches; 16 pounds

Software

MS-DOS 3.3 and GWBASIC 3.20; user diagnostics disk; Super PC-Kwik disk cache

Options

2400-bps internal modem: \$499
2-megabyte expansion RAM: \$1530
17-key detachable keypad: \$158
External 360K-byte floppy disk drive:
\$525
80287 coprocessor (factory-installed):
\$600
Microsoft OS/2: \$325

Documentation

115-page MP-286L User's Guide;
295-page MS-DOS 3.3 User's Guide;
26-page MS-DOS Quick Reference;
18-page MP-286L Quick Reference

Price

MP-286L-210 (dual 1.44-megabyte floppy disk drives): \$3195
MP-286L-220 (20-megabyte hard disk drive): \$3995
MP-286L-220VP (same as -220 but with 80287 coprocessor): \$4595
MP-286L-240E (40-megabyte hard disk drive and EGA): \$4795
MP-286L-240EVP (same as -240E but with 80287 coprocessor): \$5395

Inquiry 860.

to set the amount of time that the hard disk drive continues to spin after the last disk access. If the hard disk drive is not spinning, it takes about 8 to 12 seconds for the drive to respond to a request from the operating system.

I found that a fully charged battery provides about 4 hours of continuous operation without using any of the conservation measures. The system begins to beep pleadingly when the battery is about to die; you have 4 or 5 minutes to take some action before low battery power finally shuts down the system.

Three proprietary internal expansion slots are provided in the SupersPort: one for an internal modem, one for expansion RAM (1 megabyte), and one for an external expansion bus interface. This interface is used to connect an optional external three-slot expansion chassis to the laptop; the expansion chassis can hold three full-size, 8-bit, IBM PC XT-compatible cards. The optional 80C287 math coprocessor's socket is accessed by removing a neat trap door in the bottom of the laptop.

The MP-286L's chassis features four internal proprietary expansion buses. You can use the buses to install up to 2 megabytes of expansion RAM, a 2400-bit-per-second modem, or an additional EGA or VGA display controller for use with an external monitor. The space allotted for these slots and the MP-286L's built-in power supply and cooling fan make its case almost as long as the SupersPort's with its battery pack attached. The MP-286L's optional 80287 coprocessor must be installed by the manufacturer; it is best to purchase the machine with the chip installed if you require one for your application.

Eyes and Hands

You constantly interface with two major elements of a microcomputer: its display and its keyboard. They are important in determining how a computer feels and how effectively you can interact with whatever software you're using. These two elements are also areas where laptop computers have been consistently criticized for their shortcomings.

Liquid crystal displays have come a long way since the first laptops and their small, slow, and barely legible "light gray on dark gray" screens. Both the MP-286L and the SupersPort 286 displays have excellent contrast and are easy to read under a variety of ambient lighting conditions. The width-to-height ratio of the screens is nearly identical to that found on most CRTs: 1 to 1.3.

continued



Zenith SupersPort 286, Mitsubishi MP-286L

APPLICATION-LEVEL PERFORMANCE

Zenith SupersPort **6.4***

WORD PROCESSING		ZS 286	MP-286L	DATABASE		ZS 286	MP-286L
XyWrite III + 3.52		Med./Large	Med./Large	dBASE III+ 1.1			
Load (large)	:17	:14	Copy	1:05	1:42		
Word count	:05/:35	:05/:36	Index	:21	:22		
Search/replace	:08/:34	:08/:33	List	2:01	2:17		
End of document	:03/:20	:03/:21	Append	2:10	3:04		
Block move	:16/:16	:17/:17	Delete	:03	:04		
Spelling check	:15/1:47	:16/1:54	Pack	1:42	1:52		
Microsoft Word 4.0			Count	:18	:18		
Forward delete	:42	:41	Sort	1:27	1:45		
Aldus PageMaker 1.0a			Index:	1.28	1.05		
Load document	:21	:20	SCIENTIFIC/ENGINEERING				
Change/bold	:41	:48	AutoCAD 2.52				
Align right	:31	:35	Load SoftWest	3:36	4:13		
Cut 10 pages	:28	:32	Regen SoftWest	3:20	3:56		
Place graphic	:06	:09	Load StPauls	:58	1:04		
Print to file	2:11	4:52	Regen StPauls	:53	:55		
Index:	1.59	1.45	Hide/redraw	42:08	47:21		
SPREADSHEET		ZS 286	MP-286L	STATATA 1.5			
Lotus 1-2-3 2.01				Graphics	1:46	1:41	
Block copy	:05	:06	ANOVA	1:00	1:05		
Recalc	:02	:02	MathCAD 2.0				
Load Monte Carlo	:24	:23	IFS 800 pts.	1:54	1:58		
Recalc Monte Carlo	:11	:12	FFT/IFFT 1024 pts.	2:14	2:22		
Load rlarge3	:08	:08	Index:	0.64	0.59		
Recalc rlarge3	:02	:02	COMPILERS		ZS 286	MP-286L	
Recalc Goal-seek	:07	:07	Microsoft C 5.0				
Microsoft Excel 2.0			XLisp compile		7:09	8:45	
Fill right	:08	:09	Turbo Pascal 4.0				
Undo fill	3:30	3:23	Pascal S compile		:08	:10	
Recalc	:03	:03	Index:		1.40	1.13	
Load rlarge3	:40	:44					
Recalc rlarge3	:02	:03					

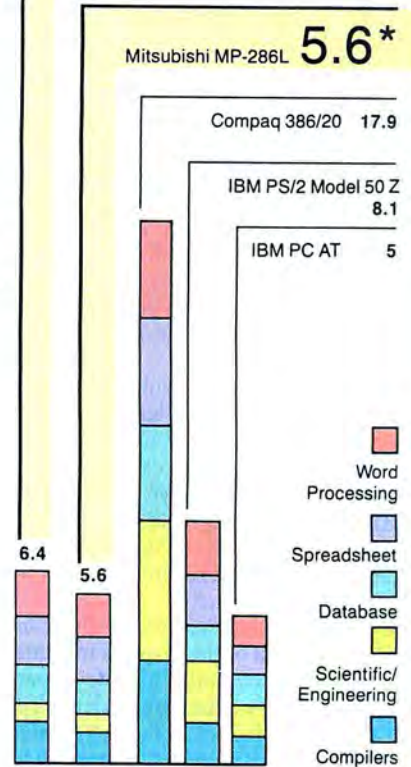

*Cumulative applications index. Graphs are based on indexes at left and show relative performance.

LOW-LEVEL PERFORMANCE¹

CPU		ZS 286	MP-286L	DISK I/O		ZS 286	MP-286L	VIDEO		ZS 286	MP-286L
Matrix		7.17	7.77	Hard Seek³				Text			
String Move				Outer track	3.31	6.63	Mode 0	10.05	9.56		
Byte-wide	69.01	52.71	Inner track	3.33	4.98	Mode 1	10.03	9.59			
Word-wide:			Half platter	9.94	21.64	Mode 2	8.29	10.38			
Odd-bnd.	52.32	52.69	Full platter	9.93	36.64	Mode 3	8.29	10.40			
Even-bnd.	34.49	26.37	Average	6.63	17.47	Mode 7	N/A	N/A			
Sieve		39.22	48.50	DOS Seek				Graphics			
Sort		39.52	38.08	1-sector	15.60	21.93	CGA:				
Index:	1.55	1.62	32-sector	62.38	60.16	Mode 4	3.33	3.52			
FLOATING POINT				File I/O⁴				Mode 5	3.33	3.52	
Math		N/A	N/A	Seek	0.26	0.22	Mode 6	3.52	3.70		
Error ²			Read	1.28	1.50	Write	1.24	1.44			
Sine(x)		N/A	N/A	Write	1.24	1.44	Mode 13	N/A	N/A		
Error			Read	1.24	1.44	Mode 14	N/A	N/A			
e^x		N/A	N/A	1-megabyte				Mode 15	N/A	N/A	
Error			Write	8.97	7.64	Mode 16	N/A	N/A			
Index:	N/A	N/A	Read	8.79	7.38	VGA:					
			Index:	1.06	0.92	Mode 18	N/A	N/A			
						Mode 19	N/A	N/A			
						Hercules	N/A	N/A			
						Index:	1.38	1.29			

N/A=Not applicable.

¹ All times are in seconds. Figures were generated using the 8088/8086 versions (1.1) of Small-C.

² The errors for Floating Point indicate the difference between expected and actual values, correct to 10 digits or rounded to 2 digits.

³ Times reported by the Hard Seek and DOS Seek are for multiple seek operations (number of seeks performed currently set to 100).

⁴ Read and write times for File I/O are in seconds per 64K bytes.

⁵ For the Livermore Loops and Dhrystone tests only, higher numbers mean faster performance.

CONVENTIONAL BENCHMARKS

	ZS 286	MP-286L
LINPACK	3800.84	4022.36
Livermore Loops ⁵		
(MFLOPS)	0.01	0.01
Dhrystone (MS C 5.0)		
(Dhry/sec)	2890	2615

Zenith SupersPort

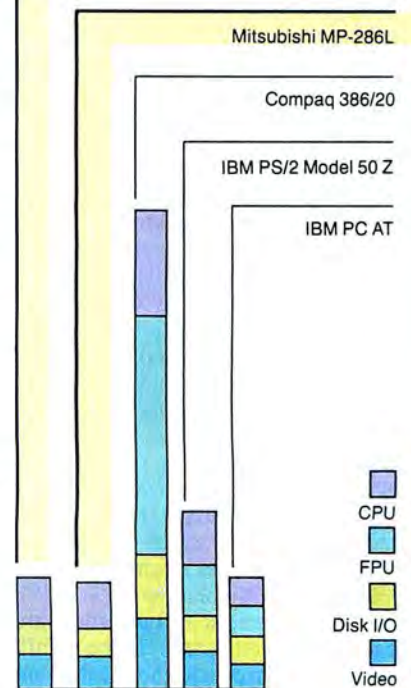

At 9 by 6¾ inches, the MP-286L's screen is slightly larger than the SupersPort's, which is 8 by 6 inches. The SupersPort's backlit screen has the familiar blue characters on a silver-gray background. The MP-286L features a very light gray background (the company calls it paper-white, but it's not) with black characters. A switch on the front of the MP-286L's screen changes the display from regular to reverse-video mode—white characters on a black background; this mode is much harder on the eyes when reading text, but it could be useful for some applications (e.g., graphics displays).

Both displays suffer from the common problem of poor cursor legibility; it is quite difficult to find the blinking underline cursor's location in a screen full of text when editing with WordPerfect or BRIEF, for example. You can improve the cursor's legibility by decreasing the contrast, but this makes the background appear dark and blotchy.

By the way, both computers have controls on the front of the displays to adjust brightness and contrast, but the SupersPort's sliding switches are easier to adjust than the MP-286L's buttons, which must be twisted with a fingertip. The range of adjustments on both machines is broad enough to give good legibility under all normal lighting conditions.

Although the MP-286L's oversize screen allows it to have characters larger than those on other laptops, I did not like the individual letters in its character set. The bottom half of characters such as the *b* and *h* and the top half of the *p*, *g*, and *q* are shorter than the other lowercase letters. This unevenness gives the text a choppy look and makes it hard to read.

Both computers can display colors as shades of gray in a CGA text or graphics mode. By judicious tweaking of the contrast and brightness controls on the two computers, I was able to display between four and six different gray shades, corresponding to sixteen different colors on a CGA monitor. When installing software that has monochrome/color display options, you are safer telling the program that your display is monochrome. The CGA option can too often result in an illegible black-on-black or white-on-white combination. Of course, if the software lets you adjust the color palette, you should be able to find a combination that works well on either laptop.

Keyboards remain a troublesome area for all laptop computers. Three significant problem areas are the location and layout of the function keys and editing keys and how the numeric keypad layout

is accommodated. The manufacturers have resorted to a variety of techniques in keyboard design to keep the size of these computers down. Mitsubishi uses the philosophy of fitting in more keys by making many of the keys smaller. The SupersPort's keys are all full-size and make use of an extra Fn key that acts like a Control, Shift, or Alt key when used in combination with other keys. In this case, Zenith's solution is better, and I found its keyboard far easier to type on and use effectively.

Both
*displays suffer from
the common problem of
poor cursor legibility.*

For example, the SupersPort has only four direction-type editing keys, located in the lower right corner of the keyboard. They are arranged in a familiar inverted *T* pattern and work as the arrow cursor keys. When used in combination with the Fn key, they become the Home, End, PageUp, and PageDown keys. Mitsubishi's solution is to put eight separate, half-size keys in the upper right corner of the keyboard, where they are much harder to reach and use productively.

The SupersPort's full-size function keys (F1 through F10) are laid out in a row at the top of the keyboard; the F11 and F12 keys' functions are accessed by using the Fn key in combination with the F1 and F2 keys. The MP-286L has its half-size function keys arranged in two rows at the top of the keyboard, with F1 to F8 in one row and F9 to F12 in the other. This layout is difficult to learn and makes you constantly hunt for the correct function key—a situation that is tiresome with a program like WordPerfect that makes heavy use of the function keys.

Performance Edge

Although these two laptops have similar hardware, the SupersPort 286 has a clear edge when it comes to overall performance. Its advantage is due to two factors: its 12-MHz 80C286 runs with zero wait states when accessing RAM, and its hard disk drive has an average access time (measured with the Coretest program) of 27 milliseconds, versus 75 ms

for the MP-286L's hard disk drive. Mitsubishi includes a disk-caching program from Multisoft, Super PC-Kwik, which compensates somewhat for its slow hard disk drive. These differences show up on the BYTE benchmarks.

Both computers perform well compared to the better desktop 80286 computers; as the benchmark results show, both laptops are faster than the IBM PS/2 Model 50, but they lag behind the newer PS/2 Model 50 Z. Neither machine was equipped with a math coprocessor chip, and this adversely affected the benchmark results.

Words and Service

Both computers come with easy-to-read setup and operating instructions. The SupersPort 286 uses MS-DOS 3.21, and the MP-286L uses MS-DOS 3.3 version 1.06. The MS-DOS manual for the Zenith laptop is larger and more complete than the MP-286L's. The MP-286L comes with GWBASIC but no BASIC manual; Zenith does not include a BASIC interpreter with the standard operating system for the SupersPort. Both laptops can run the Microsoft OS/2 operating system, which is offered as an option by both manufacturers. However, the maximum amount of RAM that the laptops can accommodate (2 megabytes for the SupersPort and 2.6 megabytes for the MP-286L) may not be sufficient to run future versions of OS/2.

Both Mitsubishi and Zenith offer a 1-year limited warranty on their laptops; Mitsubishi guarantees a 7-day turnaround on the MP-286L. You are responsible for getting the damaged goods back to either the manufacturer or one of its authorized representatives. Zenith has an excellent reputation for making quality hardware, and its support policies are also good. Mitsubishi is better known in the U.S. for its well-made audio/visual electronics equipment; if its computer equipment is as good, then the MP-286L should be trouble-free.

Last Keystrokes

The Zenith SupersPort 286 appears to be at the top of the heap of battery-powered 80286 laptops in terms of performance and battery life. Its 12-MHz zero-wait-state processor and the fast hard disk drive constitute a package challenged only by the recently announced Compaq SLT/286 and Toshiba T1600.

Running the SupersPort 286 off a battery pack has some limitations. I found that the SupersPort's 15 or 16 pounds of computer, battery pack, and AC charger/

continued

The Power Of Choice.

AST Premium Workstation/286
10 MHz, 286 CPU. Sleek, all-purpose office AT-compatible

AST Premium/286
10 MHz, 0 wait-state, 286 CPU. Top-rated AT-compatible performance

AST Premium Workstation/386SX
16 MHz, 386SX CPU. Powerful, cost-effective desktop computing

AST Premium/386C
20 MHz, 386 CPU. High-speed, 32-bit caching architecture

AST Premium 386/25
25 MHz, 386 CPU. Fastest 386 system available

When it comes to selecting name brand computers that satisfy a wide range of power requirements, AST makes your job simple.

First, for CAD/CAE, LAN, multi-user and other applications requiring the most powerful personal computer available, AST provides the 25 MHz, AST Premium® 386/25. Based on the Intel® 386 chip with an integrated cache architecture, the AST Premium 386/25 provides the ultimate solution for sophisticated processing.

For those who don't need quite so much power, AST offers the 20 MHz, AST Premium/386C with cache memory and the slim-line, 16 MHz AST Premium Workstation/386SX. Both allow you to use your current MS-DOS® applications. And take advantage of the next-generation, 32-bit operating systems and environments, including Microsoft® Windows/386, UNIX® System V/386, OS/2™ and more.

Of course, not every application requires 386 architecture. For word processing, spreadsheets or desktop publishing, the award-winning AST Premium/286 is the power of choice. Built with FASTslot™ technology and unbeatable compatibility, the AST Premium/286 provides built-in 386 CPU upgradeability when you need it.

And for extra value in a 286 PC that looks like it belongs in the executive suite, choose the AST Premium Workstation/286. As industry critics say, "This is one slick, attractive machine. . . like other AST machines, it's built like a tank."

In fact, AST's reputation for providing high-quality, top-value products extends throughout our leading board-level enhancements and connectivity solutions.

So, give yourself the power of choice—AST Premium Computers. For more information, call (714) 863-0181, ask for operator AA89.

Please send me more information on the AST family of Premium Computers.

Please have an AST representative call me.

I am an end user a reseller.

Name _____

Title _____

Company _____

Address _____

City/State/Zip _____

Phone (____) _____

Send to: AST Research, Inc. 2121 Alton Avenue,
Irvine, CA 92714-4992.

BYTE 2/89

AST markets products worldwide—in Europe and the Middle East call 44 1 568 4350; in Japan call 813 447 8303; in the Far East call 852 5 717223; in Canada call 416 826-7514. AST, AST logo and AST Premium registered trademarks AST Research, Inc. 80386 and 80386SX trademarks Intel Corp. All other product and brand names are trademarks and registered trademarks of their respective companies. Copyright © 1988 AST Research, Inc. All rights reserved.

AST
RESEARCH INC.

Times Have Changed.

power supply gets pretty heavy if you have to lug it more than a few hundred feet. Even though I carried the laptop in the convenient and well-made padded nylon case that Zenith sells as an option, it's definitely a chore. In my experience, 10 or 11 pounds is a more reasonable upper limit to comfortably tote around an airport for extended periods of time.

A more serious shortcoming of the SupersPort 286 arose when I tried to use it during a business flight. This computer

is simply too long to fit comfortably on a tray table in the coach section of a DC-10. With the computer resting on the tray, I could not open the screen to a comfortable viewing angle because it hit the back of the seat in front of me. If I slid it toward me to alleviate that problem, then the keyboard was jammed too close to my body, and typing was extremely awkward. The 3 inches that the battery pack adds to the overall length of the computer just makes it too long in this

situation. Maybe it's a machine designed for the First Class section. Despite these inconveniences, however, it was a pleasure to have such a powerful computer literally at my fingertips while traveling, and this made the problems I experienced seem minor.

The MP-286L's performance would be significantly enhanced if a hard disk drive with a faster average access time were used; the sluggish drive currently installed in the machine is not in keeping with the rest of the system's performance potential. Unless its street price is significantly less than its list price, the Mitsubishi does not represent a particularly good value. [Editor's note: After this review was written, Mitsubishi announced the MP-286L-240E, featuring a 40-megabyte hard disk drive with better than 30-ms access time and an EGA display.]

Zenith and Mitsubishi both face serious competition in the arena of AC and battery-powered laptops. There are many contenders in this category, and some have features superior to those of the SupersPort and MP-286L. For example, the Toshiba T3200 has an excellent EGA-compatible plasma display and two standard IBM expansion slots. NEC has recently announced its ProSpeed series of laptops, which also offer an EGA-compatible LCD screen.

The SupersPort and the MP-286L are a far cry from their 8088 and 8086 predecessors. Their displays are clear and bright with superior contrast; they use fast 80286 CPUs and provide internal expandability for at least 2 megabytes of RAM; and they accommodate 40-megabyte hard disk drives. All this has been accomplished without increasing their size or weight significantly.

The SupersPort 286's user interface—the display and keyboard—are better than the MP-286L's, and with its battery pack the SupersPort 286 is a more versatile package. On the other hand, both the SupersPort and the MP-286L suffer from what have become chronic laptop problems: text cursors that are difficult to find and cramped keyboards—compromises that seem unavoidable with this genre of computer. You will have to decide if higher performance, battery power, and a full megabyte of RAM are worth the \$1000 difference in list price between comparably equipped Zenith and Mitsubishi computers. ■

John Unger is a geophysicist for the U.S. government and lives in Hamilton, Virginia. He writes graphics software and uses computers to study the earth's crust. You can reach him on BIX as "junger."



"THE PC PEOPLE"

Ad Code **BL-C9**

SINCE 1977

P C SYSTEMS & LAPTOPS

FRC XT'S, Super AT'S, Tower 386 Workstations.....CALL
Nationwide on-site service available!

AST RESEARCH INC. Premium286 - Model 80CALL
Premium386 - Model 300CALL

LAPTOPS

ZENITH
SupersPort - Dual 720K fpy, 640K, 80C88-8 MHz CPU, detach. battery pak, back-ill. supertwist screen 640x200, RGB color connector for ext. monitor, clock, ser/par. ports, ext. bus (opt), only 9.7 lbs., \$1,689
With 20Mb hard drive, 720K floppy \$2,395

SupersPort 286 - 1.44Mb floppy, 20Mb hard dr., 80C286-12MHz, 1Mb, 640x400 6 shades of gray, C.S.P., RGB ports, 14 lbs. with battery pak. \$3,598

MITSUBISHI ELECTRONICS
MP286L 12mtz, 0.5wt, 640K, 11" white screen, CGA, HGC Ext Video adpt., 1.44Mb floppy, 20Mb hard drive, 2 ser/par, c/cxl, ext floppy ports, 4 proprietary slots, DOS 3.3, GV Basic..... \$2,488
MP286L with 40Mb Drive..... \$2,995

MONITORS & TERMINALS

SAMSUNG EGA III "n" swivel, 14" mon. \$359
EGA III "n" swivel color hr. res. \$239
12" TTL III "n" swivel amber. \$ 79

TATUNG
CM-1495 OmniScan 14" Multi-freq. 800x600, VGA, EGA, CGA, Tr'nS, w/VGA card \$729
CM-1496 VGA 14" w/VGA card \$699

MDS "The Genius" FULL PAGE for PC/XT/ATCALL

MONITOR 19" & 24"CALL

NEC MultiSync II (1402) \$399

WYSE WY-50 green or amber..... \$389
WY-60 w/keyboard..... \$425

XTRON

XTRON-Futuristic, flat, & non-glare w/dual mono, EGA, VGA, & Multisync models.....CALL

ZENITH FTM-1490 VGA flat screen..... \$599

PRINTERS, PLOTTERS & FAX

brother Dot matrix, daisy wheel, laser printers, fax machines. CALL

Panasonic 1592 132 Col., 100 CPS..... \$429
10801 \$169 1091 Model 2 \$199
10921 \$319 1524 \$579

heuston instrument PLOTTERS DIGITIZERS
Summagraphics
SUMMA SKETCH 12 X 12 \$365
PRO 12 X 18 \$639 MAC 12 X 12 \$389

FAX
Xerox 7007 9500 BPS, 18 second / page, a phone with 99 number auto dial, 10 pg feed, up to 7 day delayed send, 200x400 resolution, \$1,295
7011, 7018, 7020, 7021, Faxmaster/PC..... CALL

NETWORKING

VAR's Let us configure a plug N Play system ready to load your application software!

NOVELL Network
-American Research (ARC) 12MHz 4026-12/2, 1 SZP, Mem. module, 1.2Mb floppy 2Mb RAM, 720K Drive, 60Mb Tape & Disk 2.3
-American Power Conversion 520W UPS
-Novell ELS NetWare 286 Level 1
Novell System Mgr & User Basics Diskette
Base & Utilities
2400 Base Modem W/PC Anywhere for Support
-4 Arcton cards, cable, 4 port network hub
-3 Arcton ProTurbo III, 10MHz, 640K, 6.5, XTRON 14" Tr'n S Monitor
-Telephone assistance during installation. Year cost \$8,595

PC SOFTWARE & MICE

Data Base Management
Ashton-Tate dBase III PLUS \$369
PFS: Professional File \$118
WordTech DBXL (dBASE 3) "Diamond" \$115

Communications
Carbon Copy Plus (Meridian) \$109
CrossTalk XVI (Microsoft) \$98

Word Processors
NewWord (WordStar 4.0 done) \$ 98
WordStar 4.0 \$220
Microsoft Word \$225
Multiplan 3.0 \$ 95
PFS: Professional Write \$258
Word Perfect \$235

Integrated / Spreadsheets
Enable 2.0 (software group) \$369
Framework II (Ashton-Tate) \$375
Framework III \$375
Lotus 1-2-3 \$295
Multiplan Advantage II \$115
PFS: First Choice \$ 95
PFS: Professional Plan \$ 58
Symphony (Lotus) \$438

Desktop Publishing
PFS: First Publisher \$ 69
PFS: Art Gallery \$ 69
Xerox Ventura 2.0 \$409
Aldus PageMaker/PC 3.0 \$625

Graphics & Mice
Harvard Graphics (for Lotus 1-2-3) \$248
IMSI OptiMouse Serial \$ 88
IMSI Genius Mouse Serial \$ 59
Microsoft Mouse \$ 98
SummaSketch 12x12 \$365

Project Management
Harvard Total Project Manager \$349
* Compatibility with PC/XT/AT clones not guaranteed.
* Original Caddy. Opened software not returnable!

POWER ACCESSORIES

330XT \$295
450A T \$425
520 ES \$495
800RT w/UPS I/F \$795
1200VX w/UPS I/F \$925
Interface Cable \$ 25

American Power Conversion
Novell U.P.S. Monitor Board Compatible!
* 220 Volt Models Available *

LASER PRINTERS & SCANNERS

Brother HL-8 48 fonts 8PPM 2nd Gen. Canon Engine Emulates Epson, IBM, Diablo 1Mb RAM-Full P/g graphics HP LaserJet Plus compatible
\$295 CALL

AST TurboLaser/PS postscript, rich 3 Mb, 35 fonts, Apple, AppleMac/PC CALL
H.P. LaserJet Series II CALL
Panasonic 4450 Laser dual tray, 11PPM \$1,595
HP ScanJet Scanner with Starter Kit \$1,675
HP/Brother Font Cartridges FROM \$119

DRIVES - HARD, FLOPPY & TAPE

EVEREX
Everex 60' - 60Mb Internal tape with software \$988
Everex 125Mb Internal Tape \$2,149
CDC 90-300Mb SCSI CALL
Maxtor XT-1140 140Mb \$1,695

MICROPOLIS 85Mb 28mSEC
* AtusScribe 3053 1H 22mSEC 44Mb \$449
ScribeCard 30Mb Drive on a card 40mSEC \$355

Mitsubishi 44/66Mb (RL) 28mSEC
Seagate
Seagate PC 20 Mb with WD Ctrl \$ 269
Seagate PC/XT 30Mb ST-238, ctrl. cable \$ 289

Floppy Drives

Fujitsu 360K \$75/1.2 Mb \$95/720K \$98/1.44, \$109
Mitsubishi 360K \$89/1.2 \$125/720K \$99/1.44 \$119
Teac 360K CALL/1.2 \$99/720K \$88/1.44 \$ 98

MODEMS & BOARDS

ANCHOR
1200 External \$ 99 / 1200 Internal \$ 89
2400 External \$135 / 2400 Internal \$115

EVEREX
EverCom 2400 Int. \$139 / 2400E (MNP) \$189

MultiTech Multi-Modems CALL

Robotics
US Robotics Courier HST up to 19,200 bps \$629
2400 Ext \$169 / 2400 PC \$148
1200E \$ 98 / 1200 PC \$ 68

AST RESEARCH INC. Advantage-Prem-512K, S.P. \$308
Advantage PS/2 - 512K 2Mb \$365
Hot Spot 286-10XT Accel. Bd. \$369
IO MINI-I/O or AT \$ 75
RAMPAGE 286 - 512K \$395
RAMPAGE for XT 256K - Model 30 \$279
RAMPAGE for PS/2 512K microchannel \$509
SIX PAK Plus G4K \$359 / VGA \$119
VGA PLUS 64K \$259
XFORMER - AT replacement, for XT's 8 slot MB, 10 MHz "0", 512K, S.P.C., floppy and hard drive controller, EGA, CGA, HGC \$629
S25111 Plus AST Guarantees \$98
Magic I/O AT1-3 S.P.G. (170B) \$ 59
80287-B \$240 80287-10 \$285
Floppy I/O S.P.G. C \$ 89
Deluxe EGA 80x600+prt \$159
VGA \$249

int'l Above Board 286 - PCMB4020 512K \$379
80287-B \$240 80287-10 \$285
80387-20 Math Coprocessor \$479

800-528-3138 Orders Only **602-991-7870 Customer Service**
S-100 Div./696 Corp. • 14151 N. 76th St. • Scottsdale, AZ 85260
♦ TELEX 9103806778 SNSCORP ♦ FAX 602-483-0920

Advanced prices are cash, prepaid, Visa or MasterCard Only! Customers using AMEX, COD's or qualifying for terms, calculate additional charges by dividing above prices by .96. Credit card charged after shipment. Special order items require cash payment and they are not refundable. Domestic shipping next day, minimum \$4.00. 7-10 lbs. \$14.00. 11-15 lbs. \$19.00. 16-20 lbs. \$24.00. 21-25 lbs. \$29.00. 26-30 lbs. \$34.00. 31-35 lbs. \$39.00. 36-40 lbs. \$44.00. 41-45 lbs. \$49.00. 46-50 lbs. \$54.00. 51-55 lbs. \$59.00. 56-60 lbs. \$64.00. 61-65 lbs. \$69.00. 66-70 lbs. \$74.00. 71-75 lbs. \$79.00. 76-80 lbs. \$84.00. 81-85 lbs. \$89.00. 86-90 lbs. \$94.00. 91-95 lbs. \$99.00. 96-100 lbs. \$104.00. 101-105 lbs. \$109.00. 106-110 lbs. \$114.00. 111-115 lbs. \$119.00. 116-120 lbs. \$124.00. 121-125 lbs. \$129.00. 126-130 lbs. \$134.00. 131-135 lbs. \$139.00. 136-140 lbs. \$144.00. 141-145 lbs. \$149.00. 146-150 lbs. \$154.00. 151-155 lbs. \$159.00. 156-160 lbs. \$164.00. 161-165 lbs. \$169.00. 166-170 lbs. \$174.00. 171-175 lbs. \$179.00. 176-180 lbs. \$184.00. 181-185 lbs. \$189.00. 186-190 lbs. \$194.00. 191-195 lbs. \$199.00. 196-200 lbs. \$204.00. 201-205 lbs. \$209.00. 206-210 lbs. \$214.00. 211-215 lbs. \$219.00. 216-220 lbs. \$224.00. 221-225 lbs. \$229.00. 226-230 lbs. \$234.00. 231-235 lbs. \$239.00. 236-240 lbs. \$244.00. 241-245 lbs. \$249.00. 246-250 lbs. \$254.00. 251-255 lbs. \$259.00. 256-260 lbs. \$264.00. 261-265 lbs. \$269.00. 266-270 lbs. \$274.00. 271-275 lbs. \$279.00. 276-280 lbs. \$284.00. 281-285 lbs. \$289.00. 286-290 lbs. \$294.00. 291-295 lbs. \$299.00. 296-300 lbs. \$304.00. 301-305 lbs. \$309.00. 306-310 lbs. \$314.00. 311-315 lbs. \$319.00. 316-320 lbs. \$324.00. 321-325 lbs. \$329.00. 326-330 lbs. \$334.00. 331-335 lbs. \$339.00. 336-340 lbs. \$344.00. 341-345 lbs. \$349.00. 346-350 lbs. \$354.00. 351-355 lbs. \$359.00. 356-360 lbs. \$364.00. 361-365 lbs. \$369.00. 366-370 lbs. \$374.00. 371-375 lbs. \$379.00. 376-380 lbs. \$384.00. 381-385 lbs. \$389.00. 386-390 lbs. \$394.00. 391-395 lbs. \$399.00. 396-400 lbs. \$404.00. 401-405 lbs. \$409.00. 406-410 lbs. \$414.00. 411-415 lbs. \$419.00. 416-420 lbs. \$424.00. 421-425 lbs. \$429.00. 426-430 lbs. \$434.00. 431-435 lbs. \$439.00. 436-440 lbs. \$444.00. 441-445 lbs. \$449.00. 446-450 lbs. \$454.00. 451-455 lbs. \$459.00. 456-460 lbs. \$464.00. 461-465 lbs. \$469.00. 466-470 lbs. \$474.00. 471-475 lbs. \$479.00. 476-480 lbs. \$484.00. 481-485 lbs. \$489.00. 486-490 lbs. \$494.00. 491-495 lbs. \$499.00. 496-500 lbs. \$504.00. 501-505 lbs. \$509.00. 506-510 lbs. \$514.00. 511-515 lbs. \$519.00. 516-520 lbs. \$524.00. 521-525 lbs. \$529.00. 526-530 lbs. \$534.00. 531-535 lbs. \$539.00. 536-540 lbs. \$544.00. 541-545 lbs. \$549.00. 546-550 lbs. \$554.00. 551-555 lbs. \$559.00. 556-560 lbs. \$564.00. 561-565 lbs. \$569.00. 566-570 lbs. \$574.00. 571-575 lbs. \$579.00. 576-580 lbs. \$584.00. 581-585 lbs. \$589.00. 586-590 lbs. \$594.00. 591-595 lbs. \$599.00. 596-600 lbs. \$604.00. 601-605 lbs. \$609.00. 606-610 lbs. \$614.00. 611-615 lbs. \$619.00. 616-620 lbs. \$624.00. 621-625 lbs. \$629.00. 626-630 lbs. \$634.00. 631-635 lbs. \$639.00. 636-640 lbs. \$644.00. 641-645 lbs. \$649.00. 646-650 lbs. \$654.00. 651-655 lbs. \$659.00. 656-660 lbs. \$664.00. 661-665 lbs. \$669.00. 666-670 lbs. \$674.00. 671-675 lbs. \$679.00. 676-680 lbs. \$684.00. 681-685 lbs. \$689.00. 686-690 lbs. \$694.00. 691-695 lbs. \$699.00. 696-700 lbs. \$704.00. 701-705 lbs. \$709.00. 706-710 lbs. \$714.00. 711-715 lbs. \$719.00. 716-720 lbs. \$724.00. 721-725 lbs. \$729.00. 726-730 lbs. \$734.00. 731-735 lbs. \$739.00. 736-740 lbs. \$744.00. 741-745 lbs. \$749.00. 746-750 lbs. \$754.00. 751-755 lbs. \$759.00. 756-760 lbs. \$764.00. 761-765 lbs. \$769.00. 766-770 lbs. \$774.00. 771-775 lbs. \$779.00. 776-780 lbs. \$784.00. 781-785 lbs. \$789.00. 786-790 lbs. \$794.00. 791-795 lbs. \$799.00. 796-800 lbs. \$804.00. 801-805 lbs. \$809.00. 806-810 lbs. \$814.00. 811-815 lbs. \$819.00. 816-820 lbs. \$824.00. 821-825 lbs. \$829.00. 826-830 lbs. \$834.00. 831-835 lbs. \$839.00. 836-840 lbs. \$844.00. 841-845 lbs. \$849.00. 846-850 lbs. \$854.00. 851-855 lbs. \$859.00. 856-860 lbs. \$864.00. 861-865 lbs. \$869.00. 866-870 lbs. \$874.00. 871-875 lbs. \$879.00. 876-880 lbs. \$884.00. 881-885 lbs. \$889.00. 886-890 lbs. \$894.00. 891-895 lbs. \$899.00. 896-900 lbs. \$904.00. 901-905 lbs. \$909.00. 906-910 lbs. \$914.00. 911-915 lbs. \$919.00. 916-920 lbs. \$924.00. 921-925 lbs. \$929.00. 926-930 lbs. \$934.00. 931-935 lbs. \$939.00. 936-940 lbs. \$944.00. 941-945 lbs. \$949.00. 946-950 lbs. \$954.00. 951-955 lbs. \$959.00. 956-960 lbs. \$964.00. 961-965 lbs. \$969.00. 966-970 lbs. \$974.00. 971-975 lbs. \$979.00. 976-980 lbs. \$984.00. 981-985 lbs. \$989.00. 986-990 lbs. \$994.00. 991-995 lbs. \$999.00. 996-1000 lbs. \$1004.00.

194 B Y T E • FEBRUARY 1989

Circle 260 on Reader Service Card (DEALERS: 261)



PS/2 model 30/20 meg	1775
PS/2 model 50/20 meg	2595
PS/2 model 60/40 meg	3395
PS/2 model 60/71 meg	4100
PS/2 model 80/40 meg	4595
PS/2 model 80/115 meg	6295

Call for other models



386 S 40 meg	3595
386 130 meg/20 MHz	6295
286 40 meg	2195
386 110 meg/25 MHz	7495
386 60 meg/20 MHz	5195
Portable III 40 meg/12 MHz	4095

CARD & MONITOR EXTRA
Call for other models

Macintosh

Mac-SE/20 Meg	2849
Mac-II/40 Meg	4249
Mac-SE12 Drive	2295
Call for 60 and 100 Meg	
Lazer NT	3595
Lazer NTX	5195

LOW PRICE LEADER

SINCE 1983

LAP-TOP

Compaq SLT 286-20	Call
SLT 286-40	Call
Toshiba T1000	769
T1200F	1395
T1200HB	2395
T3200-40 Meg	3495
T5100	4595
Zenith Supersport	
286-20 Meg	3195
286-40 Meg	3695
8088-20 Meg	Call
Epson LT	Call
NEC EL w/case	1295
Mitsubishi 286-20	2595



Everex

Step 286 - 12 & 16 MHz & 20 MHz
1 Meg RAM
Set up utility in ROM
S/P, C/C
Enhanced keyboard
1.2 MB floppy
DOS/BASIC

Call! for your configuration

Everex

Step 386-20 MHz & 16 MHz & 25 MHz
256K cache of very high speed RAM
2 Meg RAM, expandable to 16 Meg
S/P, C/C
Enhanced keyboard
1.2 MB floppy
DOS/BASIC
Everex 1800 Available

Call!



AST 386 40 Meg	3495
AST 286 model 80	1595
AST 286 model 120	Call
AST 286 model 140	2595

CARD & MONITOR EXTRA

WE STOCK

CITIZEN
OKIDATA
EVEREX
GOLD STAR

TOSHIBA
NEC
WYSE
HITACHI

PRINCETON GRAPHICS
SONY
ACER
HOUSTON INSTRUMENTS

AMDEK
HAYES
SAMSUNG
CALCOMP

PC MOUSE
MICROSOFT MICE
LOGITECH
MITSUBISHI

IRWIN & ARCHIVE
TAPE BACK
TAXAN
MAGNOVOX

BOARDS

Paradise VGA +	285
Vega VGA	279
Everex EVGA	265
Everex EGA	159
Tatung 16 bit	275

SOFTWARE SPECIALS

dBase IV	455
Wordperfect	239
Aldus Pagemaker	450
Ventura Publisher	475
Clipper	415
Quatro	145



NOVELL
Authorized Dealer

PRINTERS

EPSON

LX-800/LQ-500	195/315
LQ-850/1050	535/735

OKIDATA

320/321	335/460
390/391	460/635

TOSHIBA

321-SL/341-SL	485/595
351-SX 350 CPS	945

BROTHER

1709-9 PIN	425
1724-24 PIN	595

LASER PRINTERS

HP Laser II	1695
HP Desk Jet	675
Panasonic 4450	1549
Brother HL-8	1895
Nec LC 890	3295
PageLaser 12	\$\$\$\$

MONITORS

Nec Multisync II	575
Nec Multisync Plus	875
Nec Multisync XL-19"	2095
Samsung EGA	335
Goldstar VGA	375

FAX MACHINES

Sharp FO 220	950
Sharp FO 420	1195
Canon	Call
Minolta	Call
Brother	Call
Richo	Call

Intel Coprocessors

8087-3	105
8087-2	145
80287-6	175
80287-10	285
80387-16	485
80387-20	549
80387-25	695

MODEMS

Everex 1200 Int	89
Everex 2400 Int	149
Hayes 1200 B	275
More in Stock	Call

WE ACCEPT LC, CASHIER CHECKS, MONEY ORDERS, VISA, MC, AmEx
3% charge on VISA, MC & 5% on American Express

EXPORTS Available

COMPUTERLANE

HOURS:
M-S 9-6

1-800-526-3482 (Outside CA)
(818) 884-8644 (In CA)
(818) 884-8253 (FAX)

22107 ROSCOE BLVD.
CANOGA PARK
1/2 BLOCK W. OF TOPANGA
CA 91304

CORPORATE ACCOUNTS WELCOME
CALL FOR VOLUME DISCOUNTS
CONSULTANTS CALL FOR PRICING

Prices subject to change without notice

Compaq is a Registered Trademark of Compaq
IBM is a Registered Trademark of International Business Machines



"The Dataworld 286 [12MHz] AT compatible... [is]... the fastest machine of the nine tested in that review [July 1988]." (September 27, 1988).
and
... speed and excellent compatibility... hundreds of dollars less expensive than other AT compatible.



EDITOR'S CHOICE

**NOW!
20MHz 286
SI = 22.5**

"Marvelously cheap, powerful alternative ... outperformed the other 286's ..."

(October 11, 1988)



DATA-286 12MHz

80286 running at 8/12MHz, 0/1 wait state
Phoenix BIOS std. (Award BIOS opt.)
512KB of RAM, expandable to 1MB on board
Socket for 80287-8, -10
200W power supply
Real-time clock with battery backup
1.2MB floppy disk drive
Floppy/hard disk controller
(1:1 interleave controllers available)
101-key keyboard with "click"
Mono card w/parallel port (720x348)
TTL monitor with tilt/swivel base

\$1195



Portacomp II

80286 running at 8/12MHz, 0/1 wait state
Phoenix BIOS std. (Award BIOS opt.)
512KB of RAM, expandable to 1MB on board
Socket for 80287-8, -10
Real-time clock with battery backup
1.44MB 3.5" floppy disk drive
20MB, 39ms, self-parking hard drive
102-key keyboard with "click"
Supertwist backlit LCD, 640x400 res.
RGB/monochrome output port
Weighs under 20 Lbs.
1.2MB external floppy drive opt.
Carrying case available

\$1975



DATA-286 20MHz

80286 running at 10/20MHz
AWARD BIOS std.
1MB of RAM, exp. to 2MB on board
EMS 4.0 support for memory over 1MB
Socket for 80287
200W power supply
Real-time clock with battery backup
1.2MB floppy disk drive
1:1 interleave floppy/hard disk controller
101-key keyboard with "click"
Mono card w/parallel port (720x348)
TTL monitor with tilt/swivel base

\$1555

COMPLETE 10MHz DESKTOP SYSTEMS FROM \$945.00



Vertical Case

Front panel on/off switch
220W power supply
6 half-height drive bays
Dimensions: 16 3/4"(D) x
7 3/8"(W) x 25 5/8"(H)
Available for 286-/386- models



DATA-386

4.77/6/8/16MHz (20MHz opt.)
1MB of RAM, exp. to 10MB
Phoenix BIOS std. (Award opt.)
220W power supply
1.2MB floppy disk drive
Floppy/hard disk controller
101-key keyboard with "click"
Five 16 and two 8-bit slots
Mono card and monitor **\$1995**



Portacomp I

80286 8/12MHz, 0/1 wait
Phoenix BIOS std. (Award opt.)
512K RAM (exp. to 1MB)
200W power supply
1.2MB 5.25" floppy drive
20MB hard disk drive
Supertwist backlit LCD
RGB output port
5 expansion slots
1 parallel, 2 serial ports **\$1875**



Dataworld Keyboard

101-key enhanced layout
L-shaped large return key
Integrated dust cover (paper rest)

\$89



Color-coded key set for
WordPerfect available



Prices subject to change. No charge for credit card, check, C.O.D. 30 day moneyback guarantee (Shipping charges non-refundable).

Dealer/overseas inquiries welcome

In-Calif. 1-800-722-7734 INFO: (213) 695-3777

Out-Calif. 1-800-722-7702 TECH: (213) 699-8250

Monday through Friday, 7 A.M. to 6 P.M. Saturday 9 A.M. to 3 P.M. PST.

3733 San Gabriel River Parkway, Pico Rivera, CA 90660-1495





A PS/2 in Channel Only



The Tandy 5000 MC has a hybrid design, offering PS/2 compatibility combined with traditional PC features

Mark L. Van Name

With its delivery of the Tandy 5000 MC, Tandy has become the first vendor to ship a Micro Channel-compatible PC. While such PCs are often referred to as "PS/2 clones," the 5000 MC differs in many ways from IBM's PS/2s.

A Micro Channel Clone

The 5000 MC has an IBM Micro Channel-compatible bus. BYTE supplied me with an MS-DOS-compatible Micro Channel add-on card, an IBM 4-megabyte memory-expansion option—that one worked like a champ. The 5000 MC noted the extra board when it booted and told me to reconfigure the system. I inserted Tandy's reference disk, which contains PS/2-style configuration software from Phoenix Technologies, and rebooted the system. That software also told me of the setup error and asked if I

wanted it to handle the situation for me. I said yes, a few screens went by, and the new board was up and running.

It really was simpler than messing with DIP switches and the usual IBM PC AT setup programs. This experience clearly illustrated some of the nicer points of the autoconfiguring nature of Micro Channel expansion cards.

I also tried an Arnet eight-serial-port card. The 5000 MC noticed the card and asked me to add its drivers to the reference disk. It knew the right names for the drivers, so it was able to read the board's Micro Channel ID. I was unable to test it further, however, because the board did not come with an MS-DOS driver.

Although this testing was admittedly very limited, the 5000 MC appears to work with Micro Channel-compatible cards. Further testing might turn up a few incompatibilities, but Tandy has definitely taken a strong first step into the world of PS/2 compatibility.

The Complete Package

The rest of the 5000 MC is a very reasonable system, with a 20-MHz 80386 at its heart. The 80386 gets help from an Intel 82385 cache controller and a 32K-byte cache of 35-nanosecond static RAM (SRAM). This cache system lets it work with the 5000 MC's 2 megabytes of 100-ns dynamic RAM (DRAM) without wait states over 90 percent of the time.

The basic 5000 MC also includes a socket for a 20-MHz Intel 80387 math coprocessor and a 1.44-megabyte 3½-inch floppy disk drive, much like a PS/2 system. It follows the basic PS/2 design further by including circuitry on the motherboard that supports a DB-9 serial port, a DB-25 parallel port, a 6-pin DIN keyboard connector, a 6-pin DIN mouse connector, a DB-15 analog monitor connector that provides VGA compatibility, and a controller that supports two daisy-chained floppy disk drives.

All these connectors except for the

continued

Tandy 5000 MC

Company

Tandy Corp.
1800 One Tandy Center
Fort Worth, TX 76102
(817) 390-3700

Components

Processor: 20-MHz 32-bit 80386; socket for 20-MHz 80387 math coprocessor

Memory: 2 megabytes of 32-bit, 100-ns DRAM; 32K bytes of 35-ns SRAM cache; 128K bytes of BIOS ROM

Mass storage: One 1.44-megabyte 3½-inch floppy disk drive; 80-megabyte hard disk drive

Display: Tandy VGM-300 VGA-compatible analog monitor

Keyboard: 101 keys in IBM Enhanced layout

I/O interfaces: RS-232C serial port with DB-9 connector; DB-25 parallel port; analog monitor port with DB-15 connector; 6-pin DIN keyboard connector; 6-pin DIN mouse connector; proprietary 32-bit expansion slot for removable CPU board; two proprietary 32-bit expansion slots for memory-expansion adapters; two 32-bit and three 16-bit Micro Channel-compatible slots

Size

17 × 15½ × 6⅞ inches; 26½ pounds

Software

Tandy reference disk with configuration utilities, disk utilities, feature control, and POST error handler

Options

Memory-expansion adapter with 0K RAM: \$100

1-megabyte memory kit: \$649

80387 math coprocessor: \$1095

ST-506 MFM hard disk drive controller-MC: \$380

ESDI controller-MC: \$430

SCSI host adapter: \$500

40-megabyte hard disk drive: \$1299

80-megabyte hard disk drive: \$2299

VGM-300 VGA monitor: \$629

VGM-200 VGA monitor: \$500

VGM-100 monochrome monitor: \$200

MS-DOS 3.30 (includes GWBASIC 3.30): \$120

1.2-megabyte 5¼-inch floppy disk drive kit: \$300

360K-byte 5¼-inch floppy disk drive kit: \$200

Documentation

Tandy 5000 MC Installation and Operation Manual; RGB Analog Monitor VGM 200/300 Owner's Manual

Price

Basic system: \$4999

System as reviewed: \$7748

Inquiry 858.

floppy disk drive controller are accessible from the back of the system unit. One particularly nice touch is that each of these connectors is labeled in raised letters on the case.

Because all this support circuitry is part of the motherboard, the 5000 MC is also able to offer five Micro Channel-compatible expansion slots in a system with a footprint smaller than an AT's.

This basic 5000 MC package runs \$4999. Of course, to use it you need a monitor and an operating system, and you almost certainly will want a hard disk drive. Tandy offers two packaged versions with a 40-megabyte or 80-megabyte hard disk drive for \$6499 or \$6999, respectively. However, neither of these packages includes a monitor or an operating system.

My evaluation system was the 80-megabyte hard disk drive package, with Tandy's top-of-the-line, VGA-compatible analog monitor and MS-DOS 3.30 added. Total price: \$7748.

For comparison, the closest true PS/2 is probably the IBM Model 70-121. That system's basic configuration differs from the 5000 MC in three major ways: It has no cache system, its disk drive is bigger (120 megabytes), and it has only three open Micro Channel slots. The basic Model 70-121 runs \$7995, or about \$1000 more than the 5000 MC. So, if you want the Micro Channel bus, the 5000 MC clearly offers a price incentive.

In the world of conventional AT-compatible PCs, probably the closest comparable system is Compaq's new 386/20E. Like the PS/2s, the Compaq has many of its basic features built into the motherboard. Its standard memory is only 1 megabyte, it contains four AT-compatible slots, and its floppy disk drive is a 5¼-inch unit, but otherwise it and the 5000 MC offer the same basic features. The 40-megabyte hard disk drive version of the Compaq 386/20E lists for \$6599, or just \$100 more than the 40-megabyte 5000 MC package—but you still have to buy another megabyte of memory from Compaq to make the two systems comparable. That makes the 5000 MC a reasonably priced alternative to traditional AT-compatible systems as well, although there are certainly many 20-MHz systems out there that are cheaper than either Tandy's or Compaq's.

Performance?

As you can tell from the accompanying performance chart, the 5000 MC's performance, like its price, falls somewhere in the middle of the pack of the 20-MHz 80386-based systems. I compared its

BYTE benchmark results closely with those of two other systems: the Compaq 386/20 and the IBM PS/2 Model 80-111.

Basically, the 5000 MC loses to the Compaq, with an overall application index that is 20 percent slower, but it beats the Model 80's overall application index by about 8 percent.

The 5000 MC actually beats out the 386/20 by a hair on the CPU tests, but it loses all the other tests. Its biggest losses are in the video and disk tests. Its 11 percent slower video performance is not surprising, since Compaq's VGA system is one of the industry's fastest. The 5000 MC's large (44 percent slower) loss on the disk tests is probably due to its ST-506-compatible disk; the Compaq unit contained a faster, enhanced-small-device-interface (ESDI) controller.

The 5000 MC's only significant loss to the IBM Model 80-111 also came on the disk tests. Again, it was competing with a faster ESDI drive, so that loss is not surprising.

These differences should decrease when Tandy ships its ESDI controller for the 5000 MC. While Tandy currently lists that controller among the system's options, a Tandy spokesperson said that the controller was not yet available when Tandy sent the review system to BYTE.

Compatibility?

The evaluation unit may have lost the disk race, but it came through like a champ on software compatibility. It ran every program I threw at it, including Borland's Quattro 1.0, Reflex 1.14, SideKick Plus 1.0, SuperKey 1.16A, Turbo Basic 1.1, Turbo C 1.0, and Turbo Pascal 4.0; Digital's Smalltalk/V 1.2; Kermit 2.30; a copy-protected Lotus 1-2-3 version 2.01; MicroPro's WordStar 3.3 and 4.0; Microsoft's PC Paintbrush 2.0, Windows/386 version 2.03, and Word 4.0; the Norton Utilities 3.00; Quarterdeck's DESQview 2.0, with the Quarterdeck Expanded Memory Manager 386 version 1.10; and Symantec's Q&A 1.1.

Tandy is not yet shipping a version of OS/2 that will work with the 5000 MC's Micro Channel-compatible bus. Tandy offers Microsoft OS/2 1.00 for many of its other PCs, however, and a Tandy spokesperson said that Tandy would soon be including support for the 5000 MC.

Going Inside

Opening the unit is fairly easy: You just remove three Phillips screws on the back, pull the sides of the cover a bit apart, and push the cover forward. Still,

continued



Tandy 5000 MC

APPLICATION-LEVEL PERFORMANCE

Tandy 5000 MC **14.3***

WORD PROCESSING

XyWrite III+ 3.52	Medium/Large
Load (large)	:15
Word count	:02/:16
Search/replace	:04/:20
End of document	:01/:14
Block move	:09/:09
Spelling check	:06/:49

Microsoft Word 4.0	
Forward delete	:12

Aldus PageMaker 1.0a	
Load document	:15
Change/bold	:24
Align right	:18
Cut 10 pages	:17
Place graphic	:04
Print to file	1:38

Index: **2.97**

SPREADSHEET

Lotus 1-2-3 2.01	
Block copy	:02
Recalc	:01
Load Monte Carlo	:17
Recalc Monte Carlo	:04
Load rlarge3	:04
Recalc rlarge3	:01
Recalc Goal-seek	:02

Microsoft Excel 2.0	
Fill right	:04
Undo fill	1:30
Recalc	:02
Load rlarge3	:22
Recalc rlarge3	:01

Index: **3.23**

DATABASE

dBASE III+ 1.1	
Copy	1:01
Index	:22
List	1:27
Append	1:37
Delete	:02
Pack	1:23
Count	:19
Sort	1:19

Index: **1.50**

SCIENTIFIC/ENGINEERING

AutoCAD 2.52	
Load SoftWest	:42
Regen SoftWest	:29
Load StPauls	:10
Regen StPauls	:05
Hide/redraw	9:05

STATA 1.5	
Graphics	:19
ANOVA	:12

MathCAD 2.0	
IFS 800 pts.	:12
FFT/IFFT 1024 pts.	:12

Index: **4.35**

COMPILERS

Microsoft C 5.0	
XLisp compile	4:14
Turbo Pascal 4.0	
Pascal S compile	:05

Index: **2.23**

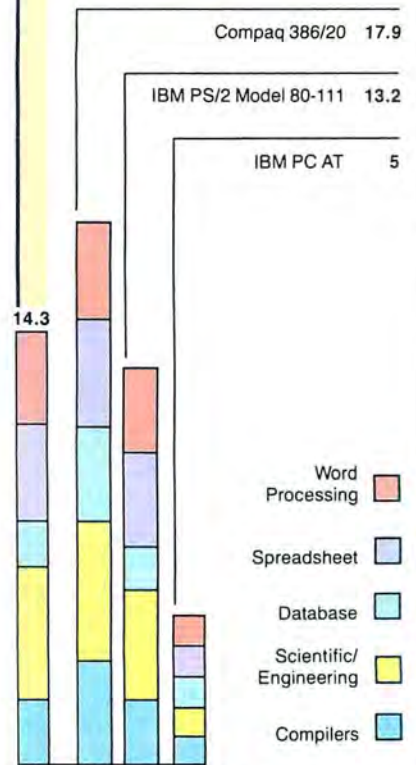

*Cumulative applications index. Graphs are based on indexes at left and show relative performance.

All times are in minutes:seconds. Indexes show relative performance; for all indexes, an 8-MHz IBM PC AT=1

LOW-LEVEL PERFORMANCE¹

Tandy 5000 MC

CPU	
Matrix	3.39
String Move	
Byte-wide	24.27
Word-wide:	
Odd-bnd.	30.36
Even-bnd.	12.18
Doubleword-wide:	
Odd-bnd.	21.03
Even-bnd.	6.09
Sieve	17.85
Sort	13.46

Index: **3.71**

FLOATING POINT	
Math	6.60
Error ²	
Sine(x)	2.09
Error	
e^x	2.35
Error	

Index: **7.91**

DISK I/O	
Hard Seek³	
Outer track	3.33
Inner track	3.29
Half platter	6.68
Full platter	10.00
Average	5.83
DOS Seek	
1-sector	11.22
32-sector	55.18
File I/O⁴	
Seek	0.16
Read	1.25
Write	1.05
1-megabyte	
Write	7.74
Read	9.23

Index: **1.25**

VIDEO	
Text	
Mode 0	4.08
Mode 1	4.08
Mode 2	4.39
Mode 3	4.37
Mode 7	N/A
Graphics	
CGA:	
Mode 4	1.48
Mode 5	1.49
Mode 6	1.65
EGA:	
Mode 13	3.50
Mode 14	4.01
Mode 15	N/A
Mode 16	3.95
VGA:	
Mode 18	4.14
Mode 19	1.57
Hercules	N/A

Index: **2.26**

CONVENTIONAL BENCHMARKS	
LINPACK	177.74
Livermore Loops ⁵	
(MFLOPS)	0.21
Dhrystone (MS C 5.0)	
(Dhryst/sec)	6281

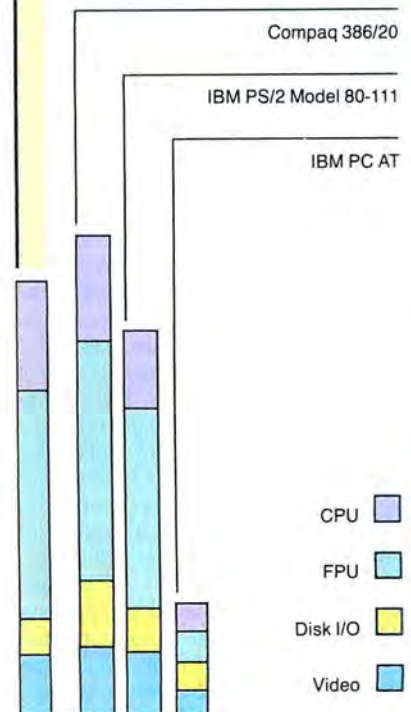

N/A=Not supported by graphics adapter.
¹ All times are in seconds. Figures were generated using the 8088/8086 and 80386 versions (1, 1) of Small-C.
² The errors for Floating Point indicate the difference between expected and actual values, correct to 10 digits or rounded to 2 digits.
³ Times reported by the Hard Seek and DOS Seek are for multiple seek operations (number of seeks performed currently set to 100).
⁴ Read and write times for File I/O are in seconds per 64K bytes.
⁵ For the Livermore Loops and Dhrystone tests only, higher numbers mean faster performance.

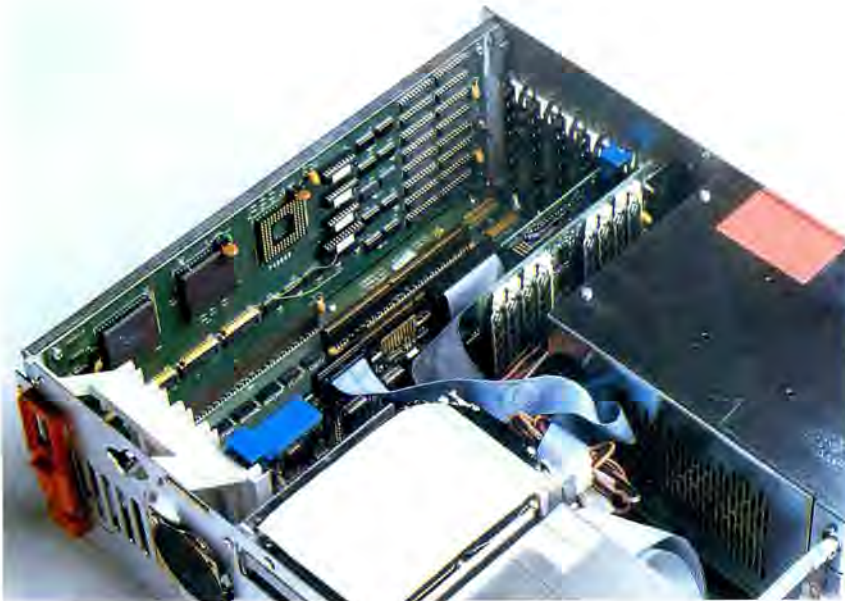

Photo 1: The CPU card is visible in the upper left corner. The card contains the 80386, a socket for an 80387 coprocessor, the 82385, and the SRAM cache chips.

that's more work than it takes to open a PS/2, which is your first hint of just how different the two systems are.

You get the real message when the cover's off. This is not a PS/2 on the inside.

First, forget the PS/2's single motherboard, its slide-on disk connectors, and the nylon snap fasteners that make the IBM machines easy to take apart and reassemble. The 5000 MC is built with traditional PC engineering, with cables snaking everywhere and lots of small screws holding the whole thing together.

Look closer, and the design differences get bigger.

The motherboard is actually only one-third of the heart of the system. It does not contain any of the major processing elements. Instead, all those elements, including the 80386, the 80387 socket, the 82385, and the cache itself, are on a removable CPU card that connects to a proprietary 32-bit slot on the far left side of the system (see photo 1). That board alone contains 32 chips, not counting the 16 SRAM chips. The 80387 socket also has the extra pins to support a Weitek coprocessor, but a Tandy spokesperson said that Tandy does not currently sell the Weitek coprocessor for the 5000 MC.

The system's memory is on yet another board, a Tandy memory-expansion adapter that plugs into another proprietary 32-bit slot on the right side of the motherboard next to the power supply. That board can hold eight single in-line memory modules. In my unit, it had

eight 256K-byte SIMMs, giving the system its standard 2 megabytes of memory.

There is a second proprietary 32-bit slot next to this one that can hold another memory-expansion adapter, so you can ramp up memory to 4 megabytes with 256K-byte SIMMs. While Tandy does not currently offer 1-megabyte SIMMs, a Tandy spokesperson said that it plans to do so in the near future. When these larger SIMMs are available, you'll be able to put up to 16 megabytes of memory on the system using these two boards.

Those two slots and the CPU board slot are all dedicated to their particular tasks, and they will not support any other cards. They all use AT-style connectors that look almost fat next to the sleek Micro Channel connectors. Both memory-expansion boards and the main motherboard are made by Tandy.

The five Micro Channel-compatible slots are on the main motherboard. Two of them are 32-bit Micro Channel-compatible slots, while the other three are 16-bit slots. One of the 16-bit slots includes the special high-speed video connector that you'll also find on a PS/2.

The motherboard supports the CPU board, memory board(s), and expansion slots, as well as all the external connectors, with a whopping 150-plus chips. That's more chips than I have seen on any other 80386-based system's motherboard. The motherboard is also oddly shaped, like an L with an extra bit hanging from the junction of the two sides.

The motherboard in my unit was a

Rev. A model, and it showed its youth. I counted 25 wire traces, including several that were over a foot long, that marked circuit design changes.

The motherboard does the bulk of the work of supporting the Micro Channel-style bus with the five-chip Intel Micro Channel chip set. It also contains the ROM BIOS, which is Phoenix's 80386 Advanced ROM BIOS version 1.01.02. Like most high-speed 80386 systems, the 5000 MC copies the ROM BIOS into RAM at boot time for faster access.

Finally, in total defiance of the PS/2 autoconfiguration philosophy, the motherboard contains two banks of eight DIP switches each and eight jumpers. The DIP switches and some of the jumpers control the system's memory settings, and you have to adjust them if you add more memory on one of Tandy's memory-expansion adapters.

Diverging Design

Of course, it's not always bad to be different from the PS/2s. Most PS/2s have room for only one hard disk drive. The 5000 MC, on the other hand, has one 3½-inch half-height drive area and a 5¼-inch drive bay that can hold either one full-height drive or two half-height drives.

In my unit, the 3½-inch area held an 80-megabyte hard disk drive from Rigidyne, a subsidiary of Control Data Corp. An Adaptec ST-506 controller in one of the expansion slots manages that drive. Tandy claims an average access time of 16 milliseconds for the drive, but, based on its performance on BYTE's disk tests, either it or the controller is really falling down on the job. Based on what I know of CDC drives, my guess is that the Adaptec controller is guilty, but I could not confirm that guess.

Tandy also offers a wealth of options to go into the drive areas, including hard disk drives of up to 344 megabytes, several models of tape drives, and 5¼-inch floppy disk drives.

Skin Deep

When you put the 5000 MC back together and turn it on, you can forget the engineering inside and pretend again that it's a PS/2.

Its 101-key keyboard follows the IBM Enhanced layout. The keyboard has a very light, springy touch, with a good audible keyclick.

Tandy included its VGM-300 analog color monitor with the review unit. The display was very crisp and clear, although its standard font is a bit unusual.

continued

Affordable Large Format Plotting Starting at \$1695.*

A-E
\$2695.
(sugg. ret. \$2995.)

A-D
\$2295.
(sugg. ret. \$2695.)



***\$1695—Model 3610 C/D**
(not shown)
Same style as 3600 A-D
Handles C & D size media

Features that say value ...

Economical: \$1,000 less than other large format plotters.

Compatible: Operates with all popular CAD software supporting DM/PL.[™]

Multiple Media Sizes as small as 8½" x 11" or as large as 36" x 48" eliminates the need for a second plotter.

Practical speed you can really use: 10" per second assures good drawing throughput while optimizing the speed at which most plotter pens can draw without skipping.

Repeatability and Resolution: .004 assures quality suitable for the most demanding applications including PCB artwork.

Vacuum Paper Hold Down guarantees perfect registration.

Unique: X&Y rescaling allows calibration to one part in 10,000. Ideal for applications where scale is critical.

CALL NOW AND WE'LL SEND YOU
A FREE SAMPLE PLOT.

(415) 490-8380 Fax (415) 490-3906

Dealer inquiries invited.

ZERICON

40491 Encyclopedia Circle
Fremont, California 94538

Made in USA DM/PL is a trademark of Houston Instrument

Subscription Problems?



We want to help!

*If you have a problem with your **BYTE** subscription, write us with the details. We'll do our best to set it right. But we must have the name, address, and zip of the subscription (new and old address, if it's a change of address). If the problem involves a payment, be sure to include copies of the credit card statement, or front and back of cancelled checks. Include a "business hours" phone number if possible.*

BYTE

Subscriber Service
P.O. Box 7643
Teaneck, NJ 07666-9866



While you're looking at the monitor you can't help but notice a few things on the front of the unit. One is the big FCC Class A sticker that proudly proclaims the 5000 MC to be a "business computer." Just above it is a keylock that locks the case, not the keyboard. More interesting are the reset and power switches that are on the left and right sides, respectively. The red reset switch is recessed so that you are not likely to push it accidentally.

The oddly shaped, green power switch is another matter. It is only half an inch to the right of the 3½-inch floppy disk drive, so it is just aching for an accidental push. It is also one of the most peculiar pieces of engineering I have seen in a while: Inside, it proves to be the tip of a 9-inch bar of the same green plastic that stretches from the front of the unit to a mechanical switch on the rear of the power supply at the back of the unit. A thin cable snakes through the bar from the motherboard to the tiny indicator light in the tip of the switch. Cute as the switch is, it's dangerous to put a power switch that looks suspiciously like an eject button right next to a floppy disk drive, and Tandy should move it in future systems.

The Soft Stuff

The only standard software is Tandy's reference disk. This disk contains programs that autoconfigure the system, do low-level disk formats, give information about power-on self test (POST) error messages, and let you access a few of the system's more unusual features.

These features include passwords for power-on and keyboard usage, as well as for the 5000 MC's use as a network server. You can also set both the keyboard's repeat rate and its speed of responding to key depressions to a faster speed than normal.

One common software feature of most 80386-based systems that the 5000 MC lacks is the ability to set the CPU to a slower compatibility speed. A Tandy spokesperson said that the 5000 MC is based on the IBM PS/2 Model 80, and that it does not include a way to slow the CPU because the Model 80 does not. I had no problem with my copy-protected Lotus 1-2-3 system disk, which often requires a slower speed when loading the program, but the lack of this ability could be a problem for some older programs.

The Tandy 5000 MC Installation and Operation Manual explains all the functions of the reference disk software. It's a small, 42-page manual, but it is readable, includes an index, and takes you

from unpacking through memory-configuration DIP switch settings.

Of course, sometimes things go wrong that you can't solve with any amount of documentation. That's when a company's technical-support system comes into play.

If you have questions, you can call any local Tandy computer center or computer service and support center. I tried a few of the ones in my area, but because the 5000 MC is just barely shipping now, they really couldn't help me with anything specific to its Micro Channel-compatible features. They were, however, helpful with a few of the usual MS-DOS problems that I threw at them.

A 1-year parts-and-labor warranty comes with the 5000 MC. While Tandy will repair your unit only at one of its roughly 155 service and support centers, you can take the system to any Tandy store, even a Radio Shack, and the company will get the unit to and from the service center at no charge to you.

You can also pay an additional fee for on-site service during that first year. The price depends on what you've got on your unit and how close you are to one of Tandy's service and support centers. For example, if you're within 50 miles of a center and you have a 40-megabyte hard disk drive in your 5000 MC, the first year of on-site service costs \$330.

Tandy also sells additional years of service, either on-site or carry-in, for fees that, again, depend on your system's configuration and your distance from a service center.

Do You Need a PS/2?

All engineering complaints aside, the 5000 MC is a reasonable Micro Channel-compatible alternative to IBM's PS/2 machines. It's a first-generation Micro Channel clone, so you have to expect some rough spots, and there are bound to be some incompatibilities that my testing did not uncover. Still, the 5000 MC is a good first step, and Tandy has already proved that it is going to be a player in the PC world for some time.

The big question is whether you're content to stick with the AT-style bus, or if you want to move to the Micro Channel. If you've decided that the Micro Channel bus is for you, the 5000 MC offers an interesting alternative that is both cheaper and faster than the comparable IBM 20-MHz 80386-based PS/2s. ■

Mark L. Van Name is a freelance writer and computer consultant living in Durham, North Carolina. He can be reached on BIX c/o "editors."

HARD DRIVES



Never a Surchage for Visa or MasterCard Orders

30 Mb

Complete PC/XT KIT includes Seagate ST238R drive, controller, cables, How-To manual & mounting hardware.

GREAT VALUE!

\$269

65 Mb ST277R

40ms access · Half Height
Autoparking heads

Includes drive, mounting hardware & "Disk Manager" partitioning software.

\$379

This drive requires an RLL controller.



FACTORY-TRAINED TECHNICIANS are on hand to answer your questions!



40 Mb ST251

Includes ST251 drive, AT mounting hardware, How-To manual & "Disk Manager" partitioning software.

\$329

Also available for XT.

40 Mb ST251 PC/XT Kit \$389

Includes drive, controller, cables, How-To manual, mounting hardware & partitioning software.

High Speed

Seagate ST251-1 40 Mb

Half Height · 28ms access time
· Available for XT or AT

\$399 IT'S FAST!

Includes drive, AT mounting hardware & "Disk Manager" partitioning software.

ON SALE! 80 Mb

ST4096

Full Height, 28ms access time.
Available for XT or AT.

Includes drive, AT mounting hardware & "Disk Manager" partitioning software.

Call for Lowest Price!



We carry the entire **Seagate** product line including 3.5" drives!

Card Drive™ Hard Cards

Card Drive 20S 40ms \$319
Card Drive 30S 40ms \$349
Card Drive 50S 40ms \$489

- Available for most **Tandy** models
- Super easy installation & setup
- **ONE YEAR Warranty**
- Auto park heads

These Card Drives use quality Seagate Drives

20 Mb ST225 KIT

This complete PC/XT KIT includes the Seagate ST225 drive, controller, cables, How-To manual & mounting hardware.

Half height · 65ms.

Also available for AT.

SPECIAL! \$244

30 Day "WorryFree" Guarantee

If for any reason, you are not completely satisfied with any product, simply return it for a prompt and courteous refund!

Hours: 8am to 7pm
Monday - Friday,
12pm to 5pm Sat.
MST

All products include our ONE YEAR Warranty and our 30Day "Worry-Free" Guarantee!

HARD DRIVES International
An IDN Company

To Order:
Call Toll Free

(800) 234-DISK

International Orders: (602) 784-1038

Toll Free Customer Service: (800) 234-5197

Toll Free Order Status: (800) 234-5197

TELEX: 405765 FAX: (602) 829-9193



1208 E. Broadway Rd. #110 · Tempe, AZ 85282 (602) 784-1038

Prices and availability subject to change without notice. All items are NEW. 5% surcharge for American Express and COD orders. P.O.'s accepted NET 20 - subject to 9% surcharge. Add \$20 shipping for EXPRESS APO/FPO orders. 30 Day Guarantee conditions: shipping & handling charge is not refundable; product must be undamaged and in original condition. BYT0288

BEST



NEW MINI PORTABLE BEST-286 LCD

- 10 MHZ 0 WAIT (12 MHZ Option)
- 512 K RAM
- 1.2 M. Floppy Drive
- 30 MB Hard Disk (Seagate 138 28ms)
- 200 W DC Fan Power Supply
- Serial & Parallel
- Non-Glare LCD Screen
- Super Twist
- Built-In Back Light
- 640 x 200 Dots
- Weight 22 lbs
- Padded Soft Carry Bag
- Dimension 16" x 8" x 9"

\$1600



VTI-33 SYSTEM

- 8088-2 10 MHz
- 640 K RAM**
- 2 360K Floppy Drive
- Serial, Parallel Port
- Clock, Calendar
- AT Style Keyboard
- Build in Mono/Color Graphic
- MONO MONITOR**
- MS-DOS 3.3, GW Basic

\$749

COLOR SYSTEM \$919



BEST-286 PORTABLE

- 10 MHZ (12 MHZ Optional)
- 512 K RAM
- One 1.2 MB Floppy Drive
- 7 Expansion Slots
- 200 W DC Fan Power Supply
- 9" Dual Amber Screen
- Mono or Color Graphic Card
- Serial & Parallel Port
- 84 Key Soft Tough Key Board

\$1115

BEST-88 PORTABLE \$845

Complete 386 SYSTEM

- 80386-20 MHz CPU
- Support 80287, 80387 & WEITEK processor
- Six 16 Bit, Two 8 Bit BUS
- 1 MB RAM (Expandable 2,4,8 MB on board), 32 Bit
- RAM Architecture (Interleaved Page Mode)
- AMI Bios
- Realtime Clock/Calendar
- 1.2 MB Floppy Drive
- Fast 1 to 1 Interleaved Hard Disk Controller
- VGA Adapter & VGA Monitor
- 66 MB Hard Drive (21 ms) (Toshiba)
- 101 Enhanced Keyboard
- Vertical Case
- MS-DOS 3.3 GW Basic
- 1 Year Warranty
- Support: NOVELL/3COM/PC NET/LanLink/OS/2

\$2990



Same Day Shipping

VTI-55 SYSTEM

- 80286 8/12 MHz
- 640K-120 ns
- 1.2 MB Floppy Drive
- 30 MB** Hard Disk Seagate 138 (28 ms) with NCL Controller
- 2 Serial 1 Parallel
- Clock Calendar
- 101 Enhance Keyboard
- ATI EGA Wonder Card
- EGA MONITOR**
- MS-DOS 3.3, GW Basic

\$1699

MONO SYSTEM \$1399

286 BABY MOTHER BOARD

- 10 MHZ \$265
- 12 MHZ \$295
- Mono Monitor \$79
- Fujitsu 101 Enhance Keyboard \$45
- EGA PLUS 640 x 480 (Paradise Compatible) \$139

PORTABLE CASE

- 9" Dual Amber Monitor \$359
- 200 W Power Supply

LCD CASE

- 640 x 200 Dots \$549

CALL FOR QUANTITY PRICE

BEST

COMPUTER INC.
5017 Telegraph Road
Los Angeles, CA 90022

Tel: (213) 265-0900

Tech: (213) 265-0300

Fax: (213) 265-4234

Toll: **(800)634-7920**

Outside Cal.



Credit Card Purchase Subject to Service Charge.

Circle 34 on Reader Service Card (DEALERS: 35)

MON - SAT 9:00 - 6:00 PACIFIC TIME

PRICE & SPEC. ARE SUBJECT TO CHANGE WITHOUT NOTICE



Three Assemblers for MS-DOS

TASM and OPTASM challenge the long-dominant MASM

Michael Blaszcak

Programmers have long known that a computer's native assembly language is the best choice for the fastest code. Microsoft's Macro Assembler, or MASM (\$150), has been the definitive assembler for IBM PCs. Now there are two challengers: Borland's Turbo Assembler, or TASM (\$150), and SLR Systems' OPTASM, for optimizing assembler (\$125). Each of these three assemblers has unique strengths. MASM is the one the others imitate, and it's the only one that supports OS/2 development. TASM comes closest to matching MASM on a feature-by-feature basis, runs faster, and bends over backward to make programming in assembly language easier. OPTASM runs faster yet and can optimize certain troublesome assembly language constructs. They're all worthy tools—I used each to assemble and link working versions of three programs that comprise thousands of lines of code. In this review, I'll try to help you figure out which assembler best suits your needs.

An assembly language development system includes more than just an assembler. You've got to have a linker, too, and you'd like to have a debugger, a librarian, a make facility, and comprehensive documentation. Assembly language programming is tricky, and a good debugger is worth its weight in gold—especially when you're interfacing assembly with a high-level language.

Both MASM and TASM come with

top-notch symbolic debuggers that enable you to view and manipulate your program in terms of source-level symbols and labels, as well as full complements of other support tools. OPTASM is a bare-bones package by comparison. There's no debugger or linker, and you have to spend an extra \$50 to get the optional librarian. SLR Systems does, however, plan to provide more tools in a forthcoming release of OPTASM. See table 1 for a comparison of the features that the three packages offer.

Microsoft's MASM

MASM has evolved considerably during its long life (long by microcomputing standards, that is). MASM 5.1 is the newest version of the product. The package includes the OS/2-capable MASM assembler; CodeView, Microsoft's full-screen symbolic debugger; and the Microsoft linker, librarian, text editor, and make tool.

MASM comes with ample documentation. A reference manual describes the assembler itself, and a particularly useful update outlines the differences between the current MASM and its previous incarnations. A utilities manual details the use of CodeView and the other tools supplied with MASM. The Mixed Language Programming Guide tells you how to interface assembly modules with Microsoft C, Pascal, FORTRAN, and BASIC programs. Microsoft also includes a 148-page reference booklet that enumerates the instruction set, discusses each instruction's side effects, and notes how many clock cycles each instruction consumes.

The quality of the documentation is generally quite good, but I have a few complaints. The manuals are full of examples, but they're usually fragmentary—few are complete and ready to run. The descriptions of instructions that have a rich variety of addressing modes, like MOV and JMP, get short shrift; there's no elaboration on how to declare labels or

data to be addressed by each mode. There is a finished program included with the package—SHOWR.ASM, a file-listing tool—but none of the documents mentions it. In some cases I thought the documentation failed to describe an important technique. The Mixed Language Programming Guide, for example, doesn't tell you how to define data areas and variables in an assembly module for later reference in a high-level-language program. And while the discussion of the LES and LDS instructions plainly shows how to use them to load a doubleword (representing a far pointer) from memory into a pair of registers, it doesn't help you figure out how to set up a doubleword in memory for use in this context.

Putting MASM to Work

MASM was the slowest of the three assemblers. TASM was about twice as fast, and OPTASM about three times as fast (see tables 2, 3, and 4). And MASM was the fussiest—that is, it complained the most. MASM uses a two-pass method to assemble a module. On the first pass, it reads the source file and generates code. On the second pass, it rereads the source file and works on the code it produced to resolve the addresses of symbols and the sizes of op codes.

That's a good strategy, but MASM runs into some problems. For example, here's a line from MS-Kermit, one of the three test programs I used:

```
mov bx,seg serdum
```

This instruction moves the segment part of the address of serdum, a forward reference to a label. MASM's second pass produced a so-called "phase error" that, after some head-scratching, I eventually resolved by expressing the value I wanted to load into the BX register in a different and less mnemonic way:

```
mov bx,code
```

continued

Table 1: A list of MASM, TASM, and OPTASM features.

	MASM	TASM	OPTASM
Installation program	Yes	Yes	No
Macros	Yes	Yes	Yes
Optimization	No	Some	Yes
Simplified segments	Yes	Yes	Yes
Warning level	Three levels	All switchable	On/off
Editor	Yes	No	No
OS/2-compatible	Yes	No	No
Tutorial	No	Yes	No
80386/80387 support	Yes	Yes	No
Local labels in PROC	No	Yes	Yes
Microsoft HLL interface	Yes	Yes	No
Debugger	Yes	Yes	No
Linker	Yes	Yes	No
Overlay linker	Yes	No	No
Librarian	Yes	Yes	No
.OBJ utilities	None	One	None
.EXE utilities	Three	No	No
MAKE utility	Yes	Yes	Yes ¹
Cross reference	Yes	Yes	Yes ²
On-line help	No	No	Yes
On-disk examples	One	Many	Two ³

¹ OPTASM's MAKE utility is nonstandard and integrated with the assembler.
² OPTASM's CREF utility is integral to the assembler.
³ One of OPTASM's two example files highlights the problems with MASM solved by OPTASM.

Table 2: Assembly time for NJRAMD, a RAM disk program.

	Assembly time (seconds)	.OBJ size (bytes)	.SYS size (bytes)
OPTASM	1.7	3758	1897
TASM	2.6	4673	1899
MASM	5.6	4379	1899

Table 3: Assembly time for MS-Kermit.

	Assembly time (seconds)	.OBJ size (bytes)	.EXE size (bytes)
OPTASM	45.4	101,581	86,032
TASM	67.6	171,336	86,157
MASM	165.7	133,780	86,160

Table 4: Assembly time for the Greenleaf communications library.

	Assembly time (seconds)	.OBJ size (bytes)
OPTASM	26.9	5522
TASM	51.6	8058
MASM	81.7	6122

The message associated with the phase error wasn't too helpful, as it occurred several lines after the instruction in question. In the end I had to use MASM's /D command-line option to produce a first-pass listing, then study that for a while to figure out what was happening.

MASM will also pad your code with extra NOP instructions in a variety of situations. This happens when you use a JMP instruction to reach a label that lies within a 128-byte range, or when, as shown in listing 1, you use a test instruction with a forward reference and immediate data.

One of the biggest improvements in this version of MASM is the support for mixed-language programming. It's always tough to remember the protocols you need to follow to build assembly subroutines that you can call from C or Pascal. MASM now provides new simplified segment declaration directives and extensions of standard directives that greatly simplify the proper declaration of segments, groups, and public labels.

Support for the 80386 processor is another major improvement. With the .386 directive, you can use MASM to create DOS programs that will take advantage of the extra registers, addressing modes, and instructions of the 80386.

Finally, MASM and LINK are now dual-mode executables that will run under both DOS and OS/2. They can be used to create other dual-mode programs or to create programs that exploit the protected modes of the 80286 and 80386.

The MASM Toolkit

Much has been said and written about CodeView—it's an excellent debugger—so I'll just mention a couple of favorite features. I'm particularly impressed by its ability to view structured data, following pointers as necessary. CodeView's support for the Intel numeric coprocessors is another strong point—you can dump the status of the coprocessor to the screen during debugging. That, in conjunction with MASM's ability to assemble all the special math op codes, has saved me a great deal of trouble on numerically intensive projects. CodeView can use expanded memory to keep symbolic information out of the way of the executing program. Serious professional users may want to consider buying a hardware debugger, but for my purposes CodeView is entirely sufficient.

Microsoft's linker is slower than TLINK, the Borland linker, but provides good support for program overlays. It's relatively straightforward to create overlay sections. You do need an overlay han-

REVIEW
THREE ASSEMBLERS FOR MS-DOS

	Microsoft Macro Assembler 5.1	Borland Turbo Assembler 1.0	OPTASM 1.5
Type	Macro-based assembler	Macro-based assembler	Optimizing macro-based assembler
Company	Microsoft Corp. 16011 Northeast 36th Way P.O. Box 97017 Redmond, WA 98073 (206) 882-8088	Borland International 1800 Green Hills Rd. P.O. Box 660001 Scotts Valley, CA 95066 (800) 543-7543 (408) 438-8400	SLR Systems 1622 North Main St. Butler, PA 16001 (412) 282-0864
Format	Four double-sided, double-density 5¼-inch floppy disks	Three double-sided, double-density 5¼-inch floppy disks	Three double-sided, double-density 5¼-inch floppy disks
Language	C	C	Assembly
Hardware Needed	IBM PC or compatible with 128K bytes of available memory; a hard disk drive is recommended	IBM PC or compatible with 256K bytes of available memory; a hard disk drive is recommended	IBM PC or compatible with 128K bytes of available memory; a hard disk drive is recommended
Software Needed	PC-DOS or MS-DOS 2.00 or higher	PC-DOS or MS-DOS 2.00 or higher	PC-DOS or MS-DOS 2.00 or higher
Documentation	123-page reference for the MASM 5.1 update; 467-page Programmer's Guide for MASM 5.0; 139-page Mixed Language Programming Guide; 402-page CodeView and Utilities reference; 148-page reference booklet	296-page Reference Guide; 582-page User's Guide	323-page reference for OPTASM; 56-page booklet for OPTLIB
Price	\$150	\$150	\$125 for OPTASM \$50 for OPTLIB
	Inquiry 1055.	Inquiry 1056.	Inquiry 1057.

sembler, but, although none is included with the assembler, you can add the overlay handler from any Microsoft high-level-language run-time library to your executable code at link time.

The Microsoft MAKE program mimics Unix make closely. It's small, so you don't run into trouble executing other tools from within it. It features a well-developed macro facility. And there's a suite of tools—EXEPACK, CVPACK, and EXEMOD—that squeeze executables and modify program headers.

MASM takes some getting used to, but it gets the job done. MASM does have more than its fair share of frustrating quirks and oddities, but it's always considered to be the standard for general-purpose work. And if you're doing OS/2 development, it's the only game in town.

SLR Systems' OPTASM

OPTASM is a lean and mean package aimed squarely at seasoned program-

mers. It comes with one concise reference book that covers all the bases. As the name implies, OPTASM is an optimizing macro assembler. The program makes all the passes needed to resolve addresses of symbols and op-code sizes.

OPTASM can pick the most efficient version of the JMP op code automatically, and it will even expand conditional branches that are out of range into the appropriate instructions to make the jump possible. Given listing 1, for example, OPTASM would rewrite the `jnc` instruction—which specifies a jump to an out-of-range label—like this:

```

        c1c
        jnc     locally
        jmp     nearly
locally:
        REPT   150
        nop
        ENDM
nearly:

```

This frees the programmer from the task of keeping track of ranges when coding conditional jumps. OPTASM also optimizes far jump and far call instructions and provides directives that allow popping and pushing more than one register on a line of code. These optimizations seem trivial, but the net effect is a big saving of effort, particularly when developing larger modules.

The manual provides descriptions of simplified segment declarations that are much clearer than Microsoft's. The manual also takes greater care in explaining the physical loading order of segments in a multisegment program and clearly explains how the ALIGN, COMBINE, and CLASS keywords control the behavior of LINK.

OPTASM is generally compatible with version 5.0 of MASM but omits several features that were added to version 5.1. MASM's enhanced .MODEL directive,

continued

Listing 1: Only TASM handles this code cleanly.

```

; Microsoft and Borland allow the programmer
; to define the high-level language this module
; will be used with. OPTASM does not.

.MODEL small,c
.CODE

; Microsoft and Borland allow the specification
; of high-level-language function parameters
; in the PROC line. OPTASM doesn't.

sample PROC    parm1:word, parm2:word

; Microsoft and Borland permit you to
; declare local variables. OPTASM doesn't.

LOCAL    var1:word,var2:word
mov     ax,35      ; mov 35 into
mov     var1,ax   ; load var1
clc
jnc     faraway   ; We can't conditionally jump to a
                ; label that is more than 128 bytes
                ; away. OPTASM reconstructs this
                ; with functionally equivalent code.
                ; TASM and MASM produce errors.

REPT    150
nop
ENDM

; This construct causes MASM to
; generate a phase error.

faraway:
        test    forwardref,3

; MASM generates an extra NOP here.
; TASM and OPTASM don't.

        mov     cx,messageLen
        ret
sample ENDP
        .DATA
forwardref db    01234h
message    db    "This is a string.",13,10
messageLen equ   this byte - message
        END

```

for example, lets you name the language from which you'll be calling your assembly routine; OPTASM complains about the .MODEL directive in listing 1 for this reason. Nor does OPTASM support MASM's improved PROC and LOCAL directives; PROC declares parameters that the assembly routine expects to find on the stack, and LOCAL declares and symbolically addresses local variables. These incompatibilities aren't a problem if you start a project from scratch with OPTASM, but they'll complicate your life if you're porting code from MASM to OPTASM.

OPTASM comes with an on-line help system that delivers information about the assembler and the Intel op codes. It's

handy, but its 100K-byte memory requirement seems excessive. There's a CONFIG program that you can use to set OPTASM's defaults; alternately, you can use environment variables to achieve the same effect. The MAKE facility is integral with the assembler, not a separate tool. It uses nonstandard make files that aren't compatible with other MAKE programs. There's no debugger, although you can use the /ZD option to get OPTASM to insert line-number information for use in conjunction with CodeView and other debuggers. There's no linker, and the librarian, OPTLIB, costs an extra \$50.

OPTASM's big draws are its speed and the compactness of the code it produces.

No question about it, OPTASM trounces MASM and TASM in both categories. Serious assembly language programmers working on projects that don't require MASM's newest features—for example, the .386 directive and the enhanced .MODEL, PROC, and LOCAL directives—will definitely want to look at this package.

Borland's TASM

Borland's TASM now ships as part of the Borland professional packages. Turbo C 2.0 contains release 1.0 of the assembler and version 2.0 of Borland's linker. Also included are a librarian and several other utilities, as well as the Turbo Debugger. Turbo Pascal 5.0 contains the same programs. You can buy just the assembler and debugger separately for \$150.

Unlike MASM and OPTASM, TASM comes with a strong tutorial on assembly programming that programmers more familiar with languages like Pascal and C will find extremely useful. But I found the reference material skimpy—the discussion of STRUCT and UNION directives, for example, was quite inadequate. And Borland's softbound manuals are troublesome; you can't leave one open to a particular page without using an extra hand or a paperweight. The sample programs, however, are excellent. The distribution disks contain copies of all the examples in the documentation, and there are also three complete utility programs ready to assemble, link, and run.

Borland has gone to great lengths to make TASM compatible with MASM. There are two directives that govern MASM compatibility. The MASM51 directive provides full emulation of version 5.1 of Microsoft's product. And there's even a QUIRKS directive that causes TASM to mimic some of MASM's infamous peculiarities.

The Turbo Debugger matches CodeView feature for feature and, although it doesn't support mice, implements an intuitive point-and-shoot interface. There's a useful Get Info command that maps DOS memory, expanded memory, and any interrupts the target program may have snatched. And if you're debugging 8086 software on an 80386 machine that has 700K bytes of extended memory, you can use the "virtual debugger," TD386, to create a virtual 8086 on which to debug your program. The resulting environment is close to what you get with a hardware debugger.

TASM runs faster than MASM but slower than OPTASM. But—and here's the most important point—TASM alone cleanly assembled everything I fed it. In

a sense, TASM gives you the best of both worlds: MASM compatibility without MASM's glitches.

TASM Extras

Borland has also made an effort to rationalize MASM's syntax. The `.IDEAL` directive invokes "ideal mode." If you use this mode, you trade away MASM compatibility for improved readability—particularly with respect to addressing modes. For example, the MASM construct

```
mov ax,4[bx][si]
```

(which looks like multiplication but isn't) is illegal in TASM's ideal mode, which instead requires the more intelligible

```
mov ax,[4+bx+si]
```

The improvement is considerable and will certainly help beginners. The benefits of some of the other constructs required by ideal mode are less clear-cut. For example, ideal mode requires that you put names before keywords, so that the MASM construct

```
PROC myproc near
```

becomes

```
myproc PROC near
```

which, in my opinion, isn't a big win.

The nicest thing about ideal mode is that it lets you use the same identifier in more than one structure. There are some drawbacks. Because symbols can't start with a period in ideal mode, you have to relearn certain MASM directives—for example, `.286` and `.XALL` become `P286N` and `%NOMACS`. And unlike MASM, TASM's ideal mode requires you to explicitly quote strings used in conjunction with directives.

The Borland toolkit includes `TLINK`, the linker; `TLIB`, an object-module librarian; `TCREF`, a cross-referencing utility; and `MAKE`. Borland's `MAKE` is slightly more powerful than Microsoft's because it implements predefined macros like `include`, `IF`, and `ENDIF` that improve the programmability of the `MAKE` facility. Borland also includes a wonderful program called `OBJXREF`. It can read a group of object files and list the public names that each one declares, as well as the external labels that each module relies on. Like `OPTASM`, `TASM` doesn't include utilities that manipulate `.EXE` files.

`TASM` is the recommended choice for programmers with little assembly experience. It's geared for use with Turbo C and Turbo Pascal but doesn't require those products. You can create stand-alone applications with `TASM`, and you can interface `TASM` modules to programs written in Microsoft high-level languages without any trouble.

Putting the Packages through Their Paces

To test the packages, I used each to assemble three different sets of assembly language routines: my own `NJRAMD`, a RAM disk program; `MS-Kermit`, a 25,000-line assembly version of the popular communications program; and the Greenleaf communications library. `NJRAMD` makes extensive use of conditional directives and structures; the other two programs include header files that perform lots of symbol equates and define a number of macros.

I ran the tests on an 8-MHz PC's Limited 286 with 640K bytes of memory, using a RAM disk. As the results show, `OPTASM` runs fastest and produces the smallest `.OBJ` files. `TASM` comes in second in terms of speed, and `MASM` takes second place in `.OBJ` size. Most of the code-size differences vanish, though, when you look at the sizes of the linked `.SYS` and `.EXE` files. `OPTASM` writes a highly compact set of `.OBJ` records, but the difference between it and the others in terms of the actual quantity of executable code, while perceptible, is quite small.

While my benchmarks showed `TASM` to be somewhere between `MASM` and `OPTASM` for performance, it offers a nice combination of `MASM` support and `OPTASM`'s assembly language optimization skills. `TASM` provides conditional jump extensions and doesn't trip up on source code that `MASM` is not able to handle.

All three assemblers do the job; none is perfect. Choose the one that's right for you. If you're doing OS/2 development, your choice will obviously be `MASM`. If raw speed is critical, you don't need OS/2 support or guaranteed `MASM` compatibility, and you've got the necessary support tools, use `OPTASM`. My personal favorite is `TASM`. For my money, it's got the best mix of speed, `MASM` compatibility, and overall ease of use. ■

Michael Blaszczyk, a University of Hartford student, provides technical support for NWI of East Hartford, Connecticut. He can be reached on BIX c/o "editors."

A Wealth of Knowledge.

We, the Murphys, believe we can help **peace officers, sales persons, attorneys, editors, social workers, secretaries, personnel managers** and anyone else who deals with or needs to *keep track of a variety of people.*

We've crafted a *personal information manager* that handles mundane yet important tasks such as billing and client tracking easily and efficiently, so you can better use the information you have pertaining to the people important to you.



Easy Billing and Time Keeping. Maintain your time and job records with our program. Invoices and time reports can be created automatically.

Personal Information Management. Organize clients, contacts, phone numbers, etc. Keep extensive notes for each entry (great for callback information and call history). Cross reference the entries with user-definable relationship links.

Print mailing labels/merges, rotary index cards, telephone lists and more.



The REGISTER Program

\$79.95

+ \$2.50 s/h

Available for IBM PC's
MS-DOS 2.0 or better, 512 Kb
30-day money back guarantee



Orders 1-800-548-7465
Information (206) 226-0765
Fax (206) 235-8368



The Murphys

Applied Computing Services

14410 S.E. Petrovitsky Rd., Suite 203, Renton, WA 98058

PROTECTION FROM THE FAMILY THAT MEANS BUSINESS

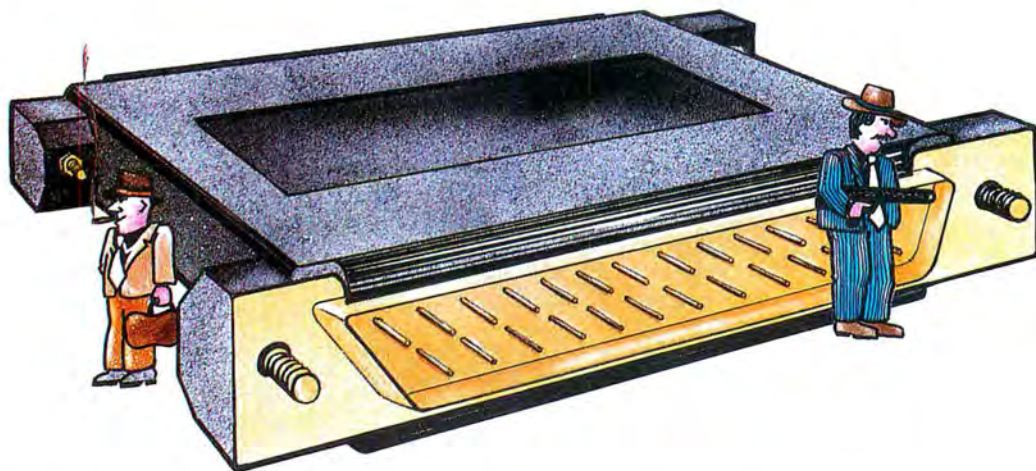

THE PROLOK™ FAMILY.

ROMLOK™ is the intelligent software protection device that attaches to and runs transparently from a computer's parallel port. It allows the user to make unlimited backup copies, and run freely from a hard disk (no installs required). Anything that can be done with unprotected software can be done with ROMLOK—*with one exception*—the free distribution of your program to other users.

Whether You're a Programmer or Not

ROMLOK is the first hardware device that doesn't require programming to get up and running. The ROMLOK protection utility will produce a protected copy of your software in less than 30 seconds.

No Dumb Dongle

ROMLOK has its own microprocessor and memory. ROMLOK memory can store up to 16 bytes of crucial program data. To capitalize on ROMLOK's many unique features, linkable object code is available, so you can customize your application.

From the Protection Originator

Vault offers a complete line of protection and security products. From inexpensive SURELOK™ protection, to

patented disk based PROLOK™ protection, to the new ROMLOK-P™, and the even more secure ROMLOK-S™ (a non-repeating encryption tool), Vault has the answer to your protection needs. *Call the Originator, not the Imitator.*



Contact VAULT CORPORATION at
2192 Anchor Court, Unit C, Newbury Park, CA 91320
805-499-5978
Telex: 805-499-5396 VAULT US • Fax: 805-498-6046
800-445-0193 (Nationwide) • 800-821-8638 (California)

ROMLOK™

Copyright ©1988 Vault Corporation



Full Impact

New bells and whistles in Ashton-Tate's spreadsheet for the Mac

Diana Gabaldon

Full Impact is not, as you might think, the latest Dirty Harry film. It's Ashton-Tate's Macintosh spreadsheet package, the latest entry in a line of Mac office software, meant for those who like their balance sheets with bells on.

Full Impact sells for \$395 and runs on a Mac Plus, SE, or II with 1 megabyte of memory and two 800K-byte floppy disk drives, but to use it effectively you need 2 megabytes of memory, one floppy disk drive, and a hard disk drive. It works with System 4.1 and Finder 5.5 or higher.

Like FullWrite, Ashton-Tate's word processor/desktop publisher reviewed in the November 1988 BYTE, Full Impact is heavily loaded with presentation-graphics features and is excellent in some performance areas.

One of the most striking features is Full Impact's drawing capability, which allows you to draw shapes, add graphs and charts to them, and store everything with the spreadsheet in a single file. While Microsoft's Excel allows you to add charts and text to a spreadsheet, its drawing capability is not as flexible, and you must store graphics separately from the spreadsheet.

Full Impact's drawing display is actually a "layer" that lies over the spreadsheet itself. The layer containing the graphics can be transparent or opaque, letting the spreadsheet show through the

view of charts and graphics or blocking it out. Graphics elements can also be easily adjusted to overlay each other in various combinations; in other words, you can place an oval on top of a rectangle, then move the oval behind the rectangle, then move it up front again. In addition to ovals and rectangles, you can draw rounded-corner rectangles, lines, underlines and outlines for single cells or blocks, and all the standard types of charts: pie, bar, stacked-bar, line, area, scatter, and high-low-close.

Easy Interface

Aside from its presentation features, Full Impact's major attraction is its ease of use. Instead of the usual spreadsheet Worksheet Global...Quit menu across the top of the screen, Full Impact, taking full advantage of the Mac interface, has an icon bar in which icons represent some of the more commonly used features, such as "fill down," "fill across," and "define range." The icon bar is really two alternating icon bars, which provide a wide range of functions. You can also customize the bar to allow for using your favorite functions via icon.

This interface is another major difference between Full Impact and Excel, which has the standard type of spreadsheet menu. While Excel also allows you to add graphics to a spreadsheet, they are shown in separate, smaller windows that overlay the spreadsheet. In Full Impact, the graphics elements are shown in the spreadsheet itself, in the actual positions where they will appear.

You can add text to a spreadsheet just as easily as graphics. Define an area where you want the text to go, and once defined, this area can be moved, resized, or pasted wherever you want it, no matter what text it contains. And within the text window, you have word-wrapped text, with the usual Mac fonts, type sizes, and type styles available.

You can reduce and enlarge a spreadsheet to preview a formatted page, but

this is a rather tedious business, as you must keep reducing over and over, a bit at a time, to arrive at a view of a whole page. Page formatting is supported to the extent of standard margins, headers, and footers, but not much more.

One difficulty in running any spreadsheet package on a Mac is, of course, the restricted screen area available. By the time you take three lines off the top of the screen for the main menu bar, icon bar, and data-entry bar, and another line off the bottom and a space at each side for neat appearance, you're left with the electronic equivalent of a 3- by 5-inch index card to work in. Full Impact remedies this limitation to some extent by allowing you to have up to eight views of a spreadsheet open concurrently. This is the equivalent of having the spreadsheet visible in eight separate windows, except that the windows overlay each other, rather than being tiled.

Full Impact provides one refinement in spacing. While most spreadsheets let you adjust column width, this one also lets you adjust row height, so you can expand any cell in both dimensions.

Full Functionality

Full Impact has all the standard spreadsheet functions and a few extras, as well. You can, of course, enter date and time as ID markers or "time stamps." You can also use them as values, to calculate items such as payment dates or peak sales periods. There is a NUM2C function that converts a numeric value to a text string so that you can insert it in a macro that uses text and numbers together. As a nice touch, you can select discontinuous areas of the spreadsheet. Also, Full Impact allows you to cut and paste spreadsheet areas to the Clipboard for easy transfer, while Excel does not.

Functions include Math, Logic, String, Database, Statistics, Time, and Spreadsheet submenus. The Math submenu includes trigonometric and log

continued

Full Impact 1.0

Type

Spreadsheet

Company

Ashton-Tate
20101 Hamilton Ave.
Torrance, CA 90502
(213) 329-8000

Format

Four 3½-inch 800K-byte floppy disks

Hardware Needed

Mac Plus, SE, or II with a minimum of 1 megabyte of memory (2 megabytes recommended) and two 800K-byte floppy disk drives

Software Needed

System 4.1 and Finder 5.5 or higher

Language

C

Documentation

180-page user's manual

Price

\$395

Inquiry 1066.

functions as well as all the standard math functions such as exponentiation and square root. The Spreadsheet submenu has functions that locate values in the spreadsheet and evaluate certain attributes. The Horizontal Index Lookup, for example, searches from left to right across the first row of a specified range until it finds a specified value. Then it gives the count of the cells searched.

The software also supports a sophisticated macro language. You can use Boolean logic to set conditions in macros, and you can construct "smart" macros—those capable of taking alternative actions, depending on the conditions encountered. Macros can also pass parameters to functions called by the macro. There is an Undo function that can be called from a macro and elsewhere in a spreadsheet, but Undo cannot be recorded as part of a macro.

You can set the recalculation for manual, regular automatic recalculation, and automatic recalculation at intervals you choose. You can also set an auto-save option, which automatically saves the spreadsheet and data at intervals you specify. You can protect individual cells and ranges against accidental change, but unlike Excel, Full Impact doesn't let you build a protected spreadsheet. In Excel, you can lock some cells and leave others

"open" for change. Both programs support password protection for files.

Flexible Operation

There is more than one way to do most things in Full Impact. For example, you can enter information in cells using the keyboard, the icon bar, or a combination of both. I found the icon bar very annoying to start with, but once I got used to it, using the icon bar was often faster than using the keyboard. I still prefer to enter formulas using the keyboard, but some functions, such as range definition, work very nicely with icons. This flexibility adds greatly to the package's friendliness and ease of use.

You can import information into a spreadsheet from other software, such as Microsoft Multiplan or Excel, or even from such DOS programs as Lotus 1-2-3 and the various versions of dBASE—provided you have suitable communications hardware and software for linking your DOS machine with your Mac. I tried transferring a small dBASE III file, using LapLink Mac, and found that it worked fine, although the transfer was slow. It also successfully imported a file (but not the macros) created by Lotus 1-2-3 version 1.0.

Imported spreadsheets are limited to 2048 rows by 256 columns. When you import records from a database such as dBASE, this limitation means that you can import a maximum of 2047 records, since the field names from the database file occupy the first row. This size limitation is one of the most important differences between Full Impact and Excel. While a Full Impact spreadsheet can have no more than 2048 rows (whether imported or generated by Full Impact), Excel allows more than 16,000 rows.

As for export, you can export Full Impact spreadsheet data to other formats, including Lotus 1-2-3 version 1.0/1a/2.0, but you can export the graphics part of a spreadsheet only via the Clipboard, which essentially means you cannot export to a DOS system.

Spreadsheets, in general, don't make particularly good database managers, and Full Impact is no exception. It's necessary to define and name a range both for the actual data cells in the database and for a separately constructed range of criteria cells and to define (though not to name) an output range to which the output records may be written. If you put the output range too close to cells that already contain data, the existing data will be overwritten by the selected records. It took me three tries to get the example given in the manual to retrieve records

from a sample database correctly; the error message kept telling me I had not defined a range correctly but wouldn't tell me which range.

On the other hand, you can do a few special things with the database capabilities of Full Impact. You can, for example, specify more than one criterion for a single cell, such as selecting records for cars with a price greater than \$20,000 and cars with a price less than or equal to \$17,000. Likewise, you can define your output range as a single cell, and Full Impact will automatically adjust the range to accommodate all selected records. However, if these records extend over adjacent cells containing data, the adjacent cells will still be overwritten. So for actual retrieval of selected records, Full Impact performs similarly to Excel on files of similar size—but Excel handles much larger files.

Getting Help

The documentation is very polished and generally well-written and well-organized. The on-line help is good. This, too, has been "Mac-intized"; you get help by transforming the mouse pointer into a "help" pointer by pressing Command-?, then pointing to the icon you require help with before clicking with the help pointer.

As with all other Ashton-Tate products, a new Full Impact user is allowed one phone call prior to registration. Thereafter, Full Impact comes with Ashton-Tate's standard 90-day free support package. Support after 90 days must be paid for, at the rate of \$50 for 15 calls in a year. A monthly newsletter, "Random Lines," is available at \$18 per year, and additional support is available via the Ashton-Tate Forum on CompuServe.

Support calls are not toll-free but are answered from 6 a.m. to 4:30 p.m., Pacific Time. I called twice in the course of writing this review, and after 15 minutes of listening to Jim Croce music, I gave up and left a message to be called back. My call was returned within the stipulated 24 hours, and once I had a technician on the line, I found him friendly, helpful, and knowledgeable.

Impact on Performance

The most serious drawback to Full Impact is a defect it shares with FullWrite: It's a memory hog. While it theoretically requires only 1 megabyte of memory and two floppy disk drives to run, Full Impact actually needs 2 megabytes and a hard disk drive to run effectively. Even a small (35 by 10) spreadsheet ran out of

continued

NEW
Release

Well, almost everyone prefers MICROSTAT-II



If you like using statistics packages that require a couple of dozen disks and a manual that reads like a Ph.D. dissertation, you probably won't like Microstat-II. On the other hand, if you need an easy-to-use statistics package that lets you start solving problems five minutes after it's installed, Microstat-II is your answer.

Whether you use statistics to support your spreadsheet work and reports, pure research, or anything in between, Microstat-II Rel. 1.5 has the features and performance you demand:

Ease of Use. Microstat-II uses an *intuitive menuing system* for program selection. There is no complex command language to learn or expensive training costs to pay. You'll do more work faster with Microstat-II because it takes fewer key-strokes to accomplish a given task. Fewer keystrokes means faster results and fewer mistakes.

Speed. Microstat-II processes your data up to *eight times faster* than competing packages - even faster with a math chip.

And we gain this speed advantage without any loss of accuracy.

Coverage. Whether you use simple descriptive statistics or Stepwise multiple regression, nonparametrics or ANOVA, we have the procedures you need.

Compatibility. Creating data files is a snap and you can import ASCII, DIF, and dBase files into Microstat-II. Results can be saved as ASCII files for easy incorporation into your reports.

Microstat-II runs on an IBM PC, XT, AT or compatible with 512K of memory, two floppy disks or a hard disk. The package price is \$395.00. If you're still not convinced, try a demo disk for \$19.95 (credited towards purchase).

We are so sure that you'll like Microstat-II, we offer a 30 day money back guarantee. Contact your software dealer or give us a call. (If you already own Microstat-II Rel. 1.0, call for details on free update!)



Ecosoft Inc.

6413 N. College Ave.

Indianapolis, IN 46220

1-800-952-0472 • FAX: 317-251-4604

Trademarks: Microstat-II - Ecosoft Inc. IBM PC, XT, AT - International Business Machines.
Registered Trademarks: IBM - International Business Machines.

ECOSOFT

disk space while inserting and deleting rows, and the Undo function failed to work when managing larger spreadsheets. Consolidating linked spreadsheets also runs you into trouble when you have only 1 megabyte. With more than two or three linked spreadsheets, consolidation slows to an unbearably snail-like pace.

In terms of speed, Full Impact performs all right, but not spectacularly, on small files. On a 1-megabyte machine (I used a Mac SE with a hard disk drive for these tests), though, its virtual memory management really slows things down when working with large files. For example, pasting an identical formula into every cell of a 256 by 2048 spreadsheet could easily take all night.

Full Impact and Excel perform comparably on most small-file operations (see table 1), although Excel loads somewhat more slowly than Full Impact. However, Excel is noticeably faster when handling large files once they are loaded.

I did encounter a small problem running the benchmark tests. While trying to run the Savage test, I had an error message that kept telling me "Invalid right

parenthesis" even though all parentheses were properly paired. It turned out that I had entered the wrong form for one of the functions used in the formula. I used ARCTAN, while Full Impact codes this function as ATAN. However, the error message didn't tell me I had bad syntax or a nonexistent function; it said I had an invalid right parenthesis, which I didn't.

In addition to the 180-page main manual, the Full Impact package contains a plethora of little manuals and instruction booklets, each clearly labeled. A tutorial disk is also included. It takes about 15 minutes and is meant as orientation for a novice spreadsheet user. It provides an introduction to the basic concepts and features of spreadsheet operation, plus a quick look at some interesting features of Full Impact, such as its ability to include graphics and formatted text.

Full Impact is a reasonably powerful spreadsheet package with excellent presentation and graphics features, but it has less file-size capacity than the comparably priced Excel, and this capacity is limited still further by its gluttonous appetite for memory. Its ability to import files produced by other spreadsheet and

Table 1: Benchmark results. Full Impact performed comparably to Excel on the standard BYTE tests.

	Full Impact	Excel
Savage	2:40	2:21
Byte recal	0:17	0:15
Scroll right	0:33	0:34

Note: All times are in minutes:seconds.

database programs is limited, which means it is not really suitable for an office using a variety of spreadsheet programs. My impression of Full Impact is that it is intended for small-to-medium-size offices in which it is the only spreadsheet package; given enough memory, its features and ease of operation make it a good choice in this situation. ■

Diana Gabaldon is the editor of Science Software and an assistant research professor at the Center for Environmental Studies at Arizona State University. She can be reached on BIX c/o "editors."

PROTECT INTELLIGENCE WITH INTELLIGENCE

PROTECH KEYS:

- are totally transparent to the end user
- allow unlimited back up copies
- free up disk drives
- do not interfere with peripheral operations
- are easy to install
- protect software developers' revenues
- provide the highest level of protection available

ProTECH's KEYS provide the highest level of protection because of:

- assembler based routines (not drivers)
- encrypted routines
- physically unique hardware KEYS
- sophisticated software installation advice

THE KEY

The KEY provides effective software protection while insuring customer satisfaction. The KEY is a random response device which is designed for identically reproduced software packages.

SOFTWARE PROTECTION KEYS BY PROTECH

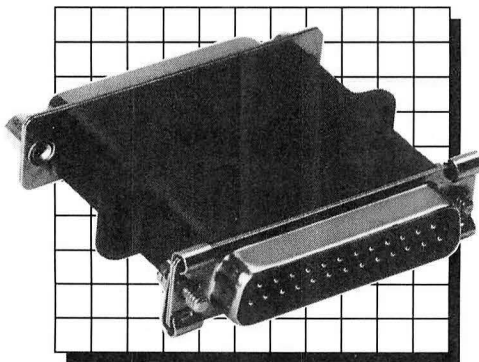

WE HAVE THE KEY TO SOFTWARE COPY PROTECTION

For a demonstration package or additional information, please write or call:

1-800-843-0413

THE MEMORY KEY

The MEMORY KEY is a programmable software protection device. Each byte of memory can be addressed in groups or individually. Possible applications for the MEMORY KEY include:

- modular package control
- serialization
- customization
- access control to PCs

Information stored in the MEMORY KEY can also be altered by your application software in the field. This dynamic writing to the MEMORY KEY opens up unlimited possibilities. Possible applications for the dynamic read/write function include:

- demo control
- software leasing
- updating modules in the field
- any "counter" operation

PROTECH MARKETING, INC.
1804 W. Southern Parkway • Building A-112
Durham, North Carolina 27707
(919) 490-4970 FAX (919) 490-4974

An Anti-Virus Vaccine Plus Seven RAM Resident Productivity Modules For Under \$100 Is Nothing To Sneeze At.

Today's advances in networking and connectivity mean more computers are sharing more information than ever before. That's good news!

But it also means that now, when one PC becomes infected by a virus, thousands of others across the country start sneezing almost immediately. And that's not so good.

The Cure For The Common Virus And More

For virtually any computer user concerned with protecting valuable data from infection, new MultiPlus is just what the doctor ordered.

MultiPlus combines a powerful anti-virus vaccine and seven other RAM resident productivity modules into the most comprehensive desktop management package ever offered.

Constant Data Protection

Because MultiPlus is RAM resident, you never have to worry about letting your guard down against computer mischief and crime. Anytime a virus is detected, MultiPlus automatically flashes an urgent, on-screen alarm and provides an immediate course of action to correct the problem.

With MultiPlus you'll get more value from your system, because you'll be able to take full advantage of bulletin boards and networking without worrying about your data.

The Added Plus Of A Powerful Productivity Tool

MultiPlus is more than just an anti-virus vaccine. It's a full-featured PC desktop management package, designed to enhance user productivity in business, scientific, academic, programming and home computer environments. The program's integrated modules provide:

- Full-featured word processor with a useful typewriter mode
- Database file manager that makes printing mailing labels or 3"x5" cards a snap
- Telephone message center featuring a notepad, mailbox and time/date stamp
- Five different calculators for: scientific, financial, statistical, metric-anglo conversion and programmer computations
- An infinite calendar and 24-hour appointment planner, including a holiday indicator
- PC utilities such as DOS utilities, ASCII table, system information and vaccine status
- An auto-dialer that dials phone numbers and allows you to print out phone directories.

Eight Modules One Low Price

You might easily expect to pay hundreds of dollars for anti-virus protection alone. Yet as a special introductory offer, you'll get all eight MultiPlus modules, including the potent MultiPlus vaccine for only \$99. That's a 50% savings off the regular retail price. This is a limited time offer, so call our toll-free number, or mail in the coupon below, today!



PC, XT, AT and IBM "PS 2" compatible. Requires hard disk, MS-DOS 2.0 or greater and 640K. Network compatible. (IBM and PS 2 are registered trademarks of International Business Machines Corporation). MultiPlus and SunFlex Software are trademarks of SunFlex Software.

Circle 222 on Reader Service Card
(DEALERS: 223)

**\$99 Special
Introductory Offer.**

 **MultiPlus**™

**RAM Resident Professional Desktop
Manager And Anti-Virus Vaccine**

I Want To Take Advantage of Your
Special Introductory Offer:

Please send me _____ copies of MultiPlus at just \$99 each plus \$3.75 shipping per order (\$12 for shipping outside USA and Canada). Georgia residents add local sales tax.

NAME _____

ADDRESS _____

CITY _____ STATE _____

ZIP _____ PHONE _____

Form of Payment: Check Enclosed Ship C.O.D.

Call Toll Free 1-800-633-1524.

Or Mail this order from to:

SunFlex Software
1447 Peachtree Street, N.E./Suite 503/Atlanta, Georgia 30309



MONTGOMERY GRANT

Retail Outlet: Penn Station, Main Concourse
(Beneath Madison Square Garden) NYC, N.Y. 10001

Store Hours: Mon-Fri 8:30am-8pm/Sat-Sun 9:30am-7pm

FOR ORDERS & INFORMATION CALL TOLL FREE

1-800-759-6565

OR WRITE TO:
Montgomery Grant Mail Order Dept.
P.O. Box 58 Brooklyn, NY 11230

FAX NO. 7186923372
TELEX 422132 MGRANT

OUTSIDE USA---CALL
(718)692-0071

FOR CUSTOMER SERVICE
Call Mon-Fri: 9:30am-4:30pm
(718) 692-1148

OPEN 7 DAYS A WEEK FOR ORDERS: Monday-Friday, 9:00am-7:00pm/Saturday & Sunday, 9:30am-6:00pm (EST)

NO SURCHARGE FOR CREDIT CARD ORDERS / WE INVITE CORPORATE & EDUCATIONAL CUSTOMERS
CORPORATE LEASING AVAILABLE

LAPTOPS



AMSTRAD
PPC-640 SD

- 640K
- 720K Floppy Drive
- Built-in 2400 Baud Modem

\$799

- AMSTRAD PPC 640 with Two Drives.....\$899
- NEC MULTISPEED EL.II.....\$1399
- NEC MULTISPEED HD.....\$2179
- TOSHIBA 1000.....\$749
- TOSHIBA 1200 F.....\$1549
- TOSHIBA 1200 H.....\$2199
- TOSHIBA 1200 HB.....\$2399
- TOSHIBA 3100/20.....\$2929
- TOSHIBA 3200.....\$3569
- TOSHIBA 5100.....\$4649
- ZENITH 184 w/ 2 FLOPPYS.....\$1469
- ZENITH 184-2 w/ 20MB.....\$2199
- ZENITH 184-98 w/20MB,Modem.....\$2299
- ZENITH 286 w/20 MB.....\$3299
- ZENITH 286 w/ 40 MB.....\$3969
- SPARK EL.....\$1099
- EPSON EQUITY LT.....\$1099

MODEMS, EXTERNAL DRIVES & ACCESSORIES available for all laptops



EPSON

EPSON EQUITY I+
IBM XT COMPATIBLE PKG.

- 640K RAM w/Clock Calendar
- 360K Drive • Keyboard • Serial & Parallel Ports • 12" High Resolution Monitor • MS DOS/GW Basic

\$799

- Same w/20 MB Hard Drive.....\$1059
- Same w/30 MB Hard Drive.....\$1099
- Same w/40 MB Hard Drive.....\$1199
- Same w/Two 360K Floppies.....\$879



EPSON EQUITY II+
IBM AT COMPATIBLE
HARD DRIVE PACKAGE

- Keyboard • 640K RAM • 80286 Microprocessor • 1.2 MB Floppy Drive • 20 MB Hard Drive • 12" Monitor • MS/DOS/GW Basic

\$1449

- SAME w/30 MB HARD DRIVE.....\$1499
- SAME w/40 MB HARD DRIVE.....\$1599

LOGITECH MOUSE M-7.....\$59.95



EPSON EQUITY III+
IBM AT COMPATIBLE 20 MB
HARD DRIVE PACKAGE

- Keyboard • 80286 Processor • 640K RAM • 6/8/12 MHz • 1.2 MB Floppy Drive • 20 MB Hard Drive • 12" Monitor • 8 Expansion Slots • Serial & Parallel Ports • MS DOS/GW Basic

\$1749

- SAME w/30 MB HARD DRIVE.....\$1799
- SAME w/40 MB HARD DRIVE.....\$1899

NEC PowerMate 1+



IBM AT COMPATIBLE
PACKAGE

- Enhanced Keyboard • 80286 Microprocessor • 12 MHz • 1.2 MB Disk Drive • Serial & Parallel Ports • 12" Monitor • MS DOS • GW BASIC

\$1549

- Same w/ 20 MB Hard Drive.....\$1799
- Same w/ 30 MB Hard Drive.....\$1849
- Same w/ 40 MB Hard Drive.....\$1949

NEC POWERMATE 386
IBM AT COMPATIBLE 40 MB
HARD DRIVE PACKAGE

- Keyboard • 80386 Process. • 1 MB RAM • 1.2 MB Floppy Drive • 40 MB Hard Drive • Serial & Parallel Ports • 12" Monitor • MS DOS • GW BASIC

\$3499

COMPAQ 286 MODEL 1
IBM AT COMPATIBLE PACKAGE

- 640K • 1.2 MB Floppy Drive • 7 Expansion Slots • 8-12 MHz • 12" Monitor • MS DOS & GW Basic

\$1799

- COMPAQ C-286 MODEL 20MB PKG.....\$2299
- COMPAQ C-286 MODEL 40MB PKG.....\$2699

commodore PC10-1

IBM XT COMPATIBLE PKG.

- 512K RAM • 360K Floppy Drive • 12" Monitor • Serial & Parallel Ports • Keyboard • Box of 10 Diskettes • MS/DOS

\$499

We Can Reconfigure Any Of Our Computer Packages To Your Specifications. Call For Information. We Carry Modems, Drives, Cards, Color Monitors & All Other Accessories For Your Computer.



SANYO PR-3000A

Daisy Wheel Letter Quality

\$59.95

We Can Reconfigure Any Of Our Computer Packages To Your Specifications. Call For Information. We Carry Modems, Drives, Cards, Color Monitors & All Other Accessories For Your Computer.

SEAGATE 20, 30, 40, 60, 80,
MB HARD DRIVES
IN STOCK!

LEADING EDGE

MODEL D2
IBM AT COMPATIBLE 20 MB
HARD DRIVE PACKAGE

- Keyboard • 640K • 1.2 MB Floppy Drive • 20 MB Hard Drive • 12" Monitor • MS DOS • GW BASIC/Word Processor

\$1449

- SAME w/ 30 MB HARD DRIVE.....\$1499
- SAME w/ 40 MB HARD DRIVE.....\$1599
- SAME w/ 65 MB HARD DRIVE.....\$1869

LEADING EDGE

MODEL D
IBM XT COMPATIBLE PKG.

- 512 K RAM Computer • Keyboard • 360K Floppy Drive • 4.77-7.16 MHz • 12" Monitor • 8088.2 Processor • MS DOS/ GW Basic

\$699

- SAME w/TWO 360K FLOPPIES.....\$759
- SAME w/ 20 MB HARD DRIVE.....\$949
- SAME w/ 30 MB HARD DRIVE.....\$999

AMSTRAD PC1640

- Keyboard • 640K RAM Turbospeed • Two 360K Drives • 12" Monitor • FREE Mouse and Software • MS DOS • GW Basic

\$729

W/ONE FLOPPY & 20MB. \$1029

commodore COLT

IBM XT COMPATIBLE PACKAGE

- Keyboard • Two 360K Floppy Drives • Serial & Parallel Ports • 12" Monitor • MS DOS/GW Basic

\$699

Apple PACKAGES

- APPLE IIC w/ Floppy Drive & 12" Monitor \$599
- APPLE IIE w/ 5.25 DISK DRIVE & 12" MONITOR.....\$749

APPLE IIGS COMPUTER PKG.

- Apple IIGS Computer • 512K Upgrade • RGB Color Monitor • 3.5" Disk Drive

\$1399

- IMAGEWRITER II Printer.....\$449
- MAC SE Computer w/ Dual Drive.....\$2299
- MAC SE Computer w/20MB APPLE Hard Drive.....\$2749
- APPLE MAC II.....\$3498
- APPLE MAC II w/40MB.....\$4299

AMIGA 2000

IBM XT COMPAT. RGB COLOR PKG

- A-2000 Computer w/Keyboard • 1 MB Expandable to 9 MB • Built-in 3.5" Disk Drive • RGB Color Monitor • 2088 IBM Compatible Bridge Card w/ 5.25" Floppy Disk Drive

\$2099

FREE MOUSE AND SOFTWARE

AMIGA 500

RGB COLOR PACKAGE

- Amiga 500 w/512 K • Built-in 3.5" Disk Drive • Mouse • RGB Color Monitor • All Power Supplies and Cables • FREE Software

\$759

RGB COLOR SYSTEM
Amiga 500 with 1084S
RGB Color Monitor

\$829

Amiga 500 Computer w/1084S
Mon. & 1010 3.5" Floppy Drive

\$1029

ALL AMIGA COMPUTERS & PERIPHERALS IN STOCK!

commodore 128D PACKAGE

- Commodore 128D Computer w/Built-in Disk Drive
- Commodore 1902 Color RGB Monitor
- Commodore Color Printer
- 64c PACKAGE

\$699

Commodore 64c Computer Commodore 1541C
Disk Drive Commodore Color
Printer 12" Computer Monitor

\$389

MONITORS THOMSON 14"CGA Monitor.....\$289

- MAGNAVOX 13" RGB Color Monitor.....\$199
- MAGNAVOX EGA Monitor.....\$339
- w/ EGA Card.....\$459
- MAGNAVOX VGA Monitor.....\$369
- w/ VGA Card.....\$569

NEC MULTISYNC II.....\$579

IBM XT Hard Drive Package

IBM XT Computer • IBM Keyboard 256K RAM
Expandable to 640K • 360K Disk Drive • 20 MB
Hard Drive • Package of 10 Diskettes
(Monitor Optional)

\$1199

IBM XT Package with
Two 360K Floppy Drives

\$999

AST PREMIUM 140X PKG.

- 80286 Processor
- 1 MB Fast-RAM
- 1.2MB Floppy Drive
- 12" Monitor
- MS DOS
- GW Basic

\$2249

- With 20 MB.....\$2499
- With 30 MB.....\$2549
- With 40 MB.....\$2649

BLUE CHIP
1/2 HL 360K 5 1/4" Internal
Floppy Disk Drive

\$49.95

IBM PERSONAL SYSTEM 2

- PS//Model 30.....\$1299
- PS//Model 30 w/ 20 MB.....\$1699
- PS//Model 30/286-002.....\$1549
- PS//Model 30/286-021.....\$1899
- PS//Model 50 w/20MB.....\$2489
- PS//Model 50Z w/30MB.....\$2849
- PS//Model 50-061.....\$3249
- PS//Model 60-041.....\$3200
- PS//Model 60-071.....\$3619
- PS//Model 70-E61.....\$4199
- PS//Model 80-041.....\$4286
- PS//Model 80-071.....\$4799
- AMTECH 5.25" 360K External Drive for
IBM PS//30.....\$169
- PACIFIC RIM 5.25" 1.2 MB External Drive
for IBM PS// 50/60/70/80.....\$259
- IBM PERSONAL SYSTEM II MONITORS
- 8503 Monochrome.....\$339
- 8513 Color.....\$339

PRINTERS

- | STAR | EPSON |
|-------------------------------------------------|--------------------------------------------|
| NX-1000.....\$219.95 | FX-1050.....\$489.95 |
| RAINBOW.....\$189.95 | FX-850.....\$339.95 |
| NX-1000.....\$189.95 | FX-500.....\$215.95 |
| NX-2400.....\$304.95 | LQ-500.....\$529.95 |
| | LQ-950.....\$589.95 |
| | LQ-1050.....\$729.95 |
| | LQ-2550.....\$959.95 |
| | LX-950.....\$1199.95 |
| 321-SL.....\$449.95 | |
| | PANASONIC SPECIAL EXP-450 LASER.....\$1400 |
| | OKI-120.....\$189.95 |
| | OKI-1020.....\$119.95 |
| | OKI-160.....\$239.95 |
| | 1080-II.....\$159.95 |
| | 1092L.....\$299.95 |
| | 1091-III.....\$189.95 |
| | KXP-1524.....\$499.95 |
| | KXP-1595.....\$409.95 |
| | KXP-1124.....\$319 |
| Diconix 150 Printer For
Laptops.....\$299.95 | |

1 MB Expander \$349 HP DESKJET PRINTER \$689



dBASE IV Arrives

A major revision brings better performance and more features—in a bigger package

Malcolm Rubel

After months of speculation about the newest version of Ashton-Tate's flagship product, dBASE IV version 1.0 is finally here. Is the finished product worth the wait? I think so. While the program is lacking in a few areas, such as its implementation of user-defined functions (UDFs) and true Structured Query Language (SQL) support, it represents a quantum leap over dBASE III Plus in functionality, power, and ease of use.

A lot of the prepublication criticism surrounding dBASE IV was based on the assumption that Ashton-Tate was trying to include the unique capabilities of every competing database package and more. Users worried that this approach would make the product so large as to be unusable. Fortunately, this turned out not to be the case. While the program is large, it's not unwieldy to use.

In a nutshell, Ashton-Tate has significantly increased both dBASE's features and the scope of the dBASE language. And while dBASE IV isn't uniformly faster than dBASE III Plus, performance has been greatly improved. The new (standard) version sells for \$795 and runs on any IBM PC or compatible with 640K bytes of memory and a hard disk drive.

It takes time to digest dBASE IV. The program comes on 14 disks with 1570 pages of documentation in 10 manuals.



The program is, however, easy to install: You simply invoke the INSTALL.BAT file and follow the directions. dBASE IV isn't copy-protected, but you do "brand" your copy of the program with your name. Unlike previous versions, dBASE IV lets you select up to four printers, specify 43-line mode (EGA), and change your CONFIG.SYS and AUTOEXEC.BAT files and other custom options. Once you've installed the program, the manuals, on-line help, and tutorial provide ample assistance to get you up and running.

The best way to examine dBASE IV is by breaking it down into its three major functional components: the database engine, the language, and the Control Center.

The Engine

If you're a dBASE III Plus user, the first difference you'll notice in dBASE IV is its size. While dBASE III Plus ran on a 256K-byte system with two floppy disk

drives, dBASE IV needs at least 640K bytes and a hard disk drive. Ashton-Tate has decided to go for performance, and if you want it, you'll have to equip your machine to handle it.

The number of fields per record has increased from 128 to 255, and the maximum number of keys (indexes) per table has gone from 7 to 47. Using DOS 3.1 or higher, dBASE IV supports up to 99 open files at once, although it still supports only 10 data tables. Field length and the maximum size of the command line have both been raised from 254 to 1024 characters. There's a command-line editor to make typing long lines easier. And Ashton-Tate has increased the maximum number of memory variables from 256 to 15,000, freeing programmers from one of the most irksome constraints in dBASE III Plus.

Indexing is another major improvement. With dBASE III Plus, you could have up to seven indexes (each using a

continued

Table 1: Comparative execution speed benchmarks for dBASE III Plus and dBASE IV. All tests were performed on an IBM PC AT running at 6 MHz with a Priam 28-millisecond-access-time hard disk drive and 567K bytes of memory. The drive was cleaned using Norton Speed Disk before each test. (All times in seconds.)

Test	dBASE III Plus	dBASE IV
Screen 1	55	12
Screen 2	93	21
Screen 3	192	33
Append	37	25
Calc 1	188	25
Calc 2	60	5
Calc 3	145	8
Calc 4	32	23
Calc 5	975	73
Locate 1	39	42
Locate 2	25	46
Replace	76	48
Sort 1	86	79
Sort 2	46	42
Sort 3	108	101
Sort 4	84	80
Index 1	123	70
Index 2	77	43
Index 3	174	86
Index 4	52	45
Index 5	110	102
Join	516	763
Seek 1	53	22
Seek 2	62	25
Seek 3	58	28
Seek 4	44	21
Linked seek	48	48

file handle) open for a single data table. dBASE IV lets you have up to 47 index files open inside a master index file (.MDX) that takes up only a single file handle. Open indexes are no longer a constraint on system design.

The dBASE IV engine now supports two numeric data types: binary coded decimal (BCD) and floating point, which use the dBASE data types N and F, respectively.

Memo fields used to give programmers headaches. Now you can store up to 64K (previously 4K) bytes of data in a memo field, which means that you can actually use them to do work. You can use string functions and the GET command on memo fields and define a win-

dow for editing them instead of having the memo field automatically take over the entire screen. Garbage collection, once a problem, is now automatic.

dBASE III Plus allowed for only a single active parent-child relationship. dBASE IV lets you relate multiple children to a single parent using different keys. In many instances this allows a substantial reduction in code size and complexity.

Finally, execution speed is significantly higher because dBASE IV preparses code to save execution time (see the comparative benchmarks in table 1). A "compiler" translates dBASE programs into intermediate code, checking for syntax errors while assembling code tokens for execution. This is not a *true* compiler, however. The dBASE IV compiled code comes out in .DBO files (not .EXE files) and still needs either dBASE IV or dBASE Run Time to execute.

You may find that your dBASE III Plus code generates compiler errors when first run under dBASE IV. As an interpreter, dBASE III Plus simply executes the first line of code that meets the specified condition of an IF...ELSE...ENDIF or a DO CASE structure. If there's no ENDF or ENDCASE statement, it doesn't matter, because the interpreter never reaches that line. This makes a difference with dBASE IV, however, so you'll find out all about your bad coding practices.

As expected, the performance benchmarks for dBASE IV show the greatest speed improvements when no disk access is required (see table 1). Surprisingly, several of the direct data table functions (locate and join) were slower when executed by dBASE IV than they were when executed under dBASE III Plus. Fortunately, most users will seldom need these features.

While I ran the benchmarks in the table in 567K bytes of available memory, I also tried to run them in the least amount of memory possible. I managed to get the entire set of benchmarks to run in 477K bytes of memory, and the only major speed penalty appeared in indexing test files (seeking was not affected). Index speeds were about a third slower.

The Language

dBASE IV has enhanced and added features to the dBASE language while retaining compatibility with dBASE III Plus. Some commands, however, are different from those used in competing products such as FoxBASE and Clipper. The new menu commands in dBASE IV are a prime example. But the changes

have definitely improved the language, and the capability to add true context-sensitive help to applications you're developing is a vast improvement over dBASE III Plus.

Ashton-Tate swears by its statement of 100 percent upward compatibility, and, indeed, everything I ran with dBASE IV worked—even old report and label files. The first time you execute your old dBASE III Plus report forms, the program converts the binary file into dBASE code and then compiles and executes it.

The additions and differences between dBASE IV's 310 commands and functions and those in dBASE III Plus are so extensive that I can't cover all of them in a single article. But some of the more interesting command sets include the following:

- A complete set of commands for defining, saving, and using regular pull-down menus and Lotus-type menus.
- A true BROWSE command that's under the programmer's control.
- A full set of commands for defining, using, and saving windows.
- Two-dimensional array commands (arrays can include up to 1170 elements).
- An enhanced GET command that includes the VALID clause and conditional editing (WHEN), with custom prompts and error messages for each GET.
- Twenty-eight new SET commands.
- New direct date handling using the format {mm/dd/yy}.

dBASE IV supports UDFs, which let programmers plug in custom-designed routines. This enhancement alone might have made dBASE IV worth the price. Unfortunately, there are several major limitations to dBASE IV's implementation of UDFs.

First, you must declare functions either in the current procedure file or at a higher level in the program. The easiest way to do this is to include *all your functions* in the declared procedure file (SET PROCEDURE TO) so that they're available globally.

Second, you can only use the CLEAR and READ commands *conditionally*. CLEAR can have no arguments, and you can use READ only if no format file is active. Both of these restrictions are annoying, but what's more limiting is that you can't use the 81 commands and 13 SET commands in a UDF. Also, you can't do macro expansion in a user-de-

continued

We Just Made Choosing Your Graphics Card



As Easy As 1,2,4.

You've probably seen our TrueVista products, or you've heard about their powerful features like the real-time frame capture, on-board TI 34010 coprocessor, large frame buffer, NTSC/PAL compatibility and more. Recently, we announced several new products in the series, each with unique potential for your

applications from video to digital pre-press to image processing. So now, whether your choice is an AT-class platform or the Macintosh® II, you only need one source for your graphics needs, the TrueVista series. The chart below outlines several key differences in the 5 products.

TrueVista Series

FEATURES	ATVista 1M	ATVista 2M	ATVista 4M	NuVista 2M	NuVista 4M	
BUS	AT	AT	AT	NuBus	NuBus	
MAXIMUM ADDRESSABLE RESOLUTIONS	32 bits/pixel 16 bits/pixel 8 bits/pixel	512 x 512 1024 x 512 1024 x 1024	1024 x 512 1024 x 1024 2048 x 1024	1024 x 1024 2048 x 1024 2048 x 2048	1024 x 512 1024 x 1024 2048 x 1024	1024 x 1024 2048 x 1024 2048 x 2048
VMX EXPANSION	2-10 Mbytes	2-10 Mbytes	2-10 Mbytes	TBA	TBA	
PRICE	\$2995.	\$4250.	\$5995.	\$4250.	\$5995.	

Now There's Software You Can Count On, Too.

To complete the equation, add in STAGE™, our comprehensive graphics environment for the 34010. Since STAGE is host-independent, it allows you to access the coprocessor directly, regardless of the bus. So your program on the AT can be quickly ported to the Macintosh II. Customers will not be tied to one platform either, as files and programs will be compatible across both hosts. STAGE is currently available for the AT Vista series, and will be available soon for the NuVista as well.

With the new members of the TrueVista family and the release of STAGE, you now have everything you need to develop exciting new products for the next generation of computer graphics. And many applications are already appearing to assist you in your immediate needs. Contact us to learn more about our products or our third-party developer program and the support available to you. You'll soon see how you can count on Truevision to provide all your graphics solutions.



TRUEVISION® INC.

7351 Shadeland Station, Suite 100, Indianapolis, IN 46256 800/858-TRUE

INTERNATIONAL: Canada 416/499-9400 France 33-13-952-6253 Italy 39-2-242-4551 Switzerland 41-1-825-0949
U.K. 44-1-991-0121 West Germany 49-89-612-0010 Other 617/229-6900

Prices quoted are US Domestic suggested retail prices. Macintosh is a registered trademark of Apple Computer, Inc.

Circle 237 on Reader Service Card

dBASE IV version 1.0

Type

Database manager

Company

Ashton-Tate, Inc.
20101 Hamilton Ave.
Torrance, CA 90502
(213) 329-8000

Format

Standard Edition: 14 5¼-inch floppy disks
Developer's Edition: 17 5¼-inch floppy disks

Hardware Needed

IBM PC or compatible with 640K bytes of memory and a hard disk drive

Software Needed

DOS 2.1 or higher; DOS 3.1 or higher needed for extended file support

Language

C

Documentation

Standard Edition: 38-page Change Summary, 20-page Getting Started, 85-page Learning dBASE IV, 240-page Using the Menu System, 134-page Using the Applications Generator, 46-page Introduction to the Dot Prompt, 198-page Advanced Topics, 70-page Network Installation, 676-page Language Reference, 63-page Quick Reference

Price

Standard Edition: \$795
Developer's Edition: \$1295

Inquiry 1065.

defined function. This is crippling and will force programmers to write many good functions as procedures.

Finally, Ashton-Tate UDFs rigorously enforce parameter passing. If you declare a parameter, you must pass it. By contrast, Nantucket Corp.'s Clipper lets you pass fewer than the declared number of parameters. Using its PCOUNT() (parameter count) function, you can then substitute default values for the unnamed parameters. I had hoped Ashton-Tate would add this capability in dBASE IV.

In contrast to dBASE III Plus, dBASE IV has a debugger that's workable. The compiler also gives the programmer more information about syntax errors than did its predecessor. For me, it's actually a pleasure to debug programs in dBASE IV.

dBASE IV also treats programs and procedures differently. It treats all programs as procedures and allows multiple procedures in a single .PRG file. You're no longer restricted to procedures only in the named procedure file. Any program file can now contain 963 procedures or functions (up from 32), and you can have up to 32 open procedure files at one time. You can also write proper modular code and have virtually all your programs included in one or two procedure files. The concern for the number of open files that was always hanging over the dBASE III Plus programmer's head is gone.

Last, dBASE IV includes a program editor that will be familiar to Framework users. Program length is now 32,000 lines, as opposed to the previous 4000-byte limit. The manual states that you can replace the program editor with your own, but the editor I use, XyWrite, wouldn't fit into the memory remaining after loading dBASE.

The dBASE IV editor's one serious drawback is that it's slow when working with large files. It took 37 seconds to load and 17 seconds to save a 2100-line program file on my AT's hard disk drive. The debug cycle also can suffer from this type of limitation.

The Control Center

What's extraordinary about dBASE IV is that much of its power is also available to the nonprogrammer through its task-oriented, nonprocedural Control Center. The Control Center is to dBASE IV what the Assist mode is to dBASE III Plus. But while Assist was inadequate, the Control Center is a powerful dBASE shell with a point-and-shoot interface that lets you develop customized applications without writing code.

The Control Center is a collection of well-thought-out work surfaces that let you define data tables, screens, reports, and labels and tie them together through the application generator. The work surfaces are intuitive in nature, and with just a little experience, you should be able to design functional programs.

The report writer is a vast improvement. It looks like Concentric Data Systems' R&R Relational Report Writer for dBASE. You can now create a wide variety of customized layouts. And since dBASE IV now fully supports a variety of printers, you don't have to write routines when you want to print in anything other than normal text. The program supports many standard types of labels in its label panel. dBASE IV also gives you the opportunity to define your own label specification.

The forms designer looks a lot like WallSoft Systems' UI Programmer software, but it isn't as easy or as powerful to use. The screen painter shows only 19 lines on the screen. Although you can scroll up to create a full screen (or even multipage screens), it would be better if you could see the complete screen in development. You can add pictures, ranges, valid statements, error messages, and editing conditions to suit your needs.

You can also define queries in a query-by-example panel that either uses a single table or links two or more tables together. Queries can be conditional, and you can present them either in table form or in a user-defined screen form (.FMT). You can create queries without writing a single line of code, and once set, you can carry them over to the reports and labels sections. While it would be an overstatement to say that a first-time user could do it with ease, new users can learn to develop sophisticated queries.

Finally, you can now record keyboard macros for later playback, automating repetitive tasks.

The most remarkable thing about these tools is that, unlike dBASE III Plus, which wrote binary files for report and label specifications, dBASE IV writes out program code. Sophisticated users can then modify this code to suit personal needs, and those who have the Developer's Edition of dBASE IV can also write customized templates.

A Step Toward SQL

Structured Query Language is currently a hot topic, and dBASE IV supports SQL—sort of. Actually, it emulates SQL using dBASE data tables. You can use a set of SQL commands inside dBASE by typing SET SQL ON. This deactivates the dBASE IV commands that conflict with the SQL language.

Essentially, a series of translation tables lets you use SQL commands to work on dBASE tables. But it's not SQL. And it's slow because of the intermediate steps that the program must take to execute the code. I recommend that you wait until the Ashton-Tate/Microsoft Database Server comes out before using the emulation.

While users still must wait for true SQL support, Ashton-Tate has done much to satisfy the needs of the multi-user system developer. dBASE IV is transparently multiuser. File and record locking are better thought out, and the BEGIN TRANSACTION/ROLLBACK command set is a godsend that will keep developers from having to create small

continued

We Guarantee Good News Every Monday Morning!



In fact, we'll guarantee the best news—100% factual, accurate and unbiased expert analysis of significant developments in the personal computer industry. Just straightforward, no-nonsense professional reporting of industry news, product announcements and key events *as they happen* each and every week.

BYTEweek, McGraw-Hill's new weekly newsletter, is devoted to helping you stay on top of the dramatic changes in the continually-evolving business computing arena. BYTEweek is devoted to reporting and analyzing these changes and developments through its timely, compact, one-stop news format. BYTEweek keeps you on top of significant industry trends and developments through its coverage of the IBM, IBM-compatible, Apple Macintosh and workstation markets. BYTEweek gives you the full details of significant new product announcements with in-depth analysis.

BYTEweek guarantees what no other personal computing publication can by building on two renowned and respected technical resources: the award-winning *Microbytes Daily* on-line news service and the technical expertise of the BYTE Editorial Staff aided by the new resources available to them in the recently expanded BYTE Lab. Through these resources, you are kept on top of issues such as:

- **New data storage techniques**, including CD-ROM, erasable optical and other text, graphics, and video storage technology.
- **Expert systems**, with an examination of both the technical and human aspects of implementation.
- **Bus standards** and the war between IBM and the clone manufacturers—with critically important user ramifications.
- **Legal skirmishes** and "look and feel" suits, which can put the manufacturer of your favorite software out of business.
- **Software emulation** that will allow new, exotic computer systems to run software written for IBM PCs.
- **LAN system developments**, including all pertinent aspects of connectivity and inter-operability.
- **Network management**, a complex and increasingly important topic for personal computers in both small and large offices.
- **PostScript clones**, which promise faster, lower-cost laser printers with the same capabilities as the Apple LaserWriter.
- **New, easy-to-use programming systems** such as CASE and 4th Generation Languages, that can allow non-programmers to develop powerful applications.

BYTEweek offers you what no other industry publication can: timely news on the rapidly evolving computer industry *as it happens*, framed by interpretation and evaluation that only BYTE's experienced editorial staff can provide.

Subscribe now and take advantage of the special one-year charter subscription rate of **\$395** (\$495 outside the U.S. and Canada)—a *savings of \$100 off* the regular rate. Your subscription to BYTEweek includes 50 issues and a free subscription to BIX, which includes access to the award-winning *Microbytes Daily* on-line news service. Your hourly usage rates will be billed separately.

Don't miss this opportunity! Call BYTEweek's toll-free number:

1-800-258-5485

to order your subscription or request more information and a free sample issue.

BYTEWEEK

One Phoenix Mill Lane, Peterborough, NH 03458

1-800-258-5485

Charter subscription just \$395 for 50 weekly issues



Computers For The Blind

Talking computers give blind and visually impaired people access to electronic information. The question is how and how much?

The answers can be found in "The Second Beginner's Guide to Personal Computers for the Blind and Visually Impaired" published by the National Braille Press. This comprehensive book contains a Buyer's Guide to talking microcomputers and large print display processors. More importantly it includes reviews, written by blind users, of software that works with speech.

This invaluable resource book offers details on training programs in computer applications for the blind, and other useful information on how to buy and use special equipment.

Send orders to:
National Braille Press Inc.
88 St. Stephen Street
Boston, MA 02115
(617) 266-6160

\$12.95 for braille or cassette, \$14.95 for print. (\$3 extra for UPS shipping)
NBP is a nonprofit braille printing and publishing house.

data tables for each transaction and then appending them when a transaction is finished. Automatic and immediate screen refresh is another excellent feature, as are the program's eight security levels. Another good addition is support for shared locks, which let other users view data while you're editing it.

For the serious dBASE programmer, Ashton-Tate also offers a \$1295 Developer's Edition. At \$500 more than the Standard Edition, it's a bargain. The package contains everything in the stan-

I f you don't have a hard disk drive and 640K-byte memory, you might as well forget dBASE IV.

dard product, plus a linker that lets you bind all procedure and program files into a single file and do overlays for memory management. It also includes an unlimited run-time license so that you can distribute applications (single or multi-user) royalty-free.

The Developer's Edition also comes with two LAN keys so that you can set up and use a three-station LAN with one copy of the program. Also included is a template language and compiler. You can develop or modify programs to suit your needs, compile them, and use them from the Control Center to produce customized programs. Finally, Ashton-Tate says it will ship its .EXE compiler to registered Developer's Edition users when it's available.

dBASE's Downside

Because dBASE IV is so powerful, you pay a price in terms of the system resources it requires. Ashton-Tate makes no apologies about the size of dBASE IV. But if your machine doesn't have a hard disk drive and at least 640K bytes of memory, you might as well forget about dBASE IV. And if you absolutely have to have terminate-and-stay-resident (TSR) programs running, you'll need a copy of DESQview or Windows (I use DESQview so that I can use my own editor in a window to write and debug programs). dBASE IV will run on a LAN, but net-

work overhead will be cutting your margins thin in terms of memory.

The size of dBASE IV will also influence your programming style. Ashton-Tate decided to define and save windows and menus in memory so they will pop up quickly. But when you have seven or eight menus defined, five or six large windows, 600 memory variables, and a couple of arrays defined, you don't have much memory left. You can save windows (but not menus) to disk to save memory, but this option requires time-consuming disk I/O to reactivate the windows.

You can now include up to 963 procedures in a procedure file, and you can call down through 32 nested procedure files. But 963 is the theoretical maximum. Each procedure requires a procedure name and a pointer stored in memory and takes 25 bytes of memory. The maximum number of procedures depends on how much memory is available. The actual limits placed on the product mean that for most users' systems, the limits are much lower than the theoretical maximums.

Worth the Wait

Is dBASE IV worth the price? The answer is a qualified yes. If you've got the system resources, dBASE IV is an excellent choice, whether you're a dBASE III Plus user or a newcomer considering buying dBASE for the first time. Many developers, however, probably will wait for the release of version 1.1 to see whether bugs and shortcomings, such as dBASE IV's limitations on UDFs, are cleared up before porting all their applications to dBASE IV.

It is likely that undiscovered bugs will come out when 50,000 people start using the product. Only 2 weeks before dBASE IV was introduced, a beta user reported that he could not compile a program file with 1000 procedures in it. Ashton-Tate then lowered the number of procedures from 1170 to 963. [Editor's note: *Due to the complexity of dBASE IV and unconfirmed reports of other bugs, BYTE is doing further testing on it. Look for a Review Update on dBASE IV in an upcoming BYTE.*] But the product seems solid overall, and most users will find that dBASE IV was well worth the wait. ■

Malcolm Rubel, president of Performance Dynamics Associates, a business applications consulting firm in New York City, is currently at work on his new book, dBASE IV Procedures and Functions. He can be reached on BIX c/o "editors."

Knowledge, Experience & Expertise

your most valuable resources.



Now available on the IBM PC!

KnowledgePro® is a tool for "explaining things" using a computer. It combines HYPERTEXT and EXPERT SYSTEM technologies in a high-level language to let you write stand-alone applications or add an intelligent, aesthetic interface to your existing programs.

KnowledgePro stores knowledge in natural "chunks" called topics. It lets non-programmers communicate complex information using simple commands like SAY, ASK, IF, DO and PICTURE.

KnowledgePro lets you integrate hypertext, rules, math, lists, and logic quickly and easily. With our Database Toolkit you can read Lotus 123 and dBASE III files. The Graphics Toolkit lets you define hypergraphics using PC Paintbrush images. The VideoDisk Toolkit provides complete control of interactive laser video.

KnowledgePro reads, writes and searches text files. You can include routines written in other languages and call other programs.

Your **KnowledgePro** application can ask users for information you need to bring together resources and explanations they need. You can retrieve text, graphics, data, and video information, perform calculations, create text files and run programs based on each user's unique problems, interests and level of expertise. "I recommend that you check out **KnowledgePro**", said Steve Ciarcia of BYTE. "So much fun to work with", said Mickey Williamson in PCWEEK. "I LOVE **KnowledgePro**. It's less like programming and more like writing", said Dan Shafer of PC AI.

KnowledgePro runs on IBM PC XT, AT and PS/2 compatibles with 640k. It costs \$495 plus \$8 shipping (\$58 foreign). There are no run-time charges, so you don't have to pay more to distribute applications. The Database, Graphics and VideoDisk Toolkits cost \$49, \$89 and \$249 respectively. **KnowledgeMaker** our induction system for creating rules from data costs \$99. **Stock Expert**, a system for the personal investor, costs \$249. A working demonstration system, with a 100 page manual, is available for \$30 plus \$5 shipping (\$8 foreign) with credit toward purchase of the full system.

Circle 122 on Reader Service Card

For product literature, review reprints or to order:

Call 518-766-3000

(FAX 518-766-3003)

Amex, M/C, Visa, COD or send check to:
Knowledge Garden Inc., 473A Malden Bridge Rd.
Nassau, NY 12123, USA.

New York residents please add 7% sales tax.

KnowledgePro®
A tool for communicating knowledge

by Bev & Bill Thompson

Join us on CompuServe (GO PCVEN user option #8)

from



KnowledgePro is a trademark of Knowledge Garden. IBM, dBASE III, Lotus 123, CompuServe and PC Paintbrush are trademarks of their respective corporations. Photo Tcherevkoff ©

NOW THERE ARE TO THE POST

PostScript printers and typesetters offer a variety of resolutions, paper handling options and printer speeds, as well as black & white and color output.



In just three years, the PostScript language has been adopted by more than 25 of the world's leading computer equipment manufacturers.

Agfa-Gevaert Apollo Computer
Apple Computer AST Research
Autologic Dataproducts Diconix
Digital Equipment Corporation Fujitsu
General Computer Hewlett-Packard IBM
Linotype Matsushita Monotype NBI
NEC NeXT QMS Quadram
Qume Ricoh R.R. Donnelley
Scitex Texas Instruments
Varityper Wang



More than 3,000 software programs—for minicomputers, mainframes, workstations and personal computers—support the PostScript language.

THE OUTSIDE.

To professionally print words and pictures on the same page, all you need are laser printers and typesetters that speak the right language. The language of PostScript.

As the standard page description language of electronic publishing,

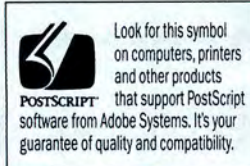

Look for this symbol on computers, printers and other products that support PostScript software from Adobe Systems. It's your guarantee of quality and compatibility.

PostScript software from Adobe Systems is your key to complete device independence—giving you the freedom to select the right hardware, software and vendors for your needs and budget.

Isn't it time you put the power of PostScript on your side?

Adobe and PostScript are registered trademarks and the Adobe logo, the PostScript logo, and Display PostScript are trademarks of Adobe Systems Incorporated. The logos of the original equipment manufacturers supporting PostScript and the Display PostScript system and the software titles supporting PostScript are the trademarks or registered trademarks of their respective companies. © 1988 Adobe Systems Incorporated. All rights reserved.

RE TWO SIDES SCRIPT® STORY.

digital



IBM

Display PostScript is already the graphics standard for a new generation of computer and workstation displays from these manufacturers.



Computers and workstations with the Display PostScript system deliver a variety of screen resolutions in black & white, grayscale and color.



Taking advantage of enhanced software portability, applications with greater power and potential are already emerging to support Display PostScript.

THE IN SIDE. Introducing Display PostScript™ from Adobe. With the same imaging standard and language used in PostScript printers, this system software module is now in computer and workstation displays.

And because it's transparently integrated over a variety of operating systems, Display PostScript is your key to hardware compatibility and software portability.

Take advantage of a powerful, new graphics standard for today—and tomorrow. Be sure to insist on the Display PostScript system.

If you'd like more inside information about PostScript software and/or the Display PostScript system, call 800-29-ADOBE.

ADOBE™
SYSTEMS INCORPORATED



Personal Workstations

- 229 **Two Worlds Converge**
by Nick Baran
- 235 **The Current Crop**
by Bill Nicholls
- 245 **Worth the RISC**
by Trevor Marshall and Jane Morrill Tazelaar
- 251 **How Fast Is Fast?**
by Bill Kindel
- 255 **Art + 2 Years = Science**
by Phillip Robinson
- 267 **Networking with Unix**
by Greg Comeau
- 270 **The Players**

As personal computers have grown in size and capability, they've begun to encroach upon the workstation arena. And as workstations have added features that make them more accessible and user-friendly, they've begun to reach into the personal-computer arena.

As a result, we now have a new breed of computer with the capabilities of a workstation and the accessibility of a personal computer—the personal workstation. This new breed includes high-end personal computers and low-end workstations that share certain minimum requirements and cost less than \$20,000. In "Two Worlds Converge," Nick Baran discusses these requirements and the merger taking place between what were once two separate and distinct fields.

Then, Bill Nicholls looks at "The Current Crop" of workstations, including the latest offerings from Apollo Computer, Sun Microsystems, Silicon Graphics, and NeXT. He also discusses his own experiences trying to convert his 80386-based machine into a workstation. In their quest for speed, workstations will undoubtedly explore reduced-instruction-set-computer architecture. In "Worth the RISC," Trevor Marshall and I discuss RISC technology and compare the various RISC chips available today.

The speed question seems to come up in the computer field whether you're talking about chips or peripherals or just about anything else, and it comes up here

as well. But what do all those various ratings mean? MIPS? MHz? MFLOPS? In "How Fast Is Fast?" Bill Kindel sorts out the various speed measurements and tells us what they do—and don't—imply.

You can't talk about workstations without discussing graphics, and in "Art + 2 Years = Science," Phillip Robinson delves into the state of the art in workstation graphics, from techniques to applications to machines. You also can't talk about workstations without discussing Unix and networking. In "Networking with Unix," Greg Comeau combines the two and compares Sun's Network File System with AT&T's Remote File System.

Personal computers and workstations once seemed to be two separate and distinct fields. Their capabilities were different, their uses were different, and their prices were very different. Today, the edges of those fields overlap, and the personal workstation is born. And tomorrow? If current trends are any indication, tomorrow will bring a continuum of microprocessor speed and performance from which we can only benefit.

—Jane Morrill Tazelaar
Senior Technical Editor, In Depth





Pack extra power into your PC.

Make it over into a '386.

DTK's new PEM-2000 dual-speed 8/20 MHz 80386 motherboard gives you 100% PC/AT compatibility at speeds up to 27.3 MHz. It also offers some very elegant engineering, like eight expansion slots including two for 32-bit memory expansion, two serial ports and one parallel port, a DTK BIOS with built-in diagnostics, and the socket for an optional 80387 coprocessor.

DTK means value in PC-compatible motherboards, add-on and networking cards, and bare bone systems, including FCC Class B-certified 10 and 12 MHz '286 computers. Which is why the two high-speed XT clones named "Best Buys" in *PC World's* August, 1988 issue, both use DTK motherboards.

The PEM-2000 is a good example—but by no means the only example—of the DTK difference. To get the full story on all our high-performance XT, '286 and '386-based products, contact the DTK office nearest you for specifications and pricing.

And find out how to pack some extra power into your PC.

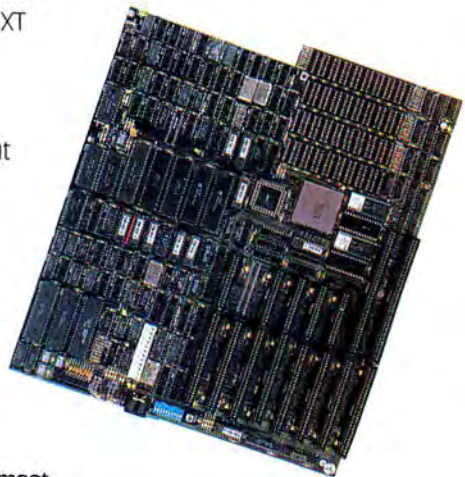

® Where price and performance meet.

DTK COMPUTER INC.

15711 E. Valley Blvd. • City of Industry, CA 91744
Tel: (818) 333-7533 • Fax: (818) 333-5429

DTK Computer Inc. of Florida
7245 Corporate Center Dr, Suite B
Miami, FL 33126
Tel: (305) 477-7440
Fax: (305) 477-8322

DTK Computer Inc. of New Jersey
300 Columbus Circle, Raritan Center
Edison, NJ 08818
Tel: (201) 417-0300
Fax: (201) 417-0307

DTK Computer Inc. of Texas
10535 Wilcrest Dr, Suite 120
Houston, TX 77099
Tel: (713) 568-6688
Fax: (713) 568-5688

EXCLUSIVE DISTRIBUTORS:
Florida: TWC (305) 599-0871
Northern California: Supercom
(415) 770-1100
San Diego, Nimax
(619) 566-4800

DTK Computer GmbH
Wahlerstr. 16
4000 Dusseldorf 30
West Germany
Tel: (0211) 656031
Fax: (0211) 653753

AT and XT are registered trademarks of International Business Machines Corporation. DTK is a registered trademark of Datatech Enterprises Co., Ltd.

Two Worlds Converge

As workstations become more friendly and PCs grow in capability and capacity, the personal workstation is born

Nick Baran

Perhaps the one constant in the computer industry is that the price/performance ratio keeps going down. Each year, you get greater performance and capabilities for your money.

Consider that, in 1982, an 8088-based IBM PC with 64K bytes of memory, two floppy disk drives, and a monochrome display cost close to \$5000. Today, you can buy an 80386 machine with 2 megabytes of memory, a hard disk drive, and a high-resolution graphics monitor for about the same price. This trend in price/performance gradually has brought low-end workstations into the same ballpark as high-end personal computers (PCs)—hence the term “personal workstations.”

In this article, I'll discuss the basic characteristics of a workstation, who uses them, and how. I'll also look at how and where personal workstations fit in with high-end workstations and PCs.

First, a Little History

Workstations actually predate PCs. The direct descendants of 32-bit minicomputers, they first arrived on the computing scene in the late 1970s. The first work-



stations were simply high-resolution graphics terminals connected to multi-user minicomputer systems running mechanical and structural design software used by engineers and mechanical designers. A typical “graphics workstation” cost several thousand dollars and ran on minicomputers costing several hundred thousand dollars, such as the VAX-11/780 from Digital Equipment

Corp. (DEC) or the Prime 750 from Prime Computer. These early workstations typically featured 1000- by 800-pixel 19-inch monochrome monitors, a keyboard, and an input device, such as a mouse or a digitizing tablet. They were used for CADD and for modeling mechanical systems and components.

But these early workstations had a major problem. Because they ran on a host minicomputer, which might have as many as 30 or 40 users simultaneously sharing resources, they were often painfully slow. Engineers would have to wait for hours for their applications to run because they were contending for resources with other engineers, as well as other departments such as accounting and word processing. Another problem with these minicomputer-

based workstations was that they were confined to proprietary operating systems, which limited the availability of third-party software applications and restricted the portability of applications.

The obvious solution to the minicomputer bottleneck was to give graphics workstations their own CPUs, making them independent from the general-

continued

purpose minicomputer system. One way around the proprietary-operating-system problem was to offer stand-alone workstations running Unix, a multitasking operating system in the public domain.

But minicomputer systems also offered one major advantage. You could share files and applications, because all the workstations were connected to the minicomputer. The answer to this on stand-alone workstations was to provide a local-area network (LAN) that allowed workstation users to share files and peripherals.

Apollo Computer was the pioneering manufacturer of stand-alone workstations. Founded in 1980, Apollo's first offering was the Motorola 68000-based Domain DN100, which had a price tag of close to \$60,000 for a fully configured system. A couple of years later, Sun Microsystems entered the workstation market with a competitive Unix workstation called the Sun 100, which was also based on the 68000. The Sun 100 had a 10-MHz 68000 processor, a 1000- by 800-pixel monochrome graphics display, and a six-slot MultiBus card cage. The rated integer performance of the Sun 100 was 0.5 million instructions per second (MIPS). The Sun 100 with 256K bytes of memory, Unix, and Ethernet cost about \$13,000. But a fully configured system with 2 megabytes of memory and an 80-megabyte hard disk drive cost over \$30,000. From the start, Sun Micro-

systems and Apollo have been fierce competitors in the workstation market. Certainly, competition continues to contribute to the favorable price versus performance trend.

Historically, workstations have been one step ahead of PCs. While PCs started off as 8-bit machines, workstations started off on 16-bit processors. They were the first stand-alone machines to be networked, and they offered more advanced graphics capabilities. While early PCs either didn't have graphics at all or had only 640- by 200-pixel black-and-white graphics, workstations came with 1000- by 800-pixel resolution or better. Because workstations were based on Unix, they offered multitasking and large memory management capabilities well before those features were available on microcomputers.

Another important difference in the evolution of conventional workstations and PCs was the software. While the first PC software consisted of games, simple file management programs, and text editors, workstation software migrated from the professional-level applications available in the minicomputer environment. Structural analysis, CAD, graphics design, database management, and page layout provided the core applications on workstations. Not only was this software considerably more sophisticated than the early applications on PCs, it was a lot more expensive. Software

packages usually cost several thousand dollars on a workstation, and they often cost that much today.

But the PC offered something that workstations couldn't match: ease of use and affordability. While workstation users faced the arduous task of learning Unix, PCs offered easier accessibility. Although MS-DOS was no picnic, it certainly seemed that way when compared with Unix. Then the Macintosh desktop began the revolution that forced workstation manufacturers to come up with better graphical interfaces. The NeXT graphical interface may be the first truly easy-to-use Unix-based graphical interface.

The development of good spreadsheet, database, and word processing programs on the PC began to build a bridge between the PC and the workstation. For a few hundred dollars, you could get software on the PC that was functionally superior to the equivalent workstation software costing hundreds or thousands of dollars more. You couldn't get Lotus 1-2-3 or Microsoft Word on a workstation, so workstation users started demanding MS-DOS compatibility. This was the beginning of the bridge from the workstation end. Today, many workstations offer some method to run MS-DOS as a task in the Unix environment (SoftPC from Insignia Solutions and Merge 386 from Locus Computing are examples of products that let you run DOS in the Unix environment).

Workstations Today

The workstations of 1989 are a far cry from the Domain DN100 or the Sun 100 (see "The Current Crop" by Bill Nicholls on page 235). A low-end workstation or a high-end PC—the overlap is fairly complete and the distinction blurred—can now be referred to as a "personal workstation." Today, the personal workstation features a 32-bit processor, at least 4 megabytes of memory, 1024- by 800-pixel screen resolution or better, 4 or 8 bit planes of color, at least 70 megabytes of hard disk storage, and Ethernet and Unix capabilities. It also normally includes a floating-point coprocessor.

Workstations are available in three main bus architectures—VME, MultiBus, and the IBM PC AT bus. Apollo Computer's personal workstations, for example, use the AT bus, while the higher-end machines use VME or MultiBus. Sun Microsystems primarily uses the VME bus but offers the AT bus in its 386i product line. And the NeXT Computer has a NuBus-compatible backplane.



A three-dimensional image displayed on the new Personal Iris from Silicon Graphics. The Personal Iris features an R2000 RISC processor from MIPS Computer and a 1280- by 1024-pixel color monitor.

A typical base system, as configured above, costs around \$12,000. However, costs increase dramatically when you add additional graphics capabilities, such as a graphics accelerator board and additional mass storage. A system costing \$12,000 will rapidly climb to \$30,000 if you add a graphics coprocessor and a larger hard disk drive. The photo at left shows the graphics capability provided on the new Personal Iris workstation from Silicon Graphics. While an entry-level diskless version of the Personal Iris costs about \$16,000, a system with a 170-megabyte hard disk drive and z-buffering (hidden-line removal in hardware) costs over \$30,000 (see Phillip Robinson's article "Art + 2 Years = Science" on page 255). NeXT's personal workstation may have a significant impact on these ballpark workstation costs.

While the initial workstation offerings were based on the Motorola 68000, today's workstations often use the Motorola 68020 and 68030, as do many PCs. Apollo still offers only Motorola-based machines. Sun Microsystems and Prime Computer also offer machines using the Intel 80386, as do many PC companies. Some workstation companies offer machines using reduced-instruction-set-computer (RISC) architecture, and some, notably Sun Microsystems, offer a similar architecture called scalable-processor architecture (SPARC). IBM, Hewlett-Packard, and Silicon Graphics also offer RISC-based workstations.

But because these workstations all run Unix, the type of processor is not that important to the end user. What is important is the performance of the machine and the available software. Integer performance of today's workstations ranges from about 1.5 MIPS for personal workstations to about 10 MIPS for top-of-the-line systems that cost from \$50,000 to \$100,000 (Silicon Graphics has lowered the price/performance ratio even more, claiming a performance of 10 MIPS on its Personal Iris). RISC-based systems generally provide higher performance than the complex-instruction-set-computer (CISC) machines. (For more information on RISC and the various RISC chips, see "Worth the RISC" by Trevor Marshall and Jane Morrill Tazelaar on page 245.) For example, Sun Microsystems claims that the high-end systems in its product line with SPARC processors provide a 7- to 10-MIPS integer performance. Sun's 68020 line of machines offers performance ratings from 1.5 to 4 MIPS, and its 80386-based 386i machines range from 3 to 5 MIPS.

An equally important measure of per-

formance is millions of floating-point operations per second, or MFLOPS. Floating-point performance depends on the type of floating-point processor used in the system. Lower-priced machines with Intel 80387 or MC68881 floating-point processors have a floating-point performance of about 0.2 MFLOPS. Machines with floating-point accelerators have performance ratings ranging from 0.6 to 2 MFLOPS.

However, floating-point accelerators

With
large, high-resolution
graphics monitors, it is
possible to have
multiple windows with
multiple sessions
operating
concurrently.

raise the cost of the system by as much as \$10,000 to \$15,000. Even more expensive floating-point accelerators can provide performance of up to 12 MFLOPS. For example, Sun Microsystems offers an accelerator called the TAAC-1 that claims 25 MIPS and 12.5 MFLOPS performance for \$30,000. (For further discussion of performance metrics, see "How Fast Is Fast?" by Bill Kindel on page 251.)

Who Uses Workstations, and How?

The main users of workstations are still engineers, scientists, architects, and mechanical designers. However, workstations have also become attractive for people who work in the fields of animation, graphics design, and desktop publishing.

A major user community for workstations is the university. The figure on page 232 shows a network of workstations (and also some minicomputers and mainframes) at the University of California at Santa Cruz (UCSC). This system is typical of the workstation environments at many universities. Note that the planetary names on the diagram are the address names of the systems on the net-

work. The polygons surrounding systems on the diagram (e.g., Sol/Daizu) represent groups of diskless workstations and their file servers.

The UCSC system exemplifies some of the features of workstations that distinguish them from PCs. Workstations are almost always networked. Ethernet and Sun Microsystems' Network File System have become the networking standard for many workstations, while others use AT&T's Remote File System. (For a discussion of the relative merits of NFS and RFS, see "Networking with Unix" by Greg Comeau on page 267). Networks allow the use of diskless workstations that can access files from a file server. As UCSC's software manager Al Conrad told me, the idea is to "put computer power on people's desks and the storage in a centralized room." Conrad points out that it is cheaper and more efficient to have a 1-gigabyte hard disk drive that everyone can use than it is to have 10 100-megabyte hard disk drives carrying duplicate applications.

Another feature of the UCSC system is that it runs Unix. Machines on the network run everything from 4.3 Mach Unix to System V.2 to Xenix. As long as you're in character mode, applications are quite portable between the various Unix versions, according to Conrad. However, incompatibilities exist between the various Unix window managers and interfaces, such as NeWS, X11, and proprietary window managers like Suntool or the Macintosh environment. All these windowing systems run on the UCSC network. The Macintoshes are linked to the system via Kinetics' interface between AppleTalk and TCP/IP.

Two important requirements for personal workstations are that they have at least 4 megabytes of memory and that they can use high-resolution graphics monitors displaying close to 1 million pixels on the screen (*megapixel* displays). There are several reasons for these two requirements. Perhaps the most important of these is multitasking, one of the main attractions of Unix. In conjunction with large, high-resolution graphics monitors, you can have multiple windows with multiple sessions operating concurrently. But you need a lot of memory to run multiple sessions simultaneously—the more the better.

A multitasking windowing environment greatly improves productivity. Programmers can work on multiple subroutines or program modules simultaneously. Writers can view and work on multiple documents at the same time.

continued

And users can access multiple nodes on the network simultaneously, each window corresponding to a different session with a different network node.

High-resolution graphics are an essential component of workstations. Most have 1-megapixel (approximately), 19-inch monitors, which provide not only excellent windowing capabilities but also the resolution necessary for CAD and graphics design. High-resolution graphics capabilities also are available on PCs, of course; the standard for PCs is still around 640 by 480 pixels, while the standard for workstations is 1 million pixels. Color is just starting to become standard on workstations—until recently, most

workstation graphics monitors were monochrome or gray-scale.

Workstations require a lot of memory because of the types of applications they run. Consider the requirements for the computations performed in finite-element-analysis problems, for example. Finite-element analysis and other engineering software require the solution of simultaneous equations. A small finite-element model with only 200 degrees of freedom (the number of variables defining the displacement of the model) requires solving a 200 by 200 array of simultaneous equations. A fully populated 200 by 200 array contains 40,000 coefficients. Because these types of problems

require a high degree of accuracy, the coefficients are represented in double-precision, requiring 8 bytes per coefficient. So, this small problem requires 8 bytes multiplied by 40,000, or 320,000 bytes of memory. Many finite-element problems involve two or three thousand degrees of freedom. If you wanted to solve a 1000 by 1000 array of simultaneous equations, you would need 8 million bytes of memory in addition to the memory required for the applications software and the operating system.

Most finite-element programs do not require that the entire array fit into the main memory of the computer. They get around the memory limitations by swap-

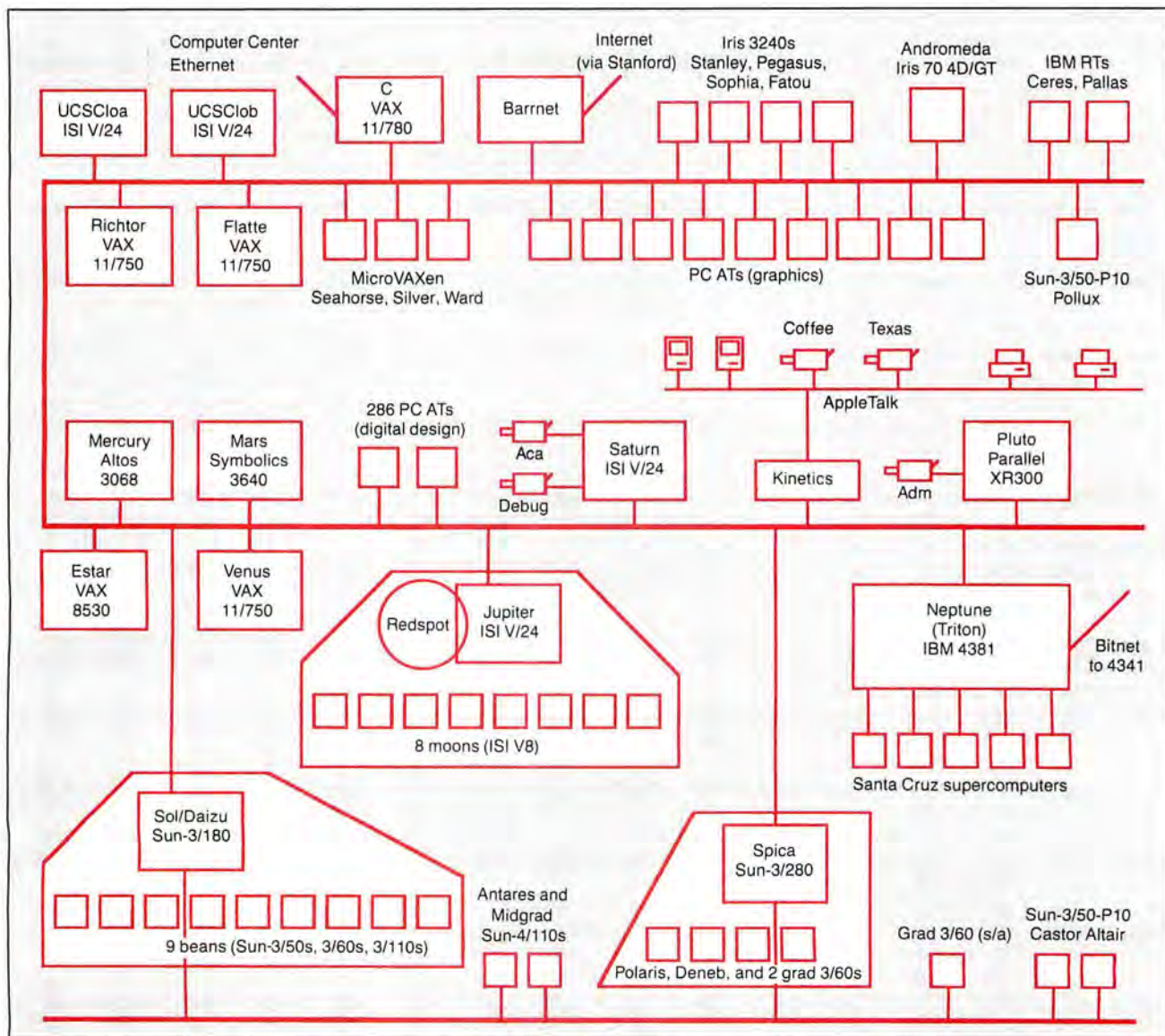

The Ethernet network at the University of California at Santa Cruz (UCSC). Note that the planetary names represent addresses on the network. Groups of machines enclosed by polygons represent diskless nodes and their file servers. (Figure courtesy of the Computer and Information Sciences department, UCSC.)

SAVE \$17



Subscribe to BYTE now and save \$17 off the newsstand price of \$42.00... and \$5.00 off the regular subscription rate of \$29.95. You'll also receive our special IBM PC issue as part of your subscription.

USA \$24.95/1 year Canada \$26.95 U.S./1 year

Bill me

Payment enclosed

Charge to my VISA MasterCard

Account # _____

Expires _____

Signature _____

This is a renewal order.

IBJ5393

Name _____
(Please Print)

Company _____

Address _____

City/State _____

Country _____ Code _____

For direct ordering, call toll free 1 800 257-9402 weekdays
9:00 AM-5:00 PM EST. In New Jersey, call 1 609 426-5535.

Please allow 6-8 weeks for processing your subscription.



SAVE \$17



Subscribe to BYTE now and save \$17 off the newsstand price of \$42.00... and \$5.00 off the regular subscription rate of \$29.95. You'll also receive our special IBM PC issue as part of your subscription.

USA \$24.95/1 year Canada \$26.95 U.S./1 year

Bill me

Payment enclosed

Charge to my VISA MasterCard

Account # _____

Expires _____

Signature _____

This is a renewal order.

IBJ5393

Name _____
(Please Print)

Company _____

Address _____

City/State _____

Country _____ Code _____

For direct ordering, call toll free 1 800 257-9402 weekdays
9:00 AM-5:00 PM EST. In New Jersey, call 1 609 426-5535.

Please allow 6-8 weeks for processing your subscription.





NO POSTAGE
NECESSARY
IF MAILED
IN THE
UNITED STATES

BUSINESS REPLY MAIL

FIRST CLASS MAIL PERMIT NO. 42 HIGHTSTOWN, NJ

POSTAGE WILL BE PAID BY ADDRESSEE

BYTE

Subscription Department
P.O. Box 558
Hightstown, N.J. 08520-9409



NO POSTAGE
NECESSARY
IF MAILED
IN THE
UNITED STATES

BUSINESS REPLY MAIL

FIRST CLASS MAIL PERMIT NO. 42 HIGHTSTOWN, NJ

POSTAGE WILL BE PAID BY ADDRESSEE

BYTE

Subscription Department
P.O. Box 558
Hightstown, N.J. 08520-9409



ping parts of the array to and from disk. However, the more memory you have, the faster you can solve large arrays. Several finite-element programs run on IBM PCs with 640K bytes of memory. However, solving large problems can take all night on a machine that size. Workstations offer two major advantages for finite-element analysis: multitasking and much larger memory capacity. Both capabilities are also available on personal workstations. Even if you're running a long, time-consuming problem on a workstation, you can run it as a background task and continue working in other sessions on the computer.

Large mass-storage capability is another important requirement of personal workstations. Applications that need a lot of memory usually require a fair amount of disk space. Again, finite-element analysis is a good example. A large finite-element problem of several thousand degrees of freedom can easily take up 20 megabytes of disk space. In addition, operating systems and applications continue to grow rather than shrink. For example, Apple's A/UX is shipped on an 80-megabyte hard disk, of which 70 megabytes are taken up by the system software. And the NeXT Computer is shipped with a 250-megabyte optical drive that is already two-thirds full.

However, mass storage isn't an absolute requirement for workstations. You can have diskless workstations accessing a file server, which provides the hard disk drives and the tape backup. The diskless-node-and-file-server model makes an awful lot of sense in a network of workstations. This type of system is more efficient, and it also eliminates the storage of redundant data. In addition to hard disk storage, a workstation environment usually includes tape backup. In a network of diskless workstations, the tape backup system is part of the file server.

Workstations vs. PCs

Until OS/2 becomes widely used, multitasking will remain fairly limited on PCs. Without shared memory and inter-process communications, the multitasking that you can do with, say, DESQview is quite limited in comparison to the flexibility of Unix multitasking environments. DESQview is restricted to 640K bytes of main memory and a 128K-byte window into expanded memory, which limits the performance and the size of multitasking applications. It could also be argued that the cooperative multitasking environment of the Macintosh MultiFinder is not as robust or well developed

as the preemptive multitasking model used in Unix (see Phil Goldman's article entitled "MultiFinder Revealed" in the *Macintosh Special Edition*, August 1988 BYTE).

If you take a look at the components of the typical workstation, it is clear that they include both the low-end workstation, like the NeXT machine and the Sun386i, and the high-end PC, like the IBM PS/2 Model 80 or the Macintosh II. These machines have 32-bit processors

Mass

*storage isn't an
absolute requirement
for workstations.
Diskless workstations
can access a file server
with hard disk and
tape backup.*

and floating-point coprocessors and can support at least 4 megabytes of memory. You can buy them with big hard disk drives, Ethernet, a version of Unix (Santa Cruz Operations' Xenix, AIX from IBM, or A/UX from Apple), high-resolution graphics, and so on. For example, UCSC uses Rose Hill Systems AT-386s equipped with 24 bit-frame buffers for instruction in graphics. As you can see in the figure, these machines are linked into the network just like any other workstation.

So what, exactly, is the difference between workstations and PCs? The distinction is largely cultural. PCs evolved primarily in the business and home markets, while workstations evolved in the engineering and mechanical-design markets and in the research environment of academia. MS-DOS and the Macintosh Finder were not designed for use in engineering; they were designed for business and home users. Unix, on the other hand, has traditionally been an operating system for academic and scientific computing. It was designed to support multitasking and multiple sessions, and workstations were built from the ground up to run Unix.

A Melding Pot

As we approach the 1990s, the distinction between workstation and PC is becoming less and less obvious. The NeXT Computer is an excellent example of the fading distinction. It is in every respect a workstation (with the exception of its lack of color capability). And, as Steve Jobs put it, the NeXT Computer "raises the lowest common denominator" for computing.

Soon, the only way we'll be able to tell the difference between traditional workstations and PCs will be by the operating system they run. Workstations will continue to run Unix and use Ethernet with NFS or RFS. PCs will run OS/2 or a Macintosh operating system. They will use Microsoft and 3Com's LAN Manager, Banyan Systems' VINES, Novell's NetWare, or AppleTalk. And personal workstations? At least some of them will be able to "switch hit."

Multitasking, networks, and high-resolution graphics are gradually becoming requirements in the business world. Business users want large, high-resolution displays with multiple windows. They want networked systems with access to large file servers. And they want multitasking to perform multiple tasks simultaneously. So, although PCs and workstations come from different backgrounds and serve different users, they are rapidly converging.

Without a doubt, the price/performance ratio for computing power will continue to drop. With a "university price" of \$6500 for an 8-megabyte machine with a 1-megapixel display, 250 megabytes of mass storage, and Ethernet built in, the NeXT Computer will almost certainly force other companies to deliver less expensive and more capable machines (for a detailed look at NeXT's machine, see "The NeXT Computer" by Tom Thompson and Nick Baran, November 1988 BYTE). Sun Microsystems, for example, is expected to announce some new lower-cost personal workstation entries in 1989, and we can expect competitive Unix-based personal workstations from traditional microcomputer manufacturers like Apple and IBM. ■

ACKNOWLEDGMENT

I would like to thank Al Conrad of the Computer and Information Sciences department at UCSC for his help in preparing this article.

Nick Baran holds a BSME from Stanford University and is a BYTE senior technical editor based in San Francisco. He can be reached on BIX as "nickbaran."

STOP

and compare our quality and prices!

Our Standards Are Their Options...

42+ Meg 12 MHz 286 EGA Color System **\$1850**

- Samsung 14" EGA Color Monitor
- 12 MHz PC-AT Computer
- Baby AT Case with Key Lock, Turbo, Power and Hard Drive LEDs
- Everex Enhanced Auto Switch EGA Card 640 x 480
- Intel 80286 CPU
- Multi-speed 6/8/10/12 MHz
- Keytronics 101 Enhanced Keyboard
- 640k Memory Expandable to 1 Meg
- 200 Watt Power Supply
- Seagate Model ST251 42+ Meg Hard Disk Drive
- 5¼" 1.2 Meg Floppy Drive
- Western Digital 2 Hard Disk and 2 Floppy Controller with Cables
- Serial/Parallel & Game Port
- 80287 Math Co-Processor Slot
- Complete Operations Manual
- One Year Warranty

With EGA Multisync (Analog) 800 x 560 **\$2045**
 With Monochrome + 40 Meg (ST-251) **\$1495**



286 16 MHz 0 Wait State Running at 21.0 MHz

42+ Meg 16 MHz 286 EGA Color System **\$2250**

Same System as Above with the Following Differences:

- Running at 21 MHz
- 0 Wait State
- 16 MHz PC-AT Computer
- Multi-speed 8/16 MHz
- Landmark Test of 21 MHz
- 1 Meg Memory Expandable to 8 Meg on the Motherboard

With EGA Multisync (Analog) 800 x 560 **\$2445**
 With Monochrome + 40 Meg (ST-251) **\$1895**

42+ Meg 20 MHz 386 EGA Color System **\$2995**

- Samsung 14" EGA Color Monitor
- 20 MHz 0 Wait State Computer
- Everex Enhanced Auto Switch EGA Card 640 x 480
- AT Case with Key Lock, Turbo, Power and Hard Drive LEDs (Tower Case available)
- Intel 386-20 CPU (not a 386-16)
- Keytronics 101 Enhanced Keyboard
- 1 Meg Memory
- 220 Watt Power Supply
- Seagate Model ST251 42+ Meg Hard Disk Drive
- 5¼" 1.2 Meg Floppy Drive
- Western Digital 2 Hard Disk and 2 Floppy Controller with Cables
- Serial/Parallel & Game Ports
- Math Co-Processor Slot
- Complete Operations Manual
- One Year Warranty

With 386-20 MHz EGA Multisync (Analog) 800 x 560 **\$3190**

DOS 3.3 — \$79
DOS 4.0 — \$109

To Order, Call

1-214-931-3777

**ALL SYSTEMS ALSO
AVAILABLE WITH VGA**

ieee, inc. 17120 DALLAS PARKWAY • SUITE 212 • DALLAS, TEXAS 75248

TERMS: One year warranty (12 months parts/12 months labor). 30 day money-back guarantee (excluding shipping charge). We accept **Visa, MasterCard, Discover** (add 3% for credit cards), cashier's check, money order, wire transfer and personal checks (personal checks, please allow 10 working days to clear). Shipping and insurance extra. Prices and availability subject to change without notice. IEEE reserves the right to substitute equivalent or better products. No COD's accepted. 15% restocking fee on unauthorized returns. IBM XT/AT are trademarks of IBM Corporation. **HOURS: (Central Time) 9 a.m. to 7 p.m. Monday through Friday, 9 a.m. to 5 p.m. Saturday.**

M E M B E R — D A L L A S C H A M B E R O F C O M M E R C E

The Current Crop

Buying a workstation has its benefits—but building your own on a PC base is also a valid option

Bill Nicholls

workstation is the Ferrari of the personal computer world. Most of us have seen one and occasionally watched one in use, but in general, we know little about them beyond the mystique they carry. Unlike the Ferrari, however, the price of workstations is coming down due to improvements in semiconductor technology. Also unlike the Ferrari, many of us are likely to get better acquainted with workstations in the near future.

What is a workstation? Is there really a difference between a workstation and a personal computer? What can you find for under \$20,000? When I went looking for answers to these questions, I was in for some surprises. Despite the history and advertising for workstations, the differences between low-end workstations and high-end personal computers no longer outweigh the similarities. In fact, their capabilities have become so similar as to blur the distinction between the two. They can, effectively, be grouped together as "personal workstations."

I found three major areas of differentiation between personal computers and



workstations: design, networking, and graphics. The design issue is the most central. Workstations are designed as integrated products, tools with which to perform useful work. They avoid the "fill-in-the-blanks" approach to system configuration that the personal computer arena has carried to extremes. Workstation designs also recognize that work is rarely done in isolation and so provide

a level of networking that would make the most ardent local-area network admirer jealous. Finally, workstation design responds to the need for people to interact and control the system, and it accomplishes that through an intuitive graphical interface.

In the recent past, it would not have been possible to buy all those features separately. Today, with attention to detail, you can come quite close to the workstation-design philosophy. Current 80386-system designs from Compaq and Advanced Logic Research (ALR) address the memory-performance issue, Ethernet and Transmission Control Protocol/Internet Protocol (TCP/IP) are available as the base network, and high-performance graphics are available from many companies like Matrox, Renaissance, and Number Nine.

Building a Workstation

I'm actually in the process of building my own workstation, although it's not what I started out to do (see the text box "From PC to Workstation" on page 236). My original objective was to upgrade the AT clone I was using to an

continued

From PC to Workstation

Seven years ago, I bought my first microcomputer. It was a Radio Shack Model 3 with only 16K bytes of memory and no disk drives, but I did use it. Three weeks later, I upgraded it to the maximum of 48K bytes of memory. Three years later, I bought a Sanyo 555: 128K bytes of memory and two single-sided disk drives. This rapidly became a 256K-byte system with 360K-byte drives, almost IBM PC-compatible. These early machines were distinctly underpowered, and the mass storage and display arrangements were primitive, but with patience and persistence, I could do my work.

With my next machine, an 8-MHz XT clone, I began the transition to machines that worked for me, rather than the reverse. Upgrades followed rapidly over the next years to my current ALR 386/220, a 20-MHz 80386 system with

3 megabytes of memory, running Unix System V 3.0. Except for a large graphics display, a network, and a few design refinements, this system has the attributes of a workstation. I didn't start out intending to build a workstation but simply progressed toward systems with better support for my work.

The relevance of this history is that while the functions I perform are mostly unchanged—writing, programming, keeping track of things, doing calculations—the *style* of my work has evolved. Rather than wait for the system, it waits for me, and it improves my ability to respond by enabling quick task switching and multitasking when needed. I have traded machine cycles (and cost) for my time and come out ahead in productivity. With some further investment in graphics and network hardware, I would have a complete workstation.

80386 and migrate to Unix, connecting a few terminals. I chose an ALR 386/220, a 20-MHz system with two-wait-state memory for reliability and cost/performance. The Unix System V 3.0 software (from Bell Technologies) requires 2.5 megabytes of memory to install, but only 2 megabytes to run. I already have a large disk drive (160 megabytes) and a fast controller. The basic system with 3 megabytes of memory was easy to put together—but not inexpensive.

Currently, I'm using an EGA/CGA display combination. My original plan was to install a VGA display, but experience with workstations has made me reconsider, and I'm looking at the larger graphics displays with a large monochrome monitor (color is too expensive), supported by the new X Windows standard. The ability to work with multiple windows on a high-resolution screen is a major productivity tool. These display systems are available from 640 by 480 pixels by 8 bit planes up to 2000 by 2000 pixels by 8 bit planes in color or monochrome.

The final piece of the workstation environment is the network. This choice is easier, as the standards are Ethernet and TCP/IP. The only caution here is to verify that the software and hardware are compatible with your machine. If I were to link with another Unix system with a hard disk drive, I would add RFS, the Remote File System software, which allows

me to access the other files as though they were local, subject to the permission of the other system.

Some other choices are modified by building a workstation. One is the tape backup system. Unix does not (yet) support tape systems driven from the floppy disk drive controller, so I am about to replace my inexpensive DC-2000 system with one that is supported, with either 60-megabyte or 125-megabyte tape cartridges. Both use the larger DC-600A tape cartridge. Memory choice is simple—as much as you can afford. Unix systems will run with as little as 2 megabytes but really begin to hum at 4 megabytes. For multitasking or graphics, 8 megabytes would be nice.

The effect of too little memory is a large increase in paging and swapping to the hard disk, and a noticeable reduction in performance. Unix is disk-intensive, and the faster the disk, the better Unix performs. In retrospect, the extra cost of an enhanced-small-device-interface disk with its higher transfer rate would have been a good investment.

Buying a Workstation

Unlike the personal computer's "do-it-yourself" approach, a workstation as such comes with all the essential hardware and software you need to make it function. Only customization and vertical applications are left for you to add. Some applications may require network

support rather than include a separate disk, but that reflects on the way a group, rather than an individual, works. All the basic workstation systems have similar components.

Buying a standard workstation has its benefits, because the platform starts with a larger minimal configuration. This simplifies the software requirements by reducing the number of variables and eliminating configurations that restrict workstation performance. It also offers certain economies of scale by providing as standard certain equipment that would otherwise require extra room to add later. In particular, workstations all start with a reasonable (for today) 4 megabytes of main memory; in a personal computer, this requires substantial expansion. Network interface and graphics displays also benefit from being standard.

Another workstation design goal was to create a group working environment that is smooth, seamless, and fast. This was implemented with an integral network, a noticeable difference from the original personal computer as a stand-alone system. The standard Ethernet and TCP/IP have now become easily available for personal computers, reducing that gap.

One issue, that of operating systems, remains. While the personal computer has evolved with MS-DOS and is slowly adopting OS/2, workstations have always used a multitasking operating system. When Apollo began, it provided Aegis, but subsequent workstation development has made Unix a standard. Working between Unix and OS/2 is still awkward. However, the high-end personal computers have now grown into machines quite capable of running Unix, and in fact such systems exist (e.g., Apple's A/UX and IBM's AIX).

A Personal Workstation

Most vendors' lines of workstations start at the low end with the same general level of hardware and software that the high-end personal computers have. The hardware for these "personal workstations" now includes a fast 32-bit microprocessor, 4 to 8 megabytes of memory, a 15- to 19-inch graphics display, a fast network (typically Ethernet), and a large hard disk drive, either attached or on the network (see table 1).

Software may be a proprietary operating system but is more likely to be Unix with graphics and network extensions (see table 2). The difference between a workstation and a personal computer

continued

Power Up Your Compaq 386!

Take it to the limit with Clearpoint high-performance memory



Introducing Clearpoint's
4 MB COMRAM

Order today and get

- Competitive Prices
- Fast Delivery
- Lifetime Warranty
- 24-Hour-a-Day Service

The COMRAM

Compaq 386-Compatible Memory

From the largest manufacturer of workstation memory comes the best four megabyte memory for the Compaq - Clearpoint brings you the COMRAM for your DESKPRO 386/20 or 386/25.

Manufactured to Clearpoint's stringent production and testing standards, you are assured of optimal performance with our combination megabit DIP and SOJ design. Take your 386 to its 16 MB limit by adding three Clearpoint COMRAM boards to your 4 MB motherboard. We guarantee fast delivery, plus the best package of reliability and service.

Clearpoint is a registered trademark of Clearpoint Research Corporation. Macintosh and Mac are trademarks of Apple Computer, Inc. DEC and MicroVAX 2000 are trademarks of Digital Equipment Corporation. Sun is a trademark of Sun Microsystems Inc. DN 3000, DN 3500, and Apollo are trademarks of Apollo Computer. COMPAQ and DESKPRO are registered trademarks of Compaq Computer Corporation.

Clearpoint Guarantees Lifetime Warranty

With the strictest dynamic and thermal testing in the industry, Clearpoint confidently offers a lifetime warranty—Then backs it up with a 24-hour Repair/Replacement policy and an 800 service number for a warranty with teeth.

Superior Memory Design

Across the board, Clearpoint brings the workstation marketplace better memory design. Whether it's higher density or state-of-the-art DRAM technology—Clearpoint designs it better.

Guaranteed Buyer Satisfaction

Long-term satisfied customers is Clearpoint's goal. With comprehensive, user-friendly documentation, trade-up credits and competitive pricing, Clearpoint guarantees buyer satisfaction.



CLEARPOINT

Other Clearpoint Workstation Memory

MACINTOSH

MC2RAM (compatible with the Macintosh II, SE and Plus) 1 MB SIMMs.

SUN

SNXSM (compatible with Sun 3/60): Available in 1 MB SIMMs, four in a set.
SNXSC (compatible with Sun 4/110 and 386i): 1 MB SIMMs.

DEC

DCME-M20 (compatible with the MicroVAX 2000): 8 and 16 MB boards.

APOLLO

DNXRAM (compatible with the DN 3000): 1 and 2 MB boards.

Call or write for a
COMRAM Product
Marketing Update,
a free catalog, and
our Memory Pointers
newsletter.



Dealer Inquiries Invited.



Credit
Card
Orders
Accepted

Circle 259 on Reader Service Card

Clearpoint Research Corporation, 99 South Street, Hopkinton, MA 01748
1-800-CLEARPT (1-800-253-2778) or 508-435-2000

Table 1: A representative sample of workstations below \$20,000 listed in ascending-price order.¹ Notice the location of my "build-your-own" workstation project using the ALR 386/220.

System	Processor and clock speed	MIPS	FPU and clock speed	Memory (megabytes)	Display size (pixels)	Disk capacity (megabytes)	Price
Apollo DN3000	68020-16	1.5	68881-16	2-8	1024×800	0-696	\$4990
Sun-3/50	68020-15	1.5	68881-15	4	1152×900	71-1300	\$4995
NeXT	68030-25	4	68882-25	8-16	1120×832	256-926	\$6500
ALR 386/220 ²	80386-20	3.5	80387-20	1-10	640×480	67-320	\$7695
Sun386i/150	80386-20	3.5	80387-20	4-16	1024×768	91-981	\$7990
Sun-3/60	68020-20	3	68881-20	4-24	1152×900	71-1300	\$8900
Apollo DN3500	68030-25	4	68882-25	8-32	1024×800	0-696	\$8990
Sun386i/250	80386-25	5+	80387-25	4-16	1024×768	91-981	\$11,990
SGI Personal Iris	R2000A-12	10	Optional	8-16	1280×1024 ³	155-2000	\$16,000
Sun-4/110	SPARC-14	7	1164/1165	8-32	1152×900	141-1300	\$18,900
Apollo DN4500	68030-33	7	68882-33	8-32	1280×1024	155-696	\$18,990

¹ Unless otherwise noted, all workstations are configured as follows: RAM is 4 megabytes of fast 32-bit memory; all monitors are monochrome; floating-point chips are included; graphics processors are not included; Ethernet with TCP/IP is the standard network interface; and standard software is Unix with a full set of Unix tools.

² The ALR 386/220 has an optional 80387 chip and an optional VGA controller/multiscan display plus 2 megabytes of memory expansion included in the price.

³ The SGI Personal Iris has a color monitor with 8 bit planes and a graphics processor included.

Table 2: The software environments for the workstations in table 1.

	Apollo	Sun	SGI	NeXT
Operating system	Aegis or Unix SV or Unix BSD	SunOS (Unix) and MS-DOS	IRIX (Unix)	Mach (Unix)
Network software	Domain/OS	NFS	NFS	TCP/IP
Graphics software	PHIGS	SunCGI SunGKS	SGI Graphics Library PHIGS ²	None at press time
Development tools (in addition to standard Unix tools)	Open Dialogue User Interface Management System ² ; Domain Software Engineering Environment ² ; Domain/OS Debugger	For 386i: SunView; X11/NeWS Merge; Help Viewer	Developer's Option Package: Graphics Library, EDGE (graphical debugger), Pixie (profiler)	Objective-C Interface Builder; DSP Library Functions; PostScript Window Server
Bundled applications (in addition to standard Unix applications)	None	Sun Organizer desktop file manager	QuickPaint; QuickModeler; IRIS Work Space; IRIS Graphics Library Runtime; 4Sight Windowing System	WriteNow Find Webster's dictionary and thesaurus; Shakespeare's complete works; The Oxford Dictionary of Quotations; Mathematica; Personal Text Database; Application, Sound, and Music Kits
Third-party applications	Spring 1988 Summary of Applications Catalog lists 925 software and hardware products in 26 application areas	Catalyst catalog lists over 1200 products from more than 500 vendors	Silicon Graphics Geometry Partners lists 75 products in 16 categories	None at press time

¹ The ALR machine comes with Setup and some MS-DOS utilities. Since no other software is bundled, the operating system and applications must be bought separately.

² Optional.

based on the same chip lies in the software and in some design choices for higher performance within the system hardware.

The situation changes as you go up the workstation line. Midrange workstations use reduced-instruction-set-computer (RISC) chips at 7- to 10-MIPS (million instructions per second) performance; optional graphics processors are available, as well as large memory and disk drive sizes. High-end workstations include graphics processors and offer multiple processors for a top-end performance of 80 to 100 MIPS.

Apollo

Apollo Computer, formed in 1980, was the first of the workstation vendors. At that time, the concept of a workstation was new, and what Apollo did was to essentially invent the workstation market. Keys to that invention were a new operating system, Aegis, a networking scheme

called Domain, and a token-ring network to support the Domain system.

Although those early workstations were less powerful than some current personal computers, the true attributes of a workstation showed—an integrated network, shared resources, and a graphical interface. Apollo identified the workstation market as a workgroup, using shared resources and data sharing as key concepts, with the objective of delivering mainframe power and workgroup cohesiveness.

Apollo systems have grown from the original 0.2-MIPS Domain DN100 in 1980, based on the 68000, to the newest RISC-based DN4500, which is rated at 7 MIPS. During that same time, workstation prices came down from \$60,000 for the 0.2-MIPS DN100 to about \$5000 for an entry-level DN3000 at 1.5 MIPS. The high end of the Apollo line grew just as quickly—today, the top-end Apollo DN10000 ranges from \$60,000 to \$200,000 and from 36 to over 100 MIPS.

The entry-level DN3000 is no longer a personal-computer killer. The Mac II (2 to 3 MIPS) and 80386 (3 to 6 MIPS) machines have topped the DN3000's 1.5 MIPS on a performance basis, and they are now available with other workstation attributes, such as large graphics displays, hard disk drives, and network connection. While personal computers have advanced, so has Apollo by introducing the 4-MIPS DN3500 (see photo 1), based on a 25-MHz 68030/68882, and the 7-MIPS DN4500, based on the 33-MHz 68030/68882 combination.

The DN4500 uses a 64K-byte cache, interleaved memory, and zero-wait-state operation for maximum performance. For up to a 300 percent floating-point performance increase, a floating-point accelerator using the Weitek 3164 chip is available for the Series 3500, 4000, and 4500. Both 3500 and 4500 systems also can add a high-performance color graphics option with a dedicated graphics processor. This processor optimizes two-dimensional primitive operations on a 1280- by 1024-pixel by 8 bit-plane color display.

Apollo continues to advance its software and now offers the ability to network with a combination of Aegis and one of two variants of Unix: System V R3 or Berkeley Unix 4.3. Apollo can also bridge the gap to MS-DOS by running MS-DOS applications in an Apollo window. The Apollo Domain Network Computing System (NCS) carries the file-sharing concept a step farther. NCS allows users and programs to request un-

continued

ALR¹

MS-DOS
Unix
OS/2
TCP/IP
(with Unix)
None
None
None

Any available for standard Unix, OS/2, or MS-DOS

MAIL PREFERENCE SERVICE

In today's fast-paced society, shopping by mail or phone has become a popular, time-saving way to purchase many products and services. Most people enjoy receiving catalogs and other direct advertising, informing them of what's available through the mail.

You can obtain a free booklet called "Shopping at Home: A Consumer Guide" by sending your name and address to the Consumer Services Department of the Direct Marketing Association. The booklet provides the necessary information to make informed purchase decisions.

However, some people are not interested in receiving advertising mail and the Direct Marketing Association's Mail Preference Service (MPS) offers a free name removal service to consumers. Many companies participate because it's good business to send their message to people interested in their product. Recently, it has been enhanced to include non-profit organizations. You can specify which lists you would prefer to be removed from — commercial and/or non-profit.

So, if you wish to have your name deleted from many national advertising mailing lists, send us the coupon below and we'll let the participating mailers know. After several months, MPS should greatly reduce the amount of national advertising mail you receive. However, many local businesses and community organizations are not participants and will continue to send direct mail. In these cases, your name can be removed from their mailing list by writing directly to the mailer.

Name _____	
Street _____	Apt. _____
City _____	
State _____	ZIP _____
Variations of my name _____	

MAIL PREFERENCE SERVICE
Direct Marketing Association
6 East 43rd Street
P.O. Box 3861 Grand Central Station
New York, NY 10163



Photo 1: The Apollo DN3500, a 4-MIPS workstation for \$8990.



Photo 2: The Sun386i/150, a 3.5-MIPS workstation for \$7990.

used CPU resources from anywhere in the network to perform parts of a task for one workstation. NCS is intended as an open system with source licenses available, and it runs on the major network protocols.

Apollo continues to hold its software edge but has also become one of the founders of the Open Software Foundation (OSF). Seven major computer manufacturers formed this foundation to offer a standard software environment based on X/Open and POSIX specifications. POSIX is an IEEE operating-system standard that is closely related to Unix.

OSF is a nonprofit, industry-supported R&D organization. Its objective is to provide a standard operating environment for applications that will make it easier for users to mix and match computers and applications from different vendors. OSF will address the portability of software, the interoperability of hardware, and scalability, the ability to use the same environment and software on anything from personal computers to supercomputers. The specifications will be public, and OSF will license its software internationally.

Sun

Sun Microsystems, formed in 1982, was the second vendor to specialize in workstation products. Recognizing a gap between personal computers and minicomputers, it took a different approach from Apollo. Sun chose to build "open systems" on existing or emerging standards, or in some cases, to originate new implementations and propose their adoption and licensing to anyone who wanted them. Sun's objective was to integrate current technology and provide better price/performance without locking the customer into a proprietary environment.

Building on the Unix and Ethernet standards, Sun added a high-resolution graphical interface and implemented the Network File System (NFS) as the glue that held together different systems on the same network. Sun describes its environment by saying "the network is the computer" and has software that ties together heterogeneous systems.

Since September 1985, Sun has introduced a series of new systems: the 3/160 at 2 MIPS, and the 3/50 and the 3/260 in 1986 at 1.5 and 4 MIPS, respectively. In July 1987, Sun introduced the 3/60 at 3 MIPS and its first RISC-based system, the 10-MIPS 4/260. As of late fall 1988, Sun has added the 4/110 and 4/150 RISC machines at 7 MIPS, and the 386i/150 (see photo 2) and 386i/250 at 3.5 and 5

continued

Buy with

Confidence

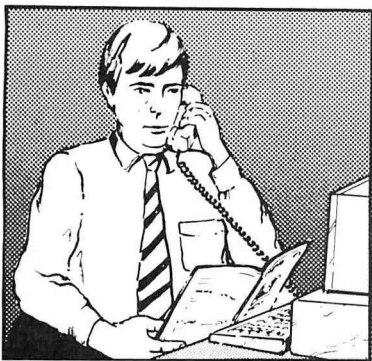

In an effort to make your telephone purchasing a more successful and pleasurable activity, The Microcomputer Marketing Council of the Direct Marketing Association, Inc. offers this advice, "A knowledgeable buyer will be a successful buyer." These are specific facts you should know about the prospective seller before placing an order:

Ask These Important Questions

- How long has the company been in business?
- Does the company offer technical assistance?
- Is there a service facility?
- Are manufacturer's warranties handled through the company?
- Does the seller have formal return and refund policies?
- Is there an additional charge for use of credit cards?
- Are credit card charges held until time of shipment?
- What are shipping costs for items ordered?

Reputable computer dealers will answer all these questions to your satisfaction. Don't settle for less when buying your computer hardware, software, peripherals and supplies.

Purchasing Guidelines

- State as completely and accurately as you can what merchandise you want including brand name, model number, catalog number.
- Establish that the item is in stock and confirm shipping date.
- Confirm that the price is as advertised.
- Obtain an order number and identification of the sales representative.
- Make a record of your order, noting exact price including shipping, date of order, promised shipping date and order number.

If you ever have a problem, remember to deal first with the seller. If you cannot resolve the problem, write to MAIL ORDER ACTION LINE, c/o DMA, 6 E. 43rd St., New York, NY 10017.

This message is brought to you by:

the MICROCOMPUTER
MARKETING COUNCIL
of the Direct Marketing
Association, Inc.
6 E. 43rd St.,
New York, NY 10017

MMC
MICROCOMPUTER
MARKETING COUNCIL
of the Direct Marketing Association, Inc.

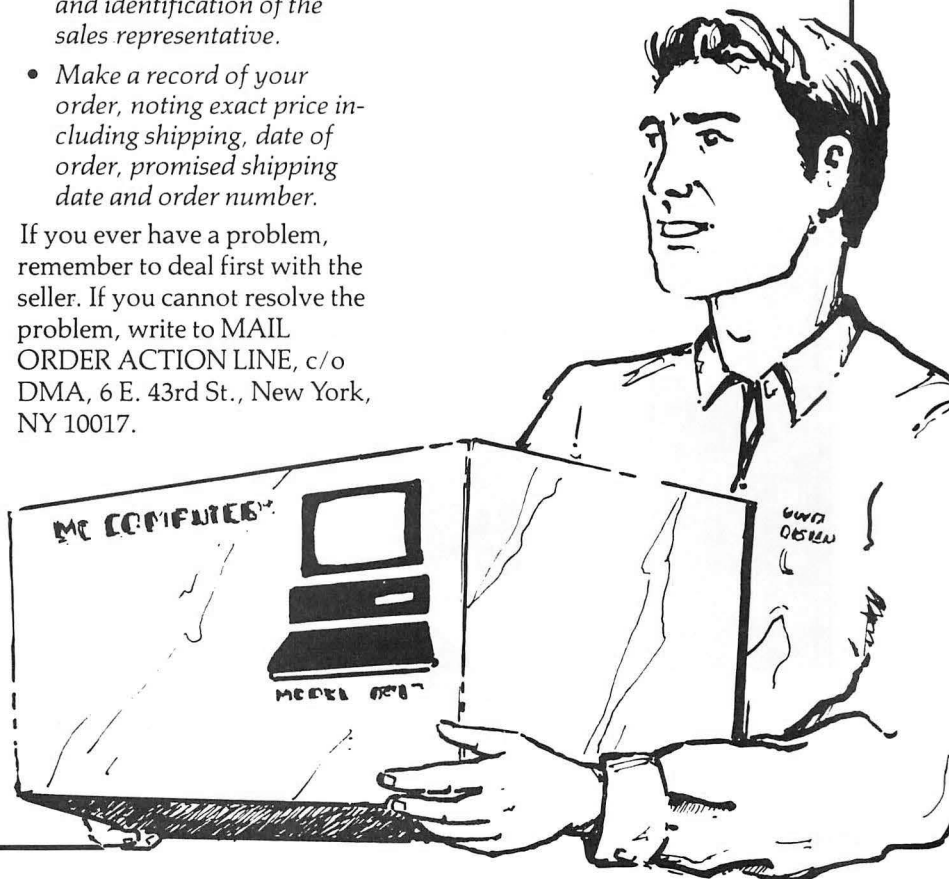

MIPS, respectively, as the first workstations based on the Intel 80386 chip.

Currently, the Sun line ranges from 1.5 to 10 MIPS across three processor architectures—the original Motorola 68020, the SPARC chip, and the Intel 80386. This is a direct result of Sun's philosophy of taking the best current technology and packaging it in a cost-effective manner. Prices range from \$4995 for the base 3/50 to \$39,900 for the 4/260.

In addition to the basic workstation, Sun also offers four graphics accelerators and one floating-point accelerator, the TAAC-1. The TAAC-1 offers 25-MIPS and 12.5-MFLOPS (million floating-point operations per second) computing capability with its own C compiler and libraries for \$30,000. The graphics accelerators can handle from 65,000 to 200,000 two-dimensional vectors per second, double-buffering, and z-axis buffering. All this extra performance comes at a price, however, ranging from \$32,900 to \$59,400. These particular additions aren't likely to be on everybody's desk.

Sun's software is guided by the Open Systems Network philosophy. Sun offers a wide range of networking in the Open Network Computing environment. More than 120 licensees have adopted the Remote Procedure Call and External Data Representation for network services. The ONC environment includes NFS, which allows network-wide file access; the Yel-

low Pages, which provides a directory of services; and Remote Execution, which offers the ability to run applications on other workstations.

Sun also supports access to the network by IBM PCs and compatible systems through PC-NFS, allowing full personal computer sharing with Unix, VMS, and other operating systems. The non-Intel workstations can execute MS-DOS applications using a coprocessor board that can be shared across the network. Windowing systems that merge Neworkstation and X Windows 11 from MIT now make windows a network resource like files under NFS. The protocols are in the public domain, and Sun licenses the source code.

Sun also provides graphics independence through PHIGS, the Programmer's Hierarchical Interactive Graphics System. PHIGS runs on Sun-2, -3, and -4 workstations and is supported by the graphics accelerators.

The company is taking a different approach to operating systems, however. Instead of having three operating-system offerings, Sun is integrating AT&T's System V issue 2 with the Berkeley Standard Distribution (BSD) and incorporating the facilities of both into its new SunOS 4.0. Sun and AT&T are working together to define a new integrated operating system that combines the best of both with the intent to establish that operating system as a new standard. This action, in part, led Apollo and others to

form OSF, as they were concerned about their lack of input as well as the effect of possible delays in getting access to the new operating system.

Silicon Graphics

Silicon Graphics, Inc., formed in 1984, has its own approach to the workstation market. SGI is totally committed to three-dimensional graphics in real time and has delivered expensive (\$50,000 and up) workstations for three-dimensional work. SGI uses the best current technology and concentrates on adding its expertise at the graphical interface. In the fall of 1988, SGI announced a "low-cost" (under \$20,000) three-dimensional workstation, the Personal Iris (see photo 3). SGI's products range upward to the 4D/240, which has four parallel processors, each operating at 20 MIPS and 4 MFLOPS. Amazingly, the high-end unit remains under \$100,000.

The Personal Iris is a dynamic three-dimensional graphics workstation designed for personal use. The product emphasis from SGI is "three-dimensional graphics in color." As a result, all products from SGI include color graphics with a graphics processor as standard. When you compare the prices of other workstations with equivalent capabilities, the apparent high cost of the Personal Iris becomes the lowest-cost system for the capabilities provided.

The standard Personal Iris 4D/20 comes with a color graphics board of 1280- by 1024-pixel resolution with 8 color bit planes and 4 administration planes standard, expandable to 24 color bit planes, 8 administration planes, and a 24-bit z-buffer. The expanded model uses 56 bits per pixel, which contributes to the video RAM shortage. The graphics processor can render 4500 to 15,000 polygons per second and produce plain, antialiased, or depth-cued three-dimensional vectors.

The standard processor is no slouch, either. The CPU is a 12.5-MHz MIPS Computer R2000A RISC microprocessor with separate data and instruction caches and is rated at 10 MIPS integer performance. The optional floating-point processor provides 0.9 MFLOPS. Standard memory is 8 megabytes, expandable to 16 megabytes. Ethernet and TCP/IP are standard, as are two serial ports, a Centronics port, a small-computer-system-interface port, audio ports, and a VME slot. Note that a disk drive is not included in the base machine. The entire package will fit under your desk.

Operating-system software called IRIX is based on the Unix System V R3



Photo 3: The SGI Personal Iris, a 10-MIPS workstation for \$16,000.

version with 4.3 BSD features and enhancements for real-time graphics. It is compatible at the binary-code level across the entire 4D workstation line. Standard software includes the SGI environment manager, graphics library, windowing system (Newkstation, GL windows, and X Windows), and diagnostic software. Optional software includes five communications options and 10 productivity software packages for the programmer, including PC-DOS emulation and PHIGS.

Real applications show three-dimensional motion on realistic wire-frame or shaded models. Even a complex fighter model with thousands of line segments moves smoothly with shading, color, and variable illumination. This performance results from separating the physical computing in the main processor from graphical computations, which are done in the graphics processor. You can move and rotate the displayed image without requiring the main processor to do any computing.

The graphics system is, in fact, four processor subsystems dedicated to graphics functions. The four independent subsystems are the host interface (to a 40-megabyte-per-second graphics bus), a geometry engine, a raster subsystem, and a display subsystem. The geometry engine is a microcoded processor capable of 20 MFLOPS. It performs rotation, scaling, and transformation, and separately transforms surface normals. Then it clips vertex coordinates to a 6-plane bounding box and does the first stage of scan conversion. This information is passed to the raster engine, which is almost as complex, and from there to the display controller. There is actually more processor power in the graphics processor than there is in most basic workstations.

This system doesn't have just windows and pop-up menus—the menus open in smooth three-dimensional motion. Push a three-dimensional button, and it rotates and expands, exposing a new set of buttons at each level until you execute an application. There is, of course, a version of Flight Simulator that must be experienced to be appreciated. Motion is smooth, and the landscape is not just a bunch of lines.

NeXT

Next, and last in this case, is the new entry from NeXT. This is the long-awaited workstation for the education market from Steve Jobs. The NeXT workstation, sometimes called the cube, breaks ground in areas ranging from packaging

to optical storage. What has excited much interest is the price/performance, \$6500 for a 25-MHz 68030 and 68882 combination with a high-speed digital-signal processor thrown in for good measure (see photo 4).

There are a number of significant developments here in addition to the price. First, the packaging reaches new levels of compactness, being a 1-foot cube with four slots, and the whole computer fits in only one slot. Second, it has a standard optical disk; it's not just a WORM (write once, read many times) drive but has full read and write capability, with good performance specifications for an optical disk.

Rounding out the hardware is 8 megabytes of memory, 12-channel direct memory access, and a 17-inch monochrome display with integral stereo, microphone, and mouse and keyboard connections. All in all, it's the simplest physical arrangement of hardware for its power.

Software technology was not left behind, either. Unix serves as the operating system, based on the Mach kernel developed at Carnegie-Mellon University. Mach is based on Unix BSD 4.3 but has enhancements in the areas of shared memory, interprocess communications, and potential multiprocessing. Networking is supported by the standard Ethernet and TCP/IP, with NFS from Sun Microsystems.

NeXT has added a graphical window-

ing interface called Workspace Manager to hide the raw Unix prompt. Windows and menus float in the workspace of the screen, and icons become transparent when they overlay other icons, which keeps everything visible. The windowing mechanism is based on Display PostScript.

Development also has its share of new tools. The NeXT system includes an object-oriented preprocessor called Objective-C for the ANSI C compiler. Objective-C supports objects as groups of C procedures, and several libraries of ready-to-use objects, called kits, are provided. Kits are included for music and sound as well as for more prosaic objects. Also provided is something called Interface Builder, which supports the interactive design of user interfaces.

Several applications are bundled with the cube, including a word processor, a mail interface with voice-mail attachments, a searching program called Find, and the usual programmer tools. Beyond these are a group of educational tools, including a Webster's dictionary and thesaurus, Mathematica, *The Oxford Dictionary of Quotations*, and the complete works of Shakespeare. (Full details on the NeXT cube can be found in "The NeXT Computer" in the November 1988 BYTE.)

How does the cube stack up against the other workstations? On basic system specifications, it is more than a match for

continued



Photo 4: The NeXT computer, a 4-MIPS workstation for \$6500.

Companies Mentioned

Apollo Computer, Inc.
330 Billerica Rd.
Chelmsford, MA 01824
(508) 256-6600
Inquiry 983.

NeXT, Inc.
3475 Deer Creek Rd.
Palo Alto, CA 94304
(415) 424-0200
Inquiry 984.

Silicon Graphics, Inc.
2011 North Shoreline Blvd.
Mountain View, CA 94039
(415) 960-1980
Inquiry 985.

Sun Microsystems, Inc.
2550 Garcia Ave.
Mountain View, CA 94043
(415) 960-1330
Inquiry 986.

the typical workstation. But there are a couple of areas that may dampen the enthusiasm of those who want to do real work. First, there is the issue of distribution: It is currently available only to universities. Second, production and software won't be "ramped up" until the second quarter of this year. Third, no applications outside the bundled ones exist, although that should change within the next year. Fourth, current systems don't have a color display.

Where will the NeXT cube succeed? This innovative workstation is among the first of a new breed of "personal workstations" that will filter down into universities, small businesses, and, eventually, homes. It's clear by Jobs's example that current technology can give us a lot more than the personal computer delivers today. It's safe to say that the cube represents a 10-year advance in technology over the IBM PC and should come into its own in the 1990s. But, in my opinion, this year is not NeXT's year.

At Least Today, It's Possible

How does a standard workstation compare with one built on a personal com-

puter? A few years ago, the answer would have been easy—there was no comparison. Today, the answer is more difficult, as the differences are blurred by technological and software advances. A few years hence, the question will no longer be asked. We will simply have a continuum of microprocessor-based computers.

Today, depending on where you start and how much you spend, you can turn your personal computer into a workstation. At some point, expanding a system to its upper limits is actually more expensive than buying one that's built for the task, but you can do it. Adding software on an incremental basis is also usually more expensive than getting it bundled, but again, you can do it. If you have the option and the funds, buying a workstation has its benefits. But building your own on a personal computer base is also a valid option. At least today, it's possible. ■

Bill Nicholls has a B.S. in physics from Notre Dame University and is the owner of BGW Systems (Puyallup, Washington). He can be reached on BIX as "billn."

Outline: The infinite font-cartridge.

Imagine: You have a font-cartridge for your laserprinter: You need more fonts. You can tell this cartridge to do it and use them immediately in your textprocessor.

Large fonts, small fonts, decorative fonts, shadow fonts...

You want to change something? Just tell your font-cartridge. The font change is made in the font selection menu automatically.

You want a new cartridge? Save the old and select the fonts for a new one.

As many times as you want. An infinite number of soft-cartridges. An infinite number of fonts.

THAT'S OUTLINE.

 s.a.x. software

Roonstr. 32 • D7500 Karlsruhe • Tel. 01049/721/814078

Outline supports all HP and compatible laserprinters.
Outline supports MS Word*, WordPerfect*, Windows* (PageMaker*, Excel...)
* registered trademark

Please contact in USA:
Digital Type Systems Ltd.
38 Profile Circle - Nashua NH 03063
Tel. (603) 880-7541



Worth the RISC

*RISC technology is here, it's usable,
and it's low-cost now*

Trevor Marshall and Jane Morrill Tazelaar

If there are to be any major improvements in workstation technology in 1989, they're likely to come from the reduced-instruction-set-computer arena. RISC chips will impact every area: embedded control, graphics, and mathematical calculations. Which areas they'll end up dominating really depends on how quickly the complex-instruction-set-computer designers react to innovative RISC architectures and incorporate those features that really work well into upcoming CISC chips.

What Is RISC?

RISC refers to the concept of a CPU that executes at least one instruction per clock cycle. With a CISC CPU like the 68020, it can take several clock cycles to execute an instruction. The RISC chips, however, execute most of their instructions in one cycle and make further performance gains with a technique called *pipelining*, which uses multiple execution units. The chip actually executes many instructions at the same time.

Some RISC chips, such as the Motorola 88100 and the Advanced Micro Devices (AMD) 29000, execute as many as



five instructions at once, depending on the nature of the instructions. This allows the accesses to the I/O devices, the RAM, main memory, the disk, and the operator to be scheduled so that the CPU's execution unit can continue doing something useful even when the bus interface is performing external accesses. Although the advanced CISC CPUs also use a form of pipelining, their complex

instruction set makes it more difficult for them to achieve the same performance advantage.

Executing at least one instruction per clock cycle is the single thing that most characterizes the RISC chips. Indeed, it's one of the things that sets the Intel 80960 apart from the others: Not all of its instructions are one-word instructions, and thus they don't all execute in one cycle. There are some other characteristics that define RISC as well. But before discussing them, it will be helpful to look at the chips themselves.

The RISC Chips

The Clipper, developed by Fairchild, is probably the most mature RISC chip. Fairchild was bought by National Semiconductor, which sold the Clipper Division to Intergraph, a workstation manufacturer. Most designers don't regard the Clipper as an available family, but in fact you can buy Clipper chip sets from Intergraph.

Then there's Motorola: The 88000 is a three-chip set that consists of the 88100 CPU and two or more cache/memory management units, 88200s. The 88100 has built-in floating-point capabilities.

continued

Next comes AMD's CPU, the 29000; its associated floating-point chip is the 29027. Cache units are expected but are not yet part of the equation, so at this point the AMD chip set consists of the 29000 and the 29027 and is targeted at low-cost RISC applications.

MIPS Computer Systems offers the R3000 CPU and the R3010 floating-point accelerator. The MIPS family is best characterized by its (relatively) mature software base and close ties with a

cache-memory architecture. Indeed, it's very hard to connect the R3000 to any memory system that does not use caching. This family of chips is thus restricted to more complex (and expensive) workstation applications.

In the Sun Microsystems' SPARC (scalable processor architecture) family, the first chip came from Fujitsu. Sun is currently shipping this CPU chip in the Sun 4 workstations, using the Weitek floating-point chip set to augment its

arithmetic capabilities. The SPARC family is now becoming better known, and promising products have come on-line in 1988. Cypress Semiconductor has a SPARC implementation called the 7C600 family, which consists of the 7C601 CPU integer unit, the 7C603 memory management unit, the 7C608 floating-point controller, the 74ACT8847 floating-point unit (FPU) (actually made by Texas Instruments), and the 7C181 cache-tag RAM. Cypress is the second source that Sun licensed after Fujitsu had implemented the first member of the SPARC family. At this time, most of the Cypress SPARC chips are only just starting to become available.

The actual SPARC family, all those who have licensed the technology, includes TI, Cypress, BIT (Bipolar Integrated Technology), Fujitsu, and LSI Logic. Chips are actually on the shelf from Fujitsu and Cypress, and TI has its FPU out.

SPARC is probably the most difficult to comprehend of the whole lot. It's the only RISC chip currently being shipped by more than one manufacturer (although MIPS has now announced multiple sources for its parts). After the 80386, whose price was driven very high because you could only get it from Intel, people became wary of sole-source CPUs. When Sun brought out its SPARC chip in 1987, the company made it known that there would be multiple sources for the chip.

The multiple-source availability question really isn't much of a problem with RISC chips because there are so many of them and they are competitively priced. In fact, prices are already very inexpensive. There are 17 MIPS RISC machines currently available, and their cost, at least in large quantities, is around \$10 per MIPS. That's a lot cheaper than an 80386.

IBM also has a RISC chip, but at this point it doesn't have the level of performance that the others are starting to show. In addition, it's not being marketed, at least not aggressively, as a chip set—it comes only in the IBM RT system—so we have little information about it to pass on to you.

The Intel 80960 chip's instructions are not fixed-length, but they are put on 32-bit boundaries. Such things as its optional displacements make the 80960 somewhat different from a typical RISC chip. It is a great chip for embedded control, which is what it's designed to do, but it doesn't yet have the level of performance that the other RISC chips have. Intel and AMD are both pushing their

the Telcor modem "simply ate up our data."

38.4K
bps



John H. Humphrey and Gary S. Smock
High Speed Modems
June 1988, Byte Magazine

you find that hard to believe, prove it to yourself. Order a pair at \$1195 apiece and try them for thirty days. High speed file transfer software for your PC-AT is included.

Call us toll free in the U.S. at 1-800-826-2938. Elsewhere call 1-508-653-3995. VISA and Mastercard accepted. Also available through local distributors.

telcor
TELCOR
SYSTEMS
CORPORATION

*the world's fastest
dial modems*

Our patented Model 2496 data compressing modem was the only 2400 bps unit included in this evaluation of 9600 bps dial modems. And it was judged the surprise of the lot!

Just imagine what our 9600 bps modem can do . . . dial data throughput up to 38,400 bps. What's more, the Telcor Model 2938 also talks to 300, 1200 and 2400 bps modems and fully supports MNP Levels 2-6.

The Telcor Model 2938 outperforms any other dial modem in the world. If

chips at the lower-cost end of the market. They are each trying to say, "With my chip, you can design a system that is as fast as a workstation but at a fraction of the price." By and large they're correct, and they're keeping prices down by using innovative memory technologies.

Banking on Registers

Another characteristic of RISC CPUs is a lot of registers and very fast access to the register bank. Keeping the signals running around on the same silicon chip is much faster than going off the chip to main memory, disk, or the keyboard. This helps to enhance speed.

With chips like the Motorola 88000, AMD 29000, and MIPS R3000, you can both read and write to the register set in one cycle, so its memory is extremely fast. And since you have a large register set, you can do a lot of calculations without having to go out to main memory. SPARC implementations typically have 128 registers; the AMD 29000 has 192. The Clipper has 40—32 integer 32-bit registers and 8 64-bit floating-point registers. The Motorola 88100 CPU has only 32 registers, but 32 is still a reasonable number. The MIPS architecture has 32 registers. The Intel set has a pseudo-register, not true registers, but it's also 32 words deep.

The larger the register bank, the more calculations you can force to run in the high-speed internal registers—but you incur a penalty when you do multitasking. For instance, if you have a single task that uses 128 registers, and you switch to the next task (which also needs all the registers), you have to save them all to memory. Then, when you switch back to the first task, you have to restore them all. Thus the more registers the chip has, the higher the overhead it incurs when it needs to save and restore them.

AMD, Motorola, SPARC, and MIPS all have special features in their architectures to allow you to store and read back registers as fast as is practical. For instance, if you're storing to 128 sequential locations, you can do it much faster than if you stored individual registers one at a time. Both SPARC and AMD provide hardware support for doing multiple stores; a protocol defined in the wires that connect up to the RAM interface, to the real world, allows these high-speed bursts of register saving and restoring operations. But it's still an overhead you must take into account. That's the penalty for using a lot of registers, but the performance improvement tends to make up for it.

Table 1: The RISC chips. The VAX MIPS estimate is usually derived by dividing the Dhrystone rating by 2000. As you can see, some manufacturers are conservative in their MIPS estimates while others are overly optimistic. (These numbers are from the manufacturers and are not the result of independent testing. Where MIPS numbers were not available, they have been calculated.)

	VAX MIPS	Cache support	Architecture	Number of registers	Approximate Dhrystones/second
Motorola 88000	20	Yes	Harvard	32	46,000 at 25 MHz
MIPS R3000	20	Yes	von Neumann	32	42,300
AMD 29000	17	No	Harvard	192	42,000
Cypress SPARC	20	Yes	von Neumann	128	42,000 at 33 MHz
Intergraph Clipper	17	Yes	von Neumann	40	35,000
Sun (Fujitsu) SPARC	9.5	Yes	von Neumann	128	19,100 at 16 MHz
Intel 80960	7.5-10	No	von Neumann	32	13,000

This penalty doesn't come into play with CISC chips, which typically have only a few registers. For example, typical compilers used with a 68020-based machine use a maximum of 8 general-purpose registers and 4 floating-point registers—the rest are scratch registers. In current CISC technology, you don't gain much speed by using registers, so most compilers don't overuse them.

Compilers for RISC chips, however, use lots of registers to get the best performance, the highest number of Dhrystones per second, and so on. For instance, the MetaWare compiler for the AMD 29000 uses all 192 registers. And it has routines called *spill* and *fill—spill* when the registers overflow to send them out to RAM and *fill* when they underflow to pull them back in.

This huge register stack acts as a window into RAM. Using it is a very efficient way of writing compilers, and most RISC compilers use it. The Sun compiler, however, has something different: a register-windowing scheme. It tends to have the same effect; it's just a different way of describing things. With the register-window concept, you must define a fixed number of variables that you will pass between procedures. For instance, if you only need to pass three registers between procedures and you switch your level of register windowing, you're going to waste five of the eight defined registers. None of the other chips has this windowing scheme. The inefficiency it causes seems to be relatively minor, probably only the last 10 percent of difference in speed.

Cache in the Chips

A computer system today is designed with a CPU and a large (slow) main

memory; in the middle, between the two, is cache memory. Cache is a high-speed memory that buffers between the high speed of the CPU and the low speed of main memory. All the conventional workstations use cache memory.

With RISC machines, cache performance becomes critical. You can have a CPU that's running three, four, or five times faster than a CISC chip, but you still have the same-speed memory, the same DRAMs. Therefore, the function of the cache is to buffer. How you make the operation of the CPU more efficient with the slower main memory becomes of paramount importance.

There are ways of designing unique memory systems that are structured differently from the conventional CPU, cache, and memory setup. You can connect the CPU directly to specially configured main memory. While you won't achieve quite the same level of performance that you would with a cache, you're talking about only a 10 percent to 20 percent difference (see the article "Real-World RISCs" in the May 1988 BYTE). Yet your cost difference will be significant. The cache is becoming one of the most expensive items on a workstation, be it CISC or RISC.

Both the Sun 4 and the MIPS machine have fairly good caches, typically 128K bytes of cache RAM each. That's high-speed static RAM, and it tends to be much more expensive than several megabytes of DRAM.

The MIPS people stress close integration with the cache. In fact, their whole system is designed around it. Basically, they will sell you an agreement whereby they tell you how to design the cache. They give you all the details, down to

continued

which chip you connect to which chip. They probably have the most advanced system of any RISC cache to date. The MIPS chip is very closely integrated with its high-performance cache design.

The Sun 4 uses an expansion of the Sun 3 cache technology. Motorola has cache memory management units (MMUs), the 88200s, which are very expensive (several times the cost of the CPU) but allow you to connect low-speed memory and still get tolerable performance. Each MMU contains 16K bytes of high-speed cache memory. They let designers look at the RISC CPU as a "black box" and not have to worry about high-speed memory designs.

For example, if you're designing a system around the AMD 29000, you have to look at all the timing diagrams. You have to understand what's happening in the internal pipelines. You have to know when the system's going to be asking for another instruction and when it's going to be accessing data. Once you understand these things, you can mold the memory to what the CPU does.

With Motorola's three-chip set, the cache memory buffers all that. All you really have to understand is how to connect to a cache memory. You don't have to be concerned about what the CPU is doing. The cache memory handles that interface for you, so the "black box" approach is an easier level of design. The Clipper also allows you to design at this level.

Motorola and Intergraph both sell integrated cache chips, which have the RAM as well as the control circuitry inside; they're all you need to implement a cache. It's not as good as the MIPS cache—and it's certainly not as large—but it's low-cost and convenient.

Both Intel and AMD have concentrated on designing interfaces for their chips so you can couple them to low-cost memory, producing a low-cost, high-performance system. To give you some idea of the performance levels you can get, it's possible on low-cost \$3000 to \$4000 hardware to achieve 30,000 Dhrystones per second. Intel isn't even talking about cache. AMD is working on a cache unit—but it's very effective when connected directly to RAM. And Fujitsu uses the Sun cache technology.

Cypress has designed its family around a cached-memory architecture. The company provides two cache-support chips to simplify high-speed cache design, both the RAM itself and the special cache-tag RAM. You get schematics on how to connect them into a system. Cypress is also emphasizing the cache

and has made no attempt yet to allow its SPARC chip to be effectively connected directly to main memory.

Comparing the Chips

The first major comparison point for these chips is whether they stress cache or noncache technologies (see table 1). Any of them can be used in either mode, but with varying degrees of difficulty. AMD and Intel are pushing noncache systems; all the other manufacturers are pushing cache systems. That's the first distinction, cache or noncache.

The next distinction is whether the chips have Harvard or von Neumann architecture. A von Neumann architecture has one external 32-bit bus that is used for both data and instructions. A Harvard architecture has two separate 32-bit buses, one for bringing in the instructions and one for the data. A Harvard architecture allows you to bring data and instructions to the chip at the same time. Of the RISC chips, the Motorola 88000 and the AMD 29000 use the external Harvard architecture.

So the capability is there, in theory at least, to double your memory-interface speed. It doesn't work that way, however; you probably multiply it only by one and a half. Nevertheless, the Harvard architecture significantly raises the interface speed without significantly changing the interface cost. This architecture allows you to customize the type of memory you connect, since it has to work well only with data references or with instruction references, not both.

One similarity shared by the families is that they're all vying for the same marketplace, and when all is said and done, the CPU chips are similar in price. In essence, the choice of a CPU won't, by itself, affect the final cost of a workstation very much, because RAM is now becoming the biggest part of the cost. A workstation today will have 8 megabytes or more of RAM, and all the CPU chips are relatively inexpensive when compared to the cost of 8 megabytes of RAM. Thus, the choice of a CPU is usually not based on raw chip cost anymore. Some workstations still have expensive FPUs, but since they're all competing for the same piece of the pie, that too must change.

One way to compare RISC chips is to look at which ones have been around the longest and which are just emerging. For example, the Clipper is the most mature while the Motorola 88000 doesn't really exist yet. There are a few chips in the hands of developers—and they work—but they're not shipping in quantity yet.

The AMD family has been shipping

for nearly a year. The MIPS family has been around for quite a while now, too—at least the R2000 has (for maybe 2 years), and the R3000 is derived from that. A few minor changes were made, but the R3000 has essentially the same genealogy and longevity as the R2000. The MIPS chip is the most mature RISC chip available except for the Clipper. It's even more mature than Sun's SPARC.

Sun's SPARC technology is about a year and a half old, so it's fairly mature, too. One way to judge the maturity of a chip is by the languages available to support it (e.g., C, FORTRAN, and Ada). This is particularly true for RISC. You don't want to be developing code on tools that are themselves still in beta test. Sun and MIPS have lots of software tools in place; AMD has some; and Motorola has very few. The Intel 80960 is relatively new also; it has only recently started to ship, but it *does* exist and it *is* shipping.

The venerable Clipper isn't always remembered because it's not from one of the major semiconductor houses—Sun's chips are from Fujitsu, for instance, and Cypress is quite big in CMOS. However, the Clipper performs reasonably, certainly at about the same level as the SPARC. It consists of a CPU and two cache units mounted on a circuit board. It's marketed with a "black box" concept like Motorola's; Intergraph tells you how to connect to the circuit board and not to worry about what's on the board—it'll take care of itself. And it does.

A Benefit Performance

We used the Dhrystone benchmark to compare the various RISC chips. The Dhrystone measures a chip's ability to handle integer operations, particularly string operations such as those that occur in compiling and the searching of databases.

The AMD, MIPS, and Motorola chips all run at about 42,000 Dhrystones per second, with peak performance up about 46,000. For comparison, the 68020 CISC chip rates about 5500 Dhrystones, and the 68030 has tested as high as 7000 Dhrystones. The 80386 can do 9000 Dhrystones but has an advantage for the Dhrystone test over the 680x0 family due to special string-manipulation instructions. You can see that the differences among RISC chips are much smaller than the gap between CISC and RISC.

The Sun 4 SPARC (which is a Fujitsu SPARC in the Sun 4) comes in at around 19,000 Dhrystones, so it's not quite up to the general-architecture RISC chips yet. That may change. The new SPARC implementation from Cypress is faster, and

there are some gallium-arsenide SPARC implementations coming from a company called Prisma in Colorado Springs, Colorado. A group at McDonnell Douglas is also working on such a chip, and so is BIT.

The Cypress SPARC chip is said to run at about 42,000 Dhrystones at 33 MHz. The Clipper comes in at 35,000, and Intel's 80960 currently has the lowest performance rating, around 13,000 Dhrystones. The top three performers are MIPS, Motorola, and AMD. Then comes Cypress and the Clipper. The next best performer is Sun, with Intel currently bringing up the rear. Intel promises more performance next year.

Performance, however, is relative to your application. The Intel chips are aimed at embedded control, such as laser printers. You want a very fast CPU to run your laser printer, but you don't really care whether that same chip will run spreadsheets and databases. Intel is aiming its RISC family at that market so a high Dhrystone performance rating is not crucial. However, all the chip makers, certainly both Motorola and AMD, are also targeting that market, because it's a big one.

The workstation marketplace accounts for only a small fraction of the total number of CPU chips sold. But all the manufacturers are trying to have a presence there because it allows them to project their chips toward the embedded-control designers.

A Graphic Demonstration

The RISC chips will definitely have an impact on graphics. They offer an alternative to the special-purpose graphics engines that companies like Silicon Graphics have developed. They are computing power, pure and simple, regardless of the application. Their designers have put their entire computing knowledge into creating ultrahigh-speed CPUs. What they have come up with are general-purpose CPUs that in many cases exceed the speed of special-purpose CPUs even within the special-purpose application. For example, AMD has a graphics chip, called the quad-pixel data-flow manager (QPDM), which was specifically designed and optimized to do graphics manipulations. However, AMD has found that the 29000 RISC chip can outperform the QPDM in most graphics operations. These RISC chips are extremely high-speed devices and will surely have an impact on graphics at all price levels.

AMD is talking about pricing its RISC chips at \$99 next year. Given that sort of

Companies Mentioned

Advanced Micro Devices
901 Thompson Place
P.O. Box 3453
Sunnyvale, CA 94088
(408) 732-2400
Inquiry 1058.

Cypress Semiconductor
3901 North First St.
San Jose, CA 95134
(408) 943-2600
Inquiry 1059.

Intel Corp.
3065 Bowers Ave.
Santa Clara, CA 95051
(408) 765-8080
Inquiry 1060.

Intergraph
2400 Geng Rd.
Palo Alto, CA 94303
(415) 494-8800
Inquiry 1061.

MIPS Computer Systems
928 Arques Ave.
Sunnyvale, CA 94086
(408) 720-1700
Inquiry 1064.

Motorola
6501 William Cannon Dr. W
Austin, TX 78735
(800) 441-2447
Inquiry 1062.

Sun Microsystems, Inc.
2550 Garcia Ave.
Mountain View, CA 94043
(415) 960-1300
Inquiry 1063.

price, the chips could even start coming out in low-end personal computers, giving them a graphics capability they've never had before.

A Definite Impact

If you're sitting back waiting for a winner to appear in the RISC sweepstakes while you can buy a chip that will do the job you want to do right now, it's probably not worth waiting any longer. All RISC technology is scalable. There's going to be leap frogging—a new chip will come out in March, and another in July,

that sort of thing. But the quantum leap in RISC technology has already occurred. All the top chips—the MIPS, the AMD, the Motorola, and even the Clipper—are already achieving the performance levels (within 30 percent or so) that they will have by the end of this year. RISC technology is here; it's usable; and it's low-cost now.

Furthermore, a workstation's performance is primarily dependent on the designer, not on the chip. Take, for example, the MIPS family of machines. If you compare the workstation from Silicon Graphics (which uses a MIPS CPU) and the workstation from MIPS Computer Systems (which uses a MIPS CPU), you'll find that the machine from MIPS has a much higher performance than the one from Silicon Graphics. Why? Because MIPS uses more effective caches; it's a more expensive machine; it has been designed from the ground up to be a high-performance computer. The Silicon Graphics machine has been designed to be a high-performance, low-cost graphics machine. Thus, some of the computational ability of the MIPS CPU has been traded off for those graphics features.

If you use the MIPS computer (with 64K bytes of static RAM cache) and the low-end Silicon Graphics machine (with a much simpler architecture) to run a benchmark that has a lot of data manipulation, like the LINPACK algorithm, you'll find as much as a 50 percent speed difference. This can be very significant, and it's probably the best example we can give of how critical the design of the system is. So if you're buying a workstation, you should evaluate what's being offered as the workstation, run your code on it, and work out what you want to buy based on what the system will do with *your* code. The underlying chip is far less important.

The levels of RISC performance are so high that applications that weren't practical on workstations in the recent past will be in the near future. Applications, such as three-dimensional rendering, that took impossibly long times to compute on last year's workstations can now complete in one-tenth the time. Obviously, RISC technology is going to have a profound effect on the way we use computers. ■

Trevor Marshall is chief engineer at Yarc Systems Corp. in Thousand Oaks, California. Jane Morrill Tazelaar is BYTE's senior technical editor, in depth. They can be reached on BIX as "tmarshall" and "janetaz," respectively.

Compuclassics

SOFTWARE

ALDUS	
Pagemaker 3.0	519.00
AMERICAN SMALL BUSINESS	
Design Cad	159.00
Design Cad 3D	159.00
ASHTON TATE	
Multimate II	279.00
Dbase IVs	489.00
Dbase IV Developers Edition	849.00
Rapidfile	195.00
Framework II	429.00
Chartmaster	229.00
Master Graphics	299.00
ASK SAM SYSTEM	
Ask Sam	235.00
AUTODESK	
Autosketch Enhanced	65.00
BANNER BLUE	
Org Plus	59.00
BLAISE COMPUTING	
Turbo Power Tools Plus	92.00
Turbo Async Manager Plus	125.00
C Tools Plus	92.00
C Async Manager	125.00
BLOC DEVELOPMENT	
Formtool W/Greatest Hits	59.00
BORLAND	
Sprint	129.00
Sidekick Plus	135.00
Eureka	109.00
Quattro	165.00
Turbo Graphix	69.00
Reflex	99.00
Superkey	69.00
Turbo Prolog	99.00
Turbo Basic	62.00
Turbo C	99.00
Paradox V 2.0	479.00
Turbo Pascal 5.0	99.00
Turbo Tutor 4.0	49.00
BOURBAKI	
1 Dir Plus 1.05	55.00
BRIDGEWAY PUBLISHING	
Faasttrax	39.00
BRODERBUND	
Print Shop	35.00
Memory Mate	45.00
BUTTONWARE	
PC File	45.00
CENTRAL POINT	
Copy II PC	25.00
Copy II PC Option Brd Dlx	109.00
PC Tools Deluxe	39.00
CHRONOS SOFTWARE	
Who What When	149.00
CHIPSOFT	
Turbo Tax	49.00
Turbo Tax State	29.00
Turbo Tax Professional	169.00
Turbo Tax Professional State	115.00
CLARIS	
Nutshell Plus	219.00
COMPUTER ASSOCIATES	
Supercalc V	319.00
Superproject Expert	445.00
ACCPAC BPI	275.00
Silverado	99.00
CONCENTRIC DATA SYSTEMS	
R & R Relational Report	109.00
CORE INTERNATIONAL	
Corefast	89.00
DAC	
Easy Accounting 3.0	59.00
Easy Payroll 3.0	59.00
Bonus Pack 3.0	115.00
DATASTORM	
Procomm Plus	52.00
DBFAST	
Dblast	62.00
DIGITAL RESEARCH	
Gem Desktop	32.00
Gem Draw Plus	179.00
Gem 1st Word Plus	119.00
Presentation Team	285.00
Desktop Publisher	179.00
DIGITALK	
Smalltalk V	75.00
Smalltalk V 286	145.00
EXECUTIVE SYSTEMS	
X Tree	37.00
X Tree Pro	69.00

FIFTH GENERATION	
Fastback	92.00
Fastback Plus	109.00
FORMWORX	
Formworx w/Fill & File	89.00
FOX SOFTWARE	
Foxbase Plus	199.00
Foxbase Multi-user	299.00
Foxbase Runtime Unlimited	265.00
FUNK SOFTWARE	
Always	95.00
Sideways	40.00
GENERIC SOFTWARE	
Generic Cad 3.0	55.00
Dot Plot	27.00
Auto Convert	27.00
Auto Dimension	27.00
3D Solid Modeling/Rendering	179.00
GIBSON TECHNOLOGY + Spinwrite	55.00
GOLDEN BOW	
V Feature Deluxe	125.00
V Cache	45.00
IBM	
Displaywrite IV	299.00
DDS 4.01	119.00
INTUIT	
Quicken	39.00
LASERGO	
Go Script	160.00
Go Script Plus	279.00
LATTICE	
Lattice C Compiler	229.00
LEADING EDGE	
Word Processor W/Spell/Merge	59.00
Word Processor V1.5	89.00
LOTUS DEVELOPMENT	
All Products	CALL
MATHSOFT	
Mathcad 2.0	225.00
MECA	
Managing Your Money 4.0	125.00
MERIDIAN TECHNOLOGY	
Carbon Copy Plus	115.00
MICROGRAFX	
Designer	465.00
MICROLOGIC	
Tornado	59.00
MICROLYTICS	
Goler	42.00
MICROPRO	
Wordstar Professional 5.0	249.00
Wordstar 2000 Plus	239.00
MICRORIM	
Rbase for Dos	475.00
MICROSOFT	
Pageview	35.00
Quick C	67.00
Word	225.00
Quickbasic	67.00
C Compiler	299.00
Fortran Compiler	299.00
Macro Assembler	99.00
Learning DOS	35.00
Flight Simulator	35.00
Excel	309.00
Windows 386	129.00
MICROSTUF	
Crosstalk XVI	99.00
Crosstalk Mark 4	125.00
NANTUCKET	
Clipper	439.00
NEW ENGLAND SOFTWARE	
Graph-In-The-Box	75.00
NORTH EDGE SOFTWARE	
Timeslips III	115.00
PAPERBACK SOFTWARE	
VP Info	65.00
VP Planner	55.00
VP Planner Plus	129.00
PATTON & PATTON	
Flowcharting II Plus	145.00
PAUL MACE	
Mace Utilities	55.00
PERSOFT	
Ize	269.00
PC SUPPORT GROUP	
Lightning	55.00
Lucid 3D V 2.0	89.00
PEACHTREE	
Complete Accounting II	159.00
Complete Accounting w/Data Query	235.00
PERSOFT	
Smartterm 240	209.00
Referee	45.00

PETER NORTON	
Norton Utilities	50.00
Norton Utilities Advanced	79.00
Norton Commander	49.00
PRIME SOLUTIONS	
Disk Technician	59.00
Disk Technician Plus	79.00
QUAD SOFTWARE	
Copywrite w/Zerodisk	CALL
QUARTERDECK	
Desqview 2.2	75.00
REFERENCE SOFTWARE	
Grammatik III	55.00
RIGHTSOFT	
Rightwriter	59.00
SANTA CRUZ OPERATION	
Xenix 286 Operating Sys	469.00
Xenix 286 Development Sys	469.00
Xenix 386 Operating Sys	539.00
Xenix 386 Development Sys	539.00
SCITOR	
Project Scheduler Network 4.0	439.00
SIMON & SCHUSTER	
New World Writer II	99.00
Typing Tutor IV	32.00
SOFTCLONE	
Mirror II	35.00
SOFTLOGIC SOLUTIONS	
Disk Optimizer	42.00
Cubit	42.00
Double DOS	42.00
@ Liberty	115.00
Magic Mirror	59.00
SOFTWARE MASTER	
Flash 5.6	49.00
SOFTWARE PUBLISHING	
PFS First Publisher	79.00
Professional Write	119.00
Professional File	179.00
PFS First Choice	99.00
Harvard Total Project III	449.00
Harvard Graphics	295.00
STORAGE DIMENSIONS	
Speedstor	49.00
SYMANTEC	
Timeline V3	329.00
Grandview	159.00
Note-It-Plus	49.00
SOZ Plus	59.00
Cambridge Spreadsheet Analyst	89.00
TRANSE SYSTEMS	
Masterkey Unlock	109.00
dAnalyst	179.00
TRAVELING SOFTWARE	
Laplink Plus	85.00
UNISON WORLD	
Printmaster Plus	32.00
Art Gallery I & II & III (Each)	19.00
Newsmaster II	55.00
WISEWARE	
Prime Time	65.00
WORD PERFECT CORPORATION	
Word Perfect 5.0	239.00
Word Perfect Network Server	349.00
Word Perfect Network Add-On	75.00
Plan Perfect	195.00
Data Perfect	299.00
Word Perfect Executive	125.00
Word Perfect Library	65.00
WORD TECH	
DBXL Diamond	115.00
Quicksilver Diamond	345.00
XEROX	
Ventura Publisher 2.0	519.00
HARDWARE	
ARRAY TECHNOLOGIES (ATI)	
VIP VGA	249.00
EGAWonder 800	249.00
AST RESEARCH	
Six Pack Plus 384K	269.00
Rampage AT 512K	439.00
Rampage Plus 512K	559.00
AST 525/111 Enhanced	579.00
ATD ZUCKER	
Monographics Short Card	79.00
Memory Expansion 384K	219.00
Modular I/O Bare P/S/Clock	75.00
Clock Board Standalone	42.00
1200 Baud Internal Modem	85.00
CITIZEN	
1200	159.00
MSP 40	349.00
MSP 15E	359.00
MSP 50	445.00

EVEREX	
EV 1800 8MHz AT System	969.00
EV 1800 10MHz AT 0 Wait	1179.00
Evercom II 1200 Modem	75.00
Evercom III 2400 Int Modem	155.00
Magic I/O For AT	59.00
RAM 3000 EMS Expansion	99.00
FIFTH GENERATION	
Logical Connection 256K	469.00
HAYES	
Smartmodem 2400	465.00
Smartmodem 2400B W/Software	465.00
HERCULES	
Hercules Monochrome Plus	189.00
NEWLETT PACKARD	
Laserjet II	1849.00
Fonts/Cartridges for Laserjet II	CALL
INTEL	
Above Board 286 W/512K	429.00
Above Board Plus w/512K	495.00
8087-3 (8 MHz)	109.00
8087-2 (8 MHz)	159.00
80287 (6 MHz)	175.00
80827 (8 MHz)	250.00
80287 (10 MHz)	319.00
Inboard 386 PC or 386 AT	899.00
INTERNATIONAL BATTERY	
AT Replacement Battery	19.50
AST Six Pack Battery	3.50
IRWIN MAGNETICS	
120 XT 20MB Internal	339.00
125 AT 20 MB Internal	339.00
KENSINGTON	
Masterpiece	89.00
Masterpiece Plus	105.00
Masterpiece Remote	115.00
LOGITECH	
Logimouse C7	75.00
Logimouse Hi Rez	99.00
Logimouse C7 + Paintbrush	95.00
Logimouse W/Cad/Paint	125.00
Publisher Mouse	125.00
Scanman	199.00
MICROSOFT	
BUS Mouse W/Paintbrush	109.00
BUS Mouse W/Windows	145.00
Serial Mouse W/Paintbrush	109.00
Serial Mouse W/Windows	145.00
MICRO SPEED	
Fast Trap	95.00
MOUSE SYSTEMS	
PC Mouse BUS Plus	95.00
PC Mouse Serial Plus	95.00
NEC HOME ELECTRONICS	
Multisync II	629.00
ORCHID	
Orchid Pro Designer	299.00
Pro Designer VGA Plus	359.00
PANASONIC	
KX-P10911	209.00
KX-P1595	479.00
KX-P1524	649.00
KX-10921	365.00
PARADISE	
Autoswitch 480	199.00
VGA Plus	295.00
PLUS DEVELOPMENT	
Hardcard 20 MB	569.00
Hardcard 40 MB	709.00
POLAROID	
Polaroid Palette	1499.00
Polaroid Palette Plus	2399.00
PRACTICAL PERIPHERALS	
Practical Modem 1200 Internal	69.00
Practical Modem 1200 SA	109.00
Practical Modem 2400 INT	155.00
Practical Modem 2400 SA	185.00
SAMSUNG	
Amber Monitor	85.00
SEAGATE TECHNOLOGY	
All Products	CALL
SUMMAGRAPHICS	
Summasketch 1201 Plus	389.00
SYSGEN	
Ext 5 1/4" Drive	289.00
TOUCHBASE	
Worldport 2400 Modem	269.00
Worldport 1200 Modem	159.00
TOSHIBA	
T 1000 Laptop	875.00
T 3100-20 Laptop	3415.00
P321 SL Printer	549.00
P341 SL	759.00
P351 SX	1175.00

ADVANTAGES

- We welcome corporate accounts
- Immediate replacement of defective goods.
- Bulk discounts
- Immediate shipment on purchase orders from qualified government institutions

- (schools and universities included)
- No hidden charges.
- No minimum.

TERMS:

All prices are subject to change without notice. We

do not guarantee compatibility. No surcharge for VISA or MasterCard. 2% surcharge American Express. No returns without RA#.

Short shipments must be notified within 48 hours. 15% restocking fee on non-defective goods: \$3.50 C.O.D. charge. Shipping \$4.50 minimum per item, less on bulk orders. (\$8.50 Blue Label.) (Higher for some software or hardware items.)

Call for prices for any software item not included in this price list.

Order desk & technical support open 7 a.m. to 6 p.m. Monday-Friday (PST) 10 a.m. to 2 p.m. Saturday (PST)
P.O. BOX 1588
 6934 Canby St., Suite #109-110
 Reseda, CA 91335
 Telex 292415COMPUR U/Fax 818-705-4885

WE WELCOME INTERNATIONAL ORDERS

How Fast Is Fast?

MIPS? MHz? MFLOPS? The ultimate measurement is probably your own workload.

Bill Kindel

Our generation is obsessed with speed. Whether we're thinking about automobiles or computers, we're sure to ask, "How fast will it go?" With cars, miles per hour provides an unambiguous answer. But with computers, the best answer is, "As fast as it can."

Measuring a computer's performance is not as simple as we'd like. The most popular measures of relative performance are, at best, imprecise; at worst, they can be misleading and meaningless.

I'll discuss some of the pitfalls inherent in assigning performance numbers to computer systems. Once you are familiar with some of the factors that contribute to performance, you should be better prepared to weigh their significance when presented with benchmark and performance test results.

Timing the Instructions

The most common units of performance are usually derived from measuring the time required for the computer's processor to execute some arbitrary set of instructions. Such measurements are expressed as KOPS (thousands of opera-



tions per second), MIPS (millions of instructions per second), or MFLOPS (millions of floating-point operations per second). These measurements are most meaningful when comparing processors from the same family, because the instructions implemented on dissimilar processors can vary dramatically.

As an example of where instruction timings can be misleading, consider how

three different processors might move a character string from one place in memory to another:

- Processor A has a fairly typical instruction set, which includes load/store operations for 1 or more bytes at a time and a broad selection of addressing forms. The data movement would be done by repetitively loading chunks of data from source memory to a register and storing them from the register to the destination memory. At the end of the loop is a completion test, which becomes part of the timing.

- Processor B implements a richer instruction set, including special instructions for character-string manipulation. In such a case, a single instruction can be executed to move the string from the

source memory location to the destination without needing to use any of the general registers. While the single instruction appears to be quite long-running compared with individual load and store instructions, it should be able to move the character string considerably faster. A 5-to-1 speed advantage is not uncommon.

continued

The CPU Effect

At the center of the system is an oscillator, the *clock*, which is often crystal-controlled. Some personal computers use a single clock for everything from the processor to the display. Workstations and larger systems may have separate clocks for each major subsystem. The clock frequency can be halved, quartered, and further divided to provide the correct frequencies to the various chips. On the other hand, the same result can be achieved by multiplying the power-line frequency to raise it (with less precision) to the desired frequencies.

The CPU contains several logical subunits. These can be implemented as discrete components or integrated into a single chip. Some number of registers

are used to hold pointers to data in memory or intermediate computational results and other processor-specific information. A specialized subunit decodes the operation code. The address translation occurs in another subunit, which provides the physical addresses of memory to be fetched or stored. One or more *operation* subunits actually perform the instruction, sometimes splitting off instructions based on the type of data on which they operate.

Machine instructions are executed in several steps, varying by the implementation and the instruction being executed (see figure A). The first step is to read the operation code from memory. This is then decoded, and the number and type of arguments are determined.

Arguments almost always follow the operation in the instruction stream. Each argument is read from memory and interpreted in two more steps. In most cases, arguments contain the addresses of the data on which the instruction operates. Sometimes "immediate data" is provided, which can be used without further interpretation. In other cases, the argument points to a location in memory that holds the address of the actual data. Then it becomes necessary to do yet another read from memory. Data addresses are often the combination of the address or offset given in the argument and the contents of one or more processor registers. All these calculations occur before the actual operation can take place.

After calculating the data addresses, any input values must be read from memory (and processor registers) into the operation unit. Finally, the actual operation is performed. Any registers or memory locations that are changed are updated from the operation unit. Instructions that loop through memory may read and write many locations in sequence.

Several techniques are used to speed up processing. The first is cache memory, which can greatly reduce the time the processor spends waiting for memory accesses. Various strategies can be used, but all depend on the fact that a high percentage of memory accesses are to a relatively small number of different addresses.

The cache, which is logically adjacent to the processor's operation unit, keeps copies of the current values of the most recently accessed memory locations. When memory is read, the cache is searched first. Only if the cache does not contain the address's data is an actual memory read requested. While a read from memory requires several clock cycles to complete, cache "hits" are nearly immediate.

A second significant technique is called *pipelining*. Because different parts of the processor are actually used

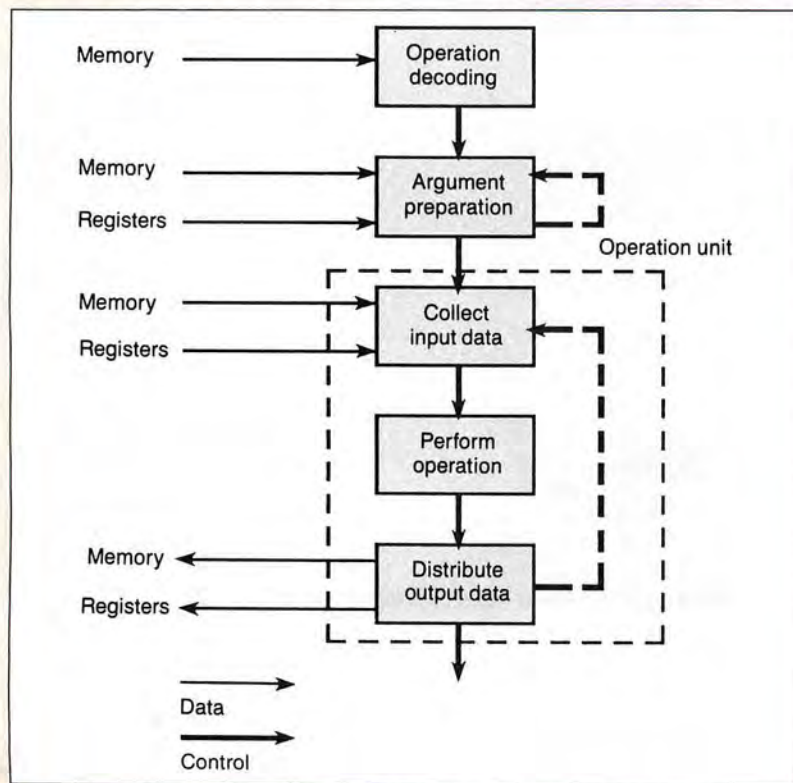

Figure A: Simplified processor flow. These several steps of machine-instruction execution may vary depending on your machine and the instruction.

• Processor C is a RISC (reduced instruction set computer) version. To gain speed, RISC processors simplify both their instruction sets and their addressing modes. This speeds up both the instruction-decoding and argument-preparation

phases of each instruction. RISC processors also gain speed by using register-to-register operations rather than operations that access memory. As an aid, RISC processors are sometimes provided with more computational registers than non-

RISC processors have.

In the wide-open world of MIPS comparisons, such processor mismatches are common. The search for a representative sample of instructions to time often set-

for the execution of the various steps, several instructions can be in different stages of execution at the same time. The "depth" of the pipeline is the maximum number of concurrent instructions that can be accommodated. Pipelines operate under the basic assumption that the instruction stream is located in consecutive locations in memory, so instructions are "prefetched" and decoded before they are needed.

A third feature that can improve performance is virtual memory. Virtual memory has been described as "making a machine with a lot of memory appear to have unlimited memory." This is of particular value to applications that use very large amounts of in-memory data. Code and data are assigned "virtual addresses" that are mapped by hardware to physical memory locations. In most cases, memory is divided into fixed-size "pages," typically 256 to 4096 bytes each.

Instead of forcing the application to manage movement of data between disk and memory, the system software takes over responsibility for doing so on demand. When a memory reference is made, the hardware determines if the page has been mapped to a physical location in memory. If not, a "page fault" occurs that system software must deal with before execution of the application can continue.

The fourth feature is the use of coprocessors to execute certain classes of instructions. The most common cases are the handling of floating-point operations and array processing. A coprocessor is a separate processor, usually with its own registers and internal features, which is attached to the system bus. When the CPU decodes an instruction that can be handled by the coprocessor, a signal is sent to the latter to cause it to perform the operation while the CPU waits. If the coprocessor isn't configured, a fault occurs. This usually results in software emulation of the coprocessor instruction by the operating system's fault handler.

tles on a minimal common subset, which may favor one processor over another.

A similar problem exists for comparisons between floating-point processors. Depending on internal architecture, it is entirely possible that one floating-point

processor might be optimized for execution of single-precision instructions while another is optimized for double-precision. For example, the first processor might be rated at 4 MFLOPS in single precision and 2 MFLOPS in double precision; the second processor could generate 3 MFLOPS in either mode. You could compare this situation to gasoline octane ratings. The ratings on the pump are actually the average of the "motor octane" and "research octane" ratings and represent neither one accurately.

Comparing Clocks

Another approach is to compare processor internal clock speeds, which are almost always expressed in MHz. The advantage to this approach is its simplicity; clock speeds are published for various systems' microprocessors. Ignoring any other factors, you can reasonably expect that increasing the frequency of the system's clock will result in a commensurate increase in processor speed.

The fallacy in comparing the clock frequencies for dissimilar processors is that they have little to do with each other. The number of clock cycles used by a processor depends very much on its actual implementation. The more exotic microprocessors, such as the Motorola 680x0 and Intel 80x86, require more clock cycles for address preparation and instruction decoding than their simpler cousins. As a result, a 68000 operating at 7 MHz in a Macintosh, Atari ST, or Amiga is not necessarily seven times as fast as an 8-bit 6502 running at 1 MHz.

Performance Constraints

These processor performance measurements are "best-case" situations subject to a number of constraints. Those who play the numbers game have a tendency to use these theoretical numbers for comparison without derating them to compensate for the fact that real workloads are not ideal. Here are some common factors that affect performance:

- **Pipeline breaks:** Among the techniques used to accelerate processing is the overlapping of instruction executions. Most high-performance processors use a pipeline technique wherein several consecutive instructions are in various stages of execution—from decoding to argument preparation to the actual operation—at the same instant. Transfers of control cause the partially processed instructions still in the pipeline to be discarded; such "breaks" greatly limit the performance of tight loops. (For a more detailed look at central processor func-

tions that affect performance, see the text box "The CPU Effect" at left.)

- **Memory speed:** If a processor is significantly faster than its system's memory, the processor will waste clock cycles waiting for data to be delivered. The processor can outpace memory by requesting more bits at a time than the memory is able to transfer. A 32-bit-wide request that can be satisfied all at once by 32-bit memory would have to be converted into a pair of consecutive 16-bit requests if the system were equipped with 16-bit memory. The processor must wait for both before proceeding.

- **Memory cycle stealing:** The memory-speed problem is made worse by configurations in which memory is shared between the processor and another high-speed active element, such as the video display chip. Because the processor and video chip can't access memory simultaneously, a means of sharing memory-access clock cycles must be implemented. The crudest form is to assign alternate cycles to the processor and video chip. It's common for the video chip (which must stay synchronized with the display) to be given the ability to "steal" cycles from the processor whenever it needs them.

- **Software inefficiencies:** Software doesn't automatically take advantage of the performance features built into the hardware on which it runs. While it is common for operating systems to check for such installed features as floating-point coprocessors and extended instruction sets, application programs usually don't. Unless performance becomes a problem, any optional features often will be ignored. This results in fewer trouble calls to the software developers at the cost of lost performance on high-end systems.

- **I/O and other system bottlenecks:** Very rarely is the CPU allowed to operate at full speed. There is almost always some limiting factor outside it, such as waiting for disk I/O (including reading a page in a virtual memory system). Even the normal operations of related components can cut into the processor's throughput. A real-time clock generates interrupts on a regular basis, which causes the CPU to set aside its processing, handle the interrupt, and resume.

Operating-system features, such as multitasking and virtual memory, provide solutions to the sharing of critical resources (i.e., CPU and memory) among multiple programs executing concurrently. This is not without cost, however; while total system throughput typi-

continued

cally increases, the performance of any given program is usually degraded.

In the case of virtual memory page faults, the performance impact is greatly increased by an embedded disk I/O request. If, for example, an application is actively using memory locations on 50 different pages, but only 40 physical pages are provided in its "working set," then 20 percent of its memory references are likely to generate page faults—and a subsequent performance degradation.

I/O and memory bandwidth are also factors. The time required to perform a single memory or disk access is subject to interference from other accesses. A disk unit can do only one request at a time, so a queue could form that forces new requests to wait for completion of those already outstanding. Even with adequate disk drives and memory, various system components have limits on the number of operations they can perform per second.

Other bottlenecks exist within system

software. Any system service that is used heavily has the potential for limiting total throughput. As system complexity has increased, the probability of contention between tasks for critical resources has also increased.

The "B" Word

Benchmarking has long been the norm for large computer acquisitions. A few such benchmarks have become standard measures of performance. Those who are concerned with computational performance have relied on the Whetstone benchmark (which also has a double-precision version) to rate system performance in Whetstones. Another favorite is the Sieve of Eratosthenes, which measures the efficiency of a compiler's generated code as much as it measures raw CPU performance.

Such standard benchmarks are most valuable to those whose needs match the benchmark. But for the rest of us, they are only indicators like other metrics.

I believe the best way to measure a system's performance is to load it up with the work you intend to do on it. This is the basis of a benchmarking process that will be most meaningful to you. You define a representative workload and then evaluate it on all the different systems under consideration. While not always possible, this sort of testing provides you with results that are virtually indisputable—from your point of view.

Test It Yourself

MIPS, MHz, MFLOPS, and the assorted other metrics all attempt to give a basis for comparison of various systems' performance. Each is valid within the constraints under which it is calculated; none is valid for all systems under all circumstances. As they say in the car ads, "Your mileage will vary." Take those results as a first-order approximation only.

The only real way to predict how well a system will perform for you is to test it yourself. Besides, a hands-on test will tell you a lot about both the system and the people you'll turn to for assistance. ■

Editor's note: For a further look at the muddled world of performance measurement and our attempt to make evaluations meaningful, see "Introducing the New BYTE Benchmarks," June 1988 BYTE.

Bill Kindel is a principal software engineer for Digital Equipment Corp. in Boxborough, Massachusetts. (The opinions expressed in this article are those of the author, and not of his employer.) He can be reached on BIX c/o "editors."

DATAPRO Means Accurate.

Information. We base our purchases on it. Formulate opinions from it. Make intelligent decisions with it.

Provided... it is correct. Inaccurate information is oftentimes less useful than none at all. It leads to misinterpretation. And in making a poor choice.

Datapro means accuracy. Our information services contain up-to-date documented reports on products and

services in microcomputers, information processing and data and voice communications. Reports that help you separate truth from fiction. And in today's ever-changing industry, that requires constant research and review. Our product and pricing comparisons are carefully developed. Technology reports are documented. User ratings are statistically analyzed. Competitive reports are scrutinized. And How-to-Advice columns are meticulously edited.

Start making your decisions based on the facts. To receive your free literature pack on Datapro's subscription services, call us today at 1-800-DATAPRO (1-800-328-2776) or use the reader service card.

datapro

All About Microcomputers	
Manufacturer	Model
Apple	Apple II
Commodore	Commodore 64
IBM	IBM PC
Intel	Intel 8086
Microsoft	Microsoft Windows
Oracle	Oracle Database
Parsons	Parsons Systems
PerkinElmer	PerkinElmer Instruments
Rockwell	Rockwell Computers
Sequent	Sequent Computers
Sony	Sony Computers
Tandem	Tandem Computers
Teracore	Teracore Computers
Trilogy	Trilogy Computers
Univac	Univac Computers
Wang	Wang Computers
Xerox	Xerox Computers

Art + 2 Years = Science

*The state of the art
in workstation graphics today*

Phillip Robinson

It's easier to say "state of the art" than to define it. It's easy to stare in wonder at a three-dimensional model of an airplane on a Personal Iris workstation from Silicon Graphics or to sit in stunned silence while a Tektronix workstation projects a stereographic image of the space shuttle. And there's no doubt these machines rate a place in any discussion of the state of the art in workstation graphics.

But there are other applications that also show the potency of workstation graphics, including powerful computer-aided publishing (CAP) and fast two-dimensional electronic CAD packages. These applications may not show the sophisticated and subtle color shading of a three-dimensional modeling program; however, they do display large areas of WYSIWYG text and graphics and can redraw complex overlays of colorful two-dimensional circuit diagrams within fractions of a second.

How do you determine the state of the art in graphics? What are the current products, concerns, and technologies for graphics on these 32-bit computing platforms? These are the subjects I'll be discussing.



First, I'll define the specific region of computing price and performance I'm talking about. After some drastic cuts in 1987 and 1988, the prices of 32-bit workstations dropped down to the top prices for personal computers. Apollo, Sun, and DEC (Digital Equipment Corp.) all offer entry-level workstations for around \$5000.

These price cuts stunned workstation

devotees, who expected 32-bit machines to remain at the \$20,000 level, leaping in performance but not dipping much in price. Clearly the competitive threat from microcomputers was serious. Most of the lowest-priced machines, however, were diskless "nodes" intended to work on a network.

For \$5000, you get a 32-bit CPU (typically a 68020, as in the Mac II), 4 megabytes of RAM, a 15-inch monochrome monitor, some version of Unix along with a windowing interface, and an Ethernet interface. Add a local hard disk drive, a color-display controller, and a large color monitor (typically 16-inch or 19-inch), and you're looking at \$8000 to \$10,000 or more.

As the RAM, hard disk drive, and monitor grow, the price grows too, up to \$20,000 or \$25,000. Some companies have different model numbers within that range (\$5000 to \$25,000) that substitute a different, faster CPU into the system. Hewlett-Packard, IBM, Silicon Graphics, Tektronix, and many other companies join the market when it is defined as extending up to the mid-twenties.

continued

Then comes a gray area. The personal workstations that are quite capable of *two-dimensional* work, such as CAP, computer-aided software engineering (CASE), electronic CAD (ECAD, or EDA for electronic design automation), and mechanical CAD (MCAD), peter out when assigned tougher tasks.

They give way to mid-range workstations that cost from \$35,000 to \$60,000 and are capable of three-dimensional graphics like those used for solids modeling, animation, simulation, and image processing. The mid-range systems boast more possible on-screen colors, graphics accelerators to speedily figure new pixel positions and hues, as well as more RAM, CPU MIPS (million instructions per second), and disk capacity.

Above the mid-range are the high-end or superworkstation systems that cost \$80,000 to \$100,000 and more. These are packed with yet more MIPS, specialized coprocessors for graphics, and even new architectures, such as multiprocessing CPUs. By then, you're talking about the gray area between workstations and minicomputers.

It's important not to forget terminals, which are still used in many circumstances. There are graphics terminals that contain special graphics-acceleration hardware. These can download primitive instructions from a mainframe or minicomputer and then perform the actual display work locally.

Looking up from PCs

Graphics on the IBM PC, Macintosh, Amiga, or Atari start from scratch, meaning to some people no more than the ability to display color on the screen. Progressive enhancements increase the number of colors available, the number of pixels on the screen, and the systems software for manipulating graphics primitives. Since the birth of the Mac, systems software often encompasses interface graphics such as windows, icons, and pull-down menus.

Few personal computers, however, even 80386 speed-burners or Mac Ix systems with multiple megabytes of RAM and floating-point processors, have any sort of hardware for accelerating graphics performance. They stick to the tried-and-true line of improving graphics performance by improving CPU power—that is, adding more system MIPS to speed the calculations involved in graphics. They may have special chips for sending the graphics bits to the display, but the actual algorithms of graphics—transforms, clipping, scaling, shading, and so on—are handled almost

entirely by software.

Some PC and Mac specifications match what you'll find in workstations. For example, the Mac II with Apple's own color-display board can produce up to 16.7 million different colors, displaying 256 at a time. That's the same as Apollo's personal workstations, for example, and is equivalent to 8 bit planes of memory for color (i.e., 2^8 colors). When a 24-bit color board is added to the Mac II, it can even display as many colors at a

F*ew*
personal computers
have any hardware for
accelerating graphics
performance.

time as the Personal Iris workstation.

There are also a few add-on boards for PCs and Macs that use standard graphics coprocessors, such as the Texas Instruments 34010 and the Intel 82786. Such chips can take graphics instructions from applications software and directly execute them without resorting to complex systems-software algorithms.

The Amiga comes with its own set of graphics coprocessor chips, and the Atari systems can take advantage of Atari's proprietary "blitter" chip for speeding graphics. The speed improvements from such accelerators can be enormous—as can the general graphics-calculation improvements that come from having a floating-point mathematics coprocessor. A personal computer with an added graphics coprocessor and a top-notch floating-point unit, such as the Weitek mathematics processors, may have more coprocessor firepower than many low-end workstations can boast, although adding the extras can also boost the *price* of the complete personal computer system beyond that of a workstation.

The systems at the top of this entry level can have proprietary graphics-accelerator boards or chips, high-speed CPUs, lots of memory, and other fancy hardware features, such as z-buffers for hidden-line removal. Most workstations also support graphics standards, such as PHIGS (Programmer's Hierarchical In-

teractive Graphics Standard) and X Windows under Unix, that provide some compatibility between different companies' systems and even between different models from a single company. Personal computers with extra coprocessor boards may be cut adrift from such compatibility, needing special drivers for each CAD or CAP program (typically including AutoCAD, VersaCAD, PageMaker, or Ventura Publisher) that they are able to run.

Frame Buffers, Z-Buffers, and Resolution

Most computer-graphics systems today use a display system with a "frame buffer" of RAM memory. This memory can be separate from the conventional RAM or can simply be an assigned part of it (as is the case in the IBM PC). Graphics information from the application program or systems software is converted into patterns in the buffer that change with program demands and is fed from the buffer to the screen at a regular, timed rate.

That rate must be quite fast in workstations, because there are so many pixels on a workstation display. The screen-refresh rate is physically determined by the display hardware and is kept high enough to eliminate bothersome flicker. Combine a large number of pixels with a high refresh rate, and you're looking at putting each pixel up every couple of hundred nanoseconds—leaving little time to calculate changes for a pixel and enter them into the frame buffer. This problem can be tamed a bit by adding double buffering to the system.

The "megapixel" is a common center-point for workstation resolution—1 million points on the display, although the screens range from somewhat under that (1024 by 800 pixels) to well over it (1600 by 1280 pixels). The higher resolution is typically used only in monochrome applications like publishing, where large pages need to be displayed on a single screen, showing both small text fonts and gray-scale pictures with their different monochrome intensity levels. Higher resolutions are not often mentioned as a prospect for workstations: More processing speed and colors are in much more demand.

A frame buffer with a single bit plane can only contain monochrome images: each bit is either a 0 or a 1 and translates into either an "off" or an "on" pixel, respectively, on the screen. Gray-scale images or color can be represented by multiple bit planes logically laid on top of each other with more than 1 bit of RAM

continued

Putting Workstations to Work

Thousands of applications programs exist for graphics workstations. Here are a few that exemplify the abilities, fields, and prices of the genre. They range from those that represent that two-dimensional foundation, systems-level software, to those at the true "state of the art" in animation and rendering.

Systems Software

The 68030-based workstation from NeXT runs the Mach version of Unix and comes with an object-oriented software "environment" called NextStep. The NextStep environment combines both applications developers' tools and a user interface. NextStep has four components—the Window Server, the Workspace Manager, the Application Kit, and the Interface Builder—which provide windows, menus, icons, and a simple process for putting building blocks of code together to form new programs.

NextStep uses Display PostScript as a device-independent graphics "library" for sending graphics information to the display. IBM has licensed NextStep for use on its own workstations. NextStep doesn't require any particular graphics hardware. It represents the first major endorsement of Display PostScript as a graphics software standard.

CASE

Athena Systems makes a CASE and simulation tool called Foresight for defining real-time software and hardware systems. It runs on Sun workstations

and uses graphical block diagrams and data-flow charts to represent physical processes.

Foresight can animate models such as heating systems, simulating their behavior to help find design flaws. Blocks can be connected hierarchically or in parallel, simulating sequential or parallel processing. Foresight is a two-dimensional application. It costs more than \$23,000.

CAP

Frame Maker, from Frame Technology, is another prime example of a two-dimensional workstation-graphics application. It is a CAP program that can integrate text and graphics on pages for books, newsletters, specification sheets, documentation, or just about any other sort of publication.

It can run on the least expensive graphics workstations—such as the Sun-3/50—and includes its own word processor, page-layout program, spelling checker and corrector, indexing ability, drawing program, and PostScript output routines. It costs about \$2500.

EDA

Electronic design automation, also known as electronic computer-aided design (ECAD), is a major part of the two-dimensional graphics market. Software abounds for designing and simulating VLSI chips, circuit boards, and even complete electrical systems. Mentor Graphics offers a variety of programs for drawing and "capturing"—that is,

converting into electronically logical files—circuit diagrams and then simulating the behavior of those circuits. These programs require color and run on a variety of workstations, including Tektronix, Apollo, and Sun.

Compact Software offers programs for designing and simulating radio-frequency and microwave circuits. Microwave Harmonica, for example (see photo A), can analyze and optimize any microwave nonlinear analog circuit under single- or multitone excitations. It has an interface to Mentor Graphics software and many other third-party programs to use schematics captured in those environments.

Microwave Harmonica runs on Sun, Apollo, HP, and MicroVAX workstations with two-dimensional graphics, typically using an 8-bit-plane system with 4 to 8 megabytes of RAM. It can link to the vector-processing abilities of supercomputers. Microwave Harmonica, and Compact's other similar programs for linear and gallium-arsenide circuits, use graphics for both the user interface and the output of results. Compact also offers an AutoArt II program for layout of the physical circuits. Some of the software also runs on personal computers.

The workstation software prices range from \$7000 to \$25,000 per user, depending on the number of users at a company. Efficient execution of EDA programs requires fast RAM architectures, timely bit-blit operations, and software routines that permit high two-

continued

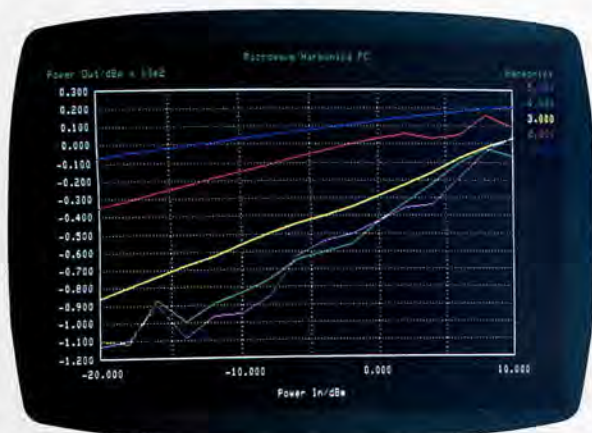

Photo A: A two-dimensional graphical display from *Microwave Harmonica*, a program for circuit design and simulation. (Photo courtesy of Compact Software.)



Photo B: A three-dimensional wire-frame display from *Anvil-5000*, a design and drafting program for mechanical engineers. (Photo courtesy of Manufacturing and Consulting Services.)

dimensional vector-per-second drawing rates.

Scientific Simulation

Creare makes a program called Fluent that models fluid-flow, heat-transfer, and combustion dynamics. It uses numerical-modeling techniques to solve various complex equations of fluid dynamics, and then uses graphics to plot the results of those computations. Fluent is used in automobile aerodynamic research and in studies of cooling towers and turbine machinery.

Fluent runs on MicroVAX, Tektronix, Apollo, Sun, Silicon Graphics, supercomputers, and mini-supercomputers (like those from Alliant). Prices depend on CPU power, ranging from around \$9600 a year to \$40,000 a year (on a Cray supercomputer). A typical installation might use a Sun-3/260 or Sun-4 with color and a floating-point processor. Because the computation is so central, high floating-point performance is more important than any particular graphics processor.

Three-Dimensional CAD

MCS (Manufacturing and Consulting Services) makes Anvil-5000, a general-purpose three-dimensional design and drafting program for mechanical engineers (see photo B). It runs on many different workstations and can handle everything from basic three-dimensional drafting to finite-element mesh generation and 5-axis numerical-control machining (CAM).

Anvil comes in six different modules—drafting, modeling, rendering,

finite element, simple machining, and advanced machining—and is sold on an annual-license basis. The cost ranges from \$10,000 a year for a basic system to \$38,000 per year for a loaded system. When Anvil is purchased for multiple “seats,” say a dozen or more, the loaded-system price can be cut in half for each seat.

Bechtel makes a program called Walkthru. The program takes a three-dimensional CAD model from some other program and allows you to interact with that model as you might in “the real world.” Using a three-dimensional color graphics workstation, a mouse, and a “button/dial” box with 8 dials and 32 buttons, you can “walk through” the model, controlling your imaginary body and head motion. Walkthru provides perspective, simulated views of the model—a boon to factory designers or architects. Walkthru runs on Silicon Graphics workstations. It demands at least 4 megabytes of RAM, 24 bit planes for color, z-buffering, z-clipping, and a button/dial box for input.

Solids Modeling and Animation

Intelligent Light’s workstation software is used in industrial design, illustration, scientific and engineering animation, video and film animation, and technical publication (see photo C). It runs on Apollo workstations (and soon on Stellar graphics supercomputers).

Intelligent Light offers tools for model building and scene creation (including placement of light sources and specification of surface appearance), animation, rendering (with Phong and

specular lighting, antialiasing, fog, and other special effects, including full color up to 96 bits per pixel), and image manipulation and recording. Images can be shown on screen or sent directly to videotape or slide. Prices range from \$30,000 to \$100,000.

Wavefront is the name I heard more than any other when I asked about “state of the art” in graphics software for workstations (see photo D). The firm sells a software package for three-dimensional dynamic imaging and high-end rendering and animation. The modules in this package are a modeler (a simple polygon modeler, not a full-fledged CAD package), a Preview module (for choreography of animation), and Image (for rendering—this module can crank away for many hours to create static images that are then put together for motion).

Image packs features such as shadows, ray-tracing, and reflectivity on the high end, and can also turn to lower-end work such as faceting, smooth shading, and the like. Wavefront software runs on many workstations, including all the Silicon Graphics machines and Tektronix and Hewlett-Packard mid-range systems. Prices start at \$23,000 and go up to \$55,000, depending on the platform’s performance.

Wavefront recently announced that it will offer its software for less than \$10,000, as a set of tools that other developers can use to add rendering to their own CAD or graphics programs or that neophytes can use with templates. The kernel of this kit will cost under \$2000.



Photo C: A three-dimensional solid display from Intelligent Light’s software for model building, animation, image manipulation, and so on. (Photo courtesy of Intelligent Light.)



Photo D: A display from Wavefront’s software for three-dimensional dynamic imaging and high-end rendering and animation. (Photo produced by Wavefront Technologies © 1988.)

assigned to each screen pixel. (The physical organization of the memory bits needn't be anything like the logical organization. The translation between the two is handled by video-memory drivers or controller electronics.) Monochrome images are often all that is needed for graphics applications like CASE or CAP, although gray-scale abilities can be handy for publishing or even just for pull-down menus and icons.

The least-expensive workstations are monochrome, single bit-plane systems. Low-cost color systems can get by with 6 bit planes, although 8 bit planes is more common for standard, inexpensive color. To simultaneously display any of the choices in a palette of 16.7 million colors, 24 bit planes provide "full color," also known as "true color." Some workstations also offer more bit planes specifically for use in pull-down menus or window identification (laying down borders that show where windows, menus, and icons begin and end—information a mouse or other cursor needs).

Advanced graphics systems also use *z-buffers* and *double-buffering*. A *z-buffer* is additional video memory that holds information about the *z* axis: which objects on the screen are in front of which other objects when seen in three dimensions. A *z-buffer* adds cost to the system because of the price of memory and its associated controllers, and it can even slow down some simple two-dimensional applications, but it can add sophistication to powerful solids-modeling programs.

Double-buffering uses more bit planes to hold multiple presentations of the same area on the screen. Screen changes are faster if all the display controller has to do is change which part of the frame-buffer memory it looks to, instead of updating the information in a single section and then redisplaying that.

Although frame buffers and *z-buffers* can be built from standard RAM chips, in workstations they are often built from the faster video RAM (VRAM) chips. These more expensive cousins to standard dynamic RAMs (DRAMs) offer two I/O ports or buses, allowing them to provide their data to the screen at the same time the CPU and graphics program are altering it. (Naturally, there is control over actually reading and writing the same bit at the same time.)

Scan Conversion, Transforms, Scaling, and Clipping

Graphics hardware can go far beyond the frame-buffer memory that holds the image, and the CRT or screen driver that moves that image out into view. A series

of operations must be performed before the appropriate pixels are placed in the frame buffer. The first is to generate a display list—a set of commands for graphics, such as "Draw a line from point A to point B," "Put a filled circle of radius *r* and center at (*x*,*y*)," or "There's a sphere of such and such a size at this point." Three-dimensional models may even make use of *nurbs*, or nonuniform rational B-spline curves, which are handy for representing complex shapes and curves. Moving them in software is a complex effort.

The display list is hierarchical, representing repeated parts of the complete image as subroutines that need to be detailed only once. The display list can be managed by the main system hardware or by a separate display-list processor that offloads the work from the CPU and so speeds up the entire graphics process. Most workstations have the CPU handle the display-list management, as do most personal computers. Some personal computer add-on graphics boards have a separate display-list processor, going beyond the typical hardware of a workstation. Graphics terminals often use display-list processors because so much of their graphics work must be done locally: The narrow bandwidth of the serial connection to a mainframe or minicomputer denies them the luxury of downloading completed graphics.

The primitives of the display list must be translated into individual pixels by a process called *rasterizing* or *scan conversion*. As part of this scan conversion, the computer must calculate how the picture looks from the viewer's perspective. If it's a three-dimensional image, the computer needs to know where in space the image is located, how big it is, and where the viewer's eye is in respect to the image. These calculations are called *transformations* and include *scaling* the object to the desired viewing size. Each point that describes the object must be transformed and scaled with respect to the viewer.

One specific operation that can streamline transformations is the bit-block transfer, or *bit-blit*. This is vital to the functioning of many windowing and other two-dimensional systems and has been built into a variety of hardware systems, including the Amiga's coprocessors and all of Apollo's workstations.

Then there are two *clipping* operations. The first concerns which part of the object the viewer is going to see. This is clipping in "world coordinates" or "clipping in the real world" and deter-

continued

Back, by popular demand.

Just a few years ago, illegal hunting and encroaching civilization had all but destroyed the alligator population in the south. They were added to the official list of endangered species in the United States.

Now alligators have made a comeback.

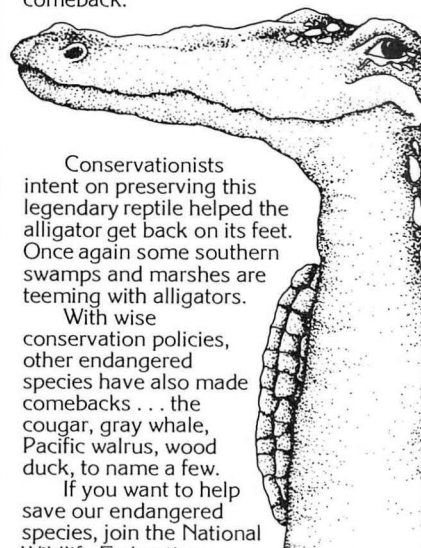

Conservationists intent on preserving this legendary reptile helped the alligator get back on its feet. Once again some southern swamps and marshes are teeming with alligators.

With wise conservation policies, other endangered species have also made comebacks... the cougar, gray whale, Pacific walrus, wood duck, to name a few.

If you want to help save our endangered species, join the National Wildlife Federation, Department 106, 1412 16th Street, NW, Washington, DC 20036.



mines which parts of the object need to be used throughout the rest of the display process. The second operation is "clipping against a window," where any parts that will fall outside the on-screen window are trimmed so they don't wrap around and distort the image, or waste processing time on parts of the image that won't be seen.

Finally, there are special operations, such as *antialiasing*, that serve to improve the look of a graphics image after it has been transformed, scaled, and clipped. Antialiasing turns selected pixels partially on to fill in the "jaggies" or "sawtooth" forms that can appear in diagonal lines or arcs. These effects can even distort the apparent image or cause distracting *moiré* patterns. Higher-resolution displays can also diminish these jaggies, but can be much more costly.

Wire Frames, Solids Rendering, and Animation

Three-dimensional graphics demand all the same operations as two-dimensional graphics, plus many more. These three-dimensional processes—which actually create a two-dimensional view of an imagined three-dimensional object—can be handled by any system as software algorithms. These processes are so computation-intensive and complex that they are practical only when handled in hardware.

There are actually three distinct styles of three-dimensional work: wire frames, solids rendering, and animation. Wire frames display the vertices and edges of objects, sometimes omitting the hidden lines and surfaces that are overlapped by closer lines and surfaces. Wire-frame work can be done with so-called two-dimensional workstations, although some of the work, such as hidden-line removal, will slow considerably without hardware assist.

Solids rendering or modeling uses *imaginary lighting and shading* to fill in the surfaces of a three-dimensional object. The latest trend in solids modeling is *photorealism*, which attempts to make the view of a simulated, displayed object as similar as possible to that of an actual solid object. Solids rendering can be done in many ways, with various operations and algorithms that yield varying levels of realism. Many of these algorithms can take an enormous amount of time if done entirely in software. For example, I have used the sophisticated ray-tracing algorithm option of the Solid Dimensions program from Visual Information. Running on a Mac II with its floating-point coprocessor, it can take 12

to 24 hours to render a single, simple scene with several uncomplicated objects.

Solids modeling has long been thought the province of "three-dimensional" workstations, the mid-range and high-end systems that have special hardware to speed the rendering algorithms. In fact, the terms "low-end workstation" and "two-dimensional workstation" were often synonymous. Silicon Graphics' introduction of the Personal Iris brings

Silicon Graphics' Personal Iris brings solids modeling into the league of personal workstations.

hardware-assisted solids modeling into the league of personal workstations.

Animation demands even more from a computer system, with the ideal being real-time animation: the ability to generate rendered solids quickly enough to simulate objects in motion. This means at least 10 display changes per second. The animation can be done in non-real time, calculating frames one at a time, and then saving them in mass storage for viewing in sequence later, or sending them to a videotape peripheral.

Animation is not only useful for art and commercials but has been put to work in presentation graphics for design proposals, for analyzing the fit and interaction of mechanical devices, and for modeling fluid flow in many fields. Animation has been handled on everything from the best mid-range workstations to supercomputers. It is becoming a reality in the low end with the introduction of the Personal Iris.

Depth Cueing and Hidden-Line Removal

One three-dimensional technique is called *depth cueing*. It varies the pixel intensity relative to the distance that pixel represents from the viewer's eye. Both depth-cueing and hidden-line-removal techniques depend on a z-buffer.

To render a wire frame with a solid ap-

pearance, the hidden surfaces must be omitted and the visible surfaces of the object must be filled with color or gray-scale shades. Hiding background edges and surfaces can be done with several levels of transparency, ranging from opaque to "screen door" (where a pale transparent shade fills the closer surface), which gives the illusion of looking through a fine mesh.

Some operations are more appropriate to two-dimensional than three-dimensional applications and serve mainly to slow down three-dimensional operations without improving the quality of the image. Antialiasing, for instance, isn't as important in three-dimensional solids where the shaded fills will provide some of the same smoothing. It can even make the images fuzzy. In three-dimensional wire-frame work, however, antialiasing can still play a role.

Gouraud and Phong Shading, Ray Tracing, and Radiosity

When it comes time to fill a surface, there are many different algorithms or schemes for determining the particular shade or color for each surface or pixel. The simplest operation is *constant shading*: A model is broken logically into polygons that will show on-screen, and a single shade or color is assigned to each entire polygon. This is a quick rendering scheme, but it creates distortion when side-by-side polygons have two shading levels. You'll be able to see a line of delineation between the two that will show as a facet of the object and may not be intended as such.

The Gouraud algorithm provides one way to ameliorate that distortion, by linearly changing the shading across each polygon. The algorithm samples two opposite edges of the polygon and then shades across the face between the boundaries. This removes abrupt shading changes and can be done in software or hardware. It is usually made a part of the scan-converter hardware in high-end graphics workstations.

The Phong algorithm is more exacting than the Gouraud. Instead of polygon-by-polygon examination and linear averaging, Phong looks at individual pixels. That makes it much more time-intensive than Gouraud as well. Gouraud shading can approximate Phong shading, however, by making the polygons smaller and smaller.

Ray tracing and radiosity are some of the most advanced operations in the pursuit of photorealism. There are two types of surface-reflection effects: specular and diffuse. Specular reflection has a

shiny effect, bouncing back light as though from a smooth surface. Diffuse reflection does not directly reflect as much light, instead spreading it out in more directions as though from a rough surface.

Ray tracing is a specular effect that traces each light ray from the assumed viewer's eye to the surfaces in a three-dimensional graphics image. The ray is bounced mathematically from one surface to the next until it reaches a non-reflective surface, and its lighting effects are noted. Even for a workstation, this can take some time, particularly without hardware assist and acceleration. Software can contain the compute task for ray tracing somewhat by limiting the number of rays traced.

Radiosity is a diffuse-lighting effect. It takes the diffuse light that reflects off each object in a scene and calculates the impact that light will have on adjacent objects. These calculations could be done in software, but again, that would take hours unless aided by special hardware or given a time limit. Hewlett-Packard's mid-range SRX workstations include hardware for Gouraud and Phong shading with programs for radiosity modeling with progressive refinement in software (see photo 1).

MIPS, MFLOPS, LINPACK, Vectors, and Polygons

Any graphics effect could be created by nearly any computer, given enough time. However, graphics performance is typically measured in terms of speed. This was aided by an IBM study in the early 1980s showing that productivity on a computer was very closely related to the graphics speed or "interactivity" of the display. If the picture on the screen could update in less than half a second, productivity was at a peak. Between half and three-quarters of a second, there is a very sharp "knee" in the graph where productivity falls. That half-second update is what most workstation manufacturers aim for as a minimum. Markets such as animation—which requires a minimum of 10 frames a second—need even more speed.

The simplest speed measurement is the power of the system CPU, typically measured in MIPS. This is a good first cut at graphics power because most personal workstations end up doing a lot of graphics work—both applications computing and graphics scan-conversion algorithms—in software. The MIPS measurement ranges from the 1 or so DEC VAX 11/780 MIPS of an 80386-based personal computer to the 7 or 10 MIPS of

the SPARC-chip-based Sun-4 system or the RISC-chip-based Personal Iris from Silicon Graphics. Adding a floating-point mathematics coprocessor can boost the system's MIPS.

In fact, floating-point performance is so important in graphics that MFLOPS (million floating-point operations per second) are often used as a yardstick in place of MIPS. A system still needs a good measure of MIPS to handle the standard computing tasks, so the ratio between MFLOPS and MIPS shouldn't get too big, or the graphics task could become compute-bound by standard applications work. The Personal Iris claims a 10-MIPS CPU with a 20-MFLOPS peak graphics processor. When you're hearing tales of great MFLOPS, however, you should inquire about their origin: Peak MFLOPS can be much higher than the MFLOPS rating from a standard program such as the LINPACK benchmark, a 100 by 100 matrix calculation in double precision.

Even with such standardization, different machines will be faster on different tasks, depending on which graphics operations have been built into hardware, optimized in software, or left to generic software routines. The number of vectors drawn per second (for two-dimensional and wire-frame images) and polygons drawn or shaded per second (for three-dimensional solids-modeling images) are

other measures of performance. You'll often see a sequence of these lined up in workstation specifications, with values in the tens and hundreds of thousands, depending on the workstation model and graphics options. A system with Gouraud shading in hardware will be much faster on that operation even though it has a lower MFLOPS rating on FORTRAN programs and may even have a lower bit-bit speed on two-dimensional images.

Workstations sometimes can be linked together in a network to grind away at complex graphics tasks. Apollo, for instance, can use its Network Computing System (NCS) to dish out parts of a complex graphics-calculation task to other workstations and their CPUs' MIPS. (Hewlett-Packard has recently licensed the NCS for its own systems.) The result can then be displayed on a single workstation.

Libraries and Device Independence

All the hardware power doesn't exist in a vacuum. Applications developers love to have some sort of standard graphics device to which they can adapt their programs. Workstation hardware tends to differ much more than hardware in the personal computer arena. Although the 68020 is the most standard CPU (and plenty of others are in use), workstations have different addressing and memory

continued



Photo 1: The ray-tracing feature of the HP 9000 TurboSRX engineering workstation from Hewlett-Packard allows you to produce the realistic highlights, reflections, and effect of transmittance seen in this screen shot. (The data to produce this image is courtesy of Chrysler. Photo courtesy of Hewlett-Packard.)

schemes and graphics architectures.

This diversity makes it tough for you to create a program that will run on many platforms. Unix has certainly become the overwhelming standard in operating systems at the low end of workstations, although there are various flavors of Unix, from IBM's AIX to NeXT's Mach to Sun's hybrid of System V and Berkeley 4.3. For real-time operations, such as process-control graphics, there are special Unix versions, such as that from Masscomp, and DEC's VMS operating system. Plain Unix is not well-regarded for real-time work.

There are also standards that concern graphics itself. For the past 5 years, the de facto standard has been ANSI's Color Graphics Virtual Device Interface. You could just write a program to call the CGVDI circle command, cube command, or whatever, and let the workstation vendor worry about the interface between the standard library of graphics routines and the proprietary hardware. CGI (a common abbreviation of CGVDI) was a fairly simple two-dimensional standard now being replaced by PHIGS.

PHIGS is also a two-dimensional standard, but it's more advanced and is hierarchical, which lets it call subroutines for efficient code execution and size (see the article "PHIGS: Programmer's Hierarchical Interactive Graphics Standard" by Martin Plaehn in the November 1987 BYTE). It's a programming base that a graphics application can use: Make your program call on PHIGS graphics primitives, and it will run on any workstation supporting PHIGS (most do). PHIGS+ and PHIGS++ are proposed extensions that include curved surface, shading, lighting, depth cueing, and other three-dimensional paraphernalia. However, PHIGS does not come with windowing tools.

Another device-independent graphics standard is X Windows. Like PHIGS, it's a set of routines that an application program can call on. But X Windows allows for distributed graphics: An intensive calculation application can run on a high-powered server and display the results in a window on a personal workstation. It's a toolkit for implementing window systems and displaying two-dimensional graphics. X Windows does not include three-dimensional abilities. An adjunct group to the X Consortium (that came up with X Windows) is working on PEX (PHIGS Extensions to X Windows), which would merge PHIGS+ with X Windows. This would use X Windows to manage the window environment and PHIGS+ to render the graphics.

Two other possible standards of interest to personal computer users are the HOOPS graphics library from Ithaca Software and Display PostScript from Adobe. HOOPS is an object-oriented set of routines that has been implemented on a number of personal-computer products, including a transputer-based IBM PC plug-in board from Nth Graphics. Display PostScript has been used by the NeXT workstation and has a direct relationship to the PostScript that is in so many laser printers, but it hasn't made a dent in workstation graphics software.

There are also proprietary standards, such as Apollo's three-dimensional Graphics Metafile Resource File, Hewlett-Packard's Starbase, and Silicon Graphics' Library. IBM, which has not had much success with its own RT workstation, recently licensed SGI's library and graphics accelerator chip for use in its own workstations.

Database Design and File Formats

Another important subject in graphics work is the structure of the databases that

comprise graphics images, and the files used to transport them among different applications and workstations. Although flat files and relational databases were once used, these are being challenged by object-oriented databases. An OODB stores an image as objects with properties. This makes the translation from application to screen display less complex. It also suits the graphics application code to object-oriented languages such as Smalltalk and C++, with their attendant extensibility, reusability, and prototyping ease during programming.

For capturing and transferring graphics, the latest proposed standards are Computer Graphics Metafile and RenderMan. CGM allows you to take a picture file from one system and run it on another. RenderMan is newer and not as well-established, but it includes more sophisticated information on the three-dimensional aspects of an image.

The Roster of Players

There are a lot of players in the workstations game and a lot of applications (see the text box "Putting Workstations to Work" on page 257). Because workstations have windowing systems and some ability to handle monochrome two-dimensional graphics on large displays, all could be considered graphics powerhouses next to the average personal computer. However, some workstations rise above the rest because of special graphics hardware built in or available as an option within the personal-workstation price range.

- *Silicon Graphics*. The most likely winner this year of a "Heisman trophy" in workstation graphics is the Personal Iris from Silicon Graphics. Begun in the early 1980s by a Stanford professor, Silicon Graphics has specialized in applying

PC voice mail, now only \$199.

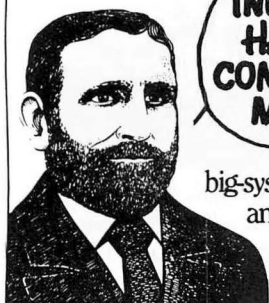

INCLUDES
HAYES®
COMPATIBLE
MODEM!

Watson®, hailed by one reviewer as "the premier voice mail station" at \$498, is an even better value at \$199. Watson eliminates telephone tag and gives you big-system features like auto speed-dial, auto answer, message forwarding, and built-in 300/1200 bps modem. For an ear-opening business applications demo,

call **1 (800) 6-WATSON** (in Mass., (508) 651-2186). To order, call **1 (800) 533-6120** (in Mass., (508) 655-6066).
Credit Cards Accepted.

Watson®

Natural MicroSystems Corporation

VLSI and its own optimized library of graphics routines to three-dimensional graphics.

The Geometry Engine VLSI chips that made its Iris workstation a hit at the mid-range and high end of the market for animation, simulation, medical imaging, and mechanical design CAD are now built into the less expandable—and far less expensive—Personal Iris. For just under \$17,000, you can buy a Personal Iris diskless system with a 10-MIPS CPU (the R2000A RISC processor from MIPS Computer), 8 megabytes of RAM, 8 bit planes for color, 2 bit planes for menus, 2 bit planes for systems administration (all using VRAMs), and a Geometry Engine.

The system can drive a 19-inch, 1280-by-1024-pixel color display with real-time animation of 10 frames per second, performing 200 calculations every second for every pixel on the screen. Expansion to 24 bit planes for color, 8 system bit planes, 155 megabytes of hard disk, and a 24-bit z-buffer runs the price up to nearly \$30,000. That's still far less than the bottom price of the mid-range Iris 4D70 (at \$44,000) or a competing three-dimensional workstation such as the Sun-4/260, Apollo 590 Turbo, or HP 360SRX Turbo—all mid-range workstations. Lighting, specular highlights, and scan conversion are built into the accelerator hardware of the Geometry Engine, which can pump out 85,000 three-dimensional vectors per second. The Personal Iris supports PHIGS.

- *Hewlett-Packard.* HP has a variety of personal workstations for two-dimensional graphics, and mid-range systems for three-dimensional work. The newest personal-workstation system is the HP 9000 Model 340 series, based on the 68030 CPU and 68882 FPU. The 340s have at least 4 megabytes of RAM and HP-UX Unix, and they support X Windows and PHIGS.

The lowest-price unit in the 340 series, at just above \$5000, is the 340M, a 1024-by-768-pixel monochrome system for mechanical design and drafting. The 340C+ is a nearly \$9000, 6-bit-plane color, 1024-by-768-pixel, two-dimensional system with hardware support for vector and polygon drawing and fills. The 340CH is an \$11,000, 8-bit-plane color, two-dimensional system that starts from the 340C+ base.

The \$16,000 340CHX is a CH model with a plug-in, integer-based graphics accelerator (with a 68020 processor) that can double display-processing performance—taking charge of the transform

and clipping calculations.

Hewlett-Packard uses a “strip z-buffer” that takes advantage of unused memory in the mainframe-buffer area (the typical resolution of displays doesn't match exactly with the size of standard memory chips and chip sets). This saves money on memory for a small expense on increased memory-controller overhead. The systems all come with an HP-HIL interface (HP Human Interface Loop) that can daisy-chain input devices such as mice, knob-boxes (a suite of dials that can be turned to, for instance, change each of the rotations and positions of a three-dimensional simulated object), tablets, and so on. The 340SRX incorporates silicon assists for solids-rendering work, such as light sources, Gouraud shading, and transparency. The 340 series is not as expandable as the 360 and 370 series (also 68030-based) mid-range workstations, but it is more expandable than the 318 and 319 families it replaces. It is object-code-compatible with the other HP 9000 Series 300 workstations.

- *Apollo.* The 68020-based Series 3000 is Apollo's lowest-priced workstation, with an estimated CPU performance of 1.5 MIPS. Above that are the Series 3500 and Series 4500. The 3500s have a 68020 and boast a performance of 4 MIPS. The 4500s have a 68030 and a 68882 FPU for a performance of approximately 7 MIPS. You can get the 4500 with 15- or 19-inch monitors, in 1280-by-1024-pixel monochrome, 1024-by-800-pixel, 8-bit-plane color, or 1280-by-1024-pixel 8-bit-plane color. The 3500 adds a 1024-by-800-pixel monochrome option to that list.

All these systems are aimed at two-dimensional and three-dimensional wire-frame applications. The 3000 does not contain special graphics accelerators other than bit-blit assist in hardware (essential for windows and polygon fills). Instead, it depends on general floating-point performance and an optimized library of graphics routines for graphics speed. A Weitek 3164 FPU option is available for each system. The 3500 and 4500 have a dedicated graphics processor for accelerating the drawing of two-dimensional primitives.

The systems run under Unix and support PHIGS, X Windows, and Apollo's own three-dimensional Graphics Metafile Resource File library. All of Apollo's graphics workstations, including its mid-range and high-end Turbo Domain systems, are binary-compatible—meaning a single program can run on any of

them without even a recompilation, using whatever graphics abilities are available. While you can get a Series 3000 monochrome, diskless node for around \$5000, a 3500 color system without disk runs just over \$12,000. The 4500 systems start at \$19,000 (diskless, monochrome) and rise to \$35,000 and higher (color, 348-megabyte disk drive). The mid-range and high-end Apollo workstations include up to 24 bit planes for graphics and hardware assist for three-dimensional algorithms.

- *Digital Equipment Corp.* DEC offers three personal workstations for graphics: the VAXstation 2000, the VAXstation IIGPX, and the VAXstation 3200. The 2000 comes in monochrome and color versions, beginning at just over \$5000 and just under \$8000, respectively. The 2000 is built around DEC's own MicroVAX II chip set with its own FPU, 4 megabytes of RAM, and 1024-by-864-pixel display resolution. The monochrome system has a single bit plane; the color system has 4 bit planes. Eight-bit-plane color models are available and cost \$13,000 to \$18,000. The graphics chips in the VAXstation 2000 are the same as in the VAXstation IIGPX. GPX prices begin at just under \$20,000. This workstation is larger, with more memory and disk capacity than the VAXstation 2000. A diskless, 8-bit-plane color system runs nearly \$23,000. Both the 2000 and the IIGPX are built around the MicroVAX II engine.

The VAXstation 3200 uses a CMOS version of the MicroVAX II engine and FPU, along with a dual-cache memory, and so is much faster on all system measurements. A color 3200 system starts at \$29,000 and comes with special graphics coprocessors from DEC. These GPX coprocessors perform bit-blit, scaling, clipping, fill, and scrolling operations in hardware. Support for PHIGS and X Windows is included.

On the high end, DEC has developed the VAXstation 8000 three-dimensional real-time graphics workstation with Evans & Sutherland (famous for its flight simulators and other high-end graphics computers). The Evans & Sutherland graphics engine in the 8000 handles 24 bit planes double-buffered with Gouraud and Phong shading and up to 16 light sources.

- *Sun Microsystems.* Sun has three different architectures for personal workstations, from the 80386-based 386i to the 68020-based Sun-3 and the SPARC

continued

RISC-chip based Sun-4. The 3/50 is the lowest-priced unit, at about \$5000 for a diskless, monochrome system with 1152-by 900-pixel resolution. The lowest-priced color system is the 3/60 with 1152-by 900-pixel resolution for gray scale or color, and an option of 1600 by 1280 pixels for high-resolution monochrome. These systems are aimed at two-dimensional applications, such as mechanical CAD, CASE, and publishing.

The 386i can produce 1152-by 900-pixel monochrome or 1024-by 768-pixel color. These systems support PHIGS and X Windows, but they have little in the way of hardware acceleration for graphics. Above these machines are the 4/110 and the 4/150, which cost \$20,000 and more. The 4/110TC includes a graphics option with 24 bit planes for color.

In the mid-range systems, Sun offers a CXP graphics accelerator option. At the high end, there's the TAAC image-processing option that has hardware for manipulating entire images—such as converting a series of CAT-scan images of a heart into a simulation of the heart beating. The TAAC boards alone cost about \$30,000.

• **Tektronix.** The 4319 is the entry-level workstation from Tektronix, with a 68020, 68881 FPU, X Windows, and 1280-by 1024-pixel resolution. It comes with Tektronix' own Color=Cache chip for bit-blit in hardware, and it can handle up to 8 bit planes for color. The 4320 series of workstations, from the \$23,000 4324 to the \$27,000 4325, is aimed at two-dimensional applications and is also built around a 68020 and 68881. Resolutions of 1024 by 768 and 1280 by 1024 pixels come from a separate 68020 dedicated to graphics and a special bit-slice processor accelerator.

The Tektronix 4330 family is a three-dimensional, mid-range series of workstations (from \$37,000 to \$52,000) with a fascinating graphics capability: stereographic viewing. These workstations boast 24 bit planes for color, z-buffers, and double-buffering, as well as the separate 68020 and accelerator chips for graphics you find in the 4320 series. Depth cueing is built into the standard display, and an optional system that alternately displays left-eye and right-eye views produces three-dimensional images when you look through special

polarized glasses. Any three-dimensional application that supports Tektronix three-dimensional terminals and workstations can run in the stereo mode.

• **Others.** There are lots of other workstation makers with impressive graphics. IBM and NeXT haven't sprung unusual graphics hardware on the public, but they have recently put impetus behind Display PostScript (in the NeXT workstation) and NeXT's NextStep application environment (which IBM has licensed).

Intergraph makes a variety of workstations, including some new mid-range systems with multiple megapixel displays. And there are graphics terminals that can unload some of the work from workstations—such as the Seiko GR4400 that has hardware for Phong shading and the GX4000 from Raster Technologies that supports PHIGS and PHIGS+ with a parallel-processor architecture. If you can spend more, you'll find systems such as Apollo's Series 10000 that can use 40 or 80 bit planes with z-buffers, double-buffering, and 4 processors to make as many as 600,000 polygons per second.

Capabilities Up, Prices Down

There are two clear indicators to what you'll be seeing in personal-workstation graphics next year and the year after that. First, look at the mid-range systems: z-buffers, depth cueing, shading in hardware, and the like. Resolution probably won't climb much, but three-dimensional systems will certainly follow the Personal Iris into lower prices. Perhaps Tektronix' Stereoscopic Display will catch on.

The other indicator comes from the arts. According to John Metcalfe, the director of marketing for entry-level systems at Silicon Graphics, "The animation industry drives us. They want to see real life on a workstation—and that drives us from a technical point of view. About 2 years later, the mechanical-design people decide they want that same stuff, even though if you had asked them what they wanted before, they probably wouldn't have mentioned it." ■

ACKNOWLEDGMENT

Special thanks to Roger Jollis of Hewlett-Packard for his help in explaining shading techniques to me.

Phillip Robinson is an editor for Virtual Information (Sausalito, CA), where he researches and analyzes trends in the computer and workstation markets. He is a contributing editor for BYTE and can be contacted on BIX as "robinson."

People are talking about us.

When professional FORTRAN programmers develop or port large programs they use Lahey's F77L-EM/32 and F77L-EM/16, *PC Magazine's 1988 Technical Excellence Award Winners*. F77L-EM/32 is a fast 32-bit protected-mode compiler that accesses up to 4 gigabytes of memory on 80386s. F77L-EM/16 gives 80286 users the power to create 15 megabyte programs. These protected-mode FORTRANs include the features that have made them, and our F77L and Lahey Personal FORTRAN, market leaders: full ANSI 77 Standard, VAX and IBM VS extensions, fast compilation, comprehensive diagnostics, and a powerful debugger.



When people talk about FORTRAN
the name mentioned most often is



Contact us to discuss our products and your needs. (800) 548-4778
Lahey Computer Systems, Inc. P.O. Box 6091, Incline Village, NV 89450
Tel: (702) 831-2500 FAX: (702) 831-8123 Tlx: 9102401256

Networking with Unix

*RFS and NFS provide the key
to distributed file systems*

Greg Comeau

If you own a Unix workstation, chances are at some point you will want to network your machine to other computers so you can access their files and resources. Sun Microsystems' Network File System (NFS) and AT&T's Remote File System (RFS) allow you to do just that. These file-system arrangements, however, go about their business in very different ways.

To understand their strategies, you should first understand a few points about Unix. A typical Unix workstation takes advantage of a hard disk's cylindrical layout and zones specific contiguous cylinders into file systems.

For instance, most Unix machines contain at least two file systems: one system that contains the Unix environment, and another that contains user files and programs. Other Unix machines contain local file systems as well. Since each file system usually contains a directory structure (which consists of directories, files, and devices), they are handy for structuring your disk into unique and specific areas suited to your needs.

Unix adheres to hierarchical file systems, which many users are familiar



with. Note, however, that a reference to a path, such as `/usr/comeau/dir`, could have many variations under Unix because the operating system is based on the concept of a root file system. In other words, the root file system is your system's main file system. All subsequent file systems—for example, `/usr`—must be mounted atop the root file system.

Unix does this by overlaying a file sys-

tem hierarchy structure onto an existing directory. The directory may or may not be empty. Therefore, access to a path such as `/usr/comeau` happens transparently without the person or process who is actually accessing the path knowing that `usr` is just a logic connection to `/`.

This differs from other systems, since each system administrator has the power to mount any unmounted file systems onto any directory that exists on a currently mounted file system.

This setup works out nicely for several reasons:

- Your machine need not be concerned with file systems that contain projects not currently being used.
- Introducing a file system is as simple as mounting it.
- You can access all mounted

file systems transparently because they adhere to the directory structure. (For example, you can mount `usr` on `/` to obtain `/usr`.)

• Since file systems are constrained to cylinders on a disk, you can easily add file systems from different physical disk drives on the same machine to the current file-system state.

continued

Although this all works reasonably, *unfortunately* it locks you into accessing file systems located on the machine you are logged onto. You can access remote machines via file-copy protocols, usually the Unix-to-Unix copy program `uucp`, but this can be awkward.

RFS and NFS let you transparently connect the file systems of one computer to the file systems of another. They enable your Unix machine to use the file system of another Unix machine so naturally that you may not always realize that you are using another computer's resources.

How RFS Works

RFS ensures that all network transactions adhere to Unix I/O semantics. In other words, `open()`, `close()`, `unlink()`, and so on, and even `ioctl()` all behave so rationally that files are always left in manageable states.

The transparency is so strong that reliability, security, and even simultaneous access to files all occur as if on one Unix machine. Of course, this implies correctly that RFS was intended to be used only for communicating with other Unix systems.

RFS functions depend on a machine supporting a transport provider. The TP ensures that there is a physical network along with the appropriate software to drive the hardware of the network. The hardware is typically Ethernet, System Network Architecture, or StarLAN. The software is broken down into two software layers to handle the network protocols.

The software subsystem works by using an I/O facility called Streams. With Streams, you can connect to one of several network protocols (i.e., Transmission Control Protocol/Internet Protocol, Ethernet, and so on) for your inter-machine communications needs. The end result: RFS is *network-independent*. That is, since it can be independently configured regardless of the underlying hardware, it need not be pinned down to a specific protocol, vendor, or machine.

Streams accomplishes this via handlers, each of which is a different layered protocol in software. Each handler usually interacts directly with the hardware and converts the real protocols into a common format so that the higher layered protocol handlers (the ones Unix would interface with directly) all map into a common protocol.

The RFS scheme consists of client and server machines living within a domain. Machines within a domain that advertise their file systems for other machines in

the domain to use are called server machines. (For a glossary of basic terms, see the text box "The Nomenclature of Networking" on page 269.) Machines that use the advertised file systems by mounting them are called clients. Since a server can choose to use a file system of another machine, some machines will be both servers and clients.

Furthermore, one machine in the domain is chosen by the domain's system administrator as the primary server. It maintains various lists. The most important of these is the list of directories, files, and even devices that were advertised for network usage. Other lists help maintain network security. Among other abilities, these security lists can restrict specific machines to a given network resource, as well as specific groups or user IDs.

Generally, once these files are set up across all the machines in a given domain, each machine advertises what it has to offer as it boots up, as well as mounting resources it needs from other machines. This results in very little network maintenance once the distribution directories and files for each machine have been determined. Besides its adherence to the Unix I/O semantics, this is another reason why RFS is so transparent.

Good Points and Bad

One problem with the RFS scheme is that the state of the network is more fragile since it enforces the Unix I/O semantics. Because of this, if the primary-domain server fails, the secondary-domain servers, chosen by the domain's system administrator, temporarily assume the primary server's responsibilities until it is restored and rebooted.

Interestingly, this doesn't particularly affect the network, since machines currently in the network have already advertised their resources and mounted those that they needed; therefore, current mount points will not be broken. However, it does affect any machines in the domain that have been booted in the interim.

Since RFS ensures Unix I/O semantics, users and programs can make directories, files, devices, and named pipes across the network without concern for where those entities really are. The lack of concern results from the ability to always have a consistent view of a file. In other words, database accesses and file locking perform as you would expect from a single machine. This is nice, since Unix should act like Unix whether or not it is connected to a network.

Furthermore, because security enforcement is at a machine, group, user, and Unix level, network security is never at a disadvantage because of RFS. One indirect problem of this, though, is that machine administrators choose to advertise all the file systems of their machines to all the clients of the domain, and users may be given the chance to read or write files they shouldn't have access to. This is strictly an administration concern, though, since the default choice is that a given file system or entities within a server will not be shared.

All this consistency has a price. Because of it, the network has the potential for more traffic, resulting in a loss of performance and more bottlenecks.

At first glance, the ability to selectively mount remote file systems within selected directories on a given client seems rather powerful. Looking at this in detail, you see that each machine has its own different view of the network. This may be fine for a given machine, but if you or your programs are relying on a consistent directory tree or on access to a specific path name, these different views can become confusing and error-prone in some situations.

What Makes NFS Tick?

NFS's general setup is similar to that of RFS. A few differences, however, point out their distinct tactics. Although they both hinge on the ability to treat a remote file system as being local, they do so in different ways. Mainly, NFS is not a network extension of Unix and therefore does not attempt to adhere to Unix semantics. In fact, it takes this difference one step further and allows other non-Sun and non-Unix operating systems to use it. Since the protocols for NFS are in the public domain, some vendors have endorsed its use, and Sun even developed a Unix-to-MS-DOS network connection called PC-NFS.

Even with these differences, the internal makeup of NFS is not unlike RFS when it comes to network accessibility. An advertising mechanism for servers and a mounting ability for clients still exists. Also, instead of the network layering associated with Streams, NFS has substitute mechanisms called Remote Procedure Calls (RPC) and External Data Representation (XDR).

Since remote file systems need only appear to be real Unix file systems, NFS implements a Virtual File System mechanism. For instance, the Unix file system usually accesses files through an operating-system disk handle called an *inode*. Since the remote file system being

accessed doesn't need to use the Unix file-system structure, NFS uses VFS to construct a *vnode*, a virtual inode. As long as VFS can do this, NFS can exist as a machine- and operating-system-independent application.

VFS is smart enough to determine if a request is from the local machine and will resort to using standard file-system operations in that case. When the request is remote, it will issue RPCs. An RPC can be thought of as a client process issuing a procedure call to a server process just as if the procedure call had occurred on the client machine. Under this scenario, a client calls a local procedure to issue a network request or data transfer. A message is sent to the server in response to the client procedure call, upon which the server runs whatever procedures it needs to fulfill the request and then returns to the client's local procedure call with the answer.

An RPC request, which uses XDR internally, transfers data and messages. Because of the diversity of machines and their CPU architectures, XDR is a common machine-independent protocol to be used at the lowest layer of NFS. This means that data structures used by your programs—whether they are base types or types derived from the base types from any machine—can be transparently described, transmitted, and converted to more than one machine. All this can be done regardless of machine architecture. The combination of RPC and XDR provides the equivalent of the standard I/O (`stdio`) library package that is commonly found in C programming environments.

The network address list and advertising list, such as those found on the primary domain server under RFS, are found through the Yellow Pages. The Yellow Pages is simply a read-only database for NFS.

Pros and Cons

NFS has major concurrency problems because it isn't a Unix network extension. This also means NFS doesn't support all Unix file-system operations, can't obtain access to remote devices, can't support file locking, and can't support file-append operations.

These problems, however, do have their benefits. To begin with, NFS need not be used only for machines supporting Unix file systems. Therefore, it's both machine and operating-system independent. Second, because NFS and its underlying protocols (VFS, RPC, and XDR) are in the public domain, implementations on diverse hardware and op-

The Nomenclature of Networking

Here's a glossary of basic networking terminology to help you understand the Network File System (NFS) and the Remote File System (RFS) schemes:

- *Networking address or node name.* The unique name of a machine in the network.
- *Resource.* A file, directory, subdirectory, device, or logical pointer to them.
- *Client.* A machine that requires access to the network to obtain resources of other machines.
- *Server.* A machine that donates its resources to the network.
- *Primary server.* The network master, responsible for maintaining the node names and resource identifiers of the machines in its domain. Clients communicate with the server to advertise their resources to the domain or to query it for a resource of the domain.
- *Domain.* The network area controlled by the primary server. Under RFS, a domain serves many purposes. It allows easy access to the domain via a predetermined name; controls security via a domain member list; allows clients in the domain to contact other clients directly; and allows clients to contact other domains.
- *Distributed file system.* A file system logically connected from various physical machines.
- *Homogeneous network.* A distributed network that requires a specific vendor's proprietary hardware and software. Such networks cannot usually communicate with another vendor's hardware.
- *Heterogeneous network.* A distributed network that can communicate with unrelated hardware by different vendors, usually via de facto protocols and hardware standards.

erating systems should take place.

Also, because of the lack of knowledge about remote clients and servers, NFS remains stateless. You can view this as advantageous, because NFS doesn't need to keep track of past resource requests, such as files opened by clients. Cleaner network traffic results, as well as better network performance, because NFS can perform block read-aheads and block write-behinds. Furthermore, if the network fails, error recovery is much simpler than in RFS. Currently, NFS also supports the concept of a diskless workstation.

Diskless workstations have potential. A typical local-area network could contain many smaller systems, each containing smaller and slower disks. Taking advantage of the hardware on another machine, even to the extent of making a client completely diskless, is smart from the standpoint of economy as well as performance. In the latter case, the diskless workstation might take advantage of an extremely fast and large disk on the server. This scenario would come in handy in a typical database application.

As in RFS, the default situation for NFS is that file systems and files should not be shared. This creates more administrative work and could limit transparency under many networks. For this rea-

son, many servers choose to make their file systems available all the time.

A Feasible Choice

Networks are great for allowing smaller or even diskless workstations access to larger and more efficient resources. These resources usually include accessing remote file-system files, but they can also involve resources such as printers, floppy disks, program spoolers, or program documentation.

Both NFS and RFS are feasible choices for creating a shared Unix workstation environment, and they are capable of coexisting as de facto standards. In fact, with the recent joint ventures between AT&T and Sun Microsystems, NFS and RFS may someday reside on the same machine or network. Notwithstanding this, both are powerful and flexible options. Because of their transparency to users, shell scripts, and programs, they can provide economical networks regardless of hardware vendor constraints. ■

Greg Comeau is CEO of Comeau Computing, an independent software development and consulting firm specializing in Unix, C, and C++ programming tools. He can be reached on BIX as "comeau."

BYTE T-Shirts

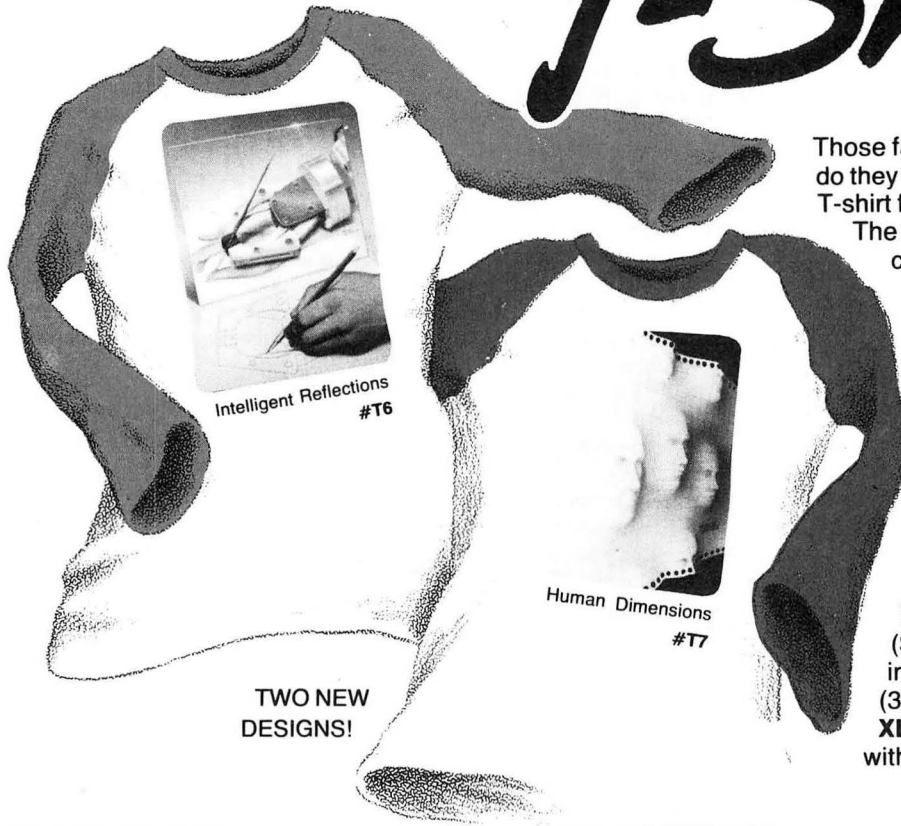

TWO NEW
DESIGNS!

Those fantastic Byte covers—and boy, do they look great on this stylish, ¾ sleeve T-shirt from Robert Tinney Graphics!

The colored sleeves and neckline vividly complement the full-color design.

And don't mistake this for a rubbery patch that cracks and peels off after a few washings. This is true four-color process: the permanent inks are silk-screened into the fabric, resulting in a beautiful, full-color image that lasts!

You'll also appreciate the shirt itself: a heavyweight cotton/polyester blend which combines tough washability with the cool, soft comfort of cotton. Each Byte T-shirt is priced at only \$12.50 (\$11.50 each for 3 or more). Be sure to include shirt size: **C**—(child 10-12), **S**—(34-36), **M**—(38-40), **L**—(42-44), and **XL**—(46-48). Most orders shipped within a week.

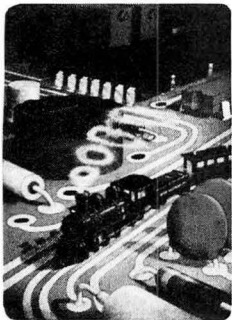

#T1—Computer Engineering

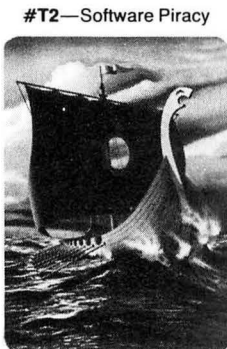

#T2—Software Piracy

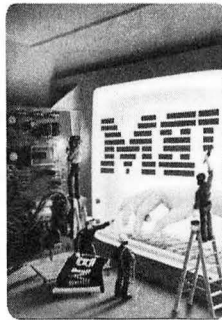

#T3—Inside IBM



#T4—Future Past

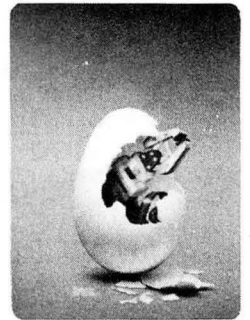

#T5—Breakthrough

Send the following T-shirts(s) at \$12.50 each, or \$11.50 each for 3 or more. I have included \$2 for shipping & handling (\$5 overseas).

QTY.	#	TITLE	SIZE	AMOUNT
				\$
				\$
				\$
				\$
				\$
				\$
				\$
				\$
				\$
				\$
				\$
		Shipping & handling (see above)		\$
		<input type="checkbox"/> Please send your COLOR brochure	TOTAL	\$

- I have enclosed U.S. check or money order.
 C.O.D. (via UPS—stateside orders only)
 VISA MasterCard American Express

Card #: _____

Expires: _____ Signature: _____

Ship my shirt(s) to:

Name: _____

(Business): _____

Address: _____

City: _____

State: _____ Zip: _____

mail this coupon to:

**Robert Tinney
Graphics**

P.O. Box 778
Washington, LA
70589

For VISA, MasterCard or
American Express orders,
or for more information

Call 1-318-826-3003



BYTE

Limited Editions



#G Programmable Hardware \$55

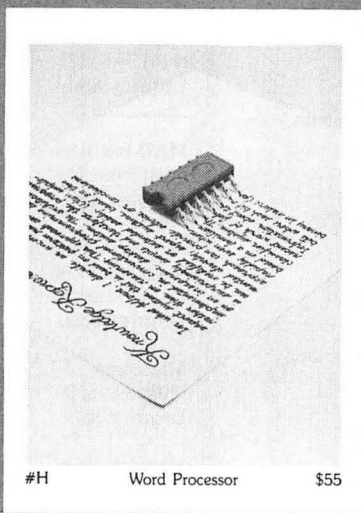

#H Word Processor \$55

You've seen them on the pages of Byte — now enjoy these delightful images as stunning limited edition prints! Each exquisite, 16" x 20" reproduction is part of an edition strictly limited to only 1000 prints. The museum-quality paper is an acid-free, 100% cotton fiber stock (highly resistant to yellowing or cracking) which will preserve image color and brightness for generations.

The artist, Robert Tinney, personally inspects, signs and numbers each individual print. Accompanying the print is a Certificate of Authenticity (also signed and numbered by Tinney) which verifies the number of the edition and the destruction of the press plates.

The price of each print depends on the number of unsold prints in the edition, and is shown beneath the photos at left. If your order exceeds \$100, deduct 15%. All prints are shipped flat via UPS Blue Label, and carry an unconditional 30-day guarantee.

To order, clip the coupon below. VISA, MasterCard or AmEx orders may call 1-318-826-3003.

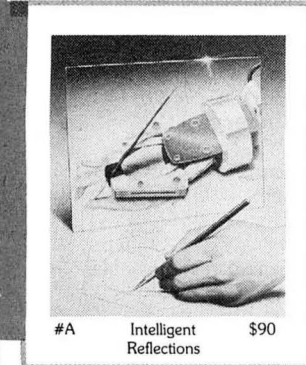

#A Intelligent Reflections \$90

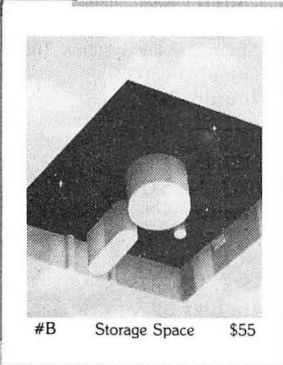

#B Storage Space \$55

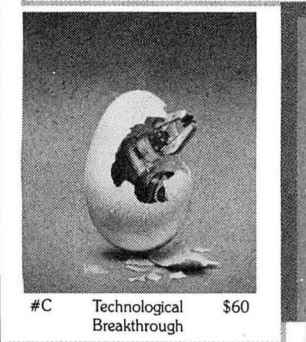

#C Technological Breakthrough \$60

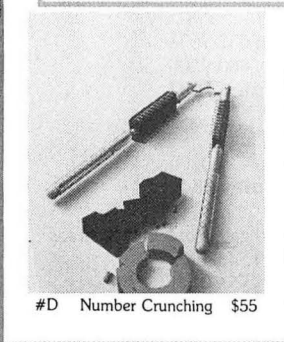

#D Number Crunching \$55

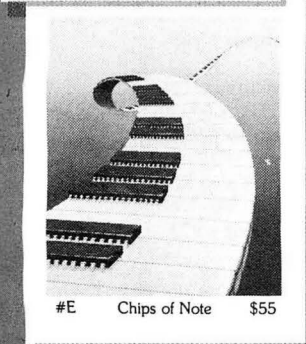

#E Chips of Note \$55

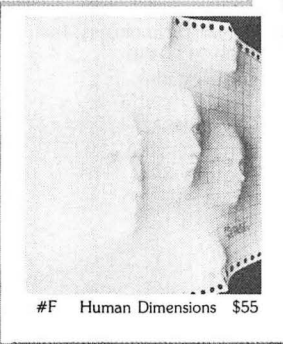

#F Human Dimensions \$55

YES! Send me the following Byte Limited Editions.

QTY.	#	TITLE	AMOUNT
			\$
			\$
			\$
			\$
			\$
			\$
If your order exceeds \$100, deduct 15%.			\$
\$4 postage & handling (\$25 overseas).			\$
TOTAL			\$

- Send a color brochure showing your other prints.
- I have enclosed U.S. check or money order.
- C.O.D. (via UPS—stateside orders only)
- VISA MasterCard American Express

Card #: _____

Expires: _____ Signature: _____

SHIP MY PRINT(S) TO:
 Name: _____
 (Business): _____
 Address: _____
 City: _____
 State: _____ Zip: _____
 Country: _____

Mail this coupon to:

ROBERT TINNEY GRAPHICS
 P.O. Box 778 • Washington, LA 70589

For VISA, MasterCard or American Express orders,
 or for more information
CALL 1-318-826-3003

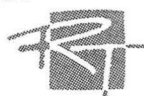

The Players

Acer Counterpoint, Inc.
(408) 434-0190
Inquiry 1015.

Acer Technologies Corp.
(408) 922-0333
Inquiry 1016.

Advanced Logic Research, Inc.
(714) 581-6770
Inquiry 1017.

A.I.C. Computers, Inc.
(416) 492-2777
Inquiry 1018.

Alpha Microsystems
(714) 957-8500
Inquiry 1019.

Altos Computer Systems
(408) 946-6700
Inquiry 1020.

Amdek Corp.
(800) 722-6335
(408) 922-5700
Inquiry 861.

American Mitac Corp.
(408) 432-1160
Inquiry 862.

Apollo Computer, Inc.
(508) 256-6600
Inquiry 863.

Apple Computer, Inc.
(408) 996-1010
Inquiry 992.

AST Research, Inc.
(714) 863-1333
Inquiry 1000.

AT&T Information Systems
(800) 247-1212
Inquiry 863.

Becterm
(418) 835-1551
Inquiry 864.

Compusource International
Corp.
(305) 251-1188
Inquiry 865.

Computer Systems
(313) 779-8700
Inquiry 866.

Datamedia Corp.
(603) 886-1570
Inquiry 867.

Dell Computer Corp.
(512) 338-4400
Inquiry 868.

DEST Corp. Florida
(407) 994-3720
Inquiry 869.

Digital Electronic Systems
(305) 572-3338
Inquiry 870.

Digital Equipment Corp.
(508) 897-5111
Inquiry 871.

Elco
(818) 284-3281
Inquiry 872.

Everex Systems, Inc.
(415) 498-1111
Inquiry 873.

Fortron Corp.
(408) 432-1191
Inquiry 874.

Franklin Telecom
(805) 373-8688
Inquiry 875.

Gulfstream Micro Systems,
Inc.
(DEST Corp. Florida)
(407) 994-3720
Inquiry 876.

Hertz Computer Corp.
(212) 684-4141
Inquiry 877.

Hewlett-Packard
(415) 857-1501
Inquiry 878.

Honeywell Bull
(617) 895-6000
Inquiry 879.

IBM Corp.
(914) 765-1900
Inquiry 880.

Icon International, Inc.
(801) 225-6888
Inquiry 881.

IndTech, Inc.
(408) 743-4300
Inquiry 882.

Kowin Computer Corp.
(213) 721-5500
Inquiry 883.

Logic Process Corp.
(214) 340-5172
Inquiry 884.

MAD Intelligent Systems, Inc.
(408) 943-1711
Inquiry 885.

MAI Basic Four, Inc.
(800) 854-3194
(714) 731-5100
Inquiry 886.

Masscomp
(508) 692-6200
Inquiry 887.

Megadata Corp.
(516) 589-6800
Inquiry 888.

Micro Display Systems, Inc.
(408) 743-4300
Inquiry 889.

NBI, Inc.
(303) 444-5710
Inquiry 890.

NCR Corp.
(513) 445-7478
Inquiry 891.

NEC Home Electronics (USA),
Inc.
(800) 632-7638
(312) 860-9500
Inquiry 1007.

NeXT, Inc.
(415) 424-0200
Inquiry 984.

Northgate Computer Systems
(800) 548-1993
(612) 553-0111
Inquiry 892.

Ogivar Technologies, Inc.
(514) 737-3340
Inquiry 893.

Olivetti USA
(201) 526-8200
Inquiry 894.

Pindar Computer Corp.
(703) 790-0555
Inquiry 895.

Profit Technology
(800) 223-4628
(212) 809-3500
Inquiry 896.

Rexon Business Machines
Corp.
(213) 641-7110
Inquiry 897.

SCI/Fortune Systems Corp.
(415) 593-9000
Inquiry 898.

SCI Systems, Inc.
(205) 882-4800
Inquiry 899.

Silicon Graphics, Inc.
(415) 960-1980
Inquiry 985.

Sophos Integrated Systems
(301) 292-5585
Inquiry 900.

Spectrix Microsystems, Inc.
(416) 474-1955
Inquiry 966.

Sun Microsystems, Inc.
(415) 960-1330
Inquiry 986.

Symbolics, Inc.
(617) 221-1000
(617) 621-7500
Inquiry 967.

Tandem Computers, Inc.
(408) 725-6000
Inquiry 968.

Tandon Computer Corp.
(805) 523-0340
Inquiry 1049.

Tandy Corp.
(817) 390-3011
Inquiry 969.

Tektronix, Inc.
(503) 627-7111
Inquiry 970.

TeleVideo Systems, Inc.
(408) 745-7760
Inquiry 971.

Texas Instruments, Inc.
(800) 527-3500
(214) 995-2011
Inquiry 972.

Third Coast Technologies, Inc.
(414) 272-4220
Inquiry 973.

Unisys Corp.
(313) 972-7000
Inquiry 974.

Unitronix Corp.
(800) 257-7482
(201) 981-1600
Inquiry 975.

VG Systems, Inc.
(818) 346-3410
Inquiry 976.

Wang Laboratories, Inc.
(508) 459-5000
Inquiry 977.

Workstations Products
and Services
(212) 685-6996
Inquiry 978.

WYSE Technology
(408) 433-1000
Inquiry 979.

Xerox Corp.
(800) 832-6979
Inquiry 980.

Xmark Corp.
(714) 556-9210
Inquiry 1046.

XYZTEK Corp.
(303) 850-9400
Inquiry 1047.

Zenith Data Systems
(800) 842-9000
(312) 699-4800
Inquiry 1048.

BBS SYSOPS

Are you looking for ways to improve your board? Something that will set you apart from the other boards in your area?

Are your subscribers interested in Microcomputers? Listen to this!

Announcing the Bulletin Board EXchange — BBX

The BBX allows you to become a publisher of MicroBYTES Daily, an on-line news service from BYTE. BBX/MicroBYTES is a custom package of news and features designed specially for local BBSes, and is available only to sysops.

Every Monday through Friday you get articles about developments in microcomputing, telecommunications and selected new product announcements. Get the latest news MSDOS machines, Macintosh, Unix workstations, peripherals and software. All the stories are reported, written and edited by the staff of BYTE Magazine, BYTEweek and BIX. With BBX/MicroBYTES your board will have access to our world-wide network of reporters and editors.

Not only do you get a great resource for your subscribers, but you also get access to BIX which will cut your cost of exchanging information and conducting BBS network business.

All this is only \$199 per year. If you call BIX directly you pay no hourly rates. If you call using Tymnet the rates are only \$2/hr on evenings and weekends and \$8/hr on weekdays.

Subscribe today.

BIX

One Phoenix Mill Lane, Peterborough, NH 03458
1-800-227-2983 ♦ In NH (603) 924-7681

We make a super VGA monitor



NEC introduces the best VGA monitor you can buy. MultiSync® 2A.

The first monitor that takes our award-winning multiple frequency technology and cus-

tomizes it to the needs of the VGA user.

MultiSync 2A is both affordable and uncompromised. And completely compatible with all VGA modes. In short, it performs brilliantly. But what's equally important, it allows you to move effortlessly to the next major graphics standard: SuperVGA.

All this in a monitor that gives you a 14" non-glare screen on a tilt-swivel base, for nearly 30% more viewing area than standard 12" screens, and a new cabinet that's not only functional but is designed to look as good from the back as it does from the front.

MultiSync 2A. One super VGA monitor.

VGA mode shown at 320 X 200



Computers and Communications

that's also a SuperVGA monitor.



But that's only part of the story. NEC also introduces the best SuperVGA monitor you can buy. MultiSync® 2A.

The first monitor that takes our award-winning multiple frequency technology and customizes it to the needs of the SuperVGA user. MultiSync 2A senses the software you're using and makes the switch from a VGA monitor to SuperVGA, the new standard developed by NEC and recognized by VESA, the Video Electronics Standards Association. SuperVGA delivers a maximum resolution of 800 x 600, which is 56% higher than VGA.

And since you're most likely buying a board that goes beyond VGA, your monitor should too. For literature call 1-800-826-2255. For technical details call NEC Home Electronics (USA) Inc. at 1-800-FONE-NEC.

MultiSync is a registered trademark of NEC Home Electronics (USA) Inc.

MultiSync 2A. One SuperVGA monitor.

© 1989 NEC Home Electronics (USA) Inc.

NEC

DIGITAL PAPER

A new breed of write-once optical media that can store up to a gigabyte of data on floppy disk-size cartridges with hard disk speeds

Dick Pountain

Three or four years ago, during the first euphoria that accompanies a new technology, it was widely predicted that optical storage media with gigabyte capacities would soon oust magnetic storage from the computer industry. Now that the dust has settled and various optical products are being shipped, things look rather different. It seems more likely that optical storage devices will coexist with magnetic for some time to come, having found a niche as a medium for long-term archival storage and backup, while magnetic hard disks remain the preferred form of temporary working storage.

You can divide optical storage devices into three categories, according to the permanence of the data they store: read-only media; WORM (write once, read many times) media; and read-write-erase media. The categories of media differ in the precise way they write and read the stream of digital "dots" that have been written onto the media.

Like phonograph records, read-only media such as audio compact disks (CD) and computer CD-ROM disks have to be prerecorded. They serve only as a means of distribution for large volumes of data; you can neither write to the disks nor erase the data they contain. With capacities of 500 to 600 megabytes, they can carry huge databases equivalent to a whole shelf of books (like Microsoft's Bookshelf) or hours of digitized sound.

WORM media, which are finding increasing favor as archival storage devices, can be written with data once but never erased. Since the typical capacity of a WORM disk cartridge is 200 to 300 megabytes, a single disk can hold weeks' or months' worth of data. When the disk fills, you just start a new one. For many applications, such as legal work or accounting, the existence of this unerasable "audit trail" is an advantage.

Finally, there is the full read-write-erase optical disk, long available in research labs but only now emerging commercially in Steve Jobs's NeXT computer (strictly speaking, the NeXT disk is magneto-optical, because it combines magnetic and optical technologies). In principle, such a disk can completely re-

place a magnetic hard disk, as it does in the NeXT, though at present, the retrieval performance is considerably slower than the best hard disks.

The latest optical technology is digital paper, a write-once optical storage medium. However, digital paper differs from existing WORM media in that it is flexible and can be produced in large sheets and reels (hence the fanciful name). As a result, it can be cut, stamped, and otherwise built into a variety of products, including floppy Bernoulli disks, tapes, and credit cards. It promises to make smaller, faster, and cheaper WORM drives as available as floppy disk drives are today.

Digital paper was developed by a British company called Imagedata. Imagedata's parent company, Imperial Chemical Industries, is one of the world's largest chemical combines. As such, ICI has special expertise in polymer films and dyestuffs, both of which were crucial in the development of digital paper.

Principles of Optical Media

To understand how digital paper works, you first have to understand the basic principles of optical data storage. I'll briefly recap the main ideas here, but you can find a fuller explanation in the November 1985 BYTE article "CD-ROMs and Their Kin" by Richard S. Shuford.

All the various existing optical storage systems have this much in common: To operate, they use the modulation of a beam of laser light by reflection from a thin mirror-like layer of metal applied to a transparent plastic substrate. By one means or another, they all write a stream of digital dots onto this mirror layer. These dots can be read back by moving them under a laser beam and measuring the intensity of the reflected beam.

It's not the absolute intensity of the reflected beam that's significant, but the transition between two different intensity levels. The data rate you can achieve is determined by the reading mechanism's ability to discriminate such "edges." It is the interval or mark/space ratio between edges that is used to encode digital data—hence, each dot may encode more than one

continued

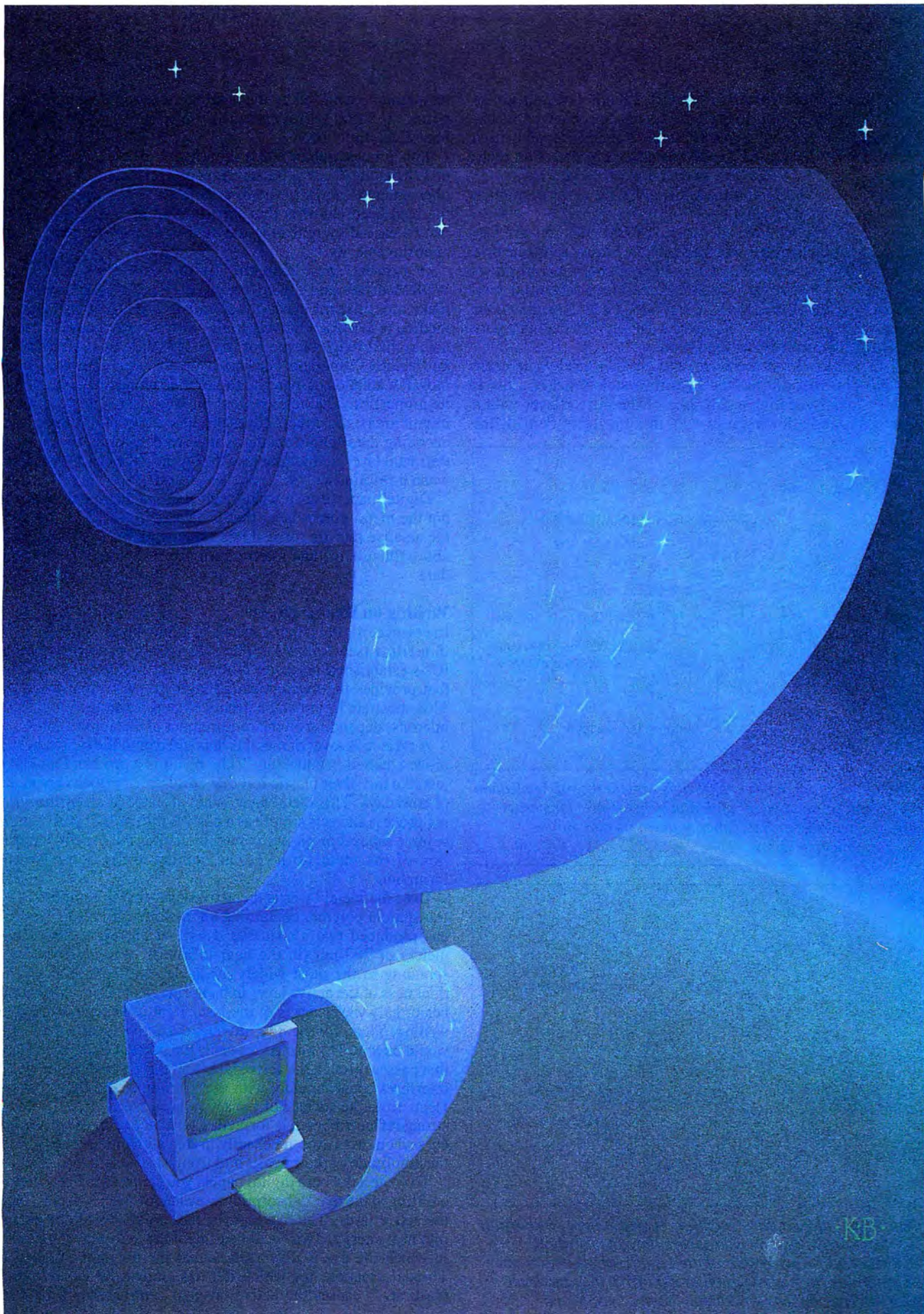

bit of information (typically around 1.5 bits). The dots are so tiny that enormous information density can be achieved. Packing the dots so densely, however, leads to an unacceptably high raw-error rate, requiring sophisticated error-correction techniques. On optical disks, anywhere between 10 percent and 33 percent of the stored information might be error-correction code rather than user data.

In a read-only medium such as CD-ROM, the dots are tiny pits that are mechanically formed into the plastic substrate by a stamping process—just like the old phonograph-record-pressing process. A mirror layer of aluminum is then vacuum-deposited over the pits. When the disk is rotated under a reading laser beam, the edges of these pits cause a step in reflected intensity that can be detected by the read head.

At the other end of the scale, the NeXT's read-write-erase disk has dots that are formed by a reversible process. This is done by locally heating a tiny area of the mirror layer with a laser beam and allowing it to cool in a magnetic field. If the

temperature achieved by the heating exceeds the metal's Curie point, the metal will recrystallize in alignment with the magnetic field direction.

This process subtly alters the surface properties of the area and shifts the angle of polarization of a reflected laser beam (a phenomenon known as the Kerr Effect). A polarizing filter in the read head converts this shift into an intensity step. A dot can be erased by reheating the area in a magnetic field of the opposite polarity.

In between these extremes lie the write-once media like WORM drives and digital paper, in which a laser is used to make a permanent mark on the mirror layer. The most direct method is to use a relatively high-powered laser beam to melt a hole right through the mirror layer. This process is often called an "ablative" method because it involves the irreversible removal or ablation of material rather than merely an alteration of its properties. The holes reflect far less laser light than intact mirror areas; thus, their edges produce a transition suitable for encoding data. Other methods involve deforming or bubbling the metal layer, or melting it so the layer's reflectivity is altered when it resolidifies.

Digital paper uses a write-once ablative technique, but it is not the metal mirror layer that is ablated in this case. Instead, the ablative pits are formed in a transparent layer immediately above the mirror, and interference effects are used to read the data.

Writing on Digital Paper

In essence, digital paper consists of a four-layer "sandwich" of thin films (see figure 1). The substrate is made from one of ICI's established polyester films, called Melinex—a material that provides the mechanical strength of the whole structure. This substrate layer can be produced in thicknesses of 25 to 75 microns, depending on the requirement of the application.

A reflective layer of metal is deposited onto the substrate by a process called "sputtering." The result is a product that looks just like the silver plastic foil that children's balloons are made of nowadays. This metal layer is not affected at all by the writing process and acts simply as a passive mirror. ICI still regards several aspects of digital paper, including the exact composition of the metallic layer, as commercially sensitive information.

Over the metal layer is the active layer that is composed of a transparent polymer containing an infrared-absorbing dye. ICI has produced two alternative dyes that absorb at 830 nanometers or 780 nm (in the near-infrared), wavelengths corresponding to the most widely available solid-state lasers. The thickness of the active layer in its normal state is an exact number of half-wavelengths of the laser light used for reading and writing. Thus, for the 830-nm dye, the active layer's thickness would be $n \times 415$ nm. As a result, the portion of incident light that passes through the active layer and is reflected by the metal interferes constructively with that portion of the light that reflects from the surface of the active layer (see figure 2), and a strong reflected beam is formed. Constructive interference occurs when two waves are exactly in step with one another so that the amplitude of their peaks and troughs is added together.

To write a dot onto digital paper, you beam an infrared laser, emitting at the dye's absorption wavelength (say, 830 nm), onto the active layer. The dye absorbs the radiation and converts it into heat energy. This local heating of the active layer polymer in which the dye is dispersed causes the polymer to deform. The deformation, for which ICI has coined the name "pyroplasticity," causes the active layer to contract into a pit sur-

continued

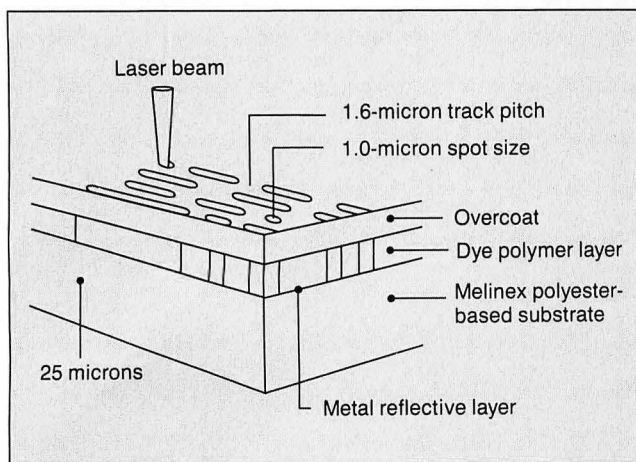

Figure 1: Digital paper is a flexible optical recording medium made from a "sandwich" of thin polymer films. This cross section shows the various functional layers and the approximate dimensions.

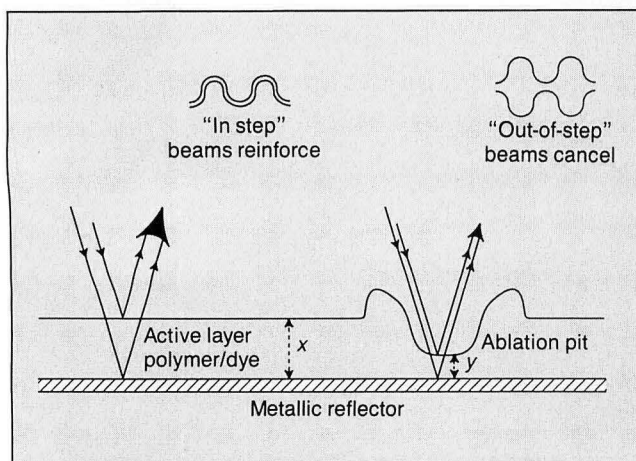
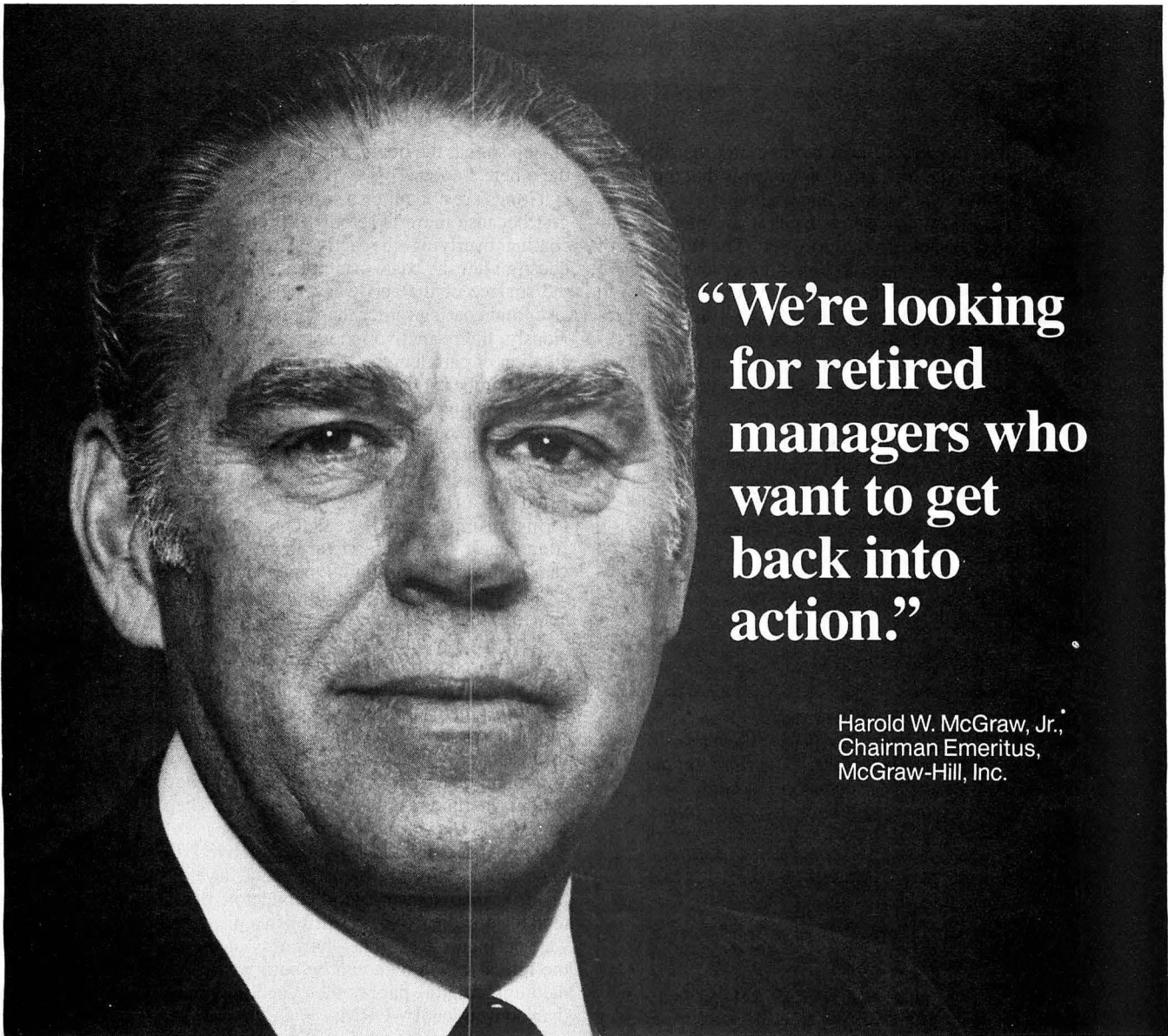

Figure 2: Optical data is encoded on digital paper by burning pits in the active dye/polymer layer. Here, x is a whole number of half-wavelengths of the laser light, while y is not. The pits alter the path length that light from the read laser must traverse, thereby weakening the reflected beam.



**“We’re looking
for retired
managers who
want to get
back into
action.”**

Harold W. McGraw, Jr.,
Chairman Emeritus,
McGraw-Hill, Inc.

I'm a volunteer supporter of the International Executive Service Corps, a not-for-profit organization with a vital mission:

We send retired U.S. managers overseas to help businesses in developing countries, which often respond by increasing their imports of U.S. goods. In fact, developing countries consume about 40 percent of U.S. exports.

As an IESC volunteer, you would not get a salary. But you would get expenses for you and your spouse, plus a world of personal satisfaction.



IESC leads the field in this kind of work. We've done over 9,000 projects in 81 countries. We could have a project that's just right for you.

For more information, send this coupon to: Harold W. McGraw, Jr., Chairman, McGraw-Hill, Inc., P.O. Box 10005, Stamford, CT 06904-2005.

Dear Mr. McGraw: Tell me more about becoming an IESC volunteer. I am a recently retired manager or technician—or am about to retire—from a U.S. company. I'm free to accept an overseas assignment. I understand that volunteers receive expenses for themselves and their spouses, but no salary.

Name _____

Address _____

City _____ State _____ Zip _____

In what publication did you see this ad? _____ M3



International Executive Service Corps

It's not just doing good. It's doing good business.

rounded by a raised lip rather like a moon crater, as shown in figure 2. The result of the formation of this pit is that the thickness of the active layer is reduced at that point.

To read the pit, the same laser is used at an intensity low enough that it does not deform the polymer. The thickness of the active layer at the pit is now no longer an exact number of half-wavelengths. Therefore, the beam that passes through to the metal layer will interfere destructively with the beam reflected from the surface of the active layer—thus, the total reflected beam intensity will be lower than for an undeformed area. Destructive interference occurs when two waves are out

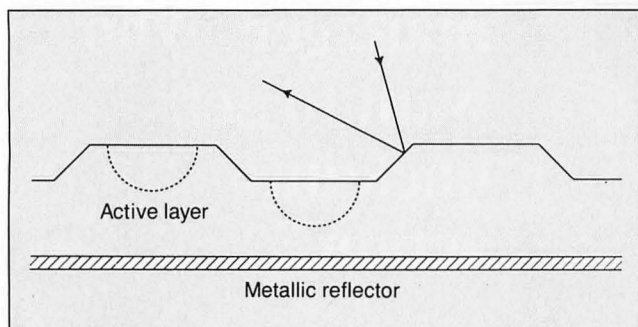

Figure 3: To enable the read laser to track accurately, digital paper must be preformatted, which is done by embossing grooves into the active layer. The flanks of these grooves deflect the straying laser beam and so cause a detectable error signal that is fed back in a servo loop to realign the beam.

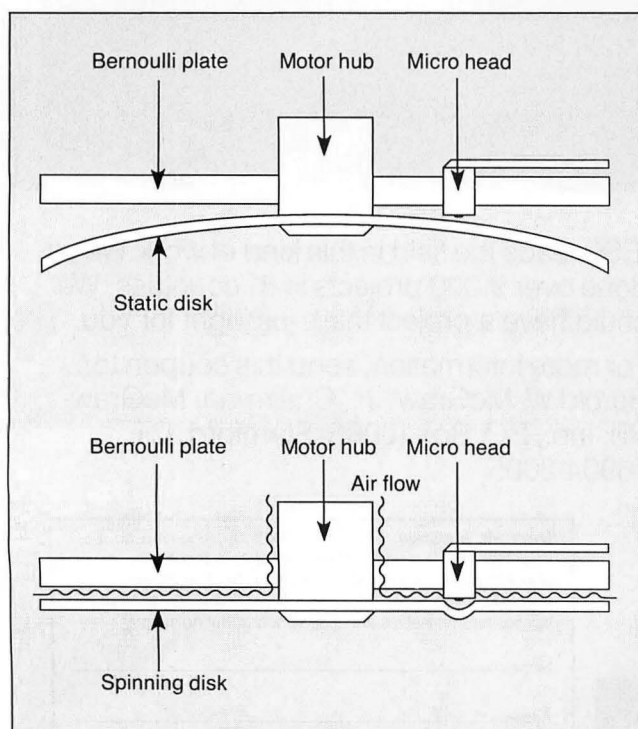

Figure 4: The Bernoulli effect produces lift when air flows faster over the upper surface of the disk than under it. The lift makes the disk "fly" at a close and constant distance from the Bernoulli plate and record head, a feature that is very advantageous for optical recording.

of step so that the peaks and troughs of one cancel out those of the other.

Things are not quite so simple as this description would suggest because there is a fourth, protective layer of transparent coating overlying the active layer. However, this situation doesn't alter the basic principles. The difference is simply that the surface of the active layer is an interface between active layer and coating rather than between active layer and air. Obviously, the refractive index of the coating comes into the calculation of path lengths, and the protective layer needs to be a whole number of half-waves thick.

There is, in fact, a fifth layer on the commercial digital paper product, though it plays no part in the optical storage process. The substrate receives a coat of low-friction polymer as a backing to allow it to slip smoothly when coiled in reels of tape or fitted into a floppy disk cartridge case. This backing layer also forms an impermeable seal to prevent oxygen and moisture from penetrating to the metal layer. ICI currently claims a 15-year archival life for digital paper, but soon, by improving materials and fabrication techniques, the company hopes to be able to extend this time frame to 20 years.

What are the advantages of this pyroplastic method of writing compared to conventional WORM technologies? The main ones are that if you use a lower-powered laser, pits can be written with greater precision. The dye-containing polymer used for the active layer is a very poor conductor of heat. As a result, the heat energy introduced by the laser beam can be confined to a very small volume of material and thus does not spread rapidly. This method results in a pit with very steep, sharply defined edges.

By contrast, the most popular ablative WORM technologies make marks directly onto the metal layer. Since they heat a material that is a very good conductor, the heating effect will tend to spread further, resulting in a pit with more sloping, less well-defined edges. The sharpness of the transitions governs the rate at which data can be both written to and read from a medium. Digital paper, then, can support higher data rates than conventional WORMs.

The low thermal conductivity also helps to reduce the laser power needed to produce a pit. A more important influence, though, is the thickness of the overlying layers. In a rigid WORM disk, the metal reflector layer is covered with a polycarbonate plastic that is typically 1 mm or more thick. The dimensional accuracy is such that the writing head needs to be another millimeter or so from the disk surface. Thus, the distance the laser light must travel to get to the metal reflective layer, 2 mm, is huge compared to the size of a pit. Large losses occur due to absorption and scattering in the plastic.

On the other hand, with digital paper, the overlying protective layer is less than a micron thick, so less laser power is required to traverse it. As we shall see later on, other factors also allow a reduction in the gap between the laser and the surface. A 10-milliwatt solid-state laser can write on digital paper at rates of up to 10 MHz, forming pits that are 1 micrometer deep.

For most computer applications, digital paper will be preformatted at the manufacturing stage with information that tells the drive mechanism where to write the pits that encode the data and that allows the laser head to track the data accurately. Mechanical ridges and grooves are embossed into the surface of the active layer (see figure 3) to achieve this result. These ridges deflect the laser beam from their sloping surfaces if it should stray too far from the data pits. This deflection produces a strong transition, which the drive mechanism can use in a servo loop to restore the head to its correct track. Pits can be written either in the valleys or on the flat tops of the ridges. The

drive manufacturer makes the design decision that results in the choice of position.

Digital Paper and the Bernoulli Effect

The most promising development of digital paper for personal computer users is the one that's taking place at Bernoulli Optical Systems Corp. (BOSCO for short). BOSCO is a subsidiary of IOMega Corp., well known for its Bernoulli Box series of magnetic disk drives. The firm is developing a product that combines Bernoulli technology with digital paper.

The biggest
advantage of digital paper, by far,
is its mechanical flexibility.

The marriage of these two technologies is a natural one. It is a good example of synergy because the biggest advantage of digital paper, by far, is its mechanical flexibility. This feature allows us to use digital paper for flexible disks, a process that so far none of the competing technologies can imitate. By making digital paper into flexible disks, BOSCO is exploiting its existing Bernoulli expertise to produce a high-performance optical disk cartridge drive.

Bernoulli's principle states that when the fluid flow is faster on one side of an object than on the other, the object feels a force toward the faster flow. It's this effect that allows an airplane's wings to lift it into the sky and the draft from a window to lift your papers from your desk.

The Bernoulli Box achieves this effect by using a flexible magnetic disk that rotates very close to the underside of a fixed circular plate containing the record heads (the removable disk is contained in a rigid protective cartridge like that of a 3½-inch floppy disk). As the disk spins, the Bernoulli plate channels and accelerates an airflow drawn in from perforations near the hub toward the perimeter. This process causes a net lift on the flexible disk, which is drawn toward the fixed plate and settles nearby, separated by a cushion of moving air. The head-to-disk spacing is about 50 microns. The effect can even allow the disk to mold itself around irregularities and protrusions like the record head (see figure 4).

The Bernoulli disk is well suited for many applications, because head crashes are much less likely than with a hard disk drive. It is virtually impossible for the record head to touch the disk surface, since any major obstruction, shock, or power failure will destroy the pressure gradient and cause the floppy disk to fall momentarily away from the head.

An added attraction of Bernoulli technology for optical drives is that it maintains the very small head-to-disk spacing accurately without any complex servo mechanism. Therefore, the biggest headache for the designer of an optical read/write head (namely, the problem of how to keep the laser beam focused on the reflective layer of the disk) disappears completely.

In CD and WORM drives, the head-to-disk spacing can vary widely enough to defocus the laser spot, resulting in insufficient energy being delivered to write pits, or a reduction in the accuracy of reading. To combat this effect, all the manufac-

continued

INTRODUCING BYTE's Direct Response International Postcards

From the most prestigious microcomputer magazine comes a new and inexpensive direct response medium—a postcard advertising insert bound into the highly respected International Section of BYTE Magazine, called *BYTE's International Direct Response Postcards*.

Postcard ads provide a direct-response vehicle that encourages prospects to respond to offers for information as well as direct sales. A postcard ad is versatile because it allows you to test your product to potential buyers. That's because you can use your card to sell computer products, generate leads, conduct market research or sell books and periodicals. Each postcard is perforated so it can be easily torn out and returned directly to you without any intermediary—guaranteeing leads that are current and "hot."

*Expand your horizons
into this valuable marketplace.*

The Pan-European marketplace is preparing to open up to greatly expanded trade in 1992 with the breaking down of trade restrictions. And *BYTE's International Direct Response Postcards* presents the perfect opportunity to test your product in this marketplace and to get your company positioned in the minds of the major buyers.

These unique advertising postcards which will be inserted into the International Section will reach 70,000 influential BYTE paid readers throughout Europe.

In Europe, contact:

Karen Lennie or

Roz Weyman (German-speaking)

at (01) 493-1451

McGraw-Hill Publications

34 Dover Street

London W1X 4BR

England

For More Information

ICI Imagedata
P.O. Box 6, Shire Park
Bessemer Rd.
Welwyn Garden City
Hertfordshire AL7 1HD, U.K.
(0707) 337284

Bernoulli Optical Systems Corp. (BOSCO)
5700 Flatiron Pkwy.
Boulder, CO 80301
(303) 939-8611

Creo Products, Inc.
110 Discovery Park
3700 Gilmore Way
Burnaby, BC Canada V5G 4M1
(604) 437-6879

turers of ordinary WORM drives use an active focusing mechanism with a lens mounted on voice coil that can move up and down to alter the point of focus. This coil forms part of a closed-loop servo mechanism driven by error signals from the photodetector output to keep the spot at a constant size. The whole lens and voice coil mechanism has to track with the laser head, adding to the moving mass of the system.

Another factor that takes mass away from the head in the Bernoulli drive is that it can dispense with the fine tracking adjustment mechanism based on tilting mirrors required by other optical drives to compensate for minor wobbling. The Bernoulli drive can track the data pits using a simple servo mechanism based on the embossed grooves mentioned above. The BOSCO drive can get away with a simple head containing just a fixed-focus lens, free from all this complex active focusing and tracking machinery. A light head is easier to move around, and, thus, track-to-track seek times can be speeded up.

The close spacing produced by the Bernoulli effect also reduces the total distance that the laser light has to travel. Compared to a conventional WORM drive, this reduced distance allows the lens to be of a larger numerical aperture and hence deliver more laser power to the active layer. More energy creates a pit faster and lets the drive sustain a faster data rate. This feature permits the disk to be rotated faster, since you can write more pits in a given time frame and improve the latency time when reading (i.e., the time taken for the required sector to come around under the head). Better seek time and latency mean a faster drive.

The third beneficial effect of the Bernoulli technology is that the laser heads are so small that two of them can fit into a half-height disk drive housing, which permits the design of a truly double-sided drive. Conventional WORM disks are sometimes double-sided, but the drives have only one head, so you have to manually turn the disk over to use the other side. The double-sided Bernoulli disk cartridges contain two disks separated by a small gap, with their active surfaces facing outward. The upper disk then acts as the Bernoulli plate for the lower disk.

The result is that the BOSCO drive promises an on-line capacity of 1 gigabyte of data per 5¼-inch cartridge disk, with an average seek time of 40 ms, which is as fast as a modest hard disk drive and much faster than conventional WORM drives. The disk

rotates at 1800 revolutions per minute, compared to around 500 rpm for typical WORM drives. The data transfer rate tells the story even better, as the BOSCO disk can transfer 1.5 megabytes per second compared to 0.25 megabyte per second for IBM's WORM drive or 0.16 megabyte per second for the ISI 525 WC WORM drive. BOSCO expects to bring the new drive to market at about the same price as a single-head WORM drive and the media at about the same price as a single-sided WORM disk.

Although BOSCO is wholly owned by IOMega, the firm was set up with the aid of ICI Imagedata to develop digital paper technology, and ICI retains the right to license the drive technology to other disk manufacturers.

Reeling in the Bits

Although the Bernoulli drive may be of the greatest immediate interest to PC users, the first commercially available product based on digital paper will be a tape system designed by Creo Products, Inc., of Vancouver, British Columbia. One 12-inch reel of this 35-mm-wide digital paper tape can store 1 terabyte (1000 gigabytes) of data. To help you grasp how much storage this is: within 1 terabyte, you could store 1 billion typed sheets of paper, the contents of 1600 compact disks or 5000 conventional magnetic tape cartridges, at a cost of around a half a cent per megabyte. This tape system is designed for mainframe applications where huge volumes need to be stored, such as in seismic data logging, satellite image-processing applications, and medical imaging and document archiving.

The Creo 1003 Optical Tape Drive uses a small-computer-system interface (SCSI) and can sustain a data transfer rate of 3 megabytes per second. It takes an average of 28 seconds to select any single byte from a full 1-terabyte tape. The drive uses a novel method of recording, in which 32 LED laser recording heads scan across the width of the tape from left to right, then from right to left in discrete chunks, rather like the frames of a photographic film. Each "frame" or physical record is 32 bits wide by 20,000 bits and holds 80K bytes of data. The first drives are due to be delivered in mid-1989 to the Canadian Department of National Defense and the Center for Remote Sensing.

It's not hard to imagine other possible applications for digital paper. One device that ICI Imagedata wants to see designed is a 2-inch optical disk drive for use in portable computers and digital cameras. Even at today's densities, such a disk could hold 80 to 100 megabytes per side, and this density should increase as solid-state laser technology improves. Other potentially fruitful areas are that of credit card-size memory devices and smart tags and labels.

Digital paper also shows promise as a low-cost, read-only medium for distributing specialized databases in small volumes without incurring the huge preparation and tooling costs involved in CD-ROM manufacture. You could duplicate them to order just as small software houses do now with floppy disks.

Erasable optical drives, heralded by the NeXT machine, are set to invade the market. Even so, there is still an important role for a nonerasable archival storage medium like digital paper—at the very least, to replace slow and unreliable magnetic tape drives for backing up hard disks. I calculate that everything I have written, programmed, or otherwise generated during my working life would fit comfortably onto a single 1-gigabyte Bernoulli disk. ■

Dick Pountain is a BYTE contributing editor, a technical author, and a software consultant living in London, England. You can contact him on BIX as "dickp."

3 books for only \$1.95

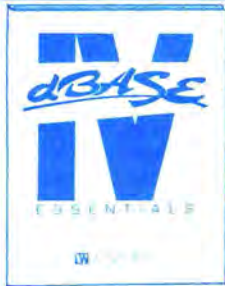

and get FREE!
dBASE IV™ Essentials

YES! Please accept my membership in the *Computer Professionals' Book Society* and send me the volumes I have listed below, plus my free copy of dBASE IV Essentials (3116P), billing me only \$1.95 plus shipping and handling charges. I understand that the books are sent on a 10-Day Free

Examination basis. If dissatisfied in any way, I may return the books within 10 days and incur no further obligation. Otherwise, I agree to pay the enclosed invoice promptly and to receive regular club bulletins as described in "How the Club Works." To complete my membership obligation I need only purchase 3 additional books at regular members prices during the next 2 years, and may resign at any time thereafter.

NAME _____

NAME OF FIRM _____
(If you want Society Bulletins sent to your office)

ADDRESS _____

CITY _____ STATE _____ ZIP _____

SIGNATURE _____

Valid for new members only. Foreign applicants will receive special ordering instructions. Canada *must* remit in U.S. funds. This order is subject to acceptance by the *Computer Professionals' Book Society*. BYP-289



3 books for only \$1.95



and get FREE!
dBASE IV™ Essentials

YES! Please accept my membership in the *Computer Professionals' Book Society* and send me the volumes I have listed below, plus my free copy of dBASE IV Essentials (3116P), billing me only \$1.95 plus shipping and handling charges. I understand that the books are sent on a 10-Day Free

Examination basis. If dissatisfied in any way, I may return the books within 10 days and incur no further obligation. Otherwise, I agree to pay the enclosed invoice promptly and to receive regular club bulletins as described in "How the Club Works." To complete my membership obligation I need only purchase 3 additional books at regular members prices during the next 2 years, and may resign at any time thereafter.

NAME _____

NAME OF FIRM _____
(If you want Society Bulletins sent to your office)

ADDRESS _____

CITY _____ STATE _____ ZIP _____

SIGNATURE _____

Valid for new members only. Foreign applicants will receive special ordering instructions. Canada *must* remit in U.S. funds. This order is subject to acceptance by the *Computer Professionals' Book Society*. BYP-289



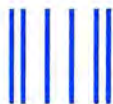

NO POSTAGE
NECESSARY
IF MAILED
IN THE
UNITED STATES

BUSINESS REPLY MAIL

FIRST CLASS PERMIT NO. 9 BLUE RIDGE SUMMIT, PA 17214

POSTAGE WILL BE PAID BY ADDRESSEE

Computer Professionals'
Book Society
Blue Ridge Summit, PA 17214-9988



NO POSTAGE
NECESSARY
IF MAILED
IN THE
UNITED STATES

BUSINESS REPLY MAIL

FIRST CLASS PERMIT NO. 9 BLUE RIDGE SUMMIT, PA 17214

POSTAGE WILL BE PAID BY ADDRESSEE

Computer Professionals'
Book Society
Blue Ridge Summit, PA 17214-9988



THE COMPUTER PROFESSIONALS' BOOK SOCIETY

The easy, reliable way to satisfy your professional book needs . . .

3 books for only \$1⁹⁵ (Values to \$158.80)

and get **dBASE IV™ Essentials** FREE!



3019 \$39.95
Counts as 2

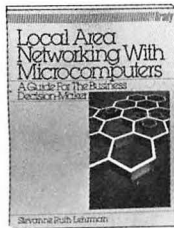

9763P \$19.95

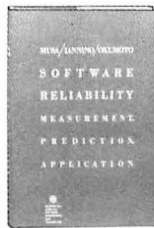

9824 \$49.95



9779P \$22.95



2838 \$19.95



3028 \$27.95

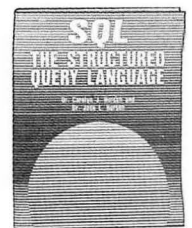

3016P \$16.95



2937 \$29.95

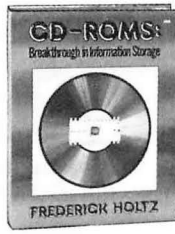

3026 \$22.95



2741P \$19.95

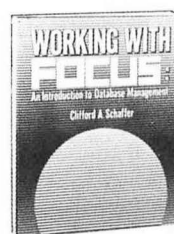

2810P \$22.95

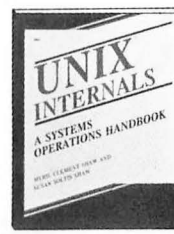

2951P \$17.95



2870 \$24.95



2959P \$19.95



2740 \$34.50



2897 \$27.95



2845 \$29.95



2763 \$27.50



9764P \$19.95



9832 \$36.95

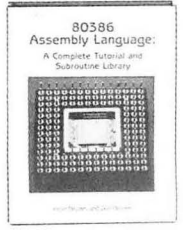

3047 \$34.95



9786 \$32.95

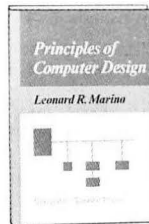

9813 \$39.95



2956 \$32.95

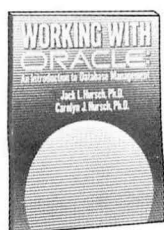

2916P \$19.95

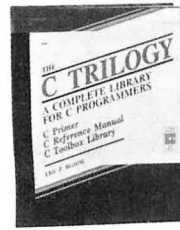

2890 \$32.95



9808 \$34.95

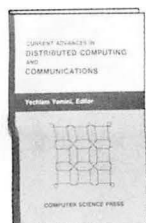

9777 \$49.95

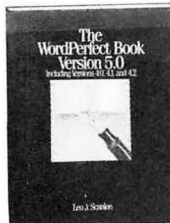

3127P \$16.95



2888 \$28.95

FREE when you join the

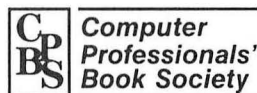

dBASE IV™ Essentials

A unique and timely discussion of all the new programming features offered by dBASE IV™ —including both SQL and QBE.



How the Club Works

YOUR BENEFITS: You get 3 books for \$1.95 plus shipping & handling when you join. You keep on saving with discounts up to 50% as a member.

YOUR PROFESSIONAL BOOKSTORE BY MAIL: Every 3-4 weeks, you will receive the Computer Professionals' Book Society News describing the Main Selection and Alternates, as well as bonus offers and special sales, with hundreds of titles to choose from.

AUTOMATIC ORDER: If you want the Main selection, do nothing and it will be sent to you automatically. If you prefer another selection, or no selection at all, simply indicate your choice on the reply form provided. As a member, you agree to purchase at least 3 books within the next 2 years and may resign at any time thereafter.

BONUS BOOKS: Starting immediately you will be eligible for our *Bonus Book Plan* with savings of up to 80% off publishers' prices.

IRONCLAD NO-RISK GUARANTEE: If not satisfied with your books, return them within 10 days without obligation!

EXCEPTIONAL QUALITY: All books are quality publishers' editions especially selected by our Editorial Board. (Publishers' Prices Shown) BYP289

All books are hardcover unless numbers are followed by a "P" for paperback.
©1989 Computer Professionals' Book Society, Blue Ridge Summit, PA 17294-0870

Circle 62 on Reader Service Card

BYTE's Subscriber Benefits Program

Your BYTE subscription brings you a complete menu of the latest in microcomputer technology every 30 days. The kind of broad-based objective coverage you read in every issue. In addition, your subscription carries a wealth of other benefits. Check the check list:

BONUSES

- ✓ **Annual Separate Issues:** In addition to BYTE's 12 monthly issues, subscribers also receive our annual IBM PC issue free of charge, as well as special bound-in All-Macintosh Supplements.
- ✓ **BYTE Deck:** Subscribers receive five BYTE postcard deck mailings each year—a direct response system for you to obtain information on advertised products through return mail.
- ✓ **Reader Service:** For information on products advertised in BYTE, circle the numbers on the Reader Service card enclosed in each issue that correspond to the numbers for the advertisers you select. Drop the post-paid card in the mail and we'll get your inquiries to the advertisers.
- ✓ **TIPS:** BYTE's Telephone Inquiry System is available to subscribers who need *fast response* from advertisers. After obtaining your Subscriber I.D. Card, dial TIPS and enter your inquiries. You'll save as much as ten days over the response to Reader Service cards.
- ✓ **Free Programs Via BYTENet:** You get access to the BYTENet Bulletin Board Service, which allows you to download, via



modem, valuable program listings. There is no connect charge for this service.

- ✓ **Subscription Service:** If you have a problem with, or a question about your subscription, you may call our service department toll-free at 800-423-8272 (in New Jersey call 800-367-0218) during regular business hours (Eastern Time). You can also use Subscription Service to obtain back issues. Should you care to correspond, use the following address: P.O. Box 6821, Piscataway, N.J. 08855.
- ✓ **Editorial Indices:** Available through our customer service department P.O. Box 328, Hancock, New Hampshire 03449.

PAID SERVICES

- ✓ **BIX:** BYTE's Information Exchange puts you on-line 24 hours a day with your peers via computer conferencing and electronic mail. All you need to

sign up is a microcomputer, a modem, and telecomm software. For further information and cost, call 1-800-227-BYTE.

- ✓ **Program Listings:** Listings of programs that accompany BYTE articles are now available on BIX, on disks or in quarterly printed supplements (see reply cards in this issue for cost information), or call 1-800-258-5485.
- ✓ **Microform:** BYTE is available in microform from University Microfilm International in the U.S. and Europe. See Contents page for cost information.

DISCOUNTS

- ✓ One-year subscription at \$29.95
- ✓ Two-year subscription at \$54.95
- ✓ Three-year subscription at \$74.95
- ✓ One-year group subscription for ten or more at \$23.95 each. (Call or write for details.)

TOLL-FREE NUMBERS FOR YOUR CONVENIENCE:

Subscriptions & Back Issues:

1-800-423-8272
(in N.J., 1-800-367-0218)

BIX: 1-800-227-BYTE

Program Listings Orders:

1-800-258-5485

BYTE



TURBO PASCAL WINDOWING SYSTEM

TWindows lets you add windows to your application programs

Charles J. Butler

The user interface of an application can determine its success or failure. Windowing is the single most common user-interface tool and is especially important on personal computers, where users are often not computer experts.

Windows are used for data-entry screens, user prompts, status bars, light-bar menus, context-sensitive help screens—an endless list. Nearly every program I've written for the PC in the last few years has used a window in one form or another. Although I used windows in many applications, I found myself reinventing the tools each time. So I finally designed a windowing system that I could use in all my Turbo Pascal programs.

A window is an area on the screen, usually rectangular, that acts independently of the rest of the screen. There are two major differences between a window and a box drawn on the screen. First, when you open a window, all output to that window appears within the window's borders. If a line is too long to fit in the window, it either wraps to the next line or is clipped at the window's edge. If too many lines are displayed, the text in the window scrolls up to make room. Second, when you close a window, its borders and contents disappear from the screen, the text that was there before you opened the window reappears, the cursor

returns to its previous position, and the active text attribute is reinstated. In short, when you close a window, everything returns to the way it was before you opened it.

The TWindows system provides for nearly every function that you're likely to need from a windowing system. You can have up to 256 windows defined at one time, and you can select any open window for output. Each window can be opened, closed, and moved about on the screen. Each window can have an optional border composed of any combination of characters in the IBM character set, as well

as a header and footer that are either left justified, right justified, or centered in the border. Also, you have the option of saving the underlying screen and hiding the window for later recall.

Building an Abstract Data Type

I designed the TWindows windowing system to act as an *abstract data type*, which is a method of isolating data structures from *all the parts* of an application except the routines that are supposed to access them. That is, only the procedures and functions that act on the data structures—and not the structures themselves—are visible to the application. This information hiding reduces the conflict between the application and the windowing system, prevents direct access to the data

continued



structures, and allows you to change the implementation without changing the application program's source code.

In designing an abstract data type, you first decide which procedures and functions logically have access to the data structures. Furthermore, you should do this without regard to the final programming language. In the case of a Window data type, you need to be able to open and close each window individually and to select an open window for output. You may also need to hide, move, and resize windows.

The key to implementing an abstract data type is information hiding. The language must be able to limit the scope of some identifiers to a subset of an application's routines. These identifiers must be local in the sense that only some routines can see them, yet global in the sense that they retain their values be-

tween procedure and function invocations. Finally, you should use the language so that the collection of data structures and access routines forming the abstract type compile separately. This allows the window routines to remain independent of the applications that use it.

The *unit* construct in Turbo Pascal allows you to create abstract types by providing a mechanism for information hiding. The unit is composed of three distinct sections: the interface section, the implementation section, and the initialization section.

The interface section defines the elements that are visible to applications using the unit. These elements should include only the high-level access routines and constants that are needed to use the unit.

The implementation section of the unit contains the details of the data structures and access routines that make up the abstract type. Any constants, types, variables, procedures, and functions not directly needed by the user of the unit should be declared in this section. The bodies of the procedures and functions declared in the interface section are in the implementation section.

The initialization section ensures that the data structures are properly initialized before being used. This section executes before the main body of an application begins execution.

Defining the Data Structures

Since you can select any displayed window for output without first closing the current window, you'll need fast random access to each window so you can switch output to any one of multiple, tiled windows without closing each one in turn. This suggests the structure of an array of windows, but a window's definition and screen buffer requirements are too large to pre-allocate for all 256 windows. After all, many application programs will use only a few windows. A good compromise for both access speed and memory efficiency is a set of pointers to windows. Since each pointer takes 4 bytes of memory, the window system overhead is a fixed 1K byte (256 windows times 4 bytes per window).

As shown in figure 1, each window's array element points to a window definition record (WDR), which is dynamically allocated on the heap. The WDR for a window stores all the information necessary to display that window on the screen. This includes the window's coordinates, the characters that will make up the window's frame, header and footer titles, the text attributes for all the window's elements, and the cursor position and text attribute in effect when the window was last active.

The WDR also contains a pointer to another block of memory on the heap. This block of memory contains a copy of the data hidden under the window. This data is saved when you open a window and restored when you close it. You will want to save the underlying information when you use temporary pop-up windows, so you can restore the screen to its former state when you close the window. However, in many cases, such as with adjacent tiled windows that cover only the DOS screen, you may wish to avoid using the extra memory required for storing the underlying screen. The definition of the window determines whether or not to save the underlying screen.

The declarations necessary to implement the array of WDR pointers, *WinArray* and the WDR declaration itself, appear only in the implementation section of the unit so that they are invisible to the application program using the unit. Also, several declarations that allow other procedures and functions of the unit to address the screen directly appear in the implementation section. *ScreenArray* is an array of *ScreenLine* ele-

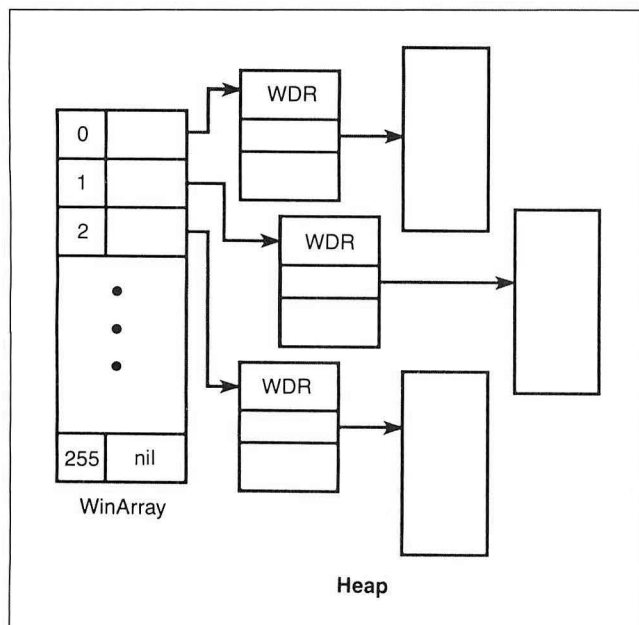

Figure 1: The structure of the window information consists of a 256-element array of pointers. When a window is defined, the array element points to the window structure, which in turn includes a pointer to a block of memory (heap) that holds either the screen data that is obscured by the window or the screen of a hidden window.

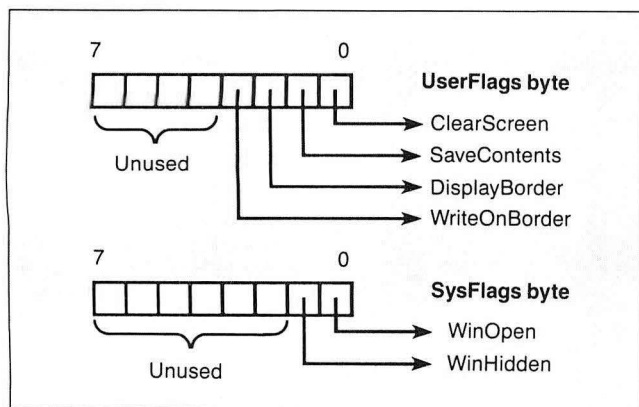

Figure 2: The structure of a defined window includes 2 bytes used for flags: *UserFlags* and *SysFlags*. Each significant bit in the bytes acts as a dual-state signal.

ments. ScreenLine is itself an array, each element of which represents one character on the screen. Each character in video memory is stored as 2 bytes (a word). The first, or lowest, byte is the ASCII code for the character, and the second is the attribute byte. The variable Screen, of type ScreenArrayPtr, points to video memory, allowing you to access it by assigning values directly to Screen (actually, the system will not assign values directly to Screen, as this would cause snow on many CGA monitors—see the section “Opening, Closing, and Selecting Windows” for an explanation).

Defining and Deleting Windows

Creating and using a window with this system is a two-step process (see listing 1). First, you define the window and open it. When you’ve finished using the window, close it or delete it. Closing a window will remove it from the screen and restore the underlying screen (if it was saved). The window can then be opened again at a later time. Deleting a window, however, will completely remove its definition from the system. It must then be redefined if you need it again.

Before you can open a window, you must define it with the procedure DefineWindow. DefineWindow takes as arguments a Window Identifier (WID), the *x*- and *y*-coordinates of the top-left and bottom-right corners of the window, the default attributes for the displayed text, frame-definition information, and a set of flags.

The frame-definition information includes the string of eight characters that make up the window’s border, starting from the top-left corner and proceeding clockwise around the frame, ending with the left-side character. If the string is less than eight characters long, the last specified character will repeat in all the remaining positions. Several common border strings are included as constants in the unit. Also included in the border definition are the header and footer titles and the attributes for the frame and titles. Each of the title strings can be left or right justified or centered on the top and bottom borders.

The UserFlags byte specifies four characteristics that a window can exhibit when opened. As shown in figure 2, each characteristic is represented by one bit in the UserFlags byte. The ClearScreen flag determines whether or not the window will be cleared after it is displayed on the screen. By not setting the ClearScreen flag, you can create an interesting see-through effect. The SaveContents flag determines whether or not the screen data under the window will be saved on the heap. If SaveContents is set, the underlying screen will reappear when you close the window.

Setting the DisplayBorder flag produces a frame around the window. The frame actually sits on top of the coordinates for the window, effectively reducing the window’s usable space by two rows and two columns. If DisplayBorder is not set, the entire space defined by the coordinates will be available for writing. Finally, the WriteOnBorder flag determines exactly where the Turbo Pascal Window coordinates will be set. If WriteOnBorder is set, the viewport will reside right on top of the border, allowing the Write and WriteLn procedures to place characters *on* the border. This is handy for drawing lines from border to border or for displaying special characters, such as arrowheads, to indicate that information has scrolled out of the window. If WriteOnBorder is not set, the viewport will be set just inside the border.

I’ve defined several constants in the interface section of the unit to assist you in building the UserFlags byte. Simply add these together to specify any combination of characteristics. The DefaultFlag constant represents the most commonly used

continued

Listing 1: *A short Turbo Pascal program that uses the functions and procedures of TWindows. Once a window has been defined, it can be opened, selected, moved, hidden, or deleted.*

```

program WinDemo2;

uses
  Crt, Dos, Wind20;

const
  Sample = 1;
var
  i,j: word;
  Ch: char;
  Col,Row,ColDel,RowDel,Color: byte;

begin
  Randomize;
  SetCursor(Off);

  { Define a small window in the upper left corner }
  DefineWindow(Sample,
    1,1,20,11,   Attr(Cyan,Black),
    DoubleUpBorder, Attr(LightCyan,Black),
    'Sample Header',Attr(Yellow,Black), Left,
    'Sample Footer',Attr(Green,Black), Center,
    DefaultFlag);

  { Open the window to display }
  OpenWindow(Sample);
  Delay(500);

  { Display random characters in the window }
  for i:= 1 to 5000 do
    begin
      Ch:= Char(Random(256));
      if (Ch<>#7) and (Ch<>#8) then
        Write(Ch)
      end;
      Delay(500);

  { Move the window around the screen at increasing
  speed }
  for i:= 1 to 200 do
    begin
      RelocateWindow(Sample,Random(59)+1,
        Random(13)+1);
      Delay(200-i)
    end;
  for i:= 1 to 200 do
    RelocateWindow(Sample,Random(59)+1,
      Random(13)+1);
  RelocateWindow(Sample,1,1);  { Back home }
  Delay(500);

  { Now show "smooth" window movement }
  for j:= 1 to 5 do
    begin
      for i:= 1 to 60 do
        MoveWindow(Sample,RightDir);
      for i:= 1 to 14 do
        MoveWindow(Sample,DownDir);
      for i:= 1 to 60 do
        MoveWindow(Sample,LeftDir);
      for i:= 1 to 14 do
        MoveWindow(Sample,UpDir)
    end;
  end;

```

continued

```

end;
Delay(500);

{ Show random overlapping windows }
for i:= 2 to 255 do
begin
  Col:= Random(78)+1; ColDel:= Random(78-Col)+2;
  Row:= Random(23)+1; RowDel:= Random(23-Row)+2;
  Color:= Random(16)+1;
  DefineWindow(i,
  Col,Row,Col+ColDel,Row+RowDel,Attr(Black,Color),
  SingleBorder,                Attr(Color,Black),
  '',0,Left,
  '',0,Left,
  DefaultFlag);
  OpenWindow(i);
end;
Delay(500);

{ Close and delete all the windows }
for i:= 255 downto 1 do
begin
  CloseWindow(i);
  DeleteWindow(i);
  Delay(20);
end;
Delay(500);

SetCursor(On);
SelectWindow(0);
end.

```

type of window. A default window will save the underlying screen, display a frame around the window, and clear the window after it is displayed.

There is also a SysFlags byte in the WDR. This byte is not directly accessible by the application, but the window system uses it to keep track of whether the window is open or hidden. Figure 2 shows SysFlag's format as well.

You should note that DefineWindow only builds a WDR for the window and does not actually cause the window to be displayed. This allows you to define all the windows that you will use in an application at the beginning of the program where they will be easy to find and maintain. In this way, you can change the characteristics of a window without hunting down the section of code that opens it. I usually designate ranges of the 256 possible WIDs for different purposes, such as help screens, data-entry screens, menus, status bars, and so on.

If you wish to reuse a WID or reclaim the heap space used for a window definition, you must use the DeleteWindow procedure. DeleteWindow takes a WID as a parameter. It will free the memory used to hold the WDR and reset the associated WinArray pointer to NIL, effectively undefining the window. The window must already be closed before you can delete it. The headings for DefineWindow and DeleteWindow appear in the interface section of the unit because they must be available to your application.

Opening, Closing, and Selecting Windows

At some point in the application, after you have defined a window, you will want to display it on the screen. You use the OpenWindow procedure for this purpose. OpenWindow takes a single parameter, the WID of the window to be opened. The information stored in the window's WDR determines the exact actions taken to display the window.

Before getting into the details of the OpenWindow algorithm,

it is helpful to understand the routines used to save an area of the screen to the heap and then to restore it back to the screen. I mentioned earlier that writing directly to video memory causes snow on some CGA monitors. For this reason, Turbo Pascal supplies the CheckSnow variable in the CRT unit. When set to TRUE, CheckSnow causes the Turbo output routines to wait for a horizontal retrace before writing directly to video memory. The MicroCalc program that Borland supplies with Turbo Pascal contains the same function in the procedures MoveToScreen and MoveFromScreen. These highly optimized assembly language routines move blocks of memory to and from video memory, while waiting for horizontal retrace if CheckSnow is set to TRUE, thereby avoiding snow on CGA monitors. The initialization section of the unit determines what display adapter you are using and sets CheckSnow accordingly.

The procedure SaveArea takes as parameters the coordinates of the top-left and bottom-right corners of the rectangle to be saved, as well as a pointer variable of type ScreenBlockPtr. Although the type ScreenBlockPtr is declared as a pointer to a 3440-word array (43 lines by 80 columns), SaveArea uses only enough memory to save the area under the window. Since the ScreenBlockPtr type allows you to address a block up to a full screen, you must avoid addressing past the actual amount of memory allocated on the heap. The memory required to save an area of the screen is the area's height times its width times 2 (the size of a word). In terms of the coordinates, this is

$$\begin{aligned}
 &(\text{RightCol} - \text{LeftCol} + 1) \times (\text{BottomRow} - \text{TopRow} + 1) \\
 &\quad \times 2 \text{ bytes}
 \end{aligned}$$

After a block of memory is allocated, MoveFromScreen copies the area of video memory out to the heap, a row at a time. The data must be copied row by row because MoveFromScreen (and MoveToScreen) expects to move contiguous blocks of memory, and only the data within a screen row is stored contiguously. The passed pointer variable is set to point to the heap block (or to NIL if there is a memory-allocation error).

The RestoreArea procedure is similar to SaveArea except that data is copied from the heap block back into video memory using the MoveToScreen routine. After the copy operation is complete, the block of heap memory is freed, and the passed pointer is set to NIL. Note here that the coordinates passed to SaveArea and RestoreArea do not have to be identical, but they must define the same length and width. Otherwise, the data will not be restored to the correct rows.

Before returning to the OpenWindow algorithm, you need one last procedure, DrawBorder, which simply draws a rectangular frame around the window area. But the justification and attribute options available for headers and footers complicate this otherwise simple procedure. DrawBorder takes as parameters the coordinates of the upper-left and lower-right corners of the window, as well as a record of type BorderDefType. This is the same record type used to store the border definition in the WDR. It holds the border-definition string, the header and footer text, justification specifications, and the attributes for displaying the border and title strings. First, DrawBorder builds the top and bottom borders in memory, complete with centered or justified titles, and then uses MoveToScreen to display them on the screen. It then displays the left and right borders, one row at a time.

The SaveArea, RestoreArea, and DrawBorder procedures are internal to the unit, since their headers do not appear in the interface section. The window system uses these procedures for

continued

Our MAJOR ADVANTAGE - Supplying you with the Broadest Range of Software Ammunition.



ADVANTAGE SOFTWARE

CAD	
AutoCAD	2895 CALL
Design CAD	299 165
Draftix 3D Modeler	295 199
Generic CADD	100 79
Generic CADD Level 3 Schema II	200 149
	495 439

COMMUNICATIONS	
Carbon Copy +	195 120
Close Up - Customer	195 171
Close Up - Support	245 245
Crosstalk MK IV	245 159
Crosstalk XVI	195 99
Relay Gold	250 164
Smartcom III	249 162

DATABASE	
Clipper	695 439
dBASE III +	695 385
dBASE IV	795 485
dBASE IV Dev. Edition	1295 899
FoxBASE +	395 335
Genifer	395 259
R & R	149 119
Tom Reffig's Library	80 75

DESKTOP PUBLISHING	
ByLine	295 185
GEM/3 Desktop Publisher	299 189
Pagemaker	595 429
PFS: First Publisher	129 79
Ventura Desktop Publisher	899 590

GRAPHICS	
AutoSketch	100 85
Chart Master	375 205
Chart Master Premium Pack	395 225
Chart	395 272
Draftix 1 Plus	295 265
Freelance Plus	495 322
Graph-In-the-Box	140 109
Harvard Graphics	495 343
In a Vision	495 290
Sign Master	245 140
Time Line Graphics	195 119

LANGUAGES	
APL*PLUS	695 476
Lattice C	450 279
Lahey FORTRAN F77L	477 453
Microsoft C	450 299
NDP Fortran or C-386	595 529
Turbo C	150 105
Turbo C Professional	250 175
Turbo Pascal	150 105
Turbo Pascal Professional	250 175
Zortech C++	100 90

PROGRAMMING UTILITIES	
Flowcharting II Plus	229 207
Interactive Easyflow	150 135
OPT-TECH SORT/MERGE	149 99
PolyAWK	99 90
Pro-C	495 459
Windows for Data	295 259

LOTUS ADD-ONS	
4Views	150 119
4Word	100 79
@bASE	195 121
Allways	150 117
Al Liberty	295 199
Graph-In-the-Box	140 109
Inword	100 80
Look & Link	100 64
Note-It Plus	80 68
Noteworthy	80 59
R & R (Lotus Version)	149 119
See More	80 65
Sideways	70 45
Smartnotes	80 69
SpellIt	80 65
SqzIt Plus	100 CALL

PLANNING	
Harvard Total Project II	595 545
Project 4.0	495 340
Super Project Expert	695 545
Time Line 3.0	595 345
Time Line 2.0	495 306

SCIENCE AND ENGINEERING	
Asystant Plus	895 849
DADISP	795 719
Eureka: The Solver	167 119
Gauss Math + Stat Package	395 359
HiWIRE-Plus	895 805
Labtech Notebook	995 799
MathCAD	349 279

LIST OURS	
Micro-Cap III	1495 1269
T3 Scientific Word Processor	595 499
Target PCB	495 469
TK Solver Plus	395 349

SPREADSHEET	
LOTUS 1-2-3	495 289
Multiplan	195 129
PC-Excel	495 299
Supercalc IV	495 349

STATISTICS	
CSS	495 459
Microstat II	395 349
NWA Statpak	399 359
SPSS/PC	795 749
Systat	595 549
Systat/Sygraph	795 709

WINDOWS	
Actor	495 429
DesqVIEW	130 89
VM/386	245 169
Windows/286	99 69
Windows/386	195 130
Windows Devel. Toolkit	500 319

WORD PROCESSING	
Displaywrite IV	495 425
Manuscript	495 322
Multimate Adv. II	565 271
Q & A Write	349 207
Samna Word IV	595 343
Volkswriter V3	295 170
Word Perfect v. 5.0	495 228
Word	450 199
Wordstar Pro v. 5.0	495 290

UTILITIES	
4DIR +	95 59
Copy II PC	40 35
Copy II PC Option Board	159 139
Disk Optimizer	70 63
Disk Technician	100 89
Disk Technician Plus	190 175
Fastback Plus	189 109
HTEST	90 79
Make Utilities	99 85
Norton Commander	75 45
Org Plus	80 59
PC Tools Deluxe	79 69
Prokey	130 81
Sidekick	85 59
Software Carousel	80 60
V Cache	60 55
V Feature Deluxe	120 111
Vopt	60 55
Xtree	70 60
Xtree NET	295 249
XtreePro	129 111

ASHTON TATE	
ByLine	295 185
Chart Master	375 205

LIST OURS	
Chart Master Premium Pack	395 225
C Tools Graphics Library	90 69
C Tools Programmer's Library	90 69
dbASE III +	695 385
dbASE IV	795 485
dbASE IV Developer's Edition	1295 899
dbASE Mac	495 325
dbASE Programmer's Utility	90 69
Diagram Master	345 190
Diagram Master Prem. Pack	365 206
Draw Applause	495 309
Framework III	695 405
Front Runner	195 121
Full Paint	100 65
Full Write Professional	395 236
Map Master v. 6.01	395 240

LIST OURS	
MS BASIC/6.0	295 199
MS C	450 299
MS COBOL	900 599
MS Excel	495 299
MS FORTRAN	450 299
MS Learning DOS	50 40
MS Mach 20	495 329
MS Macro Assembler	150 99
MS Mouse Bus or Serial w/ Paintbrush & Mouse	
Menus	150 99
w/ EasyCAD	175 119
w/ Paintbrush & Windows	200 139
MS Multiplan	195 129
MS OS/2 Prag. Toolkit	350 229
MS Pascal	300 199
MS Project 4.0	495 340
MS QuickBASIC	99 69
MS QuickC	99 69
MS Sort	195 130
MS Windows	99 69
MS Windows/386	195 130
MS Windows Dev. Kit	500 319
MS Word	450 199
MS Works	149 99

LIST OURS	
Turbo Assembler/Debugger	150 105
Turbo C 2.0	150 105
Turbo C 2.0 Professional	250 175
Turbo Lightning	100 69
Lightning Word Wizard	70 49
Turbo Lightning and Lightning Word Wizard	150 109
Turbo Pascal 5.0	150 105
Turbo Pascal 5.0 Professional	250 175
Tutor	70 45
Turbo Prolog	150 105

LOTUS DEVELOPMENT	
Agenda	395 299
Freelance +	495 322
Graphwriter II	495 337
Hal	150 89
Lotus 1-2-3	495 289
Lotus Metro	85 59
1-2-3 Report Writer	95 69
Manuscript	495 325
Signal	595 553
Symphony	695 422

MICROSOFT	
MS BASIC/6.0	295 199
MS C	450 299
MS COBOL	900 599
MS Excel	495 299
MS FORTRAN	450 299
MS Learning DOS	50 40
MS Mach 20	495 329
MS Macro Assembler	150 99
MS Mouse Bus or Serial w/ Paintbrush & Mouse	
Menus	150 99
w/ EasyCAD	175 119
w/ Paintbrush & Windows	200 139
MS Multiplan	195 129
MS OS/2 Prag. Toolkit	350 229
MS Pascal	300 199
MS Project 4.0	495 340
MS QuickBASIC	99 69
MS QuickC	99 69
MS Sort	195 130
MS Windows	99 69
MS Windows/386	195 130
MS Windows Dev. Kit	500 319
MS Word	450 199
MS Works	149 99

PRIMARY TARGET

MICROSOFT EXCEL.

The soul of the new machines. Microsoft Excel takes full advantage of the power of 286- and 386-based computers.

It lets you work faster and consolidate data more easily. It lets you create annual-report-quality output and produce presentation graphics. And it lets you create macros easily and build custom programs.

Since Microsoft Excel is compatible with Lotus 1-2-3, it's easy to integrate into your office.

Find out why we call it the most powerful spreadsheet for powerful personal computers. List: \$495 Ours: \$299



Microsoft®

LIST OURS	
Multimate Adv. II	565 271
Pascal Tools Prog. Lib.	90 72
Programmer's Utility II	90 69
Rapid File	295 195
Sign Master	245 139

BORLAND	
Eureka: The Solver	167 119
Paradox 2.0	725 529
Paradox Network Pack	995 729
Paradox 386	895 625
Quattro	247 169
Reflex & Reflex Workshop	200 139
Reflex Data Base Systems	150 109
Reflex Workshop	70 49
Sidekick	85 59
Sidekick Plus	200 139
Sprint	199 139
Superkey	100 69
Turbo Basic	100 69

LIST OURS	
PETER NORTON PUBLISHING	
Norton Commander	89 55
Norton Editor	75 50
Norton Guides:OS/2	150 109
Norton Guides:Speciy Lang.	100 75
Norton Utilities	100 59
Advanced Version	150 99

SOFTWARE PUBLISHING	
Harvard Graphics v. 2.1	495 313
Harvard Total Project Mgr.	595 515
PFS: Access	140 91
PFS: First Choice v. 2.0	159 104
PFS: First Publisher v. 2.0	129 75
PFS: Graph	140 91
PFS: Professional File	249 155
PFS: Professional Plan	249 161
Professional Write v. 2.0	199 125
US Mapmaker	149 89

Terms & Policies

All prices subject to change without notice. We accept Visa, MC, AMEX (2% surcharge on AMEX). Shipping \$4 per item sent UPS Ground. Allow 14 days for personal/company check clearance. Returns subject to 15% restocking fee. RA # required. PO's welcome from Fortune 1000 and other qualified organizations.



ADVANTAGE SOFTWARE

In the U.S. call:

1-800-333-3141

N.Y./International: **914-332-0756**

Fax: **914-332-4021**

55 South Broadway, Suite B, Tarrytown, NY 10591

its own purposes; they are not intended for the application's use. This kind of procedure hiding prevents inappropriate use of these support routines. Since the `SaveArea`, `RestoreArea`, and `DrawBorder` procedures are called exclusively from internal routines, they expect to be passed valid coordinates and do not recheck them. Should the application call these routines without providing proper error checking, some unpredictable results might occur.

`OpenWindow` looks at the `UserFlags` byte in the `WDR` to determine how the window should be displayed. If the `SaveContents` bit of `UserFlags` is set, `OpenWindow` calls `SaveArea` to save the underlying screen contents. `OpenWindow` passes the coordinates from the `WDR`, as well as the `SaveScreen` pointer, as parameters to `SaveArea`. `SaveArea` then saves the screen area under the window and gives `SaveScreen` a pointer to this area.

Next, the current window's cursor position and active text attribute are recorded in its `WDR`. When you select the current window with `SelectWindow` (described later), this information is used to restore the window to its former state. Then, if the `DisplayBorder` flag is set, `DrawBorder` displays the new window's frame. The parameters are the `WDR`'s coordinates and the `BorderDef` record.

Now, if the `ClearScreen` `UserFlags` bit is set, `OpenWindow` calls the Turbo Pascal `Window` procedure to define a temporary viewport for a subsequent call to `ClrScr`. If the frame is displayed, then the viewport is set just inside the frame; otherwise, it is set right on the window's coordinates.

Finally, `OpenWindow` defines the window's permanent viewport by using the settings of the `DisplayBorder` and `WriteOn-`

`Border` flags. If there are no borders, or if the `WriteOnBorder` `UserFlags` bit is set, the window's coordinates define the viewport. Otherwise, the viewport is set just inside the window's coordinates. After completely displaying the window, `OpenWindow` updates several housekeeping variables—it sets the `ActiveWin` variable to the new `WID`, it marks the window as open in its own `WDR` (using the `SysFlags` byte), and it increments the total number of open windows.

You use the `CloseWindow` procedure to remove a window from the screen. `CloseWindow` takes a single parameter, the `WID` of the window you want to close. `CloseWindow` is similar to `OpenWindow`, except that it uses `RestoreArea` to copy the underlying screen area back to video memory from the heap. Of course, it does this only if `OpenWindow` saved the screen. Most other actions are the reverse of those taken by `OpenWindow`.

If the currently active window is the one that you are closing, `CloseWindow` selects `Window 0`, the full screen, as the active window. You may wonder why it doesn't restore the previously active window. Without having a complete history of the open and close sequence, it is impossible for the window system to determine which window to make active. For example, if you open windows A, B, and C and then close B, you cannot reselect B when you close C. There are similar problems with hidden windows (described later). For these reasons, after closing an active window, you must explicitly select the next active window with the `SelectWindow` procedure.

Most applications that use windows have more than one open at a time. `OpenWindow` automatically selects the new window as the active window. This means that all screen output statements

Every copier company talks We're doing something about

Choosing a new copier isn't easy. You look at copiers, you listen to promises. It all gets very confusing.

Now, you don't have to listen to a lot of talk about promises. You can read ours. Because we put it in writing. If you try to compare it to other copier guarantees, you'll find there's no comparison. Suddenly, a difficult decision becomes a very easy choice to make.

Look at the certificate above. Nobody offers you as good a copier guarantee as Harris/3M. So, while

copier salespeople are all giving you a lot of talk, ours will give you something great to read.

Send in the coupon. Or give us a call at 1-800-TLC-COPY. (In Canada, 1-519-668-2230.) We'll send you our 8-page *Consumer Guide to Copiers*. Then, we can talk about it.



Harris/3M copiers have features for all sizes of offices. That includes the 6070. Seventy copies a minute, guaranteed.

affect that window. When it becomes necessary to update another open window without closing the first, you must explicitly select the other window with `SelectWindow`.

`SelectWindow` takes a `WID` as a parameter. The window must already be defined, opened, and not hidden. All subsequent screen output statements affect the newly selected window. Whenever you select a new window, the previously active window's `WDR` holds its cursor position and text attribute so it can be restored when the window becomes active again. `SelectWindow`'s primary task is to reset the Window viewport by using the same algorithm as `OpenWindow` with the `DisplayBorder` and `WriteOnBorder` flags. After setting the new viewport, `SelectWindow` restores the cursor position and text attribute that were in effect when the window was last active. Finally, the procedure updates the `ActiveWin` variable.

The `OpenWindow`, `CloseWindow`, and `SelectWindow` procedures are all available to the application, so their headers appear in the unit's interface section.

Hiding and Displaying Windows

An interesting feature of this system is that it allows you to hide windows. When you hide an open window using `HideWindow`, the procedure saves the contents of the current window on the heap. The underlying screen area is restored to the screen. The visual effect is the same as if the window were closed, except that the window and its contents are restorable.

`HideWindow` takes a `WID` as a parameter. It first copies the current contents of the window to a new screen block on the heap using the `SaveArea` procedure. It then restores the under-

lying screen area from the heap using the `RestoreArea` procedure. Finally, it points the window's `WDR SaveScreen` variable to the saved screen block.

When you hide a window, you cannot select it for output. Also, if the window you hide is the currently active window, then Window 0, the full screen, becomes the new active window. If this happens, you must explicitly select a new window with the `SelectWindow` procedure. `HideWindow` also does several housekeeping chores such as flagging the window as hidden and incrementing the count of hidden windows.

You use the `DisplayWindow` procedure to redisplay a hidden window. `DisplayWindow` takes a `WID` as a parameter. It is the reverse of `HideWindow`; that is, it saves the underlying screen area to the heap and restores the previous contents of the window from the heap to the screen. Once a window is restored, you can select it for output.

An interesting aspect of hiding and restoring windows is that you can change the coordinates of a hidden window, and when you reselect it, it will appear in the new position on the screen with its previous contents. Although an application program cannot directly change the coordinates in a `WDR`, the `RelocateWindow` procedure performs this action automatically.

Relocating and Moving Windows

The most common reason for providing ways to move windows is to let users position windows to their taste.

The window system supplies two procedures for moving windows about on the screen—`RelocateWindow` and `MoveWin-`

continued

about customer satisfaction.

it.



Yes, I'd like to know more about Harris/3M copiers and the Harris/3M Copier Promise.
Send to Harris/3M, P.O. Box 785, Dayton, OH 45401

NAME _____

COMPANY NAME _____

ADDRESS _____

CITY _____ STATE _____ ZIP _____

PHONE # () _____

_____ I'd also like information on your fax machines. MH289

HARRIS/3M

Offer is valid for a limited time and other restrictions and limitations apply; see your Harris/3M sales representative for details. ©1988 Harris/3M Document Products, Inc. Harris is a trademark of the Harris Corporation. 3M is a trademark of the 3M Company.

Table 1: *The TWindows functions and procedures in this table are all that an application program can see of the unit. Although there are other internal functions, procedures, and variables in the window unit, they are invisible to the application program.*

procedure DefineWindow (WindowID : byte; LeftCol : byte; TopRow : byte; RightCol : byte; BottomRow : byte; WindowAttr : byte; BorderStr : BorderStrType; BorderAttr : byte; HeaderStr : TitleStrType; HeaderAttr : byte; HeaderJust : JustifyType; FooterStr : TitleStrType; FooterAttr : byte; FooterJust : JustifyType; UserFlags : byte);	Creates a new window definition Window ID number (WID) Left-column coordinate Top-row coordinate Right-column coordinate Bottom-row coordinate Attribute for window writes String to use for border characters Attribute for border characters String for header text Attribute for header text Justification for header string String for footer text Attribute for footer text Justification for footer string User flags
procedure DeleteWindow (WindowID : byte);	Deletes a window from the system, freeing the heap space used. Window ID number
procedure OpenWindow (WindowID : byte);	Displays a window on the screen. The window must already be defined and not already open. Window ID number
procedure CloseWindow (WindowID : byte);	Removes a window from the screen and redisplay the underlying contents, if it was saved by OpenWindow. Window ID number
procedure SelectWindow (WindowID : byte);	Selects a window for output. Window ID number
procedure HideWindow (WindowID : byte);	Differs from CloseWindow in that the contents of the window are saved and can be restored. Window ID number
procedure DisplayWindow (WindowID : byte);	Undoes the action of HideWindow. Window ID number
procedure RelocateWindow (WindowID : byte; NewLeftCol : byte; NewTopRow : byte);	Moves an open window to a new position on the screen. Window ID number New left column New top row
procedure MoveWindow (WindowID : byte; Direction : DirectionType);	Moves an open, displayed window by one row or column in a specified direction. Window ID number Direction to move WindowID
function WindowDefined (WindowID : byte) : boolean;	Returns a true if WindowID is defined. Window ID number
function WindowOpen (WindowID : byte) : boolean;	Returns a true if WindowID is currently open. Window ID number
function WindowHidden (WindowID : byte) : boolean;	Returns a true if WindowID is currently hidden. Window ID number
function ActiveWindow : byte;	Returns the WindowID of the currently active window.
function WinError : byte;	Returns the error status of the last window operation.
function Attr (Foreground : byte; Background : byte) : byte;	Returns the attribute byte necessary to display characters using foreground and background colors. Foreground color Background color
procedure SetCursor (OnOff : Switch);	Turns the cursor on or off based on Switch.
function Mono : boolean;	Tests for monochrome adapter.
function EGAInstalled : boolean;	Tests for the presence of an EGA.

dow. They differ in their use, their visual effects on the screen, and the complexity of their algorithms.

`RelocateWindow`, the simplest of the two, takes a `WID` and the new coordinates of the top-left corner of the window as parameters. The procedure moves a window by first hiding it, then recalculating the new coordinates of its bottom-right corner, and then redisplaying it at its new position. If the window is already hidden, only the coordinates are changed—the window is *not* redisplayed. Since the `HideWindow` procedure automatically restores the underlying screen area, `HideWindow` is useful for moving a window to a distant position in a quick jump.

The parameters of `MoveWindow`, on the other hand, are not new screen coordinates, but rather a direction to move. `MoveWindow` moves the window either a single row or column, depending on the direction parameter. The result is a smoother movement than with `RelocateWindow`.

To achieve this, the screen block used to store the underlying screen area is “spliced” with the newly covered row or column. Only the newly uncovered row or column is restored to the screen. The window’s information moves to its new position using the `MoveFromScreen` and `MoveToScreen` procedures.

Moving a window up and down is fairly straightforward. First, the row about to be covered over is saved to a temporary location on the heap. Second, the window is moved row by row in the direction specified by the direction parameter. Third, the row just vacated is restored from its position within the heap screen block back to video memory. Fourth, the heap block is shifted either up or down by the amount of memory necessary to store one row of data in order to make room for the newly covered row. Finally, the row temporarily saved in step one is moved into the heap block and its memory freed.

Moving a window left and right is complicated by the fact that the screen block data is laid out on the heap in a row-by-row fashion. In this case, it is a screen column that is saved, restored, and spliced into the screen block. This means that each row section of the block must be shifted up or down by 2 bytes (one word) to make room for a new screen character within each row. After the window is moved by one column on the screen, the saved column is spliced into the screen block one character at a time, at either the beginning or end of each row, depending on the direction of movement.

On my 8-MHZ AT clone (with an EGA card), the window movement is fast enough to simulate the real-time, smooth movement required for applications that allow the end user to move windows with the arrow keys.

Using the TWindows System

When an application using this windowing unit starts up, the initialization section is the first to execute. It begins by installing a new heap error function, `HeapFunc`, which causes memory-allocation errors to return `NIL` pointers. In this way, the application can recover should it run out of free heap space. If your application already performs this function, you can remove this code from the unit.

The initialization section goes on to set all elements of `WinArray` to `NIL`, and to allocate and initialize a `WDR` for `Window 0`. `Window 0` represents the full screen; you cannot redefine, open, close, hide, or move it. You can, however, select it. If you select `Window 0` at the end of your application, the cursor position and text attributes will return to the values in effect when you started up the application.

The start-up code then determines the video card installed and sets the variable `Screen` to point to the proper location for video memory. It also sets `CheckSnow` to `FALSE` if you are

using either a monochrome or an EGA adapter.

As mentioned earlier, you must define a window before you can use it. By defining all your windows at the beginning of your application’s code, you will find it easy to “tweak” window coordinates and attributes during development. To reduce the time it takes to enter a complete window definition, I have included some common border strings as constants in the interface section. You will find the `Attr` function useful. It takes two color parameters and returns an attribute byte. Here is a sample `DefineWindow` call:

```
MainMenu:=1;
DefineWindow
  (MainMenu,
   10,5,30,10,Attr(LightCyan,Black),
   DoubleBorder,Attr(LightCyan,Black),
   ' Main Menu ',Attr(Yellow,Black),Center,
   ' ',0,Left,
   DefaultFlag);
```

Notice that if you don’t need a footer in the bottom border, you can specify a null string as the footer text. The values of the footer attribute and justification specification are not used.

After you define the window, you can open it with a call to `OpenWindow`. Since `OpenWindow` automatically selects the window for output, a `SelectWindow` is not necessary. However, if you select a different window later, you can reinstate this window as the active window with

```
SelectWindow(MainMenu);
```

There are several inquiry functions you can use to probe the window environment without actually knowing anything about the internal representation of the data structures. The system has built-in error checking that will display an error message if an error occurs during one of the interface procedure calls. After you debug the application, you can disable the message printing, but the application can still check the error status after each call by using the `WinError` function. `WinError` returns the value of the `WError` variable and then resets it to 0. Table 1 lists all the available functions and procedures.

You may have noticed that this system conspicuously lacks a `ResizeWindow` procedure. To be quite honest, I haven’t yet needed to resize a window. Most windows contain forms that are preformatted for a certain area. An application that allows editing data in a window might well allow you to change the window’s size at run time (`SideKick` is a good example). A `ResizeWindow` procedure would resemble `MoveWindow`, in that the heap screen block would be spliced with new screen data as you resize the window. When the resizing operation is complete, a new heap block would be used for the new underlying screen area in order to keep the data contiguous in memory.

The complete source code of the window unit and a demonstration program, `Windemo`, is available in a variety of formats (see page 3 for details). The demonstration program runs through all the features available through this system. It is configured for a color, 25-row by 80-column display, but this is easily changed. The system supports all 80-column text modes available on the PC. The maximum values of the row and column coordinates are determined when you define the first window. `Window 0`, the full screen, will then be active. ■

Charles J. Butler is a systems engineer at the Federal Home Loan Mortgage Corp. offices in Reston, Virginia. He can be reached on BIX as “cjbutler.”

SAVE 15% ON MCGRAW-HILL COMPUTER BOOKS AND SOFTWARE

INTRODUCING PC-DOS AND MS-DOS

By T. Sheldon. 374 pp., illus., softbound Find out about the free advanced capabilities of DOS and how to use them. "Wonderfully enlightening. . . well-written. . . my pick for technical book of the year." — *Online Review* 056559-7.

Regular Price: \$24.95

Your Price: \$21.20.

EGA/VGA: A Programmer's Reference Guide

By B. Klieiwer. 269 pp., softbound The first to detail technical aspects of the new IBM Enhanced Graphics Adapter and Virtual Graphics Display—how to design programs for these leading graphics standards. 035089-2

Regular Price: \$24.95

Your Price: \$21.20.

HOW TO BE A SUCCESSFUL COMPUTER CONSULTANT

By A.R. Simon. 256 pp., illus., softbound Everything you have to know to set up and run your own computer consultant (or software development) business, full- or part-time. No business experience required! 057296-8.

Regular Price: \$19.95.

Your Price: \$16.95.

A COMPREHENSIVE GUIDE TO AI AND EXPERT SYSTEMS

By R.I. Levine, D.E. Drang, & B. Edelson. 256 pp., 99 illus., softbound All about artificial intelligence and how to utilize it on your personal computer. Gives you everything from basic concepts to sophisticated programming techniques. 037470-8.

Regular Price: \$22.95

Your Price: \$19.50

Also available in a TURBO PASCAL Edition! This new edition shows you how to apply AI programming techniques to create expert systems in TURBO PASCAL for your own use. 037476-8.

Regular Price: \$19.95

Your Price: \$16.95.

INTRODUCING UNIX™ SYSTEM V

By R. Morgan & H. McGilton. 480 pp., illus., softbound Guides you step by step through the facilities, commands, utilities, and applications of System V, AT&T's new version of the UNIX operating system. 043152-3.

Regular Price: \$24.95

Your Price: \$21.20

UNIX™ UTILITIES:

A Programmer's Guide

By R.S. Tare. 640 pp., illus., softbound Save time and effort with popular UNIX utilities! Helps you write efficient, bug-free programs and significantly reduce turnaround time. 062884-X

Regular Price \$24.95

Your Price: \$21.20

DATABASE EXPERT'S GUIDE TO DATA-BASE2

By B. Larson. 442 pp. The first to provide in-depth coverage and instruction in Database2 for programmers, database administrators and others with mainframe database experience. Make sure you're ready by IBM's conversion date of 1992!

Hardcover: 036488-5 Regular Price: \$39.95 **Your Price: \$33.95**

Softcover: 023267-9 Regular Price \$24.95 **Your Price: \$21.20.**

DATABASE EXPERT'S GUIDE TO SQL

By Frank Lusardi. 224 pp. This user-friendly guide provides programmers and managers with a thorough introduction to Structured Query Language (SQL) and relational database concepts. It describes the language's constructs and guides you through complex syntactical possibilities, while emphasizing SQL's practical use in designing and implementing databases.

Hardcover 039006-1 Regular Price: \$39.95 **Your Price: \$33.95.**

Softcover 039002-9 Regular Price: \$24.95 **Your Price: \$21.20.**

MICROEXPERT SOFTWARE

By B. Thompson & W. Thompson. Your own expert system! This affordable expert system shell allows you (beginner or programmer) to see how a system works as you build it yourself.

Software includes tutorial for design of knowledge base and creation of rules. Source code provided. "Highly recommended," *Online Today*.

IBM PC 852109-2 Regular Price: \$64.95 **Your Price: \$55.20.**

Apple II 852110-6 Regular Price: \$54.95 **Your Price: \$46.70.**

HARD DISK MANAGEMENT IN THE PC & MS DOS ENVIRONMENT

By Thomas Sheldon. 224 pp., illustrated. This guide for organizing and managing a hard disk system gives procedures needed to build a menu system and directory structure.

Softcover 056556-2 Regular Price: \$24.95 **Your Price: \$21.20.**

FOR FAST SERVICE CALL 1-800-2-MCGRAW OR MAIL THIS COUPON
Prices subject to change without notice.

McGraw-Hill Publishing Company
P.O. Box 400, Hightstown, NJ 08520

15-DAY FREE EXAMINATION

Please send me — at 15% off the regular price — the products whose code numbers (the number before the regular price in above advertisement) I have checked below. I understand I have 15 days for free examination before I send payment for those titles I want to keep (plus postage, handling, and local tax) and return any unwanted products postpaid.

- | | | |
|-------------------------------------------|-------------------------------------------|-------------------------------------------|
| <input type="checkbox"/> 056559-7 \$21.20 | <input type="checkbox"/> 043152-3 \$21.20 | <input type="checkbox"/> 039002-9 \$21.20 |
| <input type="checkbox"/> 035089-2 \$21.20 | <input type="checkbox"/> 062884-x \$21.20 | <input type="checkbox"/> 852109-2 \$55.20 |
| <input type="checkbox"/> 057296-8 \$16.95 | <input type="checkbox"/> 036488-5 \$33.95 | <input type="checkbox"/> 852110-6 \$46.70 |
| <input type="checkbox"/> 037470-8 \$19.50 | <input type="checkbox"/> 023267-9 \$21.20 | <input type="checkbox"/> 056556-2 \$21.20 |
| <input type="checkbox"/> 037476-8 \$16.95 | <input type="checkbox"/> 039006-1 \$33.95 | |

Name _____

Address _____

City _____ State _____ Zip _____



23-F229-5000-1

HARD DISK INTERFACES

The interface you pick can dramatically affect your system's performance

Nowadays, many microcomputer manufacturers' performance claims center around hard disk drive interfaces and the encoding schemes they use—usually described by acronyms like RLL (run length limited), ESDI (enhanced small device interface), and SCSI (small computer system interface). How do these interfaces work, and what effects do they really have on performance? In this installment of *Under the Hood*, I'll describe some of the most popular interfaces for microcomputer hard disk drives and explain what you can expect from each one.

The Big Picture

To get the right perspective on these interfaces, it's important to see how hard disk drives fit into the larger scheme of things. Figure 1 shows the full range of interfaces, from the low-end ST506 (used on the IBM PC XT and AT, among others) to the fast, powerful, and expensive IPI (intelligent peripheral interface) used on many mainframes.

As microcomputer users, we're most interested in those interfaces that are found in the low and middle ranges, including ST506/ST412, ESDI, and SCSI. SMD (storage module device) is a venerable mainframe interface seen infrequently on microcomputers but occasionally used to connect large disk drives to microcomputer file servers.

ST506: The First Standard

The use of hard disk drives on microcomputers is a relatively recent phenomenon. While they were available for many early

machines (S-100 systems and even the Apple II), the boom did not begin until 5¼-inch hard disk drives first appeared in the early 1980s. Shugart Technology (now Seagate Technology) pioneered the manufacture of these small-form-factor disk drives with the 5-megabyte ST506 hard disk drive.

The ST506 was derived from two other interfaces: the SA450 interface for 5¼-inch floppy disk drives and the SA1000 interface for 8-inch hard disk drives. Like the SA450, the ST506 used a 34-pin daisy-chain cable for control signals; like the SA1000, it used individual 20-pin "radial" cables to carry data between the controller and each disk drive (see table 1). It's no coincidence that this feature also allowed cables from existing disk drives to be used on newer ones.

The ST506 interface was designed to read and write data at a maximum rate of 5 megabits per second—not as fast as a disk drive using SMD (the mainframe standard of the day), but still faster than the microcomputers available at that time could accept.

A problem with the original ST506 interface was that, as with a floppy disk drive, the read/write head had to be stepped (moved across the disk) one track at a time by carefully timed pulses. Since these pulses actually caused the read/write head's stepper motor to advance a notch, they could not proceed faster than the disk drive could move the head.

The ST412 disk drive introduced an enhancement that eliminated this problem: the *buffered seek*. Instead of requiring the controller to slow the pulse rate to whatever the mechanism could handle, the ST412 simply counted the pulses as they came in. It then decided for itself how fast to step the head to move the required number of tracks.

Enter RLL Encoding

While the ST506 standard was sufficient for many applications, disk drives were

still expensive. Thus, manufacturers sought ways to pack more data onto a single ST506 disk. Many companies began to use a compression technique invented by IBM called RLL encoding, which squeezed 50 percent more space and speed out of an ST506 disk drive. To use RLL, you need a controller that's specially designed to use this encoding scheme (see the text box "RLL Encoding" on page 296).

At first, using RLL encoding on an ST506-type disk drive was a risky proposition. RLL requires higher precision in the recording circuitry, medium, and disk drive mechanism than the usual modified-frequency-modulation (MFM) encoding technique. Thus, for RLL, disk drive manufacturers had to add tests that certified correct operation. Today, however, virtually all manufacturers offer RLL-certified disk drives that meet the higher tolerances.

A typical ST506/RLL disk drive will provide a net data transfer rate of 7.5 megabits per second, and because it can fit more data on a track than a non-RLL disk drive, it will probably need to step the heads less often as well.

Advanced and Enhanced RLL

The initial RLL schemes had the advantage of expanding disk drive capacity while keeping the repetition rate—the maximum frequency of the pulses present on the data cable—at or below the rated 5 MHz. Some controller manufacturers, however, attempted to increase the repetition rate as well, to 6.7 MHz. These schemes—ARLL (advanced RLL) and ERLL (enhanced RLL)—resulted in a 100 percent increase in space and data transfer rates over the original ST506 designs.

ARLL and ERLL systems experience more problems than RLL systems, however, because they push the disk drives far beyond their original design limits. At these speeds, the disk drives became

continued

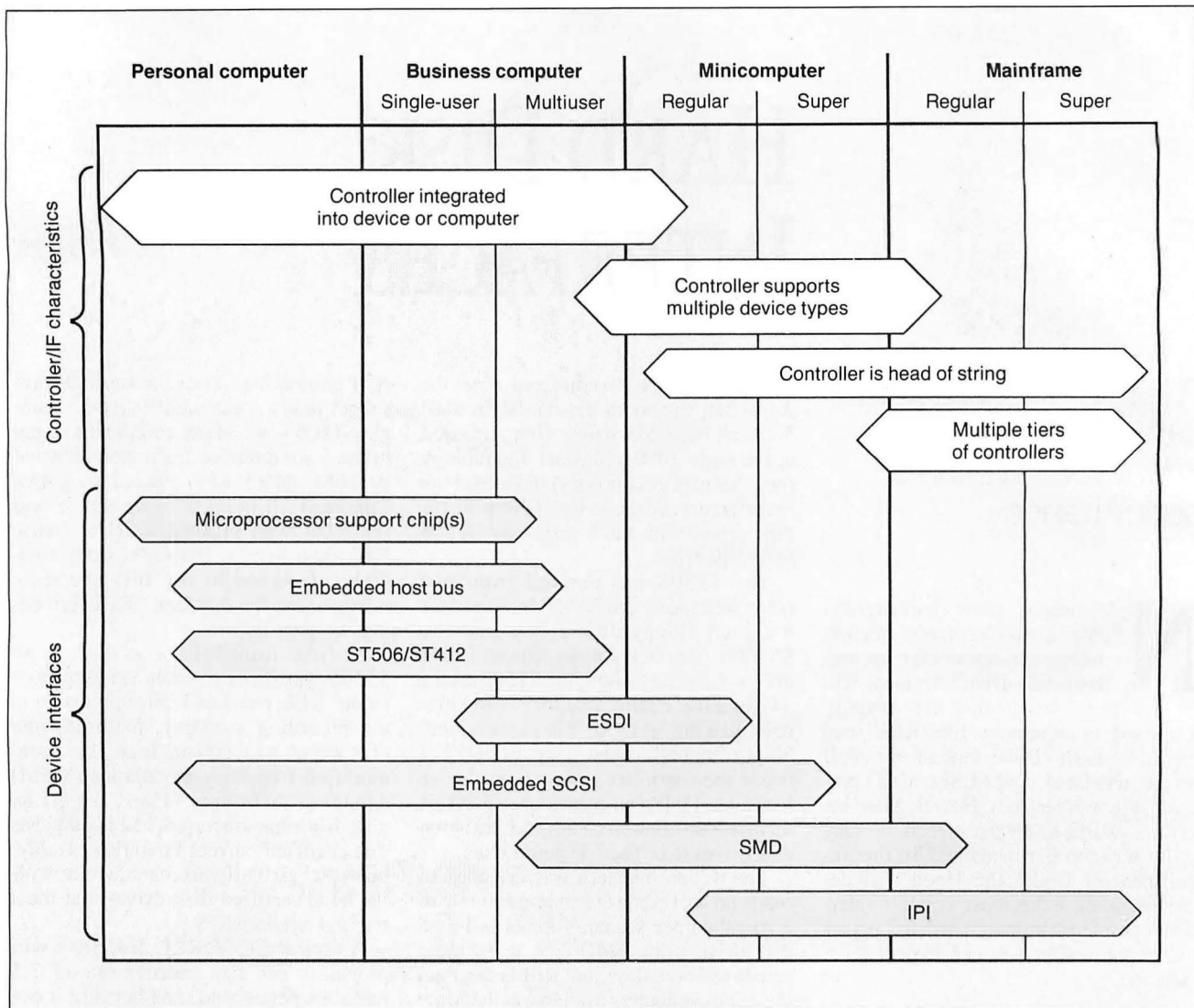

Figure 1: The solution regarding which hard disk drive interface is best suited to your computer depends on your machine's complexity and performance. (Figure courtesy of ENDL Consulting. Used with permission.)

Table 1: A comparison of the cabling, data path widths, ranges, and data transfer rates of a number of popular hard disk drive interfaces. (Table courtesy of ENDL Consulting. Used with permission.)

	Conductors		Data path width (bits)	Distance (meters)	Rep. rate (MHz)	Bit rate (megabits per sec.)	Byte rate (megabytes per sec.)
	Daisy chain	Radial					
ST506/412	34	20	1	3	5	5	0.625
ST506/412/RLL	34	20	1	3	5	7.5	0.9375
ESDI	34	20	1	3	10	10	1.25
SMD	60	26	1	15	14.4	14.4	1.8
SMD-E	60	26	1	15	24	24	3
SASI	50	—	8	3	1.5	12	1.5
SCSI	50	—	8	25	4	32	4
SCSI-2	50+68	—	8+24	25	10	80-320	10-40
IPI-3	50	—	16	125	5	80	10
Enhanced IPI	50/100	—	16+16	>60	12.5	400	50

very sensitive to temperature variations, slight differences in manufacturing tolerances, and cable lengths. Few manufacturers wanted to take the time to certify that their disk drives would work under these conditions.

For these reasons, you may want to think twice before buying an ARLL or ERLI controller. If you want additional speed, consider an ESDI or SCSI disk drive instead.

ESDI

As early as 1983, manufacturers of disk drives and controllers saw a need for a standardized, reliable interface with a greater throughput rate than the ST506. To this end, Maxtor, a hard disk drive manufacturer, initiated the development of the ESDI standard.

While the cables for ESDI are exactly the same size and shape as those for the ST506, ESDI provides a number of new features that greatly enhance performance. It also has provisions for support of optical disks.

What's different about ESDI? Well, the most important change was the move of the data separator (a component that extracts data and clock pulses from the signals received by the head) from the disk drive controller onto the disk drive itself. This change had two main benefits: The signal was not as likely to be degraded in long runs of cable, and the data separator itself could be "tuned" to the characteristics of the disk drive and medium. Because ESDI does not use any analog signals on either cable, it can easily achieve data transfer rates of 10 megabits per second, and it has a theoretical capacity of 24 megabits per second or more.

In ESDI, control signals also are streamlined. While the head can still be stepped a track at a time (as in the ST506), an ESDI controller can also specify the desired track using a binary number. Other ESDI commands can ask for configuration information—for example, whether the drive is a WORM (write once, read many), status (such as whether a removable medium has been changed), or diagnostic tests.

SMD

Control Data Corp. (CDC) developed the SMD interface for large fixed and removable disk drives. Until the introduction of the IPI standard, SMD was the standard interface for disk drives with large capacities and diameters larger than 5 1/4 inches.

Like ESDI, SMD has a data separator on the controller that permits a data

Glossary

ARLL Advanced-run-length-limited encoding; a variant of RLL in which additional speedup techniques are used to squeeze more data onto the disk.

buffered seek A feature that allows a disk drive to accept step pulses—signals that cause the head to move across the disk faster than the head is able to move. The pulses are remembered (buffered), and the head is moved to the desired location as fast as possible.

CAM Common access method; an evolving standard that will let programmers on different computers use the same source code to control SCSI devices.

data separator This device extracts and decodes data and clocking information from the raw signals received by the read/write head of a disk drive.

ERLL Enhanced-run-length-limited encoding. *See* ARLL.

ESDI Enhanced small device interface. This serial device-level interface, designed for disk drives only, improves on the ST506 interface by performing data separation on the drive and allowing the controller to send the drive binary commands over a parallel bus.

FM Frequency modulation. The simplest but least efficient way of encoding disk data, it's virtually never used on hard disk drives. It's called frequency modulation because the pulse rate varies depending on whether the current bit is a 0 or a 1.

IPI Intelligent peripheral interface; a mainframe standard that allows long cable lengths, distributed control, and high data throughput.

MFM Modified frequency modulation. This encoding technique, also called double-density when used on floppy disks, allows twice as much data per track as FM.

repetition rate The maximum frequency at which the data lines of an interface can transmit data bits. Multiplying the repetition rate by the width of the data path yields the data transfer rate of the interface.

RLL Run-length-limited encoding. An extension of MFM, RLL uses a complex scheme to separate pulses still further on the disk and allow for still higher data densities. Most systems described as RLL use 2,7 RLL encoding; a few use 1,7 RLL. (See the text box "RLL Encoding" on page 296.)

SCSI Small computer system interface. This parallel bus standard is designed to interface small computers to disks, tape drives, and other peripherals. It requires intelligence in each peripheral.

SMD Storage module device interface; a venerable mainframe standard that is slowly falling into disuse because of its cost and the emergence of faster interfaces.

ST506 The hard disk drive interface introduced by Seagate in its ST506 5 1/4-inch hard disk drive. This interface has become a de facto industry standard.

step The process of positioning the disk drive head to the chosen location on the disk by moving it incrementally in the desired direction, one notch at a time.

transfer rate of 14.4 megabits per second. A data transfer rate of 24 megabits per second is available on an SMD-E, an enhanced version of SMD. However, because other standards are easier and less expensive to implement, SMD disk drives are not often used on microcomputers. When you do see one on a microcomputer, it is generally in a file server that uses very large disks, like the Fujitsu Eagle.

SCSI

SCSI was developed in the late 1970s as an interface between a computer and an intelligent disk drive controller. Introduced by Shugart Associates as SASI (Shugart Associates system interface), it allowed computers to issue commands and receive data over a simple parallel bus with a byte-wide data path and a relatively small number of control signals.

continued

RLL Encoding

The encoding scheme called run length limited (RLL) is useful for squeezing the largest possible amount of data onto a hard disk drive. To understand how encoding schemes work, let's look at the three most common ones used today: frequency modulation (FM), used on older floppy disk drives, modified frequency modulation (MFM), used on current floppy disk drives and many hard disk drives, and 2,7 RLL (used on most RLL hard disk drives).

Data on a magnetic disk is recorded as a series of pulses and silences. In the FM encoding scheme, each 1 or 0 is represented by a pattern consisting of pulses and silences. For example, a silence followed by a pulse is a 0, and a silence followed by two pulses is a 1. The pulse that's always there is called the clock pulse. Because there is a clock pulse in every bit, it's easy for the controller to keep pace with the data as it comes in (a process known as *clock extraction*).

Figure A shows why this technique is called FM. Twice as many pulses occur per unit of time during a string of 1s than during a string of 0s, and the average (for an even mix of 1s and 0s) is 1.5 pulses per bit.

The constraint that determines how much data you can get on a disk is simple: There must be enough space between pulses so that they don't run together. FM encoding always leaves room for two pulses per bit, in case that bit is a 1. The maximum number of bits you can have, therefore, is always half the maximum number of pulses you can fit in. There is, however, a way to use fewer pulses to represent the same data. This is the idea behind MFM (see figure B).

In MFM, the encoding rule is as follows: A 1 is represented by a silence followed by a pulse, while a 0 is represented by one of two patterns: a pulse

followed by a silence if no pulse occurred at the end of the previous bit, or by two silences if a pulse did occur at the end of the previous bit.

The MFM scheme guarantees that there will always be at least one silence between pulses (so that they can be packed more tightly without running together), but no more than three (so that a clock can still be recovered). This pattern yields an average of 0.75 pulse per bit (assuming that 50 percent of the 0s are represented by each of the two possible patterns), and it therefore lets you

pack the bits twice as closely together. For this reason, when MFM floppy disks first came out, they were called double-density disks.

ST506 hard disk drives originally used MFM encoding. Is there another encoding scheme that could increase the density still further? To answer this question, let's review the schemes just discussed in terms of *run lengths*, the minimum and maximum numbers of consecutive silences in each encoding scheme.

FM allows a minimum run length of

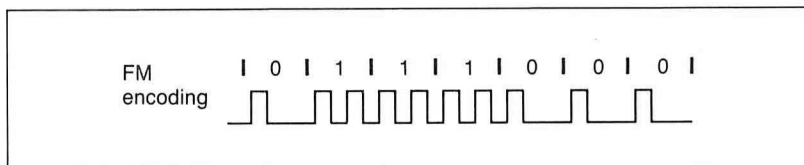

Figure A: In FM encoding, each bit is represented either by a pulse and a silence (0) or by two consecutive pulses (1).

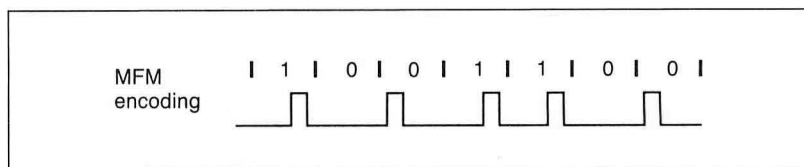

Figure B: In the MFM encoding scheme, all pulses are separated by at least one silence. Since the amount of data that can fit on a disk depends on the closeness of successive pulses, MFM allows twice the data density of FM encoding.

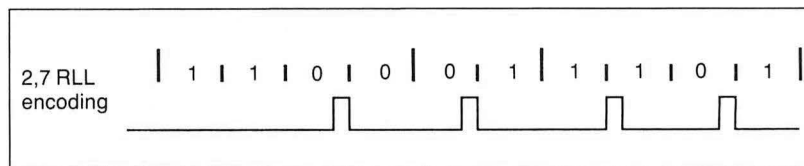

Figure C: Here's how a sample bit pattern is encoded in the 2,7 RLL scheme. Each code group is 4 to 8 half-bits long and is encoded from a code group of 2 to 4 data bits. The length of the pattern corresponds to the length of the original data, but the pulses are guaranteed to maintain the required minimum and maximum spacings.

This scheme had many advantages for computer manufacturers. Rather than having to design controllers for the ST506, SMD, or other disk drive interfaces, the companies could provide one interface—SCSI—and let the user or a systems integrator attach an intelligent controller and a matching disk drive. In theory, a computer that uses a SCSI interface to communicate with its disk drives needs to know little about their

physical or electrical characteristics, and it can often find out what it needs to know by querying the disk drives themselves over the SCSI bus.

This device independence has proved attractive to manufacturers of other kinds of peripherals. You'll see SCSI interfaces on tape drives, floppy disk drives, Bernoulli boxes, portable RAM disks, and even Ethernet controllers. (At least some of the more esoteric SCSI

peripherals were developed because Apple's Macintosh Plus and SE computers have little or no internal expansion capability but do have a SCSI port on the back.) Most disk drive manufacturers now offer products with embedded SCSI controllers, eliminating the need for a controller board between the SCSI bus and the disk drive.

SCSI has evolved and changed greatly over the years. The original SASI inter-

0 (it's possible to have no silences between pulses) and a maximum run length of 1 (there's always a clock pulse after a silence). So, one way to describe FM is as 0,1 run-length-limited encoding, or 0,1 RLL for short.

Similarly, MFM always has at least one silence between the pulses, but no more than three—making it 1,3 RLL. It's the minimum run length that determines how tightly data can be packed onto the disk, while the maximum run length determines how accurate the controller must be at timing when the pulses come in (so that it can generate a clock to go with the data).

The encoding scheme we know simply as RLL is usually 2,7 RLL (see figure C and table A). It uses a more complex set of rules to determine the pulse pattern for each bit based on the values of the preceding bits, but the principle is the same: There are fewer pulses, but their precise positions convey more information about the original data pattern.

Table A: The 2,7 RLL scheme encodes groups of 2 to 4 bits into pulse patterns. Note that there are always at least two, and no more than seven, silences between pulses regardless of the combination of bits encoded.

Data bits to be encoded	2,7 RLL encoding (0 = silence, 1 = pulse)
0 0	1 0 0 0
0 1	0 1 0 0
1 0 0	0 0 1 0 0 0
1 0 1	1 0 0 1 0 0
1 1 0 0	0 0 0 0 1 0 0 0
1 1 0 1	0 0 1 0 0 1 0 0
1 1 1	0 0 0 1 0 0

face transferred data at a maximum rate of 1.5 megabytes per second; enhancements in SCSI allowed synchronous transfers at up to 4 megabytes per second. The SCSI-2 specification, which has already been adopted by many manufacturers and is soon to be an ANSI standard, will allow transfers at up to 10 megabytes per second, and it provides for an optional 16-bit or 32-bit data path for even faster transfers. It also contains

provisions for caching disk drive controllers, printers, communications controllers, CD-ROMs, WORMs, and erasable optical disks.

Using all the capabilities of SCSI-2, it's theoretically possible to transfer data at a blazing speed of 40 megabytes per second—far faster than most microcomputers now available could accept it. Real-life implementations, however, will probably not provide this capability for quite some time.

A thorough description of SCSI could (and, in fact, does) fill several thick volumes. The important thing to note about SCSI is that it supports a far wider variety of devices than any of the interfaces I've mentioned previously—without necessarily imposing a penalty in speed. Given the right hardware and software, a SCSI interface can support not only your disk drives, but also a large number of other peripherals that would otherwise require separate controller cards.

There are some incompatibilities in the command structures used by different machines to talk to different devices, but industry specialists are even now working on a new standard called common access method (CAM) to eliminate these problems. All in all, the future of SCSI looks bright. Perhaps this is why Sun, Apple, and NeXT (among others) have opted to use SCSI as their exclusive interface to hard disk drives.

Intelligent Peripheral Interface

IPI is a standard designed for high-end systems like mainframes from IBM, CDC, and Unisys. Among the features it supports are long cable lengths (up to 125 meters), large numbers of disk drives, and very high data transfer rates (80 megabits per second and above). IPI uses multiple controllers that can be highly intelligent and can hide physical device characteristics.

You're not likely to see IPI on microcomputers in the near future—or maybe ever. But due to its higher speed, it will probably supplant SMD as a standard for large storage devices in the mainframe world.

Choosing an Interface

What does all this mean to you as a user? The vintage ST506 interface, available on the largest number of hard disk drives sold today, can be a bargain. This is especially true if you have a computer like the IBM PC AT, which comes equipped with a controller for these drives. If you currently have an ST506-type controller on your machine, you may wish to move to an RLL controller to squeeze the last

bit of storage out of your drive. This is recommended, however, only if your drive is RLL-certified. (If you buy both a drive and a controller from a competent dealer, the dealer should sell you only an RLL drive with an RLL controller.)

If you're buying a new machine or up-

Ultimately,
*the performance you get
from your disk drive
will depend on more
than just the interface.
Other features may be
more of a factor.*

grading one without a hard disk drive, you should consider ESDI or SCSI—especially if you want top performance. If SCSI is available, you will acquire the possibility of connecting to tape drives and other devices. SMD may be a useful solution if you need to hook up to an existing disk drive with that same interface, but SMD probably is not a good solution if you're going to buy new disk drives.

Ultimately, the performance you get from your disk drive will depend on more than just the interface. Features that may have a far more dramatic effect than the interface alone include the quality of your software, the interleave factor on your disk drive, and the presence or absence of caching. Be sure to take all these factors into account when selecting your hard disk drive system. ■

Special thanks to I. Dal Allen of ENDL Consulting for his help in preparing this article. Also, thanks to Steve Gibson of Gibson Research, who first successfully explained to me how RLL encoding worked.

Brett Glass is a freelance programmer, author, and hardware designer residing in Palo Alto, California. He can be reached on BIX as "glass."

Your questions and comments are welcome. Write to: Editor, BYTE, One Phoenix Mill Lane, Peterborough, NH 03458.

Seven great reasons to join BIX. The on-line service for computing professionals

***Over 200 microcomputer-related conferences:**

Your BIX subscription connects you with experts on Macintosh, IBM PC and compatibles, the Apple II family, Amiga, Atari, and UNIX machines. Join our OS/2 conference and learn about the new presentation manager.

***Microbytes daily – the award winning on-line news service:**

Get up-to-the-minute industry news and new product information covering the IBM, IBM-compatible, Apple Macintosh and workstation markets.

***The full text of BYTE Magazine:**

Each month BIX publishes the complete text of BYTE available on-line before the magazine is printed. Plus each issue since August 1988 is available for searching.

***Vendor support:**

Hundreds of hardware vendors and software publishers use BIX to support their products. Get answers about new releases and tips on how to use products.

***Software libraries:**

Including libraries for PCs, Macs, Apple II, Amiga and Atari. Join the "FromByte" area to get listings from BYTE articles.

***Electronic mail:**

BIX is the only service that offers binary mail attachments. Now you can send spreadsheets, pictures, word processing documents, or desktop publishing files. You can even use BIX mail to distribute software updates.

***New menu interface:**

The new BIX menus provide a convenient map of the system and include powerful options like the BIX Index where you can search all the BIX conferences. The Quick Download option will collect all of your mail messages and new conference messages and send them to you saving valuable on-line time.

What BIX costs: How you pay

One time registration fee: \$39

Hourly Charges:

	Off-Peak	Peak
(Your time of access)	7PM-6AM	6AM-7PM
	\$11	\$20

Charge to Visa, Mastercard, American Express or ask about our corporate billing.

BIX Help Line

800/227-2983

603/924-7681 in New Hampshire

Join BIX right now:

Set your computer's telecommunications program for full duplex, 8-bit characters, no parity, 1 stop bit. Call 800/336-0149 and ask for your local Tymnet number. Dial Tymnet and respond as follows:

Tymnet Prompt:	You Enter
[x] [xx] or terminal identifier	a
login:	bix
name:	new

After you register on-line you get the BIX Main Menu and you can begin to explore the exciting world of BIX.

BIX

One Phoenix Mill Lane, Peterborough, NH 03458 1-800-227-2983 ♦ In NH (603) 924-7681

Display this month's
BIX activities:

F E B R U

SUNDAY, 2/5

Meet the moderators of the Macintosh Conference, 9 PM EST (join macintosh/cbix)

THURSDAY, 2/9

Bantam Books editor Michael L. Roney, on publishing, 9 PM EST (join writers/cbix)

WEDNESDAY, 2/15

Meet BIX director Steve Laliberte, 9 PM EST (join ask.bix/cbix)

THURSDAY, 2/16

Ben Smith, BYTE technical editor, on Unix communications, 9 PM EST (join networks/cbix)

TUESDAY, 2/21

Meet George Bond and Tony Lockwood, BIX executive and managing editors, 9 PM EST (join ask.bix/cbix)

THURSDAY, 2/23

Rick Grehan, BYTE senior technical editor and columnist, on assembly programming, 9 PM EST (join assembler/cbix)

SUNDAY, 2/26

Surprise guest, Macintosh programming whiz, 9 PM EST (join macintosh/cbix)

Continuing C compiler conferences

In addition to our February cbix conferences, there are many continuing conferences you may want to attend via BIX, as well. For example, if reading about C compilers in BYTE's *Product Focus* has you hungering for additional information and insight, you'll want to visit the continuing C Language Conference (join c. language), moderated by Greg Comeau, principal of Comeau Computing, of Richmond Hill, NY. Greg has used machines ranging from micros to mainframes in business and systems programming, and his company produces a Unix shell compiler (CCsh), and a Unix-like command set to MS DOS computers (CCTools).

BIX is also your admission ticket to customer support conferences, conducted by such C compiler vendors as Borland (join borland), Computer Innovations (join computer.innov), Datem (join datem), Lattice (join lattice), Mirco-way (join microway), Mark Williams (join mwc) and Zortech (join zortech).

Chaos Manor conference

Columnist Jerry Pournelle uses his Chaos Manor conference (join chaos.manor) this month to talk about what he found at Comdex. Among his topics are ad-in boards to enhance the Laser Jet; Logic Gem, a program which can generate code in several languages; DESQview 386; WORM drives; the latest version of The Norton Utilities; products from China and Taiwan. He also bids farewell to Zeke, a computer which was his great friend for years. Zeke will retire to the Smithsonian, in Washington, D.C., as a mile-post in the history of computing.

Only BIX subscribers may attend BIX conferences. Our ad on the adjoining page will tell you how you can subscribe.

BIX

One Phoenix Mill Lane ♦ Peterborough, NH 03458
1-800-227-2983 ♦ In NH (603) 924-7681

HELP THE AMERICAN FOUNDATION FOR THE BLIND HELP YOU!

The American Foundation for the Blind's National Technology Center (NTC) maintains a Job Index/User Network which features information from over 1,100 blind and visually impaired people who use adaptive equipment in a variety of jobs.

The NTC is looking for additional participants. Blind and visually impaired individuals of all ages who have hands-on experience with computers, low vision aids, talking products, or other adaptive devices are needed as resource people and/or evaluators.

As a resource person, other users may contact you to share your knowledge and experience. As an evaluator, you may be asked to evaluate both existing and newly developed or adapted devices. Evaluations are published in the "Random Access" section of the *Journal of Visual Impairment & Blindness*.

If you are interested, please fill out the form below or call our hotline, 1-800-232-5463 (New York residents call 212-620-2147). Tell the operator you wish to be part of the Job Index/User Network.

Your response will be followed by a brief, confidential telephone survey. The information you provide will be used for NTC purposes only and will include the equipment you use, your experience with it, training and employment.

Your assistance will enable the Job Index/User Network to continue as a major information and support system for blind and visually impaired people nationwide.

Mail to: American Foundation for the Blind, National Technology Center, 15 West 16th Street, New York, NY 10011, Attn: A. Hypolite

Name _____

Address _____

City _____ State _____ Zip _____

Best time to contact _____ Telephone _____

Part 2

TREES 'N KEYS



Now that we have the keys, let's look at the data in our keyed file system

Last month I introduced the B-tree as a data structure well-suited to the manipulation of keyed file systems. Some readers may already recognize the structure as the basis of what are referred to as ISAM (indexed-sequential access method) file systems. Indeed, with the routines I've presented so far, you can access data in indexed fashion (the `SEEK_KEY` routine) or in sequential fashion (the `SEEK_NEXT_KEY` routine). The culmination of this three-part series will be an ISAM system that I call ZSAM (because I did a lot of the original development of it on ZDOS, Zenith's version of MS-DOS). ZSAM is a collection of assembly language routines callable from Turbo C.

This month I'll finish describing the key-file side of the system and move on to examining the data file—in many ways, the real meat.

Messy, but Necessary

Some databases may never need a `DELETE_KEY` routine. A good example would be a library catalog system: Entries are searched for or added, but never removed. Unfortunately, not all databases are add-only; customers join and resign, students graduate, and accounts payable transactions are posted at year's end. The pseudocode for the `DELETE_KEY` routine, which handles the job of key removal, is in listing 1.

Deleting a key assumes that the key is in the tree. So, `DELETE_KEY` begins by calling `SEEK_KEY` to verify the target's existence and set the roving pointer. Next, `DELETE_KEY` determines

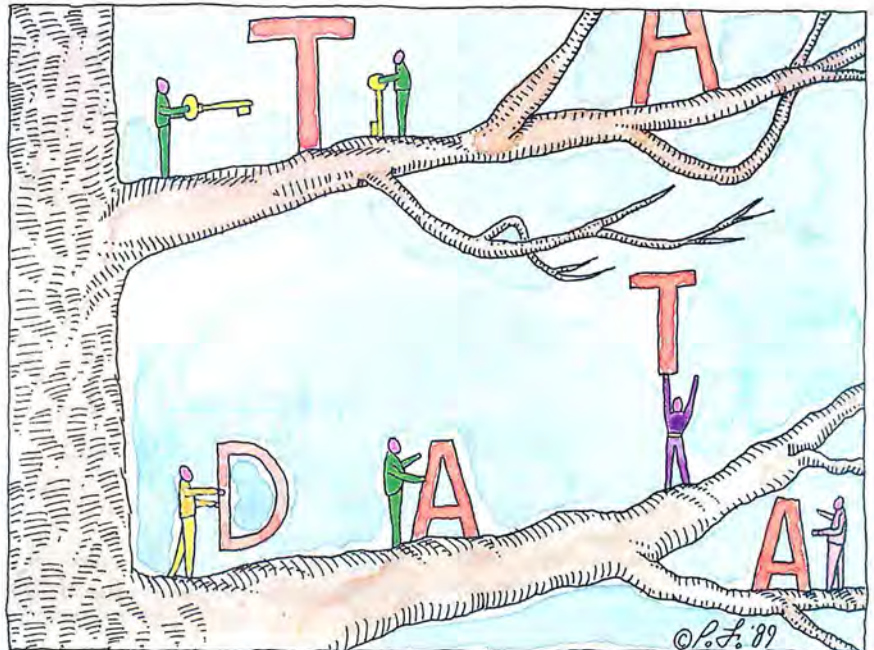

whether the key is on a leaf node (NULL key-node pointers imply that it's a leaf) and, if so, simply collapses the node at the target site. The keys to the right of the target slide one position to the left, overwriting the deleted key. Then the node's keycount is decremented.

However, the key may not be on a leaf; in this case, collapsing the node won't work because the deleted key is flanked by two key-node pointers that would need to be merged somehow into one. So, `DELETE_KEY` locates the target key's inorder successor, overwrites the target with its successor key, and loops back into itself to remove the successor key from the node it was originally on. This preserves the relationship among the keys in the B-tree. As you can see in listing 1, `DELETE_KEY` uses `SEEK_NEXT_KEY` (which I described last month) to find the inorder successor. (A key's inorder successor will always be on a leaf node. You might want to sketch a few B-trees to convince yourself of this.)

As keys are deleted from a node, that node becomes emptier and emptier until it's deleted right out of existence. Some sort of maintenance has to go on inside of `DELETE_KEY`, or a B-tree that's had lots of keys deleted from it could end up with nearly empty nodes scattered throughout. This fragmentation degrades performance since the software wastes time reading nearly empty nodes from disk. To combat this, the `DELETE_KEY` routine uses a scheme to merge nodes whenever possible. When `DELETE_KEY` removes a key from a node, it checks the node's adjacent siblings to see if two less-than-full nodes can be combined. This process is described in more detail in the text box "Combating Empty Nodes" on page 302.

Finally, `DELETE_KEY` always exits via a call to `SEEK_KEY`. As with last month's `CREATE_KEY` routine, this is necessary to keep the roving pointer and the pseudostack intact. Of course, the

continued

Combating Empty Nodes

Though I could sling a lot of mathematics around to prove it, just plain common sense should tell you that a B-tree's performance will suffer if its nodes are kept less than full. The system has to read nodes in from the disk; therefore, if you keep those nodes as full as possible, the software can get more work done per disk read. (Disk access is certainly the speed bottleneck of the system.)

Two actions contribute to "node emptying" in the B-tree. First and most obvious is deleting a key. You can combat this by *merging* nodes, as illustrated in figure A.

In the first part of the figure, a key has just been deleted from a node, leaving only one key—Gail—left on that node. The software checks that node's sibling and discovers that the right sibling holds only two keys. Since this is an order-4 B-tree, the original node, the father key, and the right sibling can be combined into a single node, as shown in figure A2.

Notice that since the key Hank has migrated down the tree, Kelly is now left alone on a node. If Kelly has siblings, the software can attempt to merge nodes on that level, and the process can continue up the tree all the way to the root, if necessary. (As you may have noticed, merging is simply the reverse of

the splitting process that CREATE_KEY used.)

Splitting a node also causes nodes to become more empty, since after a split at least two nodes will be half empty. You can defer splitting a node until it becomes absolutely necessary by using *local rotation*, as in figure B. In the first part of the figure, the key Henry has

been inserted, causing that node to become over-full. Instead of splitting the node, however, the software can examine that node's siblings to see if they're full. In the second part of the figure, the software has determined that the node's right sibling can hold an extra key and so rotates a key through the father and into the sibling.

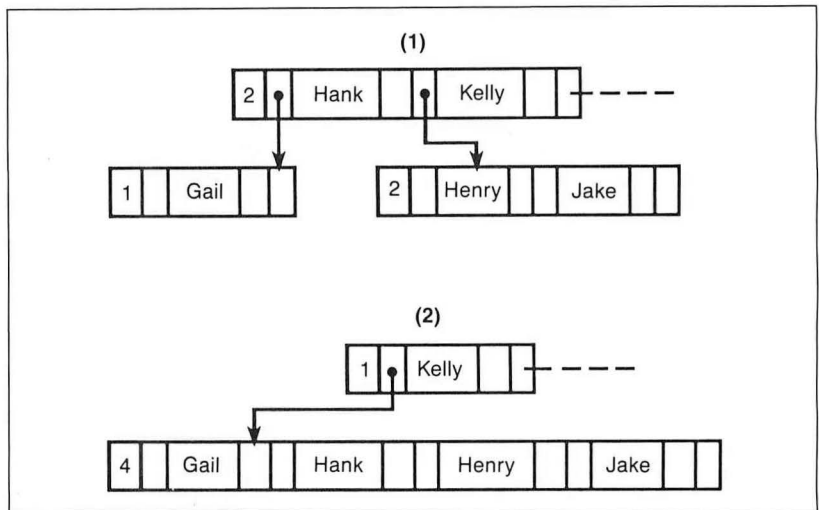

Figure A: A sample order-4 B-tree. (1) A key has been deleted, leaving Gail all alone on its node. (2) Merging Gail with the father key and right sibling reduces two near-empty nodes to a single full node. Of course, the node containing Kelly might now be merged with its sibling.

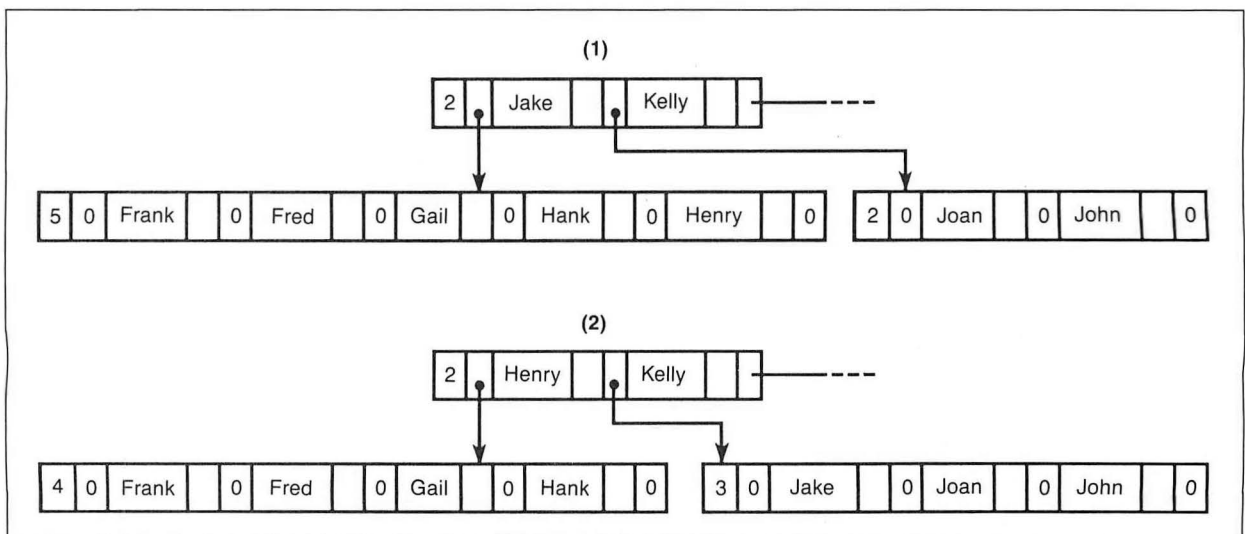

Figure B: Inserting Henry in this order-4 B-tree (1) causes a node to become over-full and in need of splitting. Splitting can be avoided (2) if the overflow is allowed to spill into a less-than-full sibling through the father. Notice that if the overflowed node had not been a leaf, then Henry's rightmost key-node pointer in the first part of the figure would become Jake's leftmost key-node pointer in part 2.

key that SEEK_KEY is looking for has been deleted, so DELETE_KEY clears the error code that SEEK_KEY has set. Thus, you can perform a SEEK_NEXT_KEY immediately after a DELETE_KEY and get the result you'd expect: That is, SEEK_NEXT_KEY will return the inorder successor of the key just deleted.

The Data

Though I've spent a great deal of time discussing searching for keys, the true destination of a search is the data. The keys merely serve as mnemonics, pointing to the information in the data file that you were trying to get to in the first place.

Typically, you find that the contents of a database are easily grouped into categories—attributes, if you wish—that the database associates with each entry. So, for example, each entry in a customer list would include the name, address, phone number, and current balance. All entries have the same structure, and this makes it easy to construct the data-file side of the database as a set of records of constant size.

The first type of data file that ZSAM supports is accessed as a set of fixed-length records, one record to each key. I'll refer to this kind of data file as a *simple* data file, thanks to its easy-to-understand structure. Conceptually, it's just like the sample keyed file system I showed in figure 1 of last month's column. Handling simple data files is... well... simple, and I won't go into it in detail. Whenever the system needs to attach a simple data record to a key, it records that record's offset in the data pointer associated with the correct key. Deleting simple data records is also simple.

However, some databases may not fit well into a one-record-per-key format. What if your database is running in a video rental parlor? You'll want to be able to place multiple records in a client's account to allow customers to rent an arbitrary number of videotapes at any given time. One solution would be to create a keyed-record entry for each tape the customer rents, but this adds keys to the key file, where they're not really needed. Another solution would be to allow records to vary in size, but this turns handling deleted records into a nightmare; essentially, you'd be dealing with a disk-based heap.

ZSAM supports a second kind of data file that I'll refer to as a *complex* data file. A complex data file allows a single

continued

Listing 1: *The pseudocode for the DELETE_KEY routine.*

```
{ Delete CURRENT_KEY.
DELETE_KEY:
  SEEK_KEY(CURRENT_KEY);
  IF key not found THEN
    RETURN key-not-found error;
  { We do the following so that, after the key is deleted, the system can
  { call DELETE_RECORD_SET to delete the associated data record.
  Load CURRENT_DATA_PTR;
LO:
  IF key at KEYOFFSET's left or right key-node pointer is 0 THEN
    BEGIN { The key is on a leaf.}
      NEW_NODE = bitwise OR of left key-node pointer and right
              key-node pointer;
    L1:
      Left key-node pointer {at KEYOFFSET} = NEW_NODE;
      Set left key-node pointer {at KEYOFFSET} to bitwise or of left key-
              node pointer and right key-node pointer;
      TEMP = left key-node pointer;
      Copy contents of key node starting at KEYOFFSET+1 to the left 1
              key position {overwriting target key};
      Decrement node's KEYCOUNT by 1;
      IF KEYCOUNT = 0 THEN
        { The entire node has been deleted. The TEMP holds what may
        { be the node's only child. Pop the pseudostack for the node's
        { father and overwrite to pointer to the dead node with TEMP.
        BEGIN
          POP(CURRENT_KEY_SECTOR,KEYOFFSET);
          IF POP() FAILED THEN
            ROOT=TEMP;
          ELSE
            { Put the key pointer in the deleted node's father.
            BEGIN
              GET(CURRENT_KEY_SECTOR);
              Key-node pointer at KEYOFFSET = TEMP;
              PUT(CURRENT_KEY_SECTOR);
            END
            CALL SEEK_KEY;
            RETURN no error;
          END
          { At this point, not all keys were removed from the node. See if the
          { node can be merged with one of its siblings.
          TEMP_COUNT = current node's KEYCOUNT;
          PUT(CURRENT_KEY_SECTOR);
          POP(POP_NODE,POP_OFFSET);
          IF POP() failed THEN {Can't pop? At root.}
            BEGIN
              CALL SEEK_KEY;
              RETURN no error;
            END
            GET(POP_NODE);
            { Put the father node in WORKING_KEY buffer.
            Move KEY_NODE[] to WORKING_KEY buffer;
            MAXKEYS = maximum number of keys allowed on a node;
            SIBLING_NODE = NULL;
            IF TEMP_COUNT + left sibling's KEYCOUNT + 1 <=
                    MAXKEYS THEN
              SIBLING_NODE = left sibling;
            ELSE
              IF TEMP_COUNT + right sibling's KEYCOUNT +
                    1 <= MAXKEYS THEN
                SIBLING_NODE = right sibling;
            IF SIBLING_NODE NOT = NULL THEN
              BEGIN {Do a merge}
                GET(CURRENT_KEY_SECTOR);
                Attach key at POP_OFFSET from WORKING_KEY buffer to
                    end of KEY_NODE[];
```

continued

```

Attach keys on SIBLING_NODE to end of KEY_NODE[];
Update current node's keycount;
PUT(CURRENT_KEY_SECTOR);
NEW_NODE = CURRENT_KEY_SECTOR;
Put SIBLING_NODE on available-for-use list;
Move WORKING_KEY buffer to KEY_NODE[];
CURRENT_KEY_SECTOR = POP_NODE;
CURRENT_KEY_OFFSET = POP_OFFSET;
GOTO L1; { Remove father key and repeat.}
END
END
ELSE {Flanking key-node pointers are not empty.}
BEGIN
Copy KEY_NODE[] to WORKING_KEY buffer;
TEMP = CURRENT_KEY_SECTOR;
{ The following call will leave the successor key's node in the
{ KEY_NODE[] buffer.
CALL SEEK_NEXT_KEY;
Copy successor key over target key;
Swap KEY_NODE[] and WORKING_KEY buffer;
PUT(TEMP);
Swap KEY_NODE[] and WORKING_KEY buffer;
{ Now the target's inorder successor is removed from its original
{ node via a reentry into the delete routine.
GOTO L0;
END

```

The records' forward and backward links allow for easy maneuvering through the record set. This should become apparent as you examine the routines that follow.

Doing It Complex

Getting to the start of a record set is easy. Any routine that would read a record in a simple data file (e.g., SEEK_KEY, SEEK_NEXT_KEY, or CREATE_

Any routine that would read a record in a simple data file retrieves a pointer to the first record of the record set in a complex data file.

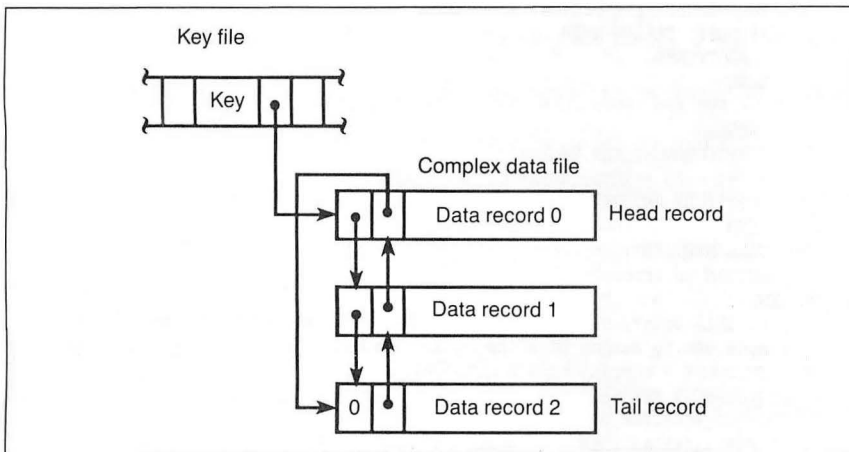

Figure 1: A complex data file allows a single key to reference a record set—a doubly linked list of an arbitrary number of records.

key to point to a list of records. So, the data record pointer in a keyed file points to the head of a doubly linked list of records in a complex data file; I'll refer to such a list as a *record set*. The structure of a record set is shown in figure 1.

The data pointer in the keyed file points to the first record (the *head record*) in the record set. Each member of the set has two pointers prefixed: a forward link, which points to the next record in the set, and a backward link, which points to the previous record in the set. As with simple data files, all records in a complex data file are of the same length. This makes managing deleted records easy, since deleting or reusing a

deleted record requires only that you manipulate pointers. But since there's no real limit to the number of records that can be in a record set, you can attach arbitrarily long hunks of data to a single key.

A new record added to a record set is attached to the tail (the new record becomes the new tail), so you'll need to be able to find the record set's tail as soon as you access the set. Notice that the backward link of the head record points to the tail, so that when the system performs a SEEK_KEY and retrieves the key and its associated data pointer to the record set head, only one additional access is needed to get to the tail.

KEY) retrieves a pointer to the first record of the record set in a complex data file. Furthermore, those routines load a set of internal pointers that keep track of where you are in the record set, where the head of the record set is, and where the tail is. You'll see the importance of these pointers in a moment. (Though I didn't express this explicitly in last month's pseudocode, the ZSAM routines do handle the internal pointers as I've described here.)

Once you're at the head of the set, you'll want to be able to access the records in sequential order. You do this with a call to READ_NEXT_RECORD (see listing 2), which simply follows the forward pointer chain. If, in the process of reading through the record set, you attempt to read past the tail, READ_NEXT_RECORD returns an appropriate error code.

Some algorithms may require you to reset the internal pointers to the head of the current record set. You would accomplish this with REWIND_SET (see listing 3), which is a lot like the REWIND routine that I described last month; if you call READ_NEXT_RECORD after REWIND_SET, the routine will return the first record in the set. Notice that REWIND_SET simply loads the CURRENT_DATA_PTR with the head

The best Modula-2

compilers for PCs and
compatibles

Taylor Modula-2

The professional high-performance compiler for PCs: the fastest compiler in the world!

- * **unrivalled speed of compilation**
7,000-10,000 lines per minute (80286, 8 MHz).
- * **excellent code**
Mini-computer standard global optimisation. Code performs 1580 Dhrystone tests per second! (80286, 8 MHz)
- * **ultra-compact**
high code density and a library of unrivalled compactness (23 modules in a total of 13Ki)
- * **completely standard implementation**
Follows N. Wirth's standard for Modula-2. BIOS independent - uses MS/PC DOS exclusively.
- * **easy to use**
Straightforward user interface. Comprehensive documentation for system programmers.
- * **Guarantee and support**
One year guarantee. Maintenance contracts available. Swiss quality product.

TaylorModula-2 \$ 900
Demo disk \$ 10

M2SDS \$ 99

The professional Modula-2 software development system M2SDS comprises the following features in an easy-to-use window environment:

- modern, syntax-driven editor
- fast compiler
- linker producing EXE programs
- unique library manager
- comprehensive standard library

There are a vast number of tools, toolboxes, demo disks, public domain programs and books for M2SDS - probably more than for any other development system! M2SDS was used for the writing of the Farsight integrated business software package!

Demo disks \$ 10

JPI-Modula-2 \$ 149

A reasonably-priced Modula-2 compiler with a configurable environment, integrated Make function and highly optimising code generator.

We have Modula-2 compilers for the Amiga, HP9000/300, IBM/370, OS-9 and Sun. The list is constantly growing!

Texas residents add 6% sales tax. International Orders add \$ 20 shipping.

The Modula-2 people:



3336 Richmond, Suite 323
Houston, TX 77098-9990 (713) 523 8422

Dealer inquiries welcome

International	
Austria: 0222/4545010	United Kingdom: 01/6567333
Belgium: 071/366133	Germany: 02983/8337;
France: 20822662	0731/26932;
Italy: 02/405174	0821/85737;
Scandinavia: +45/3/512014	04106/3998;
Switzerland: 01/9455432	0531/347121

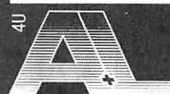

A. + L. Meier-Vogt
Im Späten 23
CH-8906 Bonstetten/ZH
Switzerland
Tel. (41)(1) 700 30 37

record's number.

As I mentioned before, new records added to a record set are always appended to the tail; records in a record set are not sorted (and they shouldn't be; if you want records sorted, you should give

each one a key and use a simple data file). APPEND_RECORD (see listing 4) adds a new record to the current record set; the appended record becomes the new tail. (If you're wondering how RE-

continued

Listing 2: The READ_NEXT_RECORD routine provides sequential access of the elements in a data record set.

```
{ This routine reads the next data record in a record set.
READ_NEXT_RECORD:
  IF data file is not complex THEN
    RETURN data file not complex error;
  IF CURRENT_DATA_PTR invalid THEN
    RETURN data pointer invalid error;
  { If DFLAG = 1 then we are "between" records. This happens if we've just
  { deleted a record; fortunately, CURRENT_DATA_PTR is set to the
  { deleted record's forward link, so all we have to do is clear DFLAG.
  IF DFLAG = 1 THEN
    BEGIN
      DFLAG=0;
      GET(CURRENT_DATA_PTR);
      RETURN contents of data record;
    END
  IF forward link = 0 THEN { We are at the tail.}
    RETURN end of record set error;
  CURRENT_DATA_PTR = forward link;
  GET(CURRENT_DATA_PTR);
  Load forward and backward links of CURRENT_DATA_PTR;
  RETURN contents of data record;
```

Listing 3: REWIND_SET sets internal pointers back to a record set's logical start so that a subsequent call to READ_NEXT_RECORD will return the record set's head record.

```
{ Move to the head record of a record set.
REWIND_SET:
  IF data file is not complex THEN
    RETURN data file not complex error;
  CURRENT_DATA_PTR = head record;
  RETURN;
```

Listing 4: APPEND_RECORD adds a new record to a record set.

```
{ This routine appends a new data record to the current record set.
{ The information to be placed in the record is in RECSTRING.
APPEND_RECORD:
  IF data file is not complex THEN
    RETURN data file not complex error;
  { GET_NEW_RECORD() returns a pointer to an empty,
  { ready-for-use record.
  NEW_PTR = GET_NEW_RECORD();
  HEAD_PTR = Head record number; {of current set}
  TAIL_PTR = Tail record number; {of current set}
  Forward link of NEW_PTR = 0;
  Backward link of NEW_PTR = TAIL_PTR;
  Copy contents of RECSTRING into NEW_PTR's data area;
  PUT(NEW_PTR); { Write the new record to disk.}
  Backward pointer of HEAD_PTR = NEW_PTR;
  Forward pointer of TAIL_PTR = NEW_PTR;
  RETURN;
```

A MESSAGE TO OUR SUBSCRIBERS

FROM TIME TO TIME we make the BYTE subscriber list available to other companies who wish to send our subscribers material about their products. We take great care to screen these companies, choosing only those who are reputable, and whose products, services, or information we feel would be of interest to you. Direct mail is an efficient medium for presenting the latest personal computer goods and services to our subscribers.

Many BYTE subscribers appreciate this controlled use of our mailing list, and look forward to finding information of interest to them in the mail. Used are our subscribers' names and addresses only (no other information we may have is ever given).

While we believe the distribution of this information is of benefit to our subscribers, we firmly respect the wishes of any subscriber who does not want to receive such promotional literature. Should you wish to restrict the use of your name, simply send your request to the following address.

BYTE MAGAZINE
ATTN: SUBSCRIBER SERVICE
P.O. Box 7643
TEANECK, NJ 07666-9866



Listing 5: The pseudocode for DELETE_RECORD_SET.

```
{ This routine puts an entire record set on the available-for-reuse
{ list. This list is pointed to by DAV.
DELETE_RECORD_SET:
  HEAD_PTR = Head record number;
  TAIL_PTR = Tail record number;
  Forward link of TAIL_PTR = DAV;
  DAV = HEAD_PTR;
  RETURN;
```

(a)

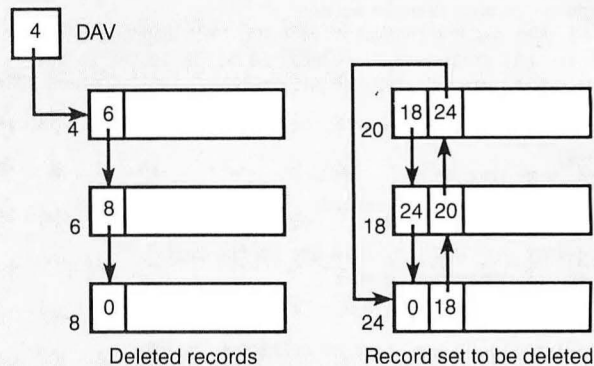

(b)

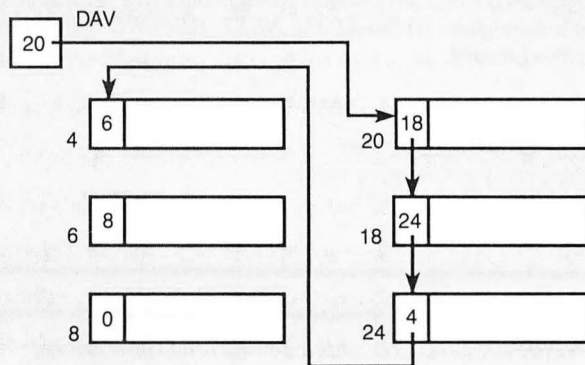

Figure 2: Once *DELETE_KEY* has removed the associated key, deleting an entire record set is simply a matter of attaching the set to the available-for-reuse list.

(a) Before deleting, *DAV* points to the first member of the available-for-reuse list.

(b) After deleting, *DAV* is set to the head record of the set, and the forward link of the tail holds *DAV*'s old contents. The backward links are now superfluous.

WIND_SET and *APPEND_RECORD* knew the location of the head and tail records, remember that I said the *ZSAM* routines that initially access a record set store pointers to the head and tail internally.)

Deleting members of a record set is slightly more complex than deleting simple records. It involves manipulating

pointers to keep the list intact (deleting an entire set is easy; see figure 2 and listing 5). Follow these steps (you might want to draw this process out on paper), and you won't get confused:

1. Copy the deleted record's forward pointer into the forward pointer of the previous record.

Listing 6: DELETE_RECORD removes a record from a record set.

```
{ This routine deletes a data record from a record set.
DELETE_RECORD:
  IF data file is not complex THEN
    RETURN data file not complex error;
  IF CURRENT_DATA_PTR invalid THEN
    RETURN data pointer invalid error;
  IF CURRENT_DATA_PTR points to head record THEN
    { We are deleting the head record. See if the head record is also the
    { tail record and, if so, delete the entire record set.
  IF CURRENT_DATA_PTR points to tail record THEN
    BEGIN
      CALL DELETE_RECORD_SET;
      RETURN record set deleted error;
    END
  ELSE
    BEGIN
      TEMP_PTR = CURRENT_DATA_PTR's forward link.
      Copy contents of TEMP_PTR's data record into
      CURRENT_DATA_PTR's data record.
    END
  ELSE
    BEGIN
      TEMP_PTR = CURRENT_DATA_PTR's forward link;
    END
  { At this point, we've determined we are not deleting the head record.
  PREV_REC = CURRENT_DATA_PTR's backward link;
  NEXT_REC = CURRENT_DATA_PTR's forward link;
  Set PREV_REC's forward link to NEXT_REC;
  Set NEXT_REC's backward link to PREV_REC;
  Put CURRENT_DATA_PTR on available-for-reuse list;
  CURRENT_DATA_PTR=TEMP_PTR;
  DFLAG=1; {Show that we are between records.}
  RETURN;
```

2. Copy the deleted record's backward pointer into the next record's backward pointer.

The record is now out of the chain and can be moved onto the list of records available for reuse.

What happens when you delete the head of a record set? The head is what the data pointer in the key file is aimed at; if you delete the head, won't that data pointer now be pointing off to a dead record?

Well, it won't if you don't *physically* delete the first record, and you can pull off this dodge by copying the contents of the second record on top of the contents of the head, then physically deleting the second record. The pseudocode for DELETE_RECORD is in listing 6.

We Have the Technology . . .

Actually, the doubly linked list structure of the record set allows for more routines than I've shown here. You might want to add a READ_PREVIOUS_RECORD routine that moves "up" the record set by following the backward links. And once you've got that, surely you'll want a function called UNREWIND_SET,

which moves the internal pointers to the tail record.

Though I cannot think of any uses for those routines, that doesn't mean that uses are not out there, and it would certainly make the complex data-file handling routines more plenary.

Next Month

I'll put everything together with ZSAM, a B-tree keyed file system based on the routines I've presented. ZSAM is written in 8088 assembly language interfaced to Borland's Turbo C. I'll also give a sample real-life application for ZSAM. ■

Author's note: *The source code for ZSAM will be available as of next month. Look for details in the March column.*

Rick Grehan is a BYTE senior technical editor at large. He has a BS in physics and applied mathematics and an MS in computer science/mathematics from Memphis State University. He can be reached on BIX as "rick_g."

Your questions and comments are welcome. Write to: Editor, BYTE, One Phoenix Mill Lane, Peterborough, NH 03458.

Tools and Toolboxes
Modula-2

Applications Generator

Amadeus \$ 395
Generate Modula-2 programs directly from your own input, and save yourself hours of coding!

Graphics

M2Graph* \$ 65
Controls Hercules cards in Modula-2.

M2EGA* \$ 65
Controls EGA cards in Modula-2.

Modula Graphics Toolbox I* \$ 112
A collection of extremely fast graphics routines for CGA cards written in Modula-2.

Modula Graphics Toolbox II* \$ 188
Comprehensive package of Modula-2 procedures for all currently available graphics cards. Includes graphics window system, font generator, sprite handler, mouse driver, maths routines, as well as pie chart, histogram and line graph functions etc.

Input/Output

LCR-Window Manager* \$ 133
Fast, compact window system.

M2Windows* \$ 188
Fast, professional window system. Small, high-performance library with integrated menu system and simple mask generator.

Modula Mask & Menu Generator* \$ 360
Development system for creating masks and menus in Modula-2 source code. Mask, menu and frame editor. Supports all colours and attributes.

Other Tools

M2 Prolib \$ 495
The professional library

B-Tree ISAM \$ 290
Ultra fast database

Pascal-Modula Converter \$ 59
Converts Turbo-Pascal to Modula-2.

RTA-Utility Disk \$ 30
2-10x faster I/O, extended MathLib.

EMS-Utilities* \$ 188
Make full use of your Megabytes of memory expansion.

M2IEEE-Interface* \$ 144
Modula-2 interface to National Instruments IEEE Interface.

This is only a small selection from our comprehensive list of tools for Modula-2. Demo disks are available for products marked with an asterisk. Send \$ 10 for three demo disks, \$ 20 for seven. There is also a wide choice of books and literature on Modula-2.

We have Modula-2 compilers for the Amiga, HP-UX, IBM 370, PCs (Eaton, M2SOS, M21), OS-9 and Sun. The list is constantly growing!

The Modula-2 people:



3336 Richmond, Suite 323
Houston, TX 77098-9990 (713) 523 8422

Dealer inquiries welcome

International	
Austria: 0222/4545010	United Kingdom: 01/6567333
Belgium: 071/366133	Germany: 02983/8337
France: 20822662	0731/26932
Italy: 02/405174	0821/85737
Scandinavia: +45/3/512014	04106/3998
Switzerland: 01/9455432	0531/347121



A. + L. Meier-Vogt
Im Späten 23
CH-8906 Bonstetten/ZH
Switzerland
Tel. (41)(1) 700 30 37

THE BUYER'S MART

A Directory of Products and Services

THE BUYER'S MART is a monthly advertising section which enables readers to easily locate suppliers by product category. As a unique feature, each BUYER'S MART ad includes a Reader Service number to assist interested readers in requesting information from participating advertisers.

RATES: 1x—\$525 3x—\$500 6x—\$475 12x—\$425
Prepayment must accompany each insertion. VISA/MC Accepted.

AD FORMAT: Each ad will be designed and typeset by BYTE. Advertisers must

furnish typewritten copy. Ads can include headline (23 characters maximum), descriptive text (250 characters is recommended, but up to 350 characters can be accommodated), plus company name, address and telephone number. Do not send logos or camera-ready artwork.

DEADLINE: Ad copy is due approximately 2 months prior to issue date. For example: November issue closes on September 8. Send your copy and payment to THE BUYER'S MART, BYTE Magazine, 1 Phoenix Mill Lane, Peterborough, NH 03458. For more information call 603-924-3754.

ACCESSORIES

CUT RIBBON COSTS!

Re-ink your printer ribbons quickly and easily. Do all cartridge ribbons with just one inker! For crisp, black professional print since 1982. You can choose from 3 models: Manual E-Zee Inker — \$39.50
Electric E-Zee Inker — \$89.50
Ink Master (Electric) — \$159.00

1000's of satisfied users in 5 years. Money back guarantee.

BORG INDUSTRIES

525 MAIN ST., JANESVILLE, IA 50647
1-800-553-2404 In IOWA 319-987-2976

Inquiry 576.

ARTIFICIAL INTELLIGENCE

NEW EXPERT SYSTEM

FirstExpert - A unique expert systems tool that you can master in a few hours! Generates the complete system based on your specification! Built-in learning procedure automatically creates knowledgebase. Interactive structured induction allows you to add new knowledge at any time. Includes consultancy system. Handles up to 10,000 rules on a PC! Demos included! IBM pc's /IPS-2's.

An ingenious program, buy now for only \$99.95. \$/h add \$500

NovaCast Expert Systems

2530 Berryessa Rd. Suite 607, San Jose, CA 95132
(408) 272-4071 Fax: (408) 437-7777

Inquiry 580.

BAR CODE

PRINT BAR CODES/BIG TEXT FROM YOUR PROGRAM

Add bar codes and big graphics text to your program. Print from ANY MS-DOS language. Bar codes: UPC, EAN, 2 of 5, MSI, Code 39, Epson, OKI, IBM dot matrix text up to 1/2". LaserJet up to 2". Font cartridges not required. \$159-\$239. 30 day \$\$ back.

Worthington Data Solutions

417-A Ingalls St., Santa Cruz, CA 95060
(800) 345-4220 In CA: (408) 458-9938

SELF-INKING PRINTER RIBBON

Awarded United States Patent #4701062
Lasts 10-15 times longer than the conventional ribbon.
For printers using 1/2" width open spool ribbon:
Okidata-82A-83A-84-92-93 Dec LA 180/120
Teletype-33, 35 Dec LA 301BM 1443
Star Gemini 10X Teletype-Model 40
Extel TI 800/810, 820, 880

Contact us by mail, phone or telex and we will forward you a brochure.

CONTROLLED PRINTOUT DEVICES, INC.

POB 869, Baldwin Rd., Arden, NC 28704
(704) 684-9044 • TELEX: (FILMON-AREN) 577454

Inquiry 577.

Buy your own Book

Get a fully supported LISP program for the MAC without the padded price to pay for an expensive book. \$20 buys it MAC plus or equivalent runs it. Order now and save.

Oosson Software

Box 33113, Coon Rapids, MN 55433

Inquiry 581.

COMPLETE LINE OF BAR CODE PRODUCTS

- PrintBar II • PrintBar Softfonts
- PrintBar I • CodeScan 2000

FREE BROCHURES (916) 622-4640

Bear Rock Software Co.

6069 Enterprise Dr. Placerville, CA 95667

Inquiry 583.

ARTIFICIAL INTELLIGENCE

EXPERT SYSTEM DEVELOPMENT

Get the award winning AGNESS to develop network based expert systems using multiple inference methods, the Merit scheme for efficient data collection, and unique explanation facilities. Use the AGNESS C_talk Toolkit to embed an expert system into your application under an object oriented environment. \$795.

Applied Information Systems, Inc.

2117 West Hoyt Ave., St. Paul, MN 55108

(612) 641-9947

Inquiry 578.

muLISP™ 87 for MS-DOS

Fast, compact, efficient LISP programming environment. muLISP programs run 2 to 3 times faster & take 1/2 to 1/3 the space of other LISPs. 450 Common LISP functions, multi-window editing & debugging, flavors, graphics primitives, lessons & help, demo programs, comprehensive manual.

Soft Warehouse, Inc.

3615 Harding Ave., Suite 505, Honolulu, HI 96816

(808) 734-5801

Inquiry 582.

BAR CODE SOLUTIONS

We make bar coding very easy with our complete line of readers. Our PC-Wand readers network, or work with your keyboard or terminal, or are carried around taking inventory, entering sales and clocking time. Our bar code label printing software packages work with MS-DOS or PC-DOS and most matrix or laser printers. We also sell pre-printed labels. Our hardware can work with nearly every computer in the world.

International Technologies & Systems Corp.

635-C North Berry St., Brea, CA 92621

(714) 990-1880 FAX: 714 990-2503 TLX 6502824734 MCI

Inquiry 584.

NATURAL LANGUAGE SOFTWARE

Use JAKE to create a front end to your database, game, or graphics program! JAKE translates English queries and commands into C function calls and data structures. JAKE offers context-sensitive semantic processing; interfaces easily; <64K mem.

\$495. INTERACTIVE DEMO \$10

ENGLISH KNOWLEDGE SYSTEMS, INC.

5525 Scotts Valley Dr. #22, Scotts Valley, CA 95066

(408) 438-6922

Inquiry 579.

PRINT BAR CODES, BIG TEXT, LOGOS

On EPSON, IBM, OKI dot matrix or LaserJet. Design any format/size on ONE easy screen. 1-120 fields/label. 13 text sizes to 1" — readable at 50 ft. AIAG, MIL-STD, 2 of 5, 128, UPC/EAN, Code 39. File Input, FAST—\$279. Logos, Product Symbols. Other menu-driven bar code programs from \$49. 30 day \$ back.

Worthington Data Solutions

417-A Ingalls St., Santa Cruz, CA 95060

(800) 345-4220 In CA: (408) 458-9938

NanoLISP \$99.99

An MS-DOS Common LISP interpreter that supports most Common LISP operations and strictly adheres to the standard. Numerous advanced and extra features, excellent debugging facilities, sample AI programs, fully-indexed manual, free technical support.

Microcomputer Systems Consultants

P.O. Box 6646, Santa Barbara, CA 93160

(805) 967-2270

BAR CODE READERS

From the manufacturer for PC/XT/AT, & PS/2. Attaches as 2nd keyboard, reads as keyed data. External or bus install. With steel wand—\$399. Supports All Novell! Kimtron, Link, Wyse, RS-232. Supports Alloy PC-TERM. Portables, Lasers, Badge. 30 day \$ back.

Worthington Data Solutions

417-A Ingalls St., Santa Cruz, CA 95060

(800) 345-4220 In CA: (408) 458-9938

BAR CODE MADE EASY

PERCON® E-Z-READER™ keyboard interfaces and multiuser RS-232 models make it easy to add bar code to virtually any computer/terminal WITHOUT SOFTWARE MODIFICATION. Immediate shipping. Two year warranty. Bar code printing software available. Call for details on fast, accurate, easy data entry. Substantial reseller discounts.

PERCON®

2190 W. 11th St., Eugene, OR 97402

(503) 344-1189

Inquiry 584.

PC BAR CODE SPECIALISTS

Bar code readers designed for fast, reliable, cost effective data entry. Looks just like keyboard data! Choose from stainless steel wand or laser interface. Also, powerful Bar Code and Text printing software. Great warranty. Dealer inquiries welcome.

Seagull Scientific Systems

15127 N.E. 24th, Suite 333, Redmond, WA 98052

206-451-8966

THE BUYER'S MART

BAR CODE

DATA INPUT DEVICES

Bar Code & Magnetic Stripe Readers for microcomputers & terminals, including IBM PS/2 & others, DEC, Macintosh, AT&T, CT, Wyse, Wang. All readers connect on the keyboard cable & are transparent to all software. Low cost bar code print programs, magnetic encoders, & portable readers are also available. GSA contract #GS00K87AGS5346.

TPS Electronics

4047 Transport, Palo Alto, CA 94303
415-856-6833 Telex 371-9097 TPS PLA
FAX: 415-856-3843

Inquiry 585.

CAD/CAM

PHOTO PLOTTING

from your Smartwork Edit file or any RS-274 Gerber Photo Plot file. Raster type Photoplotting supplied on .007" thick Kodak Ultraline film. Plot data accepted by modem, 5 1/4", 3 1/2" MS-DOS format disks or 9 track mag tape. Gerber plot file 8"x10" plots start from \$15.00. Call for details.

KEPRO CIRCUIT SYSTEMS

Fenton, MO
1-800-325-3878 / 1-314-343-1630 in MO.

Inquiry 586.

P-C-B ARTWORK MADE EASY!

Create and Revise Printed-Circuit-Artwork on your IBM or Compatible

- * Help Screens * Dip & Sip Library
 - * Printer and Plotter Artwork * Supports Mice
 - * Auto-Router available * ICON Menus
- Requirements: IBM or Compatible PC, 384K RAM, DOS 3.0 or later. PCBoards: \$99.00 DEMO: \$10.00

PCBoards

2110 14th Ave. South, Birmingham, AL 35205
(205) 933-1122

Inquiry 587.

P-CAD MOUSE

A quality mouse designed to run with the P-CAD software. It requires one RS232C COM Port for the connection. No external security device is needed any more. Complete hardware and documentation for \$575. Call or write for more information. Three years warranty. Checks, COD, VISA, MC accepted.

UNITEK SYSTEM

9228 Vancouver Drive, Sacramento, CA 95826
(916) 962-6075

P-CAD trademark of Personal CAD System, Inc.

Inquiry 588.

CASE

FINITE STATE PROGRAM COMPILERS

State programs develop quicker, run faster and use less memory than sequential programs. A few keystrokes can replace hundreds of instructions. The Compiler, a CASE software development tool, forms source state programs in: Ada, BASIC, C, FORTRAN and Pascal. FOR IBM DOS. Price \$200 per lang. (With Primer and Debugger) Sampler \$50.00 (With all manuals & credit)

AYECO 5025 Nassau Circle, Orlando
INCORPORATED FL 32808 (407) 295-0930

Inquiry 589.

JOINT APPLICATION DESIGN and PROTOTYPING WORKBENCH

Developers! Reduce your costs and improve user satisfaction. Give users a hands on feel for the system. Build a full working model of a system *in just hours*. PC-PROTO is easy to use, flexible, and writes the documentation for you. From \$149.

Kartech, Inc. (416) 656-2032
165 Pinewood Ave., Toronto, Ontario, Canada M6C 2V6

Inquiry 590.

CD-ROM

CD-ROM Drives & Titles

Largest selection for PC & Mac.
Microsoft Programmers Library & Drive \$995
Computer Library \$695 + Public Domain S/W \$99.

Drives from \$699. Hundreds of titles from \$29.
MC/VISA/AMEX, Money-back Guarantee.
Call or write for free 100 page catalog.

Get it all from "The Bureau"

Bureau of Electronic Publishing
121 Norwood Ave., Upper Montclair, NJ 07043
(201) 746-3031

Inquiry 591.

Government Databases on CD-ROMs

Detailed US databases available on 5 CD-ROMs: Economics, Labor, Agriculture, Consumers, and Food. Soon: Health, Business, Tax, Energy and more. Includes software to make tables, DIF or ASCII. \$65 each, MS-DOS req. CD-ROM publishing services available.

Hopkins Technology

421 Hazel Lane, Hopkins, MN 55343
(612) 931-9376 CIS 74017,614

Inquiry 592.

COMMUNICATIONS

Bi-Directional File X-fers

Multi-Com telecommunications program offers the following

- * Simultaneous Downloading/Uploading
 - * Send/Receive Console Messages During File Transfers
 - * 100% Line Utilization During Multi-File Transfers
 - * Uses Full Duplex ADLC Protocol
 - * More Efficient Than Xmodem, Kermit, etc.
 - * Saves Time and Cuts Connect Costs
- Call for your free diskette information.

Program Pkg., 3 1/2" & 5 1/4" disks, manual . . . \$49.95 + \$4 s/h
Multiplex Systems (800) 222-1064
P.O. Box 16174, Pittsburgh, PA 15242

Inquiry 593.

PC-COMM: A SERIAL DATA COMMUNICATIONS ANALYZER

Displays bidirectional RS-232 data traffic. Logs data to disk monitoring at 19.2K baud. Indicates errors and RS-232 control signals. Runs on all IBM PC/AT/PS2 compatibles. Transfers binary files at 19.2K baud. PC-COMM \$165 Cable option \$65 S/H \$5

Santa Rosa Software

99 Alden Ave., Rohnert Park, CA 94928

707-664-8440

Inquiry 594.

COMPUTER INSURANCE

INSURES YOUR COMPUTER

SAFEWARE provides full replacement of hardware, media and purchased software. As little as \$39 a year provides comprehensive coverage. Blanket coverage; no list of equipment needed. One call does it all. Call 8 am-10 pm ET. (Sat. 9 to 5)

TOLL FREE 1-800-848-3469

(Local 614-262-0559)

SAFEWARE, The Insurance Agency Inc.

Inquiry 595.

CROSS ASSEMBLERS

Retargetable Assembler

Generates code for ANY processor based on a definitions file. Definitions for many common processors included or user can write custom ones. Full-featured: macros, conditional assembly, segmentation, relocatable code, linker, extensive manual. For MSDOS 2.0 or greater. \$195.

AnyWare Engineering

920 Eighth St., Boulder, CO 80302
(303) 442-0556

Inquiry 596.

CROSS ASSEMBLERS

CROSS ASSEMBLERS

Universal Linker, Librarian
Targets for 36 Microprocessors
Hosts: PC/MS DOS, micro VAX, VAX 8000
Developed and supported at:

ENERTEC, INC.

BOX 1312, Lansdale, PA 19446
215-362-0966 MC/VISA

Inquiry 597.

Professional Series

PseudoCode releases its PseudoSam professional Series of cross assemblers. Most popular processors. Macros, Conditional Assembly, and Include Files. Virtually unlimited size. For IBM PC's, MS-DOS 2.0 or greater. With manual for \$500. (MI res. 4% tax). Shipping \$5, Canada \$10, Foreign \$15. Visa/MC. (Dealer Inquiries Welcome).

KORE Inc.

6910 Patterson, Caledonia, MI 49316 616-791-9333
30 Day satisfaction guaranteed or purchase price refunded.

Inquiry 598.

FANTASTIC SIMULATORS

For the 8048, 8051, 8080, 8085, & Z80 families. Full function simulation including ALL MODES of interrupts. Built-in disassembler. Better than expensive I.C.E.'s.

CROSS ASSEMBLERS

We support the 8048, 8051, 8080/8085, 8096 & Z80 families. Just \$75 each.

Lear Com Company

2440 Kipling St./Ste. 206, Lakewood, CO 80215
303-232-2226

Inquiry 599.

CROSS ASSEMBLERS

Macros, PC Compatible, Relocatable, Conditionals, Fast, Reliable from \$150
also: Disassemblers

EPROM Programmer Board

MICROCOMPUTER TOOLS CO.

Phone (800) 443-0779

In CA (415) 825-4200

912 Hastings Dr., Concord, CA 94518

Inquiry 600.

SOFT-X-PLORE

See "BYTE's May '88 issue pg. 78". Disassemble 500 kb (*) program at 10,000/min. (*) in any file, ROM/RAM memory up to 80386 instruction set (*). **SOFT-X-plore:**

- * is for MS/DOS 2.0+ systems
 - * uses 20 algorithms and seven passes (*)
 - * only \$129.95 plus S&H w/30 day guarantee.
- To order call (800) 446-4656 or info (203) 560-0236

Or write: **RJSWANTEK INC.**

178 Brookside Rd., Newington CT 06111

* best on the market MC/VISA accepted

Inquiry 601.

680X0 Cross Assemblers

Now, inexpensive quality 680X0 Cross-Assemblers that use your IBM PC or compatible. All versions support up to 32 char labels, INCLUDE files, PATH names, extensive list output, sorted symbol tables, many common directives, printed manuals. Basic versions create S-records. Linking versions include a librarian & linker, create either S-records or relocatable modules linked to create S-records or binary files. Minimum requirements are 320K, DOS 2.0X, & 1-1/4" DSDD.

Basic 68000/68010—\$49.95 Basic 68020—\$69.95
Linking 68000/68010—\$89.95 Linking 68020/68881—\$129.95
Linking 68030/68881—\$149.95

Checks, VISA, MC accepted. MN residents +6% sales tax. No PO's or COD's please.

RAVEN Computer Systems

Box 12116, St. Paul, MN 55112 (612) 636-0365

Inquiry 602.

THE BUYER'S MART

CROSS ASSEMBLERS

ASSEMBLERS & TRANSLATORS

Over 20 high quality, full function, fast relocatable and absolute macro assemblers are available immediately. Source language translators help you change microcomputers. Hosts: MS/DOS, CPM80, ISIS.

RELMS™

P.O. Box 6719, San Jose, CA 95150

(408) 356-1210

MC/VISA TWX 910-379-0014 AMEX

Inquiry 603.

6800-Family Development Software

Combine our software and your PC for a powerful development system for the Motorola 6800, 6801, 6809, and 68HC11. Our C Compilers feature a complete implementation (excluding bit fields) of the language as described by K&R and yield 30-70% shorter code than other compilers. Our Motorola-compatible Assemblers feature macros and conditional assembly. Linker and Terminal Emulator included.

Wintek Corporation

1801 South St., Lafayette, IN 47904

(800) 742-6809 or (317) 742-8428

Inquiry 604.

Z80/HD64180

Cross assemblers run on PC and are compatible with Microsoft M80/L80. \$195.00 for assembler and linker. We have CP/M emulator cards for PC. Up to 12.5 mhz Z80 clock speed, starting at \$249.95! Also Z80/HD64180 C compilers.

Z-World

1772 Picasso Ave., Davis, CA 95616 (916) 753-3722
See our ad on page 338

Inquiry 605.

DATA CONVERSION

MEDIA CONVERSION/DATA TRANSLATION

More than just a straight dump or ASCII transfer!
Word Processing, DBMS, and Spreadsheet data on Disks or Tapes transferred directly into applications running on Mainframes, Minis, Micros, Dedicated Word Processors, Typesetters, and Electronic Publishing systems.
IBM PS/2 & Macintosh supported
#1 in the translation industry!

CompuData Translators, Inc.

3325 Wilshire Blvd., Suite 1202, Los Angeles, CA 90010

(213) 387-4477 1-800-825-8251

Inquiry 606.

CONVERT

W-2's AND 1099's
TO MAGNETIC MEDIA
FOR IRS
FROM 75¢ PER RECORD
APPROVED SERVICE BUREAU
* * *

DataCopy Service of Texas

3306 W. Walnut #400, Garland, Texas 75042

(214) 272-7751

Inquiry 607.

DATABASE MGMT SYSTEMS

FREE TRIAL dBASE III CLON!!

"1 on 1 is a programmable relational DBMS... The menu mode is a fancier and more complete version of DBases's assistant mode... 1 on 1 = 3!! is a great deal for those who would be glad to have a dBASE III PLUS clone!"

** PC MAGAZINE 5/17/88 **

Free 30 day trial full program USA only or Buy now get free upgrade. Money back guarantee \$69 + \$5. S/H chk/Amex. CAN +\$4. Other +\$10. Call or write:

1 on 1 Computer Solutions

26 Finchwood Dr., Trumbull, CT 06611 203-375-0914
dBASE III is a trademark of Ashton-TATE

Inquiry 608.

DATABASE MGMT SYSTEMS

SOFTWARE KIT PACKAGING

OEM supplier to one of the world's largest computer companies offers quality packaging for your computer products. Quality products reflecting your companies image is our highest priority. Ask about PREFORMATTED DISKETTES for R&D. Call or write.

UNISPEC CORPORATION

4845 Transit Road Unit K-8, Depew, NY 14043

(716) 633-2810 Fax (716) 633-2813

Inquiry 609.

DATA/DISK CONVERSION

QUALITY CONVERSIONS

- Disk • Scanning • Tape

*TYPEWRITTEN \$33 per page to ASCII

*TYPESET 6-24 point Low Rates

(*WP Formats available)

IMAGES

Logos/Line Art/Glossies

1st Run Computer Services Inc.

1261 Broadway, Suite 508, New York, NY 10001

(212) 779-0800

Inquiry 610.

Get the Expertise You Need!

Disk/Disk • Tape/Disk • OCR

Over 1,000 formats! 3 1/2, 5 1/4, or 8 inch disks; 9 track mag tape; 10 MB Bernoulli cartridge. Data base and word processor translation. Specialists in Government Security Data. Call for free consultation.

Computer Conversions, Inc.

9580 Black Mtn. Rd., Ste J, San Diego, CA 92126

(619) 693-1697

Inquiry 611.

DISK CONVERSIONS

Media transfer to or from: IBM, Xerox, DEC, Wang, Lanier, CPT, Microm, NBI, CT, also WP, WS, MS/WRD, DW4, MM, Samna, DEC DX, MAS 11, Xerox-Writer, ASCII.

FREE TEST CONVERSION CONVERSION SPECIALISTS

531 Main St., Ste. 835, El Segundo, CA 90245

(213) 545-6551 (213) 322-6319

Inquiry 612.

DISK & TAPE CONVERSIONS AUTOMATICALLY

SAVE TIME AND MONEY

Over 1000 formats from Mini, Micro Mainframe, Word Processors, & Typesetters.

TAPE Conversions as low as \$2300 MB

DISK Conversions as low as \$1500 per Disk

Call or write TODAY for a cost saving quotation.

CREATIVE DATA SERVICES

1210 W. Latimer Ave., Campbell, CA 95008

(408) 866-6080

Inquiry 613.

DISK INTERCHANGE SERVICE COMPANY

DISC specializes in transferring files between incompatible disk formats, and between disk and 9-track tape.

- Dedicated Word Processors
- Mini, Micro & Mainframe Computers
- 9-Track Tape (800, 1600 and 6250 BPI)
- MSDOS, CP/M, UNIX, DOS, PRODOS, TSX+, RT-11

2 Park Drive • Westford, MA 01886

(508) 692-0050

Inquiry 614.

DATA/DISK CONVERSION

THE #1 CHOICE

in disk & tape conversion

for many leading corporations, government agencies, law firms, and companies in every industry—world-wide.

Free test • Satisfaction guaranteed

Call the helpful conversion experts...

Graphics Unlimited Inc.

3000 Second St. North, Minneapolis, MN 55411

(612) 588-7571

Inquiry 615.

MAG TAPE ↔ Disk Disk ↔ Disk

- We are PC & MAC experts
- Lowest prices guaranteed
- All PC's, MAC's, micros, minis & mainframes supported.

Integrated Data Service

5439 Seneca Place, Simi Valley, CA 93063

(805) 584-0023

Inquiry 616.

IBM PC ↔ to ↔ HP

FILE COPY

IBM PC to HP File Copy allows IBM PCs, PS/2, compatibles to read, write files written by Hewlett Packard Series 70, 80, 200, 300, 1000, 9000's. We offer custom work using our file copy utilities and program translators. Call for estimate, catalog, data sheet.

Oswego Software 312/554-3567

507 North Adams St. Fax 312/554-3573

Oswego, Illinois 60543 Telex 858-757

Inquiry 617.

CONVERSION SERVICES

Convert any 9 track magnetic tape to or from over 1000 formats including 3 1/2", 5 1/4", 8" disk formats & word processors. Disk to disk conversions also available. Call for more info. Introducing OCR Scanning Services.

Pivar Computing Services, Inc.

165 Arlington Hgts. Rd., Dept. #B

Buffalo Grove, IL 60089 (312) 459-6010

Inquiry 618.

DEMOS/TUTORIALS

LEARN THE ABC'S OF 1-2-3

LEADING EDGE'S New Softvision VCR Training ACCELERATES learning LOTUS 1-2-3. You get: 84-min videotape, workbook and practice disk. Now you're up-to-speed on Lotus 1-2-3. Just \$2995 + 2.50 P&H. ORDER NOW. Money back if not delighted. All major credit cards. CALL NOW.

LIFE DYNAMICS

6050 Peachtree Pkwy., #240-226, Norcross, GA 30091

(800) 548-9608 M-F 10-6

(800) 548-5782 Ext. 12 ANYTIME

Inquiry 619.

INSTANT REPLAY III

Build Demos, Tutorials, Prototypes, Presentations, Music, Timed Keyboard Macros, and Menu Systems. Includes Screen Maker, Keystroke/Time Editor, Program Memorizer, and Animator. Rec'd Great Reviews! Simply the BEST. Not copy protected. No royalties. 60 day satisfaction money back guar. IBM and Compatib. \$14995 U.S. Chk/Cr. Cdr. Demo Diskette \$5.00

NOSTRADAMUS, INC.

3191 South Valley Street (ste 252)

Salt Lake City, Utah 84109 (801) 487-9662

Inquiry 620.

THE BUYER'S MART

DISK COMPATIBILITY

IBM PC's USE Mac DISKS

MatchMaker lets you plug any Macintosh external floppy drive into an IBM PC. Half size card and software lets you copy to/from, view directory, initialize, or delete files on the Mac diskette. Works with PCs, XTs, ATs, and compatibles. *The easy way to move information!*

\$149.00 Visa/MC/COD/Chk.

Micro Solutions Computer Products

132 W. Lincoln Hwy., DeKalb, IL 60115 815/756-3411

Inquiry 621.

DISK DRIVES

PS/2 DRIVES FOR PC's AT's

CompatiKit/PC \$279
CompatiKit/AT \$219

Built-in floppy controllers—no problem. Supports multiple drives and formats. Lets your computer use IBM PS/2 1.4M diskettes *plus more!* Call for further information or to place an order. *VISA/MC/COD/CHECK.*

Micro Solutions Computer Products

132 W. Lincoln Hwy., DeKalb, IL 60115 815/756-3411

Inquiry 622.

DISK DUPE EQUIPMENT

DO YOUR OWN DUPLICATION

Copy 10,000 or only 10 in as little as 15 seconds each with famous Mountain Duplication equipment at the very best prices!! See us for all of your duplication equipment needs from Disks to Drives to Duplicators.

SYSTEMS SUPPORT DATA

223 North Royal Avenue, Front Royal, VA 22630
1-800-231-4355

Inquiry 623.

DISK DUPLICATION

WE COPY YOUR DISKS FOR LESS

- Specializing in duplicating disks provided by the customer
- 3 1/2" or 5 1/4"
- 5 1/4" PRICES — 22 cents to 30 cents a disk!!!
- 3 1/2" PRICES — 35 cents to 50 cents a disk!!!
- Bad disks returned
- Fast turnaround
- You choose the quality of the disk, we'll duplicate them!!
- We can help with labels, sleeves, printing — just ask!
- No hidden costs

DISK-O-DATA

366 Massachusetts Ave., Suite 303, Arlington, MA 02174
800-848-8408 617-646-6703

Inquiry 624.

SOFTWARE PRODUCTION

- Disk duplication
- All formats
- EVERLOCK copy protection
- Label/sleeve printing
- Full packaging services
- Warehousing
- Drop shipping
- Fulfillment
- 48-hour delivery
- Consultation & guidance

Star-Byte, Inc.

2880 Bergey Rd., Hatfield, PA 19440
215-997-2470 800-243-1515

Inquiry 625.

DUPLICATION IS THE SINCEREST FORM OF FLATTERY

Let us Flatter you!!! See us for all disk duplication needs. 10 disks to 100,000 and more All formats—All systems. Best prices—Our own in-house printing of documentation—labels-sleeves.

SYSTEMS SUPPORT DATA

223 North Royal Avenue, Front Royal, VA 22630
1-800-231-4355

Inquiry 626.

DISKETTES

CHEAP DISKS!!!

Although this headline may not convey quality our 3 1/2" floppy disks do!

100% Certified

720k only 98¢

1.44 MEG only \$2.60

SYSTEMS SUPPORT DATA

223 North Royal Avenue, Front Royal, VA 22630
1-800-231-4355

Inquiry 627.

DUPLICATION SERVICES

SOFTWARE DUPLICATION

- One Stop Shopping
- Technical Support
- Custom Packaging
- Drop Shipping
- Copy Protection
- Fast Turnaround
- Competitive Pricing

SATISFACTION GUARANTEED

800-222-0490 NJ 201-462-7628

MEGAsoft

P.O. Box 710, Freshold, NJ 07728 See our ads on page 330.

Inquiry 628.

ELECTRONIC PROJECTS

BUILD TALKING ROBOT!

- Build B.E.R.T.® the Basic Educational Robot Trainer
- Featured in BYTE April & May 1987
- Even a child can program this talking Robot, built from off-the-shelf components
- Minimum Kit \$50.00 U.S.
- Complete Kit \$180.00 U.S.
- +10% S/H VISA welcomed
- For further information write to:

GoCo Dist.

Suite 806, 1146 Harwood St., Vancouver, B.C. Canada V6E 3V1
VISA orders only: 604-681-0595

Inquiry 629.

ENTERTAINMENT

★ ★ ★ EGA Chess ★ ★ ★

- "Challenging" . . . "Relentless" . . . —PC Mag
- Fully Animated High Resolution Graphics
- Solves Mate In 7 . . . On Screen Clock
- Huge Opening Book . . . Select Level
- Save/Restart/Print Your Own Games
- Requires 256K EGA/VGA 5.25" disk
- \$34.95 (\$5.00 for Demo)

CUBE Microsystems

P.O. Box 26064, Overland Park, KS 66225
(913) 649-6747 VISA/MC

Inquiry 630.

NEMESIS™ Go Master®

Go, a game of strategic elegance, has been a way of life in the Orient for over four thousand years. Many consider Go to be the secret of the Japanese businessman's success. "While chess is a game of war, Go is a game of market share" (President of Nikko Hotels).

"If you are interested in Go, buy this program."
Game of the Month J. Pournelle BYTE 7/87

Toyogo, Inc. The Leader in Computer Go.
76 Bedford St. #34-Y, Lexington, MA 02173, (617) 861-0488

Inquiry 631.

Sho 'nuff good software

Cast yo eyes 'pun a little ole piece o assembly code, 'n yo be seein how powerful easy it be ta tie yo mind in knots. Sos wise ole Uncle Remus hisself has commented a pile o IBM code jus fo yo ta see. Ta git yourin, be a scribblin GAMES on a scrap o paper. Den be a mailin da simples' purchase order in da whole wide world 'n a check to three smackers ta

ZIPFAST

Box 12236 Lexington, KY 40581-2236
An entry buck shrinkins da disk ta 3.5 inches.
A fancified printed book be 18 o dem der dollars.
Don' furtug yo ever lovin return address.

Inquiry 632.

EPROM PRGMR UTILITIES

GTEK/B&C/SCC PROGRAMMER UTIL

Get this XT/AT menu-driven utility that offers advanced features far beyond what came with your programmer. Fast, powerful, complete, and easy to use. Editor incl. CHKSUM, Search/Replace, etc. File Conversions incl. Intel/Mot/Tek. Handles 16/32 bit merges/splits/transfers with ease. Essential for pgmrs., engrs. techs., etc. Demo \$5. Order now at intro price of \$79 and save \$70!

Ping Software, Inc.

P.O. Box 27468, Golden Valley, MN 55427
CALL (612) 546-3444

Inquiry 633.

FLOW CHARTS

FLOW CHARTING II+ HELPS YOU!

Precise flowcharting is fast and simple with Flow Charting II+. Draw, edit and print perfect charts: bold and normal fonts, 26 shapes — 95 sizes; fast entry of arrows, bypasses & connectors. Fast Insert Line; shrink screen displays 200-column chart; 40 column edit screen for detail work, much more!

PATTON & PATTON

81 Great Oaks Blvd. San Jose, CA 95119
1-800-525-0082 Ext. 42 (Outside CA)
408-629-5376 Ext. 42 (CA/Int'l)

Inquiry 634.

RFFLOW ONLY \$79

RFFlow is a drawing tool designed specifically for flowcharts. Easy to learn, easy to use. 75 shapes automatically adjust in size. Move, copy, or delete groups of objects. 7 levels of zoom. Use mouse or keyboard. On-line user's manual. Supports Windows printers, plotters, and fonts. \$5 trial disc. RFFlow requires Microsoft® Windows.

RFF ELECTRONICS

1053 Banyan Court, Loveland, CO 80538
(303) 663-5767

Inquiry 635.

STRUCTURED FLOW CHART

NSChart creates Nassi-Shneiderman (structured) flowcharts from a simple PDL. Keywords define structures & text strings appear in the chart. Easy to create, even easier to revise! Automatic chart sizing, text centering. Translators from many languages available. For Mac and IBM PC.

SILTRONIX, INC.

P.O. Box 82544, San Diego, CA 92138
1-800-637-4888

Inquiry 636.

HARDWARE

CHIP CHECKER

- 74/54 TTL + CMOS
- 8000 Nat. + Signetics
- 14/4000 CMOS
- 9000 TTL
- 14-24 Pin Chips
- 3" + 6" IC widths

Tests/Identifies over 650 digital chips with ANY type of output in seconds. Also tests popular RAM chips. IBM compatible version \$259. C128 + C64 version \$159.

DUNE SYSTEMS

2603 Willa Dr., St. Joseph, MI 49085
(616) 983-2352

Inquiry 637.

Rack-Mounted AT 286 or 386

Industrial, Med-Tech, Laboratory and Comm. needs
◊ Intel 80286 or 80386 CPU daughter card ◊ Passive back plane (8-10 expansion slots) ◊ Fits standard 19" rack ◊ Heavy-duty dual fans ◊ Clean air filter ◊ High-speed, high-quality hard disk available ◊ Slide-mounted CPU chassis for easy maintenance access ◊ Power supply up to 360 Watts. For details and prices, contact:

(516) 589-8666

International Telecommunications Services

Inquiry 638.

THE BUYER'S MART

HARDWARE

LATEST AWARD BIOS

PC/XT * 286 * 386
Support For:
• Enhanced Keyboards
• EGA & VGA Graphics
• 3.5" Floppies & More...
Authorized AWARD Distributor
Call 1-800-423-3400

KOMPUTERWERK, INC.
851 Parkview Blvd., Pittsburgh, PA 15215

Inquiry 639.

Apple • Service Parts
• Accessories • Systems •
BUY * SELL * TRADE

PRE-OWNED Electronics, Inc.

30 Clematis Avenue, Waltham, MA 02154
800-274-5343 FAX 617-891-3556
Service Centers and Dealers welcome

Inquiry 640.

HARDWARE/ADD-ONS

The World's First Highest Density Module!

* 18 Meg on the smallest surface
* Organization: 2x1024Kx9 bit
* Package: DIL 64 pin Jedec-Standard
* Technology: CMOS, hybrid, 18xHMS1100JP-10
* Compatibility: With two Hitachi HB56A 19-10
* Suitable for extension of basic memory
For more information please write:

TermoTrol Corp.

1888 Century Park East, L.A. CA 90067
Tel. 213 284-3242

Inquiry 641.

HARDWARE/COPROCESSOR

DIGITAL SIGNAL PROCESSOR

DSP products for the IBM PC/XT/AT based on the TMS32010 and TMS320C25. Designed for applications in communications, instrumentation, speech, and numeric processing. Offered with 12 bit 110 KHz A/D and D/A and continuous to disk data acquisition & playback option. \$650 and up.

DALANCO SPRY

89 Westland Ave., Rochester, NY 14618
(716) 473-3610

Inquiry 642.

SC/FOX™ PARALLEL COPROCESSOR

PC/XT/AT/386 plug-in board with Forth software. 10 MIPS operation, up to 50 MIPS burst. 64K to 1M byte memory. Uses Harris RTX 2000™ RISC realtime CPU with 1-cycle multiply, 1-cycle 16-priority interrupts, two 256-word stacks, three 16-bit timer/counters, 16-bit i/o bus. Ideal for real-time control, signal and image processing and multiple board operation. From \$1,995.

SILICON COMPOSERS, INC. (415) 322-8763
210 California Ave., Suite K, Palo Alto, CA 94306

Inquiry 643.

INVENTORY MANAGEMENT

STOCK-MASTER 4.0

Commercial grade inventory management software at micro prices.

- Supports all 12 transaction types
- Trend Analysis
- Quality Control
- Multiple Locations
- Purchase Order Tracking
- Open Order Reporting
- Serial/Lot # Tracking
- Stock Status Reporting
- Activity History Analysis
- Bill of Materials
- Purchase Order Writing
- Order Entry
- Material Requirements
- On Line Inquiry

Applied Micro Business Systems, Inc.

177F Riverside Ave., Newport Beach, CA 92663 714-759-0582

Inquiry 644.

LAPTOP COMPUTERS

LAPTOP SPECIALS

Toshiba • Zenith • NEC • SHARP LAPTOPS • Hard drives for Tandy 1400 LT & Toshiba 1100+ • AFFORDABLE 5¼" or 3½" DRIVE UNITS for LAPTOPS & DESKTOPS • DICONIX PRINTERS • 768 card for T1000 • 2400 BAUD MODEMS for Laptops • Fast reliable and friendly service. For Low Pricing call

COMPUTER OPTIONS UNLIMITED
201-469-7678 (7 Days, 9 am–10 pm Eastern time)

Inquiry 645.

2 PC — FILE TRANSFER UTILITY

2 PC: Connects any two PC's for file transfer and communication. Features * 115,200 baud transfer rate * directory trees * chat mode * file tagging/viewing/deletion * print facility * universal cable * free cable wiring diagram (so you can "roll your own" cable) * 3½" & 5¼" disks. **Complete - \$55 (List: \$80), w/o cable - \$45.** 2PC Lite: Less Expensive, Works Great! **Complete - \$40 (List: \$50), w/o cable - \$30.** RJ-11 cables optional. Both programs have 43-line mode.

Cables sold separately: ser/par, kbd, mon, & others

Thompson Computing, 587F N. Ventu Park Road, Suite 306, Newbury Park, CA 91320, (805) 498-7653.
VISA/MC add 4%. \$350 S/H.

Inquiry 646.

LAP-LINK

The ultimate solution for linking laptop computer with any IBM compatible desktop PC. 115,200 baud transfer rate—faster than any other product available. No installation necessary, easy to use split screen design. Includes incredible "universal cable" that connects any two computers. Transfer entire disks faster than a DOS copy command! Only \$129.95 including universal cable and both 3½" and 5¼" disks. "Bridge" owners can trade in for only \$89.95 w/o cable.

Traveling Software, Inc.

18702 North Creek Parkway, Bothell WA 98011
1-800-343-8080 (206) 483-8088

Inquiry 647.

MEMORY CHIPS

MEMORY CHIPS

41256-15-12-10	Call	51000 (1 Meg)	Call
4164-15	Call	51258 for Compaq 386	Call
4164-12	Call	8087-3-2	Call
41128 Piggy Back for AT	Call	80287-6-8-10	Call
41464-12 (64Kx4)	Call	80387	Call
414256 (256Kx4)	Call	NEC-V20-8	Call
2764,27128,27256,27512	Call	Mouse	Call

Prices subject to change

ESSKAY 718-353-3353

Inquiry 648.

MONITOR INTERFACE

DRIVE MULTIPLE MONITORS

with one PC using our VOPEX video port expanders. Featuring no loss of resolution or color, presentations are more dramatic. We have a VOPEX for PC, PS/2, MAC II & workstations. Units are available from 2 to 10 output ports.

NETWORK TECHNOLOGIES INC.

800-RGB-TECH or 216-543-1646 MC/VISA/AMEX
19145 Elizabeth St., Aurora, OH 44202

Inquiry 649.

POETRY PROCESSOR

remember: **POETRY PROCESSOR** BYTE 2/88 pp 221-228?

Michael Newman's POETRY PROCESSOR, is now available for IBM PC's & compatibles. Includes text editor, form editor & templates, 25,000-word rhyming dictionary, automated metrical scansion, rhyme check, user "Instant Anthology" network... \$89.95 "Should delight anyone who loves words... Justifies a recommendation..." Peter H. Lewis, N.Y. Times... "downright user-stimulating." Washington Post

Call 201-525-2122 for details on ordering POETRY PACKAGE — also incl. N.E.R.D. a slant/internal rhyme dict. \$59.95 & ORPHEUS A-B-C, a poetry tutorial \$49.95 at special XMAS discount. Or send ck or mto:

Michael Newman

c/o The Paris Review, 541 E. 72nd St., NYC, NY 10021

Inquiry 650.

PROGRAM SUBCONTRACT

In a Time Jam?

Let us do your software work in TPascal or TC or M/S C. Guaranteed fast turn, low price and satisfaction. To your specs or we'll design too!

Automated Software

3239 Mill Run, Raleigh, NC 27612

800-227-7681 or 919-782-9045

Inquiry 651.

PROGRAMMERS TOOLS

TURBO SCREEN MASTER

Produce data entry screens and help windows for Turbo Pascal and Turbo C. Menu-driven, context sensitive help, configurable edit commands, flexible data validity checking, colors, IBM-PC graphics characters. Generates Pascal and C source code. Only \$69.95 plus \$3.00 S&H. WA residents add 7.8%.

BLUE BRIDGE SOFTWARE

7401 W. Canal Drive, Suite 343

Kennewick, WA 99336

(509) 627-6729

Inquiry 652.

TLIB™ 4.1 Version Control

"TLIB" is a great system! — PC Tech Journal 3/88. Full-featured configuration mgmt for software professionals. All versions of your code instantly available. Very compact, only changes are stored. Check-in/out looks, revision merge, branching, more. Mainframe deltas for Pansophic, ADR, IBM, Unisys, MS-DOS. \$99.95, or 5-station LAN \$299.95 + shipping

BURTON SYSTEMS SOFTWARE

P.O. Box 4156, Cary, NC 27519 (919) 856-0475

Inquiry 653.

FORTRAN NAMELIST EMULATOR

NAMLST™ subroutine library provides Fortran programmers with an emulation of NAMLIST and associated read and write routines. Supports Fortran 77 data types, 31 character names, control of output line length, tab stops, paging, plus features not found in compilers with NAMLIST statements. Popular Fortran 77 compilers. Literature available. Price \$150.

Data Ready

4647 T Highway 280 E — Suite 150, Birmingham, AL 35242

(205) 991-6381

Inquiry 654.

DEVELOPMENT TOOLS

Professional Programmers Extender: Standard Mac interface, lists, printing, graphics, tiling. Extender GraphPac: Quality color graphs. Line, bar, semi-log, customizable symbols.

INVENTION Software

(313) 996-8108

Inquiry 655.

TURBO PLUS \$149.95

Programming tools for Turbo Pascal 5.0 Screen Painter,

Code Generator, I/O Fields, Dynamic Menus,

Programming Unit Libraries, Sample Programs,

280 Page Illustrated Manual. 60 Day Satisfaction

Guarantee! Brochures & Demo Diskettes avail.

Highly Favorable Reviews! IBM & Compatibles.

Nostradamus Inc.

3191 South Valley St. (Suite 252) Salt Lake City, UT 84109

(801) 487-9662

Inquiry 656.

Order **BYTE** and **BIX** on disk Today!

Full Text of **BYTE** on Disk

Now you can order disks containing the full, machine-searchable text of articles. You can read and search the text with any word processor. Excellent for reference and research! Disks can be ordered singly or by annual subscription. Full text of **BYTE** is available starting from September 1988.

BYTE Program Listings on Disk

BYTE listings on disk are the right choice if you want to compile or read the complete source code listings of programs. BYTE listings are available from December 1985 to present at the prices stated below.

Best of BIX on Disk

Receive highlights of each month's activities on BIX—**BYTE**'s world-class on-line conferencing system. You can read and search the text with any word processor. Each disk contains the most interesting and informative recent discussions specific to the machine you own. For example, order the IBM disk, and get the highlights from IBM-specific conferences. Disks can be ordered singly or by annual subscription.

BYTE also offers listings in print form. Order bound versions of the complete source code listings of programs excerpted from our articles. Handy for quick reference. Order singly or by annual subscription; with or without accompanying diskette version.

Call toll-free for more information: 800-258-5485.

ORDER FORM: To place your order, fill out the card and mail.

	IN USA		OUTSIDE USA	
	Single Month (1 disk)	Annual Subscription (13 disks)	Single Month (1 disk)	Annual Subscription (13 disks)
5-1/4 Inch: <input type="checkbox"/> IBM PC Other disk formats available. Call toll-free.	<input type="checkbox"/> Full Text of BYTE \$9.95 <input type="checkbox"/> BYTE Listings \$9.95 <input type="checkbox"/> Best of BIX \$9.95	<input type="checkbox"/> Full Text of BYTE \$79.95 <input type="checkbox"/> BYTE Listings \$79.95 <input type="checkbox"/> Best of BIX \$79.95	<input type="checkbox"/> Full Text of BYTE \$12.95 <input type="checkbox"/> BYTE Listings \$12.95 <input type="checkbox"/> Best of BIX \$12.95	<input type="checkbox"/> Full Text of BYTE \$99.95 <input type="checkbox"/> BYTE Listings \$99.95 <input type="checkbox"/> Best of BIX \$99.95
3-1/2 Inch: <input type="checkbox"/> Apple Macintosh <input type="checkbox"/> Atari ST <input type="checkbox"/> Amiga <input type="checkbox"/> IBM PS/2	<input type="checkbox"/> Full Text of BYTE \$10.95 <input type="checkbox"/> BYTE Listings \$10.95 <input type="checkbox"/> Best of BIX \$10.95	<input type="checkbox"/> Full Text of BYTE \$89.95 <input type="checkbox"/> BYTE Listings \$89.95 <input type="checkbox"/> Best of BIX \$89.95	<input type="checkbox"/> Full Text of BYTE \$13.95 <input type="checkbox"/> BYTE Listings \$13.95 <input type="checkbox"/> Best of BIX \$13.95	<input type="checkbox"/> Full Text of BYTE \$109.95 <input type="checkbox"/> BYTE Listings \$109.95 <input type="checkbox"/> Best of BIX \$109.95

FOR DIRECT ORDERING
CALL TOLL FREE:
800-258-5485



Call: M-F, 8:30 a.m. to 4:30 p.m. Eastern Time
(603-924-9281 for New Hampshire residents)

For credit card orders only.

BYTE

PLEASE COMPLETE IN FULL

FEBRUARY

Name _____

Address _____

City _____ State _____ Zip _____

County or Parish _____ Country _____

Credit Card # _____ Exp. Date _____

Signature _____ Date _____

Please allow 4-8 weeks for delivery.

• Please indicate the issue date below. If you are beginning an annual subscription, note the starting issue.

Full Text of **BYTE**

Month _____ Year _____

BYTE Program Listings

Month _____ Year _____

Best of BIX

Month _____ Year _____

Check enclosed

MasterCard

VISA

U.S. funds enclosed
(If ordering from outside the U.S. please remit in U.S. funds drawn on U.S. bank. Thank you.)

Order **BYTE** and **BIX** on disk Today!

Full Text of **BYTE** on Disk

Now you can order disks containing the full, machine-searchable text of articles. You can read and search the text with any word-processor. Excellent for reference and research! Disks can be ordered singly or by annual subscription. Full text of **BYTE** is available starting from September 1988.

BYTE Program Listings on Disk

BYTE listings on disk are the right choice if you want to compile or read the complete source code listings of programs. **BYTE** listings are available from December 1985 to present at the prices stated below.

Best of **BIX** on Disk

Receive highlights of each month's activities on **BIX**—**BYTE**'s world-class on-line conferencing system. You can read and search the text with any word processor. Each disk contains the most interesting and informative recent discussions specific to the machine you own. For example, order the **IBM** disk, and get the highlights from **IBM**-specific conferences. Disks can be ordered singly or by annual subscription.

BYTE also offers listings in print form. Order bound versions of the complete source code listings of programs excerpted from our articles. Handy for quick reference. Order singly or by annual subscription; with or without accompanying diskette version.

Call toll-free for more information: 800-258-5485.

ORDER FORM: To place your order, fill out the card and mail.



NO POSTAGE
NECESSARY
IF MAILED
IN THE
UNITED STATES

BUSINESS REPLY MAIL

FIRST CLASS MAIL PERMIT NO. 10 PETERBOROUGH, NH

POSTAGE WILL BE PAID BY ADDRESSEE

BYTE & BIX on Disk

One Phoenix Mill Lane
Peterborough, NH 03458-9990



THE BUYER'S MART

PROGRAMMERS TOOLS

Get INSIDE!

INSIDE! is a powerful software performance analysis tool for popular PC compilers. INSIDE! measures the execution time of every function or procedure with microsecond accuracy or computes how often each source line is executed. Simply compile your application and INSIDE! does the rest. \$75. VISA/MC/COD

Paradigm Systems Inc.

P.O. Box 152, Milford, MA 01757
(800) 537-5043 In MA: (508) 478-0499

Inquiry 657.

Modula-2

EmsStorage is an advanced memory manager for M2. Detects and uses LIM expanded memory if present, or DOS memory if not; manages objects as small as one byte. Only \$89. For JPI TopSpeed, Logitech, Stony Brook, FST compilers. From the creators of Repertoire, Graphix, ModBase, NetMod and the Repertoire/Retrieve Toolkit. MC/VISA/AMEX/PO/COD.

4536 SE 50th, Portland, OR 97206
PMI (503) 777-8844; FAX: (503) 777-0934

Inquiry 658.

FREE BUYER'S GUIDE

Programmer's Connection is an independent dealer representing more than 300 manufacturers with over 800 software products for IBM personal computers and compatibles. We have serviced the professional programmer since 1984 by offering sound advice and low prices. Call or write today to receive your FREE comprehensive Buyer's Guide.

Programmer's Connection US 800-336-1166
7249 Whipple Ave. NW Canada 800-225-1166
North Canton, OH 44720 International 216-494-3781

Inquiry 659.

'C' DOCUMENTATION TOOLS

- C-CALL \$39 Creates graphic-tree of caller/called structures, and files-vs-procedure table-of-contents
- C-HDR \$39 Creates/inserts/updates headers for each procedure showing caller/called and identifiers
- C-LIST \$29 List, action-diagram, reformat programs
- C-REF \$29 Local/global/parameter cross reference
- SPECIAL \$99 All 4 plus integrated C-DOC version

SOFTWARE BLACKSMITHS INC.
6064 St. Ives Way, Mississauga, ONT Canada L5N-4M1
(416) 858-4466

Inquiry 660.

PUBLIC DOMAIN

OUTSTANDING IBM SOFTWARE ONLY \$3.00/DISK or Less

The Best of Shareware and Public Domain Programs. 5.25" and 3.50" formats.

Orders shipped First Class within 24 hours

Satisfaction guaranteed.

Write or call for FREE CATALOG

or Send 75¢ for a disk Catalog and sample programs

A.C.L. (916) 973-1850
1621 Fulton Ave., Suite #35-B2, Sacramento, CA 95825

Inquiry 661.

\$3.00 SOFTWARE FOR IBM PC

Hundreds to choose from, wordprocessors, databases, spreadsheets, games, lotto, communications, business, music, bible, art, education, language and useful utilities for making your computer easier to learn. Most programs have documentation on the disk.

WRITE FOR YOUR FREE CATALOG TODAY!

BEST BITS & BYTES

P.O. Box 8245, Dept-B, Van Nuys, CA 91409

In CA: (818) 764-9503 800-245-BYTE

Inquiry 662.

PUBLIC DOMAIN

75¢ per DISK SALE

20 TOP IBM PC PD/SW DISKS (360K)
ONLY \$15 + \$3 S&H

QubeCalc, EDRAW, AutoMenu, Math Tutor, PC-DOS Help, Baker's Dozen, Languages, EZ-Form, PC-Style, PackDisk, PC-Stock, KidGames, Best Games, Home Inventory, PC-Outline, Form Letters, ImagePrint, SideWriter, PC-Prompt, Best Utilities.

BRIGHT FUTURES INCORPORATED

Dept. BYM, P.O. Box 1030, East Windsor, CT 06088
FREE CATALOG (\$1 per disk/50¢ rental)

Inquiry 663.

FREE SOFTWARE BEST OF PUBLIC DOMAIN & SHAREWARE.

Carefully selected and edited programs for I.B.M. Send S.A.S.E. for free catalog.

C.C.S., Inc. Dept. B1

P.O. Box 312, Lafayette Hill, PA 19444

Inquiry 664.

FREE CATALOG PUBLIC DOMAIN/SHAREWARE

- 400 IBM PC & compatibles disks •
- 200 Amiga disks • 125 Atari ST disks

PC disks as low as \$1.25 each, Amiga & ST as low as \$1.60 each! Rent or buy. Free shipping! Call toll free, write or circle reader service for FREE BIG CATALOG with full descriptions. Please specify computer—48 hr. turnaround!

Computer Solutions

P.O. Box 354—Dept. B, Mason, Michigan 48854
1-800-874-9375 (M-F 10-6 EST) 1-517-628-2943

Inquiry 665.

RENT SOFTWARE \$1/DISK

Rent Public Domain and User Supported Software for \$1 per diskfull or we'll copy. IBM (3 1/2" also), Apple, C-64, Sanyo 550 and Mac. Sampler \$3. VISA/MC. 24 hr. info/order line. (619) 941-3244 or send #10 SASE (specify computer) Money Back Guarantee!

FutureSystems

Box 3040 (T), Vista, CA 92083
office: 10-6 PST Mon-Sat. (619) 941-9761

Inquiry 666.

FREE IBM SOFTWARE

FREE CATALOG also contains SHAREWARE, 5 1/4 and 3 1/2-inch. All categories. ENGINEERING, CAD, DESKTOP PUBLISHING, LANGUAGES, UTILITIES, BUSINESS, GRAPHICS, SPREADSHEETS, WORD PROCESSORS, CHURCH, MEDICAL, HEALTH, EDUCATION, HOME.

SECTOR SYSTEMS COMPANY, INC.

Dept. B-2, 416 Ocean Avenue, Marblehead, MA 01945
(617) 639-2625

Inquiry 667.

FREE SOFTWARE

Buy or Rent \$1/disk

World's largest Free Software Library of IBM PC & Compatibles and Macintosh. Over 3000 programs for Religion, Utilities, Business, Com., Word Processor, Education, and Games on 5.4" and 3.5" format. Best quality, Lowest rate, and Fastest service. For fast free catalogue write to:

SOFTSHOPPE

P.O. Box 709, Ann Arbor, MI 48105
(313) 763-8721

Inquiry 668.

PUBLIC DOMAIN

FREE SOFTWARE

We send you 15-20 new IBM programs a month on 5 disks—FREE! You pay only \$5. shipping/handling. Annual membership reg. \$29.95. Join today for only \$9.95 and we'll send you over 30 programs on 10 disks as a bonus—FREE! No gimmicks—no catches!

toll free 800 669-2669 ext 348

SOFTWARE of the MONTH CLUB
we take visa/mastercard/amex

Inquiry 669.

PD & SHAREWARE

SOFTWARE for IBM PC & CP/M

The Source Library for UK & European Users.

Since 1982 PDSL has been considered the major source library for professional users. As well as all the big name items we hold all those hard to find utilities and source code files not held by other libraries. If you would like access to our 2000 plus disks send two IRCs (UK two 19p stamps) for full catalogue. Author distribution enquiries also welcome.

The Public Domain & Shareware Library

Winscombe House, Beacon Rd., Crowborough
Sussex TN6 1UL, England Tel 0892 663298

Inquiry 669.

SECURITY

THE ULTIMATE COPY PROTECTION

- Completely Menu Driven
- Defeats all Hardware/Software Copiers
- No Source Code Changes
- Multiple Layering
- No Damaged Media
- Full Hard Disk Support
- Unlimited Metering
- FREE Demo Disk

STOPCOPY™ \$325** STOPCOPY PLUS™ \$450**
BBI COMPUTER SYSTEMS®

14105 Heritage La., Silver Spring, MD 20906 (301) 871-1094

Inquiry 670.

PRIVACY-YES/VIRUS-NO

"TOBY" is a complete and powerful software package for the protection of privacy and integrity of all data files such as spreadsheet, data base, word processing, graphics, CAD/CAM files, etc. Special format conversions for modern IBM use included. TOBY employs simple menu-driven commands featuring helpful user dialogue. A clear, concise instruction manual is included for initial orientation. For the IBMPC line and true compatibles; coprocessor (8087, 80287 or 80387) required, program memory 38K. Specify 5.25" or 3.5" media. TOBY features a practical yet serious cryptographic capability based on the professionally-respected algorithm of MacClann and Mansaglia (no DES, no RSA). US sales only. Check or MO for \$125 (Mass orders add 5%).

CSI

P.O. Box 98, Newton, MA 02168

Inquiry 671.

YOU CAN HAVE TOTAL PRIVACY!

Get Dynamic Data Protection Without Risk!
Try It On Our Money Back Guarantee!

Powerful data protection for PC/AT-documents, databases, spreadsheets-any data. DES and Ultra Fast encryption methods for maximum protection. You can use it easily through menu and command line modes. Instant Help. Easy-to-read manual. \$49 gives you your best value in protection! Call Today!

DIARY 1-800-873-4279
P.O. Box 704-43, Bellevue, WA 98007

Send for Additional Details Today!

Inquiry 672.

BIT-LOCK® SECURITY

Piracy SURVIVAL 5 YEARS proves effectiveness of powerful multilayered security. Rapid decryption algorithms. Reliable/small port transparent security device. PARALLEL or SERIAL port. Complemented by economical KEYLOCK™ and multifunctioned COMPUTELOCK™ including countdown, timeout, data encryption, and multiproduct protection.

MICROCOMPUTER APPLICATIONS

3167 E. Otero Circle, Littleton, CO 80122
(303) 922-6410/770-1863

Inquiry 673.

THE BUYER'S MART

SECURITY

COPY PROTECTION

The world's leading software manufacturers depend on Softguard copy protection systems. Your FREE DISKETTE introduces you to SuperLock™—invisible copy protection for IBM-PC (and compatibles) and Macintosh.

- Hard disk support
- No source code changes
- Customized versions
- LAN support
- New upgrades available

SOFTGUARD SYSTEMS, INC.
710 Lakeway, Suite 200, Sunnyvale, CA 94086
FAX (408) 773-1405

Inquiry 674.

SOFTWARE/ACCOUNTING

dBASE BUSINESS TOOLS

- General Ledger
- Accounts Recvbl.
- Order Entry
- Sales Analysis
- Purch Ord/Inventory
- Accounts Payable
- Job Costing
- Job Estimating

\$99 EA. + s&h w/dBASE 2, 3 or 3+ SOURCE CODE

dATAMAR SYSTEMS™ Cr. Crd/Chk/COD
4876-B Santa Monica Ave.
San Diego, CA 92107 **(619) 223-3344**

Inquiry 675.

SOFTWARE/BASIC

QB 4.5 LIBRARIES

Make QuickBASIC 4.5 even better with our **FINALLY!** Family of Products. Programming tools, WINDOWING, Graphics and more!
FREE CATALOG of Compiled BASIC Tools.
(800) 423-3400.

KOMPUTERWERK, INC.
851 Parkview Blvd., Pittsburgh, PA 15215

Inquiry 676.

QuickWindows

As seen in the Microsoft Value-Pack Catalog! Create windows, pop-up and pull-down menus, data-entry screens, and multiple-input dialog boxes quickly and easily. Full support of Microsoft mouse. Join the many Fortune 500 companies using QuickWindows and order your copy today. QuickWindows \$79. Advanced \$139. For Microsoft QuickBASIC or BASCOM. See pg.78, BYTE, March '88.

Software Interphase, Inc.
5 Bradley St., Suite 106 • Providence, RI 02908
(401) 274-5465 Call now for Free Demo Disk

Inquiry 677.

SOFTWARE/BUSINESS

DATA ENTRY SYSTEM

Head-down data entry with two-pass verification for the IBM PS/2-PC/XT/AT & compatibles. Features include: Auto dup/skip, verify bypass, range checks, table lookups, a complete edit language. Fully menu driven. Price \$395

Call for our free 30 day trial period.
COMPUTER XEUS
21929 Makah Rd., Woodway, WA 98020
Tel: 206/776-6443 USA: 800/356-0203 Fax: 206/776-7210

LP88-SPREADSHEET LP

Our best-selling menu-driven linear programming system now solves problems with 1000 constraints and 5000 variables up to 30 times faster. New version reads/writes Lotus worksheets. Use 1-2-3/Symphony as a matrix generator or post processor. Many other features including interactive and batch operation, spreadsheet-style display, equation processor, problem/basis storage, file I/O, Simplex restart, report generator, sensitivity analysis. IENews says: "The flexibility and features of this program are a bargain at its low price." \$149 with 8087 support and 100-page manual. \$29 for working demo and manual.

EASTERN SOFTWARE PRODUCTS, INC.
P.O. Box 15328, Alexandria, VA 22309 (703) 360-7600

Inquiry 678.

SOFTWARE/BUSINESS

dFELLER Inventory

Business inventory programs written in modifiable dBASE source code.

dFELLER Inventory \$150.00
Requires dBASE II or III, PC-DOS/CPM
dFELLER Plus \$200.00
with History and Purchase Orders
Requires dBASE III or dBASE III Plus (For Stockrooms)

Feller Associates
550 CR PPA, Route 3, Ishpeming, MI 49849
(906) 486-6024

Inquiry 679.

Contact POWER

E-Z contact management system for hands-on lawyers, consultants, RE agents, mfr. reps & other client based professionals. Instant data, form letters, labels, schedules, time logs, ticklers—auto phone work—tracks mail, referrals, projects—text editor for notes & letters. Only \$395. IBM, 384K, HD. Send \$5.00 for working demo.

Parkside Computer Systems (714) 838-1888
1241 Landfair, Santa Ana, CA 92705 Visa/MC

Inquiry 680.

Simplify the Business of Business with
SIMPLESOFT's Business Software

- General Ledger
- Accts Payable
- Accts Receivable
- Cashflow

\$49.95 each + S&H
*** Write for FREE CATALOG ***

SIMPLESOFT SOFTWARE CORPORATION
1402 E. Guadalupe Road, Suite 228, Tempe, AZ 85283
(602) 831-8105

Inquiry 681.

SOFTWARE/ENGINEERING

PRACTICAL ENGINEERING TOOLS

Hobbyists—Students—Engineers

CIRCUIT DESIGN_CompDes, menu selections from basic electricity through circuit designs.
MATHEMATICS_CompMath, menu selections from general math through statistics.
ANALYSIS_CompView, Fourier Analysis of waveforms and filters. PC/MSDOS. \$49 each. VISA/MC

BSOFT SOFTWARE (614) 491-0832
444 Colton Rd., Columbus, OH 43207

Inquiry 682.

Affordable Engineering Software

FREE APPLICATION GUIDE & CATALOG

Circuit Analysis • Root Locus • Thermal Analysis • Plotter Drivers • Engineering Graphics • Signal Processing
• Active/Passive Filter Design • Transfer Function/FFT Analysis • Logic Simulation • Microstrip Design • PC/MSDOS • Macintosh • VISA/MC

BV Engineering Professional Software
2023 Chicago Ave., Suite B-13, Riverside, CA 92507
(714) 781-0252

Inquiry 683.

MATHMATE

Versatile Math software with direct connection to Lotus 1-2-3 for advanced curve fitting and automatic LOG-LOG plots. Powerhouse solutions for more day to day math problems. Includes 3 solvers, 3 calculators and math graphics. \$149. 30 day money back guarantee.

MCAE Technologies, Inc.
3474 Nova Scotia Ave., San Jose, CA 95124
(408) 371-6095

Inquiry 684.

SOFTWARE/ENGINEERING

SIMULATION WITH GPSS/PC™

GPSS/PC™ is an IBM personal computer implementation of the popular mainframe simulation language GPSS. Graphics, animation and an extremely interactive environment allow a totally new view of your simulations. Simulate complex real-world systems with the most interactive and visual yet economical simulation software.

MINUTEMAN Software

P.O. Box 1717Y, Stow, Massachusetts, U.S.A.
(508) 897-5662 ext. 540 (800) 223-1430 ext. 540

Inquiry 685.

ENGINEERING SOFTWARE

Public Domain software and shareware for the IBM pc. Only \$5 per disk distribution fee.

- Circuit analysis Disk 1000
- Curve fitting Disk 6102
- Filter design Disk 1500
- Statistics Disk 6300
- Resident Help Disk 5701
- On Side print Disk 4020
- Graph plotting Disk 6202
- and many more

For a FREE CATALOG:
New England Software Library
P.O. Box 696, Shelburne, VT 05482 (802) 985-2928

Inquiry 686.

Circuit Analysis — SPICE

Non-linear DC & Transient; Linear AC.
★ Version 3B1 with BSIM, GaAs, JFET, MOSFET, BJT, diode, etc. models, screen graphics, improved speed and convergence.
★ PC Version 2G6 available at \$95.
Call, write, or check inquiry # for more info.

Northern Valley Software
28327 Rothrock Dr., Rancho Palos Verdes, CA 90274
(213) 541-3677

Inquiry 687.

FREE ENGINEERING MAGAZINE

Personal Engineering is a monthly magazine sent free of charge (USA only) to scientists/engineers who use PCs for technical applications. Topics each month include **Instrumentation • Data Acq/Control • Design Automation**. To receive a free sample issue and qualification form either circle below or send request on letterhead to:

Personal Engineering Communications
Box 1821, Brookline, MA 02146

Inquiry 688.

EC-Ace ANALOG CIRCUIT ANALYSIS

You can afford to get started with **EC-Ace**, a subset of the powerful **ECA-2** circuit simulator. Includes all the basics and built-in graphics.

- AC, DC, Temperature, Transient
- A full 525 pg. ECA-2 manual.
- Interactive, twice as fast as SPICE.

EC-Ace 2.31 IBM PC or Mac \$145.
Call 313-663-8810 for FREE DEMO
Tatum Labs, Inc.
1478 Mark Twain Ct., Ann Arbor, MI 48103

Inquiry 689.

TUTSIM™ FANSIM™

- Time Domain
- Control sys. Simulation
- Linear and nonlinear
- Block Diagram Syntax
- Transient response
- \$40 (eval copy)/\$495
- Frequency Domain
- FFT, Inverse FFT
- Find Xfer Functions
- Find roots, poles
- Bode, Nyquist, tables
- \$40 (eval copy)/\$395 full

Info, examples: **TUTSIM Products**
200 California Ave., #212, Palo Alto, CA 94306
(415) 325-4800

Inquiry 690.

THE BUYER'S MART

SOFTWARE/GEOLOGICAL

GEOLOGICAL CATALOG

Geological software for log plotting, gridding/counting, hydrology, digitizing, 3-D solid modelling, synthetic seismogram, fracture analysis, image processing, scout ticket manager, over 50 programs in catalog. Macintosh tool Please call, or write, for Free Catalog!

RockWare, Inc.

4251 Kipling St., Suite 595, Wheat Ridge, CO 80033 USA
(303) 423-5645

SOFTWARE/INVESTMENT

Compare over 1,300 Mutual Funds with Business Week's Mutual Fund Scoreboard and your IBM PC or compatible. Use simple menu commands to search and sort on over 25 information fields. No additional software required. Data transports easily to Lotus 1-2-3. Search, total, average, rank, display and print reports—at the touch of a key!

Only \$69.95 each for an Equity or Fixed Income Diskette
\$199.95 per subscription for either the Equity or Fixed Income version
\$319.90 for a subscription to both versions (a savings of \$80!)

Order now or receive more information by calling 1-800-553-3575
(In Illinois, call 1-312-250-9292)

Or write to: **Business Week Diskettes**
P.O. Box 621, Elk Grove, IL 60009

Inquiry 696.

SOFTWARE/MATHEMATICS

NOW!! C MEANS BUSINESS

Exact BCD type math in C. Greenleaf Business MathLib lets you use C for financial applications requiring exact decimal math. Built in features include arrays, amortization, depreciation, interest, percentages, statistics, discounted cash flow analysis, bond calculations, internal rate of return, linear estimation, time value of money, and more.

Greenleaf Software, Inc.

(800) 523-9830 (214) 248-2561

Inquiry 702.

SOFTWARE/GRAPHICS

TurboGeometry Library

Over 150 2&3 dimensional routines, includes Intersections, Transformations, Equations, HiddenLines, Perspective, Curves, Areas, Volumes, Clipping, Planes, Vectors, Distance, Polydecomp, IBM PC and Comp. MAC, MSDOS 2+, Turbo Pascal, Turbo C, MSC & Turbo Pascal MAC. 400 pg. manual, source code, \$149.95 + 5.00 S&H. Foreign add \$160.00. VISA, MC, Chk., P.O. 30 Day guarantee.

Disk Software, Inc.

2116 E. Arapaho Rd., #487, Richardson, TX 75081
1-800-635-7760
(214) 423-7288 FAX: 214-423-4465

Inquiry 691.

STOCKS OPTIONS FUTURES

Turn Your PC Into A

MARKET QUOTATION MONITOR

100 page book covers satellite and radio data reception of financial news and quotes for your PC, \$19 (includes demo diskette). Free informative catalog of

- Data receivers and kits
- Quote processing and display software
- Descrambling software utilities

303-223-2120 \$5 Demo Diskette

DATArx
111 E. Drake Rd., Suite 7041, Fort Collins, CO 80525

Inquiry 697.

MATH EDITING FOR THE PC

$$x_i^2 = \sum_{k=0}^{\infty} [x_k^{2n} \binom{n}{k}] + \left(\frac{\int F ds}{\sqrt{\alpha \pm \beta x}} \right)$$

- MathEdit constructs math equations to be inserted into WordPerfect and TeX documents.
- User-friendly interface—no new word processor needs to be learned
- MathEdit—\$149

K-TALK
COMMUNICATIONS

50 McMillen Ave., Suite 100
Columbus, Ohio 43201
(614) 294-3535

Inquiry 703.

SEGS v2.0

Scientific Engineering Graphics System

- Logarithmic, Time/Date & Linear Axes.
- Easy Curve Fitting and Data Smoothing.
- 1-2-3 Interface & Numeric Spreadsheet.
- Supports all Video & Device Standards.
- 10 Curves with up to 8000 points each.

Edmond Software, Inc.

5900 Mosteller Dr. #1124 405-642-0558
Oklahoma City, OK 73112 800-992-3425

Inquiry 692.

Historical Stock Market Data

MOLLY (RE: "What's New" BYTE 10/88 p. 84), with over 150,000 daily prices (4 Mbytes) on major indexes many from the 1920s. Including all 3 DOW Indexes, S&P 500, Int. Rates and more for \$199.95. ECONOMIC Database with 160 data series, most begin in the 1940s, for \$159.95. All files are in WK1 format for use with spreadsheets. IBM & Mac. Demo disk \$50.00. Guaranteed!

MarketBase Inc.

250 W. 90 St., New York, NY 10024
1-800-MARKETS5

Inquiry 698.

MATHEMATICIANS—ENGINEERS

Have you ever seen functions of a complex variable? Would you like to really understand differential operators like div, grad and curl? How about a peek into the fourth dimension? Call or write for information on our latest PC and Macintosh software.

Lascaux Graphics

3220 Steuben Ave., Bronx, NY 10467
(212) 654-7429

Inquiry 704.

SOFTWARE/LANGUAGES

FORTHWITH DRUMA FORTH-83

Powerful. Well designed. User friendly. Attractively priced. Enhance productivity. Reduce development time.

- No 64K limit, 16 bit speed to 320K, 1Mb+ memory.
- On-line doc/glossary, full DOS & file interface.
- Assembler, editor, examples, many utilities.

15 day unconditional guarantee. From \$79, S&H \$2, VISA/MC, IBM PC/XT/AT & all compatibles. Other packages: Inquire

DRUMA INC.

6448 Hwy. 290 East E103, Austin, TX 78723
Orders: 512-323-0403 BBoard: 512-323-2402

Inquiry 699.

SOFTWARE/MORTGAGE

MORTGAGE COMPUTER SYSTEMS

For LENDERS:

- Construction Mortgage Servicing.
- Conventional Mortgage Servicing.
- Reverse Mortgage.

For BROKERS:

- Best fit Borrower/Property/Lender/Commission.
- Risk Management.
- Automatic Documents Creation.

Runs on IBM PC/XT/AT and compatibles.

synthetic intelligence inc.

(212) 967-2399 New York, NY, 10001

Inquiry 705.

PEN PLOTTER EMULATOR

FPLLOT turns your dot matrix or laser printer into an HP pen plotter. Fast hi-res output. No jagged lines. Vary line width, color. Works with Autocad, Drafax, etc. Supports NEC P5/P6, IBM Proprietary, Epson LQ/FX, Toshiba, HP Laserjet. Hercules/CGA/EGA/VGA for preview. \$64 check/m.o.

FPLLOT CORPORATION

24-16 Steinway St., Suite 605, Astoria, NY 11103
212-418-8469

Inquiry 693.

FORTRAN for Macintosh

Language Systems FORTRAN is a full-featured FORTRAN 77 compiler integrated w/MPW. Full ANSI FORTRAN 77 plus VAX-type extensions. SAME numerical calculations & data types incl. COMPLEX*16, 68000, 68020 and 68881 object code. Arrays greater than 32K. Link with Pascal, C, MacApp. \$359 w/MPW via air. MC/VISA/Check. MAC+, SE, Mac II. HD req.

Language Systems Corp.

441 Carlisle Drive, Herndon, VA 22070
(703) 478-0181

Inquiry 700.

SOFTWARE/PACKAGING

HARD TO FIND COMPUTER SUPPLIES FOR SOFTWARE DEVELOPERS & POWER USERS

Cloth binders & slipcases like IBM's. Vinyl binders, boxes, and folders in many sizes. Disk pages, envelopes, & labels. Low quantity imprinting. Bulk disks. Everything you need to bring your software to market. Disk and binder mailers. Much more! Low Prices! Fast service. Call or write for a FREE CATALOG.

Anthropomorphic Systems, Limited

376 E. St. Charles Rd., Lombard, IL 60148
1-800-DEAL-NOW 312-629-5160

Inquiry 706.

GRAPHICS PRINTER SUPPORT

AT LAST! Use the PrtSc key to make quality scaled B&W or color reproductions of your display on any dot matrix, inkjet, or laser printer. GRAFPLUS supports all versions of PC or MS-DOS with IBM (incl. EGA, VGA), Tecmar, and Hercules graphics boards. \$49.95.

Jewell Technologies, Inc.

4740 44th Ave. SW, Seattle, WA 98116
800-628-2828 x 527 (206) 937-1081

Inquiry 694.

FORTRAN PROGRAMMER?

Now you can call 2-D and 3-D graphics routines within your FORTRAN program.

GRAFATIC: screen routines \$135.
PLOTATIC: plotter driver 135.
PRINTATIC: printer driver 135.

For the IBM PC, XT, AT & compatibles. We support a variety of compilers, graphics bds., plotters and printers.

MICROCOMPATIBLES

301 Prelude Dr., Dept. B, Silver Spring, MD 20901 USA
(301) 593-0683

Inquiry 695.

EASY TO C

The C Workshop interactive software teaches you C. Do real C program exercises with built-in editor and compiler. Feedback guides you to solution. All you need to learn C, including our 384-page book. \$69.95 + \$5 Ship. PC compatibles.

MC/VISA/Check.

Wordcraft

3827 Penniman Ave., Oakland, CA 94619
(800) 762-8003 (PST) (415) 534-2212 in CA

Inquiry 701.

SAVE SAVE SAVE SAVE LET'S TALK LABELS

We do disk labels (5 1/4" & 3 1/2")
• Better • Faster • Cheaper •
Because we specialize in disk labels... Let's Talk

We also have Tyvek Sleeves
Mailers • Binders • Vinyl Pages

We are a complete software packaging service.

Hice & Associates

9303 Cincinnati-Columbus Rd., West Chester, OH 45069
513-777-0133

Inquiry 707.

THE BUYER'S MART

SOFTWARE/PRINTER

PRINTER GENIUS

Powerful memory resident printer management • Control printer features from menus or within documents • Print spool to disk files or memory • Background print • File & directory browse • Edit small text • and more... • User friendly pop-up screens • 92 page manual • Preset for all printers • Completely flexible • PC MS-DOS • \$89 + \$4 S/H • VISA/MC

Nor Software Inc.

527 3rd Ave., Suite 150, New York, NY 10016
(212) 213-9118

Inquiry 708.

SOFTWARE/SCANNERS

Optical Character Recognition

Stop retyping: PC-OCR* software will convert typed or printed pages into editable text files for your word processor. Works with HP ScanJet, Panasonic and most other scanners. Supplied with 16 popular fonts. User trainable; you can teach PC-OCR* to read virtually any typestyle incl. foreign fonts. Proportional text, matrix printer output, Xerox copies OK. \$385. Check VISA/MC/AmExp/CD

Essex Publishing Co.

P.O. Box 391, Cedar Grove, NJ 07009
(201) 783-6940

Inquiry 709.

SOFTWARE/SCIENTIFIC

DATA ACQUISITION & ANALYSIS ON PC'S

• Free application assistance. Tell us about your DSP, process control, A/D or D/A needs. Our expert engineering staff will provide you with a system solution to fit your needs and budget.
• A/D & IEEE 488 boards from Metrabyte, Scientific Solutions and National Instruments.
• Analysis software including PRIME FACTOR FFT subroutine library, FOURIER PERSPECTIVE II advanced linear systems analysis.
• Menu driven software from Unilab, Laboratory Technologies, Quinn-Curtis, and Golden. Scientific engineering 2 & 3D graphics.

See "What's New" page 80, BYTE July, 1988
LOW PRICES—Satisfaction GUARANTEED

ALLIGATOR TECHNOLOGIES

P.O. Box 9706, Fountain Valley, CA 92708
Tel. (714) 850-9984 FAX. (714) 850-9987 MCI. ALLIGATOR

Inquiry 710.

POWERFUL EQN SOLVER

\$99 RISK FREE OFFER WITH FREE WORD PROCESSOR!
• "A real Bargain" IEEE • "Dev. over 40 years by aerospace vets"
• EE TIMES • Defines new functions" Eng'g Tools CURVE* • Graph results ACROSS SINGULARITIES • Change parameters/conditions
• Fit 60th order curves (polynomials) to imported data • COMPLEX/real roots • Coupled Diff Eq • Indefinite Integrals • More
• MS-DOS, 640k, graphics card

Call Today/800/621-0849 x 330

8:30-5:30 PTime • VISA/MC/AMEX/Check

Curve Systems International

747 Moreno Ave., LA, CA 90049

Inquiry 711.

C SCIENTIFIC LIBRARY

Extensive library of matrix, mathematical, and statistical routines. Developed and documented for use by technical specialists and C programmers in research, education, engineering, and scientific applications. Over 550 functions, superior documentation—four manuals, including Tutorial, Function Pages, and Example Programs. Includes Real and Complex Linear Algebra, Eigensystems, Differential Equations, Quadrature, Smoothing, Filtering and Prediction, Multi-Variate Statistics, Multi-Dimensional Optimization, Linear Programming, Curve Fitting and Interpolations, etc. \$295 object only and \$395 with C source code.

EIGENWARE TECHNOLOGIES

13090 La Vista Dr., Saratoga, CA 95070 (408) 867-1184

Inquiry 712.

ORDINARY/PARTIAL DIFFERENTIAL EQN SOLVER

FOR THE IBM PC & COMPATIBLES

MICROCOMPATIBLES INC.

301 Prelude Dr., Silver Spring, MD 20901
(301) 593-0683

Inquiry 713.

316 B Y T E • FEBRUARY 1989

SOFTWARE/SCIENTIFIC

OUR CATALOG WILL SAVE YOU TIME AND MONEY!

It describes (i) GRAPH, a \$79 scientific plotting program, (ii) MINSQ, a powerful \$179 package for curve fitting and model development, (iii) LAPLACE, a simulation program employing numerical inversion of transforms (\$149 until 3-1-89), and (iv) RSTRIP for exponential stripping (\$249). Call today for our free 16 page catalog with detailed technical application notes.

MicroMath Scientific Software

Salt Lake City, Utah 84121-3144

For orders or catalogs call: (800) 942-MATH

Inquiry 714.

Scientific/Engineering/Graphics Libraries Turbo Pascal, Turbo C, Microsoft C

Send for FREE catalogue of software tools for Scientists and Engineers. Includes: Scientific subroutine libraries, device independent graphics libraries (including EGA, HP plotter and Laserjet support), scientific charting libraries, 3-D plotting library, data acquisition libraries, menu-driven process control software. Versions available for a variety of popular languages.

Quinn-Curtis

1191 Chestnut St., Unit 2-5, Newton, MA 02164
(617) 965-5660

Inquiry 715.

SUBPROGRAM LIBRARIES

Five volumes of source code: Math, Statistics, Graphics, DOS & BIOS & I/O functions. Spectroscopy. Up to 99% less user code with our fully tested library. Manuals with examples guarantee fast success. Portability insured for BASIC, PASCAL under MS-DOS, Mac-OS, VMS, HP300. Prices start \$145 per volume. 30 day \$ back. VISA/MC/PC.

Scientific LOGICS Inc.

21910 Alcazar Ave., Cupertino, CA 95014

(408) 446-3575 Compuserve 74017,663

Inquiry 716.

SOFTWARE/SECURITY

CodeSafe™ Virus Protection System

Protects all hard disks, any size • Detects any dormant virus • Protects all COM, EXE, and associated OVL files. Not just the system files (like other products) • Detects corruption of Boot sector, and DOS • Supports all PC/MS DOS machines • DOS 2.0 to 4.0 • Mono, Herc, CGA, EGA • Includes both 5 1/4" and 3 1/2" disks • Transparent to user • Warning windows will open, with options if a problem occurs • Memory resident approx. 10 to 20 K, depending on the number of files.

TOLL FREE TECH SUPPORT • 30 Day Money Back Guarantee
NOT COPY/PROTECTED \$69.95

ChrisWare, Inc.

15415 N. Eden Dr., Eden Prairie, MN 55346

TOLL FREE 1-800-325-8448 Visa and Master Card accepted

Inquiry 717.

PC Security Products

A complete line for: PC access, back-ups, modems, software piracy, virus detection, file encryption, and data protection. Featuring CodeSafe H/W copy protection with sophisticated file encryption. Brochures and Demos available.

Gamma Security Products

710 Wilshire Blvd., #609, Santa Monica, CA 90401
Tel: 213/394-8622 Fax: 213/395-4214 Tlx: 5106008273

Inquiry 718.

KEEP YOUR FILES TO YOURSELF

Protect from the competition all your PC/AT sensitive files. Use the ultimate data security program:

ENCRYPT

EASY! FAST! RELIABLE! No hard disk required. For extra safety, do all your file transfers using coded data.

ATTENTION: Coded data is unbreakable.

\$50 30 day \$ back

R. T. RATO

Est Luz, 173-3E 1600 LISBOA PORTUGAL

Inquiry 719.

SOFTWARE/SECURITY

HANDS OFF THE PROGRAM®

- Locks Hard Disk. - Restricts Floppy Use.
- Protects Subdirectories.
- Normal Use of DOS Commands and Application Software.
- IBM PC, XT, AT and True Compatibles.
- DOS V2.0 and Higher. Hard Disk System.
- Keep Other People's HANDS OFF Your System
- \$89.95 VISA/MC

SYSTEM CONSULTING, INC.

314 Canterbury Dr., Pittsburgh, PA 15238
(412) 963-1624

Inquiry 720.

SOFTWARE/SORT

OPT-TECH SORT/MERGE

Extremely fast Sort/Merge/Select utility. Run as an MS-DOS command or CALL as a subroutine. Supports most languages and filetypes including Btrieve and dBASE. Unlimited file sizes, multiple keys and much more! MS-DOS \$149. XENIX \$249.

(702) 588-3737

Opt-Tech Data Processing

P.O. Box 678 - Zephyr Cove, NV 89448

Inquiry 721.

SOFTWARE/STRATEGIC

WANTED: CEO, Compaq Corp. ...or Microsoft, or Chrysler, or Union Carbide, or Georgia Pacific, or...

Business Week's Business Advantage simulation software puts you behind the desk of some of the most powerful business leaders in America. You make the decisions, you deal with competition, you set the strategy, you face the consequences. This exciting simulation has fourteen Chief Executive positions open, and is available in both PC and Mac formats. Only \$69.95 puts you in one of their shoes. Additional cases available for only \$29.95 (plus \$5.00 shipping and handling). To order, or for more information, please call:

BUSINESS WEEK

c/o Strategic Management Group, Inc.
3624 Market Street, Philadelphia, PA 19104
1-800-445-7089

Inquiry 722.

SOFTWARE/TAX PREP

TAX PAK

5th year—Sched A B C D E F R S Frms 1040 1040A
1065 2106 2119 2441 3468 3800 3903 4137 4562 4684
4797 4972 6251 6252 8582 8606 8615. IRS approved
printing for IBM PC. Professional allows multiple clients,
Batch Processing, & Tax Organizer: \$185. Personal has
abbreviated list of forms & features \$37. Annual updates
\$125 & \$27 respectively.

Candelaria Works

3955 Club Dr., Atlanta, GA 30319 (404) 266-2420

Inquiry 723.

W-2 & 1099 ON FLOPPY

The MAG COLLECTION of programs make an IRS/SSA FORMAT floppy from a data entry screen or imported ASCII file. Includes manual and application forms.

• Used nation wide • Menus, user friendly
• Step-by-step data entry • Prints W-2 & 1099
• Free phone support • PC compatible

Illinois Business Machines Inc.

Department MAG
1403 Box 310 Troy Rd., Edwardsville, IL 62025
PH. # (618) 692-6060

Inquiry 724.

APRIL 15th™

Tax preparation package based on Lotus 1-2-3, 2.0 for IBM-compatible PC w/512K. Includes 1040, 1040A, all Schedules & 12+ supporting Forms. IRS-acceptable printouts (except 1040, 1040A). Easy-to-use menu functions & Help files, 1988 Version \$49.95. Low-cost '87 demo available for '88 tax planning.

JD Enterprises

P.O. Box 658 St. Ann MO 63074
(314) 427-3353

Inquiry 725.

THE BUYER'S MART

SOFTWARE/TAX PREP

1988 TAXES FAST, EASY, ACCURATE

IBM/Compatibles, Commodore-Amiga. Prints forms, audits taxes, multiple returns, 20 forms and schedules, saves to disk, forecast 1989 taxes. ONLY \$34.95. Add \$4 S/H, MA add 5% Sales Tax, Check, M.O., Credit Cards.

Quality Business Systems

P.O. Box 805, Hudson, MA 01749
1-800-225-5800

Inquiry 726.

STATISTICS

STATA

NEW RELEASE NOW AVAILABLE. Even better graphics, expanded on-line help, and much more. Still only \$590. Quantity and Academic Discounts available. \$20 Demo. Call toll-free for more information. AX/VISA/MC.

1-800-STATAPC Computing Resource Center

10801 National Boulevard, Los Angeles, CA 90064
(213) 470-4341

Inquiry 727.

THE SURVEY SYSTEM

An easy-to-use package designed specifically for **questionnaire data**. Produces banner format, cross tabs & related tables, statistics (incl. regression) & bar charts. Codes and reports answers to open-end questions. All reports are camera-ready for professional presentations. CRT interviewing option.

CREATIVE RESEARCH SYSTEMS

15 Lone Oak Ctr., Dept. B, Petaluma, CA 94952

707-765-1001

STATISTICS CATALOG!

If you need statistics for IBM PC or Apple II, call us and let our technical advisors help you find the statistics programs you need. Write or call now to get a FREE catalog of statistics and quality control software.

HUMAN SYSTEMS DYNAMICS

9010 Reseda Blvd., Ste. 222
Northridge, CA 91324

(800) 451-3030 (818) 993-8536 (CA)

Inquiry 728.

STATISTICAL NAVIGATOR™

Statistical Navigator an expert system using AI strategies to help guide the researcher to the appropriate statistical analysis. Based on your answers, it suggests several analyses ranked by suitability. It explains what the analysis does and how it fits your objectives and assumptions. Special intro price \$99.95 + s/h.

VISA/MC/AMEX/PO, 30 day-guarantee.

The Idea Works, Inc.

100 West Briarwood, Columbia, MO 65203
1-800-537-4866 314-445-4554

Inquiry 729.

SIR/DBMS DEMO KIT (7.5 Mb) \$49.95

Since 1976, SIR/DBMS has PIONEERED Advanced DBMS Technology DESIGNED to handle the changing complexities of Scientific, Engineering, and Research Database Management. SIR/DBMS is also DESIGNED to Provide THE BEST DIRECT Interfaces to SAS, SPSS, BMDP, & SYSTAT. SIR/DBMS offers True Application Level Portability from PCs thru Supercomputers!

MAYBE YOU SHOULD TRY SIR/DBMS??

Order Now! Ref Buyer's Mart Special Offer!

SIR, A Division of Inter Systems Inc.

312-480-9270 (IL) 703-642-1600 (VA)

Inquiry 730.

STATISTICS

MINITAB's a PC of cake!

MINITAB's intuitive commands are easy to use and remember. Features descriptive statistics, regression, time series, chi-square, hi-res graphics, much more. PC version incl. LOTUS interface, 30-day trial, network pricing. Call for FREE brochure.

Minitab, Inc.

3081 Enterprise Dr., State College, PA 16801
(814) 238-3280

Inquiry 731.

NCSS

Professional, easy to use, menu driven statistical system. Used by over 5,000 researchers.

- 5.0 Statistical System —\$99
- 5.1 Graphics (2D & 3D)—\$59
- 5.3 Power Pac Supplement—\$49
- 5.4 Exp. Design/QC—\$49
- 5.5 Survival Analysis—\$59

We accept checks, P.O.'s, Visa, MC. Add \$3 s/h.

NCSS-B

865 East 400 North, Kaysville, UT 84037
801-546-0445

Inquiry 732.

STATISTIX™ II

Comprehensive, powerful and incredibly easy-to-use. Full screen editor, transformations, linear models (ANOVA, regression, logit, PCA, etc), ARIMA, most standard stat procedures. Clear, well organized documentation. Satisfaction guaranteed. \$169 PC DOS, \$99 Apple II.

NH ANALYTICAL SOFTWARE

P.O. Box 13204, Roseville, MN 55113

(612) 631-2852

Inquiry 733.

A-Cross

This year's #1 Cross Tab package!

Easy to learn & easy to use. Superfast, Supereasy "Point & Pick" operation. #1 in connections, statistics and tabulation features. Output to Lotus:WKS files, ASCII, and laser printers. #1 with leading market research firms and Fortune 500 companies. Accepts dBase, ASCII & Column-binary data. CALL FOR INFO AND FREE DEMO DISK

STRAWBERRY SOFTWARE

42 Pleasant Street, Watertown, MA 02172

(617) 923-8800 or FAX: (617) 926-0134

Inquiry 734.

StatPac Gold™

Voted World's Best Statistical & Forecasting Package in 1987 by PC World Magazine readers. Six times more votes than the next closest competitor. More comprehensive & easier to use than all others. Get the facts. Call now for your FREE brochure.

1-800-328-4907

Walonic Associates, Inc.

6500 Nicollet Ave. S., Minneapolis., MN 55423
(612) 866-9022

Inquiry 735.

UTILITIES

VIDEO SYSTEM TEST

This menu-driven utility tests your PC/XT/AT video monitor and controller board combination for compatibility with 17 video modes, including 8514/A, VGA, EGA, CGA, and Hercules. Also provides test pattern for screen adjustment. \$25.

Adventa Corporation

1016 E. El Camino Real, Ste 223, Santa Clara, CA 94087

(408) 946-8545

Inquiry 736.

UTILITIES

MATCH PRINTERS TO PC

For less than \$30 MatchFont and Match-a-Printer are great for foreign and scientific writings. Get all the characters you need from most programs and printers (Apple & Epson printers, daisywheels, etc.). Greek, French, Italian, Spanish, German, Swedish, Japanese, graphics... You name it! To receive a demo disk send \$5 refundable upon purchase to: Call or write 818-906-6791

MATCH SOFTWARE

6426 Coldwater Canyon, North Hollywood, CA 91606-1113

Inquiry 737.

ATTENTION FORMAT VICTIMS!!!

REARGUARD password protects you from accidental formatting of your hard disk. Not memory resident nor modifies DOS. Completely automated installation. Manual and diskette provided.

ONLY \$29.00 + \$4.00 S/H VISA/MC/COD UPS B/R

MICROBRIDGE COMPUTERS

655 Sky Way #125, San Carlos, CA 94070

Order toll free 1-800-523-8777

415-593-8777 (CA)

212-334-1858 (NY)

TELEX EZLINK 62873089

FAX 415-593-7675

Inquiry 738.

COPY AT TO PC

The 1.2MB drive has long been known to READ but NOT reliably WRITE on 360kB floppies. With "CPYAT2PC"™ 1.2MB drives CAN reliably WRITE 360kB floppies saving a slot for a second hard disk or backup tape. "CPYAT2PC" (Not Copy Protected) offers the preferable SOFTWARE SOLUTION! ONLY \$79 + \$4 S/H VISA/MC/COD UPS B/R

MICROBRIDGE COMPUTERS

655 Skyway, San Carlos, CA 94070

Order toll free 1-800-523-8777

415-593-8777 (CA)

212-334-1858 (NY)

TELEX EZLINK 62873089

FAX 415-593-7675

Inquiry 739.

Recover deleted files fast!

Disk Explorer now includes automatic file recovery. You type in the deleted file's name. Disk Explorer finds and restores it. Disk Explorer also shows what's really on disk: view, change or create formats, change a file's status, change data in any sector. MS-DOS \$75 U.S. Check/Credit card welcome.

QUAID SOFTWARE LIMITED

45 Charles St. E. 3rd Fl.

Toronto, Ontario, Canada M4Y 1S2

(416) 961-8243

Inquiry 740.

XPage Breaks 640k!

Why buy expensive EMS boards? OS/2 is not going to use it. XPage turns your PC/XT/AT hard disk space or AT extended memory as EMS memory. It's compatible with most DOS EMS applications. Write for free information or send check/money order \$39 + \$3 s/h to:

RMC Technologies

7 Baron Park La., #21, Burlington, MA 01803

(617) 272-8208

Inquiry 740.

LOGGER®

Logger, for IBM-PC and compatibles, tracks and reports: User, Time on, Time off, Directories used, Programs used, Program start/end time, and calculates totals. Tracks directories/files: Opened, Created, Renamed, Deleted. Completely transparent. Retail for \$74.95 with quantity discounts available.

System Automation Software, Inc.

8555 16th St., Silver Spring, MD 20910

1-800-321-3267 or 1-301-565-8080

Inquiry 741.

THE BUYER'S MART

UTILITIES

\$79.95!!

Order the RED Utilities now! Programs include: Disk cache speeds hard and floppy disks. Printer spooler. Batch file compiler speeds batch files. Path command for data files. Wild card exceptions. Sort directories. Over 10 more programs. IBM PC. Visa/MC. Send for free catalog.

The Wenham Software Company
5 Burley St., Wenham, MA 01984 (508) 774-7036

Inquiry 742.

WORD PROCESSING

DuangJan

Bilingual word processor for English and: Armenian, Bengali Euro/Latin, Greek, Hindi, Khmer, Lao, Punjabi, Russian, Sinhalese, Tamil, Thai, Viet... \$109+\$5 s/h (foreign + \$12 s/h). Font editor included. For IBM with dot-matrix & LaserJet printer. Demo \$6 + \$1 s/h.

MegaChomp Company

3524 Cottman Ave., Philadelphia, PA 19149-1606
(215) 331-2748

Inquiry 744.

WORD PROCESSING

PC-Write 3.0 — Shareware

Fast, full featured word processor for IBM PC. Now edits large files & multiple columns. Also spell check, mailmerge, networking, ASCII, and macros. Easy to use, optional menus. Supports 500 printers incl. lasers. Software, guide and tutorial on disk: \$16. Registration with manual, support newsletter and 2 free updates: \$89.

90 day money back guarantee. VISA/MC.

Quicksort

1-800-888-8088
219 First Ave. N., #224-BYTC, Seattle, WA 98109

Inquiry 745.

WORD PROCESSING

FARSI / GREEK / ARABIC / RUSSIAN

Hebrew, all European, Scandinavian, plus either Hindi, Punjabi, Bengali, Gujarati, Tamil, Thai, Korean, Viet, or IPA. Full-featured multi-language word processor supports on-screen foreign characters and NLQ printing with no hardware modifications. Includes Font Editor. \$355 dot matrix; \$150 add'l for laser; \$19 demo. S/H in U.S. incl'd. Req. PC, 640K, graphics. 30 day Guarantee. MC/VISA/AMEX

GAMMA PRODUCTIONS, INC.

710 Wilshire Blvd., Suite 609, Santa Monica, CA 90401
213/394-8622 Tlx: 5106008273 Gamma Pro SNM

Inquiry 743.

YOUR SALES MESSAGE

about the special computer product or service that you provide belongs in print.

THE BUYER'S MART

can help you reach computer professionals and produce valuable inquiries for your company!

Call Brian Higgins for more information

603-924-3754

GRAPHICS LIBRARIES

GRAPHICS LIBRARIES

Very Fast 2D/3D Autoscaling Graphics for Microsoft Languages. 3D Lines Use Color. Fast Polygon Fill, Solid/Wireframe. Color/Blinking Text. X-Y, Bar, Contour & 3D Fishnet Graphs. Supports CGA/EGA/VGA/Herc & Dot Matrix/Laser/Plotters (a Full Resolution. Print Screen. Port. \$140 NO ROYALTIES. FORTRAN Source + \$30.

CHIRP TECHNICAL SERVICES

P.O. Box 551, Del Mar, CA 92014-0551
(619) 632-9510

Inquiry 746.

	1985	1986	1987	1988	1989
Jan.	\$4.00			\$6.00	\$6.00
Feb.	\$4.00	\$6.00	\$6.00		
March	\$4.00	\$6.00	\$6.00	\$6.00	
April	\$4.00	\$6.00	\$6.00		
May	\$4.00	\$6.00		\$6.00	
June	\$4.00	\$6.00	\$6.00	\$6.00*	
July		\$6.00	\$6.00	\$6.00	
Aug.	\$4.00	\$6.00	\$6.00	\$6.00	
Sept.	\$4.00	\$6.00	\$6.00	\$6.00	
Oct.	\$4.00	\$6.00	\$6.00	\$6.00	
Nov.	\$4.00			\$6.00	
Dec.	\$4.00	\$6.00	\$6.00	\$6.00	

* Benchmarks Issue 1/2 Price

Check enclosed

Payments from foreign countries must be made in US funds payable at a US bank.

VISA MasterCard CARD # _____

EXP. DATE _____

SIGNATURE _____

The above prices include postage in the US. Please add \$.50 per copy for Canada and Mexico; and \$2.00 per copy to foreign countries (surface delivery). Please allow 4 weeks for domestic delivery and 12 weeks for foreign delivery.

European customers please refer to Back Issue order form in International Advertising section of book.

NAME _____

ADDRESS _____

CITY _____

STATE _____

ZIP _____

BACK ISSUES FOR SALE

SPECIAL ISSUES and INDEX

BYTE '83-'84 INDEX	\$3.00
BYTE 1985 INDEX	\$3.00
BYTE 1986 INDEX	\$3.00
BYTE 1987 INDEX	\$3.00
1985 INSIDE THE IBM PCs	\$4.00
1986 INSIDE THE IBM PCs	\$5.00
1987 INSIDE THE IBM PCs	\$6.00
1988 INSIDE THE IBM PCs	\$6.00
APPLICATIONS SOFTWARE TODAY SPECIAL	\$4.00

Circle and send requests with payments to:

BYTE Back Issues
One Phoenix Mill Lane
Peterborough, NH 03458
(603) 924-9281

Special !
CompuGUARD

Anti-VIRUS ... \$75
Access Control ... \$129

Best Buy
see Floppy Drives

**SAVE UP
TO 70%**
SINCE 1984



THE PRIMITIVE DRAUGHTSMAN

PRODUCTS NOT LISTED ... CALL!

CAD...etc.
PC & MAC

New Orders: 1-800-621-3999

AST Premium
286/386
Call

ZENITH 1490
FlatScreen
\$579

DRAFIX
Ultra, 1 Plus or 3D Module
Call

MITSUBISHI
Diamond Scan AT 40Mb Disk
\$477 \$379

VENTURA **PAGE-MAKER**
PUB 2.0
\$457 Call

Summagraphics
Mac 12x12 Tablet
\$269

DESIGN CAD
Standard or 3D
\$145

SMART MODEM
1200B int. 2400B int.
\$59 \$115

PANASONIC
1091I-m2 1124
\$179 Call

SCANNERS
ScanMan or Complete PC
HandScanner
\$155

PRINTERS & LASERS

Alps	Call
Canon BJ-130	Call
Citizen 180-D	157
MSP-15E	295
MSP-40	269
MSP-45	389
MSP-50	345
MSP-55	440
Premiere 35	439
Tribute 124	439
Tribute 224	579
Diconix 150	295
HP LaserJet II	1690
JDL 850 Series	Call
NEC LC890	Call
Panasonic 1080i-m2	155
1091i-m2	189
1124	Call
1592/1595	382/418
1524	415
Toshiba 321-SL	555
341-SL	609
351-SX	888
Others	Call

SOFTWARE (cont.)

Excell PC	281
FastBack	69
FastBack Plus	85
FormTool	52
Freelance Plus	293
Fox Base Plus	179
GEM Draw Plus	159
Generic Cadd 3.0	48
Generic Cadd Others	Call
Harvard Graphics	255
In House Acct	107
King Quest IV	35
Laplink Plus	74
Liesure Suit Larry II	35
Lighting Hard Disk Speedup	59
Lotus 123 2.01	Call
Lotus Agenda	Call
Managing Your Money	113
MathCad 2.0	195
MicroSoft Flight Sim	35
MicroSoft Windows 2.0	56
MS-Dos 3.3	95
Norton Util 4.0	45
Novell Netware 286	Call
PageMaker 3.0	Call
Paradox 2.0	391
PC Tools Deluxe	Call
PathMinder 4.0	55
Peachtree Accounting II	145
Peachtree Quere	Call
PFS: First Choice 3.0	85
PFS: First Publisher 2.0	67
PFS: Professional File 2.0	Call
PFS: Professional Plan 1.02	51
PFS: Professional Write 2.0	102
Plan Perfect	185
Q&A	177
Q&A Write	115
Quattro	132
Rapid File	172
R:Base for DOS	415
ShipMate™ (ups Manifest)	199
SideKick Plus	Call
Smart System	418
Sprint	115
Tops	101
Turbo Basic, C, or Pascal	85
Ventura Publishing 2.0	458
VersaCad & Libraries	Call
Windows	Call
WordPerfect 5.0	213
XTree	93
XTreePro	58
XTreeNet	Call

HITACHI Digitizer
10 Year Warranty
Puma Pro 12x12
(replacing Tiger Tablet)
4-Btn Cursor, 1-Btn Pen
& Mouse Emulator.
\$349

Digitizers & Plotters (cont.)

DMP 51MP	3550
DMP 51	3200
DMP 52MP	2600
DMP 52	2300
DMP 56A	3800
DMP 61	2890
DMP 62	3990
MP Options	Call
Hitachi Puma Tab (10-Year Warranty)	Call
PumaPro 12x12,4btn,Pen,SW	349
PumaPro 12x12,12btn,SW	369
Ioline	Call
JDL 850 Series	Call
Kurta IS 12x12	285
IS 12x17	485
Summagraphics 12x12 Plus	329
18x12 Pro w/4 Butt & Stylus	559
Mac Bit Pad 12x12, 4But, Sty	269

DRIVES, MODEMS & FAX

Fujitsu 3.5" 720k Drive	84
Mitsubishi AT 40/64 Mb Hard Drive	379
1/2 ht, 23ms	379
Panasonic FAX Board	689
Seagate ST225 w/card	260
ST238 30Mb w/card	285
Sharp Fax UX-140 & Phone	969
Smart Modem 1200B int w/sw	58
2400B int w/sw	115
Teac 3.5" 720k Drive	79
3.5" 1.44Mb Drive	95
5.25" 360k Drive	75
5.25" 1.2Mb Drive	87
US Robotics	Call

COMPUTERS

AST Premium	1349
286 Model 80	2098
286 Model 140X	2098
386 Model 300	2475
Mitsubishi MP286L	Call
NEC Multispeed	1079
Multispeed EL II	1423
Multispeed HD	2209
Toshiba Laptops	Call
T1000	779
Zenith Laptops	Call
SuperSport-Dual	1570
SuperSport 20Mb	2357
SuperSport 286 20Mb	3298
SuperSport 286 40Mb	Call

MONITORS

Arndek 1280 & Card	639
210A	87
Hitachi 20" SuperScan	2090
Mitsubishi Diamond Scan 1381	477
Monitorm Viking	Call
NEC Multisync II	565
Multisync GS	185
Others	Call
Samsung	Call
Sigma Designs LaserView	Call
Sony Multiscan 1302	650
Multiscan 1303	475
Zenith 1490 FlatScreen	579

SOFTWARE

AutoSketch®	59
BoeingGraph	189
By-Line	169
Carbon Copy Plus	103
Clipper	369
Copy II PC	18
Corefast	75
Dac Easy 3.0	58
dBase IV	Call
DesignCad	145
Desklink	92
DesqView	69
Drafix 1 Plus	Call
Drafix Ultra	Call
Drafix 3D Mod & Options	Call
Dollars & Sense	95
Easy Xtra	54



T-1000
\$779

HELPERS

Logical Connection 256/512k	Call
Others	Call
ScanMan	155

Clones 286/386Call

WANTED
Original Programs - utilities, applications, etc. Earn royalties in just 90 days.
Mail or Fax your info to attn: Bill. MS-DOS & MAC compatible only.

BOARDS & NETWORKS

3-Com Etherlink	Call
Adage AD10/4	Call
AD10/8L	Call
ArcNet	Call
Artist	Call
AST	Call
ATI EGA Wonder	169
VIP VGA	249
Copy II Opt Board Dix	95
EtherNet Plus	Call
Genoa VGA 760x1024	379
Hercules Graphics Plus	169
Intel AboveBoard 286/512k	359
AboveBoard PS 286/512k	388
Paradise EGA 480	Call
VGA Plus	Call
VGA Plus 16	Call
VGA Pro	Call
Sigma Designs VGA	209
Tops Flashcard	143
Verticom	Call
Video 7 Vega Deluxe	177
V-Ram	Call
Vega VGA	\$255
Western Digital EtherNet Plus	Call

Intel coprocessors
Genuine & New

8087-2	132
80287-8	205
80287-10	239
80387-16	Call
80387-20	Call
80387-25	549
80387-SX	398
80C287A (for Laptops)	299

MOUSE

Logitech C7 Serial or Bus	64
C7 Clear Mouse & Paint	85
HiRez Bus	82
Bus & Paint	82
Serial & Publisher	104

OPTICAL

OptiDriver Kit	525
40 ms equiv. for most optiDrives	

DataBase Special

dBase IV ...	455
FoxBase Plus ...	179
Paradox ...	429
Rapid File ...	175
Rbase for DOS ...	415
Q & A ...	177
Quattro ...	149

MHI Warehouse, Inc.
8129 N. 35th Ave. #2-306
Phoenix, AZ 85051
New Orders:
1-800-621-3999
Order Info: 602-997-8877
Fax: 602-943-3833

It PAYS to BUY-MHI!
Service You Expect !!
Volume Bids Welcome!
VISA
MASTERCARD
PO's
Just Call First.

Pre-approved P.O.'s are welcome. Prices reflect cash discount and are subject to change without notice. Product compatibility, warranties, & claims are responsibility of manufacturer only. All returns are subject to a restocking fee. Personal/Company checks delay shipping. AZ orders only add 6.7% tax. Orders are processed same Day. International orders Call (602) 861-1090.

Worldwide • Since 1974

• QUALITY COMPONENTS • COMPETITIVE PRICING
• PROMPT DELIVERY



COMPUTER PRODUCTS

Jameco IBM AT Compatible 16MHz 80286 NEAT Motherboard

- Expandable to 8MB RAM (Zero-K included)
- 8/12 or 8/16MHz switchable
- Supports all NEAT functions including shadow RAM, EMS 4.0, RAM re-mapping and selectable wait states
- 80287-10 Coprocessor capability
- Norton SI rating of 15.6
- AMI BIOS ROMs included
- One-year warranty



JE3010 8/12/16MHz NEAT (AT) . . . \$469.95

— Additional Motherboards —

- JE1001** 4.77/8MHz (PC/XT) \$ 89.95
JE1002 4.77/10MHz (PC/XT) \$109.95
JE3005 8/12MHz (AT) \$329.95

Jameco IBM PC/XT/AT Compatible Computer Cases



JE1019 Pictured

- JE1010** Standard PC/XT Flip-Top Case . . . \$34.95
JE1011 Standard PC/XT Slide Case \$39.95
JE1014 Baby XT Turbo Flip-Top Case . . . \$69.95
JE1017 Baby AT Flip-Top Case \$54.95
JE1018 Baby AT Slide Case \$69.95
JE1019 Baby AT Flip-Top Case \$69.95

TEST EQUIPMENT

Metex M4650:

- Handheld, high accuracy
- 4 1/2 Digit LCD
- Manual ranging with Overload Protection
- Audible continuity tester
- Tests: AC/DC Voltage, Resistance, Continuity, Capacitance, Frequency
- One Year Warranty
- Size: 7L x 3.5W x 1.5H



M4650 . . . \$99.95

JAMECO SOLDERLESS BREADBOARD SOCKS

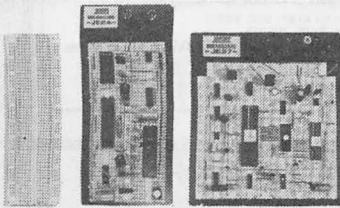

Part No.	Dim. L" x W"	Contact Points	Binding Posts	Price
JE20	6 1/2 x 3/4	200	0	\$ 1.95
JE21	3 1/4 x 2 1/2	400	0	\$ 4.95
JE22	6 1/2 x 1 3/8	630	0	\$ 5.95
JE23	6 1/2 x 2 1/2	830	0	\$ 7.95
JE24	6 1/2 x 3 1/8	1,360	2	\$14.95
JE25	6 1/2 x 4 1/4	1,660	3	\$22.95
JE26	6 7/8 x 5 3/4	2,390	4	\$27.95
JE27	7 1/4 x 7 1/2	3,220	4	\$37.95

DATA BOOKS

- 400041** NSC Linear Data Book-Vol. I (88) . . . \$14.95
400042 NSC Linear Data Book-Vol. II (88) . . . \$ 9.95
400043 NSC Linear Data Book-Vol. III (88) . . . \$ 9.95
210830 Intel Memory Handbook (88) \$17.95
230843 Intel Microsystem Hndbk. Set (88) . . . \$24.95

Jameco IBM PC/XT 8MHz Turbo Compatible Kit With 256K RAM

- Free! QAPLUS Diagnostic Software Included!
- Free! PC Write Word Processing Software Included!
- 256K RAM Included, Expandable to 640K
- 4.77 or 8MHz Switchable
- AMI BIOS ROM Included
- Save \$128.06



Build Your Own And LEARN!

Part No.	Description	Price
JE1001	4.77/8MHz Turbo Motherboard (Zero-K RAM — includes AMI BIOS ROM)	\$89.95
JE1010	Flip-Top Case	34.95
JE1015	XT/AT Compatible Keyboard	59.95
JE1020	5.25" DSDD Disk Drive (Black Bezel)	89.95
JE1030	150 Watt Power Supply	59.95
JE1040	360K Floppy Controller	29.95
JE1050	Mono/Graphics Card with Printer Port	59.95
AMBER	12" Monochrome Amber Monitor	99.95
41256-150	256K RAM (9 chips)	103.41

Save \$128.06 Regular List \$628.01
JE3002 IBM Compatible PC/XT 8MHz Turbo Kit . . . \$499.95

IBM COMPATIBLE DISPLAY MONITORS

- AMBER** 12" Amber Monochrome . . . \$99.95
CTX2410 14" RGB Color \$279.95

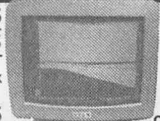

- 14" EGA Color - EGA/CGA Compatible, 720 x 350 Max. Resolution (PC/XT/AT)**
TM5154 \$399.95
14" EGA Monitor and EGA Card - EGA compatible, 720 x 350 Max. Resolution — displays up to 16 colors (PC/XT/AT)
JE1059 SAVE \$40.00 \$519.95
TM5155 14" Multiscan Color \$499.95
QC1478 14" VGA Monitor \$449.95
14" VGA Monitor and VGA Card - QC1478 VGA Monitor and Orchid VGA Card (PC/XT/AT)
JE2055 SAVE \$70.00 \$649.95

JAMECO IBM PC/XT/AT COMPATIBLE CARDS

- Graphic Display Cards**
JE1050 Mono Graphics Card w/Printer Port (PC/XT/AT) . . . \$59.95
JE1052 Color Graphics Card w/Printer Port (PC/XT/AT) . . . \$49.95
JE1055 EGA Card with 256K Video RAM (PC/XT/AT) . . . \$159.95
JE1071 Multi I/O with Drive Controller and Mono Graphics (PC/XT) . . . \$119.95

Multifunction, I/O and Expansion Cards

- I/O Card with Serial, Game, Parallel Printer Port and Real Time Clock (PC/XT) . . . \$59.95
JE1060 RS232 Serial Half Card (PC/XT) \$29.95
JE1061 RS232 Serial Half Card (AT) \$34.95
JE1062 I/O Card w/Serial, Game & Parallel Printer Port (AT) . . . \$59.95
JE1065 2MB of expanded or extended memory (zero-K on-board) (AT) \$119.95
JE1081 3MB of expanded or extended memory, parallel printer port, serial port and game port (zero-K on-board) (AT) \$169.95
JE1082

Floppy and Hard Disk Controller Cards

- JE1041** 20/40MB Hard Disk Controller Card (PC/XT) \$79.95
JE1043 360K/720K/1.2MB/1.44MB Floppy Disk Cont. (PC/XT/AT) \$49.95
JE1044 360K Floppy/Hard Disk Controller Card (PC/XT) . . . \$129.95
JE1045 360K/720K/1.2MB/1.44MB Floppy/Hard Disk Controller Card (AT) \$149.95

COMPUTER PERIPHERALS

AMI 80386 Motherboards

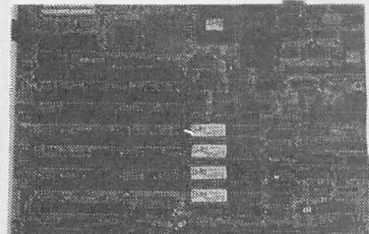

- Expandable to 2MB (Zero-K incl.) of 32-bit RAM with expansion board (included) • Expand an additional 8MB using the JE3030 (below, Zero-K incl.)
- XT footprint-AT compatible • 80387-16/20 capability • Built-in set-up and diagnostics • Includes AMI BIOS ROMs • One-year warranty

- JE3020** 16MHz 80386 (AT) . . . \$1199.95
JE3025 20MHz 80386 (AT) . . . \$1499.95
JE3030 8MB (Zero-K) Daughterboard . . . \$249.95

Seagate 20,30 40 and 60MB Half Height Hard Disk Drives



- ST225** 20MB Drive only (PC/XT/AT) . . . \$224.95
ST225XT 20MB w/Controller (PC/XT) . . . \$269.95
ST225AT 20MB w/Controller (AT) \$339.95
ST238 30MB Drive only (PC/XT/AT) . . . \$249.95
ST238XT 30MB w/Controller (PC/XT) . . . \$299.95
ST238AT 30MB w/Controller (AT) \$389.95
ST251 40MB Drive only (PC/XT/AT) . . . \$379.95
ST251XT 40MB w/Cont. Card (PC/XT) . . . \$419.95
ST251AT 40MB w/Controller Card (AT) . . . \$489.95
ST251-1 40MB Fast 28ms (Drive only) . . . \$469.95
ST277 60MB Drive only (PC/XT/AT) . . . \$449.95
ST277XT 60MB w/Controller (PC/XT) . . . \$499.95
ST277AT 60MB w/Controller Card (AT) . . . \$589.95

- 40MB Tape Back-Up for IBM PC/XT/AT**
DJ10 40MB Back-Up and Tape . . . \$349.95
TB40 40MB Tape Cartridge \$24.95

Jameco 5.25" PC/XT & AT Compatible Disk Drives

JE1022 (Pictured)

- JE1020** 360K Black Bzl. (PC/XT/AT) . . . \$ 89.95
JE1021 360K Beige Bzl. (PC/XT/AT) . . . \$ 89.95
JE1022 1.2MB Beige Bzl. (PC/XT/AT) . . . \$109.95

3.5" PC/XT/AT Compatible Disk Drives

- 352KU** 3.5" 720KB (Mounting Frame Included) (PC/XT/AT) \$109.95
356KU 3.5" 1.44MB (Mounting Frame Included) (PC/XT/AT) \$129.95

Datronics

2400/1200/300 Modems

NEW, Pocket Version!

- Hayes command compatible • Bell 103/212A compatible • Auto-dial/auto-answer • FCC approved 1-year warranty • Includes MaxiMite Communication Software (except 1200P)

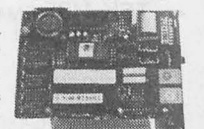

- 1200P** 1200/300 Baud Pocket Modem . . . \$ 99.95
1200H 1200/300 Baud Internal Modem . . . \$ 69.95
2400H 2400/1200/300 Internal Modem . . . \$129.95
1200C 1200/300 Baud External Modem . . . \$ 99.95
2400C 2400/1200/300 External Modem . . . \$169.95

U.S. Funds Only
 Shipping: Add 5% plus \$1.50 Insurance
 (May vary according to weight)

California Residents:
 Add 6%, 6 1/2% or 7%
 Sales Tax



\$20 Minimum Order
 IBM is a registered trademark of International Business Machines



Data Sheets — 50¢ each
 Prices Subject to Change

Send \$2.00 Postage for a
 FREE 1989 CATALOG

FAX Numbers: 415-592-2503
 or 415-592-2664

Telex: 176043

1355 Shoreway Road, Belmont, California 94002

24 HOUR ORDER HOTLINE (415) 592-8097 • The Following Phone Lines Are Available From 7AM-5PM P.S.T.:

• Customer Service (415) 592-8121 • Technical Assistance (415) 592-9990 • Credit Department (415) 592-9983 • All Other Inquiries (415) 592-7108

Fix common problems fast!

You don't need to be an expert to diagnose and correct problems involving PC setup. All you need is HELPME™ software! More than 300 tests. On-screen help for understanding and correcting identified problems. Quick identification of system configuration and compatibility. \$99 plus shipping and handling. MC and VISA accepted. California Software Products, Inc., 525 N. Cabrillo Park Drive, Santa Ana, CA 92701 (714) 973-0440.

Circle 47 on Reader Service Card
(DEALERS: 48)



Sure it's insured?

SAFWARE® Insurance provides full replacement of hardware, media and purchased software. As little as \$39/yr. covers:

- Fire • Theft • Power Surges
- Earthquake • Water Damage • Auto Accident

For information or immediate coverage call:
1-800-848-3469

In Ohio call 1-614-262-0559

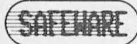

SAFWARE, The Insurance Agency Inc.

Circle 202 on Reader Service Card

Terminal Emulation

TEK 4105 EM4105 \$349

- Tektronix 4105
- Tektronix 4010
- VT220, VT102
- Picture files
- VGA and EGA support
- High resolution hardcopy

VT220 EM220 \$169

- VT220, VT102 emulation
- File transfer
- 132 column modes
- Color support
- Hot key

■ ■ ■ Diversified Computer Systems, Inc.

3775 Iris Avenue, Suite 1B
Boulder, CO 80301 (303) 447-9251
FAX: 303-447-1406

Trademarks: VT102, VT220 -- DEC, Tektronix -- Tektronics Inc.

Circle 78 on Reader Service Card

PDK51

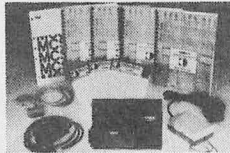

The \$595 Solution to 8051 Product Development

The PDK51 is a powerful and economical choice for the development of 8051-based systems. The PDK51 is used with an IBM-PC or equivalent and includes:

- SIBEC-II 8052 Basic Microcontroller
- SXA51 Cross Assembler
- ROM-Based Monitor/Debugger
- PROM Programmer
- Power Supplies
- Documentation, Tutorial and More

Call Now! (603) 469-3232



Binary Technology, Inc.

Main St., P.O. Box 67, Meriden, NH 03770

Circle 63 on Reader Service Card

HARD DRIVE SALE

SEAGATE

ST- 225	\$ 255.00
with controller and cable	
ST- 238	\$ 265.00
with controller and cable	
ST- 251	\$ 325.00
ST- 251-1	\$ 420.00
ST- 125	\$ 289.00
with controller and cable	
ST- 138	\$ 359.00
with controller and cable	



A.N. Wholesale & Retail, Inc.
1320 South Dixie Hwy. Suite 256
Miami, Fla 33146

Phone: (305) 284-0827

Fax: (305) 284-0831

Circle 27 on Reader Service Card

HARD DISK CONTROLLERS

ADAPTEC	
PC/XT Controller ST506/412	\$45
2070 PC/XT to 506/412 RLL	\$69
2071 PC/XT to ST506 RLL (1 drive)	\$59
2072 PC/XT RLL	\$79
2370 PC/XT to ST506 RLL	\$99
3530 SCSI to Tape CMC 36	\$78
4000 SCSI to ST506/412	\$89
4000A SCSI to ST506/412	\$129
4070 SCSI to ST506/412 RLL	\$98
4520 SCSI to ESDI	\$98
5500 SCSI to ST506/412	\$125
5580 SCSI to SMD	\$175
XEBEC	
SI1410 SASI Controller	\$89
SI1420 SASI to 5 1/4" Floppy & Hard Disk Controller	\$29
Apple II, II+, IIE Host Adapter	\$29
OTHERS	
DTC 510A SASI controller	\$98
DTC 5187 AT to ST506/412, No Floppy	\$98
Konrad DJ-210 3 1/2" SASI to ST506/412 (Xebec 1410 clone)	\$98
WD 1002-SHD Xebec Compatible SASI Controller	\$109
Western Digital 1003WAH	\$119
Manuals	\$8 each
Cables Available	Ask for Pricing
Hard Drives 20-380 MB	Call



Computer Surplus Store

715 Sycamore Dr. • Milpitas, CA 95035

Phone: 408-434-1060

Fax: 408-434-0931

Twx: 1561447

"We Buy and Sell!"

Circle 63 on Reader Service Card

9-TRACK MAG. TAPE SUBSYSTEM* FOR THE IBM PC/XT/AT AND...



For information interchange, backup and archival storage, AK Systems offers a 9-track, IBM format-compatible 1/2" magnetic tape subsystem for the IBM PC, featuring:

- IBM format 1600/3200 and 800 cpi.
- Software for PC-DOS, MS-DOS, XENIX.
- Also for AT&T, DEC, VAX, VME, S-100, RS-232, IEEE 488.

* formerly IBEX Mainstreamer

AKSystems

20741 Marilla St.
Chatsworth, CA 91311
(818) 709-8100
TWX: 910-483-2071

Write, phone or TWX for information.

Circle 11 on Reader Service Card

NEW FASTER EPROM PROGRAMMER



- Programs 2764 in 8 sec.
- Reads, programs, copies over 475 devices from 35 mfg.'s: 2716-2713, 27011, 68764, 68766, 2804-28256, etc.
- Optional microcontroller heads support 874x and 87C51 series
- Improved design now programs over twice as fast
- Automatically uses the fastest algorithm recommended by the manufacturer to ensure reliable data storage
- Connects via RS-232 to any computer: PC, XT, AT, PS/2, Mac, etc
- Supports XMODEM/XMODEM CRC protocols & ASCII file xfers
- Supports Intel, Motorola, hex-space, straight hex and binary files
- Checksums supported
- 30-day money-back guarantee
- Engr support team for fast updates
- One-year warranty (parts and labor)
- Toll-free technical support
- Thousands of satisfied customers attest to the EP-1's great value
- Low price of \$349 includes IBM compatible communications program, user's manual and two free firmware update coupons

CALL TODAY FOR MORE INFO 1-800-225-2102

BP MICROSYSTEMS

10681 Haddington #190, Houston, TX 77043
(713) 461-9430 FAX (713) 461-7413

Circle 40 on Reader Service Card

FRAME GRABBERS

MODEL	RESOLUTION	PRICE	PRICE
		with frame grab	without frame grab
HRT 256-4	256 x 256 x 4	495	NA
HRT 256-8	256 x 256 x 8	795	NA
HRT 512-8	512 x 512 x 8	995	NA
HRT 512-24	512 x 512 x 24	1995	1495

- CALL FOR DIFFERENT MODELS
- IBM PC/XT/AT COMPATIBLE
- DIGITALIZE IN REAL TIME
- COMPOSITE VIDEO IN
- 24 BIT RGB OUT except model HRT 256-4
- 16 level gray scale out
- SOFTWARE LIBRARY OF IMAGE ANALYSIS ROUTINES
- FREE SOFTWARE UPGRADES TO REGISTERED OWNERS
- FULL CREDIT ON UPGRADE PURCHASE IN FIRST YEAR
- RETURN OLD BOARD AND JUST PAY DIFFERENCE

INPUT DEVICES (optional)
Microsoft Mouse (bus or serial) \$99
Bit Pad Plus with Summagraphics \$359



HIGH RES TECHNOLOGIES
P.O. BOX 76
LEWISTON, N.Y. 14092

PHONE 416-497-6493

FAX 416-497-1988

Circle 105 on Reader Service Card

Compu\$ave



1-800-877-8855

International Orders are Welcome!

BOARDS

Adv. Dig. Slave 565 Orchid Tiny Turbo 286 259
 AST 5251-11E 545 Panasonic Fax 649
 AST Adv. Prem 309 Paradise VGA+ 269
ATI VGA Wonder ... CALL Paradise VGA Pro ... 395
 BOCA RAM AT 139 Sigma VGA H 238
Genoa VGA HiRes ... 349 STB VGA EM 512K ... 358
 Intel Above Board Call Video 7 V RAM 468
 Orchid Designer 325 Video 7 Fastwrite 345
 Adaptec, Artist, Hercules, Methues, Number 9 ... CALL
 Quadram, Talltree, West. Digita, /Verticom, VMI . CALL

DISK DRIVES

CDC 150 Mb 1,399 Plus Hardcard 40 638
 Bernoulli II 20 Mb 799 Seagate 20Mb Kit 262
 Miniscribe 3053 429 Seagate 30M bKit 275
 Miniscribe 6085 549 Seagate ST251-1 369
 Moutain TD 4440 365 Toshiba 720 K, 3.5" Kit ... 84
Plus Hardcard 20 ... 498 WORM Drives CALL
 AST, Archive, Alloy, Genoa, Micropolis CALL
 Maynard, Maxtor, Teac, Tecmar CALL

SOFTWARE

DBase III Plus & IV . CALL Paradox 2.0 412
 Enable 2.0 385 Project 4.0 310
 Foxbase Plus 194 Q & A 3.0 190
 Framework III 419 Quattro 138
 Harvard Graph 2.1 299 R:Base for OS2 545
 Lotus 123 279 Sprint 125
 Microsoft Excel-PC 289 Symphony 408
 Microsoft Works 95 Top for DOS CALL
 Microsoft Word 4.0 209 Ventura Publisher 489
 Multimate Advan. II 252 WordPerfect 5.0 217

COMPUTERS

Acer 1100 B4 3095 Toshiba 1000 798
 Acer 20 Mhz CALL Toshiba T1200F 1445
 AST Model 80 1465 Toshiba T1200HB 2465
 AST Model 300 2777 Toshiba 3100/20 2695
 AST Model 340 3995 Toshiba 3200 3750
 AST 3320 6935 Toshiba 5100 4899
 Intel 25 Mhz 3899 Toshiba 5200 CALL
 NEC 386: 2 Mb 2995 Wyse 2108 956
 NEC EL II 1465 Wyse 2112 1375
NEC Powermate ... CALL Wyse 2200 1345
 Packard Bell 12 Mhz . 1249 Wyse 3216 2125
 Samsung 20 Mhz 2845 Unisys 386 2695
 Samsung S500 AT ... 1029 Zenith Supersport 1599
 Televideo 386 2Mb ... 2565 Zenith Supersport 286 3395
Mitsubishi MP286: 12 Mhz / 40 Mb Drive 1799
Mitsubishi MP286 Laptop : 20 Mb 2298
 Sperry PC IT : 512kb / 44Mb HD / Keyboard 2795
 Altos, ITT, Sharp & Other Models CALL

TERMINALS

Adds 1010 299 Televideo 965 412
 Altos V 485 Wyse 30 279
IBM 3151 385 Wyse 50 355
 Kimtron KT-70 PC 359 Wyse 60 392
Link MC-5 409 Wyse 85G 359
Televideo 955 365 Wyse 99GT 457
 Visual, CIE, Link, Qume, Falco & Other Models CALL

MICE

Logitech C7 68 Microsoft w/ paint 99
 Logitech HiRes 92 Microsoft w/windows .. 129
 Mouse Systems PS/2 ... 95 Summa Mouse 78

PLOTTERS

Calcomp 1023GT 3785 HP 7550 A 2895
 Calcomp 1043 GT 5645 HP 7570A 3045
 Calcomp 1044GT 10,245 HP 7595 7795
 Calcomp Colormaster .. 3395 Ioline 3700 3065
 Houston DMP 52 2298 Ioline 4000 3995
 Houston DMP 41/42 2110 JDL 850 GL 2799
 Houston DMP 56A 3850 Roland 885 895
 Houston DMP 61 2999 Roland 980 1199
 Houston DMP 62 4095 Roland 990 1250
 HP 7475 A 1395 Roland GRX CALL
 Numonics, Taxan, Versatec, JDL, Other Models ... CALL

DIGITIZERS

Calcomp12 x12 348 Kurta IS 3 CALL
 Calcomp 44 x 60 3745 Kurta IS 8.5 x 11 245
 Calcomp36 x 48 3195 Kurta IS 12 x 12 309
 GTCO 24 x36 1945 Kurta IS 12 x 17 535
 GTCO 36 x 48 2395 Summa 12 x 12 + 348
 Hitachi 11 x 11 439 Summa 12 x 18 579

MODEMS

ATI 2400 ETC. 155 Practical 1200I 65
Anchor 2400E 145 Prometheus 2400B/2 ... 129
 Avatex 1200 Ext. 95 Prometheus 2400G 149
Cardinal 2400 Ext ... 139 Racal-Vadic 2400VP 388
Cardinal 2400 Int. 109 USR 2400E 345
 Hayes 1200 279 USR Courier 2400 299
 Hayes 2400 415 USR HST 9600 649
 Migent Pocket 109 Ven-Tel 2400 PS/2 275
Multitech 224 EH 388 Ven-Tel 18000 939
Multitech 224 EC 305 Zoom 2400 HC 145
 Case, Packard Bell, UDS, Other Models CALL

PRINTERS

Alps 324 E 739 Panasonic 1080IM2 165
 Alps Allegro 24 344 Panasonic 1091IM2 179
Canon BJ 130 719 Panasonic 1124 CALL
 Citizen120D 145 Panasonic P1592 368
 Citizen 180D 159 Star NX-1000 169
 Citizen MSP 40 312 Star NX-1000R Color . 299
 Fujitsu DL3400 525 Star NX-2400 318
 Okidata ML391 ... 649 Toshiba 321SL 469
 Okidata ML 393 . 989 Toshiba 341SL 629
NEC P2200 335 Toshiba P351SX 949
NEC P5200 506 Qume Script 10 CALL
NEC P5300 668 NEC LC 890 3165
 NEC P9XL 1038 HP Laser Jet II SAVE
 Brother, C.Itoh, Data Products, Diconic CALL
 Epson, Genicom, QMS, OTC, Varityper, TI CALL

MONITORS

Amdek 1280 638 Samsung TTI 79
 Gold Star TTL Mono 75 Seiko 1430 599
Mitsubishi 1381A 499 Sigma Laser 19" ... 1765
Mitsubishi 6905TK ... 2154 Sony Multiscan 675
NEC Multisync II 575 Tatung Multiscan 475
NEC Multisync + 915 Wyse 650 VGA 459
NEC Multisync XL ... 2029 Wyse 700 678
NEC Multisync GS ... 149 Wyse 7190 CALL
 PGS Ultra Sync 522 Zenith 1490 598
 PGS UltraSync 16" 895 Other Models CALL

SCANNERS

Datacopy Jetreader ... 545 Panasonic 505 969
 Logitech Scan Man ... 191 PGS LS-300+ OCR ... 965
 AST, HP, Taxan, PC Hard Scanner Call

Mail Address: 4207 S. 37th Street - Dept B2 - Phoenix, AZ 85040. HOURS: MON-FRI 7 AM-6 PM, SAT: 9 AM- 2 PM. Prices reflect cash discounts and are subject to change without notice. We do not guarantee compatibility. DOA's are repaired or replaced, please call for a RMA. Major credit cards and selected PO's are accepted.
INTERNATIONAL SALES (602)437-4855 - FAX (602)437-9685 - CUSTOMER SERVICE (602)437-4856.

COMPARE OUR NEW LOWER PRICES AND SUPERIOR QUALITY

PCI-286-12

- 80286-12
- 1.2 MB Floppy Drive
- 640K RAM
- Serial / Parallel / Game
- 101-Key Enhanced Key Board
- SI = 13.3 (1 Wait)
- SI = 15.2 (0 Wait \$100 Option)
- 6/12 MHz Key Board Switchable
- WA2 HD & FD Controller
- 80287 SOCKET
- 200W POWER SUPPLY

MONO SYSTEM

- W/Mono Monitor
- 20 MB Hard Disk

\$1195

VGA COLOR SYSTEM

- W/VGA Card & Monitor
- 20 MB Hard Disk

\$1795

EGA COLOR SYSTEM

- W/EGA Card & Monitor
- 20 MB Hard Disk

\$1580



PCI-386-16

- W/40 MB HD

\$2395

PCI-386-20

\$2695

GAS PLASMA 286-12 ___ \$2295

- 80286-12 CPU
- SI = 13.3
- 3 1/2" FD 1.44 MB
- 20 MB HD ST-138
- LCD Screen (640 X 400)
- I/O Card Parallel/Serial/Game
- 640K RAM



GAS PLASMA 286-16 ___ \$2495

- CPU 80286-16
- SI = 18

LCD-286-10 PORTABLE ___ \$1595.00

- 10 MHz 80286 SI=10.3
- 12 MHz SI = 13.3 (Option \$50.00)
- 16 MHz SI = 18 (Option \$250.00)
- 640K RAM
- LCD Screen 640 X 200 (Option 640 X 400 \$180.00)
- Super Twist & Back Lighting
- 86 Key Board
- External / Parallel / Game
- 1.2 MB Floppy drive
- 20 MB Hard Disk
- 80287 Socket
- 200 W Power Supply
- Side 15 3/4" X 9 1/2" X 8"
- 23 LBS

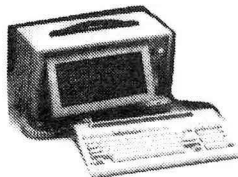

LCD-386-16 ___ \$2795.00

- 80386-16 MHZ
- 40 MB Hard Disk
- 80387 Socket

LCD-386-20 ___ \$3095.00

- 80386-20 MHZ
- 40 MB Hard Disk
- 80387 Socket

CRT-PORTABLE-286 ___ \$1389

- Compaq Type
- 80286 (10 MHz or 12 MHz)
- 12 MHz SI = 13.3 (Option \$50.)
- 16 MHz SI = 18 (Option \$250)
- One 1.2 MB Floppy Drive
- 200 W Power Supply
- TTL Disply 9" Amber
- AT Key Board
- Serial / Parallel / Game
- WA2 HD & FD Controller
- 20 MB Hard Disk

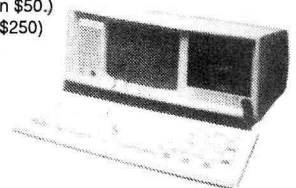

CRT-386-16 \$2595

CRT-386-20 \$2895

• 80386-16

PCI PACIFIC COMPUTER

702 S. Del Mar Ave., #B,
 San Gabriel, California 91776
 (FAX) 818-286-8662

(818) 571-5548 (Technical support)

(800) 421-1102 (IN CA) ORDER ONLY

(800) 346-7207 (OUT CA)

*ALL SYSTEMS COME WITH ONE YEAR PARTS & LABOR WARRANTY

Mon - Sat
 9:00 AM - 6:00 PM



This could be the most productive phone number you call today. Toll free. 1(800)531-5369

(Or, if you prefer to FAX your order—1 (512) 344-2985.)

TrippLite® Battery Back-Ups

Protect your equipment and data by providing safe shut down time for your computer systems and other sensitive equipment during black or brown-outs. Data loss from one black-out can cost you hundreds, if not thousands of dollars.

These units feature AC line spike and noise suppressors, status indicator lights and heavy gel-cell batteries—a regulated battery charger automatically restores battery to full charge when AC power returns.

\$1299.00

\$799.00

\$399.00

\$599.00

\$299.00

\$239.00

BC-200 200-W BC-325 325-W BC-750 750-W SC-BC-2000 2000-W BC-1200 1200-W BC-450 450-W

This complete TrippLite® Series offers reliable battery back-up at an extremely low price.

TrippLite® Voltage Regulator—Line Conditioners

\$79.00 **\$149.00** **\$199.00**

LS-600 LC-1200 LC-1800

TrippLite® Line Stabilizer/Conditioners automatically adjust varying input voltage to provide full voltage support during a low voltage condition while suppressing spikes and line noise.

Hard Drive Cases

SDH-2H **\$99.00**

This sturdy metal cabinet is capable of handling up to two 1/2 height hard disk drives—comes complete with fan, switching power supply and mounting hardware. (Drive cables not included) 14 7/8" W X 13 7/8" D X 2 5/8" H.

Switchboxes

These sturdy metal switchboxes allow you to share computers, printers and other peripherals quickly and easily. They have gold-plated contacts and are EMI/RFI protected.

DB-25 25 Line Switchboxes

Stock #	Description	Price
AB25-2	Two position	\$19.95
AB25-3	Three position	25.95
AB25-4	Four position	28.95
AB25-5	Five position	38.95
AB25-6	Six position	59.95
AB25-X	Cross over	29.95

Centronics 36 Line Switchboxes

Stock #	Description	Price
AB36-2	Two position	\$23.95
AB36-3	Three position	29.95
AB36-4	Four position	34.95
AB36-5	Five position	44.95
AB36-X	Cross over	37.95

We carry a complete line of switchboxes for your different requirements. Call for more information!

Cable Assemblies

PC/AT Parallel Printer Cables

Stock #	Length	Price
PPC301-6	6 ft.	\$ 6.95
PPC301-10	10 ft.	7.95
PPC301-15	15 ft.	11.95
PPC301-25	25 ft.	17.95
PPC301-6RA	6 ft.	12.95

DB-25 - 25 Line Cables Male-Male

Stock #	Length	Price
25MM-6	6 ft.	\$ 6.95
25MM-10	10 ft.	7.95
25MM-25	25 ft.	17.95
25MM-50	50 ft.	33.95
25MM-100	100 ft.	62.95

POPULAR CABLES

Stock#	Description	Price
MEC-6	Monitor Ext.	\$5.95
KEC-6	Keyboard Ext.	3.95
ACPC-03	Power Adapter	4.95
ATM-6	AT Modem Cable	5.95

call Other cables available

DB-25 - 25 Line Cables Male-Female

Stock #	Length	Price
25MF-6	6 ft.	\$ 6.95
25MF-10	10 ft.	7.95
25MF-25	25 ft.	17.95
25MF-50	50 ft.	33.95
25MF-100	100 ft.	62.95

Altex Electronics, Inc.

"Your Electronics Supply House"

TERMS: Minimum order \$10.00. We accept Mastercard, Visa, and American Express at no additional charge. For C.O.D. orders, add \$2.20. For orders under \$100.00, add \$3.00 handling and actual UPS shipping charges. For orders over \$100.00, we pay handling charge—you pay actual UPS shipping charges plus insurance. Purchase orders accepted from approved accounts. All returns require an RMA# and are subject to a restocking fee. Texas residents add 7.5% sales tax. Prices subject to change and we are not responsible for typographical errors.

Store Hours: 8:00-6:00 M-F, 10:00-2:00 SAT CST
10731 Gulfdale, San Antonio, Texas 78216

OMNI Power Director

CC16-P **\$79.95**

TrippLites' ISOBAR command console provides the highest level of surge and noise suppression of any console unit on the market today. Features include 6 outlets, 5 lighted power switches, protection indicator light, 15 amp circuit breaker and 12-foot power cord.

Eprom Programmer

\$179.95

EW-904

You can program your own EPROMS with this EPROM programmer—it can program up to 4, 16K thru 512K EPROMS simultaneously—easy to use software is included.

Eprom Eraser

\$79.95

LA-6T

You can erase your EPROMS quickly and easily at home or workplace with this easy to use EPROM eraser with built-in timer. It features an adjustable exposure time with alarm and is static protected. Without timer (not shown). LA-6A

\$59.95

DYNAMIC RAMS

SIMM	80/100	\$CALL
1MBIT	100ns	\$33.00
514256	100ns	\$37.00
41464	150ns	\$14.50
41256	120ns	\$11.95
✓ 41256	150ns	\$10.15
✓ 51258	100ns	\$12.25
✓ 4164	150ns	\$ 2.85

* For high-speed, Zip, Ploc, Simm Please Call!

PROCESSORS		E PROMS	
80387-20	20MHz \$465.00	27C101	250ns \$23.00
80387-16	16MHz \$390.00	27C512	200ns \$15.00
80287-10	10MHz \$252.00	27212	250ns \$ 9.50
80287-8	8MHz \$218.00	27C256	250ns \$ 5.50
8087-1	10MHz \$184.00	27256	250ns \$ 4.95
8087-2	8MHz \$142.00	27128A	250ns \$ 5.25
8087	5MHz \$ 97.00	27C64A	200ns \$ 4.95
V-30	8MHz \$ 12.75	2784	250ns \$ 3.50
V-20	10MHz \$ 17.00		
V-20	8MHz \$ 8.50		

I.C. EXPRESS

15358 Valley Blvd. City of Industry, CA 91746 Tel: 818-369-2688
ORDER TOLL FREE (Mon-Fri 8-5 PST)
(800) 892-8889 • (800) 882-8181

CALL FOR CURRENT PRICES & VOLUME DISCOUNTS
Price shown for cash. MasterCard/Visa add 3%. Prices are subject to change. Minimum order \$10.00. Shipping & Handling: UPS Ground \$5.00, Air \$7.00 (1 lb.). ALL MERCHANDISE IS 100% GUARANTEED WITH PROMPT DELIVERY.

FREE CATALOG

RS-232C INTERFACE & MONITORING EQUIPMENT CATALOG



WRITE OR CALL for YOUR FREE COMPREHENSIVE B & B ELECTRONICS CATALOG TODAY! Pages and pages of photographs and illustrated, descriptive text for B&B's complete line of RS-232C converters, RS-422 converters, current loop converters, adapters, break-out boxes, data switches, data splitters, short haul modems, surge protectors, and much, much more. Most products meet FCC Part 15J. Your RS-232 needs for quality, service and competitive prices will be more than met by B&B ELECTRONICS. Manufacturer to you, no middleman! Money-back guarantee! Same-day shipment! One-year warranty on products! Technical support is available.

Order direct from manufacturer TODAY & SAVE!

Write For Your FREE Catalog Today!

B & B electronics

MANUFACTURING COMPANY
4002B Baker Road, P.O. Box 1040 • Ottawa, IL 61350
Phone: 815-434-0846

Circle 106 on Reader Service Card

Circle 28 on Reader Service Card



GANG/SET (E)EPROM MULTIPROGRAMMERS™

Model 135-E: \$995.00
Others from \$345*

- Model 135 is a SET Programmer, GANG Duplicator, & UNIVERSAL Device Programmer.
- Programs virtually all 24, 28, & 32-pin (E)PROMs.
- RAM expandable to 2 MegaByte.
- Optional support for 40-pin EPROMs, Bipolar PROMs, 40-pin Micros, & (E)PLD/GAL/FPLA's.
- DATA I/O* protocol compatibility.
- 18-Month WARRANTY & 12-Month FREE Device Updates.

1-800-523-1565

In Florida: 1-407-994-3520

BYTEK * BYTEK Corporation
508 NW 77 Street, Boca Raton, FL 33487
FAX: (407) 994-3615 Telex: 4998369 BYTEK

* U.S. Prices only * DATA I/O is a registered trademark of DATA I/O

Circle 43 on Reader Service Card



! not only a printer buffer !

THIS IS THE MOST SOPHISTICATED PRINTER BUFFER - MULTIPLEXOR - SWITCH

WITH TWO SEPARATE INPUTS (SERIAL AND PARALLEL) AND TWO SEPARATE OUTPUTS (SERIAL AND PARALLEL) CAN BE USED LIKE STANDARD BUFFER. WITH ANY INPUT TO ANY OUTPUT... BUT ALSO YOU CAN CONNECT 2 COMPUTERS TO 1 PRINTER OR 1 COMPUTER TO 2 PRINTERS, OR 2 COMPUTERS AND 2 PRINTERS, AND MORE = 1 COMPUTER TO 3 PRINTERS OR 3 COMPUTERS TO 1 PRINTER

HIGH CAPACITY - 64 KB to 256 KB AND - 256 KB to 1 MB (MODELS A AND B) PAUSE, COPY and RESET FUNCTIONS SERIAL PORTS WITH 7 OR 8 BITS WORD LENGTH, 1 OR 2 STOP BIT, PARITY, XON/XOFF, DTR, RTS

DOB-A-64K \$ 195 DOB-B-256K \$ 255 (**)

(**) Power supply and parallel cables are included

ALSO, WE HAVE THE MOST COMPLETE DATA CONVERTER UNIT CONVERTS RS232 SERIAL TO CENTRONICS PARALLEL OR VICE VERSA, JUST BY MOVING JUMPERS BAUD RATE AND PROTOCOL FULLY PROGRAMABLE FROM 160 TO 19200 BAUDS INCLUDES: DTR, RTS, XON/XOFF, PARITY, etc

DCU \$ 80 (**)

(**) Power supply and cables NOT included

serial \leftrightarrow parallel bi-directional converter

INTECTRA Inc. - Dept. 292
2629 TERMINAL BLVD MOUNTAIN VIEW - CA - 94043
(415) 967-8818 TX 345545



AMX 68000

KADAK's engineers bring years of practical real-time experience to over 600 installations world-wide.

This real time MULTITASKING KERNEL simplifies real life product development

- No royalties
- Full source code included
- C interface
- Preemptive scheduler
- Intertask messages
- Terminal Handler
- Dynamic memory allocation
- Event Manager
- Semaphore Manager
- Resource Manager
- Buffer Manager

AMX 68000 operates on any 68000/10/20 system

Manual only \$75 US
AMX 68000 \$1600 US
* Options - ask for price list.
(Shipping/handling extra)

Also available for 8086, 286, 8086/186/286

KADAK Products Ltd.
206 - 1847 W. Broadway
Vancouver, B.C. Canada V6J 1Y5
Telex: 04-55670
Fax: (604) 734-8114
Telephone: (604) 734-2796

Circle 120 on Reader Service Card



9 TRACK TAPE SYSTEM

FOR IBM PC/XT/AT

- Mainframe to PC Data Transfer
- High Speed Backup
- All Software, Complete System
- Service and Support, easy Installation

call (818) 343-6505 or write to:
CONTECH Computer Corp.
P.O. Box 153 Tarzana, Calif. 91356

CONTECH

Circle 65 on Reader Service Card

SONY

	2-4 box	5-9 box	10+ box
3 1/2 DS	15 ⁹⁵	15 ⁸⁰	15 ⁵⁵
2 meg HD	37 ⁹⁵	37 ⁵⁰	36 ⁹⁵

3 1/2" SINGLE	MAC-PAC-50 (50)	(100)	"NO LABEL" (400)
DOUBLE	1.15 ^{ea}	1.12 ^{ea}	1.09 ^{ea}
	1.27 ^{ea}	1.22 ^{ea}	1.19 ^{ea}

Old Reliable
Delaware 1-800-451-1849
P.O. BOX 10247, WILMINGTON, DE 19850
Oklahoma 1-800-654-4058
P.O. BOX 1674, BETHANY, OK 73008
Nevada 1-800-621-6221
P.O. BOX 12396, LAS VEGAS, NV 89112
TELEX-4933362 FAX 405-495-4598



BASF

5 1/4" DOUBLE SIDE HIGH DENSITY	PACKAGED 10 PER BOX		
	2 Boxes	5 Boxes	10 Boxes
	6 ⁶⁰	6 ⁴⁰	6 ²⁰
	9 ⁸⁰	9 ⁶⁰	9 ³⁵

MF-1D	11 ⁶⁰	11 ³⁵	11 ²⁰
MF-2D	14 ²⁰	13 ⁹⁵	13 ⁸⁰
MF-2HD	36 ³⁵	35 ⁷⁵	35 ⁴⁵

Old Reliable
Delaware 1-800-451-1849
P.O. BOX 10247, WILMINGTON, DE 19850
Oklahoma 1-800-654-4058
P.O. BOX 1674, BETHANY, OK 73008
Nevada 1-800-621-6221
P.O. BOX 12396, LAS VEGAS, NV 89112
TELEX #4933362 FAX #405-495-4598



maxell®

OPTICAL DISKS CALL

Packed 10/Box	2 Box	5 Box	10 Box
5 1/4" * MD-2D	6 ⁸⁵	6 ⁷⁰	6 ⁵⁵
MD-2HD	12 ⁵⁰	12 ²⁵	11 ⁹⁵
3 1/2" * MF 1DD	~ 12 ⁶⁵	12 ⁴⁵	12 ²⁵
MF 2DD	~ 15 ⁶⁰	15 ⁴⁰	15 ²⁵
MF 2HD	~ 37 ⁰⁰	36 ⁵⁰	35 ⁹⁵
8" * FD 1-1200	~ 19 ⁹⁵	19 ²⁰	18 ⁴⁵
FD 2-1200	~ 23 ⁶⁵	22 ⁷⁵	21 ⁸⁰

Old Reliable
Delaware 1-800-451-1849
P.O. BOX 10247, WILMINGTON, DE 19850
Oklahoma 1-800-654-4058
P.O. BOX 1674, BETHANY, OK 73008
Nevada 1-800-621-6221
P.O. BOX 12396, LAS VEGAS, NV 89112
TELEX #4933362 FAX #405-495-4598

Minimum order \$20.00 * No Surcharge on Visa MasterCard * COD orders add \$3.00 Surface, Shipping UPS add \$3.00 per 100 for 3 1/2" or 5 1/4", add \$4.00 per 100 for 8" U.S. Mail delivery add 9% * Prices subject to change without Notice.

LA COMPUTER CORPORATION

A California Corporation

213-328-9294
INSIDE CALIFORNIA

800-888-9294
OUTSIDE CALIFORNIA

213-328-1758
FAX

LACC	COMMITMENT TO EXCELLENCE	LACC
THE VECTOR XT TURBO 4.77 to 10 MHz • 256 to 640k 150 Power Supply • AT Style Keyboard 1 Drive with cont. • AT Case Turbo Switch \$429 with Monochrome with color \$589 \$769	THE VECTOR (286-10) 80286 • 640k • Up to 1 Meg • 1.2 Meg Floppy AT KB • Floppy and Hard Controller 200 Watt Power Supply \$899 with 30 Meg. with 30 Meg. with Monochrome with color \$1395 \$1609	THE VECTOR (386) 6/16 MHz INTEL 80386 • 1Mb RAM Expand to 4Mb RAM • 1.2 Meg. Floppy Par., Ser., Clock, Calendar 200 Watt Power Supply • AT Keyboard \$2289 with 40 Meg. with 40 Meg. with Monochrome with Color \$2699 \$2899

BLOW OUT SPECIALS

NEC EFL360 Letter Quality Printer 22 CPS Daisywheel Demo unit • Original Box 90 Day Warranty RETAIL \$545 ONLY \$149	XT Compatible Case <i>While they last</i> \$24	NEC Multisync 11-569 Monitor LACC - MonoCard w/par \$49 LACC - 1200B InternalMon. with Software \$56 Zenith 1490 Fiat \$569
AST PREMIUM/286 PC MAGAZINE ED'S CHOICE Model 80 Call Model 140 \$2359 Model 120 2099 Model 170 2699	COMPAQ Desk Pro 286 • 12 MHz • 40 Meg. . . \$2395 Portable II Model 2/4 1995/2599 Portable 386 • 40 Meg. 5599	IBM <i>Prices to Low to List</i> Model 30 Call Model 50 • 20 Meg. w/monitor . . . \$2875 Model 60 • 44 Meg. w/monitor . . . \$3495 Model 80 • 44 Meg. Call

ALL SYSTEMS COME WITH A ONE YEAR WARRANTY
AND OUR 15 DAY MONEY BACK EXCHANGE POLICY

HARDWARE SPECIALS

Segate ST4096 80MB	\$589
Segate ST238 30mb w/Controller	250
Segate ST 225 with Controller (20 Meg. Hard Disk)	239
Panasonic 1091i (Model 2)	169
Samsung EGA	349
INTEL Inboard 386	Call
Hayes 1200 B with Software	259
Amdek Monitor 410 Amber or White	\$145
ATASI 40 Meg.	319
NEC Multisync	549
Arcive 5540 Tape Drive	Call
HP Lazer Jet II	599

SOFTWARE SPECIALS

Lotus 1,2,3	\$309	Norton Utilities	\$ 48
Micro Soft Word	199	Micro Soft Flight Simulator	29
Word Perfect	195	D Base 3 Plus	375
Word Star Pro Rel.	219	Crosstalk MK4	109
Print Shop	33	Fast Back	89

**WE WILL MATCH OR BEAT
ANY ADVERTISED PRICE**

HERE ARE SOME OF THE LOW PRICES YOU'LL FIND AT OUR STORE

MODEMS	PRINTERS	MEMORY CHIPS/MEMORY BOARDS
EVEREX 1200i (W) S.W. \$ 77	PANASONIC 1080i (140 CPS 80 Col) \$159	INTEL 8087-2 \$144
2400i (W) S.W. 169	1092i (240 CPS 80 Col) 269	8087-3 101
HAYES 1200 EX 279	1524 (24 Pin 132 Col) Call	80287-6 175
1200 B Intorc 269	1592 (132 Col 180 CPS) 399	80287-8 244
2400 EX 399	3131 Letter Quality Call	80287-10 299
2400i 409	LQ-500(180 CPS) 60 CPS NLQ	80387 (16 MHz) 469
Incomm — 2400 Ext Call	LQ-850(264 CPS d.m)—	Above board—286A + 512 389
US ROBOTICS 2400i \$229	LQ-1050 —	PC64K 209
1200i 99	LQ-950 (264 cps d.m)—	PS(PC) Multifunction 229
VOLKSMODEM 1200i \$119	LQ-2550—(324 cps)—	Six Pac Plus with 64K 109
1200X 119	FX800 - (300 cps) 54 cpsln (NLQ)	Multi Board Exp. to 2 Meg. 119
	FX286e-(240 cps) 48 cps (INLQ)	64K (9 Chips) 150 NS Call
	FX-850 (264 cps)	256K (9 Chips) 150 NS Call
	FX1050	
	LX800 - \$199	
FLOPPY DRIVES	MONITORS	HARD DRIVES
TEAC 55B½ Ht. 360 DS/DD \$79	SAMSUNG TTL 1252 Flat Screen Mono. 75	SEGATES 20 MB ½ HD (ST225) \$265
1.2 Meg. ½ Ht. 99	LACC Monochrome 69	30 MB ½ H (ST238) 299
¾ Ht. for IBM 99	310A 139	40 MB (ST251) 419
REMAX TANDON 100-2 DS/DD 69	1280 (Desk Top) 729	30 Meg. ATSA1 329
CHINON 720K 3½ PC 69	EGA Multiscan CPD 1302 Call	70 Meg. Miniscrbe Call
IBM ¾ Ht. 69	(Requires EGA or Compact Card)	
	PAKARD BELL TTL Monochrome 69	
GRAPHIC BOARDS	COMPUTERS	FAXES
HERCULES Monographics Card \$169	Apple Products Available	Brother FAX 100 Call
Colorgraphics Card 179	Macintosh — Image Writers	Brother FAX 150 999
HERCULES Monochrome w/S.W. Par. Port. 59	Plus More! — Call for current prices!	Sharp- FO 300 FAX 1209
COMPATIBLE Color Par. Port 59		Sharp- FO 420 FAX 1329
EVEREX EGA 000		
OKIDATA		
182 Plus 229		
232/233/234 Plus Call		
ML 320/390/393 Call		

WE WILL NOT
BE UNDERSOLD ON
THESE PRICES

Too Many items to list.
Please call for information.

LOW-LOW-LOW

hp Laserjet Printer Series II **\$1650**
hp Scanjet Scanner + interface kit **\$1355**

IBM COMPAG Apple ACER
EVEREX AST & other

XT/AT Compatibles & 386 Computers
CALL for LOW PRICES

Gov't, Corporate, Schools, Dealers,
 & Export **INQUIRIES WELCOME.**

SURAH inc.

44862 Osgood Road, FREMONT, CA 94539
 PH: (415) 651-5101 FAX: (415) 651-5241
 1-800-543-1001
 VISA, Master Card accepted. w/sc

Circle 224 on Reader Service Card



System 1800 Basic System \$899 (MADE IN U.S.A. with quality)

- Intel 80286 CPU
- Fully compatible with IBM AT
- 6.8 MHz selectable, 8 slots
- 512K on 1M mother board
- 195 watt power supply 110/220
- Clock/Calen. Everex HD/CD rom.
- FCC class "B" approved
- 48 Hour factory high temp dynamic burn-in
- 1.2 MEG Teac Dr. AT Keyboard
- Runs Altobaud, Lotus, Xenix, Novell, all prog. Software
- 200 pages of documentation (written in U.S.A.)
- 80287 C/D Processor socket
- 80000 units installed with customer report on file
- Made in U.S.A. with 1 year warranty

Special \$995
 Mono Sys (Basic Sys. + Evergraphics 132 col. wpp. 14" Everex Flat Mon.)
 EGA Sys (Basic Sys. + Everex EGA card + 14" Everex EGA (31mm) Mon.) \$1414
 Super EGA Sys. (Basic Sys. + Everex EGA card + NEC 10/10mm 8060 (31mm) Mon.) \$1700
 System 1800 12MHz 386 0 wait 512K, 25. IP, KB, Base system. \$1099
 System 1700 12MHz 386 0 wait 1 meg RAM, KB, Base system. \$1395
 System 3000 16MHz 386 0 wait 1 meg KB, Base system. \$1895
 System 3000 20MHz 386 0 wait 1 meg KB, Base system. \$2300

Full Line of Everex Products Available

PEC 286 16/12/10	System 1800XT 10 MHz, 256K	\$535
Model PEC 286/10MHz, 512K	System 1800XT 12MHz, 256K	\$635
Model PEC 286/12MHz, 512K	Novel Parallel VGA Plus 16 bit	\$329
Model PEC 286/16 MHz, 512K	VGA Monitor (Special)	\$445

Schwab Computer Center
 "The Everex Store" - Authorized Everex Corp. VAR
 3282 El Camino Real, Santa Clara, CA 95051
 408-241-1210 Fax # 408-241-1279
 Daily UPS M-F 10-7, SAT 11-4 VISA/MC/AE
 Prices change without notice

Circle 205 on Reader Service Card

REAL WORLD I/O

For PC/XT/ATs

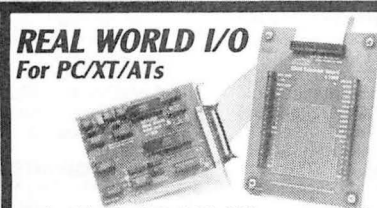

DG24 • 24 line digital I/O; 10 MHz 8255. **\$95**
AD500 • 8 channel 12-bit (plus sign) integrating A/D; prog. gains of 1, 10 & 100; 7 digital I/O lines. **\$239**
AD100 • Single channel version of AD500; 10 digital I/O lines. Same programmable gains. 700 meg input Z. **\$149**
AD1000 • 8 channel 12-bit A/D; 25 uS; sample & hold; 3.5 MHz timer/counters; 24 digital I/O lines. **\$295**
ADA300 • 8 channel 8-bit 25 uS A/D; single D/A sample & hold; 24 digital I/O lines. **\$239**
AD200 • 4 channel 12-bit 125 uS A/D; 3.5 MHz timer/counters; 24 digital I/O lines. **\$239**
DA600 • Fast settling dual bipolar D/A. **\$179**
PD200 • Prototype board w/ address decoder, manual **\$99**

All boards include BASIC, Pascal, C, and Fortb drivers.
 30 day return; 1 year warranty. Call for "Real World Interfacing" application notes.

Real Time Devices, Inc.
 P.O. Box 906 State College, PA 16804
(814) 234-8087

Circle 198 on Reader Service Card

6809

Single Board Computer

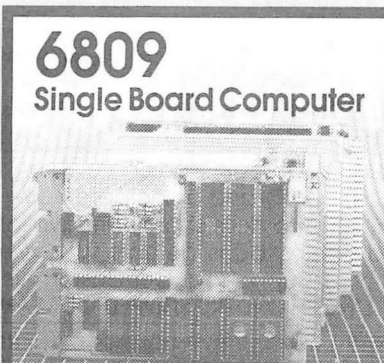

6809 MPU, 2 serial ports, 4 parallel ports, RAM, EPROM, real-time clock, watchdog timer, 44-pin 4.5" x 6.5" PCB

EXPANSION MODULES: RAM, EPROM, CMOS RAM/battery, analog I/O, serial I/O, parallel I/O, counter/timer, IEEE-488, EPROM programmer, floppy disks, cassette, breadboard, keyboard/display.

WINTEK Wintek Corp.
 1801 South Street
 Lafayette, IN 47904
 317-742-8428

Circle 250 on Reader Service Card

NEW!

INSTANT TERMINAL

"EXACT TERMINAL EMULATION AND COMMUNICATIONS SOFTWARE"

- PRECISE EMULATION OF THE DEC VT52, VT100, VT102, VT220
- EXPANSION MODULES FOR OVER 40 EXACT EMULATIONS
- 9 FILE TRANSFER PROTOCOLS.
- EASY TO USE, QUICK TO INSTALL, AND MUCH MORE
- IBM PC, XT, AT, PS/2

FOR INFORMATION
800/548-9777

ONLY \$97.50

SOFTRONICS
 303/593-9540
 TELEX 450236

Circle 212 on Reader Service Card

MasterCard **SABINA** VISA

SAME DAY SHIPMENT

D - RAMS

41256 - 06	\$12.30
41256 - 10	\$11.00
41256 - 12	\$10.80
41256 - 15	\$9.80
1mg x 1 - 10	\$35.00
1mg x 1 - 08	\$40.00

MATH CO - PROCESSORS

8087	\$98.00
8087 - 02	\$140.00
80287 - 08	\$220.00
80287 - 10	\$270.00
80387 - 16	\$360.00
80387 - 20	\$510.00
80387 - 25	\$620.00

CALL FOR LOWEST PRICES
1-800-2-SABINA

SABINA INETRATIONAL, INC.
 657 Brea Canyon Road Suite #4
 Walnut, California 91789
 (714)594-6336 • FAX (714)595-4008
 PRICES SUBJECT TO CHANGE WITHOUT NOTICE

Circle 201 on Reader Service Card



E(E)PROM, MICRO & MEMORY CARD PROGRAMMER.... \$345 - \$595

- No personality modules for E(E)Proms & Intel Micros.
- All 24/28/32 pin EProms to 1 MBit (upgradeable to 32MB)
- 8741, -2, -4, -8, -8H, -9, -9H, -51, -52, -55, 9761. EEPROMS.
- Memory Cards: Seiko/Epson, GI. Flash Eproms. On-board Programming capability. Easy F/W upgrades. Modular design.
- Stand-alone E(E)Prom & Memory Card Duplication / Verify.
- User friendly menu - driven driver for IBM-PC & Macintosh.
- Autobaud RS232 to any computer. Hex/Binary/Intel/Motorola.
- Built-in Eraser/Timer option (\$50). Gang-Module ready.
- Direct technical support. Full 1 year warranty.

Call today for datasheets!

B&C MICROSYSTEMS INC.
 355 West Olive Ave, Sunnyvale, CA 94086
 (408)730-5511 FAX: (408)730-2155 TLX: 984185

LOW COST INTERFACE CARDS FOR PC/XT/AT



PC485D \$95

[RS 485/422 INTERFACE]

- Meets the EIA RS-485 standard for multipoint bus transmission and the EIA RS-422A standard.
- Can be configured as COM1 or COM2.
- Line terminators are jumper selectable.
- High speed differential drivers allow fast data transfer over long cables (over 4,000 ft). Max. Baud rate 56KB/115KB.
- Tri-state line drivers permit implementation of LANs.
- Two wire (half duplex) operation. DB9 or phonejack.
- Sample communication software available. (\$50)

PC488A \$145

[IEEE - 488 INTERFACE]

- Includes INSTALLABLE DOS DEVICE DRIVERS and software support for BASIC.
- Optional language support for C, PASCAL, FORTRAN and ASSEMBLY - \$50
- Selectable base I/O address, IRQ and DMA.
- CONTROLLER / TALKER / LISTENER capability.
- Customer support via dedicated 24 hours B&C Microsystems BULLETIN BOARD.
- Compatible with most IEEE-488 Software Packages for the IBM-PC (e.g. ASYSTANT GPIB, Lotus Measure, etc.).
- Hardware compatible with N.I. GPIB - PCIIA.

PC488B \$345

[IEEE - 488 CARD WITH]
 [BUILT-IN BUS ANALYZER]

- GPBASIC package complements IBM/Microsoft BASIC interpreter and compiler to create a programming environment similar to HP desktop computers.
- Additional libraries of over 20 high level 488 dedicated functions for C, Pascal or Fortran available (\$50 ea.).
- Powerful menu-driven bus analyzer, which can run in the foreground or in the background while 488 programs or commands are executed, features program stepping, break points and real time bus data capture (4k circular buffer).
- Instant toggling between foreground and Analyzer screen.
- Dipswitch selectable Base Address, IRQ, DMA.
- Talker/Listener/Controller capability. Based on TMS-991.
- NEC-7210 based version (NI PCII/IIA compatible) - \$ 445

MC/VISA/AMEX Call today for datasheets!

B&C MICROSYSTEMS INC.
 355 West Olive Ave, Sunnyvale, CA 94086
 (408)730-5511 FAX: (408)730-2155 TLX: 984185

Circle 30 on Reader Service Card

PC Software as low as \$249

Thousands of IBM/Compatible Public Domain and Shareware Programs Are Available from the Micro Star Library and at Incredibly Low Prices!



We feature the best and most up-to-date shareware available.

Our software is guaranteed against bugs, defects, viruses, etc.

And We Offer FREE Technical Support For Our Customers

ORDER TODAY on our TOLL FREE PHONE LINES • ORDERS SHIPPED OUT SAME OR NEXT DAY



GAMES

ARCADE GAMES (106) Has Kong, 3-D Pacman, Bricks, Pango. (Requires color.)

BASIC GAMES (107) Pacman, Lunar Lander, Startrek, Meteor, Breakout, and others.

CARD GAMES (109) Canasta, hearts, draw poker & bridge.

STRIKER (110) Defender-like game. "Top Gun" in space.

FLIGHTMARE (112) Futuristic fighter pilot game. (Requires color graphics adapter.)

SLEUTH (117) Who done it? **DND (119)** Like Dungeon and Dragons.

ROUND 42 (120) Better than Space Invaders. 42 levels.

GAMES IN BASIC (124) Lander, biorhythms, desert, Phoenix, Star Wars, others.

QUEST (152) Role playing adventure fantasy game. (Requires CGA.)

SPACE WAR (158) Dogfight in outer space, using phasers, photon torpedoes, etc.

BRIDGE PAL (171) Complete game of contract bridge, with tutorial.

FENIX (193) Just like the famous arcade game.

PINBALL GAMES (197) Pinball, Rain, Twilight Zone, Wizard, etc.

KID-GAMES (GAM8) Animals math, clock game, alphabet, etc.

CHESS (GAM9) Incredible. 2D and 3D. Many levels. Play back moves, store games.



EGA RISK (GAM11) World domination in great color. Includes EGA Asteroids.

PC PRO-GOLF (GAM27-28) Great graphics. Complete 18 hole, 72 par course. (CGA)

PEARL HARBOR (GAM32) Shoot down Jap Zeros before they destroy U.S. Fleet. (CGA)

ULTIMA 21 DELUXE (GAM34) Best Blackjack game around. Includes Video Poker.

FORD SIMULATOR (GAM37) Great driving simulation. (CGA)



MUSIC

PIANOMAN 4.0 (301) Turn your keyboard into a piano.

PC-MUSICIAN (302) Compose, save, and play music.

WORD PROCESSING

PC-WRITE 3.0 (434, 435, 436) (3 disks) Newest version! Very popular and complete. Includes spelling checker.

PC-TYPE+ (421-423) (3 disks) Excellent. Includes mail merge, 100,000 word spelling checker. Interfaces with PC-File+, PC-Style.

GRAPHICS

KEYDRAW CAD SYSTEM (1001, 1002, 1065) (3 disks) Popular. Also uses mouse. (Requires color graphics - CGA.)



SIDEWAYS (1007) Prints text sideways. Useful for spreadsheets.

SIMCGA/HGCIBM (1027, 1062) (2 disks) Use with Hercules graphics card/compatibles to run programs requiring CGA on your monochrome PC.

IMAGE 3-D (1048) Create and edit 3-D objects. Move, scale, rotate and tip image.

FINGERPAINT (1050) Use keyboard or mouse to draw. Like MacPaint. (Requires CGA or EGA.)

DANCAD 3-D (1051, 1052) (2 disks) Create 3-D graphics. Rotate, magnify, etc. Runs on CGA, EGA, or Hercules.

Banck + C 3D

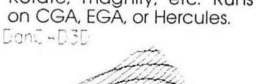

FANTASY (1057) Create flowing graphic images with mouse or keyboard. (CGA.)

FLOWCHARTING (1078-1079) Complete system for flowcharts, organizational, electrical, etc., with symbols.

RELIGION

THE BIBLE (3301-3306) (6 disks) Old Testament, King James version.

THE BIBLE (3307-3308) (2 disks) New Testament, King James version.

WORD WORKER (3309-3310) (2 disks) Bible search program. New Testament, King James version.

BIBLEMAN (3330) Excellent Bible quiz program.

BASIC

PC-PROFESSOR (1401) BASIC tutorial. Good.

BASIC PROGRAM GENERATOR (1402) The menu driven way to write programs.

B-WINDOW (1407) Give windowing capabilities to your Basic program.

UTILITIES

HOMEBASE (2608, 2612, 2613) Complete desktop organizer. Great!

PROFESSIONAL MASTERKEY (2805) Like Norton's. Retrieve deleted files. A lifesaver.

BAKER'S DOZEN (2821) 13 utilities from Buttonware.

AUTOMENU (3003) Make PC menu driven. Incl. passwords.

SCREEN (3006) Save your monitor from screen burn-in.

DOT MATRIX FONTS (3061-3062) (2 disks) Print your text in different fonts. Works with most printers.

ACCOUNTING/FINANCE

MARKET CGA (BUS17) Performs sophisticated analysis on stocks, funds, etc. (EGA version is BUS16).



BILLPOWER+ (BUS40) Bill clients for time and materials, advances, retainers, etc. Computes taxes, past due interest, etc. Has full G/L.

CPA LEDGER (706-708) (3 disks) Complete general ledger for corporations, partnerships or sole proprietors.

PERSONAL FINANCE MANAGER (715) Household budget manager. Keep track of checking, savings, investments.

PAYROLL USA (725-726) Up to 2,000 employees in any state. dBaseIII and Lotus compatible. Complete P/R system.

EXPRESS CHECK (786) Check account with running balance, monthly reports, etc. Prints checks.

FINANCE MANAGER II (774-775) (2 disks) For personal or small business financial management.

DOS

DOS TUTORIAL (1301) Teaches you to use DOS.

STILL RIVER SHELL (1304) Run DOS commands from a menu. Makes DOS easy.

BATCH FILE TUTORIAL (1305) Utilize batch file processing.

MORE DOS TIPS (1318, 1323) (2 disks) More about DOS.

HELP DOS (1326) On line DOS help with menus. Includes DOS dictionary of terms and a hints menu.

SPREADSHEETS

AS-EASY-AS (505) Great. Includes screen help menus. Utilizes function keys. A Lotus clone that reads Lotus files.

PC-CALC+ (512-514) (3 disks) Jim Button's famous Lotus clone.

EDUCATION

AMY'S FIRST PRIMER (248) Children's learning game that teaches letters, numbers and keyboard.

FUNNELS AND BUCKETS (201) A fun way to learn math.

MATHPAK (202) Tutorial with lessons in higher math.

PC-TOUCH (204) Learn typing.

BASIC TUTORIAL (208) Learn programming with BASIC.

BEGINNING SPANISH (211) Tutorial.

SPANISH II (232) Sequel.

BIBLEQ (214) Learn the Bible with this Q-A tutorial.

FACTS 50 (239) Geography lessons for U.S. Nice graphics.

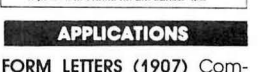

APPLICATIONS

FORM LETTERS (1907) Commonly used form letters and business applications.

EZ-FORMS (1908) Make forms to meet different needs.

MANAGER'S PLANNER (1920) Daily planner. Prints out.

HOME INVENTORY (1966) Track all your possessions.

BIORHYTHM (1990) Display the 3 biological cycles: physical, emotional, intellectual.

FAMILY HISTORY (2203-2204) (2 disks) Create files and genealogical reports.

DR DATA LABEL (2327) Powerful mailing list program. Customize labels to size.

Incredibly Low Prices

1-9 Disks \$299 ea.

10-19 Disks \$269 ea.

20 or more \$249 ea.

LOTTO PROPHECY (2364) Best Lotto program we've seen.

CITY DESK (2513) Simple desktop publisher.

SPREADSHEET TEMPLATES

LOTUS MACROS (601) Save hours of work. (Req. Lotus)

LOTUS SPREADSHEET TEMPLATES (602) Ready-made. (Requires Lotus 1-2-3)

GOAL-SEEKER V3.5 (624) Achieve objectives by changing spreadsheet and seeing result. (Requires Lotus.)

LOTUS TUTORIAL (630) Learn Lotus (requires Lotus).

ADULTS ONLY

ADULTS ONLY (2901) Animated. Req. CGA.

MAXINE (2902) Incredible. (CGA)

STRIP POKER (2903) Pick opponent (CGA)

BAD-BAD (2904) Adventure game.

ASTRO-BLEEP (2905) Arcade game (CGA)

X-RATED COLOR SHOW (2915) Beautiful girls. (CGA)

X-RATED PRINTSHOP (2909) Graphics for Printshop.

TELECOMMUNICATIONS

Q-MODEM 3.1 (1101, 1102, 1144) (3 disks) Powerful but easy to use. Fast.

RBBS V16.1A (1107-1109, 1150) (4 disks) Multi-user bulletin board system.

PROCOM 2.42 (1112-1113) (2 disks) Hacker's delight. Real. Tutorial capability. Latest version.

SECURITY/HACKING

COPY PROTECTION I (1219) Instructions for unprotecting commercial software.

COPY PROTECTION II (1220) More software unprotect.

COPY PROTECTION III (1221) Additional software to unprotect.

FLUSHOT (1225) Checks software for viruses.

DATABASE PROGRAMS

PC-FILE dB (801, 805, 837) (3 disks) Newest version! Rated better than dBase III+.

PC-GRAPH (802) Create graphics from PC FILE.

FILE EXPRESS 4.0 (803-804) Powerful system. Allows 32,000 records. Sorts up to 10 key fields.

DBASE III+ ROUTINES (851-852) (2 disks) Latest utilities to help you utilize dBase III+



MICRO STAR

1105 SECOND ST. • ENCINITAS, CA 92024

HOURS: Monday - Saturday 7 AM - 5:00 PM, Pacific Time

TERMS: We accept MasterCard, VISA, Checks (allow 10 days to clear), Money Orders, and COD (add \$4.00).

3 1/2" DISKS: 3 1/2" format add \$1/disk.

SHIPPING & HANDLING: \$3.50 (Total per order).

MAIL-IN ORDERS: Circle disk numbers. Include name & address.

CALL TODAY FOR FREE CATALOG

800-444-1343 Ext. 23
FOREIGN: 619-436-0130

9-TRACK TAPE SYSTEMS!



OVERLAND DATA IS THE EXPERT when it comes to connecting your PC to the mainframe and mini computer world.

- PC/XT/AT/386/PS2/compatibles
- 800, 1600, 3200, 6250 BPI
- Free tutorial on tape systems
- EBCDIC/ASCII conversion
- IBM & ANSI labeled tapes
- DOS, XENIX, UNIX, PICK
- Highest quality customer service
- Stock full range of tape drives
- Network backup and More!

Overland Data Inc.

5620 Kearny Mesa Rd. • San Diego, CA 92111
Tel: (619) 571-5555 • FAX: (619) 571-0982

Circle 172 on Reader Service Card

the HUSKY™

- EPROM
- PLD
- MICRO
- GANG
- SET

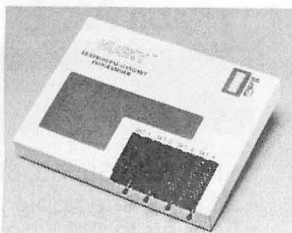

PC based PROGRAMMER
\$599.00*

*modules not included.

From A Name You Can Trust

LOGICAL DEVICES, INC.

1201 N.W. 65th Place, Ft. Lauderdale, FL 33309

1-800-331-7766 (305) 974-0967

Telex 383142 Fax (305) 974-8531

Circle 129 on Reader Service Card
(DEALERS: 130)

ICs PROMPT DELIVERY!!!

SAME DAY SHIPPING (USUALLY)

QUANTITY ONE PRICES SHOWN FOR DEC. 13, 1988

OUTSIDE OKLAHOMA: NO SALES TAX

DYNAMIC RAM			
SIMM	1Mx9	80 ns	\$450.00
SIMM	** 1Mx9	85 ns	390.00
SIMM	256Kx9	60 ns	150.00
1Mbit	1Mx1	100 ns	33.00
41256	256Kx1	60 ns	14.95
41256	256Kx1	100 ns	12.95
51258	*256Kx1	100 ns	13.50
41256	256Kx1	120 ns	12.25
41264	+ 64Kx4	120 ns	17.50
EPROM			
27C1000	128Kx8	200 ns	\$29.50
27C512	64Kx8	200 ns	13.95
27256	32Kx8	150 ns	8.15
27128	16Kx8	250 ns	4.95
STATIC RAM			
62256P-10	32Kx8	100 ns	\$22.95
6264P-12	8Kx8	120 ns	10.80

OPEN 6 1/2 DAYS, 7:30 AM-10 PM: SHIP VIA FED-EX ON SAT.

WE EXPORT ONLY TO CANADA, GUAM, PUERTO RICO & VIRGIN ISLANDS

SAT DELIVERY INCLUDED ON FED-EX ORDERS RECEIVED BY: The Std Air \$6.3/ lb. Fr: P-1 \$10.25/1 lb. MasterCard VISA or UPS CASH COD Factory New, Prime Parts µP, MICROPROCESSORS UNLIMITED, INC. 24,000 S. PONTIA AVE. (918) 267-4961 BEGGS, OK 74421 No minimum order. Please note that prices are subject to change. Shipping & insurance extra. & up to \$1 for packing materials. Orders received by 9 PM CST can usually be delivered the next morning, via Federal Express Standard Air @ \$6.00, or guaranteed next day Priority One @ \$10.25!

Circle 152 on Reader Service Card

All Items In Stock
100% Guaranteed
MC, VISA, COD Accepted
24 Hour Shipment
Call For Our Monthly Specials

BULK DISKS

3.5" DS/DD	
■ SONY	1.29
■ DATASAFE	1.09
■ TDK DS/HD	3.85
5.25" DS/HD	
■ TDK	1.29
■ DATASAFE	.89
5.25" DS/DD	
■ MAXELL	.64
■ VERBATIM	.59
■ 3M	.57
■ DATASAFE	.35

Prices based on 200 Disks
Includes Labels, Sleeves & Tabs
Smaller Quantities Available

In NJ **800-426-0247** FAX
201-892-5655 201-892-6186

PRINCETON
DISKETTE

432 Macarthur Dr. ■ Brick, NJ 08724

Circle 181 on Reader Service Card

PALMERASE™

World's Smallest UV Eraser

\$499⁹⁵



PALMERASE™ can erase 20, 24, 28, and 40pin EPROMs in less than 3 minutes! Also, larger erasers are available to handle EPLDs, MICROS and other UV erasable devices. Please call today for more information on an eraser that's right for you.

LOGICAL DEVICES, INC.

1201 N.W. 65th Place, Ft. Lauderdale, FL 33309
1-800-331-7766 • in Florida: (305) 974-0967

Circle 131 on Reader Service Card
(DEALERS: 132)

Satellite Communication MICROSAT II Expansion Board

\$700

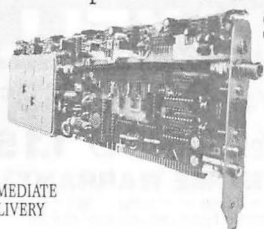

IMMEDIATE DELIVERY

- For IBM PC/XT/AT and compatible.
- Satellite data receiver - 9600 baud.
- Satellite bulletin board.
- Satellite video and audio option - Add \$200

PERSONAL SPACE COMMUNICATIONS

707 Johnson Road, Blaine WA 98230
(604)597-6298 TLX 04-508306 FAX (604)597-6214

Circle 179 on Reader Service Card

Emergency Power!

Even a "small" brownout can wipe your valuable data clean. Voltage spikes can burn out an entire CPU. Protect your equipment and data with a low-cost battery backup system.



Battery Back-up Power System — Spike and Surge Protection

450-watt, 120V power system for up to 2 hrs. (at 80 watt) continuous use during a complete black-out.

\$499⁹⁵

Model BC-450



Line Stabilizer — Voltage Regulation and Surge Suppression

1800 watt power output. Isobar® spike and noise protection.

\$299⁰⁰

Model LC-1800

TOLL FREE **800-648-2626**
(NY State 800-832-1446 Ext. 242)

SCOPE ELECTRONICS

260 Motor Pkwy, Hauppauge, NY 11788

ASK FOR FREE CATALOG Money orders, checks accepted. Please add \$15.00 per item shipping and handling. NYS residents add appropriate sales tax.

PROGRAMMERS

PUT ONE UNIT
ON YOUR DESK TODAY!

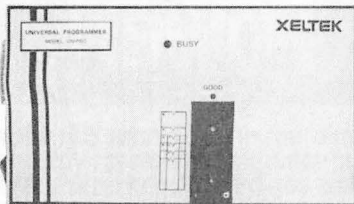

ULTIMATE PROGRAMMING & TESTING SOLUTION FOR EPROM, PAL, BIPOLAR, 8748 & 8751 SERIES, IC & MEMORY.

UNIPRO --- Only \$545 Complete
Optional 4-socket ADAPTOR for multiple EPROM programming --- \$99

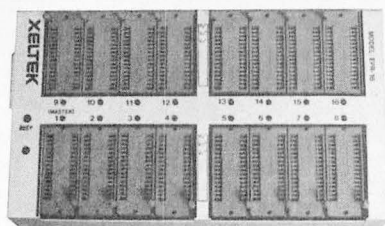

EPROM PROGRAMMERS --- FROM
(1,4,8,16 Socket gang programmers) **\$160**

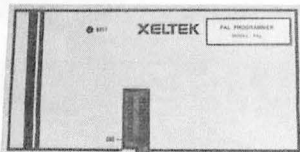

High-speed, dedicated PROGRAMMERS for PAL, BIPOLAR, 8748 Series, and 8751 Series, and IC & MEMORY TESTERS are also available.

Ask for PAL DESIGNING S/W
1. PALASM (MMI) 2. PLDesigner (MINC)
3. ORCAD PLD

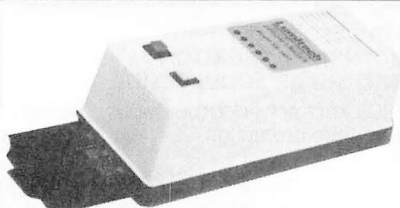

High Intensity EPROM ERASERS ---from \$59.90

OEM, DEALER INQUIRY WELCOME

XELTEK

473 SAPENA COURT, UNIT 24
SANTA CLARA, CA 95054

TEL. (408) 727-6995 FAX: (408) 727-6996

ORDER TOLL FREE

1-800-541-1975

VISA, MASTER, AMEX ACCEPTED

NEW

MULTI-CHANNEL PS/2



COMMUNICATION BOARD

- Four Independent RS-232 Ports
- Flexible Interrupt/Address Options
- Discounts Available
- For Models 50, 60, 80

1-800-553-1170



478 E. Exchange St., Akron, OH 44304
TEL: (216) 434-3154 FAX: (216) 434-1409
TLX: 5101012726

Circle 186 on Reader Service Card

RS-422 Communications Board

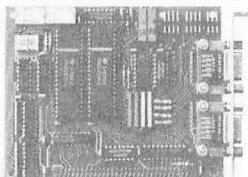

- For IBM PC/XT/AT/PS/2
- Dual channel RS-422/RS-485
- Selectable/shareable interrupts
- Differential drivers to 4000 ft.
- Immediate delivery

1-800-553-1170



Leaders in Communication Technology
478 E. Exchange St., Akron, OH 44304
(216) 434-3154 TLX: 5101012726

Circle 188 on Reader Service Card

**BUY QUALITY
FOR LESS!
MAXELL**

5 1/4" DS/DD **59¢**

3 1/2" DS/DD **1.15**

LIFETIME WARRANTY

Price based on quantity of 300 in bulk includes Tyvek sleeves and label kits.

800-222-0490

In NJ 201-462-7628
FAX 201-462-5658

- 24 Hour Shipment •

MEGAsoft

P.O. Box 710, Freehold, NJ 07728

Circle 145 on Reader Service Card

RS-422/232 CURRENT LOOP

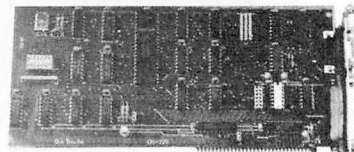

DS-225

- Single channel async communication board for IBM PC/XT/AT
- Software selectable to be RS/422/485, 232 or Current Loop
- Selectable Address & Interrupt

1-800-553-1170



478 E. Exchange St., Akron, OH 44304
(216) 434-3154 TLX: 5101012726

Circle 187 on Reader Service Card

RS-232 FOR PS/2



MODELS 50, 60, 80

- DCE/DTE Selectable
- Transfers to 19.2 K baud
- Address Selectable
- Interrupt Selectable

1-800-553-1170



478 E. Exchange St., Akron, OH 44304
TEL: (216) 434-3154 FAX: (216) 434-1409
TLX: 5101012726

Circle 189 on Reader Service Card

**BUY QUALITY
FOR LESS!
DYSAN**

5 1/4" DS/DD **39¢**

**100% CERTIFIED
LIFETIME WARRANTY**

Price based on quantity of 250 in bulk includes Tyvek sleeves and label kits.

800-222-0490

In NJ 201-462-7628
FAX 201-462-5658

• 24 HOUR SHIPMENT •
MEGAsoft

P.O. Box 710, Freehold, NJ 07728
Full service duplication facility

Circle 146 on Reader Service Card

IBM COMPATIBLES REDUCED BY 20% to 40%

CAT™ 8MHZ BASE SYSTEM

- 256K (Opt. 640K) • 150 Watt Power Supply • AT Style Keyboard & Case
- 4.77 or 8 MHz Keyboard Selectable • FDC
- 8087 Socket • 360K Floppy Drive • 1 Year Warranty

\$39900

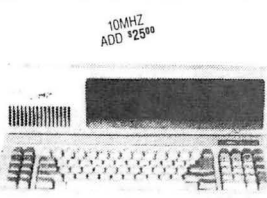

10MHZ
ADD \$2500

CAT 386 SYSTEM

- 12" Amber Monitor
- 1.2 Meg Floppy Drive
- 1 Meg of Memory
- Parallel, Serial & Clock
- 70 Meg Hard Drive

16MHz **\$279900**
20MHz **\$299900**

CAT™ 286-10 BASE SYSTEM

- 512K Exp. to 1 MEG • 200 Watt Power Supply • AT Style Keyboard
- Western Digital Controller • 1.2 Meg Floppy • Legal Bios w/manuals • Systems Documentation • 1 yr war. • Clock/Calc
- 10MHz DTK Motherboard

\$79900

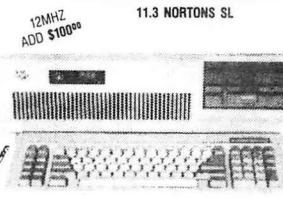

12MHZ
ADD \$1000

11.3 NORTONS SL

OPTION A
12" Mono Amber Monitor
Graphics Card w/par port

\$51900

OPTION B
640 x 200 Color Monitor
Graphics Card w/par port

\$69600

OPTION C
12" Mono Amber Monitor
Graphics Card w/par port
20 Meg Hard Drive

\$78800

OPTION A AT
12" Mono Amber Monitor
Graphics Card w/par port

\$94900

OPTION B AT
640 x 200 Color Monitor
Graphics Card w/par port

\$109600

OPTION C AT
12" Mono Amber Monitor
Graphics Card w/par port
40 Meg Hard Drive

\$139900

(800) 654-7762 ★ FOR LOW PRICES & FAST DELIVERY ★ (800) 654-7762

intel COPROCESSORS

If Your PC Uses the Intel	Running at . . .	Then You Need Intel	MEADS Price
8088	5MHz or less	8087	97 ⁵⁰
8088 or 8086	8MHz or less	8087-2	143 ⁵⁰
8086	10MHz or less	8087-1	209 ⁰⁰
80286	6-8MHz	80287	159 ⁰⁰
80286	8-12MHz	80287-8	229 ⁰⁰
80286	10MHz or more	80287-10	259 ⁰⁰
80386	16MHz	80387-16	387 ⁵⁰
80386	20MHz	80387-20	549 ⁰⁰
80386	25MHz	80387-25	689 ⁰⁰
386SX	16MHz	80387-SX	429 ⁰⁰

VIDEO CARDS

Vega VIDEO7/SEVEN	179 ⁰⁰
Everex EGA 640 x 350 w/par. port	169 ⁰⁰
Everex VGA 640 x 400, 17 VGA Modes	249 ⁰⁰
Everex PGA 640 x 480, 256/4096 Colors	629 ⁰⁰
MEAD Monographics w/par port Hercules comp.	58 ⁰⁰
MEAD Color graphics w/par port Hercules comp.	58 ⁰⁰

ACCESSORIES OF ALL KINDS

150 Watt Power Supply Direct PC Replacement	54 ⁰⁰
200 Watt Power Supply Direct AT Replacement	79 ⁰⁰
Dos 3.2 w/GW Basic	69 ⁰⁰
Everex Ram Expansion for AT or XT starting at	59 ⁰⁰
No Slot Clock	39 ⁰⁰

Seagate HARD DRIVES

COMPLETE KITS	1 YEAR WARRANTY
ST125 20Meg 40 Mil 1/2 Ht	299 ⁰⁰
ST225 20Meg w/cont. & Cables	269 ⁰⁰
ST238 30Meg w/cont. & Cables	299 ⁰⁰
ST251 40Meg 1/2 HT 40 Mil w/software	379 ⁰⁰
ST251-1 40Meg, 28 Mil Sec	469 ⁰⁰
ST277R 60MB 40 Mil 1/2 Ht	489 ⁰⁰
ST4026 20Meg Full HT 40 Mil	279 ⁰⁰
ST4038 30Meg 40 Mil Full Ht	309 ⁰⁰
ST4053 40MB 28 Mil Full Ht	519 ⁰⁰
ST4096 80Meg Full HT w/software	649 ⁰⁰
Fastrax Software	49 ⁰⁰

MODEMS BY SEVEREX™

EV-923 EverCom 12 300/1200 bps Bitcom Software	74 ⁰⁰
EV-941 EverCom 24 2400 Baud Int. Bitcom Software	139 ⁰⁰
EV-945 External 2400 Baud	199 ⁰⁰
For error correcting add \$10.00	
Hayes Compatible Major Manufacturers	
1200 Baud Internal w/Software	59 ⁰⁰
1200 Baud External fully Hayes Compatible	99 ⁰⁰
2400 Baud Internal 1/2 card w/software	109 ⁰⁰
2400 Baud External Fully Hayes Compatible	129 ⁰⁰
1 Year Warranty	

TAPE BACKUPS BY SEVEREX™

40MB Mini Cartridge, 1.8MB/min, XT	359 ⁰⁰
40MB Mini Cartridge, 3.6MB/min, AT	359 ⁰⁰
40MB Streaming Cassette, 5MB/min w/cont.	589 ⁰⁰
60MB Streaming Cassette, 5MB/min w/cont.	649 ⁰⁰
60MB Streaming 600A, 5MB/min w/Full cont.	849 ⁰⁰
125MB Streaming Cartridge, 5MB/min w/Full cont.	1199 ⁰⁰
Excell 60 Model 60/80	999 ⁰⁰
Excell 125 Model 60/80	1269 ⁰⁰
External Add 195 ⁰⁰	

CONTROLLERS BY WESTERN DIGITAL

WX-1 8 Bit 1/2 Sized for XT	69 ⁰⁰
WA-2 16 Bit Full Sized Hard/Floppy	119 ⁰⁰
WD-27X 8 Bit RLL 1/2 Size	79 ⁰⁰
WAH 16 Bit Hard Drive Controller	129 ⁰⁰
RA2 16 Bit RLL Hard/Floppy for AT	159 ⁰⁰
MEAD Floppy Disk Controller for XT	29 ⁰⁰
MEAD 1.2 Meg & 360K Controller for XT	59 ⁰⁰
Cable Set for Hard Drive Only	5 ⁰⁰

MONITORS BY SAMSUNG

1252 12" Amber w/Tilt & Swivel Base	79 ⁰⁰
1257 12" Amber Flat Screen 720 x 350	99 ⁰⁰
1464 14" Color 640 x 200, 16 colors	239 ⁰⁰
1453 14" EGA 640 x 350, 64 colors/31	369 ⁰⁰
CN4551 EGA 720x480	439 ⁰⁰
IBM CGA/EGA/PGA/EGA Multisync Compatible	

FLOPPY DRIVES FROM YOUR LOW PRICE LEADER

360K 1/2 Ht. PC Compatible — Mitsumi	69 ⁰⁰
1.2 Meg Mitsubishi Black Face	79 ⁰⁰
720K 3 1/2" Drive w/5/4" mounting	89 ⁰⁰
1.44 Meg 3 1/2" Drive w/5/4" mounting	119 ⁰⁰
360K Tandon TM100-2 Full Ht.	89 ⁰⁰
160K Tandon TM100-1 Full Ht.	39 ⁰⁰

PRINTERS BY

Panasonic	CITIZEN
KXP10801 144CPS	199
KXP10911 192CPS	229
KXP10921 240CPS	379
1592 214CPS 15"	499
1595 288CPS 15"	549
1524 240CPS 24 pin	649
180D 180CPS 9 Pin 10"	179
MSP40	379
MSP45	479
Parallel 6 ft. Cable \$14 ⁰⁰	

Liquidation ★ Closeouts ★ Discounted Items ★ Overstocked

SAVE UP TO 90% OFF RETAIL — All New 90 Day Warranty**

LETTER QUALITY PRINTER

DAISYWHEEL PRINTER MANUFACTURED BY C.I.TOH

ONLY 280 LEFT

Why pay \$1149 for a C.Itoh

STARWRITER™ F-10

When our 40 cps letter quality daisywheel printer from the same manufacturer is only

\$29900
ea.

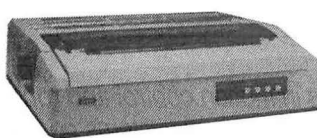

OPTIONS

- 6 ft. Serial Cable \$ 1900
- Bidirectional Tractor 14900
- Cut Sheet Feeder 19900
- Serial to Parallel Converter 9900

STANDARD FEATURES

- 40 CPS • Accepts Paper to 15 inches • Form Length and Pitch Set from Control Panel
- Industry compatible ribbon, printwheels and control commands • RS232 Serial Interface

RAM UPGRADES

4164 150 NS	2 ⁹⁵	41256 100 NS	127 ⁵
4164 120 NS	3 ²⁰	41256 80 NS	137 ⁵
4164 100 NS	3 ⁴⁵	4464 150 NS	15 ⁹⁵
41256 150 NS	11 ⁴⁵	1Meg x 1 120 NS	37 ⁰⁰
41256 120 NS	11 ⁷⁵	1Meg x 1 100 NS	39 ⁰⁰

Attached to the CRT face and keyboard, Static Buster works just like a sponge, dissipating static at a rated 20,000 volts in less than two seconds.

List 79⁰⁰ Mead 19⁰⁰

STATIC BUSTER

Attached to the CRT face and keyboard, Static Buster works just like a sponge, dissipating static at a rated 20,000 volts in less than two seconds.

List 79⁰⁰ Mead 19⁰⁰

REAL MICROSOFT MOUSE

- In Port w/Bus Interface
- Includes Showpartners and Paintbrush
- Full IBM Compatible

List 195⁰⁰ Mead 59⁰⁰

10 MEG HARD DISK KIT

Includes Controller & Cables
• 1/2 Height • 80 Msec
New/Major Manufacturer

Mead 179⁰⁰

1200 BAUD MODEM

• Hayes Compatible w/software
• Auto Answer / Auto Dial
• 1/2 Card Internal

List 99⁰⁰ Mead 54⁰⁰

AT STYLE / XT CASE

• 2 Bay Standard AT Style Case
• Keylock Power and Hard Drive LED's

List 99⁰⁰ Mead 29⁰⁰

800-654-7762

SALES: 7 a.m.-6 p.m. PST

702-294-0204

CUSTOMER SERVICE / ORDER STATUS:
9 a.m.-4 p.m. PST

FAX 702-294-1168



NO SURCHARGE FOR MC/VISA

TERMS:

MC • VISA • COD • CASH

Purchase Orders from Qualified Firms

Personal Checks • AE add 4%

20% Restocking Fee on Non-Defective Returns



Trademarks are Registered with their respective Co's. Prices Subject to Change.
*Offer exp. 2/28/89. Good on prepaid check orders for UPS ground shipping only.
**RAM not include. All are new. 90 Day warranties.
All RAM items subject to price change.
All Products 90 Day Warranty unless stated otherwise.

1000 Nevada Hwy. • Unit 101 • Boulder City, NV 89005

WE ALSO PURCHASE EXCESS INVENTORY — FAX LIST

SHIPPING: (min. 6²⁵) UPS



A-BUS™ NEWS

REMOTE DATA ACQUISITION AND CONTROL

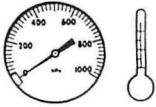

Although affordable, powerful and easy to use, the A-BUS I/O system until recently had a major limitation: it had to be located close to the controlling computer. Now two new serial adapters from Alpha Products have removed this restriction. Any computer with an RS232 port can control the A-BUS line of data acquisition and control cards. Using standard telephone type cable, the A-BUS system can be located up to 500 feet away from the computer. With the addition of a Modem the A-BUS system can be controlled from anywhere. As with all A-BUS cards, the adapters are easily installed and are programmed using standard commands.

NEW SERIAL PROCESSOR HAS BRAIN



Besides implementing a full A-BUS on a serial port, the low cost SP-127 A-BUS Serial Processor fills a great need in remote data acquisition. It includes a complete BASIC interpreter and can run programs independently of the host computer. This distributed processing relieves the host of housekeeping chores and low level decision making. The SP-127 can read and log data at set intervals for later reviewing or recalling at the host's convenience. The Serial Processor, which communicates with any computer through an RS232 port, includes a complete BASIC interpreter and 32K of memory. Adding a Modem turns the SP-127 into a automated remote data and control station.

THE A-BUS ON NETWORK

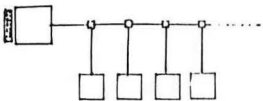

Unique features such as the new "Serial Nodes" greatly expand the usefulness of the A-BUS. These inexpensive (\$49) devices provide the ability to connect up to 16 complete A-BUS systems to a single serial port on any computer. The node also functions as a repeater to increase the reach of the adapter beyond the 500 foot limit. The nodes work in conjunction with the company's SA-129 Serial A-BUS Adapter. Plant-wide data collection and control will become widespread thanks to the system's low cost, outstanding capabilities, and ease of use.

ADVANCE IN MOTION CONTROL

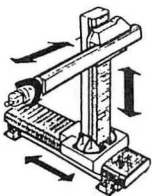

Seeking new heights in motion control and robotics, Alpha's Smart Quad Stepper Controller outperforms systems costing 5-10 times more. This \$299 board includes a multitasking microprocessor capable of controlling 4 stepper motors simultaneously at speeds up to 1000 steps per second. Four Axis positioning is perfect for robot arms, positioners, pick and place, etc. Commands are intuitive; plain English words and a forgiving syntax make it easy to write (and edit) command sequences. Scaling factors allow for meaningful units of your choice, and 32 bit floating point arithmetic ensures accurate calculations. The "learn" feature involves storing a series of movements so that even a complex sequence can be repeated easily. Alpha's engineers thoughtfully included direct drivers for small motors, and a variety of inputs (limit switches, remote keypad, panic button, etc.). An SC-149 can be set up quickly and easily, minimizing development time and allowing more effort to be devoted to the rest of the robotic project.



ALPHA Products

(203) 656-1806

Darien, CT 06820

A-BUS™ MAGIC

Classroom to advanced industrial applications.

Be a Wizard in your Lab, Factory, College, Home...

It used to be difficult and costly to do process control, robotics, data acquisition, monitoring and sensing with your computer. Now the low-cost A-BUS system makes it easy to do almost any project you can imagine.

Versatility. A-BUS cards handle most interfacing, from on/off switching, to reading temperatures, to moving robot arms, to counting events, to sensing switches...

Adaptability. The A-BUS is modular, allowing expansion well beyond your needs. It works with almost any computer, or even as a remote data station with the new serial adapters.

Simplicity. You can start using the A-BUS in minutes. It's easy to connect, and software is a breeze to write in any language.

Reliability. Careful design and rugged construction make the A-BUS the first choice in specialized I/O.

An A-BUS system consists of: = An A-BUS adapter plugged into your computer = A cable to connect the adapter to 1 or 2 A-BUS function cards. = The same cable will also fit an A-BUS Motherboard for expansion to up to 25 cards in any combination.

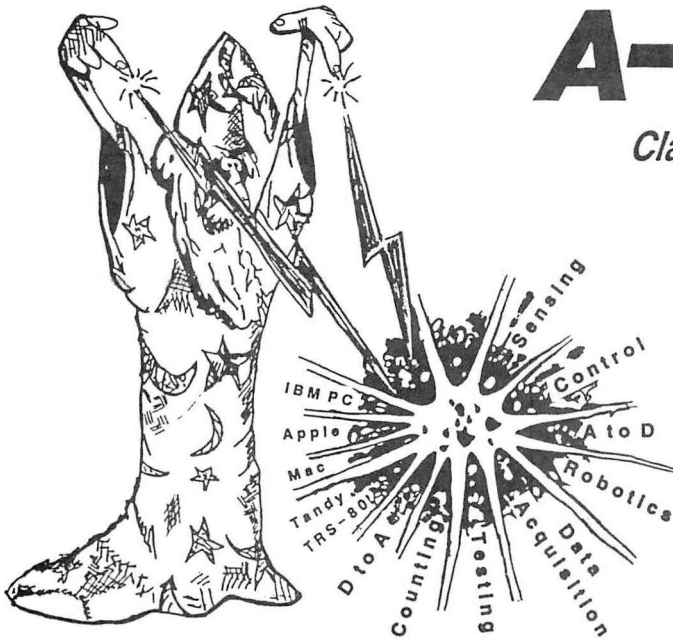

NEW: REMOTE A-BUS! Use the new Serial (RS-232) Adapter or Processor to control any A-BUS system. Cards can be up to 500 ft away using phone type cable, or off premises using a modem. Call or send for the new A-BUS Catalog which covers all the products.

Important

All A-BUS Systems: ♦ Come assembled and tested ♦ Include detailed manuals with schematics and programming examples ♦ Can be used with almost any language (BASIC, Pascal, C, assembler, etc.) using simple "IN" and "OUT" commands (PEEK and POKE on some computers) ♦ Can grow to 25 cards (in any combination) per adapter ♦ Provide jumper selectable addressing on each card ♦ Require a single low cost unregulated 12V power supply ♦ Are usually shipped from stock. (Overnight service is available.)

About Alpha Products

Founded in 1976 for the purpose of developing low cost I/O devices for personal computers, Alpha has grown to serve over 70000 customers in over 60 countries. A-BUS users include many of the Fortune 500 (IBM, Hewlett-Packard, Tandy, Bell Labs, GM...) as well as most major universities. A-BUS products are U.S. designed, U.S. built, and serviced worldwide. Overseas distributors: England: Cald Science Assoc. Ltd., Merseyside, 051 342 7033. Australia: Brumby Technologies Pty. Ltd., NSW, 759 1638. France: Coserm, Rungis, 46 86 64 75

Inputs, Outputs, etc.

Analog Input: 8 analog inputs. 0-5.1V in 20mV steps (8 bits). 0-100V range possible. 7500 conversions/second. AD-142: \$142

12 Bit A to D: Analog to digital converter. Input range -4V to +4V, expandable to 100V. On-board amplifier. Resolution 1mV. Conversion time 130ms. 1 channel. (Expand to 8 channels with the RE-156 card.) AN-146: \$153

Relay Card: 8 individually controlled industrial relays each with status LED's (3A at 120VAC contacts, SPST). RE-140: \$142

Reed Relay Card: 8 reed relays (20mA at 60VDC, SPST). Individually controlled and latched, with status LEDs. RE-156: \$109

D/A converter: 4 Channel 8 Bit D/A converter with output amplifiers and separate adjustable references. DA-147: \$149

24 line TTL I/O: Connect 24 input or output signals (TTL 0/5V levels or switches). Variety of modes. (Uses 8255A) DG-148: \$72

Digital Input: 8 optically isolated inputs. Input can be 5 to 100V voltage levels or switch closures. IN-141: \$65

Digital Output Driver: 8 outputs: 250mA at 12V. Drive relays, solenoids, stepper motors, lamps, etc. ST-143: \$78

Clock with Alarm: Powerful clock/calender. Battery backup. Timing to 1/100 sec. Alarm relay, LED and buzzer. CL-144: \$98

Touch Tone Decoder: Each tone is converted into a number which is stored on the board. PH-145: \$87

A-BUS Prototyping card: 4x4.5" card. Will accept up to 10 I.C.s. With power & ground bus. PR-152: \$16

Counter Timer: Three 16 bit counters/timers. Use separately or cascade for long (48 bit) counts. CT-150: \$132

Call our application engineers to discuss your project.

Ordering Information: We accept Visa, Mastercard, Checks, and M.O. C.O.D. is \$4 extra. Purchase orders are subject to credit approval. CT residents add 7.5% sales tax. Shipping: \$4 per order (usually UPS ground). UPS 2nd Day Air: \$4 extra. Next Day service available. Canada: \$6 per order (Airmail). Outside US and Canada: Add 10% of order total.

Circle 12 on Reader Service Card

Motion Control

Smart Quad Stepper Controller: The world's finest.

On board microprocessor controls four motors simultaneously. Uses simple English commands like "MOVE ARM 10.2 (INCHES) LEFT". For each axis, you control coordinates (absolute or relative), ramping, speed, units, scale factors, etc. Many inputs for limit switches, etc. On the fly reporting of speed, position... Built in drivers for small motors (such as MO-103 or 105). SC-149: \$299
Options: ▶ 5 amp/phase power booster for 1 motor: PD-123: \$49
▶ Remote "teach" keypad for direct motor control: RC-121: \$54

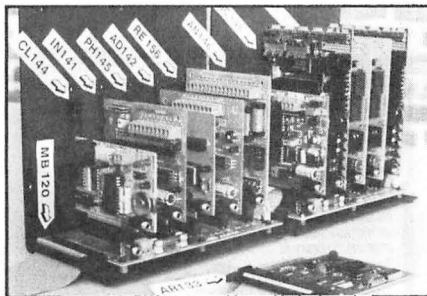

A large A-BUS system with two Motherboards. Adapter in the foreground plugs into PC, XT, AT type slot.

Stepper Driver Kit: For experimenting with stepper motors. Includes 2 MO-103 motors and a ST-143 dual driver PA-181: \$99

Stepper Motors: (4 phase, unipolar)
MO-103: 2 1/4" dia. 1/4" shaft. 7.5"/step. 12V. 5 oz-in torque. \$15
MO-104: 2" dia. 1/4" shaft. 1.8"/step. 5V. 60 oz-in torque. \$45
MO-105: 1.7" square. .2" shaft. 3.75"/step. 12V. 6 oz-in. \$15

A-BUS Adapters

- ▶ Can address 64 ports and control up to 25 A-BUS cards.
- ▶ Require one cable. Motherboard required for more than 2 cards.

A-BUS Parallel Adapters for:

IBM PC/XT/AT & compatibles. Uses one short or long slot.	AR-133: \$69
Apple II, II+, IIe Plugs into any slot inside.	AR-134: \$42
Commodore 64, 128 Plugs into Expansion Port on back.	AR-139: \$48
TRS-80 Model 102, 200 Uses 40 pin "System bus".	AR-136: \$76
Model 100 (Tandy portable) Plugs into socket on bottom.	AR-135: \$75
TRS-80 Model 3, 4, 4D Y-Cable available if 50 pin bus is used.	AR-132: \$54
TRS-80 Model I Plugs into 40 pin expansion bus.	AR-131: \$39
Tandy Color Computers Fits ROM slot, Multipack or Y-Cable	AR-138: \$49

A-BUS Cable: Necessary to connect any parallel adapter to one A-BUS card or to first motherboard. 50 pin. 3 ft. CA-163: \$24
Special Cable for two A-BUS cards CA-162: \$34

Serial Adapter: Connect A-BUS systems to any RS-232 port. Allows up to 500 ft from computer to A-BUS. SA-129: \$149

Serial Node: To connect additional SA-129/A-BUS systems to a single RS232 serial port (max 16 nodes). SN-128: \$49

Serial Processor: same as above plus built in BASIC for off-line monitoring, logging, decision making, etc. SP-127: \$189
Use SA-129 or SP-127 with modems for remote data acquisition.

Motherboard: Holds up to 5 A-BUS cards in sturdy aluminum frame with card guides. A sixth connector allows (using cables CA-161: \$12) additional Motherboards to be added. MB-120: \$108

Power Supply: Power pack for up to 4 cards. PS-126: \$12

Complete Catalog Available
For Orders and Info call (203) 656-1806
Weekdays from 9 to 5 EST or FAX 203 656-0756



ALPHA Products

242-B West Avenue, Darien, CT 06820

FEBRUARY 1989 • BYTE 333

Protect Your Copies of BYTE

NOW AVAILABLE:
Custom-designed library files or binders in elegant blue simulated leather stamped in gold leaf.

Binders—Holds 6 issues, opens flat for easy reading.
\$9.95 each, two for \$18.95, or four for \$35.95.



Files—Holds 6 issues.
\$7.95 each, two for \$14.95, or four for \$27.95.



Order Now!

Mail to: Jesse Jones Industries, Dept. BY,
499 East Erie Ave.,
Philadelphia, PA 19134

Please send _____ files;
_____ binders for BYTE magazine.

Enclosed is \$_____. Add \$1 per file/binder for postage and handling. Outside U.S.A. add \$2.50 per file/binder (U.S. funds only please).

Charge my: (minimum \$15)

_____ American Express _____ Visa
_____ MasterCard _____ Diners Club
Card # _____ Exp. Date _____
Signature _____

CALL TOLL FREE (24 hours):
1-800-972-5858

Name _____
Address _____ (No P.O. Box)
City _____
State _____ Zip _____

Satisfaction guaranteed.
Pennsylvania residents add 6% sales tax.
Allow 5-6 weeks delivery in the U.S.



IMAGING CARD



DV-01 GRAY SCALE FRAME GRABBER

Composite video in/out
256 x 240 resolution
Digitize/display at frame speed
256 gray levels in
16 Meg. color palette out
PC/XT/AT compatible
\$849.00 Complete with software
VISA/MC Demo Disk available
Control Vision
P.O. Box 596, Pittsburg, KS 66762
(316) 231-6647

Circle 66 on Reader Service Card

TurboFlow \$69

Flowchart drawing for IBM PC/XT/AT/PS2

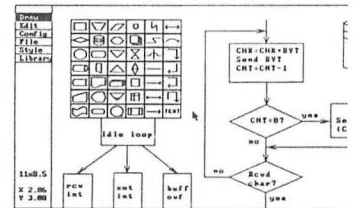

\$89 with Logitech mouse!

- Pop-up icon menus
 - Variable size symbols
 - Paper size to 34" x 44"
 - Hercules mono, CGA, EGA
 - HP-GL, DM/PL, SweetP Plotters
 - Automatic PANning to scan drawing quickly
 - IBM/EPSON, NEC, OKIDATA, HP LaserJet
- Daytron Electronics Inc.
610 S. Sherman #104, Richardson, Tx 75081
Add s.&h (\$4 USA, \$15 foreign), Texas residents add 8% sales tax
for technical information call 214-669-2137
Order Today! 1-800-882-5822
Money-back guarantee

PAL/EPROM PROGRAMMER for PC

VERSION 2 of Software and Hardware \$475

- Programs 20 and 24 pin MMI, NS, TI, Altera, Cypress, Ricoh/Panasonic PALs. EPLD (UV erasable), polarity, and RA types.
- Functions include: read, write, verify, protect, edit, print, and file load and save of program.
- JEDEC files supported.
- 2716-27512 EPROMs.
- Functions include: read, write, verify, blank check, HI/LO split, edit in ASCII, HEX, or Decimal.
- INTEL Hex and Motorola 'S' Record file support.

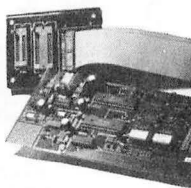

200/100 MHz LOGIC ANALYZER for PC

LA27100 \$1299
LA27200 \$1899

- 24 Channel mode with 4K/channel • 6 Channel mode with 16K/channel
- Internal Rates from 200MHz (LA27200) or 100MHz (LA27100) to 250 Hz
- External Clock from DC to 50 MHz • 16 Level Triggering Sequence
- Threshold Voltage Level at TTL, ECL, or -8V to +14V variable • Data Display as Timing Diagram or State List • Save/Load Data and Setup Info.

(201) 994-6669

Link Computer Graphics, Inc.
4 Sparrow Dr., Livingston, NJ 07039

Circle 128 on Reader Service Card

ON TARGET ASSOCIATES

Products and Services
for Design and Manufacturing Engineers.

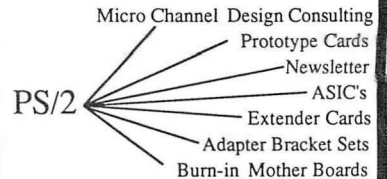

We will move your PC/XT/AT products to the Micro Channel, or create your new design.

CALL: (408) 980-7118
for our Free catalog

ON TARGET TARGET TARGET

...the PS/2 leaders.

PS/2 and Micro Channel are trademarks of IBM Corp.

Circle 171 on Reader Service Card

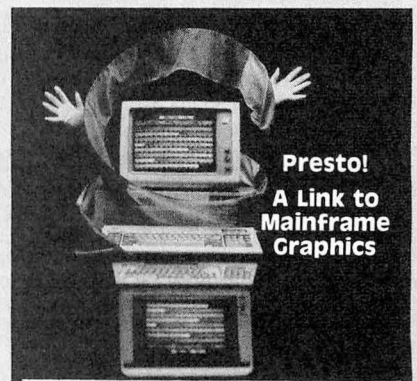

Find out how our whole family of EMU-TEK graphics terminal emulation software makes good sense for the work you do. Call today for more information.

FTC DATA SYSTEMS

(714) 995-3900
(800) 962-3900 (800) 972-3900 (Calif.)
10801 Dale St., Suite M-2
Stanton, CA 90680

Circle 94 on Reader Service Card

FREE! The PC SYSTEMS HANDBOOK FOR SUBSISTERS and MANAGERS
Data Acquisition & Instrumentation for Your PC - A User's Guide & Companion

Turn-key PC Systems Handbook

NEW 1988 Fall/Winter Edition

Save Time and Money
Over 1000 Hard-to-find Hardware and Software Items of Special Interest to Technical PC Users:

144 Pages Available Now

In a hurry? Call 203-786-5151 Ext 101

- RS 232/IEEE 488 Networks
 - Stepping & Servo Motor Controls
 - Ruggedized PC's
 - Rack Mtg. 80286 & 80386
 - Laboratory Automation
 - 1 MHz A/D
 - Digital Scopes to 200 MHz
 - High Speed Bus Adapters
 - Waveform Synthesizers
 - Data Loggers
 - PC Bus Expansion Chassis
 - And Much More
- A How-to-Handbook that enables you to configure the BEST products from the world's leading PC hardware and software vendors into risk free turn-key system solutions that meet your needs.
- Toll Free Hotline for application assistance and convenient one stop shopping at competitive prices. 100% Satisfaction Guaranteed.

Call or write for a FREE handbook today!
203-786-5151 Ext. 101
(9:00 AM to 5:00 PM E.S.T.)
CyberResearch, Inc.
P.O. Box 9565, New Haven, CT 06536
Fax: 203-786-5023 Telex: 9102501037

Circle 68 on Reader Service Card

Opto-Mechanical Mouse \$29

1200 Baud Modem Modem \$48

Jade 10 MHz Turbo XT\$398
640K Motherboard w/256K RAM
Floppy Disk Controller
140 Watt Power Supply
101 Enhanced Keyboard

Monochrome Graphics System *698
640K RAM, 360K Disk Drive
Printer Port, Amdek 310A Monitor
30 MB Hard Disk System ... add \$298
CGA Color System add \$188
EGA Color System add \$398
VGA Color System add \$568

Jade 10 MHz Turbo 286\$845
1 MB Motherboard w/640K RAM
200 Watt Power Supply
Clock/Calendar
Enhanced 101 Keyboard

Mono Graphics System \$1098
1.2 MB Floppy Drive & Controller
Printer Port, Amdek 310A Monitor
40 MB Hard Disk System ... add \$438
12 MHz, 1 MB of RAM add \$148

Jade 20 MHz Turbo 386 \$1998
1 MB of RAM on Motherboard
1:1 Interleave FDD/HD Controller
2 Serial, 1 Parallel, Clock, Calendar
101 Enhanced Keyboard

40 MB Mono Graphics System*2388
1.2 MB Floppy Disk Drive
40 MB Hard Disk Drive
Amdek 310A Monitor

Disk Drives
360K half height\$68
360K full height\$88
TEAC 55 BV\$78
1.2 MB for AT\$88
3 1/2" 720K\$88
3 1/2" 1.44 MB\$118
5 1/4" ext. 360K for PS/2\$218
5 1/4" ext. 1.2 MB for PS/2\$258

Hard Disk Drives
10 MB w/controller\$198
20 MB w/controller\$268
30 MB w/controller\$288
40 MB w/controller\$398
40 MB for AT\$338
ST 125 20 MB\$248
ST 138 30 MB\$298
ST 251 40 MB\$368
ST 251-1 40 MB\$448
ST 4096 80 MB\$568

Tape Back-up
Mountain 40 MB XT\$378
Mountain 40 MB AT\$378
Mountain external 40 MB\$498
CMS 60 MB tape\$498

Monitors
Amdek 310A amber\$98
Amdek 410A\$118
14" amber flat screen\$128
RGB 640 X 240 Color\$258
EGA 640 x 350 color\$378
VGA 800 x 560\$488
NEC MultiSync GS\$188
NEC MultiSync II\$588
NEC MultiSync Plus\$888
NEC MultiSync XL\$2068
Mitsubishi Diamond Scan\$498
Zenith 1490 flat screen\$618
Sony 800 x 600 Multi Scan\$488

Keyboards
84 Key At-style\$68
101 Key enhanced\$78

Printers
EPSON LX-800 9 PIN\$188
EPSON FX-850 Call
EPSON FX-1050 Call
EPSON EX-800 Call
EPSON LQ-500 24 PIN\$299
EPSON LQ-850 Call
EPSON LQ-950 Call
EPSON LQ-1050 Call
EPSON DFX-5000 Call

Okidata 320\$338
Okidata 321\$468
Okidata 390\$468
Okidata 391\$638
Okidata 393\$928

Citizen 120D\$158
Citizen 180D\$168

NEC P2200\$358
NEC P5200\$528
NEC P5300\$698

Diconix 150 Portable\$308

Daisywheel Printer
40 CPS Parallel and serial\$248

Hewlett Packard DeskJet
DeskJet\$698
128K PDP Desk RAM\$98
EPSON emulation cartridge\$68
TMS RM/HELV Soft Font\$98
Ink cartridge\$19

Hewlett Packard LaserJet
LaserJetIII Call
25 in One Font Cartridge\$398
4 MB card w/0 memory\$188
1 MB memory card\$348
2 MB memory card\$648
4 MB memory card\$1148
Toner cartridge\$98

Terminals
WYSE model 30\$288
WYSE model 50\$368
WYSE model 85\$438

Joystick
Kraft 3 button Joystick\$19
Dual Game Port\$19

Plotter
Roland DXY 885\$898
Houston Instruments Call
Hewlett Packard all models Call

Scanner
Complete Hand Scanner\$178
Logitech Scan Man\$248
Diamond Flower 3000\$248
Hewlett Packard ScanJet Call

Digitizers
Summa Sketch 12 x 12\$378

Mouse with Software \$29

LogiTech
LogiMouse Bus\$78
LogiMouse Serial\$78
LogiMouse Hi-rez\$88

Mouse Systems
PC Mouse with Paint\$88

Microsoft
Mouse w/Paintbrush\$98
Mouse w/CAD Call
Mouse w/Window Call

Complete PC
Complete Hand Scanner\$178
Complete FAX 4800\$298
Complete FAX 9600\$458
Complete Answering Machine\$248

Switch Boxes
Parallel or Serial (Specify)
2 way AB\$28
3 way ABC\$38
4 way ABCD\$58
5 way ABCDE\$68
Crossover X\$68
AutoSwitch 3 way\$198
AutoSwitch 6 way\$248

Modems
1200 internal w/software\$48
2400 internal w/software\$98
1200 external\$88
2400 external\$158
2400 PS/2 internal\$178
Intel 2400B for PS/2\$278

Intel
8087\$98
8087-2\$143
8087-1\$198
80287-6\$158
80287-8\$228
Above board PC 64K\$268
Above board 286 512K\$468
In board 386\$1098

Cables
6' printer\$12
10' printer\$18
25' printer\$28
9' serial\$18
25' serial\$28
50' serial\$38
100' serial\$58
Keyboard extender\$12
Monitor extender\$16
Printer extender\$16

Boards
Monographics w/Parallel\$48
Color Graphics w/Parallel\$48
EGA card\$148
VGA card\$258
AST EGA Par/Ser/Clock\$168
Dual game port\$19
XT I/O Par/Ser/Clk/Game\$58
AT I/O Par/Ser/Game\$58
360/720K 1.2/1.44 MB FDC\$48
AT FDD/HD controller\$128
XT Hard Disk controller\$58
AST SixPak Plus\$118
AST XFormer\$578
Paradise auto EGA 350\$168
Paradise VGA+\$268

Surge Protector
S. L. Waber 6 outlet\$18
Isobar 4 outlet\$48
Isobar 8 outlet\$68
Isobar modem protector\$24

Tripplite Battery Back-up
450 Watt UPS\$398
750 Watt UPS\$498
1200 Watt UPS\$698

Tripplite Line Stabilizer
600 Watt LC\$98
1200 Watt LC\$158
1800 Watt LC\$188

Accessories
Kensington Master Piece\$88
MicroSpeed PC-Trac Ball\$78
Vertical CPU stand\$18
Keyboard drawer\$58
Monitor Tilt-n-Swivel\$18

4901 W. Rosecrans Ave. Box 5046
Hawthorne, California 90251-5046



California

Torrance, Santa Ana, Woodland Hills

Kearny Mesa, Sunnyvale

Texas

Addison, Houston

Georgia

Arizona

Smyrna

Phoenix

Not all items in stock at
our nine retail locations.

JADE COMPUTER

Place orders and use our technical support toll free!

Continental U.S.A. 1-800-421-5500 Inside California 1-800-262-1710

Fax machine 1-213-675-2522/All others 1-213-973-7707



We accept checks, credit card or purchase orders from qualified firms and institutions. No surcharge on credit card orders. CA., TX, GA. & AZ. residents add sales tax. Prices and

availability subject to change without notice. Shipping and handling charges via UPS ground 50¢/lb. UPS air \$1.00/lb. Minimum charge \$3.00.

SPEECH PRODUCTS

For PCs and compatibles
SYNTHESIZER—only \$79.95



The next versatile and best sounding speech product available for under \$400! The amazing **Speech Thing** provides text-to-speech as well as PCM and ADPCM speech and music reproduction. Comes with "Thing" D/A converter that attaches to the parallel printer port outside the computer—ideal for laptops. Will not interfere with normal printer operation. Also comes with audio amplifier/speaker and power adapter. Software includes two advanced text-to-speech programs, digitized speech and music files, full screen waveform editor, sampling music keyboard, special effects mixing board, and drivers so you can add speech and sound effects to programs written in BASIC, C, PASCAL, and others. Includes 54 page manual. **SPEECH THING—\$79.95.**

DIGITIZER—only \$89.95

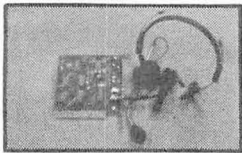

The **Voice Master PC Digitizer** is a full 8-bit PCM sampler board. Fits in any available slot. Up to 15,000 samples per second. Input pre-amp has automatic gain control and 4.5 KHz low pass filter. Includes a quality headset microphone. Software included for recording and editing sound files for playback through **Speech Thing**. Also includes a real-time spectrum display and oscilloscope display as well as assembly language source listings for writing your own drivers. **BONUS:** Voice recognition program included which is callable via an interrupt vector. Demonstration program written in GWBASIC. **VOICE MASTER PC DIGITIZER—\$89.95.**

VOICE RECOGNITION—only \$49.95

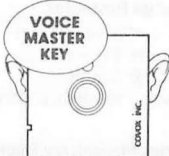

A price/performance break-through! Equal in performance to other systems costing hundreds more \$\$\$! The amazing **Voice Master Key** program adds voice recognition to just about any program or application. You can voice command up to 256 keyboard macros. Fully TSR and occupies less than 64K. Instant response time and high recognition accuracy. Easy and fun to use—no compilers or editors required. Works with CAD, desktop publishing, word processor, spread sheet, even other TSR programs. A genuine productivity enhancer. **Voice Master Key** can also be called from within a program for adding voice recognition to custom applications. **Voice Master Key** requires the **Voice Master PC Digitizer** for operation. (Please note: **Voice Master Key** will not replace the keyboard or mouse except under certain circumstances. Not to be confused with the still unavailable "voice typewriter.") **VOICE MASTER KEY—\$49.95.**

BONUS OFFER! Buy **Voice Master Key** with **PC Digitizer** for only \$129.95—you save \$10!
BETTER BONUS OFFER! Buy all three: **Speech Thing**, **PC Digitizer**, and **Voice Master Key** for only \$189.95—you save \$20!
ALL OF THESE PRODUCTS ARE OF PROFESSIONAL QUALITY.

ORDER HOTLINE: (503) 342-1271

Monday-Friday, 8 AM to 5 PM Pacific Time

Add \$5 for shipping and handling on all orders. Add an additional \$3 for 2nd day delivery. All goods shipped UPS. Master Card and VISA, money order, cashiers check or personal checks accepted (allow a 3 week shipping delay when paying by personal check). Foreign inquiries contact Covox for C&F price quotes. Specify computer type when ordering. **30 DAY MONEY BACK GUARANTEE IF NOT COMPLETELY SATISFIED. ONE YEAR WARRANTY ON HARDWARE.** Call or write for **FREE** product catalog.



COVOX INC. 675-D CONGER ST.,
EUGENE, OREGON 97402 U.S.A.
TEL: 503-342-1271 FAX: 503-342-1283

The UnVT



The clear alternative
to DEC terminals!
VT220, VT241, D400 emulators.



SYSTEMS LTD.
2150 West Broadway, Suite 412
Vancouver, B.C. Canada V6K 4L9
Tel: 604-732-7411 Fax: 604-732-0715

Circle 121 on Reader Service Card

EPROM PROGRAMMER CROSS ASSEMBLERS



MODEL
SX151

RS232C OR STAND ALONE (all models), Communication protocol: XMODEM, HEX, and BIN. Programs: EEPROMS, 2716 - 27512 and CMOS. Programs (w/adaptor): 25XX, 27101 (and above), 68701, 68705, 68764/6, 8741/2, 8744, 8748/9, 8751/2, 8755, 87252, and CMOS. More available soon. **Model SX151 \$214** (assembled with case). Other models are available from \$49 (kit).

Cross assemblers by PseudoCode for IBM-PCs \$35. Z80, 1802, 6502, 6800/1/2/3/5/8/9/11, 68000/8/10 8048/9, 8051/2, 8080/5, 8096, and more soon.



KORE, Inc.
6910 Patterson S.E.
Caledonia, MI 49316
(616) 791-9333

\$5 for shipping (USA), plus \$3.00 COD.

Circle 123 on Reader Service Card

NEW! MCPM-3 for
MC68HC05 Family!



6805/6305
SINGLE CHIP

MICROCOMPUTER DEVELOPMENT SYSTEMS

Each of three products allows the IBM PS2/PC/XT/AT to be used as a complete development system for the **Motorola 6805** series single chip microcomputers. **MCPM-1** supports the **MC68705** family, **MCPM-2** supports the **MC1468705** family and **MCPM-3** supports the **MC68HC05** family. Each system is \$495 and includes a programming circuit board or programmer with driver, cross assembler and simulator/debugger software. A system is also available for the **HITACHI 63705 ZTAT** micro.

THE ENGINEERS COLLABORATIVE

Route 3, Box 8C, Barton, VT 05822
(802) 525-3458 FAX (802) 525-3451

Circle 257 on Reader Service Card

THROW AWAY YOUR COMPUTER MANUALS!

Learn Popular Software
Programs With . . .

VIDEO INSTRUCTION TOOLS

Lotus 1-2-3 (4 hours)	\$ 99.95
WordPerfect 5.0 (4½ hours)	129.95
WordPerfect 4.2 (3 hours)	99.95
DOS 3.3 (3½ hours)	129.95
Intro To IBM-PC (1½ hours)	79.95
PageMaker 3.0 - PC (2 hours)	179.95
PageMaker 3.0 - MAC (2 hours)	179.95
Ventura Publisher (2 hours)	179.95
Ventura - techniques (2 hours)	179.95
Q & A (1½ hours)	79.95
MicroSoft Word - MAC 4.0 (2½ hours)	129.95
MicroSoft Works (1½ hours)	79.95
HyperCard - MAC (2 hours)	79.95

These video tapes are self-contained training guides, which demonstrate every command in a given software package, while showing the computer screen and keyboard SIMULTANEOUSLY. Save money . . . call today!

MICHAEL HALVERSON & ASSOCIATES

1313 Newburgh, Westland, MI 48185
(313) 729-0325 / FAX: (313) 729-0238

FOR PRODUCT INFORMATION

1-800-537-1641

MAJOR CREDIT CARDS ACCEPTED

Circle 149 on Reader Service Card

Get the whole story on graphics terminal emulation.



To find out more about software that lets your PC emulate **TEKTRONIX™ 4105/6/7/9** and **DEC VT100™** terminals, call or write:



4340 Stevens Creeks Blvd., Suite 280,
San Jose, CA 95129 (408) 249-7951

Circle 99 on Reader Service Card

JB UNIVERSAL COMPUTER INTERFACE

RS232 ADAPTER TO JB-BUS	\$149
CENTRONICS ADAPTER TO JB-BUS	\$99
The JB universal interface cards can be connected externally to just about any computer with a standard interface. Affordable and portable data acquisition, monitoring & control.	
JBAD8-16 Analog input, 16 ch, 8-bits, gain 1, 10, 100	\$149
JBID064 Digital I/O, 32 TTL inputs, 32 TTL outputs	\$99
JBBAT Battery option, great for laptop computers	\$99

PC COMPATIBLE INTERFACE CARDS

DIGITAL OSCILLOSCOPE SYSTEM \$99

AD8-1 card & DIG-OSC-B Software	
* Analog input	
* 8 bit resolution	
* save waveform to disk	
* 10K samples/sec	
* High input impedance	
* 0-5V range	

DAS 12 (Sale Price ends February 28, 1989) \$249

* 8 hi-Z, 12-bit S.E. Analog input channels	
* GAIN of 1, 10, 100	
* Full Scale: 4/-, 10V, 5V, 500mV, 50mV	
* 25uS conversion	
* software to simulate 8 channel DVM, data logger, plot data	
* 7 TTL I/O, trigger sampling or control external devices	
* 1000 samples/sec	

DAS8F \$199

* high speed (1.5uS conversion) 8-bit data acquisition system	
* 8 hi-Z, S.E. input channels, GAIN of 1, 10, 100, 0-5V Full Scale	
* optional 8-bit analog output, add \$50	

Prices, availability and specifications are subject to change

JB COMPU-TRONIX

3816 N. Wadsworth Blvd.
Wheat Ridge, CO 80033
(303) 425-9586

Call for FREE CATALOG, accept MC/VISA orders

Circle 119 on Reader Service Card

California Digital

17700 Figueroa Street • Carson, California 90248

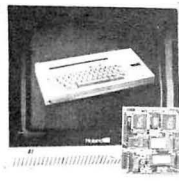

Color Monitor
Better Than **EGA**
~~\$1095~~ **\$289**

Ideal for CAD/CAM and Desk Top publishing applications. The Roland CD/240 color monitor has a resolution of 720 pixels by 400 lines on a .31mm dot pitch 12" non-glare screen. VGA specifications in text mode EGA in graphic mode. Comparable monitor and card packages retail at over \$1095. California Digital has made a special purchase and is able to offer the CD/240 and 132 column VGA/EGA graphic card for only \$389.

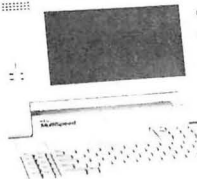

Laptop Blowout \$695
NEC MultiSpeed EL \$2295

A true Backlit Supertwist LCD display!
Take it to school, court or news events. The "EL" Laptop does all the work of a desktop and is portable. Best of all the "EL" functions in areas where little light is available. The ideal computer for anyone who needs computing power on the go!

Spreadsheets, word processing, data bases and telecommunications, a simple task for the MultiSpeed EL. **Two 720 K/Byte 3 1/2" disk drives, MS/DOS. 640 K RAM, NiCad batteries, text editor with 20,000 word spelling checker make the "EL" a super value at \$2295 but at \$695 its a steal.** Also Available: Custom carrying case and internal modem.

20" Analog Color
~~\$1895~~ **\$659**



Ever try gathering a classroom of students around a 12 inch monitor? This 20 inch analog RGB monitor is the ideal solution. High screen resolution of 1200 pixels by 950 lines allow extra fine detail without the dots looking like golf balls. 256 colors and VGA compatible. **Super value originally sold for over \$2000. Only 350 available.**

Build Your Own Computer
~~\$1299~~ **\$359**
AT Case Only

California Digital has all the components needed to customize your own computer. Buy as much computing power as you need now, and upgrade when the need arises. Here are some examples of components available:

8 slot 10 MHz Mother board\$89	Monochrome card, printer port25
8 slot 12 MHz baby AT Motherboard229	MonoGraphics (hercules) printer port45
Full size five drive AT case35	Color Graphics card49
Four drive XT case25	EGA Color Multi Resolution II159
101/102 AT XT German mfg. Keyboard57	I/O card, serial & parallel35
200 watt AT power supply59	I/O PLUS, Ser/Par I, clock, game59
Teac 360K/Byte disk drive59	Disk I/O, disk control, clock, game59

Speech Recognition System
~~\$1195~~ **\$895**



Does your computer listen to you? Install the Voice Scribe and have your computer respond to 1000 word and phrase commands. One word can save over 20 keystrokes. Its faster and more accurate. **Don't Keystroke!** The Voice Scribe makes repetitive data entry simple. Perfect for shipping and inventory control, accounts payable and receivables, controlling machinery or any application where "hands free" is important. The Voice Scribe has assisted many handicapped in home and office environment. **Certified to 99.3% accuracy.** Ideal for security clearance applications. The system can be trained to respond only to your voice. Voice Scribe System is shipped complete with PC card, software, application manual and Shure noise canceling microphone.

40 Meg. Tape Back-up
~~\$659~~ **\$239**



Head Crash, Power Spikes or just poor disk maintenance... Don't loose data because you didn't back up. The ALL/40 is an inexpensive way to save and restore files in the event that your data has been destroyed. This 40 megabyte half height tape back is manufactured by North Americas largest producer of data retrieval equipment. No need to purchase a separate tape controller... the ALL/40 attaches directly to your existing floppy disk controller. Supplied software allows your computer to back up any time **Day or Night.** Come back in the morning and 40 megabytes of irreplaceable data has been stored on one Scotch DC/2000 data cassette. Back up entire hard disk, modified files only, or by file name. Loss of data is inevitable but when you are backed up on an ALL/40 its not a catastrophe.

Scanner
~~\$1299~~ **\$359**

The Saba Scanner inputs a printed page in less than three seconds. OCR software allows your computer to transfer printed pages into ASCII files or directly to spreadsheets and word processing programs. Archival data, legal briefs... No problem. Simply insert the page into the Saba and in seconds the document is digitized into your computer and ready for editing. Limited quantities available. Original price \$1299, now only \$359.

Digitizers
\$259
As Low As



California Digital offers over 100 different digitizers. We have two which appear to offer the best values. Both are 12" by 12", one thousand line per inch resolution, are supplied with four button cursor and stylus. The first digitizer is the Genius Tablet priced at only \$259. This is a new product from KYE of Taiwan. The other unit, pictured above, is the Puma Pro manufactured by Hitachi and warranted for ten years. The Puma boast a .0015" repeatability... only \$359.

Hitachi 11 by 17 Plotter
~~\$895~~ **\$695**

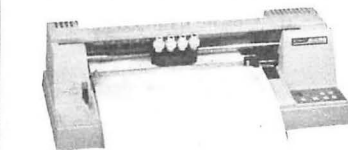

The Hitachi 672/XD is a four color 11 by 17 (B size) plotter with superior accuracy and repeatability (.3mm). The 672 accepts HPGL 7475 commands and is both Centronics parallel and RS232C compatible. The 672 plots at a fast eight inches per second in axial direction and eleven inches at an angle of 45 degrees. The plotter also features a self contained digitizing function that allows data to be entered into your computer from printed graphs and blue prints. Four different color pens are supplied with the plotter but a wide variety of technical pens are available.

40 Megabyte Hard Disk Kit

Forty megabyte internal hard disk drive, controller and cables all for only \$397. The kit includes the 40 millisecond Miniscribe 3650 drive and a half slot Western Digital controller.

\$397

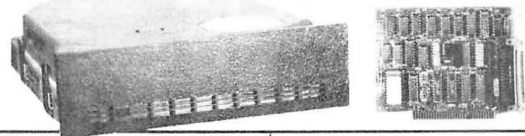

	One	Two	Ten
TEC501 1/2 height sgl. side	49	39	35
TANDON 101/4 full ht. 96 TPI.	99	89	79
FUJITSU 5 1/4" half height	65	63	57
MITSUBISHI new 501 half ht.	119	109	105
MITSUBISHI 504A AT comp.	149	139	135
TEAC FD55BV half height	89	85	79
TEAC FD55FV 96 TPI, half ht.	119	109	105
TEAC FD55GF for IBM AT	109	105	99
PANASONIC 455 Half Height	109	99	89
PANASONIC 475 1.2 Meg./96	119	115	109
Switching power supply			49
Dual enclosure for 5 1/4" drives			59

3 1/2" DISK DRIVES			
SONY MP-53W 720K/Byte	129	125	119
SONY MP-73W, 2 Meg.	159	149	call
TEAC 35FN 720 K/Byte	129	119	115
TEAC 35HN/30, 2 Meg.	159	149	145
5 1/4" form factor kit			20

8" DISK DRIVES			
QUME 842 double sided	189	179	175
QUME 841 single sided	119	109	99
SHUGART 851R dbl. sided	319	309	299
REMEX RFD4000 dbl. sided	189	179	165
OLIVETTI 851	189	179	165

Heath H/89 Computer
\$179



Hard to believe... but we found a stash of brand new Zenith/Heath Model H/89 computers. These computers feature the Zilog Z-80 CPU and operate under CP/M. The unit incorporates a 12 inch green screen, three serial ports and one 5 1/4" disk drive. Zenith's original price was \$1895. We have 350 units available for sale, while supplies last we are offering the H/89 at only \$179. Word processing and communication software included.

Five Inch Winchester Disk Drives		
Price does not include controller.	each	two+
SEAGATE 225 20 Meg. 1/2 Hi.	239	229
SEAGATE 238 30 Meg. RLL	259	249
SEAGATE 251/151 M. 28ms.	459	445
SEAGATE 4096 96 M. 35ms.	659	639
MINISCRIBE 8425 25 M. 65ms.	239	227
MINISCRIBE 3650 50M 61 ms.	419	399
MINISCRIBE 6085 90 meg.	795	779
MINISCRIBE 3053 25 ms. 1/2 ht.	459	439
FUJITSU 2242 55 M. 35ms.	1299	1229
FUJITSU 2243 86 M. 35ms.	1695	1619
RODIME RO-204E 53 Meg.	895	859
MAXTOR XT1140 140 Meg.	1595	1550
MAXTOR XT2190 192 Meg.	1919	1875
TOSHIBA MK56 70 M. 30ms.	1289	1229
CONTROL DATA WREN "V"	call	

Winchester Controllers for IBM/PC		
XEBEC 1220 with floppy controller	159	
DTC 5150XC	119	
OMTI 5527 RLL controller	99	
ADAPTEC 2070 RLL controller	99	
ADAPTEC 2372A 1/1 interleaf	159	
WESTERN DIGITAL WD/1002WX2	89	
WESTERN DIGITAL 1003WAH or WA2 139		
WESTERN DIGITAL 1007/WA2 ESDI	239	
● SCSI/SASI Winchester Controllers ●		
XEBEC 1410A 5 1/4" foot print	239	
WESTERN DIGITAL 1002-05E 5 1/4"	229	
OMTI 20L	89	
● Winchester Accessories ●		
Dual floppy enc. and powersupply	59	
Winchester enclosure and supply	139	
Switching power supply	49	



master charge
VISA
8:00 AM to 5:00 PM
Pacific Time

Every year since 1973, customers from virtually every nation in the free World have chosen California Digital for their data processing requirements. If its computer, California Digital has it... complete minisystem or just one microchip. California Digital offers over 10,000 unique computer products. Regardless of how specialized your data processing requirements... California Digital is your one stop shopping solution.

TECHNICAL & CALIFORNIA
(213) 217-0500
TOLL FREE ORDER LINE
(800) 421-5041

Telex • (213) 217-1951

3M

*FREE! DataSaver...
a \$13.95 diskette filer!!

DS-DD	Quantity Discounts Available min. 5 boxes	DS-HD
.69	5.25" 3M Diskettes	*1.15
1.47	3.50" 3M Diskettes	3.59
1.79	8.00" 3M Diskettes	2.05
.39	3M Highland Box Diskettes (min 10 bx)	
DC-1000	12.50	DC-300XLP 19.40
DC-2000	17.05	DC-600A 21.45
3M Mag. Tapes 2400' WTS (min 10 reels)		12.50
3M Mag. Tapes 1200' WTS (min 10 reels)		9.25

BASF

*FREE Plastic Library Box

SS-DD	Quantity Discounts Available	DS-HD
.53*	5.25" BASF Diskettes	.89
1.59	8.00" BASF Diskettes	1.79
DS-DD	3.50" BASF Diskettes in FREE Color-Coder a \$14.95 Value	DS-HD
1.34		3.69
.62	5.25" DS/DD BASF Diskettes with FREE BASF VCR Tape or Plastic Box	
.38	5.25" DS/DD BASF NoLogo Diskettes with Tyvek sleeves, labels & w/p.	

Verbatim & DataLife Plus

DS-DD	Quantity Discounts Available	DS-HD
.69	5.25" DataLife Diskettes	1.29
1.49	3.50" DataLife Diskettes	3.75
.85	5.25" DataLife Plus Diskettes with FREE! DISCUS Software	

maxell

*with FREE Game or Plastic Box

DS-DD	Quantity Discounts Available	DS-HD
.65*	5.25" Maxell R & D	*1.19
1.49	3.50" Maxell R & D	3.69
MAXELL DATA CARTRIDGES		
DC-600A	DC300XL/P	DC-2000
19.50	17.50	16.50

Nashua

MD-2D	MD-2HD	MF-2	MF-2HD
.46	.79	1.24	3.20
COLOR DISK	5.25" DSDD	5.25" DSHD	3.50" DSDD
.39	.82	1.14	
BULK DISK	5.25" DSDD	5.25" DSHD	3.50" DSDD
.29	.59	1.07	

RIBBONS STORAGE

— Please call for information —

TERMS: No surcharge on VISA, Mastercard or AMEX. COD only add \$3.00. Prepaid orders deduct 2% cash discount. PO's accepted from recognized institutions and corporations on Net 30. Bank draft, T/T or L/C acceptable.

Shipping: \$4/100 or fewer disks. Reduced shipping charges on larger quantities. Price quoted for case (100 disks) quantities less than a case add 5%. (Min order \$25.00)

WE BEAT ANY PRICE!

Toll Free Order Line: 1-800-523-9681
Information Line: 1-801-255-0080
TLX-9102404712 FAX-801-572-3327

DISKOTECH

DISKCO TECHNOLOGIES, INC.
213 Cottage Avenue
P.O. Box 1339 Sandy, Utah 84091

IEEE 488 Solutions

- Hardware & software interfaces for PC, AT, 386, PS/2, Macintosh, SUN, HP & DEC
- IEEE converters to SCSI, RS-232, RS-422, modem, Centronics, digital I/O & analog I/O
- IEEE extenders, expanders & buffers
- IEEE drivers for DOS, UNIX®, Lotus 1-2-3, Symphony & Quattro.

Call or send for your **FREE Technical Guide**
Demo disks and application notes available



(216) 439-4091
Telex: 65028240664 • Fax (216) 439-4093
IOtech, Inc. • 25971 Cannon Road
Cleveland, Ohio 44146

Circle 112 on Reader Service Card

DATA ACQUISITION

- ALL needs! ANY computer!**
- PC Software Included
 - Serial, Modem, & Bus
 - Stand Alone Ability
 - Laptop & Handheld
 - PC & MAC Cards
 - Inexpensive
 - OEM & VAR
 - RTU's



Call for FREE DEMO DISK!
Specialists in portable and battery backed up as well as PC compatible modular systems.

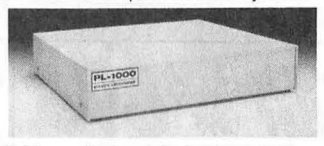

Call for applications info: (201) 299-1615
P.O. Box 246; Morris Plains, NJ 07950



Circle 83 on Reader Service Card

BIOS SOURCE CODE

The **The AT BiosKit** is a book with diskettes containing source code in C, plus utility programs to help you create a Bios. Now you can have a Bios with documentation for your own applications: modify boot-up, eliminate the keyboard, install security features, etc. Only \$199 complete. The **XT BiosKit** is only \$99, or get both BiosKits for \$279. The **Intel Wildcard Supplement** for the XT BiosKit is \$49.

— XT-AT HANDBOOK —

The **XT-AT Handbook** is full of hardware and software information in a shirt pocket size book. Over 70 pages covering 38 subjects, including connectors, I/O maps, controller programming, DOS and DEBUG commands, board dimensions, character codes, hard disk drive types, and much more. Only \$99.50 each qty 1-4, five or more, \$5 each.

Annabooks
12145 Alta Carmel Ct Suite 250-262
San Diego, California 92128
(619) 271-9526



Circle 15 on Reader Service Card

Z80 or HD64180

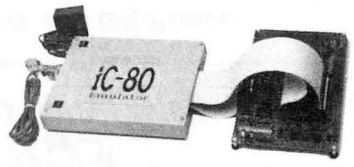

iC-80 In-Circuit Emulator

- Can be configured for Z80 or HD64180.
- C source code level debugging with our C compiler.
- Works with IBM-style PC.
- 64K overlay memory.
- Base price \$995.00. \$1340.00 including one probe and symbolic debug software.

Z-World, 1772 Picasso Ave, Davis, CA 95616

(916) 753-3722

Fax: (916) 753-5141.

In Germany: iSystem 08131/1687

Circle 255 on Reader Service Card

Okidata ML 82A and ML 83A Printers:

IBM EMULATION "PLUS"

Epson Compatibility/Letter Quality

PC-WRITER

ONLY \$99.00



plus shipping & sales tax (Calif. addresses)
Money back guarantee

- FULL EMULATION OF THE IBM PC GRAPHICS PRINTER
- LETTER QUALITY PRINTING
- ELITE CHARACTER PITCH
- SUBSCRIPTS/SUPERSCRIPTS
- DOT ADDRESSABLE GRAPHICS
- FRONT PANEL FEATURE SELECTION

To Order: (714) 261-0228
Dealer Information Available



RAINBOW TECHNOLOGIES, INC.

18011-A Mitchell So., Irvine, CA 92714
(714) 261-0228 Telex: 386078

Circle 197 on Reader Service Card

9-Track Tape Subsystem for the IBM PC/XT/AT



Now you can exchange data files between your IBM PC and any mainframe or mini-computer using IBM compatible 1600 or 6250 BPI 9-Track tape. System can also be used for disk backup. Transfer rate is up to 4 megabytes per minute on PCs and compatibles. Subsystems include 7" or 10 1/2" streaming tape drive, tape coupler card and DOS compatible software. For more information, call us today!



9621 Irontdale Ave., Chatsworth, CA 91311
Telephone: (818) 882-5822

Circle 190 on Reader Service Card

ACP's HOT SHEET

LATEST PRICES AND PRODUCTS!

MEMBER
MMC
MICROCOMPUTER
MARKETING COUNCIL
of the Direct Marketing Association, Inc.

SPECIAL BUY! HANDSCAN

by **saba**

469. List 799!

Don't confuse Handscan with other lowest scanners on the market...many deluxe features! Never before available at this special low price...order now!

Super Special! 512K Upgrade with Purchase... **99.**

799.

AMAX/Advanced 286/10 MHz BareBones

Includes 101-key keyboard, 1.2Mb floppy, floppy/HD controller card, 0K expands to 1 Meg.

Call for Custom Configurations...

IBM Blowout Sale !!!

If you missed the IBM Auction in Atlanta - WE WERE THERE - and we bought big! On this Monday 12/12 we start unloading 5 truckloads of IBM PC's, expansion boards, memory and over 6000 real IBM software packages...

- IBM XT/286 **1395.**
- IBM AT/339(OK) **2295.**
- IBM PC/3270 **1095.**
- IBM PC/XT268 **895.**
- PC Voice Comm Card **149.**
- AT Exp Card 0Kto2Mb **49.**
- Monochrome adaptor Color adaptor **39.**
- AT Prototype board .. **25.**
- Synchronous Comm adaptor **49.**
- 3270 Exp Card, 1Mb **599.**
- IBM Reporting Assnt **25.**
- IBM Writing Assnt ... **29.**
- IBM Filing Assnt **25.**
- IBM Fortran **call.**
- IBM Xenix **call.**
- IBM 3270 Emulator ... **25.**
- IBM 3101 Emulator ... **25.**
- IBM Education Series Software, choose from 49. 300 titles from **6.**
- Appointment **19.**
- Asset catalog **19.**
- Mailing Labels **19.**
- Data Edition **19.**
- IBM DOS 2.0/3.1 from 15.

ALL IBM SUPER VALUES... ALL PRICED TO SELL QUICK!

LOW COST COMPATIBLE CARDS

ACP Advanced Cards/IBM Monographics/HGA w/print port	55.	XT floppy controller, 1.44Mb	89.
Colorgraphics w/print port	55.	AT 3.0Mb w/Multi I/O, 0K	199.
SuperEGA Genoa compatible	149.	AT SuperMulti I/O/floppy	119.
SuperVGA, 1024 x 768	269.	PS/2 Multi I/O	99.
Diamond Multi I/O 25.6g.c/k/XT	139.	PS/2 Floppy controller 1.44Mb	89.
XT Six-Pak compatible/OK	89.	HP Laserjet 1Mb drum card	399.
XT 286 Accelerator card	269.	MOTHERBOARDS	
XT Multi I/O w/floppy controller	69.	XT Turbo w/BIOS, 8MHz	89.
XT dual floppy controller	29.	XT Turbo w/BIOS, 10MHz	99.
XT Serial I/O card	29.	AT 286 w/BIOS, 10MHz	279.
XT/AT Parallel I/O card	29.	AT Baby w/BIOS, 12MHz	299.
AT Serial I/O card	39.	AT 386 w/BIOS, 16MHz	1499.
XT/AT Game adapter port	29.	COMPACT DISC	
XT/AT EPROM programmer	149.	CFAX 4800 PC fax board	3 4 9.
		CHS 2000PI Hand Scanner	179.

FLOPPY DISC DRIVES

SONY 312/Micro Floppy 1.44Mb	139.	DD04D 360K Floppy black bezel	84.
55BV 360K Floppy/PC/XT/AT	89.	DD04E-G 360K Floppy AT gray	84.
TOSHIBA AMERICA FDD4403 31/2" Micro 720K	99.	DD08D-G 1.2Mb AT gray	110.
31/2" Micro 1.44Mb w/kit	139.	ADVANCED	
		360K Floppy-black bezel	69.
		1.2Mb Floppy-black bezel	89.
		3.5" 1.44Mb Floppy w/kit	99.
		3.5" 720K Floppy w/kit	79.

SPECIAL PURCHASE!!

85Mb Hard Drive Includes EDSI AT Controller... **749.** ACP's Special Year-End Sale!

20 Mb Hard Drive Kit **249.** LIMITED STOCK

20 Mb Hard Card **288.** At this low price, you can't afford not to buy one.

AST Research Your Choice... Advantage AT or Rampage AT **99.**

QUADRAM Silver Quad **89.** (Sixpak compatible)

- Liberty XT, EMS **89.**
- Quadprint Accelerator... **89.**

I/O MEMORY/GRAPHICS CARDS

AST Research		AboveBoard PS/286,512K,mod 30	475.
Xlormer/286, 512K, 10MHz	call.	8087 102, 80287-8	255.
Advantage 2/386,0K,EMS PS/2	399.	80287-1 PS/2	205.
Adv Prem AT/286/512K L1M 4.0	499.	8087-2	158.
Rampage/512K,EMS,PS/2	699.	80287-6	165.
Rampage AT,512K,L1M4,0,1e2Mb	389.	ORCHID Technology	
RampagePlus/MC,0K,mode50,60	399.	Tiny Turbo 286 - REDUCED!	299.
RampagePlus/286,0K,up to8Mb	399.	Designer 800 8-bit, EGA Card	269.
AST Sixpakplus, 0K	call.	ProDesigner 16-bit VEGA	329.
ATI Technologies		ProDesigner Plus 16-bit VEGA,512K	499.
EGA Wonder 800	289.	RAMQUEST 50/PS/2, 2Mb	699.
VGA VIP	299.	PARADISE	
VGA Wonder (1024x768)	499.	VGA Plus	289.
2400cint. Modem w/MNP-5	199.	VGA Plus 16	369.
GENOA		VGA Professional	369.
Super EGA/Hi-Res Plus	229.	Autoswitch 480 EGA card	199.
Super VGA/Hi-Res	339.	QUADRAM	
Super VGA	249.	Microdraft II buffer w/64K	269.
Superspectrum mono ICGA/HGA	189.	Quadprint XT accelerator	89.
INTEL		Liberty EMS XT card, 0K	89.
Inboard386PC to386/16MHz,1Mb	895.	Silver Quadcard, Sixpak comp.	89.
Inboard386/AT to386/16MHz	1095.	VIDEO 7	
Inboard386/AT install kits,ea.	185.	VGA Deluxe, EGA Card	219.
AboveBoard 2 Plus,0K,mode50,60	329.	VegaVGA, 8-bit VEGA card	329.
AboveBoard 286,512K,0S/PS/2	399.	Fastwrite VEGA, 16-bit VEGA card	419.
		VramVGA, VGA VEGA card	649.

NUMONICS SPECIAL PURCHASE!!

Cordless Mouse 99.95 Includes drivers, charger, receiver, T-mouse & PC Paint

Manager Mouse 59.95 Includes drivers, charger, receiver, T-mouse & PC Paint

INPUT DEVICES • MICE

Advanced PC Keyboards		LOGITECH	
5160 84key XT/ATswitchable	59.	Bus Mouse PC/XT/AT	95.
5161 101key XT/ATswitchable	79.	Serial Mouse PC/XT/AT	95.
CH Products		Serial Mouse PS/2	79.
Mach II Joystick-IBM	30.	MICROSOFT	
Gamecard III/IBM	44.	Bus Mouse w/PC Paintbrush	105.
KEYTRONICS		Serial Mouse w/PC Paintbrush	105.
KB5151 Deluxe IBM PC w/99 keys	169.	Serial PS/2 w/PC Paintbrush	109.
KB101 101 key/AT	110.	PC Mouse serial PC/XT/AT	98.
KB5153 keyboard w/touchpad	199.	PS/2 Mouse serial	98.
KRAFT		PC Mouse bus PC/XT/AT	98.
IBM PC/XT/AT Joystick/2 button	29.	SUMMAGRAPHICS	
IBM PC/XT/AT Joystick/3 button	34.	SummaSketch Plus/IBM	449.

Rated No. 1

Box of 10... **6.99** Qty. 5 7.50 each.

Polaroid® DataRescue™ IBM DS/DD Gray Disks

Backed by DATARESCUE...Polaroid will retrieve your data FREE if you lose it!

- 3.5" DS/DD 1Mb 16.50
- 3.5" HD 2Mb 39.95
- 5.25" HD 1.61Mb 14.99

HARD DISK DRIVES

MICROPOLIS		65Mb,ST272R, AT,(40ms)HH	549.
1333A/53Mb,Full ht.,30ms.	649.	38Mb,ST403B, AT,(40ms)FH	449.
1335/85Mb,Full ht.,30ms.	699.	42Mb,ST4051, AT,(40ms)FH	499.
MAXTOR		44Mb,ST4053, AT,(28ms)FH	499.
XT 1085/85Mb, MFM	849.	80Mb,ST4096, AT,(28ms)FH	699.
XT 1140/143Mb, MFM	1495.	21Mb,ST125, 3.5,(28ms)HH	329.
XT 4380/380Mb, ESDI	2995.	30Mb,ST138, 3.5,(38ms)HH	429.
PLUS Development		WESTERN DIGITAL	
Plus20 Hardcard, 20Mb,49ms.	549.	Filecard/PS30 PS/2 model 30	389.
Plus40 Hardcard, 40Mb,39ms.	699.	Filecard30	399.
SEAGATE		1003RAH Controller 1, 1interleave	199.
21Mb,ST225, AT,(65ms)HH	249.	1003RAH Controller RL/AT	167.
30Mb,ST238R(65ms)RL/AT/HH	299.	1003W42 Floppy/Hard/AT	149.
42Mb,ST251, AT,(40ms)HH	399.	1002-27K Controller RL/AT	99.
42Mb,ST251-1AT,(28ms)HH	450.	1002-WX1 Controller/XT	89.

IBM Floppy Disk Drive!!! Original DS/DD 360K Drives, 5-1/4" **59.95** Super Price! While Quantities Last

TAPE BACKUP/VIDEO

ALPHAMICRO		IRWIN	
VCR Videotape tax backup card	349.	1100 XT/AT 10Mb backup(int)	199.
IOMEGA		1200 AT 20Mb backup(int)	369.
Bernoulli 20Mb 51/4" internal	945.	145C AT 40Mb backup(int)	499.
Bernoulli 20Mb 51/4"external	1188.	TALLGRASS Technologies	
Tri-pak 20Mb cartridge 51/4"	189.	1020 XT 20Mb backup(int)	319.
Tri-pak 20Mb cartridge, 8"	255.	1040 AT 40Mb backup(int)	(see box)
PC3B Adapter card PC/XT/AT	189.	1040 XT 40Mb backup(int)	(see box)
PS4 Adapter/PS/2mod 50,60,80	299.		

Toshiba Laptops

The Complete Toshiba family of Laptops from ACP - L.A.'s #1 Source!

Toshiba T-1000 Laptop... **779.**

T-1200F...reg. \$2099...ACP 1395.

T-1200FB Special Price! call ACP!

T-1200H...reg. \$3499...ACP 2395.

T-1200HB Special Price! call ACP!

T-3100/20...reg. \$4699...ACP 2995.

T-3200...reg. \$5799...ACP 3995.

T-5100...reg. \$7499...ACP 4995.

PRINTERS

DICONICS/KODAK		HEWLETT PACKARD	
150P Portable printer(parallel)	339.	Laserjet Series II	call.
300P w/wide carriage(parallel)	539.	Deskjet w/laser quality	895.
EPSON		Scanjet flatbed scanner	call.
LX800 80column, 180cps	209.	TOSHIBA	
EX800 FX286c, FX86c, LQ850, LQ1050, LQ500, etc.	call.	P321SL, 24pin, 216cps	499.
ACP is your full line Epson dealer		P341SL, 24pin, 216cps	699.
		P351SX, (color add \$179)	1099.
		Pagelaser 12, High volume laser	call.

FREE CABLE with Purchase!

499. 321SL Sale!

CITIZEN ACP's *120d... 149. Sale! *180d... 189.

MODEMS

ADVANCED MODEMS		ConnectionCompressor 2400baud	249.
1200baud w/software(internal)	69.	2400B Modem2, /50z,60,70,80	319.
1200baud External w/software	89.	2400B Classic Modem2, XT/AT	269.
2400baud w/software(internal)	99.	MIGENT	
2400baud External w/software	139.	Pocket Modem 1200	sale 95.
HAYES		PROMETHEUS	
Smartmodem 2400B w/sw(int)	447.	2400G External	188.
Smartmodem 2400 External	447.	2400B2 w/software(internal)	149.
INTEL		1200B2 w/software(internal)	sale 89.
ConnectionCompressor w/sw(int)	799.		

MONITORS

AMDEK		NEC	
310A 12" amber TTL - REduced--88!		Multisynch II 13" TTL/Analog	595.
410A 12" amber green w/white	153.	Multisynch Plus 15" VGX/EGA	945.
1280 13" graphics(1280x800)	799.	Multisynch XL 201(1024x800)	2275.
Laser Drive CDROM w/Microsoft	899.	Monograph sys (1024x1024)	1555.
IBM MONITORS		SAMSUNG-IMTEC	
8503 12" Mono(640x480)	199.	12" amber TTL monochrome	88.
8512 14" Color analog	499.	14" amber flat screen TTL mono	198.
8513 12" EGA(640x480)	549.	14" white flat screen TTL mono	129.
8514 16" Hi-res(1024x768)	1295.	14" CGA/RGB Color	288.
		14" VGA Color	388.
		14" VGA Color	388.
MAGNAVOX		WYSE	
RGB Color display 80/CGA	288.	WY30 14" terminal	349.
EGA Color display	399.	WY50 14" terminal	419.
VGA Color display	499.	WY60 14" terminal ASCII	519.

ACP's Special Introductory Price... **995** New! from RAY-O-VAC® AT Replacement Battery

Direct replacement for AT/286/386 real-time clocks

Software Sale! IBM Writing Ass't, v2. 99... All popular software in stock... call!

Lotus 1-2-3 .325. Word Perfect258.

Ventura499. Excel299.

Multisynch Compatible **419. MULTISYNCH MONITOR** ...ACP's Sale Price!

for the FASTEST SERVICE order by phone...

Mail Orders: P.O. Box 17329 Irvine, CA 92713

Retail: 1310 E. Edinger, Santa Ana, CA 92705

Advanced Computer Products, Inc.

Authorized dealers for Hyundai • AST • Epson • Citizen • NEC • Okidata • Maxell • Seagate Magnavox • Sony • Toshiba • Sharp • HP • Intel • Microsoft • Ventura • Aldus • many more...

800-FONE ACP

800-366-3227 • 714-558-8813

Customer Service 714-558-1356

• \$25.00 Minimum MAIL ORDER

• No Surcharge for VISA or MasterCard

• All 50 state purchasing agreements available

• Pricing subject to change without notice

• Supply limited on certain items

• ACP Retail store pricing may vary. Not responsible for typos.

• Limited warranties and other conditions may apply

Call for Corporate VPA's...

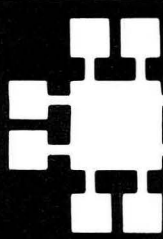

JDR Microdevices

MMC
MICROCOMPUTER
MARKETING COUNCIL
of the Direct Marketing Association, Inc.

• 30 DAY MONEY BACK GUARANTEE • 1 YEAR WARRANTY ON ALL PRODUCTS • TOLL-FREE TECHNICAL SUPPORT
• COMPLETE CUSTOMER SATISFACTION • SUPERIOR SERVICE • FRIENDLY, KNOWLEDGEABLE SALES STAFF

STATIC RAMS

PART	SIZE	SPEED	PRICE
2112	256x4	450ns	2.99
2114	1024x4	450ns	.99
2114L-2	1024x4	200ns	1.49
TC5516	2048x8	250ns	3.95
TMM2016-200	2048x8	200ns	3.25
TMM2016-150	2048x8	150ns	3.29
TMM2016-100	2048x8	100ns	4.29
HM6116-4	2048x8	200ns	4.95
HM6116-3	2048x8	150ns	5.95
HM6116-2	2048x8	120ns	6.45
HM6116L-4	2048x8	200ns	5.95
HM6116L-3	2048x8	150ns	6.45
HM6116L-2	2048x8	120ns	6.95
HM6264LP-15	8192x8	150ns	9.95
HM6264LP-12	8192x8	120ns	10.95
HM43256LP-15	32768x8	150ns	12.95
HM43256LP-12	32768x8	120ns	14.95
HM43256LP-10	32768x8	100ns	19.95

CALL TO CONFIRM CURRENT PRICES

DYNAMIC RAMS

PART	SIZE	SPEED	PRICE
4116-200	16384x1	200ns	.89
4116-150	16384x1	150ns	.99
MK4332	32768x1	200ns	6.95
4164-150	65536x1	150ns	2.89
4164-120	65536x1	120ns	3.19
4164-100	65536x1	100ns	3.95
TMS4164	65536x1	150ns	2.89
TMS4416	16384x4	150ns	8.95
41128-150	131072x1	150ns	5.95
TMS4464-15	65536x4	150ns	10.95
TMS4464-12	65536x4	120ns	11.95
41256-150	262144x1	150ns	12.45
41256-120	262144x1	120ns	12.95
41256-100	262144x1	100ns	13.45
41256-80	262144x1	80ns	13.95
HMS1256-100	262144x1	100ns	13.95
1 MB-120	1048576x1	120ns	34.95
1 MB-100	1048576x1	100ns	37.95

CALL TO CONFIRM CURRENT PRICES

EPROMS

PART	SIZE	SPEED	Vpp	PRICE
2708	1024x8	450ns	25V	4.95
2716	2048x8	450ns	25V	3.49
2716-1	2048x8	350ns	25V	3.95
2732	4096x8	450ns	25V	3.95
2732A	4096x8	250ns	21V	3.95
2764	8192x8	250ns	12.5V	4.95
2764-250*	8192x8	450ns	12.5V	3.49
2764-200	8192x8	200ns	12.5V	4.25
MCM68766	8192x8	350ns	21V	15.95
27128	16384x8	250ns	12.5V	4.95
27128A-200	16384x8	200ns	12.5V	5.95
27C256	32768x8	250ns	12.5V	7.95
27256	32768x8	200ns	12.5V	5.95
27256-200	32768x8	200ns	12.5V	7.95
27512	65536x8	250ns	12.5V	11.95
27C512	65536x8	250ns	12.5V	12.95
27C101-20	131072x8	200ns	12.5V	34.95

CALL TO CONFIRM CURRENT PRICES

CO-PROCESSORS

8087	5 MHz	99.95
8087-2	8 MHz	139.95
8087-1	10 MHz	194.95
80287	6 MHz	159.95
80287-8	8 MHz	229.95
80287-10	10 MHz	289.95
80387-16	16 MHz	449.95
80387-20	20 MHz	599.95
80387-25	25 MHz	699.95



intel
5
YEAR
WARRANTY

INCLUDES MANUAL & SOFTWARE GUIDE

CALL OUR WHOLESALE DEPT.
FOR VOLUME QUOTES

HIGH-TECH SPOTLIGHT

CMOS PROGRAMMABLE INTERVAL TIMER

RUNS COOLER, FASTER AND USES LESS POWER!
■ 3 INDEPENDENT 16-BIT COUNTERS ■ 24 PIN DIP
■ COUNTS BINARY OR BCD ■ SINGLE +5 V SUPPLY
■ DC TO 2 MHZ ■ LOW POWER CMOS
82C53-5 \$3.95

V-20 SERIES

SPEED UP YOUR PC BY 10% TO 40%!
■ HIGH SPEED ADDRESS CALCULATION IN HARDWARE
■ PIN COMPATIBLE WITH 8088 ■ LOW POWER CMOS
■ SUPERSET OF 8088 INSTRUCTION SET
V20* 5 MHz 8.95 V20* 8 MHz 10.95
V20* 10 MHz 12.95 V30 8 MHz 13.95

SIMMS SINGLE IN-LINE MEMORY MODULES

41256A8B-15	256K x 8-BIT MAC COMPATIBLE	150ns	\$89.00
41256A8B-12	256K x 8-BIT MAC COMPATIBLE	120ns	99.00
41256A8B-10	256K x 8-BIT MAC COMPATIBLE	100ns	129.00
41256A9B-15	256K x 9-BIT PC COMPATIBLE	150ns	\$119.00
41256A9B-12	256K x 9-BIT PC COMPATIBLE	120ns	129.00
41256A9B-10	256K x 9-BIT PC COMPATIBLE	100ns	139.00
41256A9B-80	256K x 9-BIT PC COMPATIBLE	80ns	159.00
42100A9B-10	1 MB x 9-BIT PC COMPATIBLE	100ns	529.00
42100A9B-80	1 MB x 9-BIT PC COMPATIBLE	80ns	599.00

PALS

16L8	\$2.95	20R4	\$4.95
16R8	2.95	20R6	4.95
16R6	2.95	20R8	4.95
16R4	2.95	20X8	4.95
20L8	4.95		

STARTER KIT

EASY TO USE PAL PROGRAMMING KIT.
PROGRAMS ALL THE PAL DEVICES AT LEFT.
MCT-PAL-SOFT 99.95

30 DAY MONEY-BACK GUARANTEE
TOLL-FREE TECHNICAL SUPPORT

74LS00 TTL LOGIC

74LS00	.16	74LS112	.29	74LS241	.69
74LS01	.18	74LS122	.45	74LS242	.69
74LS02	.17	74LS123	.49	74LS243	.69
74LS03	.18	74LS124	2.75	74LS244	.69
74LS04	.16	74LS125	.39	74LS245	.79
74LS05	.18	74LS126	.39	74LS251	.49
74LS06	.18	74LS132	.39	74LS253	.49
74LS09	.18	74LS133	.49	74LS257	.39
74LS10	.16	74LS136	.39	74LS258	.49
74LS11	.22	74LS138	.39	74LS259	1.29
74LS12	.22	74LS139	.39	74LS260	.49
74LS13	.26	74LS145	.99	74LS266	.39
74LS14	.39	74LS147	.99	74LS273	.79
74LS15	.26	74LS148	.99	74LS279	.39
74LS20	.17	74LS151	.39	74LS280	1.98
74LS21	.22	74LS153	.39	74LS283	.59
74LS22	.22	74LS154	1.49	74LS290	.89
74LS27	.23	74LS155	.59	74LS293	.89
74LS28	.26	74LS156	.49	74LS299	1.49
74LS30	.17	74LS157	.35	74LS322	3.95
74LS32	.18	74LS158	.29	74LS323	2.49
74LS33	.28	74LS160	.29	74LS365	.39
74LS37	.26	74LS161	.39	74LS367	.39
74LS38	.26	74LS162	.49	74LS368	.39
74LS42	.39	74LS163	.39	74LS373	.79
74LS47	.75	74LS164	.49	74LS374	.79
74LS48	.85	74LS165	.65	74LS375	.95
74LS51	.17	74LS166	.95	74LS377	.79
74LS73	.29	74LS169	.95	74LS390	1.19
74LS74	.24	74LS173	.49	74LS393	.79
74LS75	.29	74LS174	.39	74LS541	1.49
74LS76	.29	74LS175	.39	74LS624	1.95
74LS83	.49	74LS191	.49	74LS640	.99
74LS85	.49	74LS192	.69	74LS645	.99
74LS86	.22	74LS193	.69	74LS670	.89
74LS90	.39	74LS194	.69	74LS682	3.40
74LS92	.49	74LS195	.69	74LS688	2.45
74LS93	.39	74LS196	.59	74LS689	2.95
74LS95	.49	74LS197	.55	25LS2521	2.80
74LS107	.34	74LS221	.59	26LS31	1.95
74LS109	.36	74LS240	.69	26LS32	1.95

LINEAR COMPONENTS

TL071	.69	LM380	.89	XR2206	3.95
TL072	1.09	LM383	1.95	XR2211	2.95
TL074	1.95	LM386	.89	LM2917	1.95
TL081	.59	LM393	.45	CA3046	.89
TL082	.99	LM394H	5.95	CA3146	.89
TL084	1.49	LM399H	5.95	MC3373	1.29
LM301	.34	TL494	4.20	MC3470	1.95
LM309K	1.25	TL497	3.25	MC3480	8.95
LM310	1.75	NE555	.29	MC3487	2.95
LM311	.59	NE556	.49	LM3900	.49
LM311H	.89	NE558	.79	LM3909	.98
LM312H	3.49	NE564	1.95	LM3911	2.25
LM312H	1.75	LM565	.95	LM3914	1.89
LM317T	.69	LM566	1.49	LM3915	1.89
LM318	1.49	LM567	.79	MC4024	3.49
LM319	1.25	NE570	2.95	MC4044	3.99
LM323K	3.49	NE590	2.50	RC4136	1.25
LM324	.34	NE592	.98	RC4558	.69
LM331	3.95	LM723	.49	LM1360	1.49
LM334	1.19	LM733	.98	75107	1.49
LM335	1.79	LM741	.29	75108	1.49
LM336	1.75	LM747	.69	75110	1.95
LM338K	4.49	MC1330	1.69	75150	1.95
LM339	.59	MC1350	1.19	75154	1.95
LF347	2.19	LM1458	.35	75188	1.25
LF353	.59	LM1488	.49	75189	1.25
LF356	.99	LM1489	.49	75451	.39
LF357	.99	LM1496	.85	75452	.39
LM358	.59	ULN2003	.79	75477	1.29

HIGH SPEED CMOS LOGIC

74HC00	.21	74HC244	.85	74HCT138	.35
74HC04	.25	74HC245	.85	74HCT139	.55
74HC08	.25	74HC273	.69	74HCT157	.59
74HC14	.35	74HC367	.69	74HCT161	.79
74HC32	.35	74HC373	.69	74HCT240	.89
74HC74	.35	74HC390	.79	74HCT244	.89
74HC138	.45	74HC374	.69	74HCT245	.99
74HC139	.45	74HC4040	.89	74HCT273	.99
74HC154	1.09	74HCT00	.25	74HCT373	.99
74HC157	.55	74HCT04	.27	74HCT374	.99
74HC161	.65	74HCT08	.25	74HCT393	.99
74HC164	.65	74HCT32	.27	74HCT4040	.99
74HC175	.59	74HCT74	.45	74HCT4060	1.49

STANDARD CMOS LOGIC

4001	.19	4028	.65	4069	.19
4011	.19	4040	.69	4070	.29
4013	.35	4042	.59	4081	.22
4015	.29	4044	.69	4093	.49
4016	.29	4046	.69	14411	9.95
4017	.49	4047	.69	14433	14.95
4018	.69	4049	.29	14497	6.95
4020	.59	4050	.29	4503	4.95
4021	.69	4051	.69	4511	.69
4023	.25	4052	.69	4518	.85
4024	.49	4053	.69	4528	.79
4025	.25	4060	.69	4538	.95
4027	.39	4066	.29	4702	9.95

7400 SERIES LOGIC

7400	.19	74121	.29	74F240	1.29
7402	.19	74123	.49	74S00	.29
7404	.19	74125	.45	74S02	.29
7406	.29	74150	1.35	74S04	.29
7407	.29	74151	.55	74S08	.35
7408	.24	74153	.55	74S10	.29
7410	.19	74154	1.49	74S12	.35
7411	.25	74157	.55	74S14	.49
7414	.49	74161	.69	74S18	.35
7416	.25	74164	.85	74S124	2.75
7417	.25	74166	1.00	74S138	.79
7420	.19	74175	.89	74S153	.79
7430	.19	74367	.65	74S157	.79
7432	.29			74S158	.95
7438	.29			74S163	1.29
7442	.49	74F00	.35	74S175	.79
7445	.69	74F02	.35	74S195	1.49
7447					

CRYSTALS

32.768 KHz	.95
1.0 MHz	2.95
1.8432	2.95
2.0	1.95
2.4576	1.95
3.579545	1.95
4.0	1.95
5.0	1.95
5.0688	1.95
6.0	1.95
6.144	1.95
8.0	1.95
10.0	1.95
10.738635	1.95
12.0	1.95
14.31818	1.95
16.0	1.95
18.0	1.95
18.432	1.95
20.0	1.95
22.1184	1.95

OSCILLATORS

1.0MHz	5.95
1.8432	5.95
2.0	5.95
2.4576	5.95
2.5	5.95
4.0	4.95
5.0	4.95
5.0688	4.95
6.0	4.95
6.144	4.95
8.0	4.95
10.0	4.95
12.0	4.95
14.31818	1.95
15.0	1.95
16.0	4.95
18.432	4.95
20.0	4.95
24.0	4.95

MISC.

ADC0804	2.99
ADC0809	3.85
DAC0800	3.29
DAC0808	1.95
DC1022	5.95
MC1408L8	1.95
8T28	1.29
8T97	.59
DP8304	2.29
9334	1.75
9368	2.85
9602	.69
ULN2003	.79
MAX232	7.95
MC3470	1.95
MC3487	2.95
AY5-3600	
PRO	11.95

CLOCK CIRCUITS

MC146818	5.95
MM58167	9.95
MM58174	9.95
MM5832	2.95

VOLTAGE REGULATORS

7805T	.49	7812K	1.39
7808T	.49	7905K	1.69
7812T	.49	7912K	1.49
7815T	.49	78L05	.49
7905T	.59	78L12	.49
7908T	.59	79L05	.69
7912T	.59	79L12	1.49
7915T	.59	LM323K	3.49
7805K	1.59	LM338K	4.49

POWER SUPPLIES

APPLE TYPE SUPPLY
 ■ WITH APPLE CONNECTOR
 ■ +5V @ 6A, +12V @ 3A,
 -5V @ 1A, -12V @ 1A
PS-A \$49.95

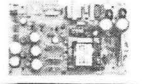

FLOPPY DRIVE SUPPLY
 ■ +5V @ 2.5A, +12V @ 2A,
 -12V @ 1A
 ■ +5V @ 5A, IF +12 NOT USED
PS-ASTEC \$24.95



36 WATT POWER SUPPLY
 ■ +5V @ 2.5A, +12V @ 1.5A
 ■ 3 PIN INPUT, 6 PIN OUTPUT
 ■ SELECTABLE 110V-220V
PS-3045 \$12.95



144 WATT MICRO SUPPLY
 ■ +5V @ 18A, +12V @ 4A,
 -12V @ 500MA
PS-1554 \$29.95

WIREWAP**PROTOTYPE CARDS**

FR-4 EPOXY GLASS LAMINATE WITH GOLD PLATED EDGE CARD FINGERS AND SILK SCREENED LEGENDS.



FOR XT
 JDR-PR1 WITH +5V AND GROUND PLANE 27.95
 JDR-PR2 AS ABOVE WITH I/O DECODING LAYOUT 29.95

FOR PS/2
 JDR-PR32 32 BIT PROTOTYPE CARD 69.95
 JDR-PR16 16 BIT WITH I/O DECODING LAYOUT 49.95
 JDR-PR16PK PARTS KIT FOR JDR-PR16 ABOVE 15.95
 JDR-PR16V 16 BIT FOR VIDEO APPLICATIONS 39.95

FOR AT
 JDR-PR10 16BIT WITH I/O DECODING LAYOUT 34.95
 JDR-PR10PK PARTS KIT FOR JDR-PR10 ABOVE 12.95

EXTENDER CARDS

FOR PROTOTYPE DEBUGGING, TESTING AND TROUBLESHOOTING.

EXT-8088 XT COMPATIBLE 29.95
 EXT-80286 AT COMPATIBLE 39.95
 EXT-16 MICROCHANNEL 16 BIT 69.95
 EXT-32 MICROCHANNEL 32-BIT 99.95

NEW LOW PRICES! SOLDERLESS BREADBOARDS

WBU-204-3 1360 TIE PTS 12.95
 WBU-204 1660 TIE PTS 19.95
 WBU-206 2390 TIE PTS 24.95
 WBU-208 3220 TIE PTS 34.95

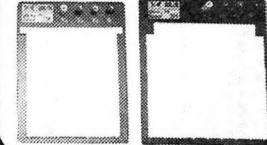
**PC SOLDERLESS BREADBOARDS**

■ 62 CLEARLY LABELLED BUS LINES
 ■ ACCEPTS UP TO 24 14-PIN ICs
 ■ 1940 TIE POINTS ■ EXTERNAL FEMALE DB25 D-SUB CONNECTOR UP-604 \$49.95

GENDER CHANGERS

GENDER-FF FEMALE-FEMALE 7.95
 GENDER-MM MALE-MALE 7.95
 GENDER-MF MALE-FEMALE 7.95
 GENDER-NM NULL MODEM 8.95
 GENDER-JB JUMPER BOX 8.95
 GENDER-MT MINITESTER 14.95
 GENDER-VGA DB9-DB15 19.95
 GENDER-9-25 DB9-DB25 4.95

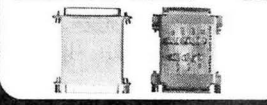
**"SNAPABLE" HEADERS**

SNAP APART TO MAKE ANY SIZE HEADER, ALL WITH .1" CENTERS

1x40 STRAIGHT LEAD .99
 1x40 RIGHT ANGLE LEAD .49
 2x40 STRAIGHT LEAD 2.49
 2x40 RIGHT ANGLE LEAD 2.99

EPROM ERASERS

SPECTRONICS CORPORATION

Model	Timer	# of Chips	Intensity (uW/Cm ²)	Unit Cost
PE-140	NO	9	8,000	\$89
PE-140T	YES	9	8,000	\$139
PE-240T	YES	12	9,600	\$189



DATASE II \$39.95
 ■ SHIRT POCKET SIZE!
 ■ ERASES MOST EPROMS/EPLDs IN 3 MINUTES
 ■ ALL SIZES UP TO 4 AT A TIME
DATASE II

**LITHIUM BATTERY**

LONG-LASTING 6 VOLT BATTERY FOR 286 AND 386 PCS - MOUNTS JUST ABOUT ANYWHERE!

■ MOTHERBOARD CONNECTOR
 ■ ADHESIVE VELCRO MOUNTING STRIP
LITHIUM 6.8V 11.95

SHORTING BLOCKS

5/1.00

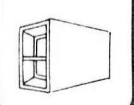
**COIN TYPE BATTERY**

LITHIUM-3V 1.95



HOLDER 3V-MHW 1.49

RS-232 BREAKOUT BOX

FOR TROUBLESHOOTING SERIAL COMMUNICATIONS

■ OPEN/CLOSE INDIVIDUAL CIRCUITS
 ■ 20 JUMPERS CROSS-CONNECT ANY 2 CIRCUITS
 ■ 10 LEDS SHOW CIRCUIT ACTIVITY
GENDER-BO 34.95

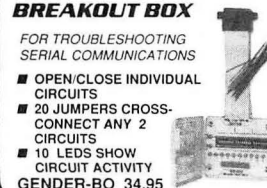
**DISK CONTROLLERS**

1771	4.95
1791	9.95
1793	9.95
1795	12.95
1797	12.95
2791	19.95
2793	19.95
2797	29.95
8272	4.39
UPD765	4.39
MB8876	12.95
MB8877	12.95
1691	6.95
2143	6.95

INTERSIL

ICL7107	10.95
ICL7660	1.99
ICL8038	3.85
ICM7207A	5.95
ICM7208	15.95

UARTS

AY5-1013	3.95
AY3-1015	4.95
TR1602	3.95
2651	4.95
IM6402	3.95
IM6403	9.95
INS8250	6.95

BYPASS CAPACITORS

.01UF CERAMIC DISC	100/5.00
.01UF-MONO MONOLITHIC	100/10.00
.1UF CERAMIC DISC	100/6.50
.1UF-MONO MONOLITHIC	100/12.50

BIT RATE GENERATORS

MC1441	19.95	COM5016	16.95
BR1941	4.95	COM8116	8.95
4702	9.95	MMS307	4.95

SOLDER STATION

UL APPROVED

- HEAT SETTING ADJUSTS
- TIP TEMPERATURE READOUT
- REPLACEMENT TIPS AVAILABLE @ \$2.95

168-2C

\$59.95



FULL 1 YEAR WARRANTY ON EVERY PRODUCT!

IDC CONNECTORS/RIBBON CABLE

DESCRIPTION	ORDER BY	CONTACTS					
		10	20	26	34	40	50
SOLDER HEADER	IDHxxS	.82	1.29	1.68	2.20	2.58	3.24
RIGHT ANGLE SOLDER HEADER	IDHxxSR	.85	1.35	1.76	2.31	2.72	3.39
WIREWAP HEADER	IDHxxW	1.86	2.98	3.84	4.50	5.28	6.63
RIGHT ANGLE WIREWAP HEADER	IDHxxWR	2.05	3.28	4.22	4.45	4.80	7.30
RIBBON HEADER SOCKET	IDSxx	.63	.89	.95	1.29	1.49	1.69
RIBBON HEADER	IDMxx	--	5.50	6.25	7.00	7.50	8.50
RIBBON EDGE CARD	IDExx	.85	1.25	1.35	1.75	2.05	2.45
10' PLASTIC RIBBON CABLE	RCxx	1.60	3.20	4.10	5.40	6.40	7.50

FOR ORDERING INSTRUCTIONS, SEE D-SUBMINIATURE CONNECTORS BELOW

D-SUBMINIATURE CONNECTORS

DESCRIPTION	ORDER BY	CONTACTS						
		9	15	19	25	37	50	
SOLDER CUP	MALE	DBxxP	.45	.59	.69	.69	1.35	1.85
	FEMALE	DBxxS	.49	.69	.75	.75	1.39	2.29
RIGHT ANGLE	MALE	DBxxPR	.49	.69	--	.79	2.27	--
	FEMALE	DBxxSR	.55	.75	--	.85	2.49	--
PC SOLDER	MALE	DBxxPWW	1.69	2.56	--	3.89	5.60	--
	FEMALE	DBxxSPP	2.76	4.27	--	6.84	9.95	--
WIREWAP	MALE	IDBxxS	1.39	1.99	--	2.25	4.25	--
	FEMALE	IDBxxSW	1.45	2.05	--	2.35	4.49	--
IDC RIBBON CABLE	MALE	IDBxxS	1.05	1.15	1.25	1.25	--	--
	FEMALE	IDBxxSW	1.05	1.15	1.25	1.25	--	--
HOODS	METAL	MHOODxx	.39	.39	--	.39	.69	.75
	PLASTIC	HOODxx	.39	.39	--	.39	.69	.75

ORDERING INSTRUCTIONS:
 INSERT THE NUMBER OF CONTACTS IN THE POSITION MARKED "xx" OF THE "ORDER BY" PART NUMBER LISTED. EXAMPLE : A 15 PIN RIGHT ANGLE MALE PC SOLDER WOULD BE DB15PR
MOUNTING HARDWARE 5¢

IC SOCKETS/DIP CONNECTORS

DESCRIPTION	ORDER BY	CONTACTS								
		8	14	16	18	20	22	24	28	40
SOLDERTAIL SOCKETS	xxST	.11	.11	.12	.15	.18	.15	.20	.22	.30
WIREWAP SOCKETS	xxWW	.59	.69	.69	.99	1.09	1.39	1.49	1.69	1.99
ZIF SOCKETS	ZIFxx	--	4.95	4.95	--	5.95	--	5.95	6.95	9.95
TOOLED SOCKETS	AUGATxxST	.62	.79	.89	1.09	1.29	1.39	1.49	1.69	2.49
TOOLED WW SOCKETS	AUGATxxWW	1.30	1.80	2.10	2.40	2.50	2.90	3.15	3.70	5.40
COMPONENT CARRIERS	ICCxx	.49	.59	.69	.99	.99	.99	.99	1.09	1.49
DIP PLUGS (IDC)	IDPxx	.95	.49	.59	1.29	1.49	--	.85	1.49	1.59

FOR ORDERING INSTRUCTIONS SEE D-SUBMINIATURE CONNECTORS ABOVE



JDR MICRODEVICES, 110 KNOWLES DRIVE, LOS GATOS, CA 95030
 LOCAL (408) 866-6200 FAX (408) 378-8927 TELEX 171-110



RETAIL STORE: 1256 SOUTH BASCOM AVE., SAN JOSE, CA (408) 947-8881
 HOURS: M-F 9-7 SAT. 9-5 SUN. 12-4



COPYRIGHT 1989 JDR MICRODEVICES

ORDER TOLL FREE 800-538-5000

Terms: Minimum order \$10. For shipping and handling include \$3.50 for ground and \$4.50 air. Orders over 1 lb and foreign orders may require additional shipping charges—please contact the sales department for the amount. CA residents must include applicable sales tax. Prices subject to change without notice. We are not responsible for typographical errors. We reserve the right to limit quantities and to substitute manufacturer. All merchandise subject to prior sales. A full copy of our terms is available upon request. Items pictured may only be representative.

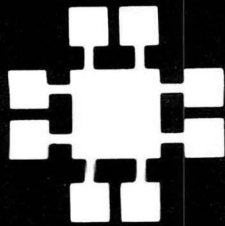

JDR Microdevices®

MMC
MICROCOMPUTER
MARKETING COUNCIL
of the Direct Marketing Association, Inc.

• 30 DAY MONEY BACK GUARANTEE • 1 YEAR WARRANTY ON ALL PRODUCTS • TOLL-FREE TECHNICAL SUPPORT
• COMPLETE CUSTOMER SATISFACTION • SUPERIOR SERVICE • FRIENDLY, KNOWLEDGEABLE SALES STAFF

PROMETHEUS 2400 BAUD MODEM



\$129.95

INTERNAL 2400 BAUD

- AUTO DIAL/ANSWER
 - SELF TEST ON POWER-UP
 - FULL OR HALF DUPLEX
 - TOUCHTONE OR PULSE DIALING
 - HAYES & BELL SYSTEMS COMPATIBLE
 - MIRROR II COMMUNICATIONS SOFTWARE INCLUDED
- PRO-24I 1200 BAUD 1/2 CARD **\$129.95**
PRO-12I 1200 BAUD 1/2 CARD **\$69.95**
PRO-24M 2400 BAUD FOR PS/2 **\$249.95**

EXTERNAL 2400 BAUD

- 2400/1200/300 HAYES COMPATIBLE
 - 8 EASY-TO-READ STATUS LED'S
 - CALL PROGRESS MONITORING & ADJUSTABLE VOLUME
 - 2ND PHONE JACK FOR VOICE COMMUNICATIONS
 - REQUIRES SERIAL PORT & CABLE (OPTIONAL)
- PRO-24E **\$169.95**
PRO-12E 1200 BAUD EXTERNAL **\$99.95**

APPLE/MACINTOSH MODEMS

- MACINTOSH 2400 BAUD EXTERNAL AS ABOVE WITH CABLE AND PROCOM-M SOFTWARE.
- PRO-24EM **\$199.95**
PRO-24A APPLE II 2400 BAUD MODEM **\$179.95**
PRO-12A APPLE II 1200 BAUD MODEM **\$139.95**

DFI HANDY SCANNER 400 DPI **\$249.95**

- ALL HANDY SCANNERS ARE NOT THE SAME!
- INSTANTLY SCANS UP TO 4" WIDE IMAGES
 - 100, 200, 300, 400 DPI BOTH DIRECTIONS
 - B&W AND 3 HALF-TONE MODES
 - 32 LEVELS OF GRAY SCALE
 - HERCULES, CGA AND EGA COMPATIBLE
 - INCLUDES HALO DPE AND IMAGE EDITOR SOFTWARE HS-3000



LOGITECH HIREZ MOUSE

\$99.95



HIGH RESOLUTION BUS MOUSE FOR BETTER RESPONSE AND LESS HAND MOVEMENT, IDEAL FOR CAD WORK

- 320 DPI
- INCLUDES DRIVER, TEXT EDITOR & POP-UP MENUS
- NO PAD, POWER SUPPLY OR PORT REQUIRED

LOGITECH 3-BUTTON MOUSE

- PC MAGAZINE EDITORS CHOICE! ALL MODELS HAVE SERIAL SUPPORT (COM1/COM2), 200 D.P.I. RESOLUTION, LOTUS 1-2-3 SHELL, SELF-INSTALLING SOFTWARE AND "POINT EDITOR"
- LMOUSE **\$79.95**
LMOUSE-P SERIAL MOUSE W/LOGIPAINT **\$99.95**
LMOUSE-BP BUS MOUSE W/LOGIPAINT **\$99.95**
LMOUSE-BPBL BUS MOUSE W/PUBLISHER PKG **\$139.95**
LMOUSE-BPC BUS MOUSE W/LOGIPAINT/CAD **\$149.95**

VGA COMPATIBLE PACKAGE **\$649**

- 800 X 560 MAXIMUM RESOLUTION
 - 640 X 480 IN 16 COLORS
 - 320 X 200 IN 256 COLORS
 - IBM STYLE ANALOG MONITOR
 - FULLY VGA, EGA, CGA, HERCULES & MONOCHROME COMPATIBLE
- VGA-PKG

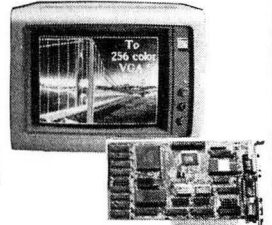

NEC MULTISYNC II **\$599.95**

- AUTO FREQ ADJUSTMENT
- RESOLUTION AS HIGH AS 800 X 560
- TEXT MODE & TEXT COLOR
- INCL. ADAPTOR NEC-MULTI

JDR MULTI **\$499.95**

- FULL FEATURED MULTISCAN MONITOR WITH UNLIMITED COLORS
- HIGH RESOLUTION, 14" NON-GLARE DISPLAY
- AUTO SWITCHING
- TTL/ANALOG VIDEO INPUT

RELISYS EGA **\$399.95**

- 800X560 MAXIMUM RESOLUTION
- 31 MM DOT PITCH
- 14" BLACK MATRIX SCREEN
- 16 COLORS SWIVEL BASE EGA-MONITOR

EGA SPECIAL - SAVE \$60!

BUY THE RELISYS EGA AND THE MCT EGA CARD TOGETHER AND SAVE \$60.00 **JUST \$489.00**

RGB MONITOR **\$279.95**

- COLOR/GREEN/AMBER SWITCH
- .41MM DOT PITCH
- 640 X 240 RESOLUTION
- 14" NON-GLARE SCREEN
- TILT AND SWIVEL BASE

RGB-MONITOR

FLAT SCREEN **\$139.95**

- LOW DISTORTION 14" GLARE-RESISTANT AMBER SCREEN
- 720 X 350 MAXIMUM RESOLUTION
- IBM COMPATIBLE TTL INPUT
- SWIVEL BASE

GM-1488 **MONO-SAMSUNG WITH 12" SCREEN \$129.95**

TILT & SWIVEL MONITOR STANDS

- MS-100 **\$12.95**
MS-200 5 OUTLETS AND SURGE SUPPRESSOR **\$39.95**

UPRIGHT CASE **\$299.95**

SLEEK UPRIGHT DESIGN SAVES SPACE, ADDS STYLE!

- ACCOMMODATES ALL SIZES OF MOTHERBOARDS
 - 250 W POWER SUPPLY INCLUDED
 - MOUNTS FOR 3 FLOPPY & 4 HARD DRIVES
 - TURBO & RESET SWITCH
 - SPEED DISPLAY, POWER & DISK LED'S
 - INCL. MOUNTING HARDWARE, FACEPLATES & SPEAKER
- CASE-100**
- CASE-FLIP FOR 8088 MOTHERBOARDS **\$34.95**
CASE-SLIDE FOR 8088 MOTHERBOARDS **\$39.95**
CASE-70 FOR 286 MOTHERBOARDS **\$89.95**
CASE-50 FOR 8088 OR 286 BOARDS **\$59.95**
CASE-JR MINI-286 W/POWER SUPPLY **\$149.95**

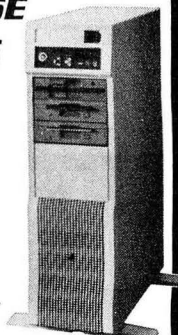

POWER SUPPLIES

- ALL OUR POWER SUPPLIES ARE UL APPROVED, 110/220V.
- PS-135 IBM XT COMPATIBLE, 135 WATTS **\$59.95**
PS-150 IBM XT COMPATIBLE, 150 WATTS **\$69.95**
PS-200 IBM AT COMPATIBLE, 200 WATTS **\$89.95**

POCKET MODEM **\$99.95**



- YOU'LL NEVER BE FAR FROM YOUR DATA WITH THIS 6 OUNCE HAND-HELD POCKET MODEM
- 1200/300 BAUD
 - BATTERY & AC POWER
 - SERIAL INTERFACE (DB25)
 - 4 STATUS INDICATORS
- GVC-12P **\$49.95**
GVC-24P 2400 BAUD VERSION **\$249.95**

24-HR. ON-LINE ORDERING!
(408) 374-2171
JDR'S ELECTRONIC BULLETIN BOARD OFFERS TECHNICAL SUPPORT, CONFERENCING AND MORE

DATA SWITCH BOXES

TYPE	# OF POS.	PARALLEL	SERIAL	PRICE
PUSHBUTTON	2-WAY	AB-P	AB-5	39.95
ROTARY	2-WAY	RSP-2	RSS-2	24.95
ROTARY	3-WAY	RSP-3	RSS-3	27.95
ROTARY	4-WAY	RSP-4	RSS-4	29.95

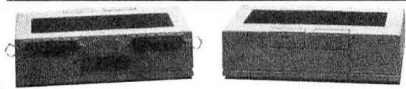

MOLDED COMPUTER CABLES

- HIGH QUALITY GOLD-PLATED CONTACTS; CABLE AND CONNECTORS ARE 100% SHIELDED. MOLDED ASSEMBLY.
- CBL-PRINTER PC PRINTER CABLE **\$9.95**
CBL-PRINTER-25 AS ABOVE - 25 FOOT **\$15.95**
CBL-PRINTER-RA RIGHT ANGLE PRINTER **\$15.95**
CBL-DB25-MM DB25 MALE TO DB25 MALE **\$9.95**
CBL-DB25-MF DB25 MALE TO DB25 FEMALE **\$9.95**
CBL-9-SERIAL 9 PIN TO 25 PIN SERIAL **\$6.95**
CBL-KBD-EXT KEYBOARD EXTENSION **\$7.95**
CBL-CNT-MM 36 PIN CENTRONICS-MM **\$14.95**
CBL-HD-20 20 PIN HARD DISK CABLE **\$3.95**
CBL-HD-34 34 PIN HARD DISK CABLE **\$4.95**
CBL-HD-34D 34 PIN DUAL HARD DISK **\$6.95**
CBL-FDC-EXT 37 PIN EXTERNAL FLOPPY **\$9.95**
CBL-MNT-9 9 PIN MONITOR EXTENSION **\$6.95**
CBL-MODEM DB25 TO DB25 FEMALE **\$7.95**



KEYBOARDS

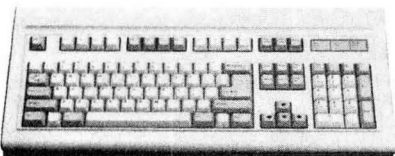

- ### TACTILE FEEDBACK MAXI-SWITCH
- MAX-5339 ENHANCED STYLE (SHOWN) **\$84.95**
MAX-5060 84 KEY LAYOUT **\$64.95**
- ### BTC ENHANCED STYLE LAYOUT
- AUTOSENSE FOR XT OR AT COMPATIBLES
 - LED INDICATORS
 - AUTO REPEAT FEATURE
 - SEPARATE CURSOR PAD
- BTC-5339 **\$79.95**
- ### BTC 84 KEY LAYOUT
- SOFTWARE AUTOSENSE FOR XT OR AT COMPATIBLES
 - LED INDICATORS
 - AUTO REPEAT
- BTC-5060 **\$59.95**
- ### BTC AUDIBLE "CLICK" KEYBOARD
- ENHANCED STYLE, 101 KEY KEYBOARD
 - LED INDICATORS
 - AUTO REPEAT
- K103-A **\$84.95**

1.44 MB 3 1/2" DRIVE

\$99.95

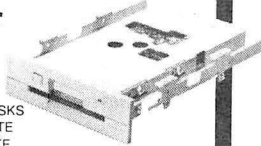

- ULTRA HIGH DENSITY
- ALSO WORKS WITH 720K DISKS
- FDD-1.44X BLACK FACEPLATE
- FDD-1.44A BEIGE FACEPLATE
- FDD-SOFT SOFTWARE DRIVER \$19.95

1/2 HEIGHT FLOPPY DISK DRIVES

FD-55B	5-1/4" TEAC DS/DD 360K	\$99.95
FD-55G	5-1/4" TEAC DS/HD 1.2M	\$129.95
M2551A	5-1/4" FUJITSU DS/HD 360K	\$89.95
M2553K	5-1/4" FUJITSU DS/HD 1.2M	\$119.95
FDD-360	5-1/4" DS/DD 360K	\$69.95
FDD-1.2	5-1/4" DS/HD 1.2M	\$109.95
MF355X	3-1/2" MITSUBISHI 1.44MB (BLACK)	\$129.95
MF355A	3-1/2" MITSUBISHI 1.44MB (BEIGE)	\$129.95
FDD-3.5X	3-1/2" DS/DD 720K (BLACK)	\$97.95
FDD-3.5A	3-1/2" DS/DD 720K (BEIGE)	\$97.95

TAPE BACK-UP DRIVES

AR5240X	ARCHIVE TAPE DRIVE -XT'S & AT'S	\$369.95
AR5540A	FASTER TAPE DRIVE -AT'S ONLY	\$369.95
AR340	40 MB TAPE CARTRIDGES	\$24.95

DISKETTES

N-MD2D	BOX OF 10 5-1/4" 360K DS/DD	\$6.95
N-MD2H	BOX OF 10 5-1/4" 1.2 MB DS/HD	\$13.95
N-3.5DS	BOX OF 10 3-1/2" 720K DS/DD	\$16.95
N-3.5HD	BOX OF 10 3-1/2" 1.44 MB DS/HD	\$49.95
N-MD2D BULK	360K DS/DD (MIN. 50 DISKS)	EA. 49c

DRIVE ACCESSORIES

FD-ARAIL	MTG. RAILS FOR AT COMPATIBLE	\$2.95
FD-55MHW	HALF-HEIGHT MOUNTING HARDWARE	\$2.95
FD-5Y	Y-POWER ADAPTOR FOR DRIVES	\$2.95
FD55P	BEIGE FACEPLATE FOR TEAC DRIVES	\$2.95

Seagate

Kits include a Seagate hard disk drive, drive controller, cables and instructions.
 HDKIT20 20 MB System Kit
 HDKIT30 30 MB System Kit

20 Mb kit \$269

30 Mb kit \$299



SIZE	MODEL	AVG. SPEED	HT.	DRIVE ALONE	With MCT Controller			
					HDC	RLL	AFH	AFH-RLL
20MB	ST-225	65 ms	Half	\$225	\$269	-	\$339	-
30MB RLL	ST-238	65 ms	Half	\$249	-	\$299	-	\$389
40MB	ST-251	40 ms	Half	\$379	\$419	-	\$489	-
40MB	ST-251-1	28 ms	Half	\$469	\$509	-	\$579	-
60MB RLL	ST-277	40 ms	Half	\$449	-	\$499	-	\$589
30MB	ST-4038	40 ms	Full	\$559	\$603	-	\$659	-
80MB	ST-4096	28 ms	Full	\$629	-	-	\$729	-

INBOARD 386/PC

\$895⁰⁰



- UPGRADE YOUR XT TO A 386 FOR LESS THAN \$900
- 16 MHZ PROCESSOR REPLACES 8088
 - 1 MB MEMORY INSTALLED
 - EXPAND TO 3 MB WITH PIGGYBACK CARD
 - 5 YEAR WARRANTY
- PCIB 1200**
PIGGYBACK MEMORY BOARDS
- | | | |
|----------|----------------|-----------|
| PCIB1210 | 1 MB INSTALLED | \$649.00 |
| PCIB1220 | 2 MB INSTALLED | \$1195.00 |

"JDR MICRODEVICES IS FIRST CLASS TO DEAL WITH, VERY PROFESSIONAL AND FRIENDLY."
 --J.A. COFFIN, ISLESBORO, ME

"YOUR AVAILABILITY AND WILLINGNESS TO ATTEND TO OUR NEEDS WITH PROMPT, COURTEOUS PERSONNEL IS GREATLY APPRECIATED."
 --DIANE M. DUBOIS, SAN JOSE, CA

"SHOP-BY-PHONE COMPUTER MAIL ORDER HAS NEVER BEEN MORE ENJOYABLE NOW THAT I HAD THE GOOD SENSE TO CALL JDR --I'M SORRY NOW THAT I WAITED SO LONG."
 --K. BOGGS, PARADISE, CA

INTERFACE CARDS

BY MODULAR CIRCUIT TECHNOLOGY

DRIVE CONTROLLERS

FLOPPY DISK CONTROLLER \$29.95
 SINGLE SLOT CONTROL OF 4 FLOPPIES
 ■ INTERFACES UP TO 4 FDD'S TO AN IBM PC OR COMPATIBLE ■ SUPPORTS DS/DD AND DS/QD W/ DOS 3.2
MCT-FDC

1.2 MB FLOPPY CONTROLLER \$69.95
 ADD VERSATILITY AND CAPACITY TO YOUR XT
 ■ SUPPORTS 2 DRIVES, CAN MIX 360K AND 1.2 MB
 ■ ALLOWS DATA TO FLOW FREELY FROM XT'S TO AT'S
MCT-FDC-1.2

FLOPPY/HARD CONTROLLER \$139.95
 XT SYSTEM SHORT OF SLOTS? THIS CARD FREES ONE UP!
 ■ INTERFACES UP TO 2 FDD'S & 2 HDD'S, CABLING FOR 2 FDD/1HDD ■ SUPPORTS BOTH DS/DD & DS/QD W/DOS 3.2
MCT-FH

286/386 FLOPPY/HARD \$149.95
 FLOPPY/HARD DISK CONTROL IN A TRUE AT DESIGN
 ■ SUPPORTS UP TO 2 360K/720K/1.2 MB FDD'S
 ■ SUPPORTS 2 HDD'S USING STANDARD TABLES
MCT-AFH

HARD DISK CONTROLLER \$79.95
 HARD DISK CONTROL AT AN ECONOMICAL PRICE
 ■ SUPPORTS 16 DRIVE SIZES INCLUDING 10,20,30 & 40 MB
 ■ DIVIDE 1 LARGE DRIVE INTO 2 LOGICAL DRIVES
MCT-HDC

RLL CONTROLLER \$119.95
 TRANSFER DATA 50% FASTER
 ■ SUPPORTS UP TO 2 RLL HARD DRIVES
 ■ DESIGNED FOR XT COMPATIBLES
MCT-RLL

286/386 FLOPPY/HARD RLL \$199.95
 IMPROVE SPEED AND STORAGE OF YOUR AT COMPATIBLE
 ■ SUPPORTS UP TO 2 RLL HARD DISCS AND 2 FLOPPIES
 ■ SUPPORTS 360/720/1.2 MB FLOPPIES IN 5.25" & 3.5"
MCT-AFH-RLL

MULTIFUNCTION CARDS

MULTI I/O FLOPPY CONTROLLER \$79.95
 A PERFECT COMPANION FOR OUR MOTHERBOARDS
 ■ SUPPORTS UP TO TWO 360K FLOPPIES, 720K W/ DOS 3.2
 ■ SERIAL, PARALLEL, GAME PORT, CLOCK/CALENDAR
MCT-MIO
 MIO-SERIAL—2ND SERIAL PORT \$15.95

MULTI I/O CARD \$59.95
 USE WITH MCT-FH FOR MINIMUM OF SLOTS USED
 ■ SERIAL PORT, CLOCK/CALENDAR WITH BATTERY
 ■ PARALLEL PORT ADDRESSABLE AS LPT1 OR LPT2
MCT-IO

286/386 MULTIFUNCTION \$139.95
 ADDS UP TO 3 MB OF RAM TO YOUR AT
 ■ USER EXPANDABLE TO 1.5 MB OR 3 MB WITH OPTIONAL PIGGYBACK BOARD (OK INSTALLED) ■ INCLUDES SERIAL AND PARALLEL PORT
MCT-AMF
MCT-AMF-MC PIGGYBACK BOARD \$29.95
AIO -SERIAL 2ND SERIAL PORT \$24.95

286/386 MULTI I/O CARD \$59.95
 USE WITH MCT-AFH MINIMUM OF SLOTS USED
 ■ SERIAL, PARALLEL AND GAME PORTS ■ USES 16450 SERIAL SUPPORT CHIPS FOR HIGH SPEED OPS
MCT-AIO
AIO-SERIAL 2ND SERIAL PORT \$24.95

MEMORY CARDS

576K RAM CARD \$59.95
 A CONTIGUOUS MEMORY SOLUTION IN A SHORT SLOT
 ■ USER SELECTABLE CONFIGURATION UP TO 576K
 ■ USES 64K & 256K RAM CHIPS (OK INSTALLED)
MCT-RAM

EXPANDED MEMORY CARD \$129.95
 2MB OF LOTUS INTEL MICROSOFT MEMORY FOR AN XT
 ■ CONFORMS TO LOTUS INTEL EMS ■ USER EXPANDABLE TO 2 MB ■ CAN BE USED AS EXPANDED OR CONVENTIONAL MEMORY, RAMDISK AND SPOOLER
MCT-EMS
MCT-AEMS 286/386 VERSION \$139.95

DISPLAY ADAPTORS

MONOCHROME GRAPHICS \$59.95

TRUE HERCULES COMPATIBILITY SUPPORTS LOTUS 1-2-3
 ■ PARALLEL PRINTER PORT CONFIGURES AS LPT1 OR LPT2 ■ USES VLSI CHIPS TO ENSURE RELIABILITY
MCT-MGP

EGA ADAPTOR \$149.95

100% IBM COMPATIBLE PASSES IBM EGA DIAGNOSTICS
 ■ 256K OF VIDEO RAM ALLOWS 640 X 350 IN 16 OF 64 COLORS ■ COMPATIBLE WITH COLOR AND MONOCHROME ADAPTORS ■ HERCULES COMPATIBLE
MCT-EGA

COLOR GRAPHICS ADAPTOR \$49.95

COMPATIBLE WITH IBM GRAPHICS STANDARDS
 ■ SUPPORTS RGB, COLOR, & COMPOSITE MONOCHROME
 ■ 640/320 X 200 RESOLUTION, LIGHT PEN INTERFACE
MCT-CG

MONOGRAPHICS MULTI I/O \$119.75

TOTAL SYSTEM CONTROL FROM A SINGLE SLOT!
 ■ CTRL 2 FLOPPIES, SERIAL, PARALLEL, GAME PORT, CLOCK CAL ■ RUN COLOR GRAPHICS SOFTWARE ON A MONOCHROME MONITOR
MCT-MGMIO

286/386 MONOGRAPHICS I/O \$99.95

USE THIS "DO EVERYTHING" CARD TO HOOK UP YOUR MONOCHROME MONITOR, PARALLEL PRINTER, MODEM AND JOYSTICK AT THE SAME TIME. THE ONLY OTHER CARD YOUR SYSTEM NEEDS IS A FLOPPY/HARD CONTROLLER.
 ■ AT COMPATIBLE
 ■ 720 X 348 RESOLUTION, 80 & 132 COLUMN TEXT
 ■ PARALLEL, SERIAL & GAME PORTS
 ■ HERCULES COMPATIBLE MONOGRAPHICS
 ■ INCLUDES SOFTWARE FOR RUNNING COLOR GRAPHICS PROGRAMS ON A MONOCHROME MONITOR.
MCT-MGAIO

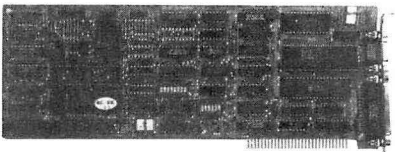

JDR MICRODEVICES, 110 KNOWLES DRIVE, LOS GATOS, CA 95030
 LOCAL (408) 866-6200 FAX (408) 378-8927 TELEX 171-110

RETAIL STORE: 1256 SOUTH BASCOM AVE., SAN JOSE, CA (408) 947-8881
 HOURS: M-F 9-7 SAT. 9-5 SUN. 12-4

Terms: Minimum order \$10. For shipping and handling include \$3.50 for ground and \$4.50 air. Orders over 1 lb and foreign orders may require additional shipping charges—please contact the sales department for the amount. CA residents must include applicable sales tax. Prices subject to change without notice. We are not responsible for typographical errors. We reserve the right to limit quantities and to substitute manufacturer. All merchandise subject to prior sales. A full copy of our terms is available upon request. Items pictured may only be representative.

ORDER TOLL FREE 800-538-5000

COPYRIGHT 1989 JDR MICRODEVICES

BUILD YOUR OWN SYSTEM

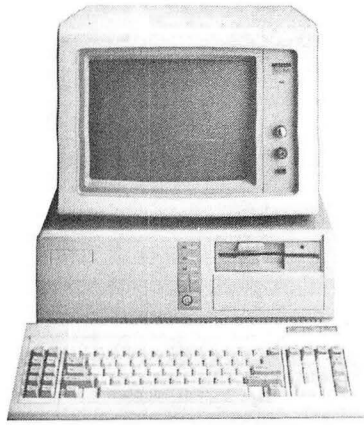

OVER 20,000 JDR SYSTEMS HAVE ALREADY BEEN BUILT. EASY TO ASSEMBLE IN JUST 2 HOURS WITH A SCREWDRIVER.

12 MHz MINI-286 \$1232.75

- 12 MHz MINI-286 MOTHERBOARD ■ 512K RAM MEMORY
- MINI-AT CASE WITH POWER SUPPLY
- 84 KEY KEYBOARD ■ MONOCHROME MONITOR
- 1.2 MB FLOPPY DRIVE ■ FLOPPY / HARD CONTROL
- GRAPHICS ADAPTOR

10 MHz TURBO 8088 \$661.00

- INCLUDES SERIAL PORT, 2 PARALLEL PORTS, CLOCK/CALENDAR AND GAME ADAPTOR ■ RUNS COLOR GRAPHICS ON A MONOCHROME MONITOR
- MOTHERBOARD ■ 256K RAM MEMORY ■ 135 WATT POWER SUPPLY ■ FLIP-TOP CASE ■ 84 KEY KEYBOARD
- 360K FLOPPY DRIVE ■ MONOGRAPHICS I/O CARD
- MONOCHROME MONITOR

MOTHERBOARDS

TURBO 4.77/8 MHz \$99.95

- XT COMPATIBLE ■ NORTON SI 1.7 ■ 4.77 OR 8 MHz OPERATION WITH 8088-2 AND OPTIONAL 8087-2 CO-PROCESSOR ■ FRONT PANEL LED SPEED INDICATOR AND RESET SWITCH SET SUPPORTED ■ CHOOSE NORMAL/TURBO MODE OR SOFTWARE SELECT PROCESSOR SPEED

MCT-TURBO

MCT-XMB STANDARD MOTHERBOARD \$87.95

10 MHz SINGLE CHIP \$129.95

- XT COMPATIBLE ■ NORTON SI 2.1 ■ USES LESS POWER, IMPROVES RELIABILITY ■ KEY SELECTABLE SPEED, 4.77 MHz OR 10 MHz ■ 2.3 TIMES FASTER THAN A STANDARD ■ RESET SWITCH, KEYLOCK, & SPEED / POWER INDICATORS SUPPORTED

MCT-TURBO-10

80286 6/10 MHz \$379.95

- AT COMPATIBLE ■ LANDMARK AT SPEED 10 MHz
- NORTON SI 10.3 ■ 8 SLOTS (TWO 8-BIT, SIX 16-BIT) ■ HARDWARE SELECTION OF 6 OR 10 MHz
- FRONT PANEL LED INDICATOR ■ SOCKETS FOR 1MB OF RAM AND 80287 ■ ONE WAIT STATE
- BATTERY BACKED CLOCK ■ KEYLOCK SUPPORTED ■ RESET SWITCH

MCT-286

12 MHz MINI-286 \$399.95

- AT COMPATIBLE ■ LANDMARK AT SPEED 13.2 MHz
- NORTON SI 11.6 ■ 6 MHz, 10 MHz (0/1 WAIT STATE), 12 MHz (1 WAIT STATE) ■ ZYMOUS ASICS FOR FEWER CHIPS, GREATER RELIABILITY ■ SUPPORTS 512K-1024K MEMORY ■ RECHARGEABLE HIGH CAPACITY NI-CAD BATTERY ■ SIX 16-BIT SLOTS, TWO 8-BIT SLOTS
- MOUNTS IN STANDARD XT CASE

MCT-M286-12

MCT-M286 6/10 MHz MINI 80286 BOARD \$389.95

NEW! MODULAR PROGRAMMING SYSTEM

MODULAR CIRCUIT TECHNOLOGY

THE IDEAL SYSTEM FOR DEVELOPERS; AN INTEGRATED MODULAR SYSTEM THAT EXPANDS AS YOUR NEEDS GROW. ALL THE MODULES USE A COMMON HOST ADAPTOR CARD SO YOU NEED JUST ONE SLOT TO PROGRAM EPROMS, PROMS, PALS AND MORE.

HOST ADAPTOR CARD \$29.95

- A UNIVERSAL INTERFACE FOR ALL THE PROGRAMMING MODULES
- USER SELECTABLE PROGRAMMABLE ADDRESSES PREVENT ADDRESSING CONFLICTS
- INCLUDES MENU-DRIVEN SOFTWARE PACKAGE
- INCLUDES MOLDED CABLE

MCT-MAC

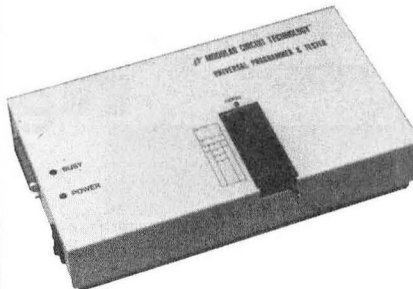
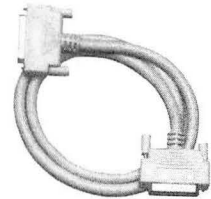
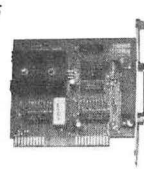

UNIVERSAL MODULE \$499.99

- PROGRAMS EPROMS, EEPROMS, PALS, BI-POLAR PROMS, 8748 & 8751 SERIES DEVICES
- PROGRAMS 16V8 & 20V8 GALs (GALLIUM ARSENIDE) FROM LATTICE, NS, SGS
- TESTS TTL, CMOS, DYNAMIC & STATIC RAMS
- LOAD DISK, SAVE DISK, EDIT, BLANK CHECK, PROGRAM, AUTO, READ MASTER, VERIFY & COMPARE
- TEXT TOOL, SOCKET ACCEPTS .3 TO .6" WIDE IC'S FROM 8-40 PINS

MCT-MUP

EPROM MODULE \$119.95

- PROGRAMS 24-32 PIN EPROMS, CMOS EPROMS AND EEPROMS FROM 16K TO 1024K
- HEX TO OBJ CONVERTER
- AUTO, BLANK CHECK/PROGRAM/VERIFY
- VPP 5, 12.5, 12.75, 13, 21 & 25 VOLTS
- NORMAL, INTELLIGENT, INTERACTIVE, & QUICK PULSE PROGRAMMING ALGORITHMS

MCT-MEP

MCT-MEP-4 FOUR-EPROM PROGRAMMER \$169.95

MCT-MEP-8 EIGHT-EPROM PROGRAMMER \$259.95

MCT-MEP-16 SIXTEEN-EPROM PROGRAMMER \$499.95

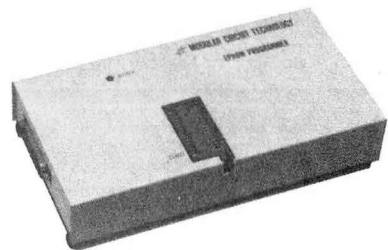

DIGITAL IC MODULE \$129.95

- TESTS TTL, CMOS, DYNAMIC & STATIC RAM
- AUTO SEARCH FOR UNKNOWN PART NUMBERS
- USER-PROGRAMMABLE TEST PROCEDURES

MCT-MIC

PAL MODULE \$249.95

- PROGRAMS MMI, NS, TI 20 & TI 24 PIN DEVICES
- BLANK CHECK, PROGRAM, AUTO, READ MASTER, VERIFY & SECURITY FUSE BLOW

MCT-MPL

PAL PROGRAMMING DEVELOPMENT SOFTWARE \$99.95

MCT-MPL-SOFT

8748 MODULE \$179.95

- PROG. 8741, 8742, 8748, 8749 & 8750 EPROMS & PROMS
- LOAD DISK, SAVE DISK, EDIT, BLANK CHECK, PROGRAM, AUTO, READ MASTER, VERIFY & COMPARE
- NORMAL & INTELLIGENT PROGRAMMING ALGORITHMS

MCT-MMP

BI-POLAR MODULE \$259.95

- PROG. AMD, MMI, NS, TI & SIGNETICS BI-POLAR PROMS
- LOAD DISK, SAVE DISK, EDIT, BLANK CHECK, PROGRAM, AUTO, READ MASTER, VERIFY

MCT-MBP

EPROM PROGRAMMER \$129.95

- PROGRAMS 27XX AND 27XXX EPROMS UP TO 27512
- SUPPORTS VARIOUS PROGRAMMING FORMATS & VOLTAGES
- SPLIT OR COMBINE CONTENTS OF SEVERAL EPROMS OF DIFFERENT SIZES
- READ, WRITE, COPY, ERASE CHECK & VERIFY
- SOFTWARE FOR HEX AND INTEL HEX FORMATS

MCT-EPROM

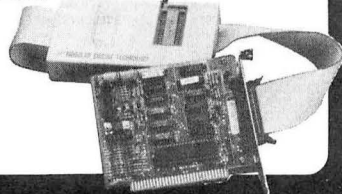

BARGAIN HUNTER'S CORNER CITIZEN PRINTER \$169.95

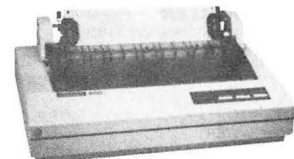

- 9 PIN DOT MATRIX PRINT HEAD
- 180 CPS DRAFT MODE, 29 CPS NLQ MODE
- CENTRONICS PARALLEL INTERFACE, SERIAL OPTIONAL
- DUAL PITCH, DOUBLESTRIKE, ITALICS & SUPERSCRIP
- DOT ADDRESSABLE GRAPHICS IN SIX DENSITIES
- COMPRESSED, EXPANDED AND EMPHASIZES PRINT

RC-180D
SPECIAL ENDS 3/31/89

Terms: Minimum order \$10. For shipping and handling include \$3.50 for ground and \$4.50 for air. Orders over 1 lb and foreign orders may require additional shipping charges—please contact the sales department for the amount. CA residents must include applicable sales tax. Prices subject to change without notice. We are not responsible for typographical errors. We reserve the right to limit quantities and to substitute manufacturer. All merchandise subject to prior sales. A full copy of our terms is available upon request. Items pictured may only be representative.



JDR MICRODEVICES, 110 KNOWLES DRIVE, LOS GATOS, CA 95030
LOCAL (408) 866-6200 FAX (408) 378-8927 TELEX 171-110

RETAIL STORE: 1256 SOUTH BASCOM AVE., SAN JOSE, CA (408) 947-8881
HOURS: M-F 9-7 SAT. 9-5 SUN. 12-4

ORDER TOLL FREE 800-538-5000

COPYRIGHT 1989 JDR MICRODEVICES

CONTINENTAL U.S.

Microcomputer News On-line

In this fast paced industry, can you afford to wait a week or a month for information that may affect you today?

MicroBYTES Daily is an electronic news service covering the latest developments in the microcomputer industry. If it concerns MSDOS machines, Macintosh, Unix workstations, peripherals, networks or software, you will find it in MicroBYTES.

Fast and Easy

Read the items as they break or use the powerful search command to quickly locate your information. Best of all you can download the text and print it or use it in your favorite word processor.

Whether you are a developer, marketer, or researcher, you need reliable information and you can count on MicroBYTES. Backed by the combined resources of BYTE Magazine, BYTEweek, and BIX, MicroBYTES gives you access to our world-wide network of reporters and the integrity and experience of our editorial staff.

In your position as a leader in new technology, you cannot afford to be just one of the crowd. Get ahead with MicroBYTES.

See our ad on pages 298, 299 of this issue.

Call now and subscribe today.

The logo for BIX, consisting of the letters 'BIX' in a bold, sans-serif font. The 'B' and 'I' are connected, and the 'X' is slightly larger and more prominent.

One Phoenix Mill Lane, Peterborough, NH 03458
1-800-227-2983 ♦ In NH (603) 924-7681

EDITORIAL INDEX BY COMPANY

Index of companies covered in articles, columns, or news stories in this issue
Each reference is to the first page of the article or section in which the company name appears

INQUIRY #	COMPANY	PAGE	INQUIRY #	COMPANY	PAGE	INQUIRY #	COMPANY	PAGE
A			CREO PRODUCTS 274			M		
1109	ABAIRE INFORMATION SERVICES	65	1059	CYPRESS SEMICONDUCTOR	245		MANUFACTURING AND CONSULTING SERVICES	255
1115	ACCEL TECHNOLOGIES	65	D			1041	MANX SOFTWARE SYSTEMS	170
1037	ADDISON-WESLEY PUBLISHING	51, 97		DIGITAL EQUIPMENT	229, 255	1024	MAXIMUM STORAGE	121
1141	ADVANCED LOGIC RESEARCH	65		DIGITAL RESEARCH	11		MAXTOR	11, 293
1058	ADVANCED MICRO DEVICES	11, 245		DORSET HOUSE PUBLISHING	51	1042	MEDIAGENIC	11
	AMERICAN ELECTRONICS ASSOCIATION	11		DTK	157	1110	METAWARE	170
	AMERICAN MEGATRENDS	11	1106	DYNAMIC COMPUTER PRODUCTS	151		MICRO DATA BASE SYSTEMS	65
	AMI	157	E			1035	MICRO SOLUTIONS	97
983	APOLLO COMPUTER	229, 235, 255		ELECTRONIC ARTS	11	1043	MICROSOFT	11, 65, 170, 205, 229
1102	APPLE COMPUTER	11, 113, 1103	1117	ENGINEERING SOFTWARE	65	1055		
1105		151, 229, 293		EPYX	11	1108		
1151	ARISTOTLE INDUSTRIES	65	F			1104	MICROSOFT PRESS	151
1022	ASHTON-TATE	139, 211, 217	1136	FIFTH GENERATION SYSTEMS	65	1023	MINDSCAPE	139
1065			1113	FORESIGHT RESOURCES	65	1064	MIPS COMPUTER SYSTEMS	245
1066				FORMALSOFT	11		MIT	11
1032	ASIACOM	121	G			860	MITSUBISHI ELECTRONICS AMERICA	11, 189
	AT&T	267		GADGETS BY SMALL	11	1036	MORTICE KERN SYSTEMS	97
	ATHENA SYSTEMS	11	1150	GCC TECHNOLOGIES	65	1062	MOTOROLA	11, 245, 251
1129	AUTOMATED DESIGN	65	1122	GENESIS DATA SYSTEMS	65	N		
	AWARD	157	1025	GTA	121		NATIONAL ENGINEERS WEEK	11
B			H			1154	NATIONAL INSTRUMENTS	65
	BANYAN SYSTEMS	229	1163	HAYES MICROCOMPUTER PRODUCTS	65	984	NEXT	235, 293
	BECHTEL	255		HEWLETT-PACKARD	11, 229		NMB TECHNOLOGIES	11
	BERNOULLI OPTICAL SYSTEMS	274		HITACHI	11	981	NOVELL	145, 229
1131	BIT SOFTWARE	65	1134	HOGWARE	65	O		
1040	BORLAND INTERNATIONAL		1148	HYBRID FAX	65		OLYMPUS OPTICAL	11
1056		11, 109, 170, 205, 283	I				OPTOTECH	11
1067			1165	IBM	65, 157, 229, 293	1153	OPUS SYSTEMS	65
C				ICI IMAGEDATA	274	P		
1034	CAMBRIDGE NORTH AMERICA	121	1033	INTEL	11, 121, 245, 251	1028	PAUL MACE SOFTWARE	121
1021	CANON U.S.A.	139	1060			1029	PETER NORTON COMPUTING	121
	CARVER MEAD AND ASSOCIATES	11		INTELLIGENT LIGHT	255		PHOENIX	157
1144	CLUB AMERICAN TECHNOLOGIES	65	1061	INTERGRAPH INTERNATIONAL FOUNDATION FOR THE SURVIVAL AND DEVELOPMENT OF HUMANITY	11	1152	PLUS DEVELOPMENT	65
1101	COLBY COMPUTERS	151					PRENTICE-HALL	51
	COMPAQ COMPUTER	157	L				PRIME COMPUTER	229
1143	COMTEQ COMPUTER	65	1162	LANEX	65	Q		
1132	CONNECT COMPUTER	65	1039	LANGUAGE SYSTEMS	97	1026	QUARTERDECK OFFICE SYSTEMS	121
1147	CONSOLIDATED COMPUTER SYSTEMS	65	1164	LANTANA TECHNOLOGY	65	1126	QUOTRON SYSTEMS	65
	CONTROL DATA	293	R			1038	RAINBOW TECHNOLOGIES	97
1031	COPIA INTERNATIONAL	121					RASTER TECHNOLOGIES	255

INQUIRY #	COMPANY	PAGE
S		
	SANTA CRUZ OPERATION ...	229
	SCIENTIFIC MICRO SYSTEMS	11
	SEAGATE TECHNOLOGY.....	157
		293
985	SILICON GRAPHICS.229, 235, 255	
1137	SITBACK TECHNOLOGIES	65
1057	SLR SYSTEMS	205
	SOFTWARE PUBLISHERS	
	ASSOCIATION	11
	SOFTWARE SECURITY	
	SPECIAL INTEREST	
	GROUP	11
1146	SONY MICROSYSTEMS	65
	SPECTRUM HOLOBYTE	11
1114	SPSS	65
1030	STERLING CASTLE	
1107	SOFTWARE	65, 121
986	SUN MICROSYSTEMS	11, 229
1063		235, 245, 255, 267, 293
	SYBEX.....	51
	SYNAPTICS	11
1138	SYNTHETIC INTELLIGENCE ..	65
T		
858	TANDY	197
	TEKTRONIX	255
1121	TELECOM LIBRARY	65
982	3COM	145, 229
1145	TOSHIBA AMERICA	11, 65
1149		
1130	TRITON TECHNOLOGIES	65
1027	TSR HUTCHINSON.....	121
U		
	UNISYS.....	293
	UNIVERSITY OF MICHIGAN..	11
1157	US VIDEO.....	65
V		
1050	V COMMUNICATIONS	97
1128	VANO ASSOCIATES	65
1142	VIDEO GRAPHIC SYSTEMS ...	65
W		
	W. H. FREEMAN	51
	W. W. NORTON	51
1044	WATCOM.....	170
	WAVEFRONT.....	255
	WESTCON	11
	WESTERN DIGITAL.....	11
Z		
859	ZENITH DATA SYSTEMS	189
1045	ZORTECH.....	170

COMING UP IN BYTE

PRODUCTS IN PERSPECTIVE:

Leading off the March issue will be Microbytes, What's New, and Short Takes. Among the products scheduled for a look are an updated word processor, a new debugger, a novel LAN, and a graphics package for the Macintosh.

We're planning a **First Impression** on several 80386SX machines, with benchmarking and testing by the staff of the BYTE Lab.

March's **Product Focus** will concentrate on the increasingly popular category of large-screen monitors. Testing and analysis will again be done by the BYTE Lab, and the article will include 12 units.

System reviews for March cover two new portables from Compaq and Olivar and the new Wells American Micro Channel AT.

In **hardware reviews**, we've focused our attention on a new group of floppy disk drive controllers for the IBM PC. A second hardware review considers new high-capacity hard disk drives for the Macintosh.

Software reviews will consider several new text editors, a new multitasking operating system, and an applications development library for both the PC and the Macintosh. An **application review** will cover a new database management package, Superbase.

IN DEPTH:

Object-oriented programming languages and operating systems will be the topic. We'll begin with a piece by David Thomas on object-oriented design and programming; cover object-oriented user interfaces with Charles Hughes, J. Michael Moshell, and Mahesh Dodani

(with a text box by Bruce Blumberg on the NeXT object-oriented environment); and wrap up with Peter Wegner on object-oriented languages.

FEATURES:

Brett Glass goes **Under the Hood** of **high-performance memory systems**, Rick Grehan presents part 3 in his series on **trees 'n keys**, Dick Pountain describes the programming language **Occam II**, Fetchi Chen gives us

an inside look at the **design of PC-DOS 4.0**, Jim Kerr discusses **Unix filenames for MS-DOS**, and Frank Hayes **compares the 80286 with the 80386** and both of those with the **80386SX**.

READER SERVICE

To get further information on the products advertised in BYTE, fill out the reader service card by circling the numbers on the card that correspond to the inquiry number listed with the advertiser. This index is provided as an additional service by the publisher, who assumes no liability for errors or omissions.

* Correspond directly with company.

Index to Advertisers by Product Category

Inquiry No.	Page No.	Inquiry No.	Page No.	Inquiry No.	Page No.	Inquiry No.	Page No.
HARDWARE							
268	ADD INS	128	LINK COMPUTER GRAPHICS 334	164	NANAO 144	426	MICROPHAR IS-16
12	ALPHA PRODUCTS 332,333	271	INSTRUMENTATION	165	NANAO 144	184	PROTECH MARKETING 214
23	ATI TECHNOLOGIES 93	83	ELEXOR 338	276	NETWORK HARDWARE	195	RAINBOW TECH 179
29	B & C MICROSYSTEMS 327	119	J.B. COMPU-TRONIX 336	33	BAY TECHNICAL ASSOC. 43	196	RAINBOW TECH 179
30	B & C MICROSYSTEMS 327	272	KEYBOARDS/MICE	41	BUFFALO PRODUCTS 35	197	RAINBOW TECH 338
403	BLUE CHIP TECHNOLOGY IS-26	113	ITAC SYSTEMS, INC. 130	51	CARRIER CURRENT TECH 96	238	VAULT 210
49	CAPITAL EQUIPMENT 128	133	LOGITECH 22,23	52	CARRIER CURRENT TECH 96	282	SYSTEMS
50	CAPITAL EQUIPMENT 129	134	LOGITECH 22,23	408	CUBIX IS-27	401	ACME TECHNOLOGY IS-28
259	CLEARPOINT 237	441	UNITECH IS-20	410	DATEX IS-21	* AMPRO 126	
66	CONTROL VISION 334	273	MASS STORAGE	490	NET LOGIC M/AT-3	* AST RESEARCH 193	
408	CUBIX IS-27	11	AK SYSTEMS 322	491	NET LOGIC M/AT-3	477	BELTRON COMPUTER SO-1
69	DATA TRANSLATION 31	31	BASF 141	179	PERSONAL SPACE COMM. 329	34	BEST COMPUTER 204
82	EDC GMBH 92	32	BASF 143	432	RINGDALE PERIPHERALS IS-45	35	BEST COMPUTER 204
96	GENOA 75	36	BIOLOGICAL ENGINEERING 30	200	ROSE ELECTRONICS 162	498	COM-TEK DATA MW-3
417	INTERQUADRAM IS-7	428	NIPPON COLUMBIA IS-33	248	WIESEMANN & THEIS 140	499	COM-TEK DATA MW-3
418	INTERQUADRAM IS-9	172	OVERLAND DATA 329	277	POWER SUPPLIES	508	COM-TEK DATA NE-11
419	INTERQUADRAM IS-11	190	QUALSTAR 338	479	DRS POWER SO-5	509	COM-TEK DATA NE-11
111	IO TECH 111	* MISCELLANEOUS		480	DRS POWER SO-5	71	DATAWORLD 196
112	IO TECH 338	33	BAY TECHNICAL ASSOC. 43	85	EMERSON COMPUTER POWER 16	72	DATAWORLD 196
425	MICROMINT IS-18	41	BUFFALO PRODUCTS 35	86	EMERSON COMPUTER POWER 16	73	DELL COMPUTER CORP. CII,1
481	NEWER TECHNOLOGY SO-7	67	COVOX 336	175	PARA SYSTEMS 41	74	DELL COMPUTER CORP. 81
519	NEWER TECHNOLOGY NE-15	409	DATAMAN LTD IS-47	206	SCOPE ELECTRONICS 329	79	DTK 228
537	NEWER TECHNOLOGY PC-8	257	ENGINEERS COLLABORATIVE 336	278	PRINTERS/PLOTTERS	80	DTK 228
170	NOHAU CORP. 180	104	HARRIS/3M 288,289	33	BAY TECHNICAL ASSOC. 43	411	ELONEX IS-25
179	PERSONAL SPACE COMM. 329	* INTECTRA 325		41	BUFFALO PRODUCTS 35	412	E.E.P.D. GMBH IS-24
430	PHILIPS IS-4	108	INTEGRAND 40	137	MANNESMANN TALLY 155	88	FIVESTAR COMPUTERS 36,37
186	QUA TECH 330	421	KADOR IS-40	138	MANNESMANN TALLY 155	95	GATEWAY 2000 87
187	QUA TECH 330	129	LOGICAL DEVICES 329	254	ZERICON 201	513	HERTZ COMPUTER NE-5
188	QUA TECH 330	130	LOGICAL DEVICES 329	279	PRINTER RIBBONS	262	IEEE 234
189	QUA TECH 330	131	LOGICAL DEVICES 329	60	COMPUTER FRIENDS 44	515	LOGIX MICROCOMPUTER NE-8
198	REAL TIME DEVICES 327	132	LOGICAL DEVICES 329	280	SCANNERS/DIGITIZERS	516	LOGIX MICROCOMPUTER NE-8
210	SMIS 94	147	MEGATEL 104	69	DATA TRANSLATION 31	517	LOGIX MICROCOMPUTER NE-8
437	TECHPOWER CO. IS-38	251	XELTEK 330	89	FLAGSTAFF ENGINEERING 120	146	MEGASOFT 330
237	TRUEVISION 219	274	MODEMS/MULTIPLEXORS	90	FLAGSTAFF ENGINEERING 120	* NEC HOME ELECT. 272,273	
255	Z-WORLD 338	* CLEO SOFTWARE IS-19		91	FLAGSTAFF ENGINEERING 120	* NEC INFORMATION SYS. CIII	
269	DRIVES	57	COMPUCOM CORP. 54	92	FLAGSTAFF ENGINEERING 120	492	OWL COMPUTERS M/AT-1
* SEAGATE 39		169	NATURAL MICROSYSTEMS 262	105	HIGH RES TECHNOLOGIES 322	185	PROTEUS TECH. CORP. 27
226	SYSGEN, INC. 17	227	TELCOR 246	135	LOGITECH 70,71	193	RADIO SHACK CIV
231	TIGERTRONICS 60	228	TELEBIT 164,165	136	LOGITECH 70,71	194	RADIO SHACK 117
270	HARDWARE PROGRAMMERS	234	TOUCHBASE SYSTEMS INC. 18	236	TRUE DATA 46	199	RENEGADE TECHNOLOGY 8,9
29	B & C MICROSYSTEMS 327	275	MONITORS	281	SOFTWARE SECURITY	540	SF MICRO PC-15
30	B & C MICROSYSTEMS 327	155	MITSUBISHI MONITORS 124,125	404	BRISTOL SOFTWARE IS-41	541	TODAY COMPUTERS PC-1
40	BP MICROSYSTEMS 322	156	MITSUBISHI MONITORS 124,125	407	COMP. ELEKTRONIK INFOSYS IS-15	542	TODAY COMPUTERS PC-1
43	BYTEK 325					439	TOPLINK COMP. CO. LTD. IS-32
100	GTEK INC. 92					232	TOSHIBA COMPUTERS 106,107
123	KORE 336					233	TOSHIBA COMPUTERS 106,107

READER SERVICE

Advertising Supplement included with this issue:
Priority One Electronics (U.S. and Canada Subscribers)

* Correspond directly with company.

Inquiry No. Page No.
253 ZEOS INTERNATIONAL ... 168,169

SOFTWARE

283 IBM/MS-DOS APPLICATIONS
Business/Office

* APPLIED COMPUTING SERV. 209
16 ASHTON-TATE 101
17 ASHTON-TATE 101
18 ASHTON-TATE 103
19 ASHTON-TATE 103
20 ASHTON-TATE 105
21 ASHTON-TATE 105
533 BRADFORD BUS. SYSTEMS . PC-2
93 FOX SOFTWARE 25
94 FTG DATA SYSTEMS 334
413 GAMMA PRODUCTIONS IS-30
166 NANTUCKET 55
429 NOVELL DEVELOPMENT ... IS-31
* ORACLE 73
* RAIMA 185
433 SBT IS-2
225 SYMANTEC 45
240 VERSASOFT 90

284 IBM/MS-DOS APPLICATIONS
Scientific/Technical

405 CAMBRIDGE CONTROL LTD. IS-44
81 ECOSOFT 213
414 GOLDEN VERWER & PARTNERS . IS-42
101 HAMMERLY 61
416 INES IS-26
422 LOGIC PROGRAMMING ASSOC. . IS-28
139 MATHSOFT 67
167 NATIONAL INSTRUMENT 150
168 NATIONAL INSTRUMENT 150
176 PATTON & PATTON 122
218 SPECTRUM SOFTWARE 79
219 STATSOFT 123
221 STSC STATGRAPHICS 131
222 SUNFLEX SOFTWARE 215
223 SUNFLEX SOFTWARE 215

285 IBM/MS-DOS APPLICATIONS
Word Processing

443 WORDPERFECT CORP. IS-17

286 IBM/MS-DOS — CAD

14 AMERICAN SM. BUS. COMP. . 138
45 CADAM 95

Inquiry No. Page No.
46 CADAM 95
431 RHV IS-29
249 WINTEK CORP. 5
250 WINTEK CORP. 327

287 IBM/MS-DOS — LAN

490 NET LOGIC M/AT-3
491 NET LOGIC M/AT-3
208 SIMPLE NET SYSTEMS 167
209 SIMPLE NET SYSTEMS 167

288 IBM/MS-DOS — GRAPHICS

* DAYTRON ELECTRONICS 334
143 MEDIA CYBERNETICS 188
177 PAUL MACE SOFTWARE 32

289 IBM/MS-DOS — LANGUAGES

8 A + L MEIER VOGT 305
* BINARY TECH 322
38 BORLAND 69
39 BORLAND 69
84 ELLIS COMPUTING, INC. 134
101 HAMMERLY 61
118 JENSEN & PARTNERS, INT'L. . 133
126 LAHEY COMPUTER SYSTEMS 264
* MICROSOFT 13
* MICROSOFT 15
* MICROSOFT 118,119
159 MIX SOFTWARE 181
203 SANTA CRUZ OPERATION ... 85

290 IBM/MS-DOS — UTILITIES

9 A + L MEIER VOGT 307
15 ANNABOOKS 338
488 ARRAKIS CORPORATION . M/AT-2
489 ARRAKIS CORPORATION . M/AT-2
24 ATRON 64
* BINARY TECH 322
37 BLAISE 33
44 C SOURCE 187
* CALEND IS-49
47 CALIFORNIA SOFTWARE 322
48 CALIFORNIA SOFTWARE 322
406 COBALT BLUE IS-26
510 COPY TECHNOLOGIES NE-9
511 COPY TECHNOLOGIES NE-9
534 CORTEX COMPUTING PC-13
70 DATACODE, INC. 58
* DAYTRON ELECTRONICS 334
98 GOLDEN BOW 330
101 HAMMERLY 61
420 IXI LTD. IS-42
122 KNOWLEDGE GARDEN 223

Inquiry No. Page No.

140 MATRIX 127
160 MIX SOFTWARE 183
500 O.S. ASSOCIATES MW-2
501 O.S. ASSOCIATES MW-2
178 PAUL MACE SOFTWARE 147
256 PERISCOPE COMPANY 135
265 PETER NORTON 76,77
266 PETER NORTON 76,77
180 PHAR LAP SOFTWARE 26
192 QUARTERDECK 159
538 SAK TECHNOLOGY PC-9
204 SAX SOFTWARE 244
523 SOFTWARE BOTTLING CO. NE-13
263 SUPERSOFT 102
235 TRAVELING SOFTWARE 47
* VERMONT CREATIVE S/W 10
252 ZAMBINI BROTHERS S/W 186

291 IBM/MS-DOS COMMUNICATIONS

54 COEFFICIENT SYSTEMS 46
78 DIVERSIFIED COMPUTER 322
99 GRAFPOINT 336
121 KEA SYSTEMS 336
212 SOFTRONICS 327

292 OTHER — CROSS DEVELOPMENT

* SOFTWARE DEV. SYS. 99

293 MAIL ORDER/RETAIL

258 2001 SALES, INC. 152
531 3-F ASSOCIATES PC-3
476 4 GUYS COMPUTERS SO-2
532 4 GUYS COMPUTERS PC-4
26 ADVANCED COMP. PROD. ... 339
10 ADVANTAGE SOFTWARE 287
13 ALTEX ELECTRONICS 324
27 A.N. WHOLESALE & RETAIL . 322
28 B & B ELECTRONICS 325
* BUYERS MART 308-318
* CALIFORNIA DIGITAL 337
55 COMPACT DISK PRODUCTS ... 60
496 COMPARE COMPUTERS . MW-6,7
497 COMPARE COMPUTERS . MW-6,7
56 COMPUCLASSICS 250
58 COMPUSAVE 323
61 COMPUTER MAIL ORDER . 88,89
478 COMP. MASTERS OF AUG. ... SO-3
63 COMPUTER SURPLUS STORE 322
64 COMPUTERLANE UNLTD. ... 195
65 CONTECH COMPUTER CORP. 325
484 DALLAS SYSTEMS SO-6
76 DISKOCOTECH 338

Inquiry No. Page No.

77 DISKETTE CONNECTION ... 325
512 ELECTRIFIED DISCOUNTERSNE-3
87 EXECUTIVE PHOTO & SUPPLY 156
415 GREY MATTER IS-35
102 HARD DRIVES INT'L. 203
103 HARD DRIVES INT'L. 203
106 IC EXPRESS 325
107 INMAC 42
115 JADE COMPUTER 335
116 JAMECO 320-321
514 JASMINE COMPUTER SYST. NE-12
6 JDR MICRODEVICES 340-344
7 JDR MICRODEVICES 340-344
124 LA COMPUTER 326
125 LA COMPUTER 326
518 MANCHESTER EQUIP. CO. ... NE-1
423 MAYFAIR MICROS IS-37
142 MEAD COMPUTER 331
144 MEDIA CYBERNETICS 188
145 MEGASOFT 330
148 MERRITT COMPUTER PROD. . 104
149 MICHAEL HALVERSON & ASSOC. 336
424 MICRO TECHNOLOGY IS-39
150 MICROCOM SYSTEMS 24
* MICROCOMP. MKTG. COUNCIL 241
152 MICROPROCESSORS UNLTD. 329
153 MICROSTAR SOFTWARE 328
* MICROWAY 53
154 MICROWAY 153
536 MID-CITIES COMPUTERS ... PC-11
161 MONTGOMERY GRANT 216
162 MR. BOOKS, INC. 54
163 M.H.I. 319
173 PACIFIC COMPUTER 323
174 PACIFIC COMPUTER 323
520 PC LINK 7
482 PD SOFTWARE HOUSE SO-4
521 PD SOFTWARE HOUSE NE-10
181 PRINCETON DISKETTE 329
182 PROGRAMMER'S PARADISE 62,63
183 PROGRAMMER'S SHOP 134
201 SABINA 327
205 SCHWAB COMPUTER CTR. ... 327
539 SEVERE DISCOUNT COMP. PC-13
207 SHAMROCK 59
211 SN'W ELECTRONICS 182
* SOFTLINE CORPORATION ... IS-23
436 SOFTWARE APS IS-42
217 SOLUTION SYSTEMS 136
224 SURAH 327
260 S-100 194
261 S-100 194
229 TELEMART 52
230 TELEMART 52
483 UNDERWARE ELECTRONICS SO-8
493 UNDERWARE ELECTRONICS . M/AT-8
502 UNDERWARE ELECTRONICS MW-8

FREE INFORMATION

Want More Information About the Products and Advertisers Featured in this Issue?

1

Circle numbers on reply card which correspond to numbers assigned to items of interest to you.

2

Check all the appropriate answers to questions "A" through "C".

3

Print your name and address and mail.

Fill out this coupon carefully. PLEASE PRINT.

Name: _____

Title _____ Phone _____

Company _____

Address _____

City _____ State _____ Zip _____

A. What is your level of management responsibility?

- Senior-level Management
- Other Management
- Non-Management

B. What is your primary job function/principal area of responsibility? (Check one.)

- Administration
- Accounting/Finance
- MIS/DP/Information Center
- Product Design and Development
- Research and Development
- Manufacturing
- Sales/Marketing
- Purchasing
- Personnel
- Education/Training
- Other: _____

C. Please indicate your organization's primary business activity: (Check one.)

- Manufacturer (Hardware, Software)

- Computer Retail Stores
- Consultants
- Service Bureau/Planning
- Distributor/Wholesaler
- Systems House/Integrator/VAR
- Other: _____

Non-Computer-Related Businesses:

- Manufacturing
- Finance, Insurance, Real Estate
- Retail/Wholesale
- Education
- Government
- Military
- Professions (Law, Medicine, Engineering, Architecture)
- Consulting
- Other Business Services
- Transportation, Communications, Utilities
- Other: _____

1	2	3	4	5	6	7	8	9	10	11	12	13	14	15	16	17	18	19	20	21	22	23	24	25	26	27	28	29	30
31	32	33	34	35	36	37	38	39	40	41	42	43	44	45	46	47	48	49	50	51	52	53	54	55	56	57	58	59	60
61	62	63	64	65	66	67	68	69	70	71	72	73	74	75	76	77	78	79	80	81	82	83	84	85	86	87	88	89	90
91	92	93	94	95	96	97	98	99	100	101	102	103	104	105	106	107	108	109	110	111	112	113	114	115	116	117	118	119	120
121	122	123	124	125	126	127	128	129	130	131	132	133	134	135	136	137	138	139	140	141	142	143	144	145	146	147	148	149	150
151	152	153	154	155	156	157	158	159	160	161	162	163	164	165	166	167	168	169	170	171	172	173	174	175	176	177	178	179	180
181	182	183	184	185	186	187	188	189	190	191	192	193	194	195	196	197	198	199	200	201	202	203	204	205	206	207	208	209	210
211	212	213	214	215	216	217	218	219	220	221	222	223	224	225	226	227	228	229	230	231	232	233	234	235	236	237	238	239	240
241	242	243	244	245	246	247	248	249	250	251	252	253	254	255	256	257	258	259	260	261	262	263	264	265	266	267	268	269	270
271	272	273	274	275	276	277	278	279	280	281	282	283	284	285	286	287	288	289	290	291	292	293	294	295	296	297	298	299	300
301	302	303	304	305	306	307	308	309	310	311	312	313	314	315	316	317	318	319	320	321	322	323	324	325	326	327	328	329	330
331	332	333	334	335	336	337	338	339	340	341	342	343	344	345	346	347	348	349	350	351	352	353	354	355	356	357	358	359	360
361	362	363	364	365	366	367	368	369	370	371	372	373	374	375	376	377	378	379	380	381	382	383	384	385	386	387	388	389	390
391	392	393	394	395	396	397	398	399	400	401	402	403	404	405	406	407	408	409	410	411	412	413	414	415	416	417	418	419	420
421	422	423	424	425	426	427	428	429	430	431	432	433	434	435	436	437	438	439	440	441	442	443	444	445	446	447	448	449	450
451	452	453	454	455	456	457	458	459	460	461	462	463	464	465	466	467	468	469	470	471	472	473	474	475	476	477	478	479	480
481	482	483	484	485	486	487	488	489	490	491	492	493	494	495	496	497	498	499	500	501	502	503	504	505	506	507	508	509	510
511	512	513	514	515	516	517	518	519	520	521	522	523	524	525	526	527	528	529	530	531	532	533	534	535	536	537	538	539	540
541	542	543	544	545	546	547	548	549	550	551	552	553	554	555	556	557	558	559	560	561	562	563	564	565	566	567	568	569	570
571	572	573	574	575	576	577	578	579	580	581	582	583	584	585	586	587	588	589	590	591	592	593	594	595	596	597	598	599	600
601	602	603	604	605	606	607	608	609	610	611	612	613	614	615	616	617	618	619	620	621	622	623	624	625	626	627	628	629	630
631	632	633	634	635	636	637	638	639	640	641	642	643	644	645	646	647	648	649	650	651	652	653	654	655	656	657	658	659	660
661	662	663	664	665	666	667	668	669	670	671	672	673	674	675	676	677	678	679	680	681	682	683	684	685	686	687	688	689	690
691	692	693	694	695	696	697	698	699	700	701	702	703	704	705	706	707	708	709	710	711	712	713	714	715	716	717	718	719	720
721	722	723	724	725	726	727	728	729	730	731	732	733	734	735	736	737	738	739	740	741	742	743	744	745	746	747	748	749	750
751	752	753	754	755	756	757	758	759	760	761	762	763	764	765	766	767	768	769	770	771	772	773	774	775	776	777	778	779	780
781	782	783	784	785	786	787	788	789	790	791	792	793	794	795	796	797	798	799	800	801	802	803	804	805	806	807	808	809	810
811	812	813	814	815	816	817	818	819	820	821	822	823	824	825	826	827	828	829	830	831	832	833	834	835	836	837	838	839	840
841	842	843	844	845	846	847	848	849	850	851	852	853	854	855	856	857	858	859	860	861	862	863	864	865	866	867	868	869	870
871	872	873	874	875	876	877	878	879	880	881	882	883	884	885	886	887	888	889	890	891	892	893	894	895	896	897	898	899	900
901	902	903	904	905	906	907	908	909	910	911	912	913	914	915	916	917	918	919	920	921	922	923	924	925	926	927	928	929	930
931	932	933	934	935	936	937	938	939	940	941	942	943	944	945	946	947	948	949	950	951	952	953	954	955	956	957	958	959	960
961	962	963	964	965	966	967	968	969	970	971	972	973	974	975	976	977	978	979	980	981	982	983	984	985	986	987	988	989	990
991	992	993	994	995	996	997	998	999	1000	1001	1002	1003	1004	1005	1006	1007	1008	1009	1010	1011	1012	1013	1014	1015	1016	1017	1018	1019	1020
1021	1022	1023	1024	1025	1026	1027	1028	1029	1030	1031	1032	1033	1034	1035	1036	1037	1038	1039	1040	1041	1042	1043	1044	1045	1046	1047	1048	1049	1050
1051	1052	1053	1054	1055	1056	1057	1058	1059	1060	1061	1062	1063	1064	1065	1066	1067	1068	1069	1070	1071	1072	1073	1074	1075	1076	1077	1078	1079	1080
1081	1082	1083	1084	1085	1086	1087	1088	1089	1090	1091	1092	1093	1094	1095	1096	1097	1098	1099	1100	1101	1102	1103	1104	1105	1106	1107	1108	1109	1110
1111	1112	1113	1114	1115	1116	1117	1118	1119	1120	1121	1122	1123	1124	1125	1126	1127	1128	1129	1130	1131	1132	1133	1134	1135	1136	1137	1138	1139	1140
1141	1142	1143	1144	1145	1146	1147	1148	1149	1150	1151	1152	1153	1154	1155	1156	1157	1158	1159	1160	1161	1162	1163	1164	1165	1166	1167	1168	1169	1170
1171	1172	1173	1174	1175	1176	1177	1178	1179	1180	1181	1182	1183	1184	1185	1186	1187	1188	1189	1190	1191	1192	1193	1194	1195	1196	1197	1198	1199	1200

Computer-Related Businesses: FEBRUARY 492RSU

Please send me one year of BYTE Magazine for \$24.95 and bill me. Offer valid in U.S. and possessions only.



NO POSTAGE NECESSARY IF MAILED IN THE UNITED STATES

BUSINESS REPLY MAIL
FIRST CLASS MAIL PERMIT NO. 176 PITTSFIELD, MA

POSTAGE WILL BE PAID BY ADDRESSEE



READER SERVICE
PO Box 5110
Pittsfield, MA 01203-9926
USA



FREE INFORMATION

Want More Information About the Products and Advertisers Featured in this Issue?

1 Circle numbers on reply card which correspond to numbers assigned to items of interest to you.

2 Check all the appropriate answers to questions "A" through "C".

3 Print your name and address and mail.

NO POSTAGE
NECESSARY
IF MAILED
IN THE
UNITED STATES

BUSINESS REPLY MAIL

FIRST CLASS MAIL PERMIT NO. 176 PITTSFIELD, MA

POSTAGE WILL BE PAID BY ADDRESSEE

BYTE

READER SERVICE
PO Box 5110
Pittsfield, MA 01203-9926
USA



Fill out this coupon carefully. PLEASE PRINT.

Name _____

Title _____ (_____) Phone _____

Company _____

Address _____

City _____ State _____ Zip _____

A. What is your level of management responsibility?

- 1 Senior-level Management
- 2 Other Management
- 3 Non-Management

B. What is your primary job function/principal area of responsibility? (Check one.)

- 1 Administration
- 2 Accounting/Finance
- 3 MIS/DP/Information Center
- 4 Product Design and Development
- 5 Research and Development
- 6 Manufacturing
- 7 Sales/Marketing
- 8 Purchasing
- 9 Personnel
- 10 Education/Training
- 11 Other: _____

C. Please indicate your organization's primary business activity: (Check one.)

- 1 Manufacturer (Hardware, Software)

- 2 Computer Retail Stores
- 3 Consultants
- 4 Service Bureau/Planning
- 5 Distributor/Wholesaler
- 6 Systems House/ Integrator/VAR
- 7 Other: _____

Non-Computer-Related Businesses:

- 8 Manufacturing
- 9 Finance, Insurance, Real Estate
- 10 Retail/Wholesale
- 11 Education
- 12 Government
- 13 Military
- 14 Professions (Law, Medicine, Engineering, Architecture)
- 15 Consulting
- 16 Other Business Services
- 17 Transportation, Communications, Utilities
- 18 Other: _____

1	2	3	4	5	6	7	8	9	10	11	12	13	14	15	16	17	18	19	20	21	22	23	24	25	26	27	28	29	30
31	32	33	34	35	36	37	38	39	40	41	42	43	44	45	46	47	48	49	50	51	52	53	54	55	56	57	58	59	60
61	62	63	64	65	66	67	68	69	70	71	72	73	74	75	76	77	78	79	80	81	82	83	84	85	86	87	88	89	90
91	92	93	94	95	96	97	98	99	100	101	102	103	104	105	106	107	108	109	110	111	112	113	114	115	116	117	118	119	120
121	122	123	124	125	126	127	128	129	130	131	132	133	134	135	136	137	138	139	140	141	142	143	144	145	146	147	148	149	150
151	152	153	154	155	156	157	158	159	160	161	162	163	164	165	166	167	168	169	170	171	172	173	174	175	176	177	178	179	180
181	182	183	184	185	186	187	188	189	190	191	192	193	194	195	196	197	198	199	200	201	202	203	204	205	206	207	208	209	210
211	212	213	214	215	216	217	218	219	220	221	222	223	224	225	226	227	228	229	230	231	232	233	234	235	236	237	238	239	240
241	242	243	244	245	246	247	248	249	250	251	252	253	254	255	256	257	258	259	260	261	262	263	264	265	266	267	268	269	270
271	272	273	274	275	276	277	278	279	280	281	282	283	284	285	286	287	288	289	290	291	292	293	294	295	296	297	298	299	300
301	302	303	304	305	306	307	308	309	310	311	312	313	314	315	316	317	318	319	320	321	322	323	324	325	326	327	328	329	330
331	332	333	334	335	336	337	338	339	340	341	342	343	344	345	346	347	348	349	350	351	352	353	354	355	356	357	358	359	360
361	362	363	364	365	366	367	368	369	370	371	372	373	374	375	376	377	378	379	380	381	382	383	384	385	386	387	388	389	390
391	392	393	394	395	396	397	398	399	400	401	402	403	404	405	406	407	408	409	410	411	412	413	414	415	416	417	418	419	420
421	422	423	424	425	426	427	428	429	430	431	432	433	434	435	436	437	438	439	440	441	442	443	444	445	446	447	448	449	450
451	452	453	454	455	456	457	458	459	460	461	462	463	464	465	466	467	468	469	470	471	472	473	474	475	476	477	478	479	480
481	482	483	484	485	486	487	488	489	490	491	492	493	494	495	496	497	498	499	500	501	502	503	504	505	506	507	508	509	510
511	512	513	514	515	516	517	518	519	520	521	522	523	524	525	526	527	528	529	530	531	532	533	534	535	536	537	538	539	540
541	542	543	544	545	546	547	548	549	550	551	552	553	554	555	556	557	558	559	560	561	562	563	564	565	566	567	568	569	570
571	572	573	574	575	576	577	578	579	580	581	582	583	584	585	586	587	588	589	590	591	592	593	594	595	596	597	598	599	600
601	602	603	604	605	606	607	608	609	610	611	612	613	614	615	616	617	618	619	620	621	622	623	624	625	626	627	628	629	630
631	632	633	634	635	636	637	638	639	640	641	642	643	644	645	646	647	648	649	650	651	652	653	654	655	656	657	658	659	660
661	662	663	664	665	666	667	668	669	670	671	672	673	674	675	676	677	678	679	680	681	682	683	684	685	686	687	688	689	690
691	692	693	694	695	696	697	698	699	700	701	702	703	704	705	706	707	708	709	710	711	712	713	714	715	716	717	718	719	720
721	722	723	724	725	726	727	728	729	730	731	732	733	734	735	736	737	738	739	740	741	742	743	744	745	746	747	748	749	750
751	752	753	754	755	756	757	758	759	760	761	762	763	764	765	766	767	768	769	770	771	772	773	774	775	776	777	778	779	780
781	782	783	784	785	786	787	788	789	790	791	792	793	794	795	796	797	798	799	800	801	802	803	804	805	806	807	808	809	810
811	812	813	814	815	816	817	818	819	820	821	822	823	824	825	826	827	828	829	830	831	832	833	834	835	836	837	838	839	840
841	842	843	844	845	846	847	848	849	850	851	852	853	854	855	856	857	858	859	860	861	862	863	864	865	866	867	868	869	870
871	872	873	874	875	876	877	878	879	880	881	882	883	884	885	886	887	888	889	890	891	892	893	894	895	896	897	898	899	900
901	902	903	904	905	906	907	908	909	910	911	912	913	914	915	916	917	918	919	920	921	922	923	924	925	926	927	928	929	930
931	932	933	934	935	936	937	938	939	940	941	942	943	944	945	946	947	948	949	950	951	952	953	954	955	956	957	958	959	960
961	962	963	964	965	966	967	968	969	970	971	972	973	974	975	976	977	978	979	980	981	982	983	984	985	986	987	988	989	990
991	992	993	994	995	996	997	998	999	1000	1001	1002	1003	1004	1005	1006	1007	1008	1009	1010	1011	1012	1013	1014	1015	1016	1017	1018	1019	1020
1021	1022	1023	1024	1025	1026	1027	1028	1029	1030	1031	1032	1033	1034	1035	1036	1037	1038	1039	1040	1041	1042	1043	1044	1045	1046	1047	1048	1049	1050
1051	1052	1053	1054	1055	1056	1057	1058	1059	1060	1061	1062	1063	1064	1065	1066	1067	1068	1069	1070	1071	1072	1073	1074	1075	1076	1077	1078	1079	1080
1081	1082	1083	1084	1085	1086	1087	1088	1089	1090	1091	1092	1093	1094	1095	1096	1097	1098	1099	1100	1101	1102	1103	1104	1105	1106	1107	1108	1109	1110
1111	1112	1113	1114	1115	1116	1117	1118	1119	1120	1121	1122	1123	1124	1125	1126	1127	1128	1129	1130	1131	1132	1133	1134	1135	1136	1137	1138	1139	1140
1141	1142	1143	1144	1145	1146	1147	1148	1149	1150	1151	1152	1153	1154	1155	1156	1157	1158	1159	1160	1161	1162	1163	1164	1165	1166	1167	1168	1169	1170
1171	1172	1173	1174	1175	1176	1177	1178	1179	1180	1181	1182	1183	1184	1185	1186	1187	1188	1189	1190	1191	1192	1193	1194	1195	1196	1197	1198	1199	1200

Please send me one year of BYTE Magazine for \$24.95 and bill me. Offer valid in U.S. and possessions only.

FEBRUARY
492RSU

THIS IS NO PLACE FOR SPACE INVADERS.



A business desk is no place to play games with space. So NEC built three serious machines with one mission in mind: optimum performance in a minimum space. Meet PowerMate® 1, PowerMate 1 Plus and PowerMate SX.

The PowerMate 1 and PowerMate 1 Plus get right down to business. They're industry standard. Powerful. Affordable. Both PCs race through spreadsheets, graphics and hundreds of other general office applications. And with six option slots and memory

expandable to over 10MB, they're ready for the inevitable result of all that tough work. Growth.

The PowerMate SX is for those who want more power. And want it now. Here's 386 power without the 386 price. Which means it can run the most advanced software applications in the world, including Windows™/386, as well as any 286-based applications.

All three machines are part of a complete family of top quality PCs, each compatible with popular networks and industry standard hardware peripherals. All proudly backed by NEC, the \$22 billion leader in computers and communications.

If you're ready to do more business in less space, call 1-800-NEC-INFO (in Canada, 1-800-343-4418). Today.

NEC



PowerMate 1
Intel® 286 microprocessor
10/8 MHz

PowerMate SX
Intel 386SX™ microprocessor
16/8 MHz

PowerMate 1 Plus
Intel 286 microprocessor
12/8 MHz

Tandy Computers: The broadest line of PCs in America.



The Tandy® 4000 LX

To streamline your heavy business tasks, turn to the Tandy 4000 LX. With its 32-bit Intel® 80386 microprocessor operating at 20 MHz, the 4000 LX delivers a new level of performance to sophisticated database management and spreadsheet analysis applications.

Two megabytes of zero wait-state memory make the 4000 LX ready to use with MS® OS/2, as well as MS-DOS® software. With this much memory standard, the Tandy 4000 LX is also ready to use as the

hub of a powerful multiuser office system running SCO™ XENIX® software. And as a network file server in a 3Com® workgroup, the 4000 LX provides 20 MHz performance for exceptionally high-speed data transfer.

The Tandy 4000 LX is highly expandable. Three front-panel device slots and eight expansion slots give power users the flexibility needed in configuring the optimum system. VGA graphics for desktop publishing, an Intel 80387 math

Get the power
and performance
of Intel's 80386
...at 20 MHz.

coprocessor for math-intensive applications and SCSI technology for high-performance disk storage are but a few of the many expansion options available.

And for entry-level 386™ power, we offer the original Tandy 4000. Using an 80386 processor that operates at 16 MHz, the 1MB Tandy 4000 is the perfect low-cost choice for the heavy power user.

The new generation Tandy 4000 LX. From the best-selling family of PC compatibles made in America.

Tandy Computers: Because there is no better value™

Intel/Reg. TM and 386/TM Intel Corp. MS, MS-DOS and XENIX/Reg. TM Microsoft Corp.
SCO/TM The Santa Cruz Operation. 3Com/Reg. TM 3Com Corp.

Radio Shack®
COMPUTER CENTERS

A DIVISION OF TANDY CORPORATION

Circle 193 on Reader Service Card